

## Advanced Modelling and Control of 5 MW Wind Turbine using Global Optimization

### Algorithms

Soheil Jafari<sup>1</sup>, Mohsen Majidi Pishkenari<sup>2</sup>, Shahin Sohrabi<sup>3</sup>, Morteza Feizarefi<sup>4</sup>

#### Abstract

This paper presents a methodological approach for controller gain tuning of wind turbines using global optimization algorithms. For this purpose, the wind turbine structural and aerodynamic modelling are firstly described and a complete model for a 5 MW wind turbine is developed as a case study based on a systematic modelling approach. The turbine control requirements are then described and classified using its power curve to generate an appropriate control structure for satisfying all turbine control modes simultaneously. Next, the controller gain tuning procedure is formulated as an engineering optimization problem where the command tracking error as well as minimum response time are defined as objective function indices and physical limitations (over-speed and oscillatory response) are considered as penalty functions. Taking the nonlinear nature of the turbine model and its controller into account, two meta-heuristic global optimization algorithms (Imperialist Competitive Algorithm and Differential Evolution) are used to deal with the defined objective functions where the mechanism of interaction between the defined problem and the used algorithms are presented in a flowchart feature. The results confirm that the proposed approach is satisfactory and both algorithms are able to achieve the optimized controller for the wind turbine.

**Keywords:** wind turbine, controller gain tuning, optimization, meta-heuristics, imperialist competitive algorithm, differential evolution.

---

<sup>1</sup> School of Aerospace, Transport and Manufacturing (SATM), Cranfield University, United Kingdom

<sup>2</sup> Department of Aerospace Engineering, Sharif university of technology, Tehran, Iran

<sup>3</sup> Department of Aerospace Engineering, Sharif university of technology, Tehran, Iran

<sup>4</sup> Department of Aerospace Engineering, Sharif university of technology, Tehran, Iran

**E-mail:** [S.Jafari@sussex.ac.uk](mailto:S.Jafari@sussex.ac.uk)

## Nomenclature

$a$ Axial induction factor	L lift	$\beta$ Pitch angle
$a'$ Tangential induction factor	M Torque, aerodynamic moment	$\gamma$ Weighting factor
b Pitch angle	N Number of blades	$\lambda$ Tip speed ratio
$c(r)$ Local chord of the control volume	r Rotor speed,	$\rho$ Air density
$C_D$ Drag coefficient	$r^*$ Desired rotor speed	$\sigma$ Solidity
$C_L$ Lift coefficient	$P_i$ Penalty functions	$\Phi$ Flow angle
$C_m$ Moment coefficient	R Blade radius	$\tau$ Commanded torque
$C_n$ Normal force coefficient	Sim-Time Simulation time	$\varepsilon$ Augmentation factor
$C_{Pmax}$ Maximum power coefficient	V velocity	$\Omega$ Impeller rotational speed
J Objective function	$V_o$ Wind speed	$\omega$ Angular velocity of rotor
K Controller gain	$V_{in}$ Induced velocity	$\Delta$ Penalty factor
	$\alpha$ Angle of attack	

## 1. Introduction

Energy extraction has been always a challenging issue in industrial consumptions. Due to problems such as pollution, lack of resources, mining problems, high fuel costs, and to name but a few, use of renewable energy has played an important role in recent decade. Among different kinds of renewable energy resource, wind energy is an attractive field [1]. Wind turbines with rudimentary control systems that aim to minimize cost and maintenance of the installation have predominated for a long time [2]. More recently, the increasing size of the turbines and the greater penetration of wind energy into the utility networks of leading countries have encouraged the use of electronic converters and mechanical actuators [3]. Consequently, in order to decrease wind energy cost it seems that design and implementation of optimized control systems plays an important role. An appropriate control strategy can improve energy capture and reduce dynamic loads in wind turbines [4].

In order to design a successful controller, a reliable precise model of the wind turbine is required at the first step. There are several studies on modelling of a wind turbine. Some of them are based on aerodynamic approaches in which the kinetic energy obtained by the blades is transformed into mechanical torque [5-8]. Other studies use simplified mechanical model of the power train to predict the wind turbine behavior [9-11]. In this paper, a combination of both aerodynamic and structural modelling approaches is used for developing an algorithmic

procedure to achieve a detailed precise model for a wind turbine. This approach is used in detail by Resor for a 5MW/61.5m wind turbine blade to create a blade model via NuMAD<sup>5</sup> as well as to analyze the blade structural performance [12].

In addition, there are many studies on wind turbine aerodynamic and speed control in order to satisfy the turbine control modes. These control objectives usually are: capturing the wind power as possible as it can [13], maximizing the wind harvested power in partial load [14], meeting strict power quality standards [15], achieving the desired rotor speed [16], and preventing the turbine from physical limitations [17, 18]. To achieve the above mentioned objectives both classical control strategies (PI, PID, Cascade control) [19-22] and advanced control strategies (predictive control, Fuzzy control, Sliding mode, etc.) [23-26] are proposed by the researchers successfully.

However, taking the complicated and nonlinear nature of the real-world engineering systems into account, all of the above mentioned control algorithms suffer from a good gain tuning procedure in order to catch the optimized wind turbine performance [27]. Recently, the use of Global Optimization (GO) algorithms for dealing with real-world engineering optimization problems is widely considered. Several huge projects focusing on the use of GO methods in well-known industrial applications like aerospace engineering [28], propulsion systems [29], and etc. [30-31] are funded in recent years as well. In this paper, application of global optimization algorithms for gain tuning of the wind turbine controllers is proposed as a methodological approach for the first time (to the best knowledge of the authors). The tuning process can be defined as an engineering optimization problem which should be solved using a model independent approach because the analytical optimization algorithms may trapped in local optimum. The Imperialist Competitive Algorithm (ICA) as a newly established global optimization algorithm [32] and the Differential Evolution (DE) [33] are used in order to cope with the controller design of wind turbines. These algorithms are widely used in system structure design [34], controller structure design [35], controller gain tuning and performance optimization [36], advanced controller [37] and technology design [38], and in many other applications and their ability to deal with non-linear real-world complex problems with huge number of parameters are confirmed.

For this purpose, wind turbine advanced modelling is described in section two explaining different parts of the wind turbine (structural and aerodynamic). These sub-models are combined and the wind turbine model is generated. Controller design procedure including classical control strategy and modern control approaches is then explained in section three. An industrial control strategy is also developed for the designed model. A computer simulation program is also created in MATLAB/Simulink environment to predict the dynamic behavior of the turbine and controller.

---

<sup>5</sup> Numerical Manufacturing And Design Tool

Next, the used meta-heuristic algorithms are described in section four. This section includes objective function formulation with complete details of the indices and the penalty functions, the used optimization algorithms (Imperialist Competitive Algorithm (ICA), and Differential Evolution (DE)) and the mechanism of its interaction with the defined objective function. In section five optimization results and effect of optimization on the wind turbine performance is presented in order to confirm the effectiveness of the proposed approach. Finally, the conclusion remarks are presented in chapter six.

## 2. Wind Turbine Modeling

In order to model a wind turbine, different kinds of knowledge is required. Two general parts are considered in modeling of wind turbine: structural dynamics and aerodynamics. Without loss of generality, a horizontal axis wind turbine with three blades and 5 MW capacities is selected as the case study in this paper, where information of this case is provided by the National Renewable Energy Laboratory (NREL) institute. General characteristics of the wind turbine blades have been shown in table1:

Table 1: structural characteristics of 5MW wind turbine blades [39-40]

<b>Length of Blade</b>	61.5 m
<b>Total mass of blade</b>	17740 kg
<b>Second moment inertia</b>	11776047 <i>kg.m<sup>2</sup></i>
<b>First moment of inertia</b>	363231 <i>kg.m</i>
<b>Position of center of gravity from blade's root</b>	20475 m
<b>Structure's damping ratio for all state</b>	0.477465 %

Schematic diagram of a wind turbine model is shown in Fig.1. As shown in this figure, for start-up the wind turbine, aerodynamics and dynamics should be coupled. So, both substructures are described respectively in the next sections.

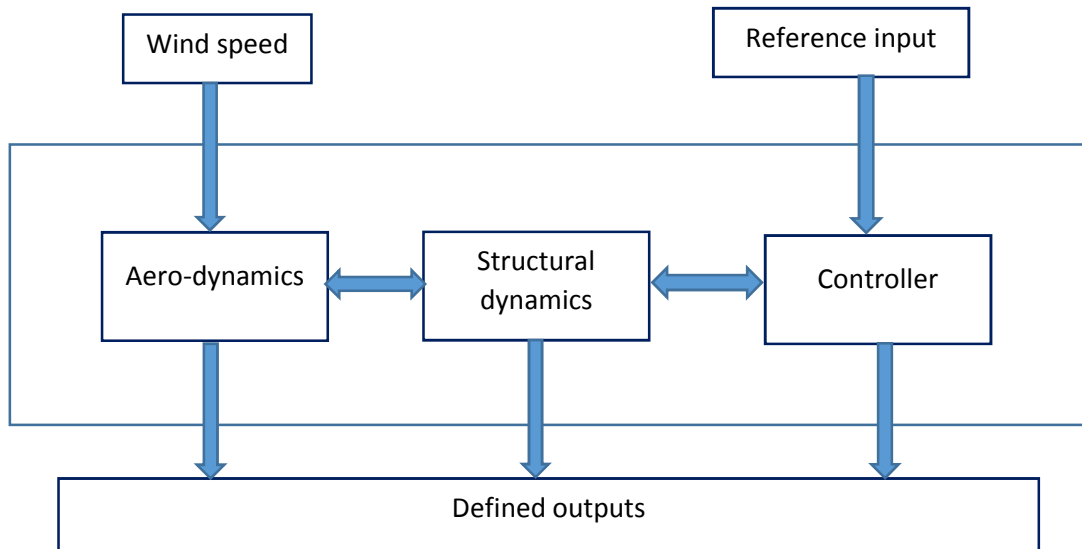

Fig.1: Conceptual design of wind turbine [40]

## 2.1 Structural dynamics of wind turbine

Structural dynamics constituents are tower, nacelle, and blades. The modeling of each part is described in this section.

- **Tower Modeling:** The tower has been modeled like a rigid beam which connected to the ground. So there are not any movement in connection point to the nacelle.
- **Nacelle Modeling:** Nacelle is composed from generator set and the drivetrain. In this set, rotor hub speed is transmit to low speed shaft. This speed is transmitted by the gearbox to the high speed shaft and generator to produce electricity. Thus, the generator torque control is one of the purposes of this paper.
- **Blades Modeling:** The blade model includes of several linear systems. The blades are divided into 17 sections and the information of each sections are available in [39]. The geometrical and structural properties (bending stiffness, torsion stiffness, damping, density, geometrical pitch angle) are constant in each element and would be a function of their distance from the root. These systems involved the rigid beam shape elements which connected to each other by special connections (Fig.2).



Fig 2: Modeling of structural rigid beam,(a) For entire model,(b)For each elements [40]

## 2.2 Aerodynamic model

The aerodynamics blade shapes significantly play an important role in generating power and the efficiency of system. Modern wind turbines have complex aerodynamic blades shape with different properties for each point of blades. The blades of the in-hand wind turbine have 3 different types of airfoils that thickness, geometrical pitch angle, and taper ratio changed by distance from blade root. The sections that are near to the roots is modeled as a cylinder. These sections do not have any lift coefficient and Drag. The other ones are modeled with 6 different airfoils. Geometrical characteristics of all 17 sections are given in Table 2.

Table 2: Aerodynamics properties

<b>Node</b>	<b>RNodes</b>	<b>AeroTwst</b>	<b>DRNodes</b>	<b>Chord</b>	<b>Airfoil Type</b>
<b>(-)</b>	<b>(m)</b>	<b>(°)</b>	<b>(m)</b>	<b>(m)</b>	<b>(-)</b>
1	2.8667	13.308	2.7333	3.542	Cylinder1
2	5.6000	13.308	2.7333	3.854	Cylinder1
3	8.3333	13.308	2.7333	4.167	Cylinder2
4	11.7500	13.308	4.1000	4.557	DU40_A17
5	15.8500	11.480	4.1000	4.652	DU35_A17
6	19.9500	10.162	4.1000	4.458	DU35_A17
7	24.0500	9.011	4.1000	4.249	DU30_A17
8	28.1500	7.795	4.1000	4.007	DU25_A17
9	32.2500	6.544	4.1000	3.748	DU25_A17
10	36.3500	5.361	4.1000	3.502	DU21_A17

11	40.4500	4.188	4.1000	3.256	DU21_A17
12	44.5500	3.125	4.1000	3.010	NACA64_A17
13	48.6500	2.319	4.1000	2.764	NACA64_A17
14	52.7500	1.526	4.1000	2.518	NACA64_A17
15	56.1667	0.863	2.7333	2.313	NACA64_A17
16	58.9000	0.370	2.7333	2.086	NACA64_A17
17	61.6333	0.106	2.7333	1.419	NACA64_A17

Where:

- RNodes is distance between the elements center to root.
- AeroTwst is aerodynamics twist angle.
- DRNodes is distance of adjacent elements center.
- Type of airfoil for each element is shown in last column.

Using information of Tables 1 and 2 an in-house MATLAB code is developed to generate the distribution of  $C_L$  and  $C_D$  for each section based on extrapolation. Extrapolated functions are shown in Fig.3. These values are validated with [39].

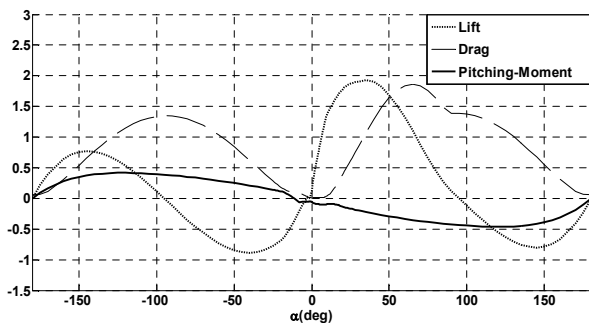

a) Corrected Coefficients of the Du40-A17 airfoil

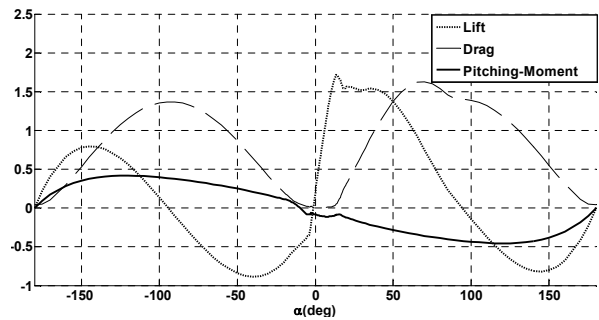

b) Corrected Coefficients of the Du35-A17 airfoil

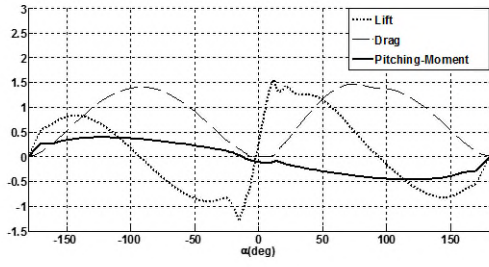

c) Corrected Coefficients of Du30-A17 airfoil

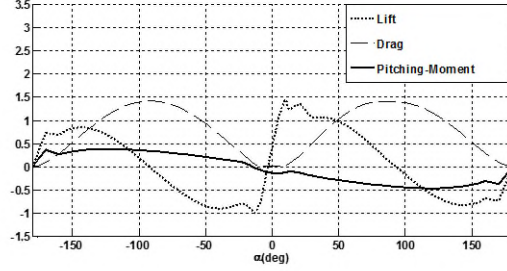

d) Corrected Coefficients of the Du25-A17 airfoil

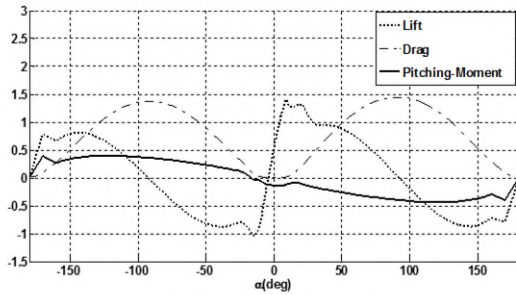

e) Corrected Coefficients of the Du21-A17 airfoil

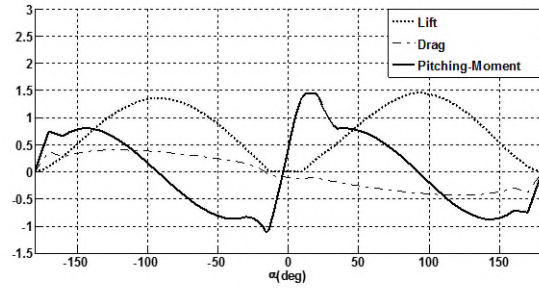

f) Corrected Coefficients of the NACA-64 airfoil

Fig.3: Distribution of  $C_l$ ,  $C_d$  and  $C_m$  for each airfoils

The blade element momentum (BEM) theory is used for aerodynamic modeling. Based on this theory, lift and drag coefficients of the blade sections are determined by the angle of attack by combination of the momentum conservation law and the Glauert blade element theory in which the airfoil's angle of attack ( $\alpha$ ) is obtained by considering the effect of wind speed ( $V$ ), the induced velocity ( $V_{in} = aV$ ), impeller rotational speed ( $\Omega$ ), and the initial torsion angle ( $\beta$ ). Different steps of the blade element momentum theory follow by figure 4 flowchart.

To generate the model using this algorithm, The initial value of  $a$  and  $a'$  considered arbitrary for starting the moment calculation's loop and this will be continue while the difference between  $a$  and  $a'$  converge to specific value. Each section of the blade have a unique pitch angle and geometry, moments of rotor, and aerodynamic characteristics. . Finally the total moment obtained by summation of each element's moment. As it shown in the figure 4, to calculate the local loads on the segment of the blades, aerodynamic variables such as  $C_L$ ,  $C_D$ ,  $C_n$  and  $C_t$  are required. The aerodynamic and structural equations should be used simultaneously to generate these variables. As mentioned on structural considerations, it is assumed that the system involved the rigid beam shape elements. Also the overall blade mass of the reference turbine blade was matched based on [12].



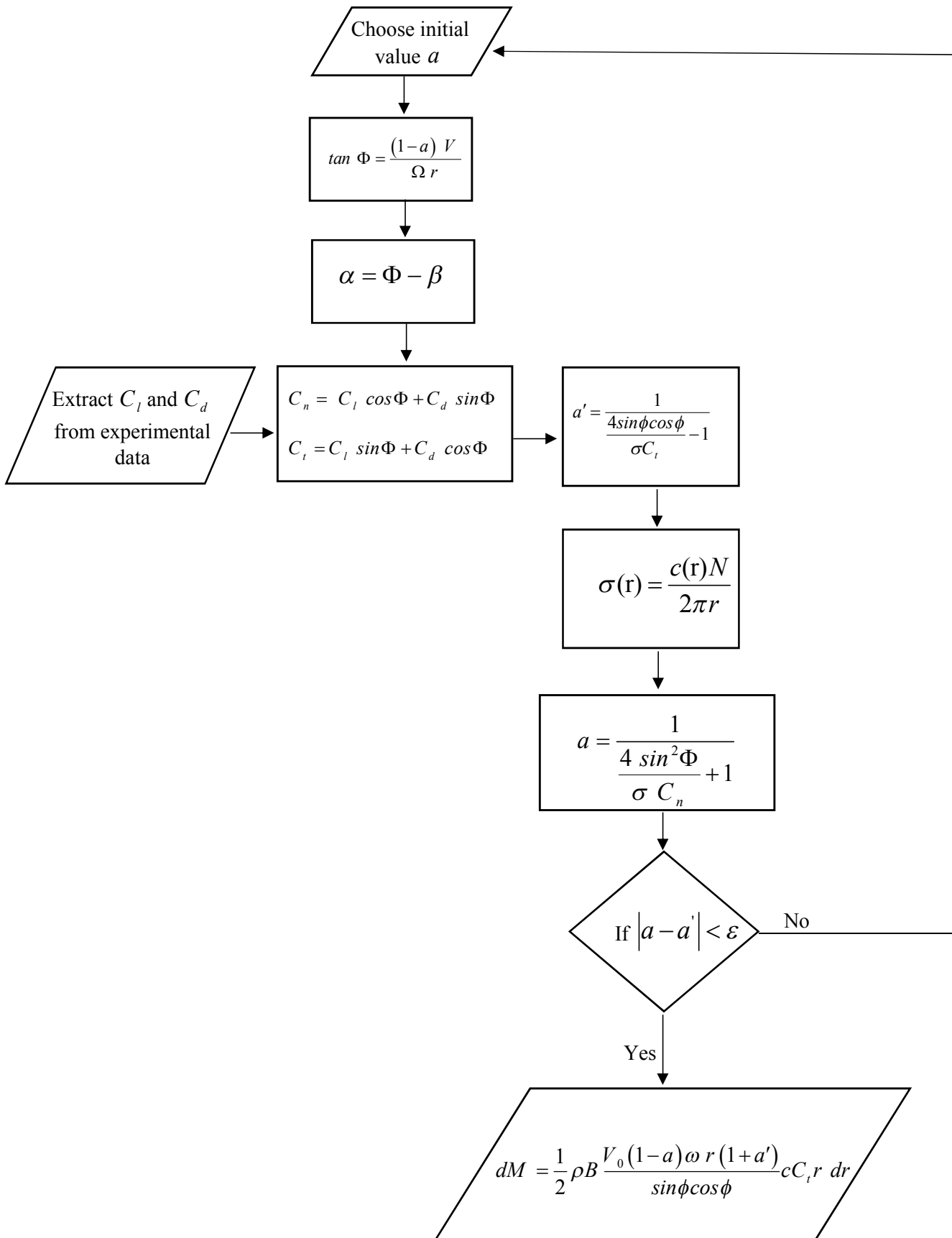

Fig.4: Aerodynamics model's flowchart

### 3. Wind Turbine Control

The wind turbine control structure design (CSD) is explained in this section based on the turbine power curve and different operating regions.

#### 3.1. Wind Turbine Power Curve

In order to identify the wind turbine control modes, the operating condition of the turbine is divided into three distinct regions:

- I) **Region I.** if the wind speed is less than cut-in speed, typically between 3 and 4 m/s, the turbine doesn't start rotating and generating power
- II) **Region II.** If the wind speed is between the cut-in speed and the rated speed, blade pitch angle remain in a constant value and generator torque is controlled in order to reach the maximum value of energy. This region in that the wind speed is variable known as region II (Fig.5). The torque of generator change linearly in a part of this region (region II/2).
- III) **Region III,** wind speed is more than rated speed in this region; so the generator's torque should be constant and blade-pitch control maintains rated power and rotor speed by shedding excess aerodynamic power. This region has been show in Fig.5. Demanded torque  $\tau$  in regions II and III is calculated as follow [16] :

$$\tau(\omega) = \begin{cases} 0 & \text{Region I} \\ \tau_1 + \frac{k\omega^2}{\omega_{rated} - \omega_1} (\omega - \omega_1) & \text{Region II} \\ \tau_{rated} & \text{Region III} \end{cases} \quad (1)$$

Where  $\omega$  is generator's speed and

$$k = \frac{1}{2} r \rho R^5 \frac{C_{p,max}}{l^3} \quad (2)$$

Where  $C_{p,max}$  is the maximum power coefficient,  $r$  is the air density,  $R$  is the blade radius and  $l$  is the optimum rated speed of wing tips (TSR).

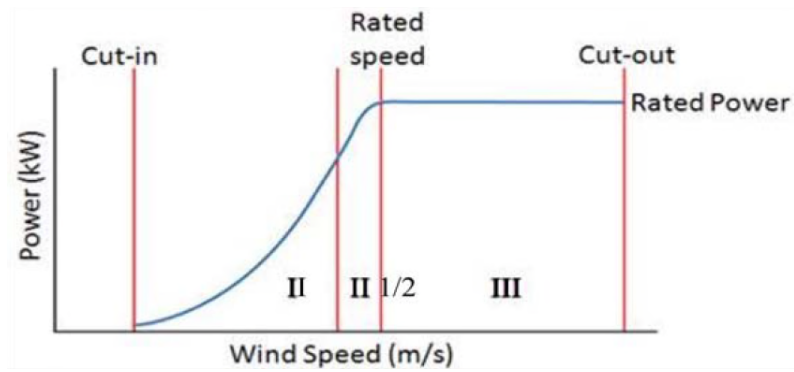

Fig.5: Regions of operation of wind turbine [39]

### 3.2 Controller design and structure

The main objective of wind turbine control is to satisfy all of its control modes simultaneously. An optimized controller would effectively deal with the turbine control modes with simplest and most accurate possible feature in a reasonable response time. In general, wind turbine control modes could be summarized as follow:

- Reduce the dynamic loads on the rotor shaft, the blade root and powertrain systems
- Control of the generated electrical power based on wide range of wind speeds to try to control the electrical power in a steady value.
- Controlling unwanted loads.

All of the above mentioned control modes (except unwanted load attenuation) are functions of the turbine rotational speed. So, the aim of this study is to design a controller so that we can reach an optimum speed rotor. In order to achieve the desired rotor speed, collective pitch angle should be controlled. Change in pitch angles causes to achieve torque proportional to desired rotor speed by changing the lift and drag coefficient. The control structure would then be like figure 6.

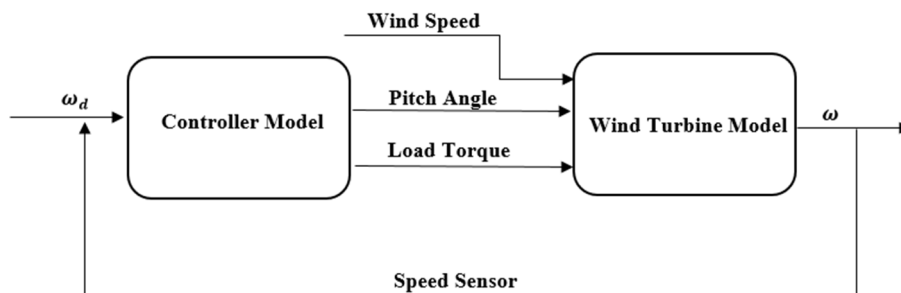

Figure.6: Wind turbine controller structure

Control law design and tuning is one of the most challenging parts of the wind turbine design and implementation procedure. Effective control strategy and control law should be set up in order to satisfy all of wind turbine control modes in minimum time response and with maximum energy absorption. Generally, both classical and modern control strategies are used in the literature:

### **3.2.1 Classical control strategies:**

In classic design, the control strategy of a wind turbine consists of two control loops in general: blade pitch control loop and torque control loop. The former is often programmed by a simple proportional-integral (PI) based collective blade pitch controller, which receives its input signal from the error in generator speed. Individual pitch control for reducing loads on the wind turbine structure has also been investigated in [16,17], even though this solution requires careful gain tuning procedure. In order to avoid pitch controllers from interfering with the torque control system of the plant, the torque control is usually a gain scheduling loop.

Consequently, one SISO controller is design for the pitch control of the wind turbine and another SISO controller is designed for torque control accomplishment. After that, these controllers are combined with each other to complete the control strategy of the wind turbine. It is worthwhile to mention that because of the cascade nature of this type of control strategy, the controller gains of all loops should be tuned simultaneously in an optimized manner to achieve the best possible performance for the turbine. Moreover, the controller gains should be changed in different regions of the turbine working conditions. More details about the control strategy and industrial cascade control design could be found in [41-46].

### **3.2.2 Modern control approaches:**

Modern control approaches like robust control and optimal control are also used for wind turbines recently [23-26, 47, 48]. The main advantage of these approaches is its high performance and accuracy. In other words, control and performance optimization of wind turbine are easier in modern approach than the classical strategy. But, on the other hand, implementation and debugging of controllers implemented with these approaches are more expensive and complicated. However, the gain tuning procedure is also a major problem in these algorithms that should be addressed successfully to achieve the optimized performance of the turbine.

### **3.2.3 Control Structure Design:**

As mentioned above, both classical and modern control strategy of wind turbine, are facing with the issue of gain tuning problem. This issue would be addressed here using global optimization algorithms for the first time. For

this purpose, the procedure of controller gain tuning for a wind turbine is formulated as an engineering optimization problem which should be solved by meta-heuristic optimization algorithms respect to the nonlinear behavior of the wind turbine and control structure. Without loss of generality, a classical control structure is used as a case study.

For this purpose, a PID controller for a pitch control and a gain scheduling controller for torque control of the wind turbine is designed. The generated MATLAB/Simulink turbine blade model and the designed controller is shown in figure 7.

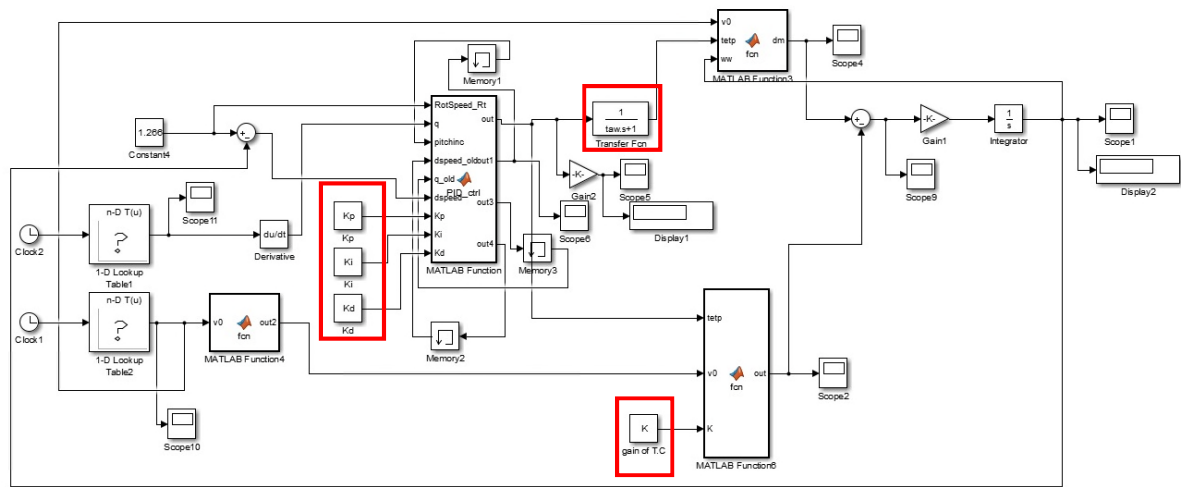

Fig.7: Wind turbine model and controller simulation

A PID controller with a specific strategy has been used in this study to control blades pitch angle in which the difference of blades pitch angle with the latest step can be calculated by following equations:

$$Db_k = [ Db_{k-1} + k_i \Delta r_k + k_d (\Delta r_k - \Delta r_{k-1}) ] \quad (3)$$

$$b_k = \max[1.4, b_{k-1} + Db_k + k_p \Delta r_k] \quad (4)$$

Where  $\Delta r_k$  is the error of speed in comparison with the desired speed:

$$\Delta r_k = r_k^* - r_k \quad (5)$$

The subscript  $k$  denoted the discrete time step,  $r$  is the filtered rotor speed,  $r^*$  is the desired rotor speed,  $\Delta r_k$  is error between the actual and desired rotor speed,  $Db$  is the change in pitch from each time period to the next,  $b$  is the pitch angle, and  $k_p, k_i, k_d$  are the proportional, integral, and derivative gains, respectively. The (max) function allows the controller to run throughout all three operating regions

(described in section 3.1) by saturating the pitch angle to a value of  $1.4^{\circ}$ . The generator torque is also regulated by a gain scheduling controller using equations 1 and 2. As shown in Fig.7 the output of the pitch controller output should be crossed from a low-pass filter in order to avoid fluctuations in the control output. Consequently, there are 5 control variables should be tuned in this problem:

- $K_p$ : Proportional Gain of the Pitch Controller
- $K_i$ : Integral Gain of the Pitch Controller
- $K_d$ : Derivative Gain of the Pitch Controller
- $K$ : Gain of the Torque Controller
- $T_{aw}$  : Lag of the Pitch Controller Filter

So, we are facing with a 5-D engineering optimization problem. It is clear that using analytical algorithms for this problem is not affordable (note that the dimension of the problem and so the complexity would be increased by using more industrial/modern control approaches). This controller gain tuning problem will be formulated and solved in the next sections.

#### **4 Application of meta-heuristic global optimization algorithms in wind turbine controller gain tuning**

In this section, application of two different meta-heuristic algorithms for optimization of the previously described controllers is explained. For this purpose, the controller gain tuning procedure is firstly formulated as an engineering optimization problem. An overview of the used methods is then presented and the interaction mechanism between the algorithms and the objective function is described in a flowchart feature. The optimization methods are applied to the problem and the results are analyzed as well.

##### **4.1 Objective Function Formulation**

As mentioned earlier, there are 5 different parameters to tune in the designed controller ( $K_p$ ,  $K_i$ ,  $K_d$ ,  $K$ ,  $T_{aw}$ ). In other words, the objective of the wind turbine controller is to drive the 6-D optimization problems (5 parameters and time) in order to achieve the best output of the fitness function. The fitness function in this paper is formulated based on:

- Minimizing the rise time of the turbine in region II
- Minimizing the tracking error for the desired rotational speed

The response also should change safe (without any overshoot and over speed) and smooth (without fluctuation) and in order to protect the turbine from malfunction and structural issues. These terms are defined as penalty functions for the objective. Therefore, the objective function is formulated as follows:

$$J = \frac{1}{\sum_{i=1}^2 \gamma_i} \left\{ \gamma_1 \int_0^{Sim-Time} (\omega_{des-N} - \omega_N) dt + \gamma_2 \frac{(T|\omega = 0.95\omega_{des})}{Sim-Time} \right\} + \sum \Delta_i P_i \quad (6)$$

Where:

*Sim-Time*      *Simulation time,*

$\omega$               *Rotational speed,*

$\omega_N$             *Normalized rotational speed,  $\omega_N = \omega / \omega_{max}$*

$\omega_{des}$          *Desired rotational speed,*

$\omega_{des-N}$       *Normalized desired rotational speed,  $\omega_{des-N} = \omega_{des} / \omega_{max}$*

$(T|\omega = 0.95\omega_{des})$     *The time in which the turbine rotational speed will reach the 95% of the desired value for the first time*

$\gamma_i$              *Dimensionless Weighting coefficients,*

$\Delta_i$             *Dimensionless Penalty factors,*

$P_i$             *Penalty functions.*

In equation (6), the performance indices are normalized first using the maximum value for each index (the maximum rotational speed and the total simulation time) and then weighted according to their importance by the dimensionless coefficients of  $\gamma_i$  between 0 and 1. The first term guarantees the rotor speed tracking with minimum possible error. The second indices minimizes the rise time and guarantees the fast response of the turbine.

The penalty functions are also the turbine overspeed (over-shoot or under-shoot more than 5%) as well as smooth response in order to satisfy the physical limitations control mode. So, the penalty function has two indices as well:

$$\sum \Delta_i P_i = (\Delta_1 |P_1| + \Delta_2 P_2) \quad (7)$$

The first indices is to limit the turbine over-shoot/under-shoot to protect the system from physical damages. The  $P_1$  is the maximum over-shoot (percentage) of the rotational speed during the simulation. In order to ensure that this penalty definition doesn't eliminate potential solutions, a graduated scale of penalty factor ( $\Delta_1$ ) proportional to the magnitude of the constraint violation is used as shown in Fig 8.

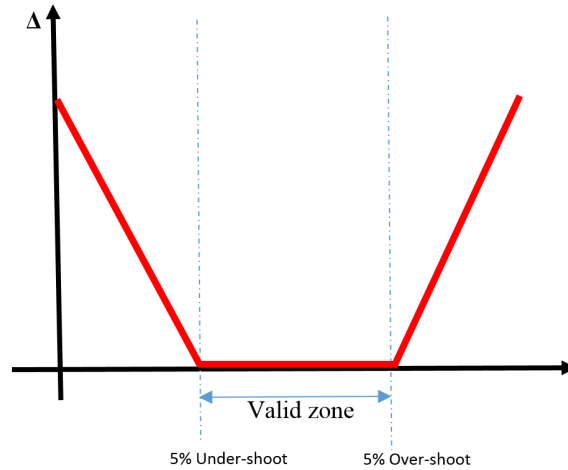

Fig. 8: Variable penalty factors for turbine speed violation

The second index in the penalty function formula is to confirm the smooth change in the controller output in order to protect the turbine from malfunction. In order to define this index, the solutions with fluctuation in controller output are penalized as follow:

$$\left\{ \begin{array}{l} \text{if } \text{sgn}(t_{k-2} - t_{k-3}) = \text{sgn}(t_k - t_{k-1}), \text{sgn}(t_{k-2} - t_{k-3}) \neq \text{sgn}(t_{k-1} - t_{k-2}) , \Delta_2 P_2 = 5 \\ \text{otherwise } \Delta_2 P_2 = 0 \end{array} \right. \quad (8)$$

The value of 5 is tuned manually to guarantee the omitting of the oscillatory solutions.

It is also worth mentioning that the suggested method could be used for other performance indices with different penalty functions in all turbine working regions. In addition, the design optimization variables are the controllers loop gains including,  $K_p$ ,  $K_i$ ,  $K_d$ ,  $K$ ,  $T_{aw}$  as shown in Fig.7. In other words, these 5 variables are going to be tuned using ICA and DE in order to minimize the objective function of equation (6).

#### 4.2 Optimization Problem Formulation

In this paper, the Imperialist Competitive Algorithm (ICA) as a relatively new-established evolutionary algorithm and the Differential Evolution (DE) as a well-established optimization method are used for the problem solution



for the first time. The next chapters describe the methodology of these algorithms and its interaction with the defined objective function briefly.

#### 4.2.1 Differential Evolution (DE)

Differential Evolution, completely related to Genetic Algorithm (GA), is a direct search global optimization algorithm. It also has some common concepts with Particle Swarm Optimization (PSO) [49]. The main idea of the DE is to start with a population of candidate solutions (with the number of NP). These agents are then moved around in the search-space by using algorithm operators (mutation (with the mutation factor of F), recombination (crossover with the probability of CR), and selection (using a simple one-to-one survivor selection method)) to find improved position. The process is repeated until the stopping criterion is met. So, the DE's control parameters should be selected precisely in order to get promising results. Fortunately, there are several rules in this regard were advised by Storn et al.[50, 51] and Liu and Lampinen [52]:

- $NP = 10 \times D$  is suggested for many applications where D is the problem dimension
- The suggestion for CR is to start with a value considerably lower than one (e.g. 0.3) and if no convergence can be achieved, then  $CR \in [0.8, 1]$  often helps.
- Many applications show that the  $CR \in [0.5, 1]$  would be a good choice.

Based on the above mentioned rules, the DE's control parameters are selected as follow for the in-hand problem:

- 1-  $NP=10 \times 5$  (respect to figure 7) = 50
- 2- CR: the optimization did not converge for lower values (e.g. 0.2, 0.3, 0.4, 0.5). So, based on the above mentioned rule, the values in the range of [0.8, 1] were tested. The best results was achieved for  $CR=0.88$  (with  $NP=50$  and constant  $F=0.5$ )
- 3- Finally, the optimization was run several times with different F values with respect to third rule (e.g. 0.5, 0.6, 0.7, 0.8, 0.4, 0.45, 0.47) and the best results were achieved for  $F=0.47$

The flowchart of the interaction of the differential evolution algorithm and the wind turbine controllers' gains tuning problem is presented below:

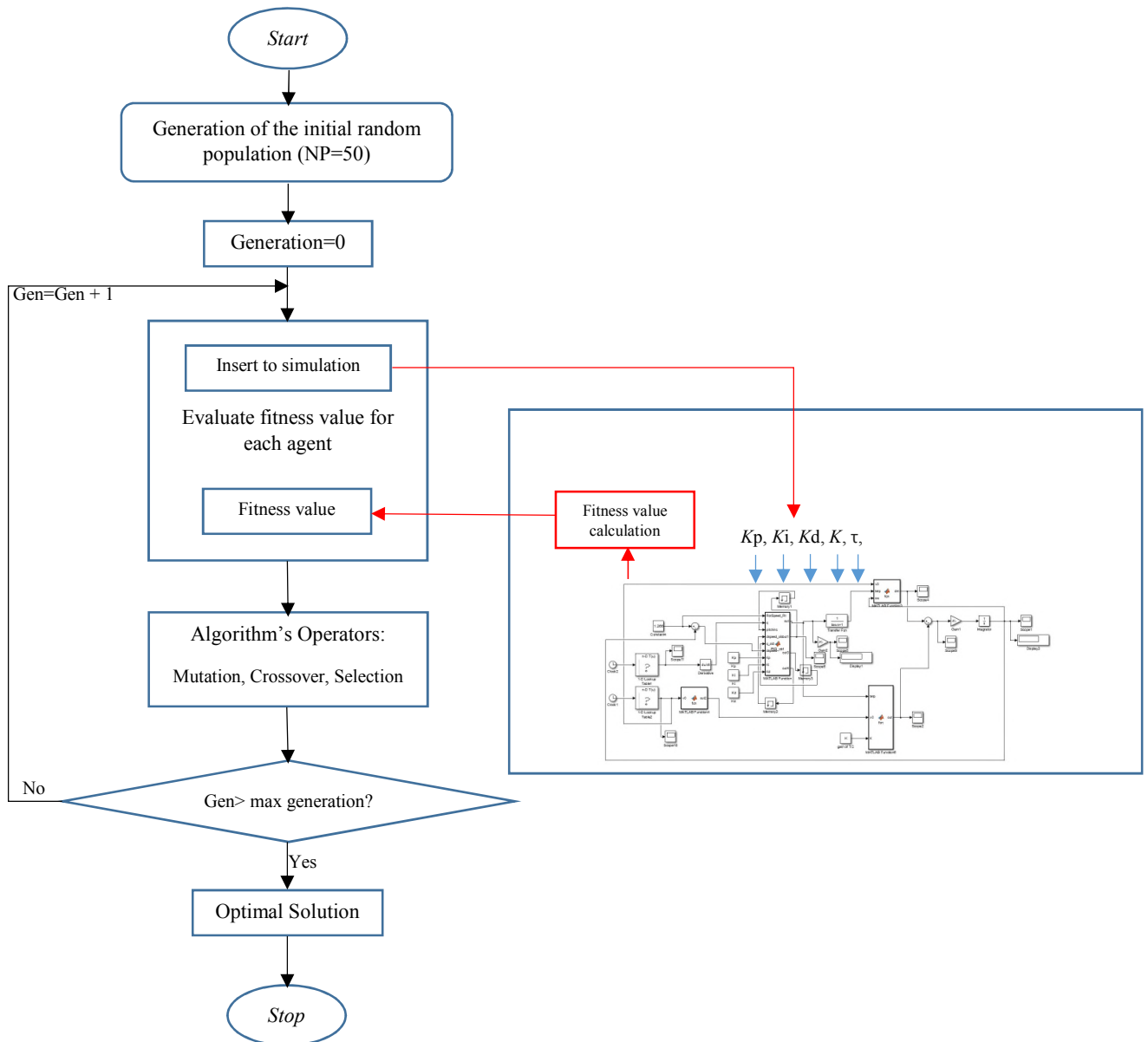

Fig. 9: Flowchart of Differential Evolution for wind turbine controller gain tuning

#### 4.2.2 Imperialist Competitive Algorithm (ICA)

Imperialist competition algorithm is an evolutionary optimization method starts with an initial population (N) which is called country, which be of, type being colonized ( $N_c$ ) or being imperialist ( $N_i$ ) [53]. The colonies of each empire get closer to the imperialist state (using assimilation rate and assimilation angle factor) and new space search is considered with the sudden random changes in the position of some of the countries in the search space (Using revolution rate). During these assimilations and revolutions, a colony might reach a better position than its

imperialist and grab the imperialist position. Then, weak empires would collapse during the algorithm procedure and powerful ones take possession of their colonies. Imperialist competition converges to a state in which there exists only one empire and colonies have the same cost function value as the imperialist.

The ICA's control parameters are set using the following rules [32,54] for the in-hand problem:

- 1- The number of initial population is set to 50 (10D)
- 2- The number of imperialists is usually set as 4-6% of all countries ( $N_i=3$ ). So,  $N_c = 50 - 3 = 47$
- 3- The assimilation rate, the assimilation angle, and the revolution rate are set to 1.8, 0.5, 0.2 respectively respect to the promising results and advices in [32,54]

It is worthwhile to mention that some other values for algorithm factors are also tested for the ICA algorithm. But, the above mentioned coefficients gave the best results for the in-hand problem.

The ICA algorithm is applied to the wind turbine problem as follow:

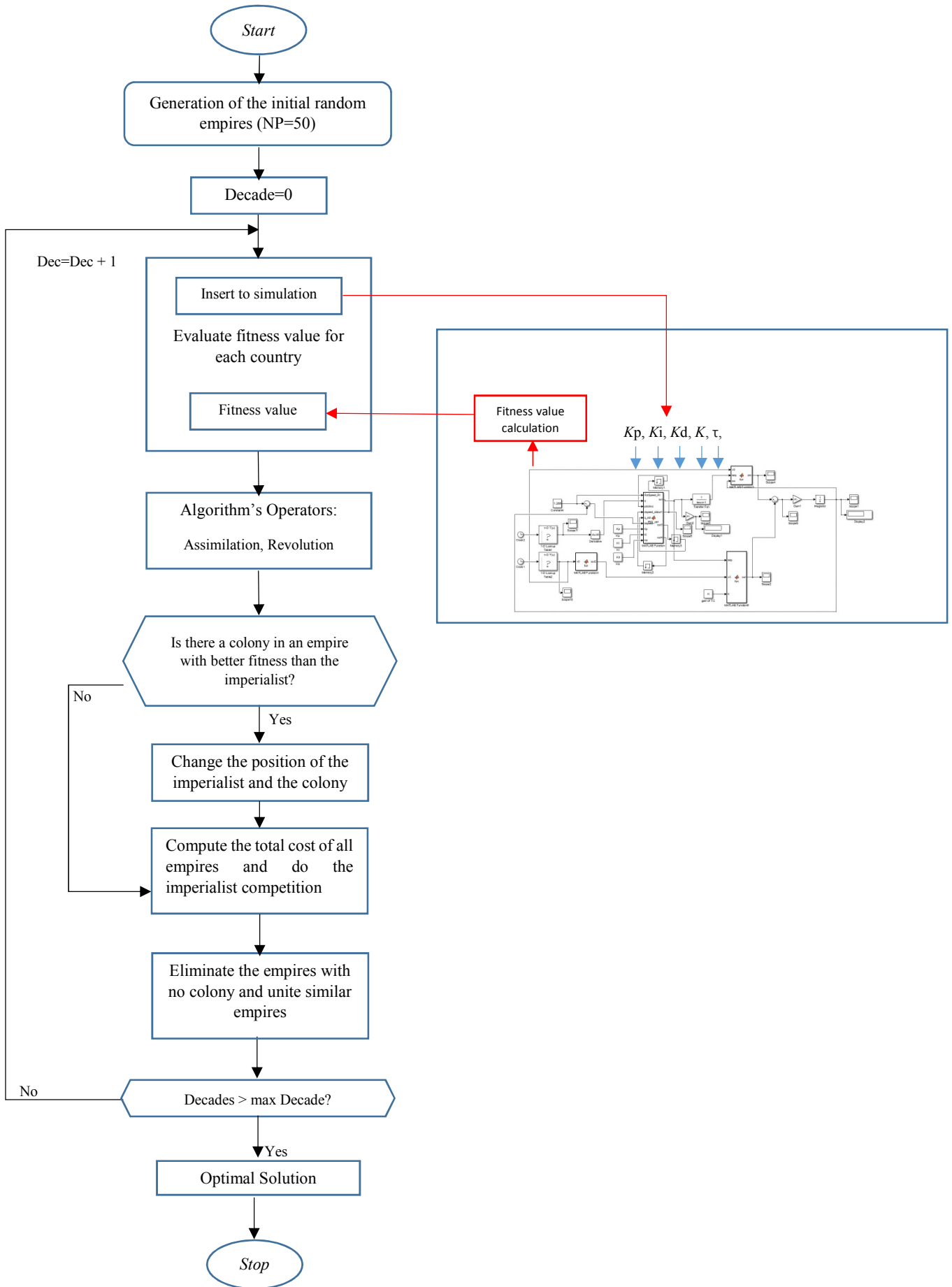

Fig. 10: Flowchart of Imperialist Competition Algorithm for wind turbine controller gain tuning

## 5 Optimization Results and Analysis

In this section, the results obtained from the gain tuning approaches (figures ...) are studied in order to confirm the effectiveness of the proposed method for the optimization of the wind turbine performance. Moreover, the wind turbine model with the optimized controller is simulated to analyze the results.

### 5.1 ICA and DE Results

In order to satisfy the reliability criterion, the optimization was run 15 times, and the average of the results are shown in this section. Moreover, the weight factors  $\gamma_i = 0.5$  are selected for the objective function terms in equation 6. It means that the importance of the objectives is equal in the optimization process. Optimization is terminated in the pre-specified number of generations/decades. In addition, the population size, the number of objective function evaluation, and stopping criterion are set to the same values in DE and ICA in order to compare the two approaches fairly.

- *Static convergence comparison*

Fig.11 shows the static convergence of the ICA algorithm where the mean solution is the average value of the fitness function evaluation by all population individuals in each decade and the best solution is the minimum of the objective function value achieved by the population in each decade. As shown in this figure, the ICA finds the optimized result of the problem in a reasonable manner and the algorithm is converged in 9 decades.

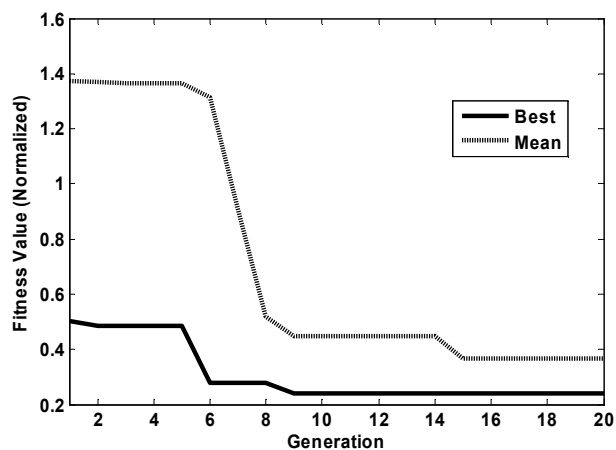

Fig.11: static convergence of ICA

Moreover, the similar runs are carried on with the DE algorithm and its result are compared with those of ICA. This comparison is shown in Fig.12. As shown in this figure, the DE can also find the best solution for the in-hand problem. Fig.12 also shows that the ICA exceeds DE in the term of static convergence rate for this problem as the DE converges in 15 generations. The obtained gains from both algorithms are shown in table 3. This table illustrates the ability of both algorithms in optimization of wind turbine controller gains.

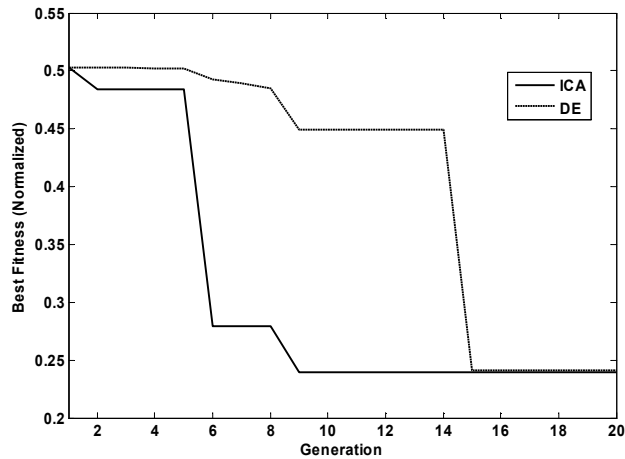

Fig12: comparison between ICA and DE static convergence rate

Table 3: Optimized controller gains

	$K_p$	$K_i$	$K_d$	$\tau$	$K$
<b>DE</b>	19.9810	19.6091	0.0081	0.4000	0.1810
<b>ICA</b>	20.0000	19.6092	0.0079	0.4000	0.1806

- **Dynamic convergence comparison**

Figure 13 compares the dynamic convergence rate of the ICA with that of DE. For this purpose, the standard deviation of the population in each generation/decade is saved and then plotted as a function of generation/decade. This procedure is done for a typical run. As shown in figure 13, dynamic convergence of the ICA method is better than that of DE because of the smoother changing in standard deviation of the population via generation variations. It is because of the different operators used in the algorithms and the nature of the algorithms as well.

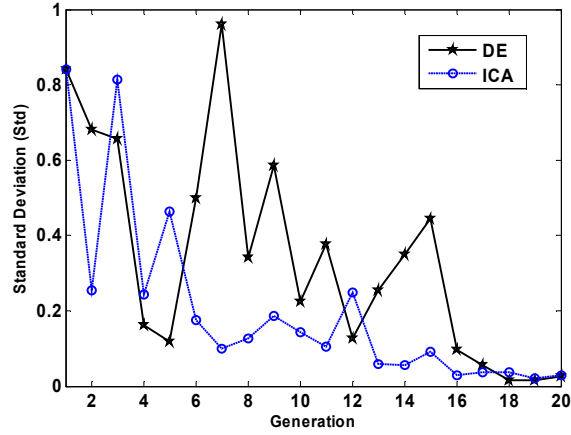

Fig.13: Comparison between dynamic convergence of ICA and DE

- **Computational effort comparison**

The computational effort of these algorithms for the in-hand problem is presented in table 4. This table states that the DE performs faster and therefore has a better computational effort index in this problem.

Table 4: Computational efforts of ICA and DE

	<i>Minimum run time (in 15 runs)</i>	<i>Maximum run time (in 15 runs)</i>	<i>Average of 15 runs</i>
<b>DE</b>	22:14	24:18	23:16
<b>ICA</b>	52:17	58:36	55:27

### 5.2 Effect of Optimization on the Wind Turbine Performance

In order to illustrate the effectiveness of the used optimization algorithms in minimizing the rise time and the steady state error of the wind turbine response, the developed model with the optimized controller is simulated in this section. For this purpose, the initial gains reported in [39] is simulated first. Then, the optimal gains calculated by the procedures of figures 9 and 10 (which were presented in table 3) are substituted in Simulink program (figure 7) and the results are compared. Fig 14 shows the results of simulation of wind turbine model with the initial and the ICA/DE optimized controller. As shown in this figure, the optimized controller achieves noticeably better rise time and also omits the small steady state error that the initial controller has. In addition, the wind turbine reached

to the desired output smoothly and without any overshoot (over-speed) in the response. So, the physical limitation control mode of the wind turbine is also satisfied by the optimization procedure.

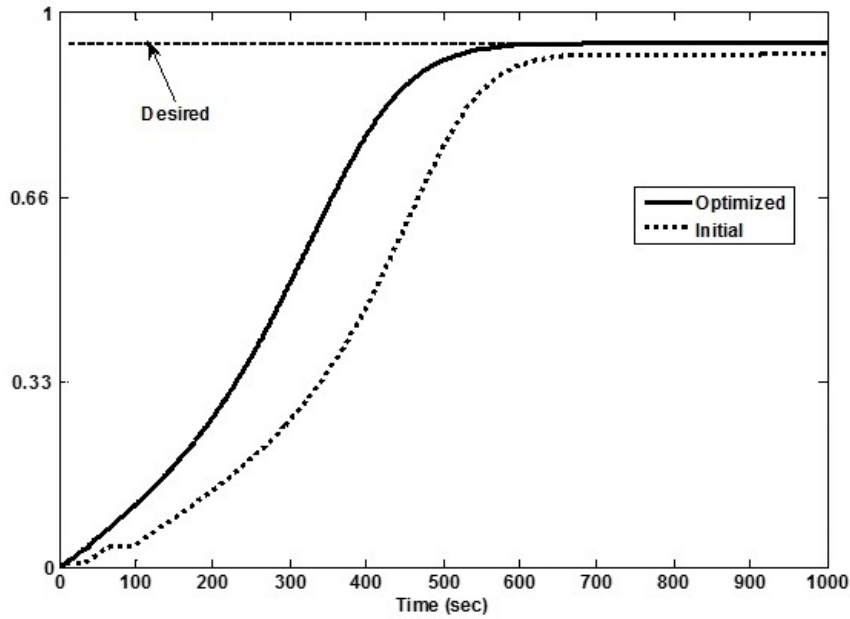

Fig.14: Effects of optimization on wind turbine controller performance

## 6. Conclusions

A methodological approach for the controller gain tuning problem in wind turbines was presented in this paper. For this purpose, the procedure of controller gain tuning was formulated as an engineering optimization problem in which minimizing the designer command tracking error and the turbine rise time created the objective function indices. Moreover, the physical limitations and considerations (over-speed and smooth control input) were added to define penalty function parts. The weighting factors and the penalty function coefficients were selected based on the designer priority and keeping potential solutions. In addition, taking the nonlinear behavior of the wind turbine and controller into account, meta-heuristic optimization algorithms were used to deal with the objective function. Application of the used algorithms in the defined problem was presented in a step-by-step flowchart feature. The results obtained from the ICA and DE in this paper, showed the ability and effectiveness of the used methods in successful gain tuning procedure of the wind turbine controller. Both methods were able to deliver an optimized controller that tracked the desired turbine rotor speed without any steady state error in a reasonable response time. Both methods also satisfied the turbine physical limitations control mode (e.g. overspeed and oscillatory response). The results obtained from the used algorithms showed that DE overcomes ICE from computational effort point of view whereas ICE is better than DE in both static and dynamic convergence criteria.



## References

- [1]. Soriano L.A, Yu W, and Rubio J, Review Article, Modeling and Control of Wind Turbine. Hindawi Publishing Corporation, Mathematical Problems in Engineering, Volume 2013 (2013), Article ID 982597, 13 pages, <http://dx.doi.org/10.1155/2013/982597>
- [2]. Pozo F, Vidal Y, Acho L, Luo N, Zapateiro M, Power Regulation of Wind Turbines Using Torque and Pitch Control, in 2013 American Control Conference (ACC) Washington, DC, USA, June 17-19, 2013, 978-1-4799-0178-4/\$31.00 ©2013 AACC
- [3]. Bianchi F, Fernando D, de Battista, Hernán, Mantz, Ricardo J., Wind Turbine Control Systems Principles Principles, Modelling and Gain Scheduling Design. ISBN 978-1-84628-493-9, Springer: La plata, Argentina. 2006.
- [4]. Erlich I, Shewarega F, Feltes C, Koch F.W, and Fortmann J, Offshore wind power generation technologies, Proceedings of the IEEE, vol. 101, pp. 891–905, 2013.
- [5]. Ofualagba G, Ubeku E.U, Wind energy conversion system-Wind turbine modeling, in Proceedings of the IEEE Power and Energy Society General Meeting: Conversion and Delivery of Electrical Energy in the 21st Century, 10.1109/PES.2008.4596699 , PES, pp. 1–8, July 2008.
- [6]. Michalke G, Hansen A.D, Modelling and control of variable speed wind turbines for power system studies, Wind Energy, vol. 13, no. 4, pp. 307–322, 2010, DOI: 10.1002/we.341
- [7]. Bolik S. M, Modelling and Analysis of Variable Speed Wind Turbines with Induction Generator during Grid Fault. Aalborg Universitet: Institut for Energiteknik, Aalborg Universitet. 2004
- [8]. Heier S, Grid Integration of Wind Energy: Onshore and Offshore Conversion Systems, 3rd Edition. ISBN: 978-1-119-96294-6, JohnWiley & Sons. 2014.

- [9]. Muyeen, S. M., Shishido, S., Ali, Mohd. H., Takahashi, R., Murata, T. and Tamura, J., Application of energy capacitor system to wind power generation. *Wind Energ.*, 11: 335–350. doi:10.1002/we.265, 2008
- [10]. Rol'an A, Lee A, V'azquez G, Aguilar D, Azevedo G. Modeling of a variable speed wind turbine with a permanent magnet synchronous generator. in *Proceedings of the IEEE International Symposium on Industrial Electronics (IEEE ISIE '09)*. July 2009.
- [11]. Stuart J D, Wright A D, Butterfield C P, Wind turbine control systems: dynamic model development using system identification and the fast structural dynamics code, in *Proceedings of the American Society of Mechanical Engineers wind energy symposium*, Reno, Nevada, USA, 1997.
- [12]. Ressor B R, Definition of a 5MW/61.5m Wind Turbine Blade Reference Model, SANDIA REPORT SAND2013-2569, Unlimited Release, April 2013
- [13]. Pierce K, Jay Fingersh L. Wind turbine control system modelling capabilities. in *Proceedings of the American Controls Conference*. Philadelphia, Pa, USA. June1998.
- [14]. Munteanu I, Cutululis N-A, Iuliana Bratcu A, Ceangă E, Optimal Control of Wind Energy Systems Towards a Global Approach, ISBN: 978-1-84800-079-7 (Print) 978-1-84800-080-3 (Online) *Advances in Industrial Control*. Springer: New York, NY, USA. 2008.
- [15]. Holley W.E, Wind turbine dynamics and control—issues and challenges. in *Proceedings of the American Control Conference*. Pleasanton, CA, June 2003.
- [16]. Gregor E, van Baars and Peter M.M. Wind turbine control design and implementation based on experimental models. in *Proceedings of the 31st IEEE Conference on Proceedings of the Decision and Control*. 1992.

- [17]. Darrow, P.J., Wind Turbine Control Design to Reduce Capital Costs. National Renewable Energy Laboratory (NREL) report. 2009.
- [18]. Jason H. Laks L.Y. and Alan D. Wright, Control of Wind Turbines: Past, Present, and Future. National Renewable Energy Laboratory (NREL) report: University of Colorado at Boulder. 2009.
- [19]. Horiuchi N, Kawahito T. Torque and Power Limitations of Variable Speed Wind Turbines Using Pitch Control and Generator Power Control, in Takamatsu National College of Technology 355 Chokushi-cho. IEEE: Takamatsu City, Japan. 0-7803-7173-9/01/ 2001
- [20]. Dunnea F, Lucy Y. Paoa, Alan D. Wrightb, Bonnie Jonkmanb, Neil Kelley, Adding feedforward blade pitch control to standard feedback controllers for load mitigation in wind turbines Mechatronics. Mechatronics 21 (2011) 682–690
- [21]. Muyeen A M, Tamura J, Murata T, Stability Augmentation of a Grid-Connected Wind Farm, Green Energy and Technology, Springer, New York, NY, USA, 978-1-84800-315-6 (Print) 978-1-84800-316-3 (Online), 2009.
- [22]. Malinga B, Sneckenberger J E, Feliach A, Modeling and control of a wind turbine as a distributed resource,” in Proceedings of the 35th Southeastern Symposium on System Theory, pp. 108–112, 0-7803-7697-8/03/\$17.00 0 2003 IEEE.
- [23]. Senjyu T, Sakamoto R, Urasaki N, Funabashi T, Fujita H, Sekine H, Output power leveling of wind turbine generator for all operation regions by pitch angle control. IEEE TRANSACTIONS ON ENERGY CONVERSION, VOL. 21, NO. 2, JUNE 2006
- [24]. Chiu S L., Fuzzy model identification based on cluster estimation. Journal of Intelligent and Fuzzy Systems 2(3):267-278 · January 1994

- [25]. Beltran T, Ahmed-Ali T, Benbouzid M E, Haddoun A, Sliding mode power control of variable speed wind energy conversion systems, in Proceedings of the IEEE International Electric Machines and Drives Conference (IEMDC '07), pp. 943– 948, May 2007.
- [26]. Utkin V I, Sliding Modes in Control and Optimization, Communications and Control Engineering Series, Springer, Berlin, Germany, ISBN 978-3-642-84379-2, 1992.
- [27]. Stol K A, Zhao W, Wright A D, Individual Blade Pitch Control for the Controls Advanced Research Turbine (CART), J. Sol. Energy Eng 128(4), 498-505 (Jul 26, 2006) (8 pages), doi:10.1115/1.2349542.
- [28]. Celis C, Sethi V, Singh R, Pilidis P, On Optimisation of Environmentally Friendly Aircraft Engine Cycles, J. Aerosp. Technol. Manag., São José dos Campos, Vol.7, N 2, pp.143-156, Apr.-Jun., 2015
- [29]. Wanis M, Techno-Economic, Environmental and Risk Analysis (TERA) for Power Generation, PhD thesis, School of Engineering, Department of Power and Propulsion, Academic Year: 2012 - 2013
- [30]. Global Optimisation of Mixed-Integer Nonlinear Programs, Imperial College London, Department of Computing, Quantitative Analysis and Decision Science, ongoing project, Ruth Misener, <http://wp.doc.ic.ac.uk/rmisener/project/global-optimisation-of-mixed-integer-nonlinear-programs/>
- [31]. Mixed Integer Optimization, ETH Zurich, Institute for Operations Research, ongoing project, Robert Weismantel, <https://www.math.ethz.ch/ifor/research/mixed-integer-optimization.html>
- [32]. Atashpaz-Gargari E, Lucas C. Imperialist Competitive Algorithm: An algorithm for optimization inspired by imperialistic competition. IEEE Congress on Evolutionary Computation. pp. 4661–4666. 2007
- [33]. Storn R, Price K V, Differential evolution-A simple and efficient heuristic for global optimization over continuous Spaces, Journal of Global Optimization, December 1997, Volume 11, Issue 4, pp 341–359 1997.

- [34]. Safari A, Lemu G H, Jafari S, Assadi M, A Comparative Analysis of Nature-Inspired Optimization Approaches to 2D Geometric Modelling for Turbomachinery Applications, *Mathematical Problems in Engineering*, Volume 2013 (2013), Article ID 716237, 15 pages <http://dx.doi.org/10.1155/2013/716237>
- [35]. Behera A , Panda S, Prakash T, Biswal S. Design and performance analysis of a PID controller by using Differential Evolutionary Algorithm for an Autonomous Power System. *International Journal of Advances in Electrical and Electronics Engineering*, ISSN: 2319-1112, ISSN: 2319-1112 /©IJAEED , 2013
- [36]. Saad M S, Jamaluddin H, Darus I M, PID Controller Tuning Using Evolutionary Algorithms, *WSEAS TRANSACTIONS on SYSTEMS and CONTROL*, E-ISSN: 2224-2856, Issue 4, Volume 7, October 2012
- [37]. Shuai L, Wei S, Design of Fuzzy Logic Controller Based on Differential Evolution Algorithm. *Computational Intelligence, Networked Systems and Their Applications*, Volume 462 of the series *Communications in Computer and Information Science* pp 18-25, 2014
- [38]. Goudos S K, Zaharis Z D, Yioultis T V. Application of a differential evolution algorithm with strategy adaptation to the design of multi-band microwave filters for wireless communications. *Progress in Electromagnetics Research*, Vol. 109, 123–137, 2010
- [39]. Jonkman J, Butterfield S, Musial W, Scott G, Definition of a 5-MW Reference Wind Turbine for Offshore System Development, National Renewable Energy Laboratory (NREL) report. 75. NREL/TP-500-38060, 2009.
- [40]. Jasniewicz (Fischer) B, Geyler M, Wind turbine modelling and identification for control system applications. *EWEA 2011, Scientific Proceedings*, pp. 280-284, 2011.

- [41]. Luo, Ningsu, Vidal, Yolanda, Acho, Leonardo (Eds.), Wind Turbine Control and Monitoring, ISBN 978-3-319-08413-8, 2014
- [42]. Jafari S, Montazeri-Gh M. Evolutionary Optimization for Gain Tuning of Jet Engine Min-Max Fuel Controller, Journal of Propulsion and Power, Vol. 27, No. 5 (2011), pp. 1015-1023.  
<http://dx.doi.org/10.2514/1.B34185>
- [43]. Åström K J, Hägglund T, PID Controllers - Theory, Design, and Tuning, ISBN978-1-55617-516-9, 1995
- [44]. Jafari S, Khalaf P, Montazeri-Gh M, Multi-Objective Meta Heuristic Optimization Algorithm with Multi Criteria Decision Making Strategy for Aero-Engine Controller Design, International Journal of Aerospace Sciences 3 (1), 6-17, 2014
- [45]. Wind turbine control methods, National instrument white papers, Publish Date: Dec 22, 2008
- [46]. Montazeri-Gh M, Yousefpour H, Jafari S, Fuzzy logic computing for design of gas turbine engine fuel control system, Computer and Automation Engineering (ICCAE), 2010 The 2nd International Conference on, Singapore, 2010, pp. 723-727.  
doi: 10.1109/ICCAE.2010.5451342
- [47]. Pierce K and Jay L, Wind turbine control system modeling capabilities, in Proceedings of the American Controls Conference, pp. 24–26, Philadelphia, Pa, USA, June 1998
- [48]. Castaignet D, Poulsen N K, Buhl T, Wedel-Heinen J J, Model predictive control of trailing edge flaps on a wind turbine blade, in Proceedings of the American Control Conference (ACC '11), pp. 4398–4403, July 2011.

- [49]. Hegerty B, Hung C-C, Kasprak K. A comparative study on differential evolution and genetic algorithms for some combinatorial problems. in Proceedings of 8th Mexican International Conference on Artificial Intelligence. 2009.
- [50]. Storn, R. On the usage of differential evolution for function optimization. Biennial Conference of the North American Fuzzy Information Processing Society (NAFIPS). pp. 519–523. 1996
- [51]. Price, K.; Storn, R.M.; Lampinen, J.A. Differential Evolution: A Practical Approach to Global Optimization. Springer. ISBN 978-3-540-20950-8., 2005
- [52]. Liu, J.; Lampinen, J. On setting the control parameter of the differential evolution method. Proceedings of the 8th International Conference on Soft Computing (MENDEL). Brno, Czech Republic. pp. 11–18. 2002
- [53]. Nazari-Shirkouhi S, Eivazy H, Ghodsi R, Rezaie K, Atashpaz-Gargari E. Solving the Integrated Product Mix-Outsourcing Problem by a Novel Meta-Heuristic Algorithm: Imperialist Competitive Algorithm. Expert Systems with Applications 37 (12): 7615–7626. doi:10.1016/j.eswa.2010.04.081.
- [54]. Biyantoa T R, Khairansyahab M, Bayuajic R, Firmantod H, Haksoroa T. Imperialist Competitive Algorithm (ICA) for Heat Exchanger Network (HEN) Cleaning Schedule Optimization. Procedia Computer Science 72 (2015) 5 – 12 .committee of Information Systems International Conference (ISICO2015) doi: 10.1016/j.procs.2015.12.099

# Advanced modelling and control of 5MW wind turbine using global optimization algorithms

Jafari, Soheil

2018-10-29

Attribution-NonCommercial 4.0 International

---

Jafari S, Pishkenari MM, Sohrabi S, Feizarefi M. (2019) Advanced modelling and control of 5 MW wind turbine using global optimization algorithms. *Wind Engineering*, Volume 43, Issue 5, October 2019, pp. 488-505

<https://doi.org/10.1177/0309524X18807471>

*Downloaded from CERES Research Repository, Cranfield University*