

**Direct and converse Magnetolectric Effect
in Laminate Bonded Terfenol-D - PZT Composites**

P Record; C Popov, J Fletcher, E. Abraham;
Heriot-Watt University, School of EPS, Electronics Department, Edinburgh EH14 4AS
Z. Huang, H. Chang, R.W. Whatmore
Department of Advanced Materials, SIMS, Cranfield University, Beds, MK43 0AL, UK

Abstract: Results from measurements of the direct and converse magnetolectric effect on a three-layer, epoxy-bonded, laminate composite are presented. The laminae are a single transversely-polarised piezoelectric elements (PZ29) sandwiched between two longitudinal-magnetically polarised magnetostrictive TD elements (Terfenol-D – TX GMM). The direct ME effect was determined by measuring laminate output with a Helmholtz-generated AC field (of up to 7Oe) in the range 50 Hz – 100 kHz biased by a DC field (0 – 1000Oe). Peak voltage output occurred at the sample's mechanical resonant frequency, its value otherwise depending on the strength and direction of the applied magnetic field. The peak output is 3061mV at 3 Oe AC field and 1000 Oe bias, equivalent to 74.4 V/cm Oe was achieved. The peak output coefficient, however was 93.6V/cm Oe at 0.1Oe AC field and 1000Oe DC bias. The reduction at higher drive amplitudes was attributed an increased Young's modulus of TD phase. Anomalous peaks in the sample's output, related to the proximity of the DC electromagnet poles, are also investigated and explained. The converse magnetolectric effect was measured by recording the voltage induced in a solenoid encompassing the ME and exposed to a DC bias field and the PZ phase driven by a 10 V_{AC} source. A peak output is shown to depend on the strength of the applied DC magnetic field and gave a maximum output voltage of 600 mV, representing 15.4 Oe at the sample's mechanical resonant frequency. This equates to a converse magnetolectric coefficient of 55 Oe cm/ kV.

Keywords: Magnetolectric effect; Magnetolectric Composites; Magnetostriction; Piezo-electricity;
MEMS;

Introduction: The Magnetolectric effect represents the coupling between an applied magnetic field and a change in electric polarization in a solid. While the effect can occur in single phase materials, such as Cr₂O₃, it is usually small. Much larger effects can be obtained in composites consisting of two functional phases – a magnetostrictive material, in which a strain is produced by application of a magnetic field, coupled to a piezoelectric material, in which a change in electric polarization is produced by an applied stress. Reciprocally, an electric field applied to the piezoelectric phase of such a composite will cause a change in the magnetization of the magnetostrictive phase – described here as the Converse Magnetolectric effect. The magnetolectric effect is generally characterized by the Magnetolectric Voltage Coefficient:

$$\alpha_E = \frac{\partial E}{\partial H} \quad \text{V Oe}^{-1} \text{ m}^{-1}$$

Likewise, the inverse magnetolectric effect, being the exact reversed process would be characterized by an inverse coefficient:

$$\beta_M = \frac{dH}{dE} \quad \text{Oe m V}^{-1}$$

A variety of materials have been used to produce magnetolectric composites; comprehensively reviewed in the works of M. Fiebig¹ and of J. Ryu et al². These authors conclude that the best magnetostrictive material in this case was Terfenol-D and the best piezoelectric material was PMN-PT. Reported magnetolectric research in literature on the latter is sparse, perhaps owing to the very high commercial price of the PMN-PT. The most commonly used piezoelectric material in current research¹⁻⁹ is the lead zirconium titanate, PZT, having suitable characteristics for magnetolectric applications. A variety of ferrites have been used as a magnetostrictive phase,

generating however a much smaller ME effects^{1,2}. The application of Permendur, an iron/cobalt/vanadium alloy, as the magnetostrictive phase has been presented only by Laletsin et al^{1,3} with impressive results. Being known as the best magnetostrictive material, the application of Terfenol-D in magnetoelectric composites has been preferred by many researchers¹⁻⁹. This material is brittle and prone to oxidation making manufacture of specific shapes and thicknesses difficult., however, reports for methods of producing films of Terfenol-D by N. Cai et al⁴ and W. Zhang et al¹⁰, may provide a solution for these problems in the future.

Most research groups investigating the ME effect expose the sample to DC bias with superimposed AC field magnetic fields¹⁻⁷. An alternative method, presented by J Huang et al⁸ and A Bayrashev et al⁹ involves a low frequency vibration of a DC magnetic field source in close proximity to a magnetoelectric sample. The highest magnetoelectric voltage coefficient so far has been achieved by Laletsin et al³, reporting $90 \text{ V Oe}^{-1} \text{ cm}^{-1}$, yielded by a tri-layered sample of Permendur/ PZT/ Permendur. To the authors' knowledge, no experimental results on the converse magnetoelectric effect have been reported.

In single phase materials the magnetoelectric effect is a material property, the magnetoelectric effect in laminate composites, however, is regarded as a product property^{1,2}. The magnitude of this effect depends on factors, such as; magnetostrictive and piezoelectric phase composition, thickness ratio between the phases, pre-stress, poling direction, magnetic field strength and direction. A finite element analysis on the sensitivity of magnetoelectric composites in relation to geometric configuration and thickness of the phases, orientation of magnetization and polarization of magnetostrictive and piezoelectric layers, has been presented by G. Liu et al⁵. The authors conclude that the magnitude of the magnetoelectric voltage coefficient

depends on the overall thickness and length of the sample and the thickness ratio of the magnetostrictive and piezoelectric phases ^{1 - 3, 5, 6}. This is confirmed by a theoretically analysis by one of our group ¹². In addition, the highest magnetoelectric output is achieved when the magnetic field is being applied in the same direction as the polarisation of the piezoelectric phase. This was confirmed by S. Dong et al ⁶ with a similar composite design. By using finite element modelling of a bi-layer Terfenol-D/PZT composite X Liu et al ⁷ demonstrated there was a phase thickness ratio and frequency dependence of the magnitude of the magnetoelectric output. The resonant magnetoelectric effect, attributed to the electro-mechanical resonance of the sample ¹⁻³, has been reported to generate the largest magnetoelectric response.

The advantages of the magnetoelectric composites over single phase materials and the possible practical applications of the magnetoelectric effect are widely discussed ^{1 - 9}. In the current state of research however major advances in material processing need to occur before miniaturization of the samples can be used for MEMS applications.

Materials and Sample preparation: Tri-layer laminated composites of Terfenol-D/PZT/ Terfenol-D and PZT /TD/ PZT were prepared by epoxy bonding using commercially purchased poled PZT (PZ29) and magnetised Terfenol-D (TX GMM) wafers. Meso-scale magneto-electric samples, with total thickness of 1.262 mm were fabricated by polishing down the Terfenol-D and the PZT elements and then cutting the laminated composites. They were bonded by epoxy, (EPOTEK301-2) at 85 deg. C for 150 minutes. The results presented here are for a tri-layered, transversely-polarised piezoelectric element (PZ29) sandwiched between two longitudinal magnetically

polarised magnetostrictive elements (TX GMM) with dimensions $L=15\text{mm}/T=1.262\text{mm}/W=2.5\text{mm}$. The PZT thickness was measured to be 0.137 mm, with two equally thick plates of Terfenol-D (0.560 mm), with the PZT occupying 12.25% of the overall sample. Prior to testing, the resonant frequency of the sample was measured, using a circuit shown in figure 1, left insert. Figure 1, right inset, displays the electromechanical resonance of one sample with 1.5Vac test voltage. Prior to magnetolectric testing, the sample was suspended between two electrodes, each attached by means of conductive epoxy to the centres of the two outer plates of the test specimen, figure 3b. This type of mounting allows physical restrictions on the sample to be reduced to a minimum, which compared to stiffer sample holders increases the voltage output some 30%.

Equipment and experimental set-up: The installation for measuring the direct magnetolectric effect is shown schematically, in figure 3a. This consists of an electro-magnet providing DC magnetic field in a 0 – 1000 Oested range, a pair of Helmholtz coils powered by a linear power amplifier, providing AC magnetic field in a 0 – 7 Oested range and recording equipment over the frequency of 0 -100kHz. The Helmholtz coil pair field output was calibrated both in AC and DC mode, by direct measurements with a Linear Output Hall Effect Transducer (LOHET SS94A2D) Hall Effect probe. These measurements were compared to theoretically calculated values, using equation derived from the Biot-Savart law where the flux density, given by

$$B = \frac{8\pi NI10^{-7}}{R_c \sqrt{125}}, \text{ where}$$

N is the number of turns; I is the current; and R_c is the coils radius. A Hirst Fluxmaster FM70 with Radcliffe Magtronics Ltd Hall Effect probe and the LOHET probe were

used to measure the DC and AC magnetic fields respectively. Early reports of composite ME below resonance reported a peak at around 200Hz this was found to be an artefact generated by the proximity of the iron pole pieces of the electro-magnet to the Helmholtz coil pair, figure 4.

For all magnetoelectric experiments presented here, the electromagnet poles and the coils were arranged in such a way, so that the AC and DC magnetic fields are parallel in direction, figure 3a. The tested composite, mounted on a holder as shown on *figure 03b*, was positioned centrally between the DC electromagnet poles on the Helmholtz coils axis, so that the fields direction were transverse to the poling direction of the PZT and parallel to the Terfenol-D magnetisation direction. The magnetoelectric sample was exposed to DC magnetic field strengths in a 50 – 1000 Oersted range and AC magnetic field strengths in a 1 – 5 Oersted range, in various combinations. At high AC fields the inductance of the Helmholtz pair generates a prohibitively large voltage at frequencies $> 10\text{kHz}$ so for frequencies above 10kHz the inductance was tuned out by series variable capacitance. The total capacitance required to put the coils in resonance was calculated from inductance and resistance measured with Fluke RCL Bridge PM6306. For frequencies below 10kHz the Helmholtz coil pair was driven directly.

The tests for the converse magnetoelectric effect were conducted by directly driving the sample piezoelectric phase by a signal generator and measuring the voltage induced in a solenoid which encompassed the sample. The solenoid was long enough to neglect the end effects. The flux was then estimated from the induced voltage.

Results and Discussion: During the calibration of Helmholtz coils, a possibility was considered that by positioning the coils in close proximity to the DC electromagnet poles would influence the results of the ME tests. Indeed, the results, shown in figure 4 demonstrate that the size and proximity of the poles affect the inductance of the coils, especially at low frequencies, the inductance peak however, as expected, was not related to the DC magnetic field strength applied by the electromagnet. A peak of the same bandwidth was discovered during initial magnetoelectric testing, figure 5, its existence and size depending on the DC poles separation, misleadingly suggesting a peak of magnetoelectric activity at low frequencies. This may be a source for possible error in publications claiming that a magnetoelectric output peak occurs in the 50 – 400 Hz region. A distance between the poles of 6 cm reduced the artefact to a negligible amount and was adhered to for all subsequent experiments.

The shift in capacitance shown in figure 2 can be explained by accounting the change in stress induced by the DC magnetic field applied to the sample. Similar frequency shifting effect was observed during direct and converse magnetoelectric tests figure 6,7. The non-monotonic change in resonant suggests that stress is first relieved at low fields but increases at high fields.

The results for the lower frequency range, figure 05 - blue line, show that the voltage output of the sample is low and flat throughout this range. Similar results, with variation of only by 5 – 10 mV were obtained for all combinations of DC/AC magnetic fields experiments. The red line on the same chart represents the dependency of the results in this range to the proximity of the Helmholtz coils to the DC poles that was already discussed in the paragraph above. The results from the upper frequency range, figure 7, show that the highest voltage output always occurs at, or close to the sample's mechanical resonance frequency, its value otherwise depending on the

strength and direction of the applied magnetic fields. Although not thoroughly tested, it was established that when the sample was positioned in such a way that The PZT poling direction was parallel to the magnetic fields direction, the magnetoelectric voltage output was reduced with some 60%. This result seems to be in agreement with the findings of other researchers ^{1,3}. For the sample presented, the highest output was achieved with 1000 Oested DC magnetic field, with an increase of the AC magnetic field amplitude, proportionally increasing the sample output, figure 8. The highest voltage output recorded was 3051mV, corresponding to Magnetoelectric Voltage Coefficient value of $74.4 \text{ V cm}^{-1} \text{ Oe}^{-1}$, demonstrating its capability for a micro-power source. The maximum ME coefficient, of $94 \text{ V cm}^{-1} \text{ Oe}^{-1}$ occurred, however, at a lower drive field of 0.05Oe, figure 8.

The results from the converse magnetoelectric tests, figure7 also confirm that the highest magnetoelectric activity occurs at the sample's resonance frequency and its size is dependant of the strength of the applied DC magnetic field.

Devices results

One of the drivers for these studies was providing power remote to small electronic devices. It was thought that conventional inductive powering of RFID tags and MEMS could be achieved by a magneto-electric elements. The target power for a UHF transponding tag was estimated to be $50\mu\text{W}$. To this end a tri-layar sample consisting of PZ, TD,PZ, similar to that described above, was placed in throat of a 5 cm diameter Helmholtz coil pair. The DC magnetic field bias was provide by an electro-magnet allowing field of up 1000Oe to be applied.. The output from the PZ element was coupled to Schottky diode bridge via an inductor, figure9a,b . The

inductor was adjusted to match the reactance of the PZ element capacitance. For a 1 Oe AC field and open circuit voltage of 28 V and a short circuit current of 60uA was produced. At a load voltage of 3V approximately 110uW of power was developed for 1 Oe AC drive. For maximum power transfer the device was operated in electromechanical resonance. It will be noted that even at ½ AC field drive the target power still was met. The second driver for this work was a low field sensor and in particular to allow near field communication in which device demonstrating the Converse ME effect would be the transmitter and the direct ME effect would be the receiver. The sensitivity of the latter is shown in figure 10, where field as low as 1nT are readily detected. Interestingly, in most countries of the world local time is sent encoded on low frequency RF bands span 10 – 80kHz. The estimated flux density at 200km distant from a 15kW transmitter operating at 60kHz was 158nG so these devices could readily detect this signal.

Conclusions: The direct and inverse magnetoelectric effect of a tri-layer Terfenol-D/PZT/ Terfenol-D magnetoelectric composite sample has been investigated, achieving results of $94 \text{ V cm}^{-1} \text{ Oe}^{-1}$ for the and 55 Oe cm kV^{-1} for the direct and converse magnetoelectric voltage coefficients respectively. It was observed that the voltage output in both cases occurs at the sample's electro-mechanical frequency point. Anomalous peaks at low frequencies were detected and explained. The sample's capabilities to be used as a micro-power source were demonstrated in a simple device prototype, achieving 110 uW of rectified power. The results from the converse magnetoelectric tests demonstrate that magnetoelectric composite samples can be used

in MEMS applications, not only as power generator source, but also a transducer for half-duplex communication.

References:

1. ; J. Ryu et al. Magnetolectric Effect in Composites of Magnetostrictive and Piezoelectric Materials; Journal of Electroceramics, 8, (2002) 107–119
2. ; Manfred Fiebig. Revival of the magnetolectric effect; J. Phys. D: Appl. Phys. 38 (2005) 123–152
3. U. Laletsin et al. Frequency dependence of magnetolectric interactions in layered structures of ferromagnetic alloys and piezoelectric oxides; Appl. Phys. A 78, (2004) 33–36
4. Ning Cai et al. The magnetolectric properties of lead zirconate titanate/terfenol-D/ PVDF laminate composites;;Materials Science and Engineering B 99 (2003) 211-213
5. Gang Liu et al. Calculations of giant magnetolectric effect in multiferroic composites of rare-earth-iron alloys and PZT by finite element method; International Journal of Solids and Structures 41 (2004) 4423–4434
6. Shuxiang Dong. Longitudinal and Transverse Magnetolectric Voltage Coefficients of Magnetostrictive/Piezoelectric Laminate Composite: Theory; IEEE Transactions on Ultrasonics, Ferroelectrics, and Frequency Control, Vol. 50. No. 10, 2003
7. Y.X. Liu et al. Numerical modeling of magnetolectric effect in a novel composite structure; Ceramics International 30 (2004) 1999–2003
8. J. Huang et al. New, high-sensitivity, hybrid magnetostrictive/electroactive magnetic field sensors;; Proceedings of SPIE Vol. 5050 (2003)
9. Andrey Bayrashev et al. Low frequency wireless powering of microsystems using piezoelectric–magnetostrictive laminate composites;; Sensors and Actuators A 114 (2004) 244–249
10. Wenxu Zhang et al. Preparation and characterization of thick magnetostrictive films;; Journal of Magnetism and Magnetic Materials 261 (2003) 118–121
- 11 M.I. Bichurin and V.M. Petrov. Theory of low frequency magnetolectric coupling in magnetostrictive-piezoelectric bilayers, Phys. Rev. B: 1 Aug. 2003
- 12 Z. Huang. “Magnetization by Electric Field Through Product Property: Theoretical Modelling”, submitted to J. Appl. Physics, 4 April 2006.

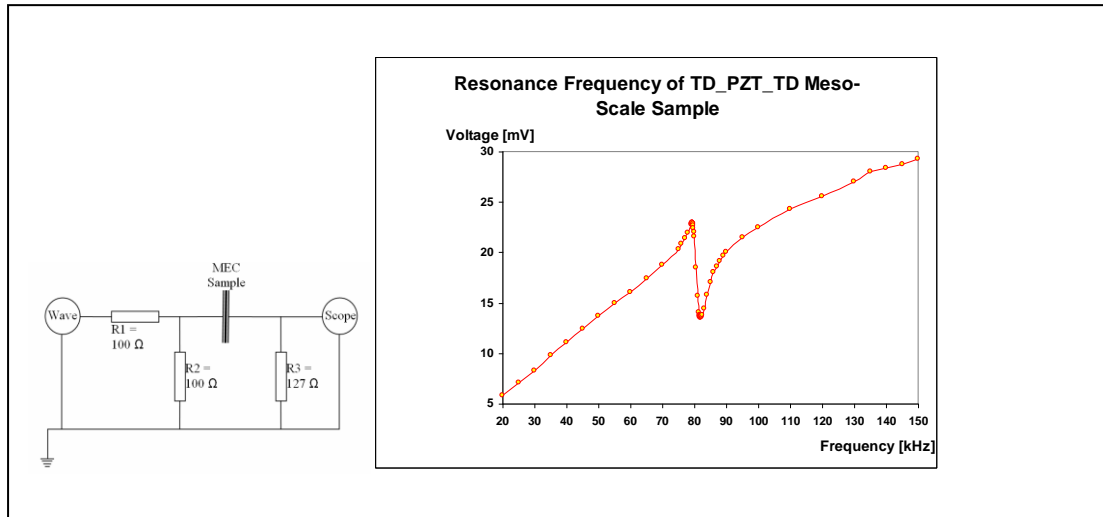

Figure 1 test circuit and corresponding response showing electromechanical resonance

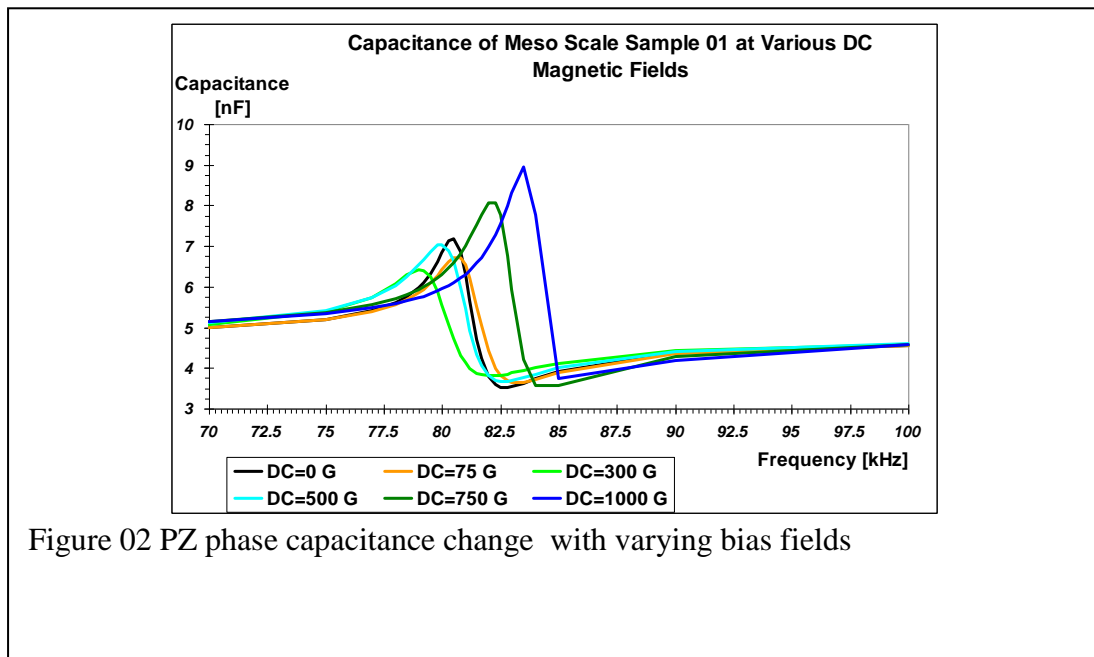

Figure 02 PZ phase capacitance change with varying bias fields

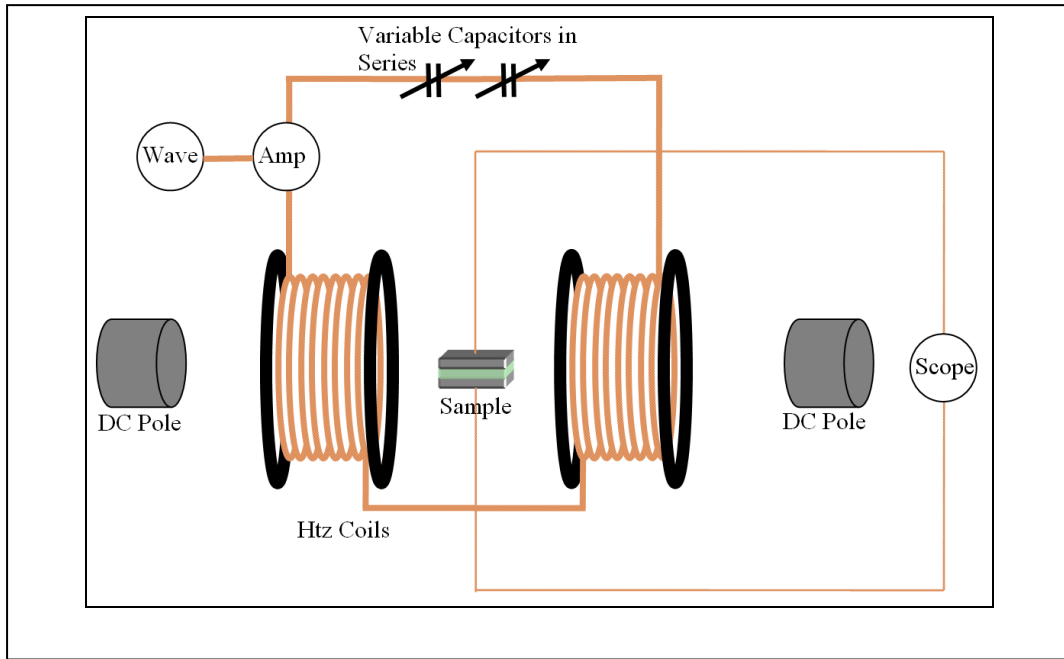

Figure 3a : Schematic for the test facility to measure sample ME response

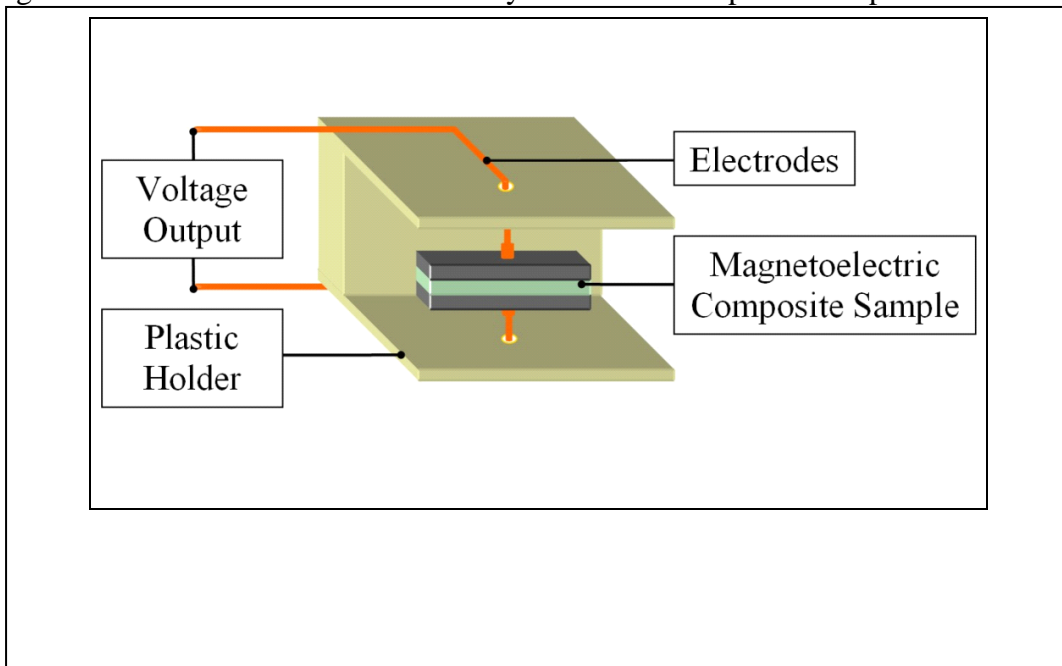

Figure 3b sample holder

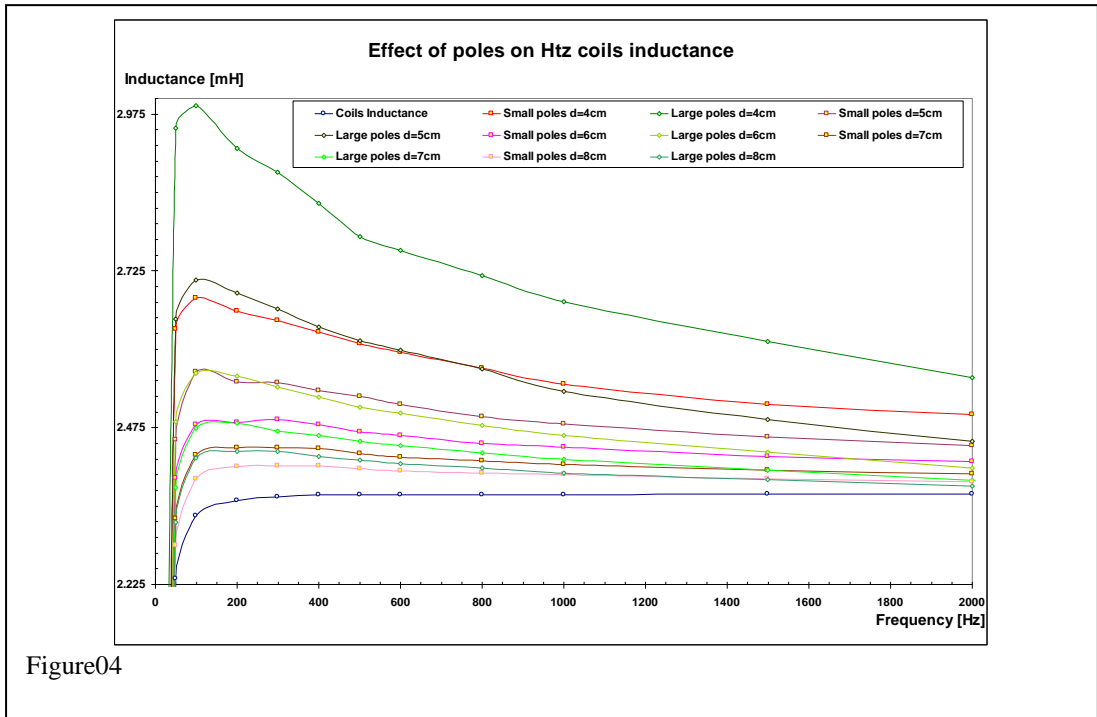

Figure04

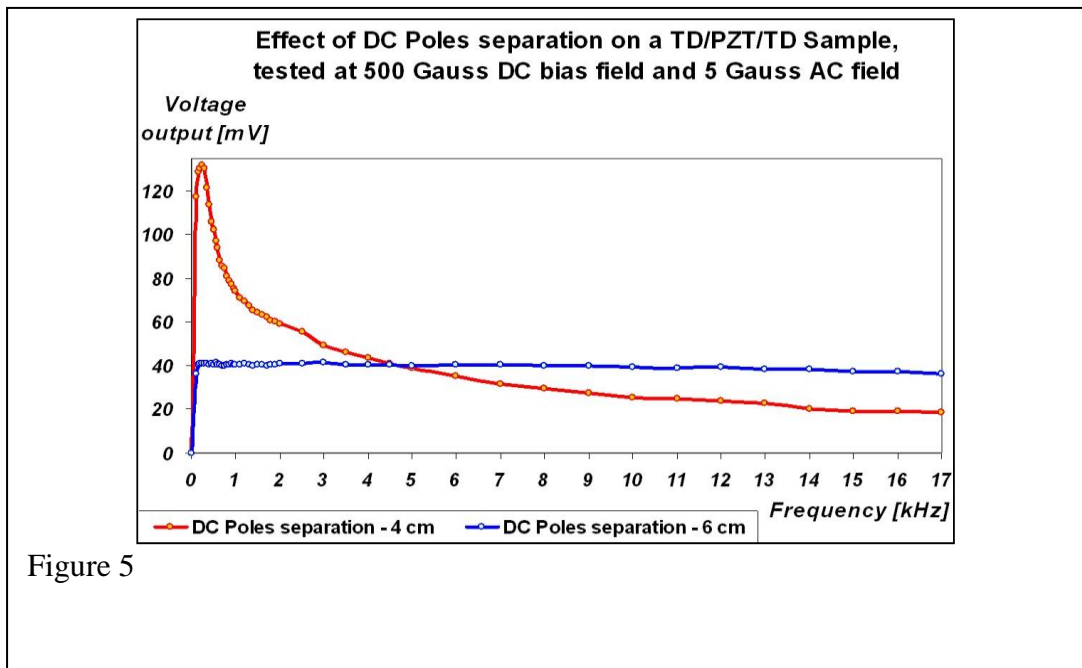

Figure 5

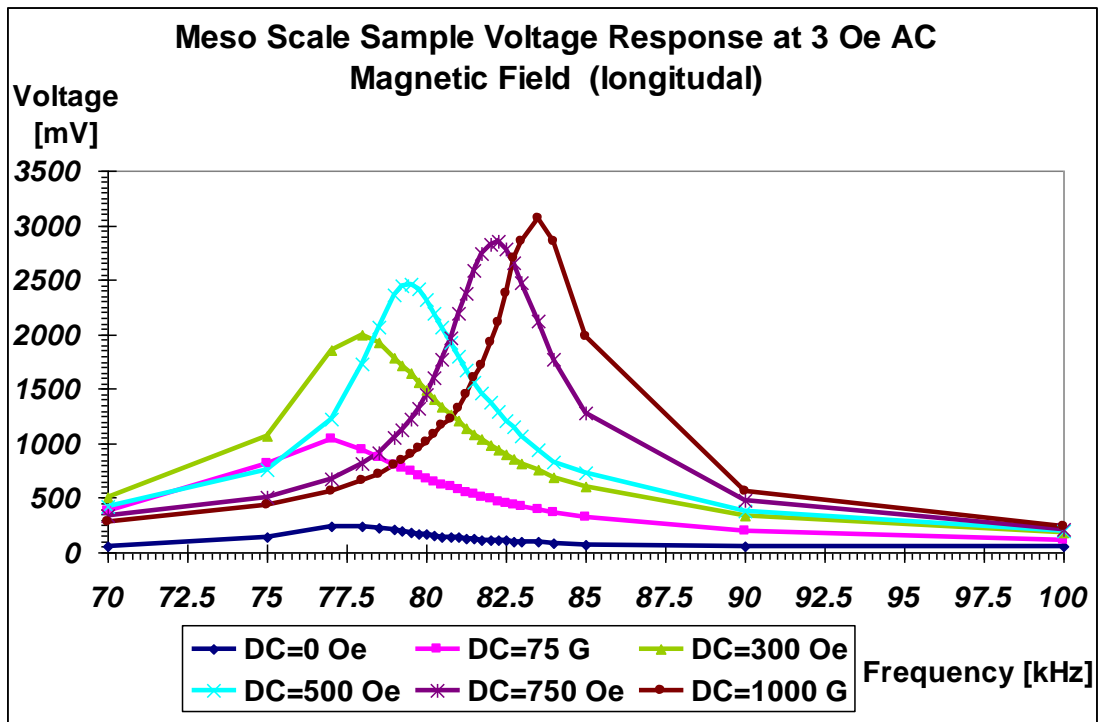

Figure 6 Magnetolectric output for a 3 Oe drive field with difference DC bias field.

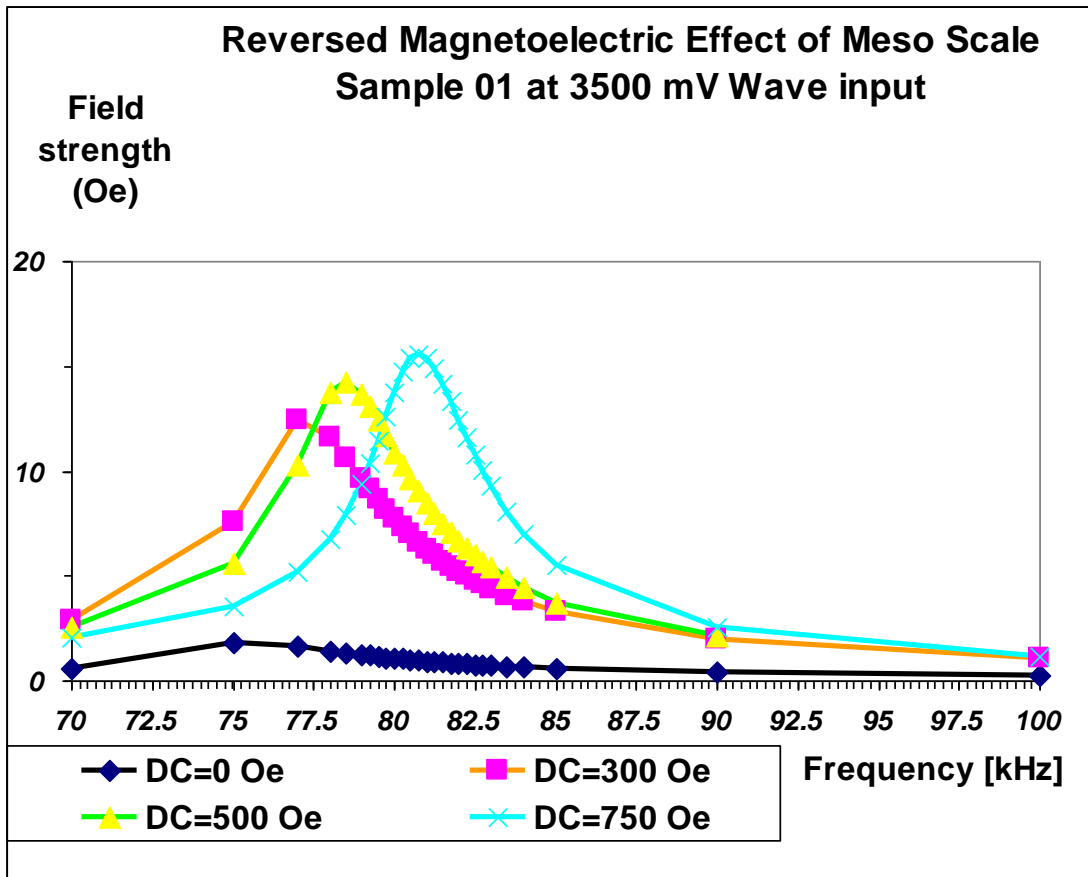

Figure 7 Converse ME measurements the for bias fields 0 – 750Oe . For the sample PZ thickness of 127um gives a converse coeff of 55 Oe cm/KV

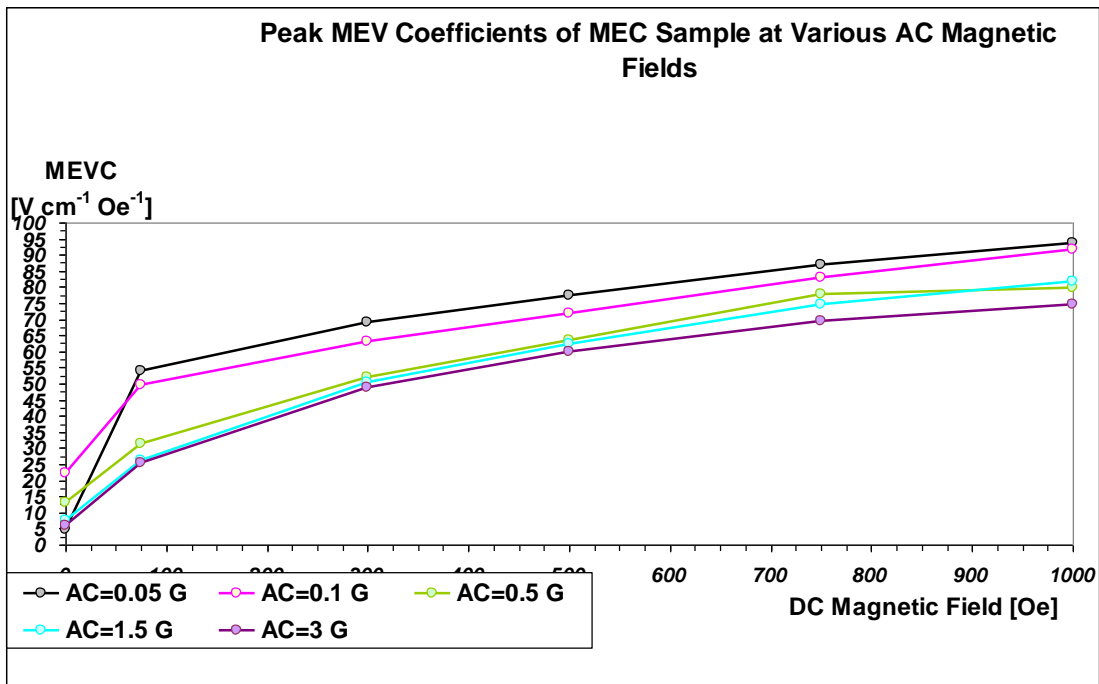

Figure 8 Peak ME coefficients vs DC bias field for different AC drive fields

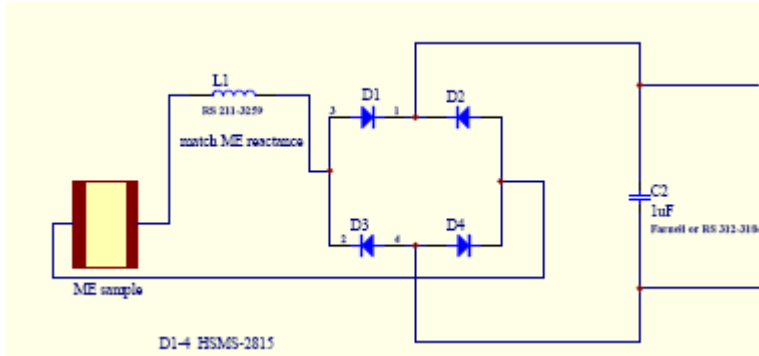

Figure 9a ME micro-power generator, Inductance L1 tunes out the capacitance of the PZ phase.

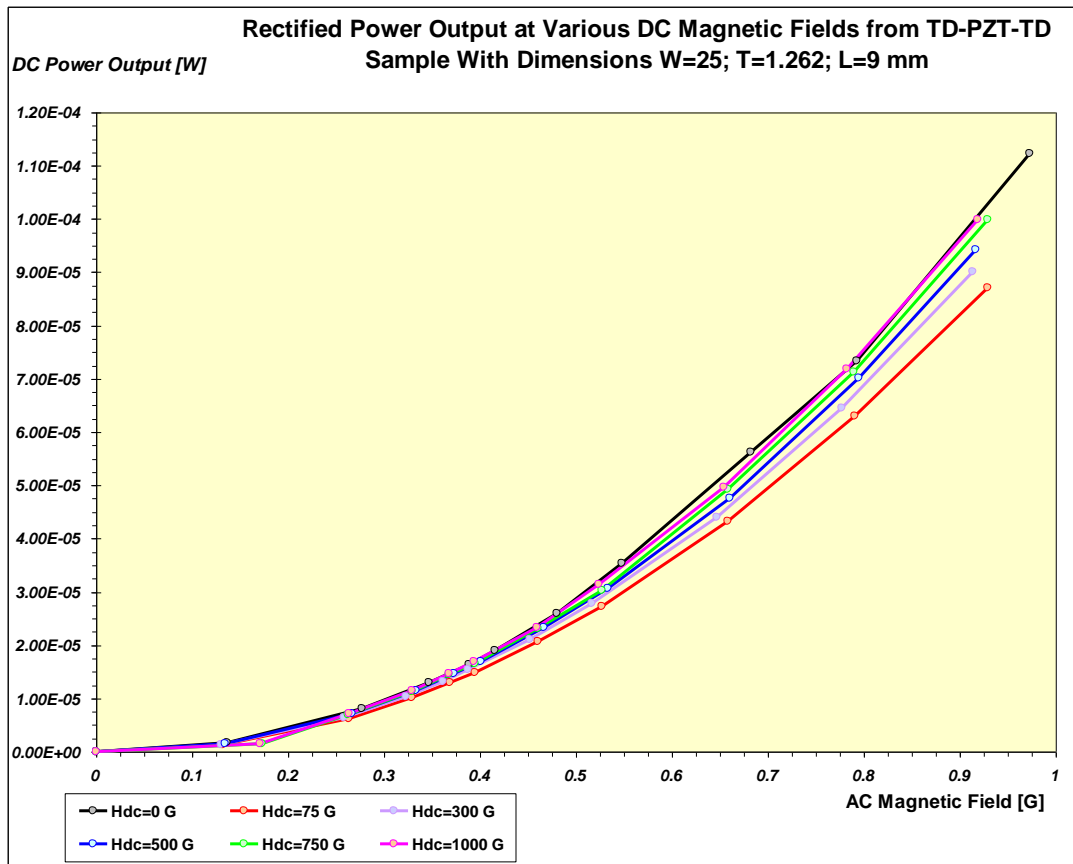

Figure 9b output power in watts for Trialayer sample resonated at 125kHz

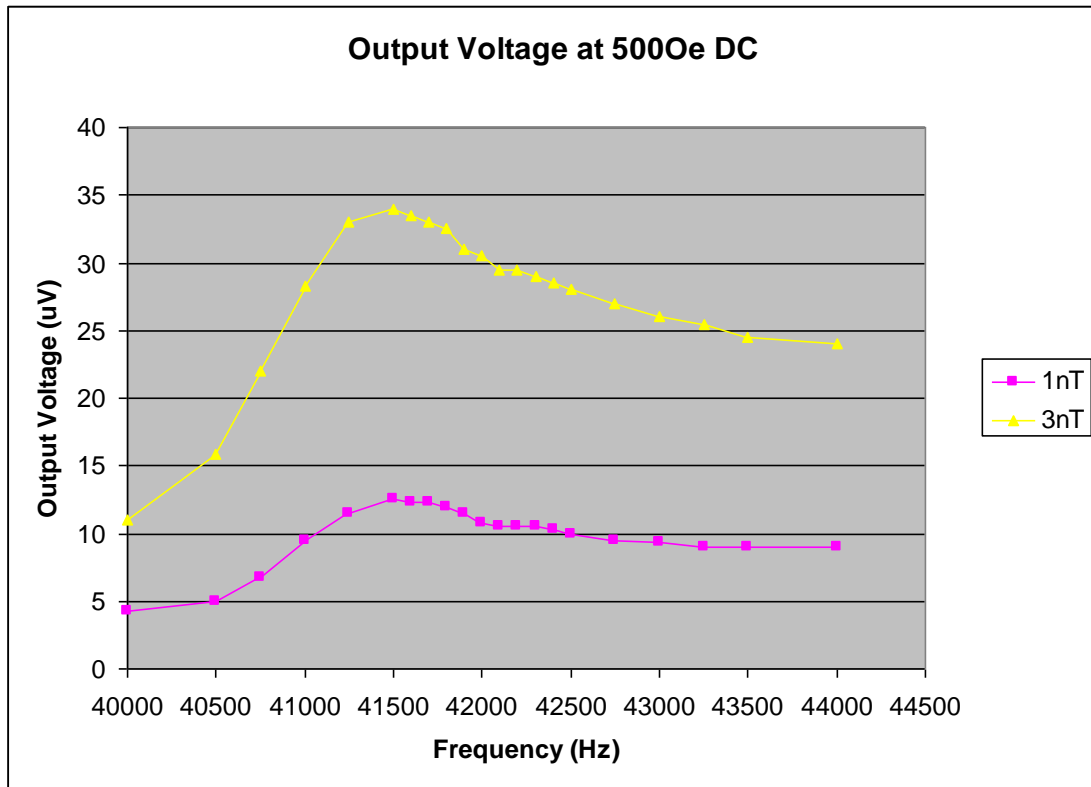

Figure10 – ME sample output vs frequency for 2 applied ac fields at 500 Oe bias field. This sample had a resonant frequency of 41.5kHz and consisted of a trilayer arranged :PZ TD PZ