

CRANFIELD UNIVERSITY

ANDREW CHAN

THE USE OF LOW COST VIRTUAL REALITY AND  
DIGITAL TECHNOLOGY TO AID FORENSIC SCENE  
INTERPRETATION AND RECORDING

DEPARTMENT OF MATERIALS AND MEDICAL  
SCIENCES

PhD THESIS

CRANFIELD UNIVERSITY

DEPARTMENT OF MATERIALS AND MEDICAL SCIENCES

PhD THESIS

Academic Year 2004 - 2005

Andrew Chan

**The Use of Low Cost Virtual Reality and Digital  
Technology to Aid Forensic Scene Interpretation and  
Recording**

Supervisor : Dr D.W Lane

October 2005

© Cranfield University 2005. All rights reserved. No part of this publication may be reproduced without the written permission of the copyright owner.

## **ABSTRACT**

Crime scenes are often short lived and the opportunities must not be lost in acquiring sufficient information before the scene is disturbed. With the growth in information technology (IT) in many other scientific fields, there are also substantial opportunities for IT in the area of forensic science. The thesis sought to explore means by which IT can assist and benefit the ways that forensic information can be illustrated and elucidated in a logical manner. The central research hypothesis considers that through the utilisation of low cost IT, the visual presentation of information will be of significant benefit to forensic science in particular for the recoding of crime scenes and its presentation in court.

The research hypothesis was addressed by first exploring the current crime scene documentation techniques; their strengths and weaknesses, giving indication to the possible niche that technology could occupy within forensic science. The underlying principles of panoramic technology were examined, highlighting its ability to express spatial information efficiently. Through literature review and case studies, the current status of the technology within the forensic community and courtrooms was also explored to gauge its possible acceptance as a forensic tool.

This led to the construction of a low cost semi-automated imaging system capable of capturing the necessary images for the formation of a panorama. This provides the ability to pan around; effectively placing the viewer at the crime scene. Evaluation and analysis involving forensic personnel was performed to assess the capabilities and effectiveness of the imaging system as a forensic tool. The imaging system was found to enhance the repertoire of techniques available for crime scene documentation; possessing sufficient capabilities and benefits to warrant its use within the area of forensics, thereby supporting the central hypothesis.

## TABLE OF CONTENTS

Titles	i
Abstract	ii
Contents	iii
List of Figures	ix
List of Tables	xii
Acknowledgements	xiii
Preface	xiv

### **Chapter 1: INTRODUCTION**

1.1	Introduction	1
1.2	Project Background	2
1.3	Areas of Contribution	3
	1.3.1 Forensic Illustrations	3
	1.3.2 Virtual Reality	4
1.4	Thesis Structure	4
1.5	Summary	5

### **Chapter 2: RESEARCH OBJECTIVE AND APPROACH**

2.1	Introduction	6
2.2	Aim	6
2.3	Research Hypothesis	6
2.4	Fundamental Research Questions	6
	2.4.1 Requirements of the System	7
	2.4.2 Points of Concerns	8
2.5	Research Objectives	8
2.6	Developmental Approach	9
2.7	Summary	10

## **Chapter 3: LITERATURE REVIEW**

3.1	Introduction	11
3.2	Crime Scene Documentation	11
3.2.1	Notes	12
3.2.2	Photography	13
3.2.3	Sketches	15
3.3	Digital Photography	16
3.3.1	Nature of Digital Photography	17
3.3.1.1	Definition	17
3.3.1.2	The Basics	17
3.3.1.3	The Digital Sensor	18
3.3.2	Film Versus Digital Photography	19
3.4	Virtual Environments	20
3.4.1	Various Approach of Virtual Environments	21
3.4.2	Panorama	24
3.4.2.1	Cylindrical	24
3.4.2.2	Spherical	24
3.4.2.3	Cubic	25
3.4.3	Hardware	26
3.4.3.1	Standard Cameras (Single-Row)	26
3.4.3.2	Multi-Row	28
3.4.3.3	Video Camera	30
3.4.3.4	Panoramic Camera	30
3.4.3.5	One Shot Solutions	31
3.4.4	Stitching Software	32
3.4.5	Displaying of the Panorama	33
3.4.6	Virtual Tour	35
3.4.7	Current Areas of Use	35
3.5	Visual Aids	36
3.5.1	Types of Visual Aids	37
3.5.2	Computer Generated Displays and the Courtroom	37
3.5.2.1	USA	39

3.5.2.2	UK	40
3.5.2.3	Persuasive Impact of Computer Images	42
3.5.2.4	Manipulation or Enhancement	45
3.6	Admissibility of Computer-Generated Evidence in the Courtroom	47
3.6.1	USA	48
3.6.1.1	Admissibility of Demonstrative Evidence	48
3.6.1.2	Admissibility of Substantive Evidence	49
3.6.1.2.1	The Frye Test	49
3.6.1.2.2	Federal Rules of Evidence	50
3.6.2	UK	51
3.6.2.1	Civil Legislation	51
3.6.2.2	Criminal Legislation	52
3.7	Standard Operating procedures	54
3.7.1	Preparation	55
3.7.2	Capture	56
3.7.3	Protection	57
3.7.4	Use	57
3.8	Technology in the Courtroom	58
3.9	IBVR and Forensic Science	59
3.10	Summary	60

## **Chapter 4: CASE STUDIES**

4.1	Introduction	61
4.2	Case Study 1	61
4.2.1	The Case	62
4.2.2	Requirements of the Case	63
4.2.3	Presentation	63
4.2.4	The Trial	66
4.2.5	Conclusion	67
4.3	Case Study 2	67
4.3.1	The Case	68
4.3.2	Requirements of the Case	68

4.3.3	Presentation	70
4.3.4	The Trial	71
4.3.5	Conclusion	73
4.4	Case Study 3	73
4.4.1	The Case	73
4.4.2	Requirement of the Case	73
4.4.3	Presentation	74
4.4.4	The Trial	76
4.4.5	Conclusion	76
4.5	Case Study 4	77
4.5.1	The Case	77
4.5.2	Requirement of the Case	77
4.5.3	Presentation	78
4.5.4	The Trial	82
4.5.5	Conclusion	82
4.6	Historical Development	82
4.7	Summary	83

## **Chapter 5: PROTOTYPE**

5.1	Introduction	84
5.2	System Architecture	84
5.3	Requirements of the system	85
5.4	Hardware	87
5.4.1	Camera	87
5.4.1.1	Field of View	88
5.4.1.2	Resolution	90
5.4.1.2.1	Focus	91
5.4.1.2.2	Focal Length	92
5.4.1.2.3	Johnson's Criteria	92
5.4.1.3	Graphic Format	96
5.4.2	The Stage	97
5.4.2.1	Tripod	98

5.4.2.2	Panoramic Head	99
5.4.2.2.1	Nodal Point	101
5.4.2.3	Stepper Motors	102
5.4.2.4	Platform	105
5.5	Software Interface	106
5.5.1	Motor Control	106
5.5.2	Camera Control	109
5.5.3	User Interface	111
5.5.4	Tutorial	118
5.5.5	Software Installation	118
5.6	Summary	118

## **Chapter 6: APPLICATION CASE-STUDY**

6.1	Introduction	119
6.2	Trial of Imaging System	119
6.3	Evaluation Approach	123
6.4	Analysis of Results	125
6.5	Refinement	135
6.6	Summary	140

## **Chapter 7: DISCUSSION**

7.1	Introduction	141
7.2	Current Forensic Tools	141
7.3	Digital Presentation	143
7.4	Imaging System	144
7.4.1	Construction of the Proposed Imaging System	144
7.4.1.1	Camera	145
7.4.1.2	Stage	146
7.4.1.3	Software	147
7.4.2	Evaluation	148
7.4.2.1	Information	149
7.4.2.2	Usability	149



7.5	Applications in Forensic Science and Law Enforcement	151
7.6	Project Analysis	153
7.6.1	Strengths	154
7.6.2	Weaknesses	154
7.7	Summary	155

## **Chapter 8: CONCLUSIONS**

8.1	Introduction	156
8.2	Accomplishment of Objectives	156
8.2.1	Develop a Background Understanding of the Core Subject	156
8.2.2	Identification of the Current Issues Surrounding the Core Subject	157
8.2.3	Investigation of Case Studies	159
8.2.4	Development of a Prototype	159
8.2.5	Evaluation of Prototype	160
8.3	Accomplishment of Central Hypotheses	163
8.4	Recommendations for Future Work	163
8.5	Summary	164

<b>GLOSSARY OF ABBREVIATIONS</b>	165
----------------------------------	-----

<b>REFERENCES</b>	167
-------------------	-----

<b>APPENDICES</b>	
-------------------	--

## LIST OF FIGURES

<b>Figure 3.1</b> – Four Corner Approach.	15
<b>Figure 3.2</b> – An example of the CCD Format compared to its Equivalent Vidicon Tube.	18
<b>Figure 3.3</b> – 3D CAD Model.	21
<b>Figure 3.4</b> – Cylindrical Projections.	24
<b>Figure 3.5</b> – Spherical Projections.	25
<b>Figure 3.6</b> – Cubic Projections.	25
<b>Figure 3.7</b> – Standard Camera (Single-Row) Technique.	26
<b>Figure 3.8</b> – Multi-row Technique.	28
<b>Figure 3.9</b> – FOX System.	29
<b>Figure 3.10</b> – PixOrb Panoramic System.	29
<b>Figure 3.11</b> – Spheron Camera.	31
<b>Figure 3.12</b> – Portal S1 and Cyclovision Parashot One Shot Solutions.	31
<b>Figure 3.13</b> – QTVR Structure.	33
<b>Figure 3.14</b> – QTVR User Interface.	34
<b>Figure 3.15</b> – Recommended Steps for Standard Operating Procedures.	55
<b>Figure 3.16</b> – Defining Stages of Image Transfer.	57
<b>Figure 4.1</b> – Photographs of the Suspect’s Clothing.	62
<b>Figure 4.2</b> – Transfer of Fibres from Suspect to Victim and Vice Versa.	64
<b>Figure 4.3</b> – Transfer of Red and Black Fibres onto the Deceased.	65
<b>Figure 4.4</b> – Representation of Individual Red Fibre Transfer on Scene Photographs.	65
<b>Figure 4.5</b> – Illustration of Tapings through Activation of Hotspots.	66
<b>Figure 4.6</b> – Original Presentation Illustrating Shoeprint Evidence.	69
<b>Figure 4.7</b> – Capture Process to Create QTVR Movie.	70
<b>Figure 4.8</b> – Key Areas of the Presentation.	71
<b>Figure 4.9</b> – Compiled Images of the CG Presentation as Part of the Jury Pack.	72
<b>Figure 4.10</b> – Screenshot Showing the Three Sections of the CG Presentation.	75
<b>Figure 4.11</b> – Activation of Hotspots to Remove Layers in the Scene Revealing Underlying Evidence.	75

<b>Figure 4.12</b> – Overall Transfer of Fibres	78
<b>Figure 4.13</b> – Overall Distribution of Fibres.	79
<b>Figure 4.14</b> – Detailed Distribution of Fibres.	80
<b>Figure 4.15</b> – Scanned Images of Tapings Taken from the Deceased.	81
<b>Figure 4.16</b> – Display of Scene Photographs.	81
<b>Figure 5.1</b> – Three Components of the Imaging System.	84
<b>Figure 5.2</b> – Requirements of the Imaging System.	87
<b>Figure 5.3</b> – FOV of Camera’s Lens	88
<b>Figure 5.4</b> – Orientation of Camera.	89
<b>Figure 5.5</b> – Relationship of FOV and Camera’s Dimensions	90
<b>Figure 5.6</b> – Area of Focus.	91
<b>Figure 5.7</b> – Three Levels of Discrimination of the Johnson’s Criteria.	93
<b>Figure 5.8</b> – Representation of 1 Cycle.	93
<b>Figure 5.9</b> – Requirements of Each Level of Discrimination.	94
<b>Figure 5.10</b> – Process involved in Capturing JPEG, TIFF and RAW files	97
<b>Figure 5.11</b> – Components of the Stage.	98
<b>Figure 5.12</b> – Adjustment of Height of System.	99
<b>Figure 5.13</b> – Restricted Rotation of Panoramic Head.	99
<b>Figure 5.14</b> – Missing Area of Scene as a Resulted of Restricted Rotation.	100
<b>Figure 5.15</b> – Attachment of Camera to the Panoramic Head.	101
<b>Figure 5.16</b> – Panoramic Head and Adjustment of Nodal Point.	101
<b>Figure 5.17</b> – Two Degrees of Rotation of the System.	102
<b>Figure 5.18</b> – Essential Components to control Stepper Motors.	103
<b>Figure 5.19</b> – Illustration of Circuit Box Connections.	104
<b>Figure 5.20</b> – Position and Attachment of Platform.	106
<b>Figure 5.21</b> – Access to Various Stages through Tabs.	111
<b>Figure 5.22</b> – Front End of Software Interface.	112
<b>Figure 5.23</b> – ‘Start’ Stage of the Capture Process.	113
<b>Figure 5.24</b> – Percentage Overlap Stage.	114
<b>Figure 5.25</b> – Positioning of Camera.	115
<b>Figure 5.26</b> – ‘Vertical Settings’ Stage.	116
<b>Figure 5.27</b> – ‘Capture’ Stage.	116

<b>Figure 5.28</b> – ‘Develop’ Stage.	117
<b>Figure 6.1</b> – Limited VFOV of a Cylindrical Panorama.	122
<b>Figure 6.2</b> – Blurring of the Resultant Panorama.	123
<b>Figure 6.3</b> – Colour Coding of Connectors and Socket.	136
<b>Figure 6.4</b> – Replacement of the Cables.	137
<b>Figure 6.5</b> – Outline Demonstrating Position of Camera.	138
<b>Figure 6.6</b> – Front End of User Interface.	139
<b>Figure 6.7</b> – ‘Setting’s Stage.	139

## **LIST OF TABLES**

<b>Table 3.1</b> – Dimensions of Several CCD Formats.	19
<b>Table 3.2</b> – Comparison of the Two Classes of VE Techniques.	23
<b>Table 5.1</b> – FOV of the Canon PowerShot G3.	90
<b>Table 5.2</b> – Description of each Level of Discrimination.	93
<b>Table 5.3</b> – Johnson’s Criteria for the Canon PowerShot G3 at 2m Range	95
<b>Table 5.4</b> – Number of Columns and Rows for Varying Percentage Overlap	108
<b>Table 5.5</b> – Features Incorporated into Software Camera Controls.	110
<b>Table 5.6</b> – Commands responsible for the Features of the Camera.	110
<b>Table 5.7</b> – Predefined Settings for Quick Start Mode.	113
<b>Table 6.1</b> – Volunteers of the Evaluation.	125

## **ACKNOWLEDGEMENTS**

Many thanks to all those people who have been involved throughout the term of this research, without them this PhD would not have been possible. Particular thanks to the following:

- Dr David Lane, my supervisor who has provided me with advice, assistance, direction and inspiration during the course of my research.
  
- Members of staff at Cranfield University Defence College of Management and Technology, including Dr Mike Cousin for his expertise in the area of computer programming, Mike Selwood for his assistance in construction and Donald Peach for his guidance.
  
- Pam Hamer and all members of staff at Forensic Alliance, the sponsor of this project in collaboration with the Department of Material and Medical Science at Cranfield University for their cooperation and commitment to this project.
  
- Special thanks to my friends and family especially my girlfriend Ann Yau for their patience, constant encouragement and faith.

*The whole is more than the sum of its parts.*

*Aristotle*

## PREFACE

The thesis aims to present an in-depth study into the use of digital and computer-generated techniques within the forensic environment. In order to provide a comprehensive understanding of the issues on discussion, a supplementary CD will provide examples of the work in support of the thesis. Additional software plug-ins which may be required for correct viewing of the examples is included in the CD. References to the supplementary CD are denoted by the CD1 icon within the thesis. Insertion of the CD will auto load the main page where examples are sorted by the relative chapters and subsections in which they appear in the thesis.



*References to the CD are indicated by the CD1 icon.*

The project's resultant system software is on a second CD accompanying the thesis and is denoted by the CD2 icon within the thesis.



**System Software**

## **Chapter 1: INTRODUCTION**

### **1.1 Introduction**

Forensic science has become an increasingly difficult discipline in today's society. This is due partly to the increase in forensic related television shows which are bringing awareness of the forensic capability to criminals. In response to the escalating threat, forensic science must continue improving its repertoire of techniques to counter criminal activities and improve on the reliability of existing methods. The manner that we operate certain tasks in everyday society has no doubt been influenced by the presence of information technology (IT); the forensic communities are no exception. With the rapid growth in IT in other scientific fields, there are also substantial opportunities for IT in the area of forensic science. In order to gauge the potential, the question must be asked to 'How can professionals take advantage of these benefits without compromising their work?'

Although digital imaging technologies have been used in a variety of scientific fields for decades, their application in the criminal justice system has been relatively recent [SWGIT, 2001]. The computer, as a visual medium offers a substantial number and variety of facilities for the production, manipulation and presentation of visual imagery, which presents new perspectives and techniques for its application in forensic science. The exploitation of computers as a tool for presentation of images in the courtroom opens up opportunities for the communications of information in an innovative, yet increasing familiar manner as a result of television and home computers.

Traditionally law enforcement agencies have relied on the three basic methods of documenting a crime scene: sketches, film photography and written notes. Accurate recording of crime scenes in their original state is essential for both subsequent investigation and presentation in court, which relies on the accuracy and comprehension of these records. Tying together these records in a logical manner requires expert administration and immense concentration from those viewing the evidence. These are exacerbated when the crime scene needs to be 'revisited' weeks, months or even years later.



It is of paramount importance that the jury and all personnel involved in the investigation understands as fully as possible all aspects of the crime scene. Although traditional techniques of crime scene documentation cannot be replaced, they may not necessarily form the best method to record and illustrate the crime scene. “I think what the police service lacks at the moment are the systems for documenting, recording and assessing evidence found in the open air which can show the relationships between pieces of evidence,” says Detective Superintendent Newman, of Avon and Somerset Constabulary [Adams, 1998].

In three dimensional (3D) worlds, we continue to record and analyse using two dimensional (2D) visual documents of sketches and photographs. These techniques are effective and widely accepted, although they are not without its drawbacks. Current documentation techniques greatly restrict the actual visualisation of the incident, requiring a careful cross referencing of the details in order to understand it. With the use of various technologies, it is possible to deceive the eyes into a 3D perception. This has the potential to allow for more efficient observation of a crime scene and ultimately provide an invaluable tool in the process of crime scene documentation.

Application of novel technology in the forensic community warrants careful consideration. Prior to the acceptance of such technology, they face the questions of reliability of the technology and acceptance within court. Without such deliberation, such novel technology may prove to be worthless regardless of the potential benefits that it may bring.

## **1.2 Project Background**

The project has stemmed from advances in digital imaging and the need for greater flexibility in the area of crime scene documentation; taking into consideration the current laws regarding admissibility of evidence.

Several projects by students on the Cranfield University MSc in Forensic Engineering and Science have illustrated potential advances in the application of digital imaging in

forensic science [Chan, 2002] [Garnier, 2002]. These have provided awareness of the potential benefits and applications of such studies to the commercial industry.

Part funded by Forensic Alliance (FA) which is now a part of LGC, this project forms the first PhD collaboration with Cranfield University. Liaison with FA was led by Ms Pam Hamer; head of Research and Development at FA who has over thirty years experience as a forensic scientist. Supervisor to the project was Dr David Lane; a senior lecturer in the Cranfield University Centre for Materials Science and Engineering, and the Chairman of the University's MSc in Forensic Engineering and Science.

### **1.3 Areas of Contribution**

Throughout the course of the research presented in the thesis, contributions have been made to several different fields of knowledge. The following sub-sections (1.3.1-1.3.2) addresses the contributions that the thesis makes. These are derived from exploring the concept of various imaging and computer-generated (CG) techniques and their impact within the field of forensic science.

#### **1.3.1 Forensic Illustrations**

The application of CG illustrations in forensic science is relatively recent and its development has been rapid. This thesis makes the following contributes to the knowledge of forensic illustrations:

- The integration of widely available commercial off-the-shelf components into a single digital panoramic camera system to provide a low cost solution in the documentation of crime scenes.
- Application of virtual environments (VE) in the forensic community at any specific stage of an investigation. Benefits of such tools extend far beyond the initial onset of an investigation. Particular benefit of the communicative nature of the system can be seen in its application not only throughout the investigation but also in the courtroom.
- Although in the United Kingdom (UK), the application of digital images in court is relatively new, its use in the United States (US) is more established.

The thesis provides a study of the admissibility of digital images and CG evidence in the courtroom within the UK and US, and the difficulties that have arisen as a result of its use. This will aid a smoother transition in the use of digital images as an alternative to more traditional film-based images.

### **1.3.2 Virtual Reality**

The thesis makes the following contributions to the area of virtual reality (VR):

- Exploration of different techniques for the creation of VR has provided a useful insight into its application and potential in the forensic community.
- The cost required for the creation of a VR is typically out of reach of all, but the most high profile cases. By using varied VR techniques, it has enabled the creation of low cost VEs which are accessible to any cases from petty crime to homicides.

### **1.4 Thesis Structure**

This section outlines the structure of the remaining chapters by providing a brief description of the intended contents of the thesis. This is as follows:

- Chapter 2 presents the general aim, hypothesis and approach of the thesis. The fundamental research questions posed in this chapter aim to develop and drive the research forward.
- Chapter 3 describes the theory upon which the main body of work is based, and explores the established principles within the forensic and IT communities. It also presents research that has been conducted in this area and addresses the principles and approaches that have been tried and tested; taking into consideration the outcome of such an approach.
- Chapter 4 presents a number of case studies that have been carried out during the course of the research and that have involved the use of digital imaging and CG techniques. It addresses key issues relating to actual requirements from the forensic and law enforcement communities regarding submission of digital presentation in court. †

- Chapter 5 describes the approach to the development of a prototype imaging system and explores the parameters of the individual components that comprise the resultant system.
- Chapter 6 presents the evaluation of the prototype. It addresses its usability and scrutinises the capability of the system. It describes the views of the potential users and the impact that the prototype imaging system may have on their work.
- Chapter 7 discusses the results of the research. It presents a discussion on a number of areas covered within the thesis and presents a detailed account on the prototype imaging system.
- Chapter 8 presents the conclusion from the research by drawing upon the research results and discussions. This chapter also discusses the achievements of this work based upon the original aims and objectives that were established. Suggestions for future work are also presented in this chapter.

## 1.5 Summary

This chapter has laid the foundation for the thesis. It has introduced the thesis through a forensic context and provided justification for the research. A description of the background of the project has been outlined and the specific contribution that the thesis makes to various fields. Finally, the chapter presented an outline of the structure of the thesis to provide an overview of what is to follow. Beginning with the aim of the project, the thesis now provides a detailed description of the research by formulating the objective of the project, and the intended approach.

† Coyle, T., Larkin, A., Smith, K., Chan, A., Hunt, N. (2004). *Fibre Mapping – A Case Study*. Science & Justice. Volume 44 Number 3. Pages 179-186.



## **Chapter 2: RESEARCH OBJECTIVE AND APPROACH**

### **2.1 Introduction**

This chapter presents the broad aim of the project and lays the foundation for the main research. It allows for the formulation of the project's main objectives and brings up fundamental research questions that need to be explored. The chapter also identifies the research approach taken in order to address and achieve the aim and objectives.

### **2.2 Aim**

The broad aim of this research project is to explore the use of modern technologies in an attempt to develop a viable forensic tool for the recording of crimes scenes. It is envisaged that such novel system would deliver a high quality and cost effective technique to create accurate records of crimes scenes, whilst still in their original untouched state.

### **2.3 Research Hypothesis**

Based on the broad aim of the research project outlined above, the following hypothesis was postulated:

“Through the utilisation of low cost IT, the visual presentation of information will be of significant benefit to forensic science in particular for the recording of evidence and its presentation in court. If a scene could be captured in such a way that offers the viewer the ability to move freely, as if he or she were present at the actual scene, it would be advantageous at various stages of an investigation from the initial crime scene to the courtroom”.

### **2.4 Fundamental Research Questions**

In order to drive the research forward, numerous discussions took place with the staff at FA regarding the needs, requirement and concerns about the development of the proposed imaging system. In order to provide a viable system capable of forensic

application, the following fundamental research questions were posed to aid the development and refinement of the research objectives.

#### **2.4.1 Requirements of the System**

The intended end users of the system are the forensic scientist and scenes of crime officers (SOCOs). It is beneficial to encompass as much of their requirements as possible. Meetings with the staff of FA helped establish the following requirements of the system:

- **Low Cost** – Law enforcement agencies already face cost limitations therefore; the need to employ a low cost solution for delivering an imaging system for recording a crime scene is paramount.
- **Ease of Use** – The technological knowledge of users are often diverse; the ability to operate complex equipment can deter the user from implementing the system. Ease of use of the system is an essential requirement and should enable any user of any ability to operate with little difficulty.
- **Portability** – Portability of the system is an important issue due to its intended use in remote locations. Consideration must be given to the weight and compactness of the system.
- **Durability** – Knocks and bump often accompany the transit and operation of the system which will have a direct impact on the reliability of the system. The need for a durable system will ensure that the equipment is reliable and able to perform its function.
- **Time** – A crime scene in its original untouched state is often short lived. A system is required that captures the required images as quickly as possible and does not prolong the process of documentation further.
- **Quality** – The quality of the output images is an important consideration. Low quality images will provide little use as a recording tool. Consideration must be given when deciding on the appropriate hardware.

### **2.4.2 Points of Concerns**

In addition to the system requirements, personnel at FA raised several points of concern that related to the user confidence in the proposed system:

- Low cost solutions are always perceived as being inferior to a more expensive equivalent. Although this may sometimes be true, the accuracy to which it depicts the crime scene and whether this is of sufficient quality is more important, and this may not be related to cost.
- Reliability of the system is an important issue and the deployment of the system must result in the performance as intended.
- In specialised professions such as forensic science and law enforcement, creditability of the system will play an influential part in establishing its successful deployment. The ability to tamper with the resultant images should be carefully investigated and measures taken to avoid any bias in the imaging system.
- The potential of the imaging system to be used not only for subsequent investigation but also application in the courtroom as a method of communicating the layout of the scene to the jury is a significant advantage. Therefore, the admissibility of graphical presentation in court is an important issue, and must be carefully examined to bring awareness of possible problems that may be faced.

### **2.5 Research Objectives**

In order to derive the research objectives of the thesis, it was necessary to inspect and consider the core aim of the thesis and the research hypothesis. In addition, careful consideration was given to the requirements of the sponsor and the points of concerns that were made aware in section (2.4). These led to the identification of a number of specific research objectives that would need to be addressed, as follows:

- (i). **Develop a background understanding of the core subject** – There is a necessity to gain an extensive understanding of the fundamental crime scene documentation techniques that are currently being implemented by the law

enforcement communities which will illustrate their associated strengths and weaknesses. In addition, understanding the basic digital imaging concepts and the broad area of VEs will be beneficial to the requirements in the development of a prototype imaging system.

- (ii). **Identification of the current issues surrounding the core subject** – There would be a need to explore current issues surrounding the use of digital imaging, VEs and CG evidence in a forensic context. This will allow us to gauge the possible acceptance and implementation of such technology.
- (iii). **Investigation of case studies** – Use of case studies from genuine crime scenes cases would be performed in collaboration with FA, in order to assess the potential of CG illustrations and digital images in the courtroom. This evaluation would provide first hand experience on the general perception of digital imaging and CG evidence in today's courts and within the forensic community.
- (iv). **Develop a prototype** – A semi-automated imaging system should be developed and constructed which captures digital images for the creation of virtual records of crime scenes using complete panoramas with the ability to view and rotate within the scene. Recording the scene in this way would provide a permanent and robust recording in support of traditional crime scene documentation techniques. This would also aid in the assessment of various scenarios during subsequent investigation.
- (v). **Perform an evaluation** – An evaluation of the developed prototype would be performed with the intended end users of the system. This aims to assess the adequacy of such system for its intended purposes. Assessment would be based on the importance of capabilities in forensic science and how well this was realised by the technology.

## **2.6 Developmental Approach**

In order to achieve the research objectives (IV) and (V) set out, the developmental approach will be detailed to provide a guideline by which the construction of the imaging system will progress. This will be divided into several stages of development,



encompassing investigation of the technology and its parameters. These stages of development include: the camera, stage and software.

- 1) **Camera** – The quality of the digital camera implemented within the system has a direct affect on the overall quality of the generated panorama. It is important that the correct digital camera is selected based on the requirements of the system. In addition, the limits of the digital camera in terms of the field of view and visual detail should be determined in order to identify the capabilities of the system.
- 2) **The Stage** – The purpose of the stage is to provide a platform which encompasses all the components of the system including the digital camera. It will accommodate stepper motors which are intended to provide the necessary rotation of the digital camera for image capture.
- 3) **Software** – Through the use of computer programming, it is the role of the software to combine the ability to control the camera's capture process and rotation of the stepper motors into a central user interface.

The final part of the research is concerned with devising and executing a trial using the prototype imaging system with user-group representatives in order to establish the achievement of the aim and objectives. The empirical results collected from the trial would be evaluated and analysed to determine the general perception of the imaging system and its value as a forensic tool.

## **2.7 Summary**

This chapter has defined the central hypothesis of this thesis, by first introducing the broad aim of the research project. It then posed fundamental research questions from which the main research objectives have been derived. Finally, the chapter has identified the strategy that would be adopted in order to meet these objectives. From this point, the thesis now proceeds to describe the existing intellectual body of knowledge, the theory, which underpins the research.

## **Chapter 3: LITERATURE REVIEW**

### **3.1 Introduction**

This chapter focuses on two areas of research; the existing body of knowledge upon which the main bulk of the research is based and the research that has been conducted in this area.

The first section of this chapter will provide an outline of the fundamental techniques currently employed by law enforcement communities for crime scene documentation. The section then describes the value of digital photography and also provides an in-depth study of virtual environments (VEs) and their methods of construction.

The second section is concerned with the current application of visual presentation within the courtroom. By analysing approaches that have already been used provides a great deal of knowledge that can be applied to the current research and aid in gauging the usefulness of the proposed imaging system as well as its acceptance and transfer to the courtroom. This section will derive from more traditional techniques of visual aids, the benefits of visual presentations. Since the judicial system varies between countries, the issues of CG displays may also differ and will be explored. Focus will be placed on the use of CG within the UK, drawing from the experiences of more established countries such as the US. In particular, discussions on the benefits and detriments of using CG display and evidence in courts will be examined, including the admissibility of such evidence. The ability of courtrooms to accommodate the technology will also be covered.

### **3.2 Crime Scene Documentation**

The goal of a criminal investigation is to assist in establishing the series of events that may have transpired and identify the accountable party. This is achieved through careful documentation of the crime scene and recognizing all relevant physical evidence. “Physical evidence encompasses any and all objects that can establish that a crime has been committed or can provide a link between a crime scene and its victim or a crime and its perpetrator” [Saferstein, 2001]. Crime scene documentation is often the

most time consuming step in an investigation. There is a limited amount of time where a crime scene remains in its untouched state and the opportunity must not be lost in acquiring as much information as possible before the scene is disturbed. These records are important, not only throughout the subsequent investigation but may also be valuable for the purposes of re-evaluation of scenes or ultimately for use in the courtroom.

The principles of crime scene documentation are to record and preserve the condition of the crime scene. This also serves to document the location and relationship of physical evidence within the scene. Crime scene documentation commences at the moment an investigation begins and should take precedent over any examination of the scene. Although no two crime scenes are ever the same, SOCOs will adhere to certain crime scene protocol and procedures in the processing of the scene. This will ensure that the integrity of any evidence recorded is maintained and aid its admissibility in court.

The three main methods for crime scene documentation comprise of notes, photography and sketches. Although individually, these techniques may be inadequate to provide a detailed documentation of the scene; their combined strength provides a complete and detailed account that is required for subsequent analysis of the scene. All three methods should be employed at a scene to ensure completeness of recording.

### **3.2.1 Notes**

SOCO's are faced with an ever increasing need to document the scene as thoroughly as possible. Note taking forms the first of these techniques and perhaps one of the most important stages of crime scene documentation. From the onset of an investigation and throughout the processing of the scene, notes are taken continuously by the SOCO. These will not only be invaluable during the subsequent investigation but may serve as a reminder of the case months, perhaps years later.

A detailed written description of the scene should encompass a complete record of everything observed and accomplished during the investigation. Although, there are no

specified guidelines in the note taking process, there is certain information that should be included in such recording [Lee, 2001]:

- Type of crime.
- Date and time the crime was first reported.
- Identification and details of first reporting officer.
- Details from any witness and other personnel of importance.
- Description of the scene including weather, location and surrounding areas.
- Description of the primary crime scene, including the location and state of any bodies.
- Identification of any physical evidence found at the crime scene.
- Details of crime scene documentation including photographs and sketches.
- Recording details of the evidence processing, collection, packaging, and transportation stage.
- Conclusion of the crime scene investigation should be documented with the date and time.

The extensive list is by no means comprehensive and represents only some of the information that should be included in the note taking process. Note taking can be a slow and laborious activity especially when presented with a scene that may possess numerous pieces of evidence. One such technique to tackle this is with the use of a pocket tape recorder [Fisher, 2000]. This provides a faster medium by which the thoughts and observation of the SOCO can be noted. However, the tape must be transcribed into a written format at some stage.

### **3.2.2 Photography**

Photography is one of the most useful tools in the arsenal of crime scene documentation techniques; by providing a permanent visual record of the scene and its related areas. The saying, “one picture is worth a thousand words” is certainly true in respect to crime scene photography. A photograph provides an accurate depiction of the scene that surpasses any verbal description that an investigator can communicate. The same is true for written reports where Staggs says “Whatever type of crime scene an investigator is

faced with, photographs can communicate more about crime scenes and the appearance of evidence than the written report” [Staggs, 1999].

While photographs provide valuable aid during the subsequent investigation, they are particularly important in communicating the scene to the jury. Very rarely does the jury visit the scene; therefore photographs provide the only opportunity for the scene to be observed.

An important step in photographing a crime scene lies in properly logging each photograph taken. This process is intended to prevent any confusion as to what the photograph is depicting and the location it was taken. These should also include the date and time at which the photograph were taken and the camera setting utilized to capture the photographs.

The most important prerequisite for photographing a crime scene is to have it in an unaltered condition [Saferstein, 2001]. Therefore, before anything is touched and a detailed examination of the crime scene takes place, the crime scene should be photographed. Photographs must be an accurate representation of the crime scene and the evidence [Staggs, 1999]. Poorly captured crime scene photographs can directly affect the success of a crime scene investigation. In order to ensure a complete photographic documentation of the crime scene and its related evidence, a three step approach is normally employed [Staggs, 1999]:

- (i). **Overall photographs.** Overall photographs enable the depiction of the entire scene and allow the visualisation of the scene as the photographer, first saw. When shooting the overall scene, the photographs should show the layout of the crime scene and the overall spatial relationship of the various pieces of evidence to each other [Schiro, Accessed 2006b]. In order to provide a complete coverage of the scene, the four corner approach as illustrated in Figure 3.1 can be utilised.

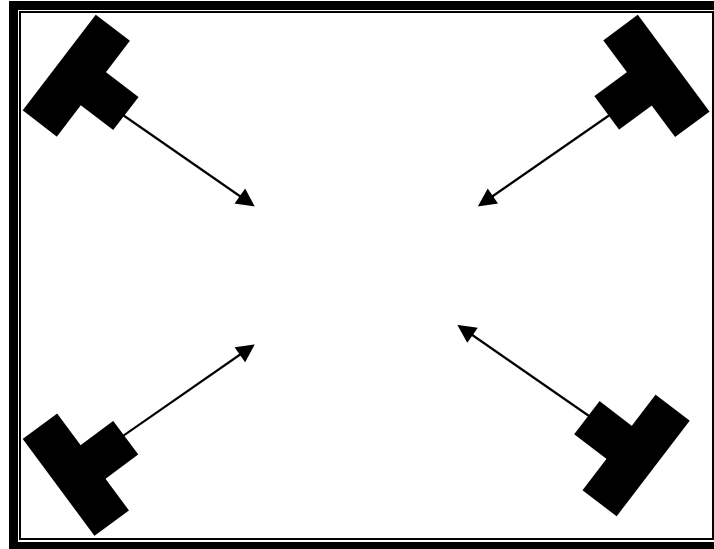

**Figure 3.1** – Four Corner Approach.

- (ii). **Mid-range photographs.** Mid-range photographs further establish the relationship between the evidence and the surrounding structures in the crimes scene.
- (iii). **Close-up photographs.** Close-up photographs are particularly important to capture the details of specific key evidence. It is important to ensure that detailed photographs are taken of the physical evidence in the conditions that they were found prior to their removal. Close-up photographs should follow two steps; a photograph of each specific key evidence followed by the same photograph but with a measuring device placed beside the piece of evidence. This ensures that the present of the measuring device did not in any way alter the scene or conceals any important information. The purpose of close-up photographs is to provide the ability for a direct one-to-one comparison of the items of evidence.

### 3.2.3 Sketches

Sketches forms the final phase in the crime scene documentation process. Sketches have to the ability to depict a scene in its simplest form therefore omitting excessive details which would otherwise complicate the understanding of the scene. For this reason, sketches provide an excellent method for complementing scene photographs; which alone are insufficient to represent the scene.

Sketches have an advantage over photographs as they can accurately depict the spatial relationship of objects in the scene which may appear distorted in photographs due to their 2D representation of 3D objects. The advantages of a crime scene sketch are in providing a permanent record of the actual size, distance and relationship of the crime scene and its physical evidence [Lee, 2001]. These should include the dimension of the scene and show the location of all objects having a bearing on the case [Saferstein, 2001]. There are two basic types of crime scene sketches used as part of a crime scene investigation: a rough sketch and a final sketch [Lee, 2001].

Crime scene sketches commences with a simple rough sketch which entails the representation of all relevant structures in and around the crime scene. With the use of a tape measure, objects in the scene should be located in the sketches by distance measurement from two fixed points, such as the walls of a room [Saferstein, 2001]. The final sketch can be completed at a later date and should be drawn with care, reflecting on the information contained within the rough sketch. The availability of computer programs such as Computer-Aided Design (CAD) allows the process of completing a final sketch to be less labour intensive.

### **3.3 Digital Photography**

The rapid growth in technology is continually changing the ways in which forensic experts operate. These provide an improved and more efficient means for performing their work. Digital photography is one such technology that is rapidly gaining popularity within the field of forensic science; as an additional tool in crime scene documentation procedures.

The relatively novel nature of digital photography in the forensic and law enforcement communities presents numerous concerns regarding its value and credibility. Through considerations of these concerns and a greater understanding of the underlying principles of the technology, the potential acceptance of the proposed imaging system can be gauged. Investigating the following questions regarding digital photography and CG displays through the course of this chapter will provide invaluable information that can be applied to the proposed imaging system:

- What is digital imaging?
- What are the advantages and disadvantages of digital photography compared to traditional photography?
- Are the existing portions of the law that deal with digital recording as evidence adequate for digital images?
- What is the current acceptance of the use of digital images and CG displays in court?
- Are courts adequately equipped to deal with the presentation of computer aided presentations?
- How has the use of digital imaging and CG displays in court developed in the U.K compared to the rest of the world?

### **3.3.1 Nature of Digital Photography**

Digital photography can provide numerous benefits including enhancement in the accuracy and quality of work. However, the nature of digital photography also brings some disadvantages that may possibly impede the outcome of an investigation. The unique quality of digital photography results from its hybrid nature of being part photograph, part computer data.

#### **3.3.1.1 Definition**

What is a digital image? “A digital image (or photograph), as it will be used in the thesis, is a numerical representation of an image recorded simple as a series of binary digits (bits); either one or zero with no values in between” [House of Lords, 1998].

#### **3.3.1.2 The Basics**

The structure of a digital image consists of a very large number of picture elements called pixels, arrayed in some regular pattern. Each pixel is a set of discrete numbers consisting of bits of information representing a specific colour, intensity and location in the array. The number of pixels in an image has a direct bearing on the quality of a digital image in terms of its sharpness and clarity, i.e. the more pixels per inch (ppi) denotes better quality.



### 3.3.1.3 The Digital Sensor

The underlying principles of conventional film photography also holds true for digital photography in terms of the way that light is used to create an image. The difference lie in the image sensor used to capture the image. Instead of using light sensitive film to record an image; most digital cameras use a light sensitive chip called a charged coupled device (CCD) or in some cases complementary metal oxide semiconductor (CMOS) to record the image electronically.

CCD sensors are often referred to using imperial fractions such as 1/1.8" or 1/3". This type of designation follows a set of standard sizes, given to television camera tubes in the 50's. This naming convention was carried over to CCD sensors and they were sized according to the size they would be if they were a Vidicon tube. The imperial fractions represent the diameter of the Vidicon tube. Although it has no direct relationship on the size of the imaging sensor; it is always roughly two thirds [dpreview, Accessed 2006]. Figure 3.2 shows the difference in size of the CCD imaging sensor in comparison to its corresponding Vidicon tube size. Table 3.1 represents the dimensions of several common CCD formats.

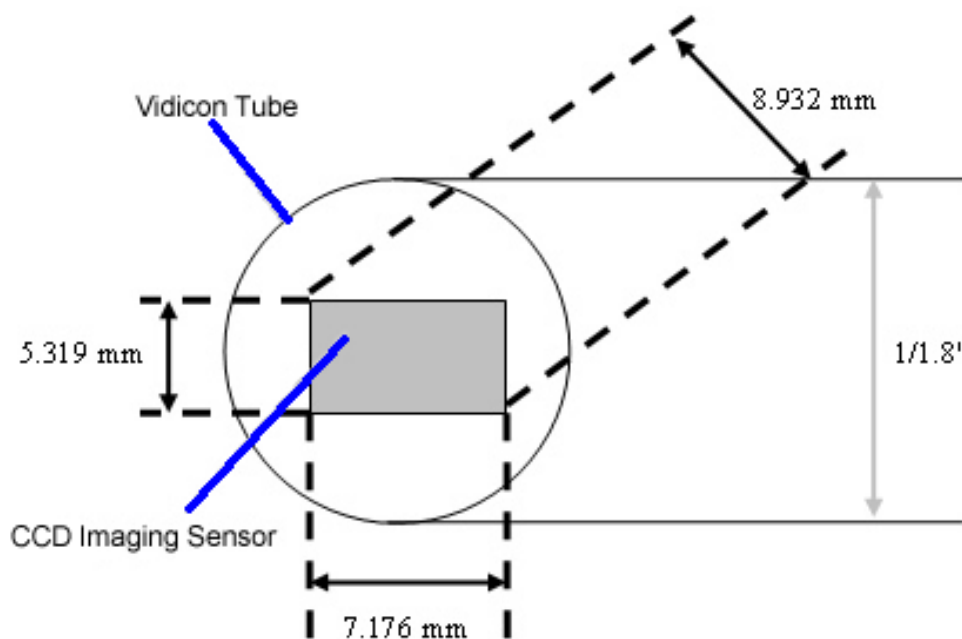

**Figure 3.2** – An example of the CCD Format compared to its Equivalent Vidicon Tube.

Format	Sensor Size (mm)		
	Width	Height	Diagonal
1/6"	2.15	1.61	2.7
1/4"	3.2	2.4	4
1/3.6"	4	3	5
1/3"	4.8	3.6	6
1/2"	6.4	4.8	8
1/1.8"	7.176	5.319	8.932
2/3"	8.8	6.6	11

**Table 3.1** – Dimensions of Several CCD Formats.

### 3.3.2 Film Versus Digital Photography

The ever expanding field of technology has not only brought about an increase in the quality of digital photography but an enhanced sense of familiarity. Both conventional film photography and digital photography share many similarities, yet display a range of attribute belonging only to a specific medium. The advantages and disadvantages of these characteristic will demonstrate the strengths and weaknesses of digital photography.

In the past, the quality of images captured using conventional film photography surpasses those obtained with a digital camera; achieving higher resolution and greater dynamic range. This allowed for superior capture of both shadow and highlight details over its digital counterpart. Redsicker says “With each passing day, the quality of the two mediums becomes harder to differentiate” [Redsicker, 2001]. This is certainly true with the expanding technology as digital cameras have become so advanced that the balance of quality has been shifted in its favour. This is evident in the Spheron digital camera with a dynamic range of up to 26 aperture stops and the Hasselblad H2D digital camera with a 39 mega pixels capability. Conventional film cameras are generally less expensive than high resolution digital camera costing in the region of \$32,000 for the Hasselblad H2D digital camera.

Perhaps one of the greatest qualities of digital photography is their ability to provide an instant evaluation of the captured image through a liquid crystal display (LCD) screen, available on most digital cameras. The advantages of a preview ensure that a superior

quality image has been captured with the correct exposure and lighting as well as all relevant parts of the scene. Inadequate images can be determined quickly and taken again. Images can be transferred directly to a computer for more detailed viewing or printed for a hard copy. This eliminates the need for a chemical photo lab; required by conventional film photography and therefore there no negatives that can be lost or damaged during processing [Advanced Imaging and Analysis, 1998]. This can also improve health and safety and provide a low cost and time saving solution in capturing images.

The absent of image degradation is limited to digital information. In digital photography, a copy of an image results in a precise duplication; with no loss in image quality between generations. This is one of the great benefits of digital technology [House of Lords, 1998]. Contrastingly conventional film photography is analogue in nature and therefore a copy of an image provides an inferior copy and further copy of a copy produces further degradation in quality.

Controversy surrounds digital photography in regards to the ease in which digital images can be manipulated and enhanced. There exists a wide variety of commercially available graphic software that gives users the ability to alter images with little difficulty. Shared by many is the misconception that conventional film photography cannot be altered which further strengthens the belief that digital images are inferior to their conventional counterparts [Advanced Imaging and Analysis. 1999]. Distinguishing between enhancement and manipulation is an important step in tackling these concerns and the use of standard operating procedures (SOP) will help in ensuring admissibility.

### **3.4 Virtual Environments**

Traditional means of crime scene documentation are effective, yet they are slow and cumbersome. While a photograph captures a scene from a single viewpoint, a VE offers the advantage of multiple viewpoints from the same location. VE; a type of VR is an “interactive real time environment that is simulated by a computer and responds to user input and action” [Schofield, 2002]. A key component in most VR systems is the

ability to perform a walkthrough of a VE from different viewing positions and orientations. It engages the user with interactivity, imparting an experience of actual present. The use of VR has mainly been associated with training applications; i.e. flight simulations used to train pilots. With the rapid development in computer technology, applications of VR are becoming more common place in many areas including law enforcement. The computer game industry has driven this technology forward and brought its potential to a wider audience.

This thesis explores the application and benefits of VR technology in the documentation of crime scenes. In the past, the difficulties associated with the construction of a VE were immense; requiring expertise in computer graphics. However, with growth in computer software, it has become a simpler task.

### **3.4.1 Various Approach of Virtual Environments**

There are two types of VEs: graphics based virtual reality (GBVR) and image based virtual reality (IBVR). These vary significantly in terms of the appearance, interactivity and user freedom. Advantages and disadvantages associated with each of these methods will be discussed in this section.

GBVR is the traditional means of generating a VE. This is a geometry based approach and essentially is a collection of 3D geometrical entities. Using CAD software, physical measurements and blueprints, accurate constructions of VE can be achieved. An example of CAD constructed VE is shown in Figure 3.3.



**Figure 3.3** – 3D CAD Model [Gibson, 2000].

One of the fundamental weaknesses of GBVR is the lack of realism that is exhibited. Studies have been carried out in an attempt to enhance the VE by application of texture maps and other techniques onto the surface of 3D models [Kang, 1999]. This provides an enhanced sense of immersion that the user experiences. GBVR allows the user the freedom to explore the VE from any angle or position within the scene. This flexibility of movement within the scene is an important and beneficial aspect of GBVR that is not shared by IBVR.

There are a number of problems associated with the GBVR approach. The first problem is the cost of construction. Since the process of building a 3D CAD model is both labour intensive and requires much expertise, only the simplest or most high profile of cases can warrant its use. The rendering performance of GBVR is dependent on the complexity of the constructed scene. Therefore, in order to achieve a real time performance, GBVR scenes require high quality graphics accelerators to render the scene adequately. Although the cost of graphics accelerators have decrease over the years and become standard equipment in most personal computers, Chen says “real time rendering problem still remains since there is really no upper bound on rendering quality or scene complexity” [Chen, 1995]. This is one of the fundamental disadvantages of GBVR. The complexity of a scene is directly related to the number of objects that the creator decides to construct.

The application of GBVR in a forensic setting has been more widespread than IBVR. Studies have been in progress which attempt in tackling some of the problems of GBVR that have been discussed and also its application within the forensic field. One such study is the Reconstruction of Virtual Environments with Accurate Lighting (REVEAL) project; carried out by the University of Manchester and in collaboration with the Greater Manchester police force. The focus of the REVEAL project is the investigation of a semi-automatic techniques that aid in the extraction of geometric and illumination information from photographs in the construction of a VE [Gibson, 2000]. The result of the study was applied to scene of crime reconstruction and provided value data for further studies.

Due to the problems encountered with GBVR, there has been the emergence of a competing means of creating VE known as IBVR. This alternative technique possesses some of the benefits of a 3D model at a fraction of the cost. The image based approach constructs a VE by utilising a series of photographs at a number of viewpoints to generate a panorama for each viewpoint. Through the advances in panoramic hardware and software, simulation of photo-realistic VE is made possible.

IBVR is a combination of CG and digital images that allows navigation through a scene and delivers a high quality photorealistic VR experience, opposed to the use of polygons employed with GBVR. Where real time rendering of GBVR is affected by the complexity of the scene, IBVR has no such restriction [Li, Accessed 2006]. Due to the fixed dimension of each panoramic image, the number of pixels to be processed is also limited [Chiang, 1997]. This feature allows a smooth navigation even in arbitrarily complex and detailed scenes [Cuntz, 2002]. IBVR demands less computing power and allows playback at interactive speed without the need for hardware acceleration; though it places high demands on the system memory.

Construction of a VE using the image based approach is restricted to a 2D representation and users cannot freely explore or interact with objects in 3D world space [Chiang, 1997]. Interaction of IBVR systems is limited to the viewpoints from which the images were captured. Table 3.2 shows the comparison between the two classes of VE techniques. This thesis will focus upon the use of IBVR as the principle method of constructing a VE. The following subsections will expand on the techniques of IBVR and its various subtypes.

<b>Graphic Based Virtual Reality (GBVR)</b>	<b>Image Based Virtual Reality (IBVR)</b>
Explicit use of 3D models	Directly uses collection of images
Uses conventional rendering pipeline	Based on interpolation or pixel reprojection
Speed dependent on scene complexity	Speed independent of scene complexity
Relies on hardware accelerator for speed	Relies on processor speed
Requires sophisticated software for realism	Realism dependent on input images

**Table 3.2** – Comparison of the Two Classes of VE Techniques [Kang, 1999].

### 3.4.2 Panorama

An interactive panorama is an IBVR; an unusually wide image of a scene. Through the use of an environment map, a panoramic image becomes an immersive experience. An environment map is a projection of a panorama onto a simple shape [Chen, 1995]. The perspective of a panoramic image is changed by software in order to present a realistic display of the panorama on a computer screen. The absence of such projection results in a distorted appearance. An interactive panorama creates the feeling of actually being present at the scene itself and offers in some cases a full 360° by 180° view. The actual horizontal and vertical range is determined by the environment map utilized [Apple Computer, 2005] along with the hardware and techniques used to capture the images. Currently there are three different types of environmental maps: cylindrical, spherical and cubic [Jacobs, 2004].

#### 3.4.2.1 Cylindrical

A cylindrical panorama is the most common type of environmental maps. It is achieved by projection onto the inside of a cylinder giving the feeling of standing inside a can. A cylindrical projection is shown in Figure 3.4. This allows panning left and right by correction of distortion horizontally to give a picture that looks more normal. Cylindrical panoramas are limited by their vertical field of view (VFOV) and therefore do not possess the ability to pan directly up and down. Correction is not applied vertically and panoramas achieved through wide angle lenses will appear distorted [Panoguide, Accessed 2006].

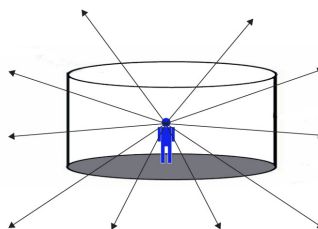

**Figure 3.4** – Cylindrical Projections.

#### 3.4.2.2 Spherical

Spherical panoramas are achieved through the projection onto the inside of a sphere giving the feeling of standing inside a bubble as illustrated in Figure 3.5. The horizontal capability of a spherical panorama allows the viewer to pan 360°. Spherical panoramas offer greater flexibility than the simpler cylindrical panorama in terms of the vertical

pivoting range. As discussed, cylindrical panoramas are limited by their ability to pan directly up and down whereas a spherical panorama places no limitation on the vertical angle.



**Figure 3.5** – Spherical Projections.

#### 3.4.2.3 Cubic

As with a spherical panorama, cubic panoramas possess the same ability in terms of panning  $360^\circ$  horizontally as well as  $180^\circ$  vertically. The main difference lies in the projection of the panorama onto the inside of a cube rather than a sphere as illustrated in Figure 3.6. Six quadratic pictures are required for this format. The underlying panoramic image used in the projection of a cubic and spherical panoramic are virtually identical and difficult to distinguish between the two.

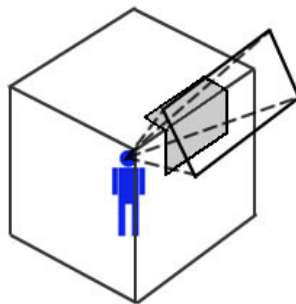

**Figure 3.6** – Cubic Projections.

Cubic and spherical panorama both correct distortion horizontally and vertically to provide a seamless image. However, compared to cylindrical panoramas, cubic and spherical panorama produces a larger resultant file and place a greater burden on the computer's central processing unit (CPU) resulting in a slightly slower loading times and panning motion [Panoguide, Accessed 2006].



### 3.4.3 Hardware

The increase interest in panoramic images by professionals and the public have driven the technology forward and there now exists a wide range of commercial hardware and software techniques available for generating a panorama. Although the resultant panorama are visually similar, the techniques differ in terms of the quality of the captured images, the cost of equipment, the degree of vertical pivotal range and the required image stitching process. These techniques are discussed further.

#### 3.4.3.1 Standard Cameras (Single-Row)

Perhaps one of the most common techniques used to capture the images required for the creation of a panorama is the utilisation of standard off-the-shelf cameras. This generally does not require expensive equipment and therefore provides a low cost solution to generating a panorama; bringing the technology not only to professionals but to the general public.

The technique of single-row capture as illustrated in Figure 3.7 involves capturing a series of overlapping images which will later be stitched together into a single, seamless image. The camera; mounted on a tripod is rotated around the nodal point of the lens while the individual images are captured [See Appendix A]. The camera is usually mounted sideways to obtain the maximum vertical field of view [Chen, 1995].

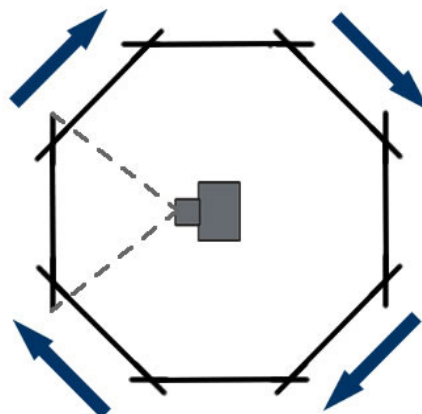

**Figure 3.7** – Standard Camera (Single-Row) Technique.

The degree of rotation of each image required to achieve the desired percentage overlap is dependent on the field of view (FOV) of the respective lens. A recommended overlap of at least 30% and no more than 50% is usually cited [Anderson, Accessed 2006]. With such overlap, it provides sufficient common points for greater accuracy in the subsequent stitching process. A large percentage overlap has the affect of increase quality of the panorama and a more subtle transition between each image. Consequently it requires the capture of a greater number of images, which not only requires more time for the capture and stitching process, but also places a greater burden on the system memory during playback. Particular disadvantage of this technique is its vulnerability to movements of objects within the scene from one image to the next, resulting in blurring at the corresponding joining location of the panorama.

Alternatively, with the addition of an 8mm fisheye lens attachment, the FOV of the lens exceeds 180° allowing a complete panoramic capture with just two images. The process involves capturing the first image and then rotating the camera 180° for capture of the second image. This produces two hemispheric images which through the application of software to correct the distortion can then be stitched together to produce a spherical panorama with a 360° by 180° FOV. The resultant panorama is lower in resolution than the traditional technique due to the small number of images, although the time involved in capturing the images are relatively short. In addition, the problem with movement of object within the scene is moderately low due to the large FOV associated with fisheye lenses.

One company that has provided this fisheye lens solution is Interactive Picture Corporation (IPIX). Due to IPIX's patent claim on the intellectual property, the routines for capturing and stitching images taken with a fisheye lens are protected by the patent and a fixed fee must be paid for every panorama published [Obeysekare, 2000].

As an alternative to the IPIX fisheye lens technique, a parabolic mirror; positioned horizontally can be used. Shooting the images of the parabolic mirror, you are essentially capturing images similar to those of the fisheye lens. Since no fisheye lens is used, there is no infringement of the IPIX patents [Panoguide, Accessed 2006].

### 3.4.3.2 Multi-row

The vertical pivotal range using the standard camera single-row technique is limited by the VFOV of the lens. However, using a multiple-row technique, the vertical pivoting range can essentially be increased.

The process is initially identical to the single-row technique by capturing a series of individual images horizontally. In order to extend the VFOV, additional images are captured for each rows of the scene by pitching the camera up and down as illustrated in Figure 3.8. By capturing an image straight up and down provides a completion to a 360° by 180° panorama and ensures the panorama blends well with the images in the topmost and bottom row [Stitcher, 2003]. The high number of images captured ultimately results in a higher resolution panorama; however this increases the capture time, memory requirement and the time needed for stitching.

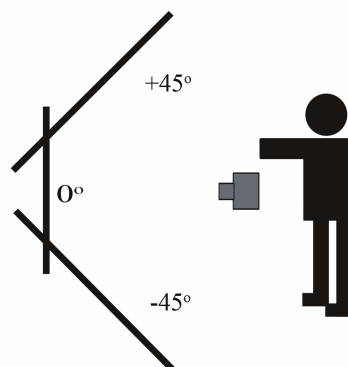

**Figure 3.8** – Multi-row Technique.

A panoramic tripod head is recommended for both single-row and multi-row shots. The purpose of this equipment is to exactly align the rotation of the camera around the camera's nodal point. Failure to achieve this aligned rotation result in parallax of the images and ultimately failure of the images to stitch [See Appendix A for information on the nodal point and the affect of parallax]. There are a few companies such as Kaiden that specialise in providing panoramic tripod heads for the sole purpose of capturing the images for a panorama [Kaidan, Accessed 2006]. The majority of these involve a manual approach, where the tripod head is rotated by hand. Due to the specialised nature of the equipment, they tend to be costly.

Automated tripod heads are rare and have a price tag that is out of reach of the common user. The 'FOX' system produced by Instro is shown in Figure 3.9. Although not specifically designed for panoramic images, it has a remote controlled pan and tilt head that provides a means of positioning a variety of optical systems when used with a tripod [Instro, Accessed 2006].



**Figure 3.9** – FOX System [Instro, Accessed 2006].

The 'PixOrb' produced by Peace River Studios is a system designed specifically for panoramic photography. This is shown in Figure 3.10. It comprises of a motorised head which has two axis of rotation for capturing spherical and cylindrical panoramas. The system is battery operated enabling portability and is programmable for any number and size of pan and tilts increments [Peace River Studio, Accessed 2006].



**Figure 3.10** – PixOrb Panoramic System [Peace River Studio, Accessed 2006].

### **3.4.3.3 Video cameras**

The use of video cameras in place of digital cameras is possible but not without its drawbacks. The problem lies with the resolution in today's commercially available video cameras. Currently, the Digital Video (DV) format offers a resolution of 720 × 480 pixel. Even with the emerging high definition camcorder offering a resolution of 1440 × 1080 pixels, it does not come close to digital cameras in terms of the resolutions of the images.

Studies exploring the use of video cameras in constructing panoramic images of real world scenes have been carried out including attempts to automate the process. Chen and his team were able to construct panoramas by panning a video camera in a scene and through software, automatically select the essential frames and stitch them together to produce the resultant panorama [Chen, 1998]. However, the problems with resolution still holds true and therefore video cameras is not a viable option in scenes where high quality images are required.

### **3.4.3.4 Panoramic Cameras**

Panoramic cameras are designed solely for the purpose of capturing a panorama. Therefore there are no unnecessary functions of the camera and setup is kept simple. The use of panoramic cameras has the advantages of enabling the acquisition of panoramic images and the creation of panorama easier [Huang, 1997]. An example of a panoramic camera system is the Spheron camera shown in Figure 3.11 which is produced by a German based company [Spheron VR, Accessed 2006]. This particular camera has the ability to capture a scene with a contrast range of up to 26 aperture stops [Jacob, 2004] allowing dark or bright areas within the scene to be seen clearly.

The system possesses a motor that rotates the camera around its vertical axis while the CCD sensor samples the scene, strip by vertical strip. The images are sent direct to the computer via Universal Serial Bus (USB) and are displayed in real time. This camera has the capability of capturing a 360° by 180° panoramic image without the need to stitch multiple images. However, the substantial cost associated with the equipment puts this out of reach of most users.



**Figure 3.11** – Spheron Camera [Spheron VR, Accessed 2006].

### 3.4.3.5 One Shot Solutions

One shot solutions employ the use of curved mirror that allow the capture of the scene in one image eliminating the need to stitch any images. Creation of panorama using stitching techniques is prone to movement of objects within the scene. With the use of one shot solution, this problem is essentially eliminated. However, these techniques have a limited VFOV and therefore are restricted to cylindrical panoramas. Since only one image is captured, low resolution panoramas are associated with this technique which is governed by the maximum resolution of the camera chip. The use of one shot solution is relatively expensive compared with other techniques and the fragile nature of the lens has contributed to its low spread use.

Such devices like the Portal S1 system by BeHere Co and the Cyclovision Parashot shown in Figure 3.12 uses a mirror device that attaches to the camera using a standards lens mount.



**Figure 3.12** – Portal S1 and Cyclovision Parashot One Shot Solutions [Obeysekare, 2000].

The lens provides a horizontal field of view (HFOV) of 360° and VFOV of 100° and 105° respectively. Using software provided by the vendor, the donut shaped image generated from the lens can be unwrapped to a seamless panorama [Obeysekare, 2000].

#### **3.4.4 Stitching Software**

Following the capture process, application of stitching software stitches the individual images together to produce a seamless panorama. Although the software itself is not a component of the thesis, its application is nevertheless an important step in creating the resultant panorama from the images acquired through the proposed imaging system.

There is a vast number of commercially available panoramic stitching software. Although the capabilities and ease of use of each software may vary somewhat, they essentially perform the same basic task. However, a few of the software are more developed and possess additional features that aim to enhance the overall panorama experience. In order to determine the most suitable stitching software to employ in the thesis, careful consideration must be given to the needs of the images and the type of output panorama and whether the software can fulfil these requirements. The software must have the ability to:

- Output QuickTime Virtual Reality (QTVR) format.
- Create Single-Row panorama.
- Create Multi-row panorama.
- Create Cylindrical panorama.
- Create Spherical or Cubic panorama.
- Create Hotspots on the resultant panorama.
- Support a wide range of cameras.
- Support wide range of image formats.
- Support high resolution input images.

Following a series of trials with a variety of stitching software, it was concluded that Realviz Stitcher provided ease of use and offered the required features that was sought

after [Stitcher, 2003]. Subsequent panoramas created within the thesis will thus employ the use of Realviz Stitcher.

### 3.4.5 Displaying of the Panorama

There are a number of commercially available software's on the market known as 'viewers' with the sole purpose of displaying the stitched panoramas. This provides the interface through which the user gains an immersive and interactive experience. Viewed by itself, the panoramic image appears distorted, but through the viewer software, the distortion is automatically corrected at runtime [Apple Computer, 2005].

A pioneer of the IBVR approach in a commercial setting is Apple's QTVR player. Other platforms that have emerged as a competing alternative to QTVR have included PTVviewer and Java-based players. These differ in terms of their quality and performance [IQTVRA, Accessed 2006]. In order to be able to open the various viewer formats, their corresponding plug-in must be installed. QTVR is the leading panoramic platform and offers superior quality and excellent performance [IQTVRA, Accessed 2006]. For these reasons, the thesis aims to utilise the QTVR platform for displaying panoramas.

Built on top of Apple Computer's QuickTime (QT) digital multimedia framework, QTVR extends its interactive capabilities by creating an immersive user experience that simulates 3D scenes and objects [Apple Computer, 2005]. QTVR is a cross platform player that runs on both Macintosh and Windows. The capabilities of QT have been extended through the addition of new types of tracks that have been added to the existing architecture. Figure 3.13 illustrates the structure of the tracks present in a QTVR panoramic movie.



**Figure 3.13** – QTVR Structure.



The QTVR user interface controller allows users to navigate and explore the panorama. This component is stored in the QTVR extension and is loaded automatically whenever an application with QTVR movie requires it. Figure 3.14 shows an example of the user's interface which controls the panning motion of the panorama.

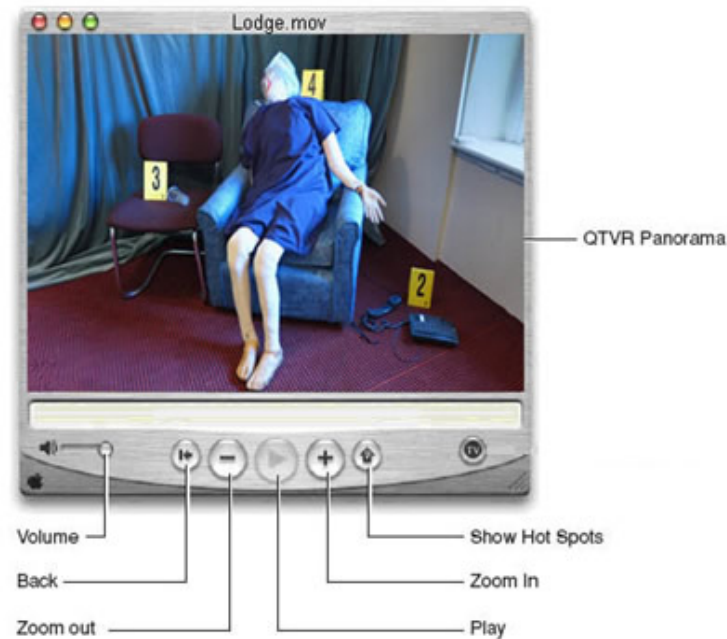

**Figure 3.14** – QTVR User Interface.

The QTVR user controller provides an easy to use interface to explore a QTVR scene. These are:

- **A Back Button** – Allows the user to return to the previous node. This button is enabled only for multimode movies.
- **A Zoom-Out Button** – Allows the user to zoom out causing the field of view of the displayed node to increase. This gives the illusion that the panorama is moving away from the viewer.
- **A Zoom-In Button** – In contrast to the zoom out button, the user can zoom in. This causes the field of view of the displayed node to decrease with the panorama appearing to move toward the viewer.
- **A Hot Spot Display Button** – Pressing the hot spot display button highlights the visible hot spots.

### **3.4.6 Virtual Tour**

A panorama consists of a view from a single position (or viewpoint) which is defined as a node. A virtual tour contains a single scene which is a collection of one or more nodes. When a virtual scene contains more than one node, the illusion of movement through the scene can be created by jumping from one node to another. In order to preserve continuity of motion, the view direction needs to be maintained when jumping to an adjacent location [Apple Computer, 2005]. A distance of about two metres between the grid points gives a very good spatial impression [Cuntz, 2002].

A multiple node virtual tour allows movement from one node to another through a link between the source and destination nodes. The link defined as a 'hot spot' is graphically represented on the source node. When clicked, the action is performed and moves the user from one node in a scene to another node. However other types of hot spot are available which perform another action and expands the capabilities of a virtual scene.

Hot spots are areas in a panorama or object movie that link to a node, file or URL. Each hot spot contains all information about the destination action, and the corresponding region on the panoramic image [Chiang, 1997]. This feature enables other material such as maps, still photographs, video footage, fingerprints, tyre prints to be incorporated into the virtual scene. For example, the location where the prints were found can be easily related to the scene and displayed by activation of the hot spots. Hot Spots in QTVR movies extend the interaction between the viewer and the QTVR scene, helping to make this virtual experience more real. "Going beyond the basic dragging up or down, left or right while standing here, hot spots are the magic portals that link you from this movie here to another movie there" [Kitchens, 1998].

### **3.4.7 Current Areas of Use**

Originally used in areas that were deemed too hazardous for humans, such as oil rigs, panoramic technology has generated a great deal of interest within many different industries. Its application strives to increase productivity and provide an extra level of interactivity for consumers.

Some of the industries at the forefront in the application of panoramic technology have been real estate, travel agents and museums [Kitchens, 1998]. The technology gives potential consumers the ability to visit remote locations over the web and experience what the location has to offer beforehand. Education can also benefit from such technology by allowing students to visit an important location relevant to their lesson. Teachers report that students become more interested in academic content after a real or virtual field trip that brings the subject matter to life and gives them a lifelike experience [Benton, 2002].

The benefits of panorama are not limited to the commercial market. In conjunction with the sheriff's Safe Schools Unit and local school districts, panoramas are being used to build virtual school campuses that public safety planners can use for emergency and disaster planning [Panoscan, Accessed 2006]. In addition, panoramas have emerged in computer games such as 'Crime Scene Investigator', where it involves navigation through VEs and solving puzzle [UBISoft, Accessed 2006]. The application of panoramic technology within the area of law enforcement is relatively novel in comparison to the other industries but commercial products are now emerging that aim to fill this niche. These will be discussed further in section (3.9).

### **3.5 Visual Aids**

The use of the expert witness has become prevalent over the years; from high profile cases such as murders to medical malpractices. The ability to portray evidence in a logical manner remains a difficult task and all too often a jury must form a mental image of the crime scene through photographs, drawings and verbal testimony [McCracken, 1999]. While these remain the standard, they pose numerous questions to the effectiveness in communicating to the jury. Evidence is meaningless if it cannot be conveyed effectively. Lederer says "Communication is at the heart of litigation; everything else is secondary" [Lederer, 1994b].

Krieger notes "the value of demonstrative evidence to help jurors understand complex issues has long been recognized by experienced trial lawyers [Krieger, 1992]. Studies have shown that jurors are often left confused, bored and even frustrated when

confronted with technical issues or complex facts. It is reported that the “sheer volume of information overwhelms the jury” resulting in difficulty when trying to recall important facts [Krieger, 1992]. Further emphasizing the importance of visual aid in communicating complex evidence, Krieger notes that “the ‘Weiss-McGrath Report’ found a 100 percent increase in juror retention of visual over oral presentations and a 650 percent increase in juror retention of combined visual and oral presentations over oral presentations alone” [Krieger, 1992].

### **3.5.1 Types of Visual Aids**

Development of digital technology has provided more advanced visual presentations tools to the expert. However, the use of traditional techniques should not be overlooked, as often is said, “Simpler is better”.

Scale models are an effective tool to aid jury comprehension of a crime scene. Through numerous measurements, they can accurately depict correct spatial distance and relationship of evidence including the surrounding objects. Proper placement of light switches, outlets, furniture assist in the overall accuracy of the scene so there is no doubt; when photographs are compared as to what the model is showing [McCracken, 1999]. Despite the advantages of using scale models, construction is a very time consuming and tedious task and care must be taken to prevent damage to the finished presentation.

The use of visual aid has been limited to techniques such as hand-drawn diagrams, charts and photographs; although very effective, they are limited by their flexibility. In recent years, advances in computer hardware and software have brought the reality of CG displays to the courtroom and within the litigation budget of all but the smallest cases [Krieger, 1992]. The use of CG displays and digital images in the courtroom will be discussed in the next section since the IBVR technique is a combination of both.

### **3.5.2 Computer Generated Displays and the Courtroom**

The use of CG displays in modern society forms an extensive and integral component in everyday presentation from news media and entertainment to sales. This trend has

transferred over to the law enforcement community showing real progress and gradual recognition within the field.

As a tool, computer graphics in the courtroom is an excellent means to convey complex information in an accessible and easily understood, visual manner [Schofield, 2000]. As Muir expresses about CG displays “they offer a bridge for the technical community to communicate complex issues to a lay audience” [O’Flaherty, 1996].

Beneficial use of CG display in the courtroom does not stop at just a way of presenting pleasant pictures to the jury; it can often communicate at more than one level with the jury from the initial presentation and beyond. There are three main benefits associated with its use in the courtroom [O’Flaherty, 1996]. Foremost is the ability of CG display to provide an effective means of conveying evidence to aid jury and judge understanding. Presenting complex information in such a manner allows for quick and easy comprehension of the evidence, thus saving time and money. The second benefits of CG involve the archiving of evidence; allowing all case related information to be stored on a single DVD. This allows quick accessibility, eliminating the need for numerous boxes of paper. The third benefit associated with CG display is the persuasive nature of such technology which will be discussed further in subsection (3.5.2.3).

The US courts are at the forefront in the use of CG evidence. There have been a vast number of cases involving the use of CG in the courtroom which has demonstrated the overwhelming advantage of this technology [Schofield, 2000]. In contrast, the emergence of CG evidence in UK courts is relatively new. Widespread application of CG display technology in most other industries along with the identification of the potentially important role of IT in future justice system have been noted in the Woolf report “Access to Justice” [Narayana, 2001]. Within the England and Wales legal system, the Woolf Report documents an increase in use and promotion of IT. A study by the American Bar Association in 1992 reported that in the US, “13 percent of medium-sized law firms have used computer animation in cases, and that 45 percent of them planned to use it in the future” [Krieger, 1992]. This figure will undoubtedly be

far greater in today's US court. This helps demonstrate that the US has recognised the potential of CG evidence in the courtroom far earlier than the UK and as such are pioneers in this field. Reference to relevant case law from the US can aid the development of CG evidence in the UK's courtroom by providing essential information regarding admissibility requirements and potential opposition. This thesis will explore the use of CG evidence in both the US and UK courtrooms and some of the problems faced.

### **3.5.2.1 USA**

The majority of CG evidence in the US has been limited to civil cases such as personal injury, product liability and patent infringement [Noond, 2002]. On August 2<sup>nd</sup>, 1985, legal history was made with the first major use of CG evidence in court. All one hundred and twenty eight passengers, eight crew members, and one person on the ground died as a result of Delta flight 191 crashing on landing during violent winds [Selbak, 1994]. A fourteen month legal battle followed between Delta airline and the US government, over who would pay the \$150 million to \$200 million worth of claims for wrongful death and loss of aircraft. Delta airlines sought to place blame for the crash on air traffic controllers [Krieger, 1992]. The US government introduced to the jury a CG presentation as a means of explaining the details of each item of evidence and key findings. Subsequently, the US government prevailed in the case. The case marked a pivotal point for the use of CG evidence and it encouraged wider acceptance of the technology by other judges and courts [Selbak, 1994].

Another successful use of CG evidence involved the highly publicised 'Snoop Doggy Dogg' trial where gangster rapper Calvin Broadus (aka 'Snoop Doggy Dogg') and his former bodyguard, McKinley Lee were acquitted of killing a former rival gang member, Philip Woldemariam. Prosecutors claimed that McKinley, who was seated in the passenger's seat of Broadus's jeep, signalled for Woldemariam to approach and then reached for his gun and shot him in the back twice as he attempted to escape [D'Angelo, 1998]. However, the defence disputed that the shooting was an act of self-defence and that Woldemariam had pulled a handgun and shot at the vehicle.

The jury was left with deciding between two accounts of what may have transpired. With considerable amount of funds at their disposal, the defence utilised sophisticated CG illustrations in support of its self-defence theory. Complex evidence, which normally would require numerous expert witnesses and hours of testimony, was easily presented to the jury in the form of a brief 3D computer animated video [D'Angelo, 1998]. Consistent with the defence's self-defence theory, the CG display was able to show the trajectories of the two bullets including their corresponding entry and exit point. Through slow motion images, the display conveyed that the force and angle of the first shot on the victim's body rotated him slightly, causing the second shot to enter his back. The jury acquitted the defendant on the charges of 1<sup>st</sup> and 2<sup>nd</sup> degree murder [Girvan, 2001b].

The first USA case to allow VR evidence was *Stephenson v Honda Motors Ltd.*, 1992 Case No. 81067 in which the evidence concerned riding a motorbike across difficult terrain. The evidence was allowed because it was argued that while 2D photographs and videos would certainly help the jury to understand the terrain, a 3D view would be more realistic. The court allowed the evidence, agreeing that this view was more informative, relevant, and probative [Girvan, 2001b].

### **3.5.2.2 UK**

The use of computer technology has already been well-established in the US; yet it remains in its infancy within the UK. Explanation for this slow development has been quoted which includes "lack of skills, distrust about the use of computers and deficient technology in courtroom to deal with such technology" [Lederer, 1994b]. There has however, been an increasing use of this technology in recent times and a few pivotal cases which are changing the ways in which we view this technology within the UK.

In September 1994, the Oxford Crown Court was host to the first instance of CG displays within the UK involving the case of *R v Wharton*. Prosecuted by the Serious Fraud Office, the defendant was convicted of fraudulent trading. During the course of the hearing, over a hundred CG displays were shown to illustrate some transaction sequence [Horten, 1994].

The case of *R v Ore* in November 1998 at Birmingham Crown Court saw the early use of CG display in front of a jury [Girvan, 2001]. In this case the defendant was charged with causing death by dangerous driving. Called by the prosecution, police constable (PC) Mike Doyle of the West Midlands Police Crash Investigation and Training Unit was requested to give evidence. As a part of his evidence he produced and displayed by means of a video, a 15 second computer simulation that he had created using Autodesk's 3D Studio software. Based upon information and figures obtained at the crash site, the reconstruction showed the sequence of events that transpired between the defendant and victim's vehicles; noting the position of the vehicles prior to, during and following collision. Despite the use of such technology, the defendant was acquitted of the offence [Girvan, 2001]. Since then a number of CG displays have been admitted to UK courtrooms [Schofield, 2002].

The 1999 West Midlands Walsall Coroner's inquest saw the use of CG evidence to help establish the events that led up to the death of two motorcyclists. Visualisation of how the deaths occurred was made possible by showing how they collided with a vehicle that pulled out across their path at a junction. The interactive nature of the presentation allowed for key moments to be stopped in court and discussed before processing [Noond, 2002].

One of the most extensive uses of digital technology in the UK courts' was presented for the August 2002 Soham murders. This highly publicised trial of Ian Huntley in the murders of Holly Wells and Jessica Chapman involved the presentation of complex forensic evidence. Utilising the full resources of the imaging unit of West Yorkshire Police, a unique digital video disc (DVD) presentation was put together for trial encompassing all relevant case material; everything from the images and video interviews to a simple witness statement. This is thought to be the first for a UK court case [Gower, 2004]. The presentation package included a series of 3D reconstructions, showing the Soham village, the last known route the girls had taken and exactly how Ian Huntley might have tried to conceal the girls' partially burned clothes in the bin at the school [Morris, 2003]. Use of complete set of 360 degree panoramas provided the



jury with views of all the major scenes in the investigation [Gower, 2004]. Subsequently, Ian Huntley was found guilty on both counts of murder.

This type of presentation was praised by numerous individuals including Sir Ronnie Flanagan; Chief Constable of both the Police Service of Northern Ireland and Royal Ulster Constabulary and Ken Macdonald QC; Director of public prosecution. Sir Ronnie said “using the technology represented a very significant saving of time and enabled everyone in the court fully to appreciate all aspects of the prosecution’s case” [Gower, 2004]. Mr Peter Burton, manager of the imaging unit said “the alternative to using a single DVD like in the Soham case would have been a trial with a slow trickle of paperwork smothering the courtroom” [Gower, 2004].

### **3.5.2.3 Persuasive Impact of Computer Images**

Computer displays as an instrument of persuasion should not be underestimated. The inherent dangers associated with the use of computer images are the impact that they can have on the jury. Jury’s often takes the view that computers are superior and never lie. The impact that CG displays impart on the viewer gives rise to a significant potential for misuse and prejudice.

The credibility that jurors place on computers is founded from Television shows such as Crime Scene Investigator (CSI) which Michael Gorn, a forensic scientist says “has given people unrealistic expectation of what can be performed and the time frame in which this can be achieved” [Hempel, 2003]. Calling this the “CSI effect”, the increasing role of computer animations in these types of Television shows create an almost “built-in credibility” in the minds of jurors who view it at trial [D’Angelo, 1998]. In the Supreme Court of New York in the case of McHugh, it was found that computers were merely “a mechanical tool receiving information and acting on instructions at lightning speed in the presentation of factual evidence”. This statement is a misconception and gives rise to believe that all computer animations are true factual statements. It encourages juror to surrender their role in factual determinations and allow the computer to resolve the factual disputes in the case; essentially placing CG evidence as the absolute conclusion [Selbak, 1994].

This biased nature of CG evidence is evident more so in cases where only one of the legal parties uses the technology, because it means that one side of the case can be very persuasive. Out of 858 cases in the US where one party used animations, all but 15 settled out of court. Of the 15 that went to court the side using the animation always won [O'Flaherty, 1996]. Reasons cited for the lack of use is down to cost. While the cost associated with creation of CG displays has become more affordable in recent years, it still remains relatively expensive and therefore out of reach of most but the wealthier parties.

This bias towards the parties that use CG evidence has led at least one court to preclude its use. In the case of *Racz V R.T.Merryman Trucking, Inc*, the defendant's CG recreation of the accident was precluded from the trials on the grounds that unfair prejudice to the plaintiff. The court recited the old adage, "seeing is believing," articulating that the jury might give undue weight to a computer recreation and may lead them to accept the data and expert opinion as the definitive conclusion [Selbak, 1994].

With the exposure of CG displays on television and in the movies, jurors have become accustomed to receiving information through this medium. Not only is this form of presenting information a more stimulating method, its psychological impact on juries extend far beyond that which can be achieved purely by verbal presentations. Studies have shown that information retention is affected by the medium through which the information is relayed. It was found that sixty-five percent of jurors that received information through a combination of oral and visual evidence could recall the evidence presented three days later. Where only oral evidence was presented, only 10 percent of this was retained by the jurors [Selbak, 1994]. In another series of studies, the Crash Investigation and Training Unit (CITU) in the UK presented three separate groups with a series of accident information. The first group received the information in the form of a textual description; a second group was shown images and the third group a combination of both text and images. The group that performed the worst with the most errors was group one, which received only descriptive information, whereas the group that was shown both text and images performed the best (Doyle, 1999) [Schofield, 2000]. Berkoff says "it is clear that visual presentation is more effective than verbal

communication, and that verbal communication is most effective when coupled with a visual presentation” [O’Flaherty, 1996]. Essentially humans have a pictorial memory which far surpasses our verbal memory. Although, the studies have shown that the most important method of communicating technical information is through visualisation, there are many questions which remain unanswered concerning the impact of such visualisation on the jury.

The emotive nature of some cases can introduce bias into the court especially when the crimes have involved considerable violence. Therefore, in order to remove this bias, images and animations should where possible exclude any contents of a visceral nature. Images of victims should be replaced with human figures to avoid shock to the viewer.

Such caution in the use CG displays has been shown in the case of *People V Mitchell*. Convicted for the murder of his brother despite claims that he acted in self-defence, the prosecution used CG illustration to show that it was not possible for threatening gestures made by the victim to be seen behind the wall that the defendant stood. Upon defence counsel’s objections, the CG display was ordered to be changed several times; ultimately replacing the human like figure with geometric shape to avoid the risk that the jury might assume as proven fact the position of deceased’s hands in the illustration [Selbak, 1994]. Another high profile case where bias was an issue was the *O.J. Simpson* case. Desire to make the CG evidence as realistic as possible, the true skin colour was shown. However, this was decided too be too suggestive in that the person committing the crime was portrayed as being black and may bring unfair bias to the case [Narayana, 2001].

The interactive nature of CG displays is a major advantage of this type of presentation. However, misuse of this can introduce bias in the proceedings. This was shown in the *Rodney King* murder case where the video portraying the beating was played slowly to de-emphasise the brutality of the event. By speeding up, slowing down or showing the animation from a particular viewpoint, the court may be led to believe something happened in a way that may be slightly or even greatly removed from the facts [Narayana, 2001].

There is no doubt that CG displays are a powerful tool of persuasion in the armoury of any technologically adept litigator who is prepared to use them. Nevertheless, some commentators have expressed considerable unease about the use of such technology in the courtroom. The consequences of misuse of CG displays cannot be underestimated particularly in the context of a criminal trial where as one writer has noted: “Rather than an award or loss of money judgement, the defendant in a criminal prosecution is subject to a loss of liberty” (Bardelli, 1994) [O’Flaherty, 1996].

Lighting conditions within a scene has always presented a problem to SOCO’s when recording a scene as it was found. This can directly affect the way that a viewer perceives a scene presenting a possibility of bias to the viewer. In scenes where there is low level ambient lighting, an optical system can experience difficulties in capturing the details of a scene and vital information may be lost. However, the introduction of artificial lighting such as a flash or external lighting can also be problematic; essentially changing the conditions of the scene by the addition of shadows or the alterations of colour temperature. This can be used as persuasive tool causing viewers to associate a scene such as a dark alley with a warmer gentle scene through manipulation of lighting and colour settings. Therefore, care must be taken to avoid unnecessary tampering of lighting conditions within a scene.

#### **3.5.2.4 Manipulation or Enhancement**

During the course of a criminal proceeding it may be necessary to utilise computer techniques to enhance an image in order to increase its clarity. However, due to the ease with which digital images can be edited and manipulated with commercially available software packages, there is much concern regarding its use within the law enforcement community. Herb Blitzer, executive director of the Institute for Forensic Imaging says “Its widespread use makes digital imaging suspect in the courtroom, but such images are really no more suspect than any image shown in a modern courtroom” [Biehl, 1999]. The use of digital images for evidential purposes opens up many questions regarding its use for evidential purposes. What represents justifiable enhancement? Does this differ from manipulation which might have, or be perceived to have, malicious intent, and where can the distinction be drawn? [House of Lords, 1998].

Image enhancement is done solely with the intent to clarify existing information; nothing is added to the image. Generally, image enhancement techniques have direct counterparts in traditional silver-based darkrooms. These include brightness and contrast adjustment, colour balancing, cropping, and dodging and burning which are acceptable forensic techniques [SWGIT, 2003]. Non-traditional image enhancement techniques that are limited to computers such as colour processing, linear filtering, nonlinear contrast adjustments, pattern noise reduction, and random noise reduction are only recently being applied within the forensic environment [SWGIT, 2003]. Manipulation, on the other hand is defined as “to change by artful or unfair means so as to serve one’s purpose.” [Azcarate, 2000]. Any alterations which affect the image data, no matter how innocuous, should be treated with caution [House of Lords, 1998].

It is not always immediately clear what constitutes enhancement and what may verge into the area of improper manipulation that can distort or introduce information [Russ, 2001]. The person submitting the images as evidence must explain what the image is a picture of, why it is relevant, how it was acquired, how it came to be in court and what it implies.” [Biehl, 1999]. Acceptance of enhanced images ultimately falls on the judge’s discretion. In the double homicide case of *State of California v Phillip Lee Jackson*, the defence requested for a Frye hearing † on the admissibility on the digitally enhanced fingerprint image. However, the court ruled this unnecessary on the argument that digital processing is a readily accepted practice in forensics and that new information was not added to the image [Staggs, 2001].

† **Frye Hearing** – Used in the U.S, the Frye hearing examines whether the evidence being submitted has gained general acceptance in the particular field in which it belongs.

The relatively new nature of digital imaging within the legal system combined with increase exposure in the form of television shows has allowed the potential for claims of image manipulation to be quite effective; especially when the chain of custody is poorly documented [Berg, 2000]. Developing and following Standard Operating Procedures (SOP) to document the whole process of enhancement ensures that each of the steps are logged so that the results can be duplicated if needed and should preclude the question of whether a photograph was digitally enhanced with the intent to falsify information [Advanced Imaging and Analysis, 1999].

An issue of manipulation was raised in a 1995 murder trial in Seattle. A digitally enhanced palm print was the only conclusive evidence that tied the defendant, Eric Hayden to the crime scene. Questions regarding the ability of the computer to make arbitrary changes to an image without the knowledge or consent of the operator were raised. The defence also implied that deliberate changes could have been made to the image, by the operator, which resulted in a false identification [Berg, 2000].

### **3.6 Admissibility of Computer-Generated Evidence in the Courtroom**

The merging of traditional forensic science with computers has created its own set of complications within the legal system. Although a digital photograph may be cosmetically identical to a conventional photograph, its very qualities inherent in digital data present an entirely different species of evidence [McCarvel, 1995].

Existing rules of evidence are constantly being challenged by the applications of novel technology such as digital photography. All forms of evidence can raise questions of authenticity; digital images are not unique in this respect [House of Lords, 1998]. The fact that digital photographs are more easily altered than film-based photograph is usually cited [Staggs, 2003]. With the growing awareness to the ease by which a digital image can be altered, courts will have to establish procedures to assure the accuracy and integrity of digital visual evidence admitted into legal proceedings. It is inevitable there will be challenges to its admissibility in court and new guidelines will have to be drawn up to address the issues. The laws that deal with the admissibility of digital displays as

evidence differ somewhat from country to country. Due to the extensive use in the US, the laws governing the use of digital images are more developed than then UK.

### **3.6.1 USA**

In order to prevent potential bias and unfairness, CG displays must pass through a set of criteria before being admitted as evidence in US courts. Evidence can be of two types: demonstrative or substantive. Demonstrative evidence is used for its explanatory value and serves only as a visual aid. Substantive evidence on the other hand possesses probative value that is used to prove a fact. Depending on the type of evidence, a set of criteria must be met for its admissibility in court. Ultimately it falls to the trial judge's discretion to decide upon whether the distinction of the type of evidence made by the counsels submitting the evidence is correct.

#### **3.6.1.1 Admissibility of Demonstrative Evidence**

Demonstrative evidence is used only to illustrate an expert's testimony and is considered to have no probative value. The standard test for its admissibility is relevancy. Council admitting demonstrative evidence must show that the evidence has a logical tendency to make the existence of any fact of consequence to the action more or less probable than without the evidence [Bardelli, 1994].

A principal case concerning the admissibility of CG evidence as demonstrative evidence is the case of *People v. McHugh*. The defendant sought to introduce a computer re-enactment illustrating his alternative theory of the car crash incident. The court found the CG display to be admissible on the theory that it was more akin to a chart or diagram than scientific evidence, thus the stringent pre-trial hearing that is required of substantive evidence was not necessary [Borelli, 1996]. Whether a diagram is hand drawn or mechanically drawn by means of a computer is of no importance [Bardelli, 1994].

### **3.6.1.2 Admissibility of Substantive Evidence**

Due to nature of substantive evidence, they are subject to more stringent standards and greater scrutiny than the evidence submitted solely for demonstrative purposes. Both Frye and the Federal Rules of Evidence standards apply to substantive evidence.

#### **3.6.1.2.1 The Frye Test**

In 1923, a landmark decision in the case of *Frye v. United States* defined the basic prerequisite for admitting scientific evidence. The case considered the use of a systolic blood pressure analysis, the precursor to the polygraph test, in a criminal case. Although the attempt to admit this technique failed, the principle on the general scientific acceptance articulated during the course of the case opened up the door for numerous admittance of scientific evidence within the US court system [Matson, 2004].

The principle of the 'Frye test', examines whether the evidence being submitted has "gained general acceptance in the particular field in which it belongs" [Berg, 2000]. However, it is not enough simply for a few experts to approve of a scientific technique. Under Frye, the technique must be generally accepted by the relevant scientific community [Bardelli, 1994]. This standard governed the admissibility of scientific evidence over the next seventy years.

There have been a few cases that refer specifically to the challenges made to the use of digital images as evidence. The case of *State of Florida v Victor Ryes* where the defence requested a Frye hearing on the admissibility of a digital image of a palm print that was put through a series of enhancement techniques. The state presented testimony of two further experts to demonstrate that the use of digital imaging to enhance a latent print is not new, and that it is accepted within the relevant forensic community. This is supported by the International Association for Identification (IAI) which states "that electronic/digital imaging is a scientifically valid and proven technology for recording, enhancing, and printing images and like conventional silver-halide based photography, it is accepted by professional commercial photographers, law enforcement photographers, and identification community" [Knoerlein, Accessed 2006].



Despite the wide use of the 'Frye test', there has been much criticism of the strictness of this standard and the difficulty in defining the 'relevant scientific community' to which the technique belongs as many scientific application do not fall squarely within any one scientific field. This has let many courts to shift away from its use.

### **3.6.1.2.2 Federal Rules of Evidence**

Although the Frye test standard is still applicable in about half of the states, another rule started to take precedent in 1993. The civil case of *Daubert v. Merrill Dow Pharmaceuticals*, considered claims by the plaintiffs that the ingestion of the prescription anti-nausea drug Bendectin, widely taken in the 1960s and 1970s by pregnant women with morning sickness was the cause of children's serious limb defects. The court in this case, for the first time, rejected Frye as the sole standard for the admissibility of scientific evidence, announcing Federal Rules of Evidence (FRE) as the new standard. Essentially, Frye's general acceptance test was superseded by the FRE adoption. Since that time, a number of state courts have also adopted FRE as the standard they use for determining the admissibility of scientific testimony [Berg, 2000].

The admissibility of scientific evidence through the FRE is concerned with three requirements: relevancy, authentication and procedural requirements which are finally decided upon by the trial judge.

The root of the FRE test is its relevancy requirement and under rule 40, states that relevant evidence is evidence which has "any tendency to make the existence of any fact that is of consequence to the determination of the action more probable or less probable than it would be without the evidence" [Bardelli, 1994]. The inclusion of FRE 403 which states "although relevant, evidence may be excluded if its probative value is substantially outweighed by the danger of unfair prejudice, confusion of the issues, or misleading the jury, or by considerations of undue delay, waste of time or needless presentation of cumulative evidence" [Bardelli, 1994]. Once relevancy has been determined, under the FRE the reliability of the evidence admitted must be determined by the trial judge.

In addition to requirement of relevancy, the FRE requires authenticity standards to be met. The FRE rule 901(a) simply states that: “The requirement of authentication or identification as a condition precedent to admissibility is satisfied by evidence sufficient to support a finding that the matter in question is what its proponent claims” [Bardelli, 1994]. Adhering to this rule with CG in mind, the advocate should be able to explain the procedures used to input the data, and reveal tests used to assure the accuracy and reliability of this data.

Under the FRE approach, procedural requirements are also considered. These include: first, qualification of the expert; second, adequate cross-examination of the expert; third, careful jury instructions as to evaluation of the expert testimony; and fourth the exchange of all relevant data before trial [Bardelli, 1994].

### **3.6.2 UK**

Although the application of digital displays has only recently started appearing in UK courts, relevant case law from the US and other jurisdictions may be referenced for admissibility requirements [Schofield, 2002]. In the UK, laws governing evidence are separate in civil and criminal courts. Although, there is no legislation in the UK which specifically covers the use of digital images as evidence, there exists a significant portion of the law which deals with technological recording which would equally apply to digital images.

The rules of evidence of common law jurisdictions exclude certain types of document such as ‘hearsay’ which are generally not admissible as evidence. However, information captured through the use of recording devices such as cameras involve no human intervention and as such is not normally classed as hearsay thus can be admitted in evidence [House of Lords, 1998].

#### **3.6.2.1 Civil Legislation**

In civil litigations, there are no prior requirements which must be met before a document which includes digital images can be admitted in evidence [House of Lords, 1998]. Section 1 of the Civil Evidence Act 1995 abolishes the hearsay rule for civil proceedings. It states [Swarb, Accessed 2006]:

- 1) In civil proceedings evidence shall not be excluded on the grounds that it is hearsay.
- 2) In this Act –
  - a. “Hearsay” means a statement otherwise than by a person while giving oral evidence in the proceedings which is intended as evidence of the matters stated; and
  - b. References to hearsay include hearsay of whatever degree.

Section 8 provides that prove of a document can be in the form of a copy, even if the original is still in existence and that it is irrelevant how number of removes between a copy and the original [House of Lord, 1998].

The introduction of the Civil Procedure Rules (CPR) has bestowed addition powers to judges to control the preparation for and during a trial. Section 32(1) of the deals with the power of court to control evidence, and states [DCA, Accessed 2006]:

- 1) The court may control the evidence by giving directions as to -
  - a) the issues on which it requires evidence;
  - b) the nature of the evidence which it requires to decide those issues; and
  - c) the way in which the evidence is to be placed before the court.
- 2) The court may use its power under this rule to exclude evidence that would otherwise be admissible.
- 3) The court may limit cross-examination.

### **3.6.2.2 Criminal Legislation**

In criminal cases, computer output is only admissible in evidence where special conditions are satisfied. These conditions are set out in detail in section 69 of the Police and Criminal Evidence Act (PACE) 1984. Section 69 states that computer records are admissible as evidence if they can verify to their accuracy. Specifically, any party relying on computer evidence has to provide oral or written certification of the reliability of the computer; stating that either the computer system was at all times

operating properly, or that any defect in its operation was not such as to affect the accuracy of the record [House of Lords, 1998].

Section 69 of PACE provides that [House of Lords, 1998]:

- 1) In any proceedings, a statement in a document produced by a computer shall not be admissible as evidence of any fact stated therein unless it is shown:
  - (a) That there are no reasonable grounds for believing that the statement is inaccurate because of improper use of the computer;
  - (b) That at all times the computer was operating properly, or if not that any respect in which it was not operating properly or was out of operation was not such as to affect the production of the document or the accuracy of its contents; and
  - (c) That any relevant conditions specified in rules of court under subsection (2) below are satisfied.

2) Provision may be made by rules of court requiring that in any proceedings where it is desired to give a statement in evidence by virtue of this section such information concerning the statement as may be required by the rules shall be provided in such form and at such time as may be required.

Printout from a computer which records information automatically without human intervention is admissible as real evidence and therefore involves no question of hearsay. However, printout where information has been supplied to the computer by a person it is hearsay but may be admissible under section 23 or 24 of the Criminal Justice Act 1988. A statement can only be admitted under section 23 or 24 if its maker had reasonably supposed to have had personal knowledge of the matters dealt with. A statement in a computer printout which has satisfied the foundation requirements of section 23 or 24 can only be admitted on satisfaction of the additional requirements contained in section 69. The object of section 69 is to impose a duty on anyone who wishes to introduce a document produced by a computer to show that it is safe to rely on

that document and it makes no difference whether the computer document has been produced with or without the input of information provided by the human mind and thus may or may not be hearsay [Hoey, 1996].

The repeal of section 69 of PACE by The Law Commission stated the impracticality to “certifying all the intricacies of computer operation and experience showed that most computer error was either easy to detect immediately or had resulted from human error in data entry rather than from malfunction”. In the absence of Section 69, a presumption of proper functioning would be applied to computers [House of Lords, 1998].

### **3.7 Standard Operating procedures**

The concerns associated with the use of digital displays such as the integrity of digital evidence can largely be addressed by employment of SOP. This will aid the acceptance and development in the use of digital images.

Failure to establish adequate SOP may render any evidence collected worthless. This was evident in the March 2004 Madrid bombing on a commuter train which killed 191 people. Spanish authorities submitted to the FBI for analysis a partial latent fingerprints obtained from plastic bags that contained detonator caps. A comprehensive search revealed prints that were subsequently linked to Brandon Mayfield [FBI Press Room, 2004]. He was jailed for 17 days after which the case was dropped and he was released following concerns regarding the accuracy of the identification made by the FBI and further review was required. It was determined that the FBI identification was based on substandard quality digital copy images of the original leading to the false identification of Brandon Mayfield. A senior FBI official said that the use of a copy of the fingerprint, rather than the original, was allowed by lab guidelines. “It was absolutely acceptable to examine a digital image,” the official said. But the official said that the question of how and when copies should be used will be reviewed by the bureau in light of the Mayfield episode [The New York Times, 2004].

The UK Police Scientific Development Branch (PSDB) published the ‘Digital Imaging Procedure’ in March 2002 which details the procedures involved in the proper capture,

handing, achieving and securing of digital images for law enforcement involved throughout all stages of the Criminal Justice System. This is intended as a guideline that individual companies or constabulary can use in order to develop their own SOP. SOP can be divided into four stages: Preparation, Capture, Protection and use as illustrated in Figure 3.15.

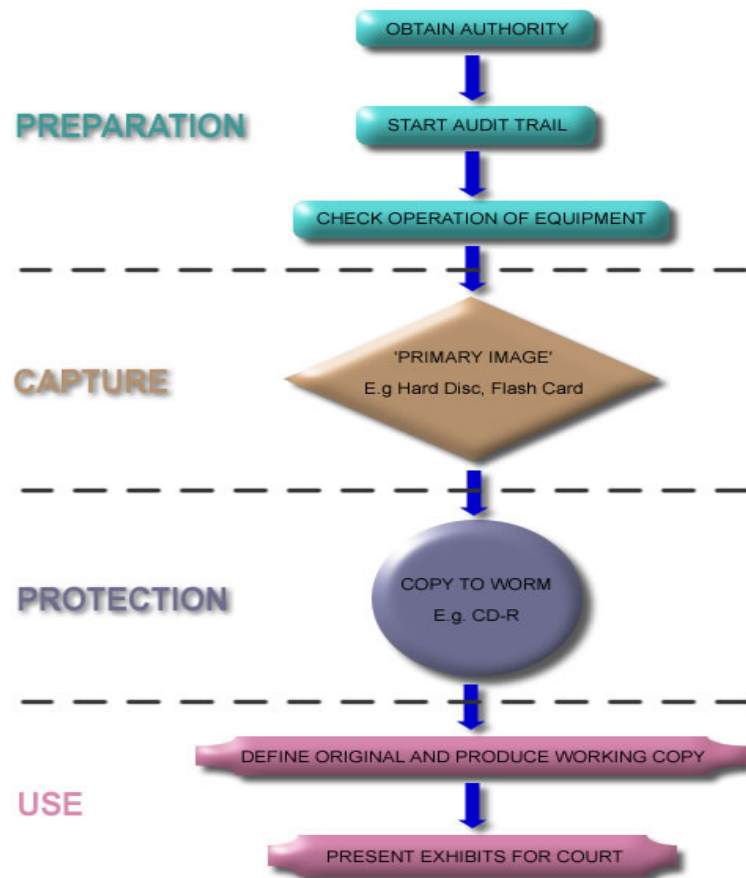

**Figure 3.15** – Recommended Steps for Standard Operating Procedures.

### 3.7.1 Preparation

The preparation stage of the SOP involves steps to be taken before images are captured. This involves obtaining relevant authorisation and starting an audit trail at the earliest opportunity in order to help safeguard the integrity of the images captured. Although, very much similar to taking notes for the general documentation of the crime scene, additional information should be included such as [PSDB, 2002]:

- The creation and defining of the Original;
- The storage of the Original;
- Any access to the Original;
- Disposal

Another step essential in the preparation stage is to ensure that the operation of any equipment and software employed is functioning properly. This allows the output images to avoid question of inaccuracy due to computer error.

### **3.7.2 Capture**

The capture stage covers the capture of images and its transfer onto the chosen medium, taking into consideration the quality and integrity of the images. Generally digital still camera can be used in the same ways as conventional cameras. However, due to its digital nature, they possess a few differences. The image quality of the settings on the digital camera should be as such to be adequate to the operational requirements rather than to minimise storage capacity. The ability of digital cameras to delete images should be addressed. During the course of the investigation, any images taken whether clear or not should not be deleted without authority. Any deletion of images may result in legal challenge during any prosecution.

Initial acquisition of image from the digital camera to the removable medium; i.e. flash card is known as the 'primary' image (Figure 3.16). Due to the nature of the storage medium, the images captured are susceptible to image tampering and should therefore progress to the protection stage as soon as possible.

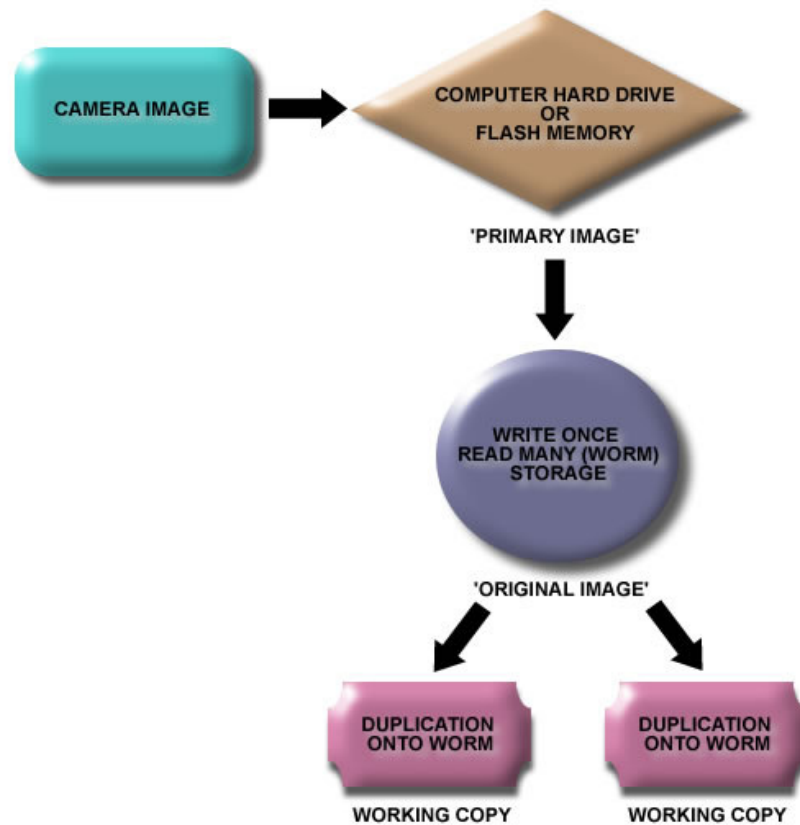

**Figure 3.16** – Defining Stages of Image Transfer.

### 3.7.3 Protection

The protection stage involves transferring the ‘primary’ images to a non-reusable medium in order to protect the images and reduce the opportunities for challenges at court. Non-reusable ‘write once read many times’ (WORM) media such as CDs, DVDs are ideal, in that once closed the recording on the disc cannot be altered.

Digital technology offers new challenges for authentication and, at the same time, technology can be employed to meet those concerns [McCarvel, 1995]. The use of authentication techniques such as watermarking and encryption allow for the reliability of evidence to be established and aid in detecting any intentional or unintentional alterations to the images.

### 3.7.4 Use

The images transferred to the WORM media is defined as the ‘Master’ or ‘Original’ through from which all subsequent working copies are duplicated from. Working copy



is the version that will be used for investigation and to assist in the preparation of the prosecution file (Figure 3.16). Since a copy of a digital image file is a bit for bit identical copy, the working copy is the same and will have the same evidential weight [PSDB, 2002]. The Master copy is stored securely and is only viewed upon doubt to the integrity of the images.

### **3.8 Technology in the Courtroom**

The success of CG displays in the courtrooms will largely depend on its ability to accommodate such technology. Courtroom and chamber technology encompasses any technology built into the court that aid in communication and presentation of evidence. Unless courts are adequately equipped to present the CG displays, there will be little value in its use. This technological capability has been largely absent in courtroom but is now beginning to change [Lederer, 1994b].

Leading the way in the advancement in courtroom technology has been the US. US company such as 'Doar Litigation Consultancy' offers expertise in setting up courts with high-tech visual systems. It is estimated that they have helped equip over 500 courtrooms with technological capability [Doar, Accessed 2006]. Of 1366 courtroom in US district courts, 363 have laptop computer wiring and 370 have some form of computer monitor displays for the jury [Wiggins, 2003]. In order to increase the use of technology, the Judicial Conference of the US in March 1999, approved recommendation to endorse the use of technologies in the courtroom. Subject to available funds, recommendation consisted of including video evidence presentation systems into existing courtrooms [Wiggins, 2003].

Technology for the sake of technology is an inappropriate use and results in waste of money and human resources. In 1993, saw the unveiling of Courtroom 21, the most technologically advanced courtroom in the US. This courtroom serves not only as an international model of integrated mainstream, commercially available technology but also as an experimental test bed for various techniques [Lederer, 1994b]. Courtroom 21 project provides all that are concerned with courtroom activities with a functional model courtroom where the technology can be examined and scrutinised and debated in order

to determine if the technology meets their needs. The model courtroom is continuing changing and helps bring these new innovations to the mainstream.

### **3.9 IBVR and Forensic Science**

The use of GBVR within a forensic context has been well documented. However, with the arrival of IBVR in recent years, the forensic community has begun to realise the potential of such technology. A need to improve the ability to present complex physical evidence located at major crimes scenes was recognised by the Queensland Police Service (QPS) in Australia. In 1997, the Interactive Crime Scene Recording System (ICSRS) was developed by QPS as an additional tool to aid police investigators [Morley, 2002]. The procedure involves using a camera mounted tripod adapted for taking ICSRS images much like the standard camera (single-row) technique outlined in subsection (3.4.3.1), and capturing a full set of 360 degree photos [Rutledge, Accessed 2006]. These images are then electronically stitched to create a virtual view allowing viewers to move around the scene at their own pace. At the time of implementing of the ICSRS, the QPS was the first jurisdiction in Australia to use this technology in the investigation of crime, and the first at an international level to use the technology in the courtroom [Morley, 2002]. Application of the ICSRS in court proceedings has been successful and since its introduction, the ICSRS has been adopted by the South Australian and New South Wales Police Services [Rutledge, Accessed 2006].

IBVR's ability to provide a cost effective method of training and assessment has led the National Institute of Forensic Science together with the combined police services in Australia to develop 'After the Fact' [NIFS, 2002]. This is CD-ROM based, consisting of a series of interactive multimedia training and assessment programs. Using panoramic techniques, the program creates a virtual crime scene which allows investigators to obtain the necessary skills for crime scene investigations without the necessity for creating expensive and time consuming mock ups of scenes.

A recent emerging system which has the potential to revolutionise the way that law and forensic communities document crime scenes is the 'Return to Scene' (R2S) system. Created by an Aberdeen based technology company, MaxIMT, in collaboration with

Grampian Police, provides a simple yet high quality system for capturing a 360 degree IBVR scene. This system utilises the latest technology through a Spheron High Dynamic Range camera (discussed in Chapter 3.4.3.4) which possess a 26 f-stop dynamic range and captures images with a 50 mega pixel resolution and 48 bit colour depth per pixel [MaxIMT, Accessed 2006]. This produces a high quality VE with the ability to enhance areas which are difficult to see, bringing over exposed or under exposed areas back into view. This is one of the main vantage points of using a Spheron camera as oppose to a normal digital camera which only allows variation of the contrast and brightness of the images. Additional differences compared to the use of normal digital camera lies in the way the images are captured. Instead of capturing a series of images, the Spheron camera scans vertical strips of the room while rotating. Through R2S's unique software application, the VE is then displayed in real time, eliminating the need to stitch the images together. This highly sophisticated system provides an additional tool for police and forensic investigators. Due to the high price associated with each system, it use is limited to only the highest profile cases.

### **3.10 Summary**

This chapter has provided the necessary background knowledge that relates to the main context of the thesis. By first introducing the three types of crime scene documentation techniques; notes, photography and sketches employed by today's law enforcements, it provided an insight to the area of contribution that the thesis can make. A basic knowledge of digital photography technology provides an overview of the advantages that this technology can bring to the law enforcement community. These have to do primarily with the digital recording of the data, which permits duplication, transmission, and storage of the image without any degradation of quality. The chapter provided an in-depth account of the types and methods for creating VEs. The thesis then identified the current application and acceptance of CG displays within the US and UK including their admissibility within the courtroom.

## **Chapter 4: CASE STUDIES †**

### **4.1 Introduction**

As discussed in Chapter 3, the application of CG displays has been relatively new, particularly within the UK. The increasing need to communicate complex data in layman's language is bringing about a change in the viewpoint of forensic scientist towards the use of CG displays as a method of presenting evidence. Jurors are easily confused by technical explanations, placing more credibility upon what they can see and touch [Berg, 2000].

Communication of forensic data in court using traditional visual aids was considered inadequate by the forensic scientists, whom sought more effective methods. This chapter presents four case studies which in collaboration with forensic scientist from FA, resulted in the construction of CG displays to convey complex forensic information for use in court. Through these case studies, lessons can be learnt as to the best possible method of creating an effective CG presentation.

### **4.2 Case Study 1**

This case, headed by Tiernan Coyle from FA, is the first one-to-one (1:1) taping case in the UK. In collaboration with Thames Valley Police (TVP) force, this case hopes to serve as a milestone to the potential benefits of the 1:1 taping technique. Originating from Germany, 1:1 taping has not gained widespread use due to the burden that the technique places on resources. The area of taping defines the exact position of the fibres on the surface which indicates the type and extent of the contact that caused the fibre transfer. "It is unlikely that fibres cluster together in numbers on surfaces by chance; the relative frequency of their occurrence in the general population at large becomes far less probative than their distribution on the surface in question" [Coyle, 2004]. Conventional methods of fibre comparison would usually do little more than provide evidence which was suggestive of contact between two materials. They provide little, if any, assistance as to the nature and extent of the contact which had occurred.

† Cases undertaken by the author on part of his PhD research.

#### 4.2.1 The Case

The body of a deceased man was discovered lying on his back on the lounge floor in his own house. Subsequent post mortem concluded that the victim had bled to death through severing of the left common carotid artery and left internal jugular vein.

On arrival of the police, a new technique, 1:1 taping was employed. Although, the technique generally requires that both the front and back be taped, due to the presence of wet blood, a decision to tape only the front of the body was made. Seventy six tapings were taken from the body of the deceased with the position of the strips recorded by photography. However, two of these tapings could not be assigned to specific area of the body despite the presence of photographs, thus are not examinable.

Subsequently, a bag containing a red bloodstained hooded top and black tracksuit bottoms were discovered nine days after the murder by a member of public in the woods. These were submitted to the laboratory for further analysis. Figure 4.1 presents photographs of the suspect's clothes used in the analysis and comparison of the fibres.



**Figure 4.1** - Photographs of the Suspect's Clothing [Coyle, 2002].

Following information received by the police, a suspect was arrested. Although, initially denying any involvement, the suspect was interviewed five times; his story changing on each subsequent interview. Due to the mounting evidence against the suspect, he stated that the clothing must have been stolen from his caravan by someone and worn to carry out the attack before abandoning it in the woods.

### 4.2.2 Requirements of the Case

Concerns were voiced regarding the best possible way to illustrate the findings of the fibre evidence in court. Analysis revealed heavy and prolonged contact between the suspect and victim. In particular, areas of high number of matching fibres on the victim suggested that the suspect had sat astride the victim's chest with his weight distributed to the left hand side while leaning forward; essentially pinning the victim down. It is the requirement of the presentation to present the conclusion of this fibre evidence in a clear and logical manner using CG methods.

Displaying this information in the form of tables, would remove the ability to visualise the patterns that allow the jury to grasp the full details that the 1:1 technique is exhibiting. Therefore, a graphical representation is required to accurately show the distribution of fibres on the surface of the victim in relation to the fibres from the suspects' clothes.

### 4.2.3 Presentation

Accounting for 3.8% in the world, the UK has 35,807,929 internet users as estimated in June 2005 [e-consultancy, Accessed 2006]. The decision to utilise web-based technology results from this familiarity with the internet and its software. This gives a user friendly platform in which to demonstrate the evidence. The presentation, consisting of four main sections is linked together using hyperlinks and hotspots, providing an interactive presentation in which the expert witness can illustrate and explain the evidence of the case in any order.



The first section as illustrated in Figure 4.2 presents the total number of fibres transferred from suspect to victim and vice versa. In order to avoid sympathy towards the victim and therefore bias that can be introduced with the use of scene photographs, a graphical representation of the victim and suspect are used in this section. The colours and patterns of clothing worn during the alleged attack are represented as closely as possible. Total transfer of fibres is represented by a figure and an arrow indicating the direction of transfer.

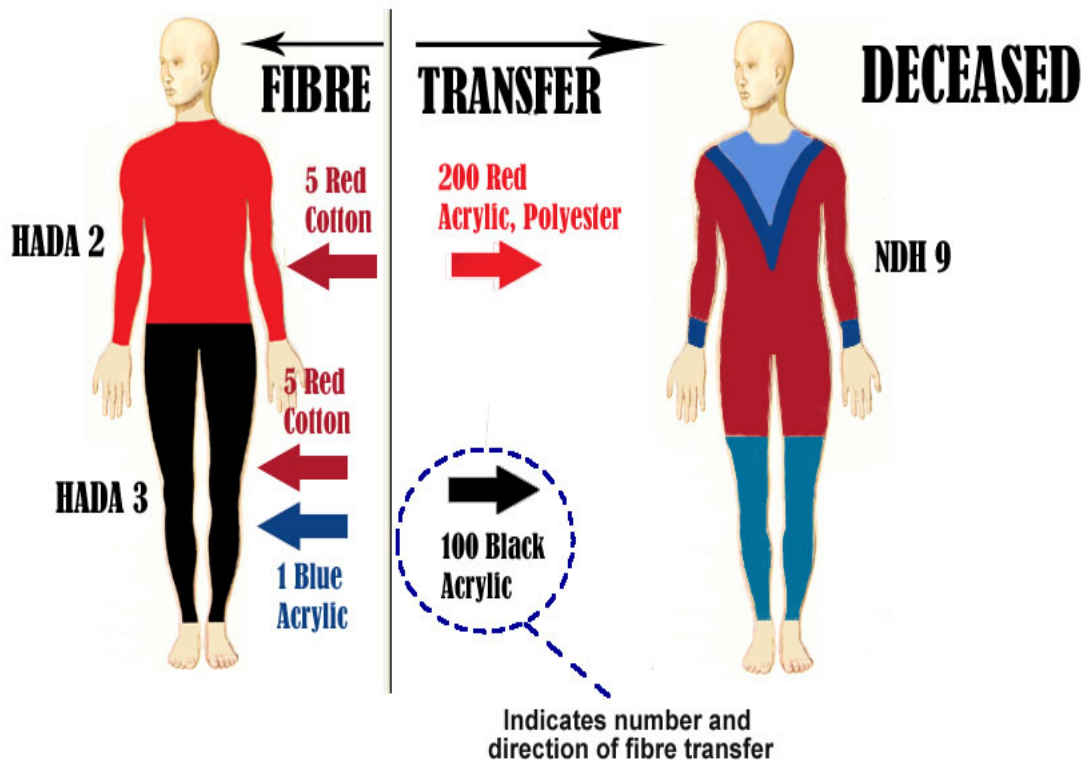

**Figure 4.2** – Transfer of Fibres from Suspect to Victim and Vice Versa.

The second section of the presentation gives a more detailed representation of the fibre transfer by relating the number of red and black fibres found on each taping to the position that the taping were placed on the surface of the deceased. Additionally, by illustrating the red and black fibres separately, it helps demonstrate not only the extent of the contact but which part of the suspect was in contact. Regions representing the area that the taping was placed on the body were marked out on the representing image of the victim and numbered accordingly based on the photographic evidence. The number of fibres matched to the suspect's clothing were grouped into several categories, colour coded and superimposed onto the image accordingly. A darker shade of colour represents groups with greater number of fibres transferred. By colour coding the groups of fibres and superimposing onto the image as illustrated in Figure 4.3, a quick visualisation of the level and area of contact that each piece of clothing of the suspect had with the victim was made possible.

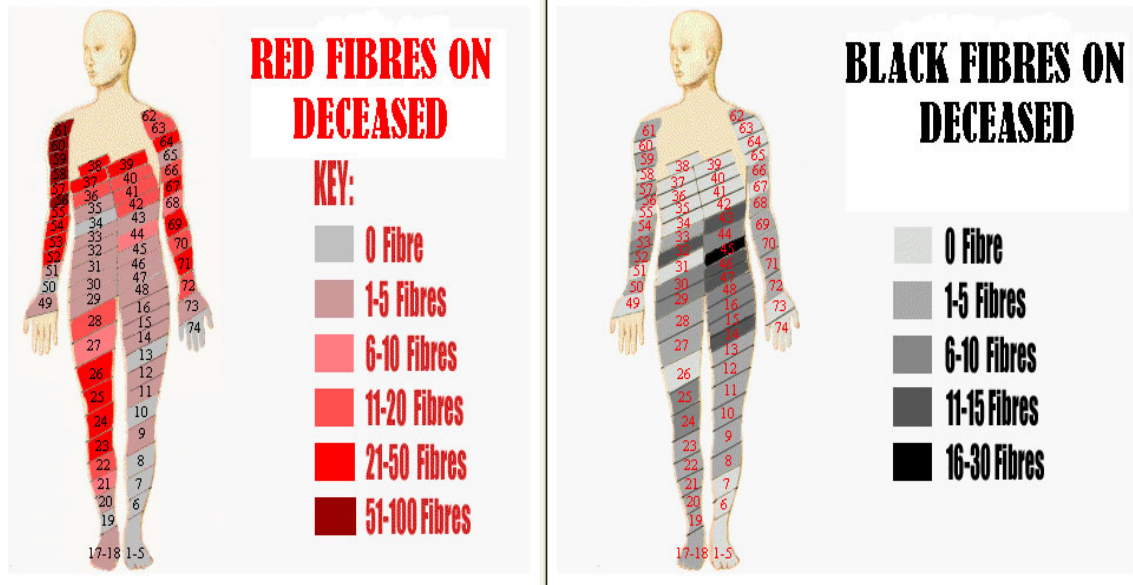

**Figure 4.3** – Transfer of Red and Black Fibres onto the Deceased.

To provide an increase sense of accuracy, realism and flexibility, scene photographs were integrated into the presentation. A series of photographs were chosen to represent all seventy four tapings. Using colour shape indicators, each significant fibre found on the tapings are represented by an individual indicator and superimposed onto the scene photographs in the area that the taping was taken as presented in Figure 4.4.

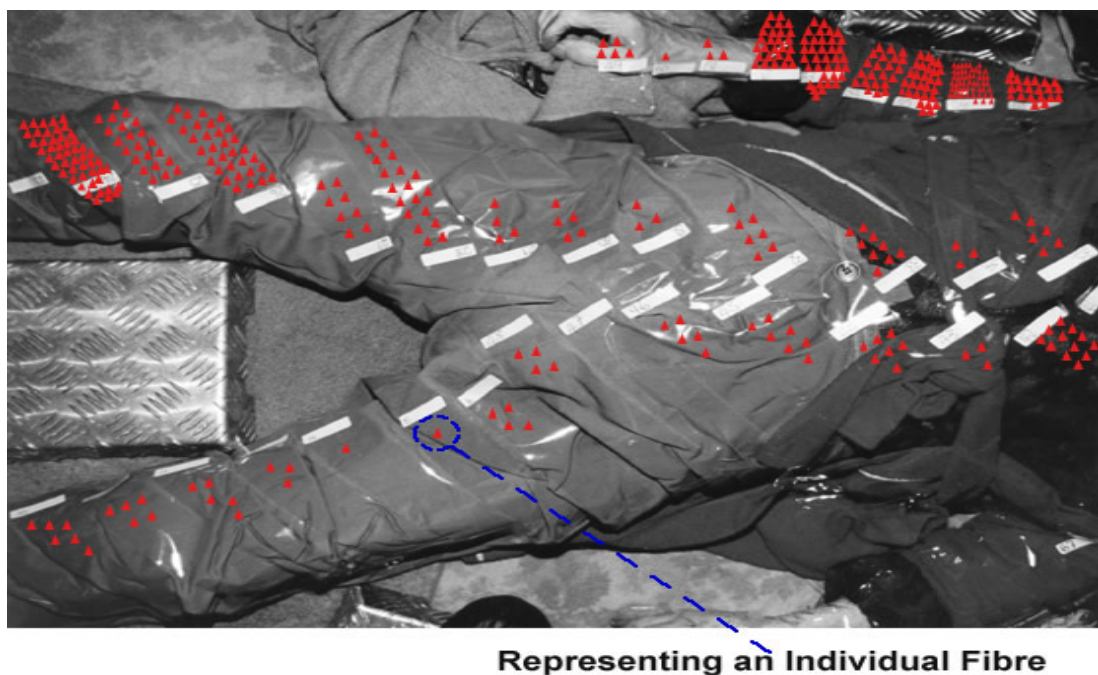

**Figure 4.4** – Representation of Individual Red Fibre Transfer on Scene Photographs.



Illustrated in Figure 4.5, hotspots were superimposed over the same scene photographs used to represent the individual transfer of fibres. By clicking on the area of taping within the photographs, the corresponding image of the taping are displayed. This allows the expert witness to describe the transfer of fibres and method of examination with reference to the tapings.

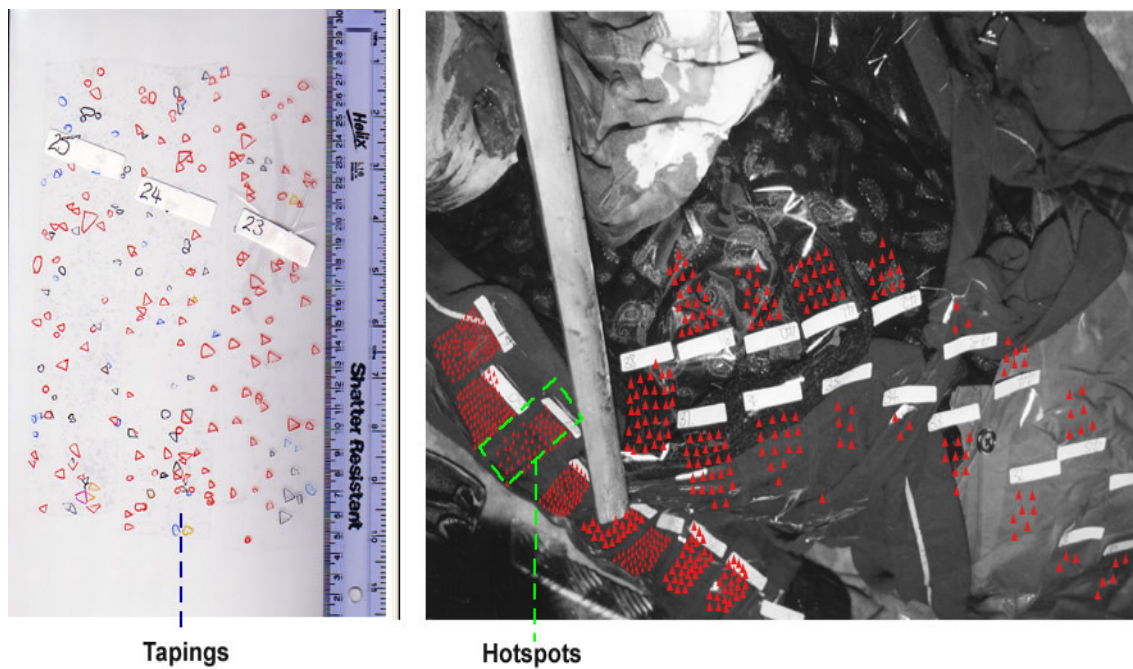

**Figure 4.5** – Illustration of Tapings through Activation of Hotspots.

#### 4.2.4 The Trial

The Oxford Crown Court where the trial was held did not possess the necessary equipment to display the CG presentation. As a result, the expert brought his own equipment which consisted of a laptop, projector and projector screen. To enable the presentation to be seen clearly, the projector screen was positioned behind the expert in clear view of both the judge and jury.

A decision to employ a combination of a ‘jury pack’ consisting of a collection of photographs along with the CG presentation allows the jury to easily recollect on the evidence presented to them before reaching a decision on the verdict.

With the overwhelming evidence against the suspect, he was found guilty and charged with murder. The presiding judge commended the effectiveness of the fibre evidence along with the CG presentation which was described as both fascinating and compelling [Coyle, 2004].

#### **4.2.5 Conclusion**

This case study provided a framework for all subsequent case studies within this thesis. During the course of construction, there were a number of alterations to the presentation that were requested by the defence team before trial.

These changes involved excluding the use of names which were originally used to indicate the images of the suspect and victim. However, forensic testimony should be impartial and as such any details that personalises the presentation should involve careful consideration and only used if absolutely necessary. The names were subsequently removed and ‘suspect’ and ‘victim’ used in its place.

Concerns regarding the use of real scene photographs in the presentation also arose following discussions between the forensic expert and TVP. It was their concern that the use of scene photographs would introduce a shock factor upon the jury viewing it and ultimately be rejected in court. Therefore in preparation of the presentation for use in court, two versions were produced; a full version and another one with the scene photographs removed. The full version was ultimately used during the trial but it demonstrates the possible concerns and challenges that the use of CG displays may bring.

#### **4.3 Case Study 2**

This case headed by Pam Hamer from FA is concerned with shoeprints marks. A shoeprint is unique due to its many variables: length of wear, random marks and scratches and the design on a particular sole. This allows shoeprint marks left at a scene to be matched to their corresponding shoe and thus user.

#### **4.3.1 The Case**

A man was found and reported dead in his own house by neighbours. Subsequent post mortem revealed extensive bruising on the body, indicating that the deceased had suffered a period of prolonged beating. Death had resulted from a multiple of injuries, particularly trauma to the head and chest caused by kicking and stamping. Three men were present at the scene when the deceased was found; two of which were brothers of the deceased. Although, all accepted that they were present at the time of the attack, they deny any knowledge of his death. Shoeprints from the three men were acquired for the subsequent investigation.

All three men and the deceased appeared to be alcoholics and were in the habit of getting drunk and beating each other up. The statement given by one of the men suggests that the two brothers were the main attackers although the account was unreliable due to the drunken state of the suspects.

#### **4.3.2 Requirements of the Case**

The bruising left on both the front and back of the victim's body indicated the present of three sets of shoeprints marks relating to the three suspects. Explaining the direction and orientation of each shoeprint marks in relation to the victim presented a difficult task to the forensic expert. This is further exacerbated by the presence of three types of shoeprints marks, many of which are superimposed over each other. Attempts to produce an effective means of conveying this information to the jury can be seen in Figure 4.6. This diagram utilises arrows on a simple drawing of a body to illustrate the position, direction and type of shoeprint on the deceased. Although this gives a quick visual view of the position of the bruising; understanding the orientation and type of shoeprint is more complex. CG presentation provides a powerful alternative in which to convey this information.

The CG presentation aim to demonstrate the evidence in a simple yet effective way by keeping the details of evidence and graphical presentation down to a minimum. This is to avoid unnecessary cluttering of information and to concentrate the jury's attention on the relevant information.

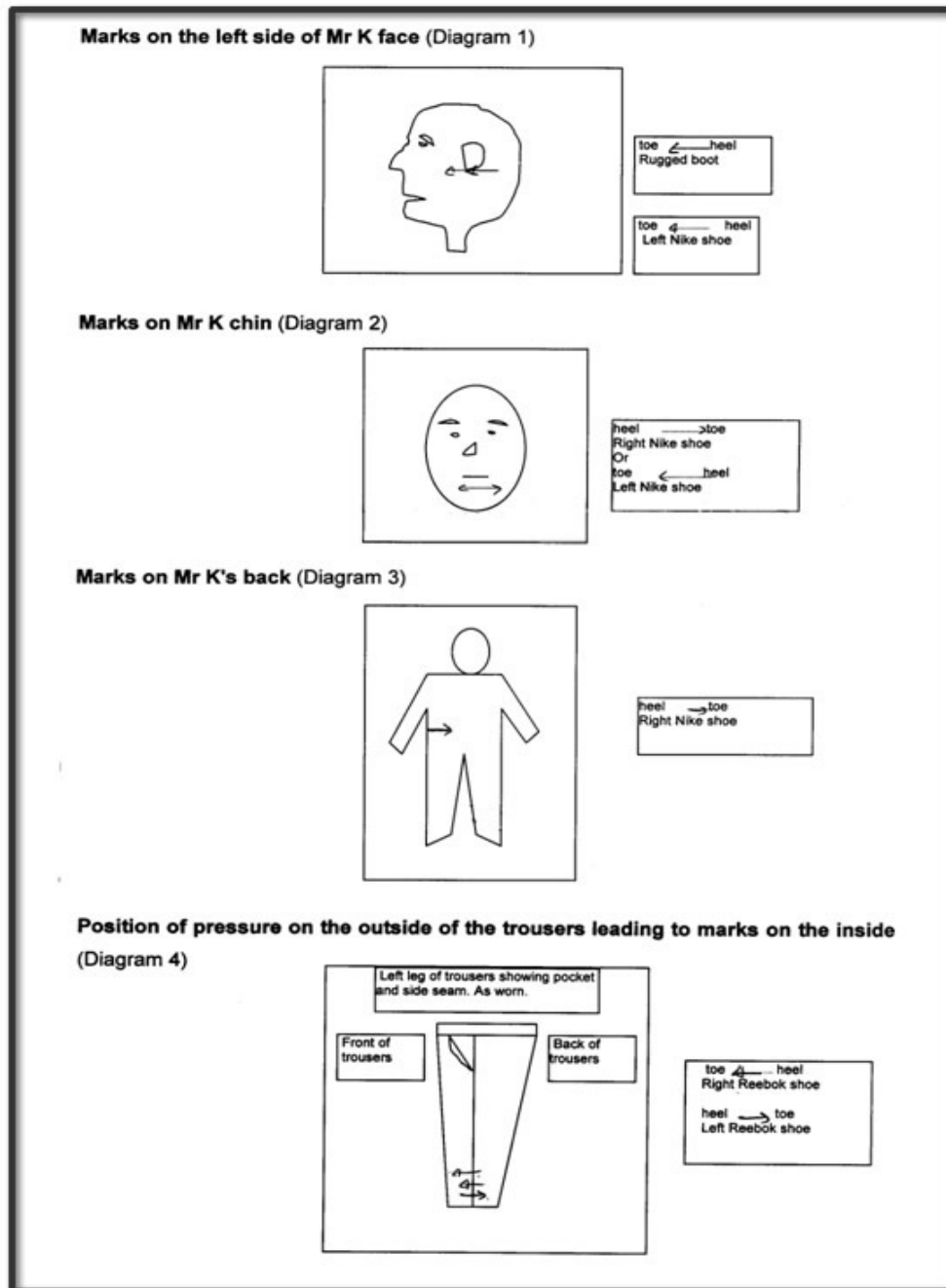
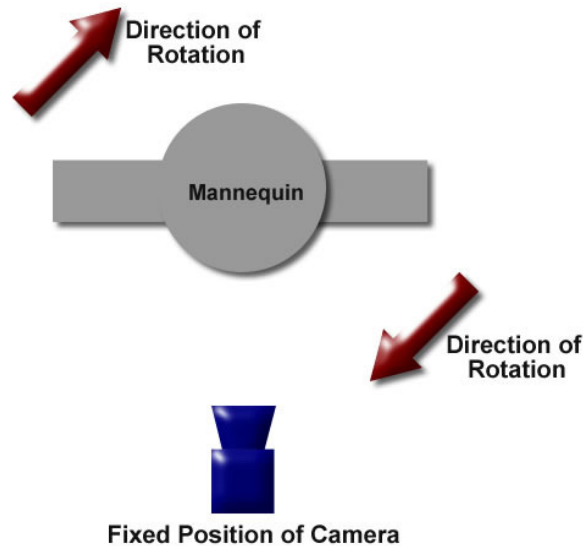

**Figure 4.6** – Original Presentation Illustrating Shoeprint Evidence.

Discussion regarding the best possible way to convey this information led to a decision to utilize web-based technology. Since bruising was found on the front and back of the victim's body, use of a 3D representation of the body was suitable. QTVR object movie provides such a technology; which is based around the QTVR architecture seen in chapter 3. However, unlike panoramas, no stitching is required. Instead, the illusion of motion is created by the object movie jumping from one discrete image to the next.

### 4.3.3 Presentation

In order to create a 3D representation of the victim's body that allowed the illusion of rotation, a series of images was needed. Using a mannequin to represent the victim's body, it was rotated while an image was captured every thirty degrees as illustrated in Figure 4.7.



**Figure 4.7** – Capture Process to Create QTVR Movie.

Both the left and right shoeprints from each of the three suspects were scanned and distinctively colour coded. This provided a quick visualisation as to the type of shoe and whether it was the left or right shoe that caused the bruising. By superimposing the scanned shoeprint onto the images of the mannequin, it illustrates the correct orientation and positioning of each shoeprint on the body, allowing the jury to relate the position of the bruising with the shoeprint responsible.

Further detailed scrutiny is made possible by division of the body images into three enlarged sections: head, abdomen and legs. Placement of hotspots over the relevant portion of the body images can be activated to display these enlarged images. This allows the expert witness to concentrate the juror's attention on a single section. In addition, scanned images of the shoeprints can be displayed and rotated separately to aid in the understanding of the injuries. Figure 4.8 shows screenshots of key areas of the presentation.

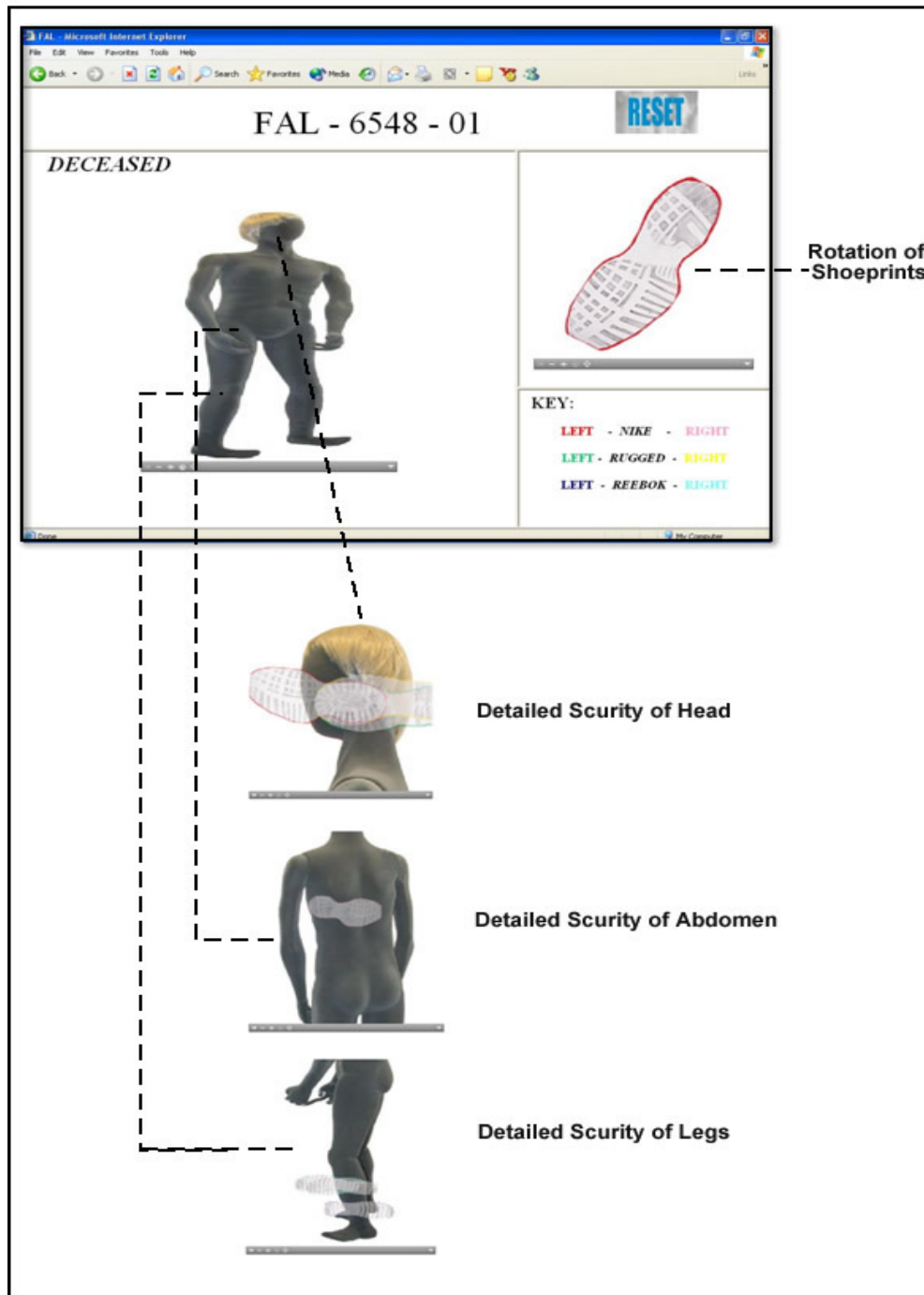

Figure 4.8 – Key Areas of the Presentation.

#### 4.3.4 The Trial

There were some concerns regarding the use of the presentation in court but following numerous discussions with council prior to the hearing, it was generally accepted. The trial was held at the Central Criminal Court also known as the Old Bailey. Although this is a very high profile court, there was no equipment available to accommodate the

use of CG presentation. Equipment such as projector screen, projector and laptop had to be brought to the court and setup by the expert witness. This included balancing the laptop on the witness box while sharing space with case notes proving a difficult task.

A 'jury pack' illustrated in Figure 4.9 was submitted with carefully selected images from the CG presentation. This allows the jury to have a hard copy of the key areas that was presented to them during the trial; this aids their understanding and recollection of the evidence.

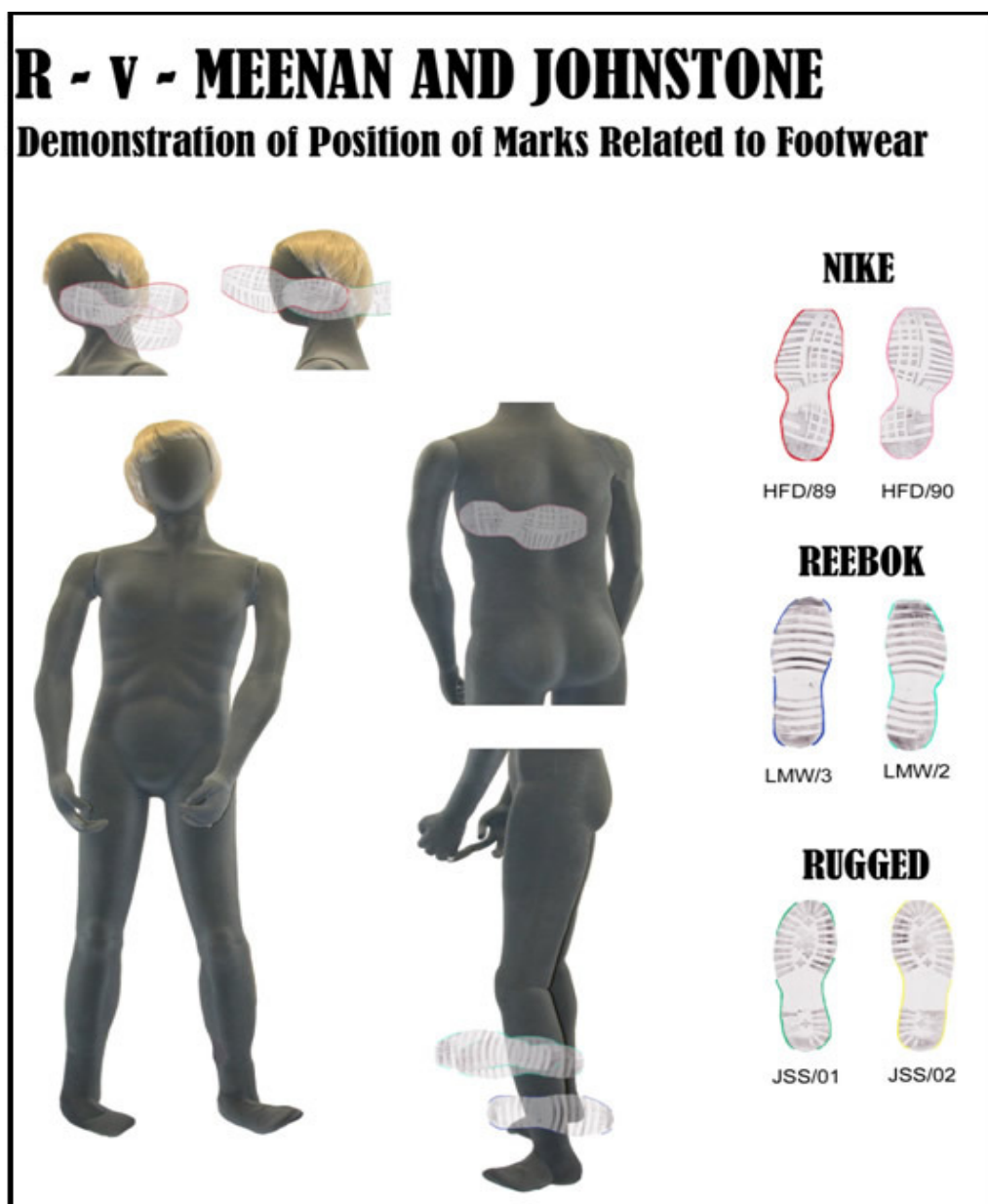

**Figure 4.9** – Compiled Images of the CG Presentation as Part of the Jury Pack.

At the time of trial one of the accused brothers had died. The footwear marks showed a relatively clear pattern around the head, shoulders and the legs. These patterns could be attributed to the shoes from the two brothers. There was a unclear and very partial mark near the ear which could be aligned with part of the boot pattern of the third suspect but it was extremely indistinct and could provide no more than limited support for an assertion that the mark was made by his shoes. The evidence pointed towards the two brothers, which were believed to be the main perpetrators of the attack. Subsequently they were found guilty of murder.

#### **4.3.5 Conclusion**

There were a number of issues that arose during the construction of this CG presentation that may aid any future constructions. By tackling these issues, it helps to prevent any possible dispute regarding its use within court. A particular concern in this presentation was regarding the orientation in which the image of the mannequin body was displayed. Since it is not possible to know for certain the orientation of the victim during the attack, illustrating the victim's body in anything but a floating neutral stand up position would introduce bias and open up the evidence to speculation.

#### **4.4 Case Study 3**

This case was headed by Jennie Lewis from FA, and deals with blood spatter evidence. Analysis of blood spatter can reveal the area of the crime scene and aid in determining the sequence of events that may have transpired.

##### **4.4.1 The Case**

The body of a woman was found dead in her car. Subsequent investigation into her household uncovered the suspect to the husband of the deceased. Detailed examination of the house revealed areas of bloodstains where attempts had been made to conceal the bloodstain evidence.

##### **4.4.2 Requirements of the Case**

The difficulty faced in conveying the blood spatter evidence in court is due to the number of items in the scene that were rotated and repositioned by the suspect; in an



attempt to conceal the evidence. It is the aim of the presentation to illustrate the conditions of the scenes before and after examination by the SOCOs and demonstrate how these changes occurred.

It is difficult to convey this evidence in a way that was easy to understand without the use of CG displays. This is evident from the expert witness's attempt to produce an effective illustration of the crime scene using 2D paper cut-out model. Layers of paper representing the layers of furniture in the scene could be removed, rotated or flipped to demonstrate the concealment of the evidence. Although this approach allows the expert witness a great degree of interaction, it is quite cumbersome due the masses of loose paper presence.

In order to gain a full understanding of the extent of the concealment, the conditions of the crime scene before and after examination by investigators needed to be viewed side by side. A more detailed illustration of key areas of the scene is warranted to allow the viewer to comprehend not only the before and after situation but how the changes occurred.

#### **4.4.3 Presentation**

Web-based presentation was again used as a method of displaying the presentation. In order to provide the interactivity that is required to fully illustrate the extent of the concealment, QTVR object movies and Flash technology was also implemented. This provides a time base presentation rather than just static images. The ability of web-based presentation can be extended to accommodate this through installation of plug-in software.



The CG presentation was divided into three main sections which can be viewed side by side for comparison as illustrated in Figure 4.10. The first section illustrates the crime scene on arrival where the bloodstain evidence had been concealed. The second section shows the scene following post examination and illustrates the scene prior to any attempts of concealment. Through placement of hot spots within the images of section one and two, layers in the scene can be removed to uncover the underlying blood

evidence as presented in Figure 4.11. Dimensions of the room and its key furniture are also indicated on the images to give a scene of scale.

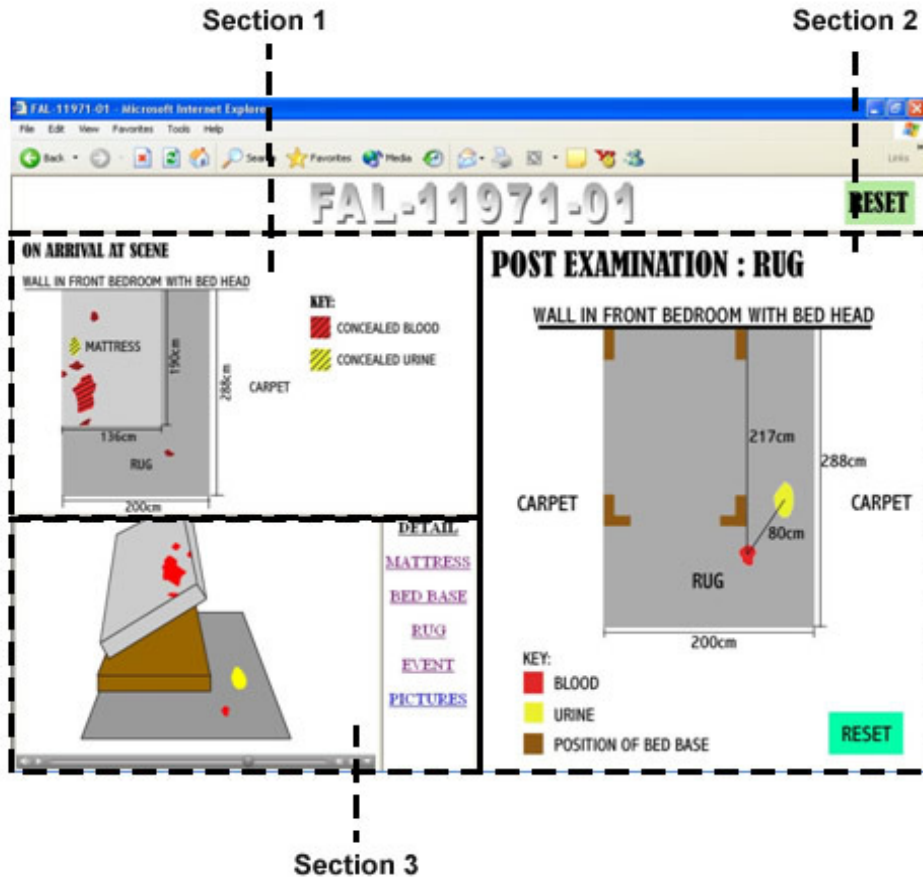

Figure 4.10 – Screenshot Showing the Three Sections of the CG Presentation.

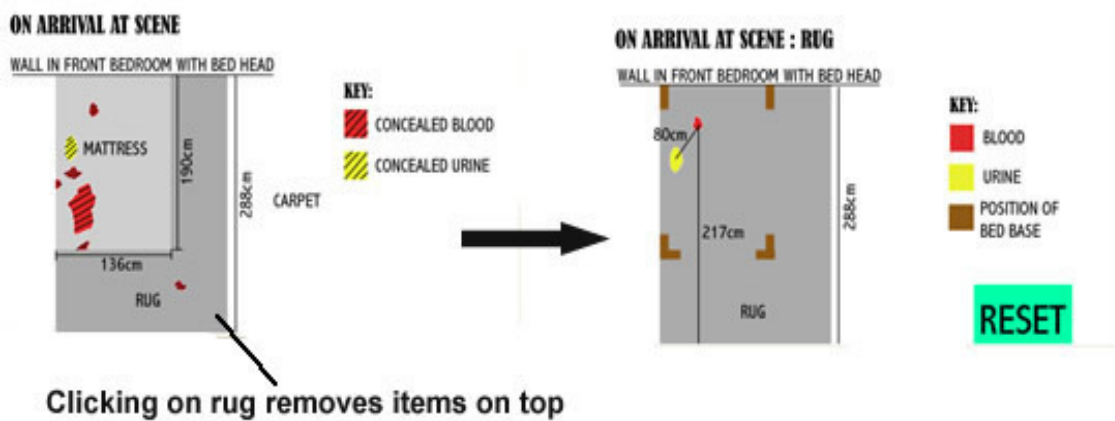

Figure 4.11 – Activation of Hotspots to Remove Layers in the Scene Revealing Underlying Evidence.

The third section of the presentation provides a series of details in support of section one and two. Using QTVR object movie, a demonstration of how the mattress was flipped over to conceal the bloodstain can be shown. In addition, rotation of the rug can be shown in a similar fashion. Flash movie technology provides an additional tool in which the jury can view the events of the crime scene. The Flash movie provides an overview of the evidence and presents it in a linear movie by illustrating the sequence of events that may have transpired in the concealment process of the bloodstains.

#### **4.4.4 The Trial**

Due to the overwhelming evidence against the suspect, a plead of guilty was made and the CG presentation was not required.

#### **4.4.5 Conclusion**

Although the CG presentation was never used in court, several lessons can be learnt from its construction. Displaying three sections on a single page can often overwhelm the viewer with information and produce a sense of confusion. Presenting one section on a page at a time will help concentrate the viewer towards the piece of evidence that the expert witness is trying to convey over at the time.

The setup of each computer can vary considerably from the software browser to the resolution of the screen. Maintaining the look and feel regardless of the client system or browser used are challenges often faced when designing a webpage. Viewing the CG presentation on computers with different resolutions may result in sections not being displayed on screen and require scrolling to bring the section into view. In addition, different browsers often interpret the data slightly different and therefore can display the format of the CG presentation in a slightly altered state such as the font, colour or positioning within the webpage.

Another problem encountered from testing of the presentation within FA was the lack of plug-in software in a large number of the computers. With absents of the correct plug-in, QTVR movie or Flash movie may not be displayed.

#### **4.5 Case Study 4**

This 1:1 taping case is headed by Tiernan Coyle. In collaboration with TVP, this case aims to replicate the success shown in case study 1 and build on the popularity of the 1:1 taping technique.

##### **4.5.1 The Case**

Following a tip off from what turned out to be the son of the suspect, the police attended a scene to discover the body of a woman lying in the lounge, draped over the couch with two stab wounds to the throat. Employing the 1:1 taping technique was considered to be the best approach in preserving and collecting the evidence in the scene. In order to ensure completeness, both the front and back of the victim was taped. Areas of heavy bloodstains were avoided such as the head, throat and upper back and right buttock. A total of one hundred and nine tapings were taken from the body of the deceased; supported by extensive photographs that recorded the position of each taping on the body.

Information received by the police led to the arrest of a suspect. Confirming his presents at the scene, the suspect claims that a fight took place between the victim and two others but he had no involvement and made no contact with the deceased. The suspect's top, shirt and trousers were seized and submitted to the laboratory for fibre analysis. This would help reveal the true extent of contact between the suspect and deceased.

##### **4.5.2 Requirements of the Case**

The requirement of this case is very much similar to those of case study 1. The aim is to present the density of fibres found on each taping and relate it to the position it was found on the body. Since the front and back of the victim was taped, illustration of the taping is slightly more complex than case study 1. Analysis revealed close contact between trousers and lower body, particularly between legs, correlation with fresh bruising noted on post mortem. As discussed in subsection (4.2.2), presenting 1:1 taping evidence in the form of tables is difficult to understand and a CG presentation would greatly aid in conveying this evidence to the jury.

Due to the nature of web-based technology, it is difficult to maintain the exact visual appearance that is intended, as discussed in subsection (4.4.5). Therefore, a decision was made to utilise alternative method of presentation in order to avoid these drawbacks. Standalone Flash technology presents an ideal alternative whereby the presentation can be accurately displayed despite any change in screen resolution. In addition, one section of the presentation should be viewed at a time and information kept to a minimal so as not to confuse and overwhelm the viewer.

### 4.5.3 Presentation

The presentation was divided into five sections; providing sufficient details and focus to be presented. The first section presents an overall transfer of fibres from the accused to the deceased. This helps establish the extent of contact and aid in disproving the statement that the accused had no contact with the deceased. A model diagram of the accused and deceased were used, with the clothing represented by colour and patterns obtained from scene photographs. Since the evidence in this section was related to the overall transfer and not the exact position on the body, there was no need to utilise scene photographs; keeping the evidence objective (Figure 4.12).

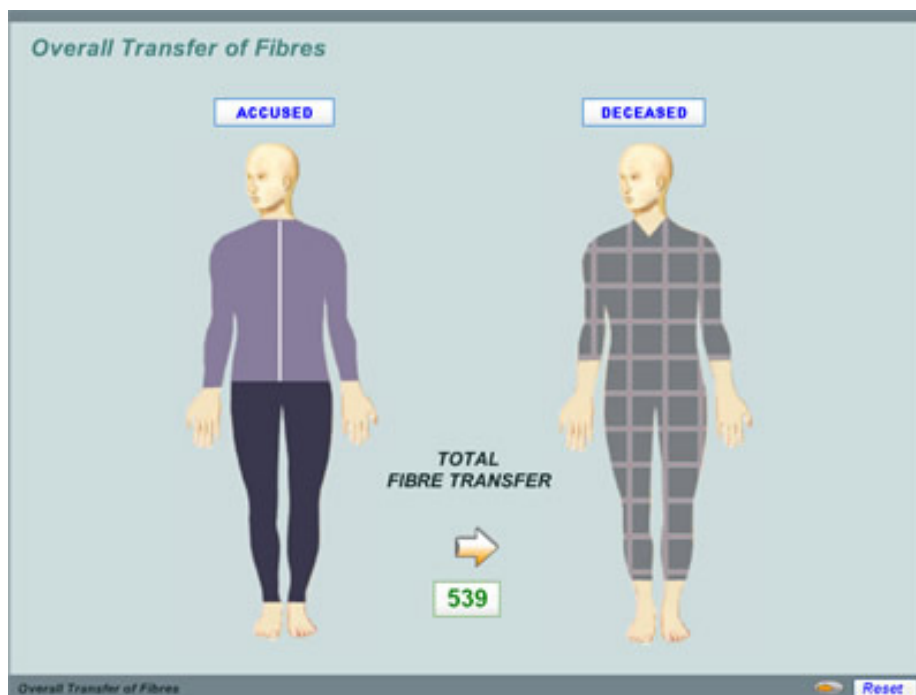
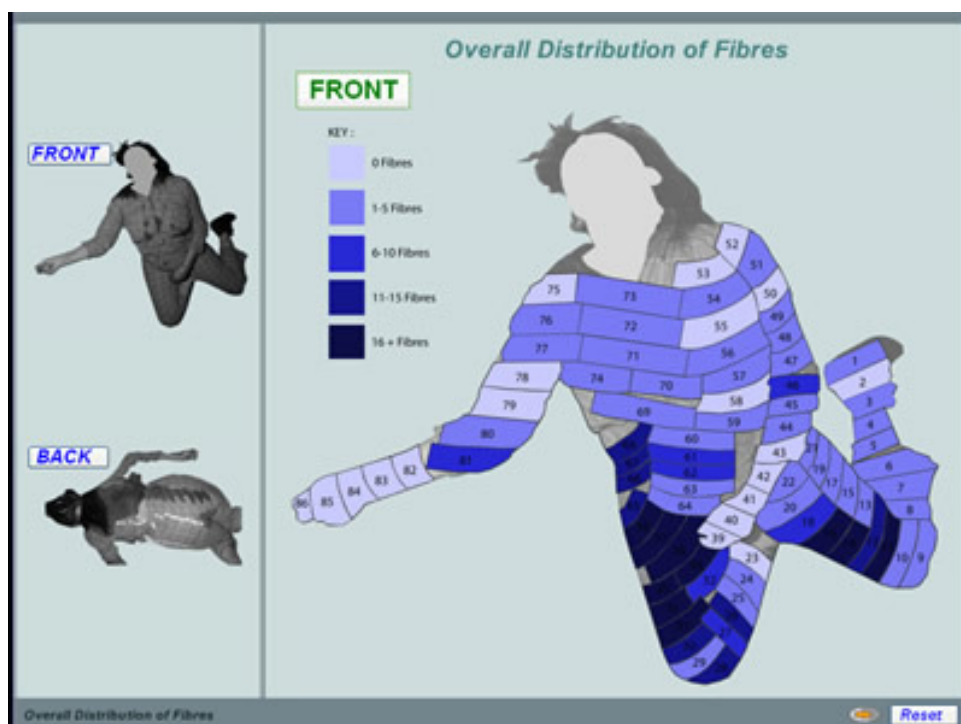

Figure 4.12 – Overall Transfer of Fibres

However, in section two and three, the evidence presented is concerned with the distribution of fibres on the surface of the deceased body. Therefore, scene photographs have been implemented to accurately represent the body; showing the position of the tapings for both the front and back of the deceased. In order to avoid a shock factor, the face of the deceased on the photographs was blocked out and the photograph faded. This was to allow the evidence to be related to the position on the surface of the body without drawing the focus on the image of the deceased itself. In addition, colour can often add confusion to an image, therefore the colour from the photographs was removed. Section two of the presentation deals with the overall distribution of fibres on the body of the deceased as illustrated in Figure 4.13. The frequency of the fibres were grouped into 5 categories and colour coded with darker colours representing increase frequency of fibres. The areas of taping on the photograph of the body were then coloured accordingly.



**Figure 4.13** – Overall Distribution of Fibres.

Section three provides a detailed account of each fibre distribution on the surface of the deceased. In addition to an overview photograph of the deceased, a selection of scene photographs were chosen to represent a more close up view of each section of the body.

With a blue spot representing a single fibre, each fibre found on the body of the deceased that was a match to the suspect's clothing were represented on the scene photographs as shown in Figure 4.14.

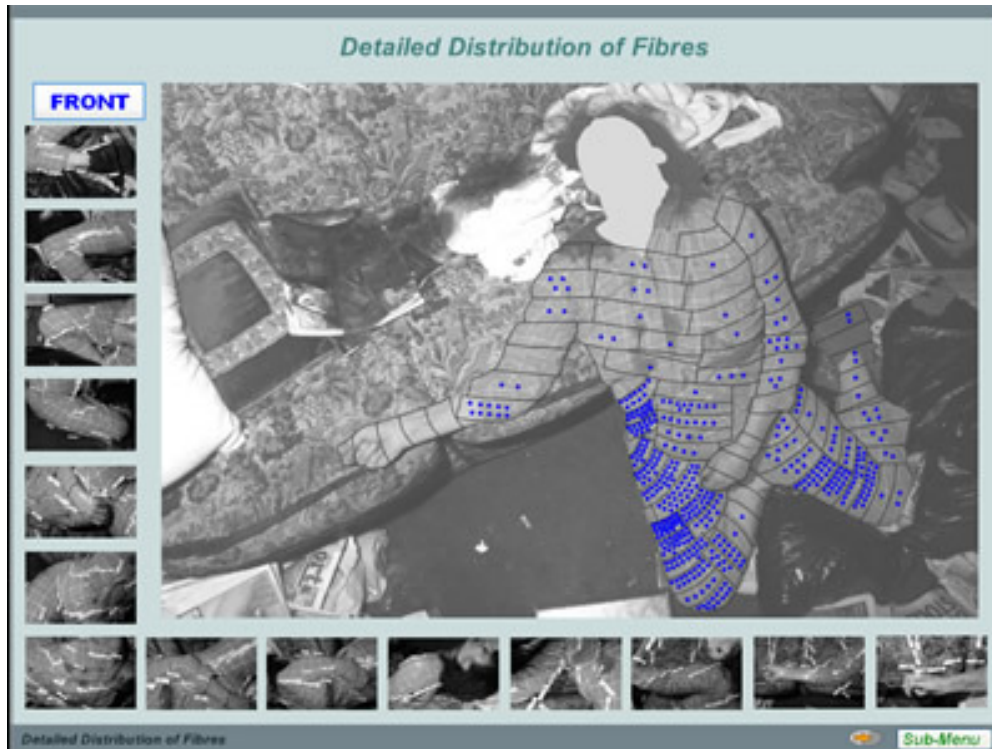

**Figure 4.14** – Detailed Distribution of Fibres.

Section four shows scanned images of the tapings taken from the body. An image of the deceased is shown with areas of tapings numbered to show its position. As shown in Figure 4.15, clicking on the numbers in the centre console displays its corresponding image of the tapings for viewing.

Figure 4.16 shows section five which displays a range of scene photographs that may be useful to the expert witness during the trial. Each photograph has been converted to grey scale to allow the details of the scene to be seen more accurate without the confusion that colour can bring. The photographs taken by the SOCOs were numbered during the investigation and these were carried over to the presentation. By clicking on the number, the corresponding scene photograph was displayed.



The presentation was structured so that five sections were control from a central console. A reset button placed in each section reverted the user back to this central page and allowed the presentation to proceed in any order.

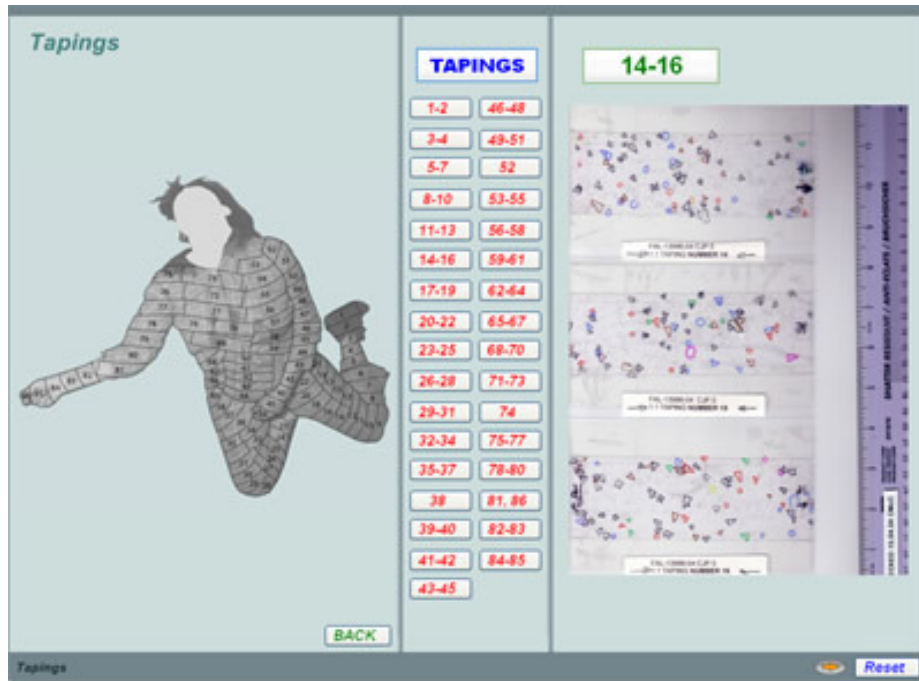

**Figure 4.15** – Scanned Images of Tapings Taken from the Deceased.



**Figure 4.16** – Display of Scene Photographs.



#### **4.5.4 The Trial**

Reading Crown Court where the trial was held possessed limited equipment to deal with the demands of a CG presentation. Although plasma screens were available which could be linked to laptops, the resolution was poor.

The jury pack submitted was similar to that used in Case Study 1, which consisted of a collection of photographs supported by the CG presentation. With the substantial evidence against the accused, a verdict of guilty was given and sentence of life imprisonment was passed.

#### **4.5.5 Conclusion**

Publishing the presentation in an executable format produced a self contained presentation that requires no plug in and therefore run on all PC systems. Additionally, the scalable nature of the presentation means that the visual presentation is not affected by the resolution that the presenting computer has been set to. Therefore, using the presentational technology enables the presentation to be view as intended independent of which computer is used.

#### **4.6 Historical Development**

Construction of the four case studies have help demonstrate the effectiveness that CG presentation can have in the courtroom and the potential benefits that it can bring to forensic science. Implementation of the four CG presentation within FA has not only demonstrated its benefits and ease of use to the forensic scientist involved in the cases, but by word of mouth and demonstrations has allowed other scientist to become aware of these alternative techniques available. With each case study carried out, lessons have been learnt which have aided in the development of later case studies. These have helped establish a good foundation and guidelines in which to produce effective forensic CG presentations. These include:

- **Engagement of the Viewer** – The presentation should engage and retain the attention of the viewer otherwise vital evidence may be overlooked. The opportunity must not be lost in communicating the case.

- **Minimal Information** – Care must be taken not to overwhelm the viewer with information on the screen. Only the evidence that is being communicated by the expert witness at the time should be displayed on screen. This will focus the viewer on the relevant evidence rather than allowing them to gaze at unrelated information.
- **Structure** – Time should be taken to develop a well structured CG presentation. This will allow information to be recalled easily in any order by the expert witness.
- **Minimise Shock Factor** – Cases where the crime has resulted in death often involves showing photographs of the deceased that may not be received kindly by the jury or the family of the victim. Therefore, unless particular references to the photographs are required, images used in a presentation should be replaced with representation. In cases where scene photographs are required, images should be desensitised to avoid unnecessary shock factor.
- **Compatibility** – The way a computer is setup such as the screen resolution and software installed can directly affect the way that the CG presentation is displayed. Every possible care should be taken to maintain the appearance of the presentation regardless of the computer used.
- **Clarity** – Crime scenes that have many colourful items within the scene can overwhelm a photograph and distract the viewer from the relevant information. By converting a photograph to grey scale, this can help eliminate this problem and assist in focusing the viewer's attention.

#### 4.7 Summary

This chapter has followed the construction of four CG presentations from four case studies. In collaboration with FA it has provided an insight to the challenges faced in constructing a CG presentation for use in the courtroom. Lessons learnt during their construction has aided in establishing guidelines. These can be applied to any future constructions and aid in producing an effect CG presentation as well as preventing possible challenges by opposing council.

## Chapter 5: PROTOTYPE

### 5.1 Introduction

This chapter presents the three stages of development of the prototype imaging system: Camera, Stage and Software. The requirements of the system will first be discussed to ensure that the necessary components are incorporated into the prototype imaging system. Each stage of the system's architecture will be carefully examined, taking into consideration their roles within the system, the parameters and limitations of each component that can directly affect the system's performance.

### 5.2 System Architecture

The prototype imaging system will provide a semi-automated system capable of capturing images necessary for the construction of a panorama. The three main components that make up the system's architecture are the camera, stage and software. Figure 5.1 represents how each component is interconnected, each forming an integral part of the overall imaging system.

The sole purpose of the camera is to acquire the necessary images necessary to construct a panorama. The stage provides a platform that houses all components of the imaging system including the camera and stepper motors. The purpose of the software is two folds; to provide access to the camera's functions and control the positioning of the stepper motors and thus the camera.

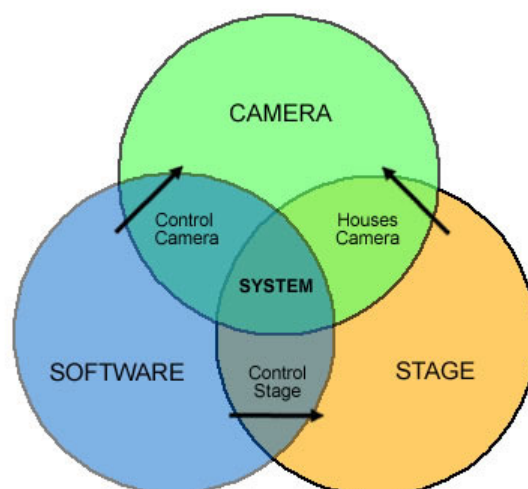

**Figure 5.1** – Three Components of the Imaging System.

### 5.3 Requirements of the System

Adhering to guidelines during the design and construction of the prototype imaging system will ensure that the fundamental features are incorporated, and aid in providing a practical and realistic tool for forensic use. In subsection (2.4.1), basic requirements of the imaging system were formulated following meetings with staff from FA. This section aims to expand on these requirements, providing a framework for the subsequent design and construction of the imaging system. These are listed below and illustrated in Figure 5.2:

- **Camera**
  - **Low Cost** – With the high number of digital cameras available on the market, a careful balance between cost and quality must be attained; ensuring that the overall cost of the imaging system remains low.
  - **Quality** – The resolution of the camera will govern the quality of the output images and thus the panorama. For the purpose of forensic use, the camera should be sufficient quality to accurately depict the scene and its contents.
  - **Accessibility** – The ability to control the camera via a computer is vital in providing a semi-automated system. This allows the computer to initiate the capture process without physical human interaction with the camera. The use of removal memory places limitation on the number of images that can be stored. The ability to transfer images directly to the hard drive of a computer removes this limitation, and with the substantial size of today's hard drives, file size becomes insignificant.
  - **RAW Format** – The camera should possess the ability to capture in RAW format. This is an important feature that aids in preserving the integrity of any images captured by preservation of details within an image. RAW format is essentially an image direct from the image sensor and therefore has not undergone any post capture processing that may result in lost of data.
  - **Manual Control** – The lighting conditions of each crime scene varies considerably. The camera should possess the ability to provide manual

control over the shooting setting thus allowing for consistent exposure to be attained. This ensures a smooth transition between images and aid in the stitching process.

- **Stage**

- **Durability** – The construction of the stage should be of sufficient robustness to support all components of the system and endure the routine transportation of the equipment to and from scenes.
- **Portability** – Ensuring that the system is light weight will provide easier transit to and from scenes and aid in persuading users to employ at a crime scene.
- **Minimise Contamination** – Issues of contamination is a major concern especially when dealing with crime scenes which can have drastic effect on the outcome of an investigation. Therefore minimising the risk of contamination is priority in the construction of the imaging system. Suspension of all loose components on the stage will ensure minimal contact with the scene.

- **Software**

- **Ease of Use** – The software must be simple to operate and self explanatory to ensure that users of any technological ability can utilize with little difficulty.
- **Time** – Time available to capture a crime scene in its untouched state is relatively short. The system should complete its cycle of capture in a relatively short period of time without compromising on the quality of any images acquired.
- **Format Conversion** – The software should be able to convert any RAW images captured by the camera to a more useable format which can then be applied to the stitching software.
- **Modes** – Different modes should be available in the software to allow user of different experience a varying degree of control.
- **Progress Report** – While the imaging system is in the process of capture, indication to the number of images captured and its transfer should be displayed to allow its progress to be charted.

- **Tutorial** – A tutorial should be accessible to provide any additional information that a user may require concerning the theory and operation of the imaging system.

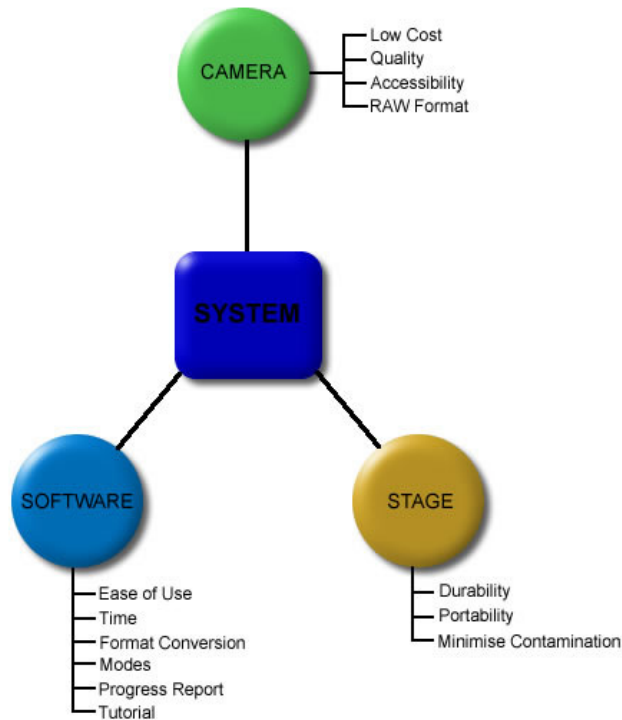

**Figure 5.2** – Requirements of the Imaging System.

## 5.4 Hardware

The hardware of the imaging system comprises of the camera and stage. These will be examined in turn, giving careful consideration to the parameters of each components utilised. Identification of the limitations will not only allow the capabilities of the imaging system to be realised but also enable solutions to be proposed to overcome them.

### 5.4.1 Camera

The primarily role of the camera within the imaging system is to capture the required images necessary to create a panorama of the scene. A decision to utilise still digital cameras rather than surveillance CCD cameras or video cameras is due to their lower costs and generally greater resolution that digital cameras exhibit as discussed in subsections (3.4.3.3).

Careful consideration was given regarding the type of digital camera to implement into the imaging system. The requirements stated in section (5.3) for a digital camera enable a number of cameras to be excluded from consideration. Following a comprehensive search of the market at the time, the Canon PowerShot G3 was revealed to be the ideal candidate for use in the proposed imaging system (See Appendix C).

The Canon PowerShot G3 digital camera offers high quality at a low price. Its ability to be controlled directly by a computer through a USB interface makes this ideal for semi-automating the capture process. Through the supplied open-source Visual Basic (VB) software, the functions of the camera can be integrated into the system's software. Images recorded by the camera can also be directly transferred to the computer's hard drive, removing the necessity for a high capacity memory card and minimising human interaction.

Determining the limitation of the camera is vital to ensure that the constructed system is adequate to serve its purpose. While the majority of the camera's specifications can be attained from the manufacturer, several features of the camera require further calculations or experimental work to determine.

#### 5.4.1.1 Field of View

The FOV of a camera's lens as illustrated in Figure 5.4 indicate how many degree of a scene is captured within a single image.

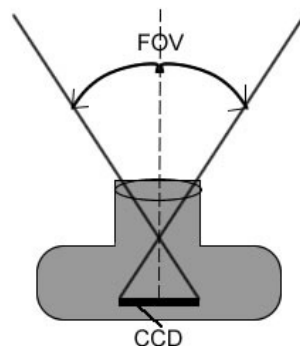

**Figure 5.3** – FOV of Camera's Lens.

As discussed in subsection (3.4.3.1), a certain amount of image overlap is required in order to ensure that a panorama can be stitched together easily; a value of 30-50 percent is usually cited. The FOV of the camera's lens will determine the number of images required to achieve the desired percentage overlap.

The HFOV refers to the horizontal stretching of an image while the VFOV refers to its vertical counterpart. Mounting a camera in a portrait orientation as illustrated in Figure 5.5 will essentially increase the vertical pivoting range for a single-row panorama. This also has an affect in decreasing the number of rows required in capturing a multi-row panorama. Any further reference within the thesis concerning the camera's orientation will refer to that shown in Figure 5.5.

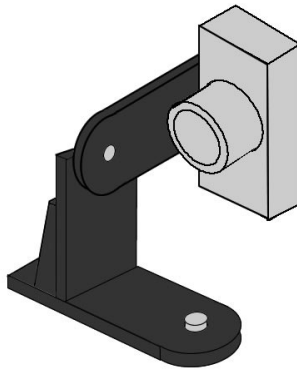

**Figure 5.4** – Orientation of Camera.

The FOV of a camera's lens is determined by its focal length and the size of the camera's image sensor. Based on the diagram shown in Figure 5.6, the FOV can be calculated as below:

$$\tan \theta = \frac{H/2}{R} = \frac{h/2}{f} \therefore \theta = \tan^{-1} \left( \frac{h/2}{f} \right)$$

$$\text{FOV} = 2\theta$$

$$\text{FOV} = 2 \tan^{-1} \left( \frac{h/2}{f} \right)$$



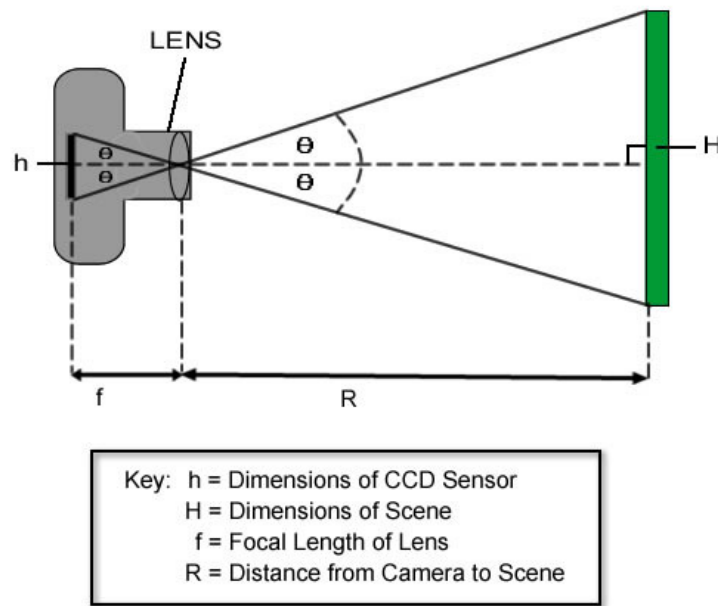

**Figure 5.5** – Relationship of FOV and Camera’s Dimensions.

The CCD format indicates the dimension of the CCD sensors. The specification list in subsection (5.4.1) shows this to be 1/1.8 for the Canon PowerShot G3. From Table 3.1 in subsection (3.3.1.3), the dimensions of the CCD sensor is:

Horizontal dimension of CCD – 5.319 mm

Vertical dimension of CCD – 7.176 mm

Table 5.1 shows the calculated value of the VFOV and HFOV for the Canon PowerShot G3 digital camera.

Lens Focal Length (mm)	FIELD OF VIEW	
	Vertical FOV (Deg)	Horizontal FOV (Deg)
7.2	53.0	40.6

**Table 5.1** – FOV of the Canon PowerShot G3.

#### 5.4.1.2 Resolution

It is important for the purpose of forensic work, that the digital camera utilised in the imaging system possesses adequate resolution to accurately represent the scene and its contents. Resolution ultimately comes down to how much detail you can see in an

image [Imaging Resource, Accessed 2006]. The camera's ability to resolve detail is determined by a number of factors, including but not limited to the performance of the camera's lens, the number of addressable photo elements and the electrical circuits in the camera [BSI, 2000]. This subsection aims to determine the performance of the camera's lens and thus the capability of the proposed imaging system.

#### 5.4.1.2.1 Focus

A lens such as the Canon PowerShot G3 that is capable of high resolution performance can be greatly affected by the camera settings. The focus setting of the camera is one such issue that can reduce the effective resolution. The ability to autofocus is essential in order to provide semi-automation to the imaging system. Autofocus is a feature of most digital cameras where it automatically moves the lens in and out until the sharpest possible image of the subject is obtained. In contrast, manual focus which is available on some high-end digital cameras requires that the user manually adjust the focus of the lens to obtain a clear image. Manual focus is impractical for the purpose of the imaging system since the presence of the user is required for the capture of each image. Although autofocus is vital to the imaging system, there are drawbacks associated that can greatly affect the stitching process. There are several methods of autofocus; but generally the digital camera will designate the middle section of an image as illustrated in Figure 5.7 as the centre of focus.

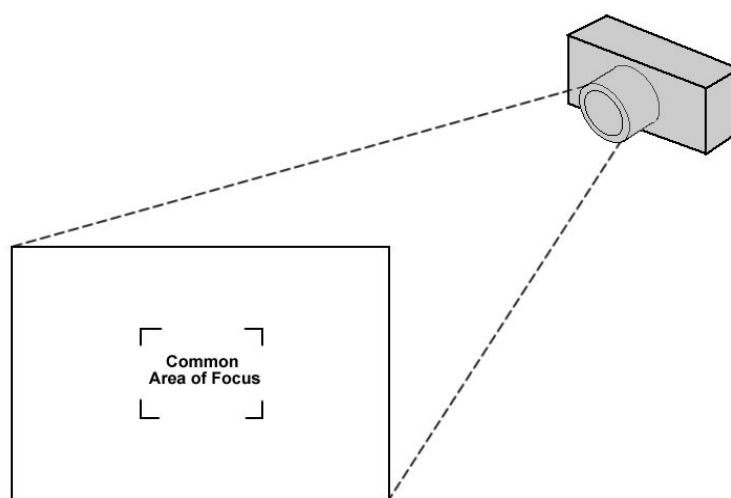

ERROR: stackunderflow  
OFFENDING COMMAND: ~

STACK:

## **Chapter 6: APPLICATION CASE-STUDY**

### **6.1 Introduction**

The procedures involved in assessing the value of the imaging system does not lie in the number of features or types of equipment it possesses, but in its ability to perform in real world situations. The ability to quickly construct an accurate VE corresponding to a real scene can be an extremely powerful tool [Gibson, 2000]. This chapter presents an evaluation and assessment of the imaging system in relation to its value as a forensic tool. The imaging system will first be applied to a crime scene scenario where the performance of the system and its resultant virtual scenes can be examined. The imaging system will then be presented to a representative group of intended users for evaluation. This will provide invaluable data regarding the practicality of the imaging system. Refinement and improvements can then be applied to the imaging with the feedback received.

### **6.2 Trial of Imaging System**

The development of the imaging system resulted in four separate components: the camera, tripod, circuit box and platform. Assembly of these components as well as a laptop are required before the imaging system is ready for deployment. This will yield a semi-automated imaging system capable of acquiring images that are necessary for the construction and rendering of a cylindrical or spherical panorama. Its capacity as a forensic tool lies in its ability to provide a simple to operate system and reproduce an accurate representation of a crime scene. Deployment of the imaging system in a real world crime scene will aid in gauging its level of functionality.

Lancashire Police and Thames Valley Police force showed keen interest for me to attend low profile cases and trial the prototype imaging system with police personnel. However, due to the sensitivity of evidential material, law advisors to the police held reservation on the impact that the presence of the imaging system and non-police personnel may have on the case at hand. This resulted in both police constabularies abandoning the trials. The construction of a simulated crime scene that replicated the real world as closely as possible provided an alternative method for the trial of the

imaging system. Although a simulated crime scene cannot match the level of details present in a real world crime scene, it will nevertheless demonstrate the potential and ability of the prototype imaging system.

The aim of the trial is two-folds; to establish the functionality of the imaging system and also demonstrate the potential of a constructed virtual scene. The simulated crime scene utilises a secluded lodge as the location of crime. This allows control over the movement of items within the scene and removes the drawbacks of moving vehicles. As discussed in subsection (3.4.3.1), the movement of objects from one image to another (i.e. moving vehicles) may result in blurring of the resultant panorama. The main crime scene is situated within the lodge where a simulated crime is portrayed in which a victim lies suffocated. Items of evidence placed around the representation of the victim's body aims to illustrate that a perpetrator had gained entry to the lodge and a struggle took place with the victim.



Assessing the function of the overall imaging system involves capturing a series of images necessary for both a cylindrical and spherical panoramas. This allows for a direct comparison between the two types of panoramas in terms of the process involved in capturing the images and their output panoramas. Since a crime scene is not limited to the immediate area in which the victim's body is located, capturing panoramas outside the lodge will provide a sense of surrounding. Evaluating the system in an outdoor location will allow for its ability to function in surroundings that cannot be controlled to be assessed alongside an enclosed and controlled site.

Demonstrating the potential of a constructed virtual scene involves illustrating the flexibility and ability to accurately represent a crime scene. The flexibility of a virtual scene lies in its ability to interlink a number of panoramas through hotspots and thus give the user a sense of movement. In addition, hotspots allow all case related material to be integrated into the virtual scene. This can include images of the items of evidence allowing for a more detailed scrutiny and case notes, thus providing a logical folder for easy viewing.

Due to the lack of available forensic and police personnel for the trial at the time, the assessment of the imaging system is based on my own personal views. Although this may differ from the professional communities, it does help to highlight any potential problems that may be encountered.

The first challenge that the imaging system may be faced with is transportation of the equipment to the crime scene. As a method to prevent contamination of a crime scene, forensic stepping plates are often used which outline a common pathway that all personnel follow. This restriction in movement within a crime scene and the number of separate components and its weight may present a challenging task in the transportation and assembly of the imaging system. Limiting the pathway inside the lodge enables the trial to emulate some of the conditions that may be experienced in a real world situation. Due to the number of components involved, two trips were required to transport all equipment to the site. Once this was achieved, assembly of the imaging system was found to be relatively quick and straightforward. It was found that the tripod and platform should be transported first to ensure that the frame is established at the earliest stage possible enabling the subsequent components to be supported.

Images necessary for the construction of both a cylindrical and spherical panorama were acquired of the simulated indoor and outdoor crime scene. The time taken for the acquisition of images was found to differ depending on the type of panorama and graphic format utilised. In cylindrical mode, the average time taken was five minutes and forty five seconds whereas a spherical panorama took a considerably greater time of twenty nine minutes and thirty seconds. The increase in time for spherical panorama is not only evident in the capture process but also in the construction and display of the panoramas. This is due to the large number of images involved resulting in a large QTVR panoramic file that requires an increase in processing power and memory to render and display the panorama efficiently. The use of RAW format further increases the time of capture due to the large size of the file compared to JPG that must be transferred to the hard drive of the computer.

Following construction of the panoramas and additions of the hotspots to form the virtual scene, it was discovered that QT 6.3 is required to correctly allow activation of the hotspots. Due to an unexplained bug within QT, versions of QT greater than 6.3 resulted in failure of the hotspot. (*QT 6.3 is supplied on the supplementary CD*).

In terms of the constructed panoramas, greater flexibility can be seen in the spherical panoramas. The drawbacks of cylindrical panoramas lies in its limited VFOV as illustrated in Figure 6.1 whereas spherical panoramas offer the user the ability to view a full scene. Therefore, positioning of the imaging system becomes of greater importance for the capture of a cylindrical panorama. Important evidence may not be documented and therefore overlooked as a result of positioning the imaging system in close proximity to a subject. This is evident in the cylindrical panorama captured from the trial which illustrates the failure to capture evidence two and six. In order to overcome this limitation, a cylindrical panorama should be captured from a number of locations within the scene to ensure that any evidence not captured in one panorama is present in another



**Figure 6.1** – Limited VFOV of a Cylindrical Panorama.

Although a spherical panorama offers the advantage of increase VFOV over its cylindrical counterpart, due to its increase number of overlapping images, spherical panoramas are more prone to movement within a scene. This is evident in the spherical panorama of the outside of the lodge as illustrated in Figure 6.2, where movement of the branches resulted in slight blurring of the resultant panorama.



**Figure 6.2** – Blurring of the Resultant Panorama.

### 6.3 Evaluation Approach

The imaging system as a forensic tool can bring many benefits to the procedures involved in documentation of a crime scene. However, real world application of the imaging system is dependent on the willingness of forensic personnel to utilise it at a crime scene. There are many aspects of the system that may encourage and also discourage the use of the imaging system. This subsection aims to attain the views from the intended end users and identify any potential obstacles that may be faced with the application of the imaging system. In order to obtain the necessary information, a representative group of forensic and law enforcement personnel would be used to analyse and evaluate the imaging system. Each personnel in turn are introduced to the imaging system for the first time and should possess no prior knowledge in its operation. This ensures that the level of knowledge is equal and thus the evaluation will provide a good representation of how the system will be received.

As an initial form of data gathering, a questionnaire as illustrated in Figure B.1 is presented to each user; to be completed throughout the evaluation process. The questions aim to gauge the value of a number of features of the system by means of a



likert scale. The evaluation of the imaging system commences with a quick verbal introduction and presentation of the tutorial to the user. This enables users to familiarise themselves with the key concepts and operation of the imaging system before trialling the system. Once this was accomplished, the components of the imaging system in its unassembled state were presented to the users. Invited to handle the equipment to obtain a sense of weight and ease of transportation, the user is then requested to assemble the system to its fully functioning state and initiate capture of a panorama in RAW format. This demonstrates the clarity of the tutorial and its ability to translate instructions to the user in the actual operation of the imaging system. This hands-on approach allows users to gain first hand experience of the system which aids in revealing any difficulties that may be encountered. With the acquired images in RAW format, conversion to a more usable graphic format is necessary for application to the stitching software. Guided by the tutorial, the user is instructed to batch convert the captured images to the JPG format. Once the images are converted, the operation of the imaging system is complete. Construction of a panorama from the acquired images are performed through third party stitching software and therefore not an element of the imaging system. The user are therefore not required to apply the images to a stitching software, but instead is presented with the simulated crime scene constructed in section (6.2). This will illustrate to the users the possibly virtual scenes that can be constructed as a result of utilisation of the imaging system.

Following sufficient time for the users to explore the constructed virtual scenes, each user was subjected to a structured interview. Illustrated in Figure B.2, the structured interview aims to acquire constructive criticism regarding the capability and practicality of the imaging system. Opinions on how the imaging system will perform in real world situations and its possible reception within their departments will also be the focus of the interview. Focus will also be placed on the current status of digital imaging within their individual department and opinions on the current crime scene documentation techniques will be acquired. This allows the true value of the imaging system to be realised, when assessing its performance alongside current crime scene documentation techniques.

#### 6.4 Analysis of Results

The intention to expose a mixed group of at least twenty forensic and law enforcement personnel to the imaging system was faced with setbacks. This was due to an unpredictable emergence of a high profile case which resulted in the majority of the volunteers that were expected to attend the trial to cancel just a few hours prior. As a result, only seven volunteers were available for evaluation of the imaging system and therefore any statistical analysis would not provide any reliable information. Nevertheless, information gathered through the questionnaires and structured interviews provide valuable data that helps to indicate and reflect on possible issues that the utilisation of the imaging system may create. Different areas of expertise and experience of the volunteers can illustrate the diversity of the imaging system and how it may benefit their work. Table 6.1 present the seven volunteers that took part in the evaluation including their area of expertise.

Volunteer	Role	Area of Expertise
1	SOCO	Crime Scene Processing
2	SOCO	Crime Scene Processing
3	Forensic	Photography
4	Forensic	Footwear Marks
5	Forensic	Chemistry
6	Forensic	Biology
7	Forensic	Toxicology

**Table 6.1** – Volunteers of the Evaluation.

The responses from the questionnaire and structured interview allow us to gauge the achievement of the requirements that were outlined in chapter 2. Comparisons of these responses will allow correlation of a number of features of the imaging system to be established and these provide a possible explanation behind the responses.

The function and operation of the imaging system can be divided into two areas: assembly of the hardware and operation of the software. Ease of use of the imaging system is a key requirement that will allow users of any ability to operate with little

difficulty. Responses from the questionnaire and structured interview will allow us to gauge whether these have been achieved and also pose possible explanations for the results.

The assembly of the hardware encompasses all stages, from the transportation of the equipment to the assembly of the imaging system. Question four of the questionnaire aims to evaluate the level of ease at which the volunteers found the assembly of the imaging system. There were no serious difficulties observed by the volunteers during the evaluation however, some of the volunteers found the task to be easier than others. The difference in responses underlines the presence of weaknesses within the prototype imaging system that can be due to a number of factors. Possible explanation can be established by comparison of a number of system's features to the responses received concerning the ease of assembly.

The imaging system comprises of four components that require transportation and assembly before deployment is possible. The manageability of the system in terms of number of components can have a direct bearing on the ease of assembly. The assumption is that the volunteers that found the number of components to be manageable will have also experienced an easier assembly of the system. The responses indicate the volunteers found the number of components to be generally manageable and acceptable which supports the assumption. Volunteers that found the ease of assembly to be average also found the manageability of the components to be average. In contrast, those that experienced an easier setup of the hardware also found the manageability of the component to be greater. It is therefore plausible that reduction in the number of components associated with the imaging system will result in a greater ease of assembly.

The weight of the imaging system is an important factor which may affect not only the ease of assembly, but the sturdiness and desire of the end users to utilise the system. The assumption that a more light weight system would result in an easier assembly of the imaging system is reflected in the responses received. Five of the seven volunteers found the weight of the imaging system to be quite manageable while the remaining two

found it to be average. This shows a positive correlation, as the manageability of the weight of the system increases, the ease of assembly becomes easier.

Through the structured interview, it was established that judgement on the weight of the system was based on reference to current forensic and law enforcement equipment. Volunteer 6 expresses that “it is no bigger or heavier than other equipment that we lug around”. Although, these views are shared by all volunteers, there is still a desire for equipment to be lighter in weight. Volunteer 2 states that “it is the nature of our job that we carry a lot of equipment, however, being a woman it is often difficult to manage the weight associated with these”.

Construction of an ultra light system may be beneficial for the purpose of transportation and the assembly of the imaging system, but it can also be detrimental to other aspects of the system. Use of light weight material often denotes increase in cost and a decrease in the sturdiness of the system. Since sturdiness is an equally important requirement of the system, obtaining a balance between weight and sturdiness is essential. Volunteer 1 says “in practical application of the system, it is going to be knocked over and thrown into vans. The system needs to be robust”. While relating the responses of weight and sturdiness, it is found that volunteers that found the system to be lighter also found it to be more fragile. The majority of the comments received on the sturdiness of the system were with regards to the tripod. The tripod that was utilised in the imaging system was considered to be too fragile and on application of pressure resulted in bending of the tripod legs. In addition, volunteer 3 states that the imaging system is very top heavy which can be prone to windy conditions.

The ability to carry out instructions is only as good as the instructions themselves. Failure to communicate instruction to the users can result in difficulties during the setup of the hardware. Question eight aims to identify any concerns regarding the tutorial and its ability to provide adequate information for the setup and operation of the imaging system. The responses from the questionnaire indicate that the tutorial provided quite adequate and average assistance to the users. The correlation observed from the responses illustrates that those who found the tutorial to be quite adequate also

experienced fewer problems during the assembly of the system while those who found the tutorial less helpful also experienced more difficulties in assembling the system.

Volunteer 2 reveals that “Initially from the tutorial, the setup of the system appears complicated but once you have done it, it is actually quite straightforward and I would find it easy to do second time around”. Improvements to the tutorial may result in users finding the initial assembly of the imaging system to be less problematic. Data gathered from the structured interview indicated that the main weakness associated with the tutorial was its layout. Volunteer 7 pointed out that the number of options available on the main menu in the tutorial can cause confusion. By dividing the tutorial into three main sections: hardware, software and information, it provides a more logical layout and therefore allows the correct information to be located more efficiently. Volunteer 1 noted that the hardware setup in the tutorial consisted of a series of consecutive slides. If a particular area required further attention and needed to be revisited, the user is forced to view the hardware presentation from the beginning and must proceed through the slides before reaching the desired information. Division of the hardware tutorial into several sections will allow users to view the desired pieces of information without the need to view the entire presentation.

In addition to the number of components, weight of the system and the tutorial that has been shown to affect the ease of assembly, the volunteers have expressed areas of the system that require further attention. One particular area involved the connections of the two stepper motors to the circuit box. The cables and connectors from the stepper motors are identical in every aspect and this has led to confusion for some of the users that found difficulties in determining the correct connector and its corresponding socket on the circuit box. Incorrect connection of the stepper motors to the circuit box will result in the system’s software activating the wrong motor, and may ultimately cause damage to the system due to the restriction in rotation of the vertical axis. Although the sockets on the circuit box are labelled to indicate the connections of each of the motors, determining which stepper motor is one and two was found to require constant reference to the tutorial. Volunteer 7 and volunteer 1 suggest colour coding as a method to quickly allow identification of the correct connector with its corresponding socket.

Volunteer 1 says “basically the male and female parts should be colour coordinated so you won’t put the wrong motor into the wrong socket”.

In addition, concerns regarding the length of the cables were expressed. Volunteer 3 says “the length of the cables seem to be extremely long. Cables should be just the right size and length”. This will aid in maintaining an organised system and reduce the movement of cables during the capture process which can cause blurring of the resultant panoramas.

The task of attaching the camera to the panoramic head caused complication and confusion to a number of users. Attachment of the camera as discussed in subsection (5.4.2.2) involves a series of steps that user found cumbersome and difficult to complete. Volunteer 1 said that “I would like to see some sort of clip that you can just clip it on and release rather than have to screw it up. That would be more speedy and easier”. In addition he went on to say that “there is a worry that you may over tighten the screw causing damage to the camera, yet on the other hand, if it is not tighten enough, the camera will flop while the motor is rotating”. Determination of the correct orientation and direction of the camera during its attachment to the panoramic head caused some confusion which resulted in constant reference to the tutorial. Volunteer 1 suggests “there should be an indication on the panoramic head showing the orientation of the camera. That way the user only needs to line up the camera to obtain the correct orientation”.

Once the setup of the hardware is completed, the imaging system is in a state that is ready for deployment in a crime scene. This stage of the imaging system requires the user to operate the system’s software in order to initiate the capture process. The volunteers examined the software and analysed the range of options available to gain a better comprehension of the abilities of the software. Question six of the questionnaire aims to identify the level of difficulty associated with the operation of the system’s software. The responses received from the volunteers’ indicated that the operation of the imaging system is considered quite easy. However, differences in responses suggest space for improvement to the system’s software. There are many factors that may be

advantageous and also detrimental to the experience of the user during the operation of the system's software.

The impact that the layout and sequence of button on the user interface has on the overall operation of the system's software can be demonstrated by comparison of the responses from question six and seven of the questionnaire. The response indicates that users who found the layout and sequence of buttons on the user interface to be quite intuitive also had an easier experience of the overall system's software. All users believe the software interface to be relatively straightforward and was just a matter of familiarising themselves with it. However, the aim of the software interface is to be intuitive despite a user's level of experience with the system. Since four volunteers found the layout of the user interface to be only average, this suggest that there are areas of the layout that exist which can benefit from refinement.

One of the principal requirements of any software interface is simplicity. In order to provide a sense of direction to the users and prevent confusion and incorrect activation of buttons, the construction of the user interface made use of buttons that remained in an inactivate state until the correct steps within a stage were reached. Attempts to increase the intuitiveness of the software and reduce confusion to the user were met with some criticism. Even though the use of inactivate buttons provided direction to the software, it was found that the buttons were still visible despite being greyed out in its inactive state adding to the overwhelming information and buttons on the screen. Volunteer 1 suggests that "rather than just using inactive button which are greyed out, the buttons should be invisible and only appear when needed. That way, the user is not overwhelmed with a large number of buttons". Another method to simplify the user interface was suggested by Volunteer 2 who says "increasing the size of the buttons may allow easier identification of the correct buttons".

As discussed, the tutorial provides information that aims to guide the user through the process of operating the imaging system. Comparison between the operation of the system's software and the tutorial will aid to gauge the effective communicative ability of the tutorial to the user. The responses indicated that as the ability of the tutorial to

provide information increases, the operation of the system's software becomes an easier task. Therefore improvements to the tutorial which have already been discussed will aid in increasing the ease in the operation of the system.

Although the use of computers have infiltrated the daily lives of many people both at home and at work, there still remains groups that possess poor computer skills. This diversity in computer skills is evident from the responses acquired from question ten. Although, four of the volunteer rate their computer skills as quite good, the remaining three volunteers were not as confident in their ability with two considering their skills to be only average and one considered it to be quite bad. There was no direct relationship evident between the operation of the system's software and the computer skills of the user. This suggests that the software is intuitive and requires no vast amount of computer skills to operate, therefore achieving a key requirement of the imaging system. This is evident from the responses, showing the least computer literate user still finding the system's software to be relatively easy to operate.

Documentation of a crime scene is a time sensitive issue. Therefore, in addition to providing an imaging system that is easy to assemble, the time required to prepare the system for deployment must be relatively short. Question five of the questionnaire evaluates the volunteer's opinions on the length of time taken to assemble the imaging system. The responses received indicated that five of the volunteers considered the time to be quite short and one user regarded it to be very quick. Only one of the seven volunteers considered the time for assembly to be average. Many factors may influence the time that is required to assemble the imaging system. A direct correlation can be seen where the volunteers that found the assembly of the system to be easier also considered the time of assembly to be quicker. Due to the correlations established between the number of components, weight and tutorial of the system with the ease of assembly, it is possible to assume that these will also have an affect on the time taken for assembly. Therefore, an increase in the efficiency of assembly of the imaging system will reduce the time requirements for the setup of the system and thus yield a more viable imaging system for utilisation in a crime scene.



With the imaging system assembled and ready for deployment within a crime scene, the user can initiate the capture process. The time required for the imaging system to complete its cycle of capture depends on the type of panorama required and the graphic format utilised. When confronted with the times that are required for the capture process as stated in section (6.2), the volunteers were asked for their views on this length of time in comparison to current documentation techniques. Volunteer 1 expresses that “even though a spherical capture takes roughly thirty minutes, the value of the results justifies the extra time”. The application of the imaging system is viewed by the majority of the volunteer to be valuable, particularly at major scenes. Volunteer 2 says “The time is no issue at all because in a major scene which is where you would use this, you allow yourself however long it takes. Thirty minutes is nothing in the grand scheme of things”. This view is shared by Volunteer 7 that says “even though you have to evacuate the crime scene for at least half an hour which stops other people from processing the room, if it’s a big enough case, half an hour isn’t going to make much difference”.

The success of the imaging system is dependent on its ability to perform and the additional benefits it can bring to their profession. Relating evidence to the position it was found in a scene can often be a difficult task with current documentation techniques. Volunteer 6 says “talking to colleagues, just trying to get an overall picture is difficult. It is difficult to convey the separation of items in photographs and diagram”. The ability of the imaging system to tackle this drawback of current documentation techniques is emphasized by volunteer 1 that states “the imaging system as an overview of how items relate to each other in a scene is an excellent tool compared to photography and video since they only give you whatever is in the frame at one time”.

The ability to enhance the value of a virtual scene by insertion of additional information through hotspot provides a user with more than just a visual representation of the crime scene. Over the course of an investigation, case related material can often build up. A virtual scene provides a method to integrate this information into a logical folder whereby users can access this through hotspot within the panorama. Volunteer 2 says

“this can be a very useful method of keeping track of case information and will save time in preparation for court”.

The imaging system can be a powerful tool that extends far beyond the initial investigation. Its ability to communicate the crime scene is beneficial not only to the forensic and police personnel during the course of an investigation but can also serve a vital role in court as stated by the volunteers. Volunteer 2 explains that “in a major scene, you sometimes take a coach load of jurors to the scene so that they can take a look. Potentially, the virtual scene provides a tool where this is no longer needed. It will certainly help the lay person since photographs and videos alone do not give a true picture of space”. Volunteer 1 says “people tend to have different version of what they perceive the scene to be like from the same description. Presenting a scene through panoramas allows people to obtain similar views of the scene”. Although volunteer 7 recognises the benefits that such a tool can bring in court, he points out area of concern that arises from its use. He says “the system provides the jury with accessibility to the information afterwards, they can physically walkthrough and they can follow through everything that’s going on. The problem that you might encounter is that if you created a panorama with hotspots and specific piece of evidence has been removed or tainted or deemed inadmissible, then your presentation is ruined”. Volunteer 3 comments on the practicality of using such a presentation in court. He says “that the use of this sort of presentation is limited by the low-tech equipment that UK courts currently have”.

Differences in complexity in crime scenes present challenges for SOCOs to document all relevant evidence. The imaging system may provide a beneficial tool that aids in this task. However, due to certain properties of the imaging system, there are some crime scenes that its application is not appropriate. Volunteer 1 says “wet scenes may present a problem such as following a fire where there is a lot of water or a body floating in the sea. The system may not hold up to being wet”. Volunteer 7 says “it would be a hazard to use the system in scenes that contain flammable solvents because of the electrics”. The seriousness of the offence would determine the application of the imaging system. Volunteer 2 says “I can’t really see you would use it for petty crime”

while volunteer 1 states that “offences such as burglary wouldn’t validate getting that out and doing a panorama since you are not going to gain anything from it”.

Maintaining the integrity of any evidence recorded is vital in ensuring its admissibility in court. Regardless of the benefit that the imaging system can have in the courtroom, issues of contamination can render the evidence worthless. During the structured interview, volunteers were asked to analyse the imaging system and comment on any contamination issues that they could perceive. Volunteer 1 says “tripods are routinely used in crime scenes with a video camera. Only three parts touches the floor so in terms of disturbing the evidence it is minimal. They put carrier bags over the tripod legs to further reduce the chances of contamination”. As a method of preventing cross contamination, volunteer 4 says “we spray everything with a bleach solution. However, I am not sure whether this imaging system will withstand such cleaning”. Volunteer 3 notes that “the cable texture may not be the best to clean since dirt and dust can be trapped easily. You want surfaces that are easy to clean down”.

The cost of the imaging system will have a direct bearing on the success and willingness of the forensic and law enforcement communities to utilise. Volunteer 2 says “police forces are run like businesses these days and they do have budget constraints. Obviously the cheaper they are the easier it is to get them in”. Volunteer 1 adds “depending on the cost of the unit, it is realistic that every major incident van has an imaging system”.

With the increase in digital photography in the consumer market, how has this translated to the law enforcement communities? There is no doubt in the minds of the volunteers that digital photography will play a greater in their work. This transformation has already been set in motion with the number of digital cameras increasing over recent years in most organisations. Some organisation such as Dorset Police has essentially replaced all traditional wet photography and operates solely with digital cameras. Volunteer 4 says “Its taking over, we going all digital”.

The benefits that digital photography provides over traditional photography have been the basis for the transition to digital within the forensic and law enforcement

communities. Volunteer 6 says “It’s basically a lot more convenient and a lot more flexible”. Perhaps one of the greatest advantages of digital photography is its ability to provide an instant review of the photographs taken. This is particularly valuable for purpose of crime scene documentation as pointed out by volunteer 1 who says “with the wet photography, you wouldn’t be able to see the image there and then. You wouldn’t know whether the captured image is ruined due to the reflective tint or flash back”.

One particular drawback associated with digital photography in forensic work is emphasised by volunteer 1. He reveals that the only problem encountered with digital photography is with regards to footwear marks because there is not enough fine detail. “We would still use wet film for footwear marks at major crime scene”.

## **6.5 Refinement**

Evaluation and analysis of the imaging system has demonstrated the many benefits that the system can bring to the forensic and law enforcement communities. However, this has also brought to attention, limitations of the prototype imaging system and areas that can benefit from improvement. Key criticisms received through the questionnaire and structured interview has served to provide information regarding the best possible methods to refine and enhance the prototype. Improvements will essentially provide a more efficient and productive tool that meets the professional requirements for use in crimes scenes. Due to the time restraints, not all the recommendations that were proposed for the improvement to the imaging system could be put into effect. Nevertheless these will be discussed to provide guidelines for any future developments.

With the oversight in the workshop during construction of the panoramic head, the vertical rotation was restricted and as a result, the full capture of a spherical panorama was prevented. Correction of this error involves reconstruction and extension of the ‘L’ shaped section of the panoramic head to allow the full rotation of the vertical axis.

The number of components associated with the imaging system has been shown to affect the ease of assembly. By reducing the number of components, this will serve to provide a system that is easier to transport and assemble. This can be achieved by

integrating a number of components together such as the circuit box and the tripod. In addition, attachment of a hook to the tripod leg should provide adequate support for a laptop. These improvements will essentially remove the need for the platform by adaptation of the tripod. However, for this to be possible, another tripod must be utilised and be of sufficient robustness to withstand modifications to its structure and support all components of the system.

Minor refinements can often lead to considerable improvement within a system and therefore should not be overlooked. As discussed, the connection of the motors to the circuit box has resulted in some confusion during the setup of the hardware. This has been rectified through the use of colour coordination. Illustrated in Figure 6.12, the effects of colour coding the connectors from the stepper motors to their corresponding sockets on the circuit box can be seen to provide easier identification. Users are only required to match up the connections to their corresponding colour on the circuit box, thus removing the confusion in the identification of each motor.

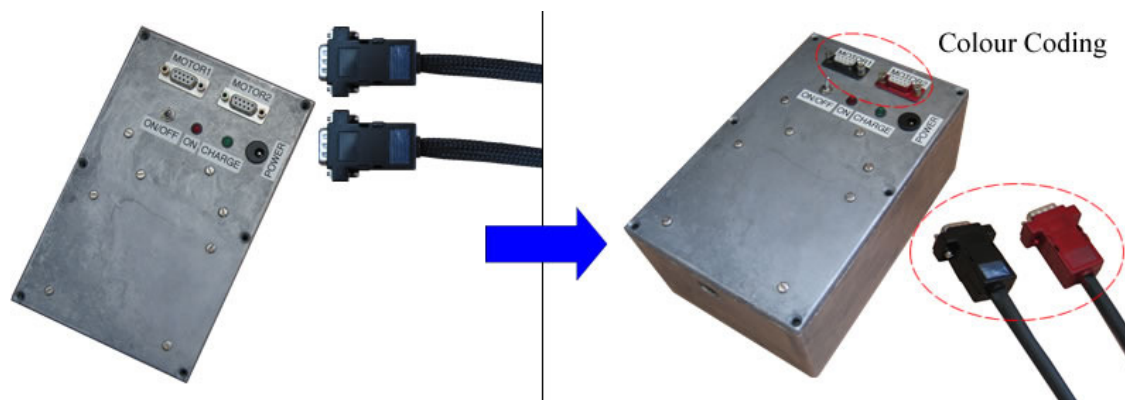

**Figure 6.3** – Colour Coding of Connectors and Sockets.

The type and length of the cable utilised for the connection of the motors to the circuit box was also brought to attention. The cable was considered to be inappropriate in length which resulted in excessive movement of the cable and thus movement within the captured images causing blurring of the resultant panoramas. The cables were measured and reduced in length to minimize movement but still adequate to allow unrestricted rotation of the panoramic head.

Prevention of contamination is a priority when dealing with a crime scene and any equipment utilised must minimise and eliminate any potential risk it may bring. A particular concern that was realised during the evaluation process was in reference to the textured cables that were used to connect the stepper motors to the circuit box. It was found that dirt and other contaminants can easily be trapped in the cable increasing the possibility of contamination to a scene. In addition, the texture of the cables prevents efficient and thorough cleaning of the imaging system and therefore would be insufficient for deployment in a crime scene. Illustrated in Figure 6.13, the replacement of the textured cable with a smooth cable serves as a method to overcome this drawback.

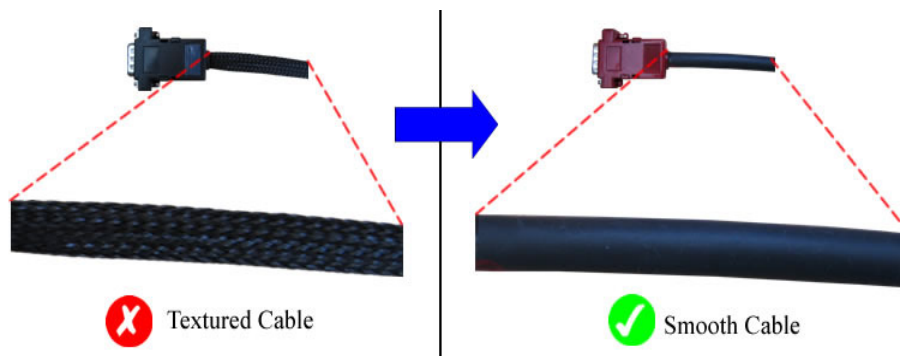

**Figure 6.4** – Replacement of the Cables.

The method of using a screw to attach the camera to the panoramic head has received some criticism. Difficulties were observed with handling the screwdriver while holding the camera in position. The use of a clip mechanism in place of a screw would provide the system with a faster and more efficient method of attaching the camera to the panoramic head. This can be achieved through adaptation of current clip mechanism used in standard tripods.

In addition, the position and orientation of the camera on the panoramic head caused some confusion, requiring constant reference to the tutorial to ensure correctness. In order to enable a quick identification of the camera's position, the outline of the camera is marked on the panoramic head to show its correct position. As illustrated in Figure 6.14, the position and orientation of the camera can be instantly achieved by alignment of the camera with the outline on the panoramic head.

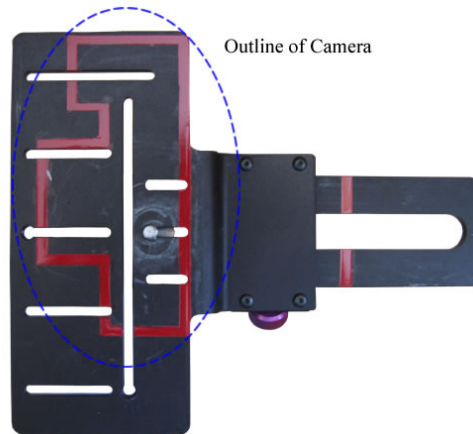

**Figure 6.5** – Outline Demonstrating Position of Camera.

The system's software required a complete overhaul of interface in terms of its options, and appearance. It was discovered that the original system's software appeared to be cluttered with information which resulted in a sense of confusion. Simplicity was an issue that was brought to attention a lot. In order to achieve this, the software interface was redesigned. Reduction in the number of stages from six to four was the first alteration applied to the software interface as well as the use of invisible tabs which appear when the stages are required. These avoid the impression of lengthy process and indicate the exact stage of the process more efficiently. The stages of the software were renamed to provide a better comprehension of what is involved in each stage.

Each stage of the software possessed instructions intended to guide the users through the process of operation. These were removed from each stage of the interface as the intuitiveness of the software itself should be self-explanatory and this also serves to simplify the interface by preventing clutter of information.

The front end of the user interface as illustrated in Figure 6.15 has been redesigned and renamed to 'Mode'; incorporating the 'Start' stage of the software and providing a more graphical introduction to the software. The lack of available option for the quick capture of a spherical panorama was made aware during the evaluation. This was rectified and added to the options that are available in the 'mode' stage through drop down menus. As discussed in section 6.4, the use of greyed out inactive buttons caused some confusion to the correct sequence of buttons in the software. This was dealt with

by use of invisible buttons which only appeared at correct stages of the software. This would essentially guide the user through the operation of the system's software.

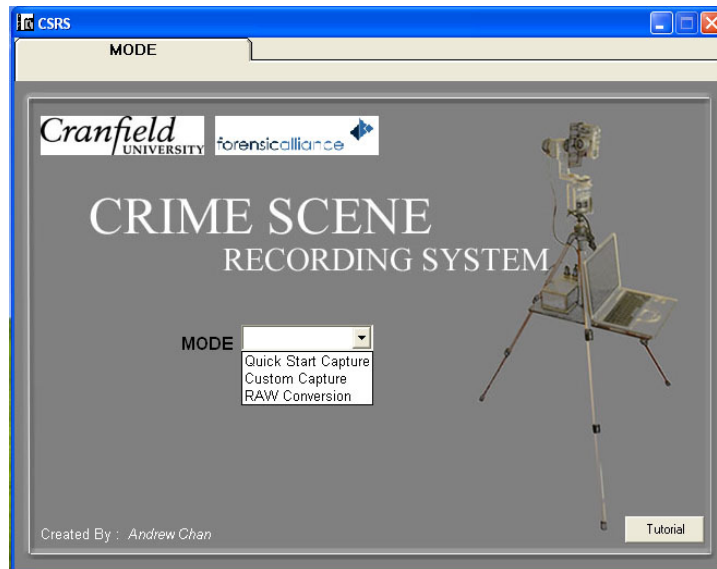

**Figure 6.6** – Front End of User Interface.

The previously named 'overlap' and 'vertical settings' stages have been united into the 'Settings' stage. As illustrated in Figure 6.16, it provides one location for users to select the percentage overlap as well as preparing the vertical axis for capture; thereby reducing the number of stages in the software.

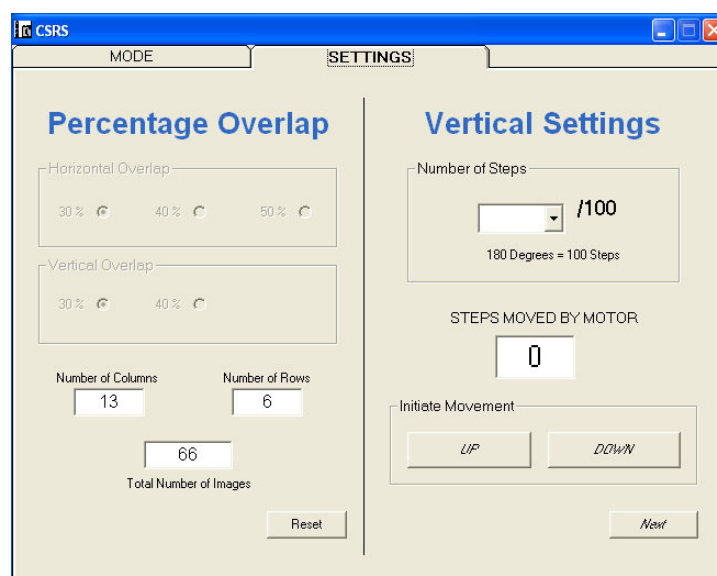

**Figure 6.7** – 'Settings' Stage.



The ability of the tutorial to efficiently communicate information to the user was put into question. One of the principal problems observed with the tutorial was its structure. Although the tutorial provided access to all information from one page, the numerous numbers of options confused the users. In order to provide a more logical structure, the tutorial was restructured by division into three categories: hardware, software and information, forming a hierarchy of information. In addition, the dimension of the tutorial's interface was reduced to a similar size to that of the system's software. This ensures that both the system's software and tutorial can be viewed correctly. The hardware section of the tutorial was found to be inappropriately structured. Users that needed to view a particular sections of the hardware tutorial again was faced with the prospect of viewing the entire hardware tutorial before reaching the particular section desired. This was solved by division of the hardware section into each stage of the assembly process. User can therefore view any stage as desired. With the refinements and improvements made to the imaging system as discussed in this subsection, some of the information within the tutorial no longer was valid. Therefore, any refinements made to the imaging system were translated to the tutorial (*The Supplementary CD presents the refined tutorial*).



## 6.6 Summary

This chapter has presented the trial and analysis of the prototype imaging system through its application in a simulated crime scene. Evaluation and structured interviews carried out with volunteers from key areas of the law enforcement and forensic communities have provided valuable information regarding the practicality of the imaging system. Concerns expressed during these trials have shown areas of the imaging system that can benefit from alterations, with the intentions to improve the usability and practicality of the system as a viable forensic tool.

## **Chapter 7: DISCUSSION**

### **7.1 Introduction**

This chapter discusses the results of the research based upon the chapters set out within the thesis. Discussion will first be focused upon current documentation techniques and the advantages and drawbacks that they bring to forensic and law enforcement work; giving cause for the development of the prototype imaging system. The benefits of digital presentation will be illustrated through reference to case law and case studies, placing focus upon their possibly acceptance within the judicial system. The development of the prototype imaging system will then be discussed, detailing the processes involved and the problems encountered during its construction. Detailed discussion on the evaluation and analysis of the system will be presented regarding its capabilities and practicalities as a forensic tool. The overall project will be assessed and the strengths, weaknesses of the imaging system identified.

### **7.2 Current Forensic Tools**

The need for the development of the prototype imaging system as described within the thesis has been accentuated by the drawbacks associated with current documentation techniques. The rapid development in IT has presented means of providing the forensic and law enforcement communities with additional capabilities to record and present the conditions of a crime scene with greater efficiency over current documentation techniques.

The purpose of crime scene documentation is to record all relevant physical evidence and document the conditions of a crime scene. As stated in section (3.2), “physical evidence encompasses any and all object that can establish that a crime has been committed or can provide a link between a crime scene and its victim or a crime and its perpetrator” [Saferstein, 2001]. Physical evidence can therefore be potentially any item within a crime scene that has or has not been already identified as such; and as a result presents a question to the investigator as to “the extent of photographic documentation required in a crime scene?” The current documentation techniques of notes, photography and sketches offer the investigator the ability to record the crime scene and

items within the scene that have been identified as being of evidential value. However, items that have initially been deemed irrelevant to an investigation can subsequently, through additional information become of significant importance. It then falls to the investigator to inspect each photograph captured to identify the item of evidence in question and establish its position within the scene. In a major crime scene, this can involve hundreds of scene photographs which are both difficult and time consuming to examine; requiring careful cross referencing to determine its relationship within the scene.

The inadequacy of traditional documentation techniques to efficiently illustrate spatial information of the scene and its evidence has resulted in investigators employing additional techniques such as video cameras to capture the scene. Although the use of video cameras provides valuable data, the captured scene is limited to the direction in which the camera is pointed and users are presented with linear playback. Poor visual resolution as discussed in subsection (3.4.3.3) further limits the value of video cameras in forensic science.

Thorough documentation of a crime scene is not only valuable during the course of an investigation, but also serves a vital role in the courtroom. The ability to communicate effectively the layout and conditions of a scene to the jury will allow a greater comprehension of the evidence presented during the trial. Current documentation techniques are on occasions limited in their ability to efficiently convey the scene to the jury. Since photographs present a 2D representation of a 3D world, the true spatial relationship of a scene cannot be fully appreciated with current documentation techniques. This is evident from some cases, where the transportation of the jury to the location of the crime scene is warranted to provide a better understanding of the scene and its evidence. This is both a time consuming and costly task to implement; its utilisation is therefore only beneficial with the most high profile cases.

This subsection has described the principles drawbacks associated with the current documentation techniques and shown the opportunity for an additional tool within the forensic and law enforcement community. Although, the three main crime scene

documentation techniques cannot be replaced, additional equipment and techniques will serve to enhance and strengthen the ability of personnel to represent and communicate the crime scene more effectively both during an investigation and within the courtroom.

### **7.3 Digital Presentation**

Medical, archaeological and architectural communities among various other professional bodies have long recognised the value of digital photography and presentation as a method to communicate information with more efficiency and accuracy. Its adoption within the forensic and law enforcement communities has been relatively more recent.

The use of digital photography to document crime scenes and evidence in the laboratory has been attributed to the many advantages it possesses over its conventional counterpart; the ability to provide an instant view of the capture image being by far the most cited. Adoption of this technology within the UK's forensic and law enforcement communities have been positive, with several organisations such as Dorset Police Constabulary essentially replacing traditional photography and operating solely on digital.

The value of CG presentation as a tool for experts to communicate evidence more efficiently in court has been well documented and established within the US. Its development within the UK has been relatively slower in comparison, but has made steady progress in recent years. High profile cases such as the 'Soham' murders have served to demonstrate the advantages and capabilities of this technology to a wider audience. Taking precedent from cases in the US have presented valuable information for its implementation in the UK; by identifying the advantages and issues that can arise from the use of CG presentation in court.

In order to gain an insight to the current situation of CG presentation in UK courtrooms, this technology was utilised in four real case studies. In collaboration with forensic personnel, the aim was to construct and provide the expert witness with a visual presentation that allowed the evidence of the case to be communicated to the jury

effectively in support of their testimony. Through utilisation of the CG presentations within the UK courts can the real benefits and issues that arise from its use be established. Although the construction of the CG presentation for each case study presented different requirements and challenges, the main objectives and procedures of construction remained unchanged. Lessons gained from each CG display served to provide guidelines for construction of an effective forensic presentation. The emotive natures of CG presentation along with other factors were identified as concerns during their construction and steps were taken to minimise their affect through a number of techniques. Despite the advantages that CG presentation imparts to the expert witness, it was found that the courtrooms where the trials were held were insufficiently equipped to display the presentations. This resulted in the transportation of the required equipment by the expert witness to and from the courtroom.

#### **7.4 Imaging system**

The aim of the imaging system is provide a semi-automated system to capture the images necessary for the construction of a panorama. This presents an additional documentation technique to the forensic and law enforcement communities with the intention not to replace but enhance the repertoire of tools available, thus allowing a greater efficiency and accuracy to be achieved. This section will discuss the process that was involved in the development of the prototype imaging system and its evaluation and analysis.

##### **7.4.1 Construction of the Proposed Imaging System**

The construction of the imaging system was divided into three stages of development: camera, stage and software. Requirements set out in subsection (2.4.1) and (5.3) served as guidelines for the choices of components utilised in the imaging system. Careful consideration was given to each component to ensure that the overall imaging system provided sufficient capabilities to achieve its purpose as a forensic tool. Through, analysis of the parameters associated with the components, valuable information regarding the system's ability were attained. This subsection discusses the construction of the imaging system based on the three stages of development.

#### **7.4.1.1 Camera**

Following a comprehensive search, the digital camera implemented into the imaging system was the Canon PowerShot G3. Specification matching key criteria's revealed the digital camera to possess sufficient capabilities in terms of the resolution, cost, control and format.

Construction of a panorama involves the acquisition of a series of overlapping images, stitched together to provide a seamless panorama. The number of images required is dependent not only on the percentage overlap desired but also on the FOV of lens. Through calculations based on the specifications of the camera, the FOV of lens was established thereby indicating the degree of intervals between each image.

The capacity of the camera to accurately represent a crime scene is vital to an investigation. Little value is gained in capturing images that provide poor visual detail which will affect its value as a forensic tool. The application of the Johnson's Criteria provided an assessment of the visual capability of the camera's lens. Based on three levels of discrimination, calculations were obtained regarding the minimal size evidence at a range of two metres that is of any value to an investigation. These values are based upon perfect conditions of a scene, and as such the actual value may be different. In addition, as the distance between camera and evidence increases, the ability of the camera to provide detail also diminishes. Placement of the nodes within close proximity aids in maintaining a high level of detail within a virtual scene.

Semi-automation of the imaging system partly requires the ability for communication between the computer and camera. The Canon PowerShot G3 possesses such ability which through the open source VB software has allowed the computer to acquire control over the camera and its functions. This removes the need for physical interaction with the camera and allows the settings, capture and transfer process of images to be initiated directly from a software interface.

The integrity of the images captured is vital in ensuring admissibility in court and reduce the possibility of challenges by council. The ability of the camera to capture

images in RAW format provides a fundamental component in the imaging system that aids in maintaining evidential integrity. RAW format signifies data directly from the camera's sensor with no post-capture processing; the user is therefore presented with the 'primary' images that can be stored on WORM media to prevent contamination.

#### **7.4.1.2 Stage**

The 'stage' section aims to provide a frame which accommodates all components of the imaging system and provide accurate movement and positioning of the camera. Divided into several sections, the utilisation of a low cost tripod forms the central component of the stage. Its primary purpose is to support the components of the imaging system and reduce the possibility of cross contamination, by ensuring that the tripod is the only parts in contact with the scene.

The use of a panoramic head is essential for the accurate capture of images for the construction of a panorama. Absence of this component will result in parallax of the captured images and consequently failure in the stitching process of the panorama. The prototype imaging system utilised a panoramic head which was constructed and adapted to the tripod. Through the process of trial and error, the nodal point of the camera's lens was also identified and indicated on the panoramic head. Oversight in the workshop during construction of the panoramic head resulted in insufficient length; restricting the complete rotation of the camera. The effect of this error was minimal in respect to the construction of a cylindrical panorama. However, this was more evident in a spherical panorama where the uppermost section of a scene cannot be captured. This can be resolved by the capture of several nodes to ensure that the absence of the section in panorama is present in another.

In order to provide accurate movement and positioning of the camera, stepper motors was utilised for each axis of rotation. This enabled the movement of the camera to specific point in its rotation, allowing for the capture of images necessary for the construction of a panorama. During testing of the components, it was discovered the stepper motors utilised provided insufficient torque to rotate the panoramic head efficiently. This was due to the combined weight of the panoramic head and camera

resulting in slippage of the motors; more evident in the vertical axis during upwards panning. The addition of a 25:1 ratio gear box to each of the stepper motors helped to resolve this drawback by enhancing and providing the necessary torque required for accurate and precise positioning of the camera.

The necessary step pulses required by the stepper motors to initiate movement are supplied by the stepper motor drive board which converts the signals received from the software to step pulses. The stepper motor drive board in addition to a rechargeable battery and circuitry to enable functioning is enclosed within a circuit box. This aids to consolidate all loose components together thus increasing portability and provide a central unit for the connections of wires. The use of a platform suspended over the leg brace of the tripod provided a stable area where the laptop and circuit box could be situated during its use. This serves not only a practical role but also one that prevents cross contamination of a crime scene by ensuring that the tripod remains the only part of the imaging system in direct contact with the scene.

#### **7.4.1.3 Software**

The main role of the software is to provide automation to the imaging system by acquiring control over the camera and the rotation of the steppers motors. Integration of these controls into a central user interface presents the user with the ability to operate the imaging system with a simple series of buttons. The system's software was divided into three stages of development: stepper motor control, camera control and user interface.

Adaptation of the open source VB software allowed the movement of the stepper motors to be mapped to capture of the required number of images. Due to the restricted rotation of the vertical axis, the movement of the stepper motors were carefully calculated to prevent the panoramic arm from striking the 'L' shaped based of the panoramic head and causing damage to the system.

The software control provided user with the ability to control a number of features of the camera including its settings, connection, capture and transfer of the images.



Adaptation of the supplied open source VB impart the software control with the ability to control the process of capture, essentially removed the necessity for physical interaction with the camera.

The final stage of software development involved combining the motor and camera controls into a central user interface. This provided a front end to the software whereby users are presented with a number of options regarding the type of panoramas, percentage overlap and exposure of the cameras; all attainable through the manipulation of the combined motor and camera controls. The concept of simplicity has been upheld throughout the development of the user interface. In an attempt to ensure that users were not confused and overwhelmed by the user interface, the number of options and stages were kept to a minimal. Utilisation of large buttons that appeared at specific steps within the stages of the software ensured that the user interface was intuitive, permitting users of any ability to operate with little difficulty. A tutorial accessible through the front end of the user interface provided information in support of the imaging system. Divided into three sections, the tutorial presented information concerning the assembly of the hardware, operation of the software and the underlying principles of the imaging system.

#### **7.4.2 Evaluation**

The development of the imaging system yielded a tool that provided semi-automated acquisition of images necessary for the construction of a panorama. The capacity of a panorama to communicate a scene effectively is one of the fundamental advantages of the imaging system. The value of the imaging system as a forensic tool can only be fully realised with its application to real world crime scene through forensic and law enforcement personnel. Due to uncontrollable circumstances, trial of the imaging system in real world scenario was deemed impractical and the numbers of volunteers available were limited. Nevertheless, application of the prototype imaging system in a simulated crime scene and the evaluation and analysis by a limited number of volunteers generated valuable data, which can be used to postulate on the possible acceptance and success of the imaging system. This subsection aims to discuss the information and practicality of the imaging system in a forensic context.

#### **7.4.2.1 Information**

The value of the imaging system lies in its flexibility as a technique to communicate information effectively. As a documentation technique, the imaging system provides photorealistic representation of the crime scene in the form of a virtual scene. This provides investigators the ability to pan around and evaluate the scene without the risk of disturbing the evidence. The continuity of a panorama provides valuable spatial information and aids to illustrate the relationship between the items of evidence and its scene. A role of the investigator involves the documentation of a crime scene as fully as possible. However, this can often be a difficult task to ensure that the scene is completely documented and all items in the scene are captured. A spherical panorama offers the investigators an additional tool whereby the entire scene from a particular viewpoint can be captured reducing the concerns of any evidence overlooked.

As a courtroom technology, the imaging system provides more than just a simple representation of the crime scene. Its ability to communicate spatial information is not only beneficial to the investigators but allow the jury to gain a better comprehension of any evidence in question. The utilisation of virtual scenes enables an expert witness to communicate and explain in any order the evidence to the jury in a clear and concise manner. In addition, the very nature of a graphical presentation such as a virtual scene serves to captivate the viewer to the evidence. Studies have shown that graphical evidence results in a greater retention of information presented to them as appose to written or verbal information.

#### **7.4.2.2 Usability**

Evaluation and analysis by forensic and law enforcement personnel provided valuable data regarding the usability and practicality of the imaging system as a forensic tool. The opinions conveyed during the evaluations served a vital role in allowing the components of the system to be scrutinised and improved for application in a forensic environment. There are many issues that can have a direct affect on the usability and this subsection aims to identify and discuss the features of the system that attributed to viable forensic tool.

The imaging system was constructed and developed under a fundamental concept of simplicity. An imaging system that is intuitive to the users will ensure successful operation and capture of the images required for a panorama. The process involved in ensuring simplicity of the imaging system can be related to hardware or software issues. These are discussed below:

- **Hardware Issues**

- *Number of Components* – The number of components associated with the imaging system was found to have a direct affect on the portability and ease of assembly. Enclosure of all loose components into the circuit box has served as a method to maintain minimal components.
- *Connections* – Evaluation of the imaging system revealed that users encountered difficulties in the assembly process due to the present of identical plugs and socket. Each stepper motor plug was colour coded with its corresponding socket to enable easy identification and remove the confusion that may be encountered.
- *Indicators* – Assembly of the imaging system involves the attachment and alignment of a number of components. To avoid the misalignment and positioning of these components, the system utilises visual indicator where users can clearly identify the position and orientation of components.

- **Software Issues**

- *Minimal Stages* – Minimising the number of stages in the software will ensure that the user is not overwhelmed with the process.
- *Sequence of Buttons* – The emergence of the buttons at particular areas of the stage will serve to guide the user through the interface and prevent confusion by concealment of the inactive buttons. This serves to present an intuitive interface whereby the user is guided through the software.
- *Size of Buttons* – The use of large size buttons attracts the focus of the user to the correct buttons and allows easy identification of the next step in the software.

- **Reset** – Providing a reset button that can be activated at any stage of the software is valuable in the event that incorrect settings have been selected. This avoids fears that users may have in operating the system's software by allowing the process to be restarted.
- **Resolution** – The software has been developed with dimensions suitable for viewing at low resolution. This ensures that the entire interface is viewable despite the resolution of the screen used.

The practical application of the imaging system as a forensic tool can be affected by many aspects. The ability of the imaging system to stand up to challenges regarding the integrity of the images acquired is critical if it is to be a viable court tool. The feature of the system to capture images in RAW format is valuable as an indication that no alteration to the data has been applied. The data as suggested by the SOP for digital images can then be written to WORM for storage.

A major concern of the imaging system for forensic use is the issue of contamination. With each equipment and personnel that enter a crime scene, the potential for cross contamination increases. Several issues were raised regarding possible refinements that can be made to further reduce the possibility of contamination. These included replacement of the stepper motor wires with a smooth cable to prevent dirt from being trapped and transported to the crime scene. In addition, loose components of the imaging system are contained within a seal circuit box allowing easy cleaning following each deployment.

## 7.5 Applications in Forensic Science and Law Enforcement

The possible value of a tool such as the imaging system can extend far beyond the capacity to provide just a simple representation of a crime scene. The imaging system does not aim to replace current documentation techniques, but to assist and enhance the investigator in performing their work more effectively and efficiently. The danger is that a list is compiled of all possible application of the imaging system which has little or no value in forensic science, or does not provide any additional benefits over current

techniques. This subsection will postulate on some of the possible forensic applications of the imaging system and discuss the benefits associated. These are:

- **Briefing Tool** – A major crime scene investigation can often involve numerous personnel. A capture of a panorama at the earliest stage of an investigation can be of great value, as a method to present information such as the layout and condition of the crime scene to all personnel involved in the investigation before they enter the scene. Its ability to be partially rendered and viewed at the crime scene can assist investigator in obtaining a greater understanding, which can result in a more focused approach and utilisation of resources. Through email, the virtual panoramas can also serve as a method for specialist personnel that are unable to attend the scene to view the layout and conditions and provide their expert advice to the investigation.
- **Archive** – The ability of a virtual scene to incorporate a wide range of media through the use of hot spots, provide a flexible and powerful tool for archiving all case related information into one logical folder. The technology renders superfluous the need to carry around vast number of still photographs and case notes. This allows the expert witness to access information with ease and efficiency.
- **Courtroom Tool** – A virtual scene presentation in court proceedings provides an improved tool by which to communicate and familiarise the jury to the general layout and conditions of the scene. The relationship between evidence and scene can be presented efficiently, allowing the jury to follow the course of the investigation with little difficulties. In major crime scenes, jurors can sometimes be transported to the scene to allow a better comprehension and understanding, which is both a time consuming and expensive task to undertake. The use of virtual scenes can essentially eliminate the need for this by presenting the jury with the ability to observe the scene as if they were actually present.

- ***Witness Confirmation Tool*** – Eye witness statements can provide valuable information during an investigation. The credibility and limit of these statements must be established to gauge its value in the investigation. A virtual scene of the location can refer the view that the witness had which would aid to support or disprove the witness statement.
- ***Recollection Assistance*** – Capture of the crime scene as a virtual scene essentially freezes and preserves the actual scene and provides a permanent record which can be referred to at any time. This is particularly important since the actual scene may have long been changed. When a crime goes unsolved for long periods of time, investigators can utilize the virtual scene as a method to recollect the case information. In addition to providing a valuable tool to the investigator, the virtual scene also allows witnesses to view the scene; refreshing their memory of the key areas of their statement.
- ***Training Tool*** – Training is an essential component in bringing all personnel to the level of ability that is required in their profession. With the police force, training now account for a significant portion of the budget [Howard, 2000]. Current methods of training involve the utilisation of full scale simulated scenes that are both labour intensive and costly to implement. A virtual scene presents another approach where the investigator can still acquire some of the vital training in evidence identification and analysis at a fraction of the cost.
- ***Security and Prevention*** – A virtual scene has the potential to provide police personnel with a layout of a scene prior to any security operation. This allows the scene to be analysed and appropriate measures to be taken in advance to minimize any flaws.

## 7.6 Project Analysis

This section identifies and examines the strengths and weaknesses associated with project within a forensic context.

### **7.6.1 Strengths**

- The project was founded in collaboration with a forensic body thereby ensuring the practical relevance of the project to the forensic profession.
- Evaluation and analysis of the capabilities of the prototype imaging system was performed with the intended end users who belong to the forensic or law enforcement community. Their views therefore hold significant weight which aids to provide an accurate indication to the potential value of the imaging system as a forensic tool.
- The aim of the imaging system is to integrate and extend the abilities available to investigators for the documentation of a crime scene. Used in conjunction with current documentation techniques, the imaging system serves to enhance the information and accessibility of a scene.
- The value of panoramas lies in its ability to represent spatial information of a scene and its evidence in such a way that cannot be achieved with current documentation techniques. Therefore, the imaging system fills an important niche in the repertoire of crime scene documentation techniques.
- The ability of the imaging system is not restricted to a simple representation of a crime scene but has potential to provide a wide range of application within the forensic and law enforcement communities.
- The process involved in operating the imaging system has been developed to be relatively straightforward to enable users of any ability to operate.

### **7.6.2 Weaknesses**

- The imaging system was evaluated in a controlled simulated crime scene environment and not in a real world crime scene. A simulated scene serves only to indicate the possible capabilities and operation of the imaging system. Differences between the two environments need to be considered when extrapolating the results of the research for real crime scene tools.
- Trial of the imaging system was only performed on two types of environments. The ability of the imaging system to perform in different types of scenes and situation is unconfirmed. An extensive trial is therefore required in a range of

different environments and scenes to determine and assess its reliability and functionality, thus giving credibility to the imaging system.

- The evaluation of the imaging system was performed with a limited number of personnel from two organisations. Although the data acquired from the evaluations provided valuable information, it provided no statistical relevance. It is therefore necessary for the evaluation of the imaging system to involve a statistically relevant number forensic and police personnel from a number of organisations.
- Capture of images for a panorama essentially freezes the scenes and the evidence it contains. However, if evidence within a scene is deemed inadmissible, the panorama is rendered invalid, since removal of items in the panorama is not possible.
- The current support for the use of digital presentation in UK courts is limited due to the lack of equipment available in most courtrooms. Unless courtrooms integrate the means to present CG presentation, the value of the imaging system will remain limited.

## **7.7 Summary**

This chapter has discussed the results obtained during the research project. It has analysed current documentation techniques which have raised issues regarding the need for the imaging system. The constructions of the imaging system based on its three stages of development along with their associated parameter were discussed to highlight the possible advantages and limitations. This was followed by a presentation of the overall finding of the trial and the evaluation of prototype imaging system that provided valuable information regarding its capabilities as a forensic tool. Finally, the strengths and weaknesses of the project were presented, to provide an overall assessment of the research project.



## **Chapter 8: CONCLUSIONS**

### **8.1 Introduction**

The project described in this thesis involves the use of low cost technologies to develop a viable forensic tool to aid and enhance the crime scene documentation process. Based upon the broad aim of the research project, the central research hypothesis was postulated. Development of research questions including key requirements of the system and points of concerns were established which aimed to drive the project forward and aid in development of a viable forensic tool. In order to address the proposed hypothesis as well as the questions raised, a number of research objectives were established; giving a structure and direction to the research.

This chapter aims to present the conclusion of this research thesis by drawing upon the literature review, results and discussions in order to establish if the research objectives and the research questions have been attained. In addressing the research criteria's, the final conclusion can be drawn with respect to the central hypothesis. This chapter also presents opportunities for future work in this area of research.

### **8.2 Accomplishment of Objectives**

A number of specific research objective were established at the beginning of the project, with the intention to provide a structure and denote the direction of research in order to achieve the aim of the project. This section examines each of the research objectives set out and draws upon the fundamental aspect of the research to conclude on the accomplishment of these objectives.

#### **8.2.1 Develop a Background Understanding of the Core Subject**

The development of a forensic tool for the purpose of crime scene documentation first involved obtaining a fundamental understanding of the current methods employed by forensic and law enforcement personnel. Extensive information concerning the three crime scene documentation techniques of notes, photography and sketches were discussed. This served not only to outline the strengths of these techniques but also highlighted weaknesses faced by investigators with their use. In identifying the

drawbacks of current documentation techniques, it reveals a possible niche in which the prototype imaging system can satisfy. These include:

- ***Spatial Information*** – The ability of current documentation techniques to present spatial information relies on careful cross referencing of information which is both a difficult and time consuming task. Photographs present a 2D representation of a 3D world, removing the ability to fully appreciate the spatial relationship of a scene and its evidence.
- ***Completeness*** – Current documentation techniques provide little assurance to the extent of coverage of a scene. The four corner approach of photography may still overlook certain areas of the scene that may transpire to be of significant importance to the investigation at a later stage.
- ***Courtroom*** – The documentation techniques provide the only opportunity for the jury to comprehend the conditions and layout of the scene. However, its ability to communicate the overall layout effectively is restricted by the static position of photographs and limited FOV of a single image.
- ***Logical Folder*** – Documentation of a major crime scene can involve hundreds of photographs and case notes. Attendance at court entails the expert witness to carry vast number of material which is difficult to manage especially upon cross examination.

### **8.2.2 Identification of the Current Issues Surrounding the Core Subject**

A detailed literature review on key issues surrounding digital technology for the purpose of forensic work has served to identify the possible issues that may arise from the implementation of digital technology as an additional crime scene documentation technique. Digital photography and VE have been the focus of the project, as the underlying technology of the proposed imaging system. Understanding the advantages and disadvantages of these core subjects will aid to illustrate the roles that the proposed imaging system may have within forensic science.

The advances in digital technology have instigated a gradual shift in the utilisation of digital photography as a replacement to conventional film photography. This is derived

from the many advantages that digital photography possesses over its conventional counterpart. These include:

- **Instant Evaluation** – Through a LCD screen on most digital cameras, the ability to instantly review the captured image is of great benefit to the investigator. Poorly captured images can be identified and recaptured to ensure adequate documentation of the scene.
- **Direct Printing** – Photographs captured can be transferred to a computer for storage or printed directly for viewing. This removes the need for a chemical photo laboratory required by conventional film photography which is both a costly and time consuming process.
- **Precise Duplication** – The nature of digital information represents that a copy of an image is a precise duplication with no loss in quality between generations. This is a great benefit of digital technology which is not shared by its conventional counterpart which is analogue in nature which provides an inferior copy.

The technology involved in the construction and delivery of panoramas lies at the core of the prototype imaging system. Its ability to deceive the eyes into a 3D perception allows the viewer to examine a scene as if they were actually present. There are many methods available for the construction and display of a panorama; which differ in terms of FOV and quality. The methods selected for implementation into the prototype imaging system are:

- **Construction** – Specialised equipment exist which makes the process of constructing a panorama easier but can be expensive and suffers from low resolution. The prototype imaging system utilises a standard low cost digital camera in conjunction with the single and multi-row technique which allows for a high resolution panorama at a fraction of the cost.
- **Display** – QTVR software was utilised by the imaging system to display the resultant panoramas. QTVR was identified as being one of the market leaders in the field of interactive panoramas.

The value of CG presentations as a method to communicate information more effectively in court has slowly gained recognition with the UK. The US has been at the forefront in the use of CG presentation and the established case laws have provided reference for its use in the UK. The emotive nature of CG presentation and ease of manipulation has been the leading argument for the misused of such technology in court. Laws governing the use of digital images in courts have illustrated the conditions that must be satisfied for admissibility in court to be possible.

### **8.2.3 Investigation of Case Studies**

A wide range of computer graphics were used as aids to the presentation of evidence in court. The four cases presented all involved complicated evidence distributions that often required specific objects or features to be moved. These included the graphical mapping of fibre distributions for 1:1 fibre tapping from a murder victim. This was the first time that 1:1 fibre tapping had been presented in a UK court. CG mapping of fibre distribution was found to have clear advantages when presenting this complex evidence in court, allowing contact between the victim and assailant to be inferred.

Use of Computer graphics for the presentation of real cases in court has shown first hand, the potential value and impact that CG presentation can bring to forensic work. These cases have served to highlight the potential problem that may arise from its use but also provided guidelines that aid in the admissibility of the presentation in court. Despite the advances in technology, courts where the cases were held were found to be ill-equipped to accommodate and display the digital media.

### **8.2.4 Development of a Prototype**

A prototype imaging system was developed with the capabilities of capturing images necessary for the construction of a panorama. The design of an imaging system based on the Johnson Criteria, a simple set of rules originally constructed for military imaging, which allowed lens types to be defined for specific resolutions and FOV. Although simple in both its concept and application the resulting images were very favourably received during subsequent user trials.

Particular attention was placed on the parameter of each components utilised in the development of the prototype. This allowed the capabilities and limitations of the prototype imaging system to be assessed. The digital camera selected on its merits to provide high quality images and an array of controls that could be controlled through a computer lies at the core of the automation process.

The combination of the stepper motors and gear boxes provided an accurate and precise positioning of the camera; and provided sufficient holding torque for the camera to capture the necessary images for a panorama. This precision of the motors is evident from the resultant panoramas which stitched together with little difficulty. The construction of the panoramic head and the ability to adjust the nodal point has been successful as shown in the absent of parallax in the stitching process.

The design of the system's software is based on the concept of simplicity. Its aim is to automate the process of capture and allow users of any ability to operate the software with minimal complications. In light of the diverse range of computer skills possessed by users, subsequent evaluation revealed little difficulties encountered. This was achieved through careful structuring of the software and providing an intuitive and simple interface.

#### **8.2.5 Evaluation of Prototype**

The evaluation of the prototype imaging system involved a two step approach. Performance of the imaging system was evaluated by trial in a simulated crime scene. Replicating the conditions of a real crime scene as closely as possible served to demonstrate the functionality of the system in the same environments that it was designed for. Deployment of the prototype system in the simulated crime scene resulted in the capture of the necessary images for a cylindrical and spherical panorama. Successful stitching and construction of the panoramas demonstrated the ability of the system to perform as intended and avoid the effect of parallax. Additional case related information such as detailed images were added to the panoramas through hot spots. This illustrated the potential of virtual scenes as more than just a simple representation of a scene.

Evaluation of the imaging system was carried out with a group of law enforcement personnel. This provided relevant information regarding the performance and value of the prototype imaging system as a forensic tool. Through the use of questionnaires and structured interviews, the opinions from each individual were collected and analysed. User feedback revealed that the following factors are important in this type of equipment:

- **Quality** – The panoramas should be of sufficient quality to accurately depict the scene and its contents.
- **Ease of Assembly** – The components of the system should allow easy and quick assembly of the imaging system.
- **Ease of Operation** – The system's software should allow users of any ability to operate with little difficulties.
- **Minimal Contamination Issues** – For the purpose of forensic work, the issue of contamination is vital. The imaging system should allow easy cleaning following each deployment to prevent dirt and contaminants to be transferred to another scene.
- **Portability** – Users of all sizes and gender will be required to transport the equipment to the scene. The weight of the system therefore needs to be manageable.
- **Robustness** – The imaging system needs to be able to tolerate the constant transportation to and from scenes.

These factors were accommodated in the design by:

- Integration of a high quality digital camera into the imaging system has ensured that any image captured is of sufficient quality. Application of the Johnson's criteria provided a quantitative analysis of the digital camera, presenting the minimal size object that is of any value to an investigation.
- The number of components of the imaging system was found to have a direct impact on the ease of assembly. By maintaining the number of components to a minimal, it not only ensured an easier assembly of the system but also simpler

transportation. Colour coding of the connectors and their corresponding sockets have allowed users to quickly identify and connect the proper stepper motors.

- The addition of a tutorial in the software provides users with information regarding the imaging system from the assembly of the hardware and operation of the software to the underlying principles of the technology. The aim is to communicate clear and concise instructions to the user in a form of graphical illustrations.
- An important factor in the development of the system's software is simplicity and intuitiveness. In combination, these will allow users of any technological ability to operate with little difficulty. The software was kept to a bare minimum to avoid cluttering of information which can overwhelm the user. This was achieved by placement of invisible buttons on the interface which appeared and became active at specific stages of the software. This not only served to maintain a simple interface but also presented the user with a guide through the software. It has been recognised that the technological knowledge of users are often diverse. The software presents an option for a quick start; essentially removing the need for the user to select any technological options.
- Prevention of contamination is vital in a forensic environment. Some of the precautionary measures taken have included the use of smooth cables and enclosed circuit box which can be wiped down easily following each deployment. Through suspension of all components on the system, it ensured that the three tripod legs were the only part of the imaging system in direct contact with the scene

The evaluation and assessment of the prototype imaging system provided valuable information which aided in the refinement and improvement of the system. User feedback revealed that the utilisation of the imaging system as a forensic tool was viable, justified by the benefits it brings to their work. The interactive nature of a virtual scene and its ability to represent the spatial information of a scene is of particular value which cannot be attained with current documentation techniques. It provides investigators with information regarding the layout and conditions of the scene, which can be assessed and discussed before determining the correct course of action. This

serves to focus resources and prevent numerous personnel entering and potentially contaminating the scene.

The cost of the imaging system was shown to be extremely low especially when compared to the commercially available systems; costing in the region of twenty times more. The low cost imaging system therefore makes the desire to equip every major incident van with the system a viable option.

### **8.3 Accomplishment of Central Hypotheses**

The research hypothesis postulated in this thesis was as follows:

“Through the utilisation of low cost IT, the visual presentation of information will be of significant benefit to forensic science in particular for the recording of evidence and its presentation in court. If a scene could be captured in such a way that offers the viewer the ability to move freely, as if he or she were present at the actual scene, it would be advantageous at various stages of an investigation from the initial crime scene to the courtroom”.

Through the achievements of the research objectives and strict adherence to the requirements of the system, the results of the research have shown a positive response to the hypothesis. The research project yielded a low cost imaging system that captured images for the construction of a panorama. This enabled users the ability to view a scene as if he or she was present which not only showed potential for application as an investigative tool but also valuable for communication of information in court.

### **8.4 Recommendations for Future Work**

The results of the research thesis have shown the potential value of the imaging system and the niche that it can occupy within the forensic and law enforcement community. This section outlines several ways in which the work described in thesis can be continued and built upon to further explore and establish the concept.



- **Evaluation** – In order to determine the true potential of this type of technology within the law enforcement communities, there is a need to trial the imaging system in real world crime scenes with a statistical relevant number of forensic personnel.
- **Acceptance** – Discussions between barristers and the law enforcement community to determine any possible implication that can arise from the use of this type of CG presentation in court is required. This should then be trialled in court to demonstrate its potential.
- **Guidelines** – A set of SOP should be established for the utilisation of the imaging system as a method to maintain the integrity of any evidential material captured by the system.
- **Automation** – At present the prototype imaging system provides a semi-automated process of capture which still requires a degree of human interaction. The need for selections to be made concerning the type of panorama and settings of the camera as well as preparation of the panoramic head for capture requires familiarisation of the software and time to operate. Future work should involve fully automating the imaging system so that capture of the images can occur with a single button; removing the necessity to prepare the panoramic head or input settings to the software.
- **Integrity** – Techniques that can add to the integrity of the evidence is valuable tool. Uses of encryption as a form of preventing manipulation provide some assurance to the evidential integrity. Further research into authentication of images is warranted to increase the credibility of the imaging system.
- **Faults** – With the evaluation of the imaging system, a number of concerns and faults were identified. In order to demonstrate the full potential of the imaging system, the concerns and faults must be addressed and rectified.

## 8.5 Summary

This chapter has summed up the results of the research by assessing the achievements of the research objectives. This has served to demonstrate and support the central research hypothesis of the project. In addition, future work has been purposed as a way to push forward this type of technology within the forensic and law enforcement communities.

## **GLOSSARY OF ABBREVIATIONS**

1:1	One-to-one
2D	Two Dimensional
3D	Three Dimensional
IT	Information Technology
CAD	Computer Aided Design
CCD	Charged Coupled Device
CDSDK	Canon Digital Camera Software Development Kit
CG	Computer-generated
CMOS	Complementary Metal Oxide Semiconductor
CITU	Crash Investigation and Training Unit
CPR	Civil Procedure Rules
CPU	Central Processing Unit
CSI	Crime Scene Investigation
DV	Digital Video
DVD	Digital Video Disc
FA	Forensic Alliance
FOV	Field of View
FRE	Federal Rules of Evidence
GBVR	Graphic Based Virtual Reality
HFOV	Horizontal Field of View
IAI	International Association for Identification
IBVR	Image Based Virtual Reality
ICSRS	Interactive Crime Scene Recording System
IPIX	Interactive Pictures Corporation
ISO	International Organisation for Standardisation
JPEG	Joint Photographic Experts Group
LCD	Liquid Crystal Display
LED	Light Emitting Diodes
OCX	OLE Control Extension

PACE	Police and Criminal Evidence Act
PC	Police Constable
PPI	Pixels Per Inch
PSDB	Police Scientific Development Branch
QPS	Queensland Police Service
QT	QuickTime
QTVR	QuickTime Virtual Reality
R2S	Return to Scene
REVEAL	Reconstruction of Virtual Environments with Accurate Lighting
SOCOs	Scene-of-Crime Officers
SOP	Standard Operating Procedures
TIFF	Tag Image File Format
TVP	Thames Valley Police
UK	United Kingdom
USA	United States
USB	Universal Serial Bus
VB	Visual Basic
VE	Virtual Environment
VFOV	Vertical Field of View
VR	Virtual Reality
WORM	Write Once Read Many

## REFERENCES

- [Aaland, 2003] Aaland, M. (2003). *Shooting Digital*. Sybex. ISBN: 0-7821-4104-8.
- [Adams, 1998] Adams, D. (1998). *Setting the Scene*. Police Review. 3 April. Page 24-25.
- [Advanced Imaging and Analysis, 1998] Advanced Imaging and Analysis. (1998). *Photography in the Digital Age, Part I: Film vs. Digital – Is One Best for you?*. Application Notes. Volume 1 Number 4. November.
- [Advanced Imaging and Analysis, 1999] Advanced Imaging and Analysis. (1999). *Photography in the Digital Age, Part II: Photographs and Digital Images in the Courtroom*. Application Notes. Volume 2 Number 1. January.
- [Anti, 1993] Anti, D.R., Seif, S.S. (1993). *Demonstrative Evidence can be Most Effective When it is Kept Simple*. The National Law Journal. Aug 2. Page32-33.
- [APRI, 1999] American Prosecutors Research Institute. (1999). *The Dirt on Digital*. American Prosecutors Research Institute. Volume 8 Number 3.
- [Azcarate, 2000] Azcarate, P. (2000). *Digital Imaging: The Technology and the Prosecutor*. The Prosecutor Magazine. Volume 34 Number 1. January/February.
- [Baldwin, 1998a] Baldwin, H.B. (1998a). *Three Dimensional Imaging in Crime Scene Investigations*. SPIE Conference on Investigation and Forensic Science Technologies. Volume 3576. November. Page 2-6.
- [Baldwin, 1998b] Baldwin, H.B. (1998b). *Crime Scene Interpretation: Back to Basics*. SPIE Conference on Investigation and Forensic Science Technologies. Volume 3576. November. Page 2-6.

[Bardelli, 1994] Bardelli, E.J. (1994). *The Use of Computer Simulations in Criminal Prosecutions*. Wayne Law Review. Volume 40 Number 3. Pages 1357-1377.

[Benton, 2002] Benton, P., del Rosario, M., Shen, Y.L. (2002). *Using Immersive 360 Degree Images to Enhance Active Involvement and Comprehensive in the Learning Process*. Society for Information Technology and Teacher Education International Conference (SITE). Volume 2002 Issue 1.

[Berg, 2000] Berg, E.C. (2000). *Legal Ramifications of Digital Imaging in Law Enforcement*. Forensic Science Communications. Volume 2 Number 4. October.

[Biehl, 1999] Biehl, C. (1999). *Ensuring the Integrity of Digital Images*. Police Chief. June.

[Blitzer, 2002] Blitzer, H.L., Jacobia, J. (2002). *Forensic Digital Imaging and Photography*. Academic Press. ISBN: 0-12-106411-5.

[Borelli, 1996] Borelli, M. (1996). *The Computer as Advocate: An Approach to Computer-Generated Displays in the Courtroom*. Indiana Law Journal. Volume 71 Number 2.

[BSI, 2000] BSI. (2000). *Photography – Electronic still picture cameras – resolution measurements, BS ISO 12233:2000*. ISBN: 0-580-36452-6.

[Chapman, 1994] Chapman, D.P., Deacon, A.T.D., Hamid, A. (1994). *Hazmap: A Remote Digital Measurement System for Work in Hazardous Environments*. Photogrammetric Record. Volume 14 Number 83. Page 747-758.

[Chan, 2002] Chan, A. (2002). *Advanced Imaging of Bullet Striations*. No 4 Forensic Engineering and Science MSc Thesis. Cranfield University. July.

- [Chen, 1995] Chen, S.E. (1995). *QuickTime VR – An Image-Based Approach to Virtual Environment Navigation*. Computer Graphics (SIGGRAPH 95' Proceedings). Page 29-38.
- [Chen, 1998] Chen, D.Y., Ho, M.C.C., Ouhyoung, M. (1998). *Video VR: A Real-Time System for Automatically Constructing Panoramic Images from Video Clips*. ISBN: 3-540-65353-8. Page 140-143.
- [Cherry, 2003] Cherry, M. (2003). *Reasons to Challenge Digital Evidence and Electronic Photography*. The Champion Magazine. Page 42.
- [Chiang, 1997] Chiang, C.C., Huang, A., Wang, T.S., Huang, M., Chen, Y.Y., Hsieh, J.W., Chen, J.W., Cheng, T. (1997). *Pano VR SDK – A Software Development Kit for Integrating Photo-Realistic Panoramic Images and 3-D Graphical Objects into Virtual Worlds*. Proceedings of the ACM Symposium on Virtual Reality Software and Technology. Page 147-154.
- [Coyle, 2004] Coyle, T., Larkin, A., Smith, K., Chan, A., Hunt, N. (2004). *Fibre Mapping – A Case Study*. Science & Justice. Volume 44 Number 3. Pages 179-186.
- [Crown, 1988] Crown. (1988). *Criminal Justice Act 1988: Chapter 33*. The Stationery Office Books. ISBN: 0105433888.
- [Cuntz, 2002] Cuntz, N., Klein, J., Krokowski, J. (2002). *Realtime Navigation in Highly Complex 3d-Scenes Using JPEG Compression*. Proceedings of GI-Informatiktage.
- [Curtin, 1999] Curtin, D. (1999). *A Short Course in Choosing & Using a Digital Camera (Short Courses)*. ISBN: 1928873006.

[D'Angelo, 1998] D'Angelo, C. (1998). *The Snoop Doggy Dogg Trial: A Look at how Computer Animation will Impact Litigation in the Next Century*. University of San Francisco Law Review. Volume 32 Number 3. Pages 561-585.

[Duerr, 2004] Duerr, T.E., Beser, N.D., Stasiunas, G.P. (2004). *Information Assurance Applied to Authentication of Digital Evidence*. Forensic Science Communications. Volume 6 Number 4.

[Dyk, 1993] Dyk, T.B., Castanias, G.A. (1993). *Daubert Doesn't End Debate on Experts*. The National Law Journal. Aug 2. Pages 17-20.

[Fisher, 2000] Fisher, B.A.J. (2000). *Techniques of Crime Scene Investigation*. (6<sup>th</sup> Ed). CRC Press. ISBN: 0-8493-8119-3.

[Garnier, 2002] Garnier, Y. (2002). *The Virtual Reconstruction of Crime Scenes Using Digital Imaging*. No 4 Forensic Engineering and Science MSc Thesis. Cranfield University. July.

[Gibson, 2000] Gibson, S., Howard, T. (2000). *Interactive Reconstruction of Virtual Environments from Photographs, with Application to Scene-of-Crime Analysis*. ACM Symposium on Virtual Reality Software and Technology. October. Page 41-48.

[Girvan, 2001] Girvan, R. (2001). *Computer Animations used in Litigation*. Forensic Science Society Newsletter. July 4-5.

[Gower, 2004] Gower, P. (2004). *Court in the Act*. Police Review. Volume 112 Number 5787. August. Pages 25-26.

[Hall, 2002] Hall, V. (2002). *The Comparison of Traditional and Digital Photography in the Recording of Crime Scenes*. No 4 Forensic Engineering and Science MSc Thesis. Cranfield University. July.

[Hempel, 2003] Hempel, C. (2003). *The Scene of the Crime: Why TV Police Shows are a Public Menace*. The Boston Globe Magazine. February 9.

[Horten, 1994] Horten, M. (1994). *Graphic Evidence*. Solicitors Journal. Page 1289.

[House of Lords, 1998] House of Lords. (1998). *Digital Images as Evidence*. Select Committee on Science and Technology. Fifth Report. February.

[Howard, 2000] Howard, T.L.J., Murta, A.D., Gibson, S. (2000). *Virtual Environments for Scene of Crime Reconstruction and Analysis*. Proceedings of SPIE/IS&T. Volume 3960. January. Pages 41-48.

[Huang, 1997] Huang, H.C., Hung, Y.P. (1997). *Disparity Morphing and Automatic Generation of Stereo Panoramas for Photo-Realistic Virtual Reality Systems*. Technical Report 002, Academia Sinica, Taipei, Taiwan.

[Huang, 1998] Huang, H.C., Nain, S.H., Hung, Y.P., Cheng, T. (1998). *Disparity-Based View Morphing - A New Technique for Image-Based Rendering*. Proceedings of the ACM Symposium on Virtual Reality Software and Technology. Taipei, Taiwan. ISBN 1-58113-019-8. Page 9-16.

[Jacobs, 2004] Jacobs, C. (2004). *Interactive Panoramas – Techniques for Digital Panoramic Photography*. Springer. ISBN: 3-540-21140-3.

[Jenkins, 2003] Jenkins, R.B. (2003). *Module 381 Surveillance Systems – Johnson Criteria*. Cranfield University.

[Johnson, 1958] Johnson, J. (1958). *Analysis of Image Forming Systems. Proceedings of Image Intensifier Symposium*. U.S Army Engineer Research and Development Laboratories For Belvoir, Virginia. Pages 249-273.



[Kang, 1999] Kang, S.B. (1999). *A Survey of Image-Based Rendering Techniques*. Videometrics VI (SPIE International Symposium on Electronic Imaging: Science and Technology). Volume 3641. January. Page 2-16.

[King, 2002] King, S. (2002). Determination of the Source of Bloodstains. No 4 Forensic Engineering and Science MSc Thesis. Cranfield University. July.

[Kitchens, 1998] Kitchens, S.A. (1998). *The QuickTime VR Book – Creating Immersive Imaging on your Desktop*. Peachpit Press. ISBN: 0-2016-9684-3

[Krieger, 1992] Krieger, R. (1992). *Sophisticated Computer Graphics Come of Age – And Evidence will Never be the Same*. American Bar Associations Journal. December. Page 92-95.

[Lederer, 1994a] Lederer, F.I. (1994a). *Courtroom 21: A Model Courtroom of the 21<sup>st</sup> Century*. Court Technology Bulletin. Volume 6 Number 1.

[Lederer, 1994b] Lederer, F.I. (1994b). *Technology Comes to the Courtroom*. Volume 43. Page 1095-1122.

[Lederer, 2004] Lederer, F.I. (2004). Courtroom Technology: For Trial Lawyers, the Future is Now. Criminal Justice Magazine. Volume 19 Number 1.

[Lee, 2001] Lee, H., Palmbach, T., Miller, M. (2001). *Henry Lee's Crime Scene Handbook*. Academic Press. ISBN: 0-12-44-0830-3.

[Little, 2000] Little, C.Q., Small, D.E., Peters, R.R., Rigdon, J.B. *Forensic 3D scene Reconstruction*. In 28<sup>th</sup> Workshop: 3D Visualization for Data Exploration and Decision Making. Proceedings of SPIE. Volume 390. Page 67-73.

[Matson, 2004] Matson, J.V., Daou, S.F., Soper, J.G. (2004). *Effective Expert Witnessing – Practices for the 21<sup>st</sup> Century*. (4<sup>th</sup> ed). CRC Press. ISBN: 0-8493-1301-5.

[McCracken, 1999] McCracken, K. (1999). *To-Scale Crime Scene Models: A Great Visual Aid for the Jury*. Journal of Forensic Identification. Volume 49. Page 130-133.

[Miller, 2003] Miller, J.L., Wiltse, J.M. (2003). *Resolution Requirements for Alphanumeric Readability*. Society of Photo-Optical Instrumentation Engineers. Volume 43 Number 3. Page 1-6.

[Morley, 2002] Morley, S. (2002). *Virtual Reality Crime Scenes*. Vedette. Number 184. January. Page 20-21.

[Morton, 1992] Morton, M. (1992). *Court Decisions on Use of Facilitated Communication*. Facilitated Communication Digest. Volume 1 Number 1. November. Pages 6-7.

[Murray,1996] Murray, J.D., Vanryper, W. (1996). *Encyclopedia of Graphics File Formats*. (2<sup>nd</sup> Ed). O'Reilly & Associates, Inc. ISBN: 1-56592-161-5.

[Murta, 1998] Murta, A.D., Gibson, S., Howard, T.L.J., Hubbard, R.J., West, A.J. (1998). *Modelling and Rendering for Scene of Crime Reconstruction: A Case Study*. Proceeding of Eurographics. UK, Leeds. March. Pages 169-173.

[Narayanan, 1999] Narayanan, A., Penny, G., Hibbin, S., Lochun, S.K., Milne, W. (1999). *On Using Animations in Court*. Information & Communications Technology Law. Volume 8 Number 2. Page 151-163.

[Narayanan, 2001] Narayanan, A., Hibbin, S. (2001). *Can animations be safely Used in Court?*. Artificial Intelligence and Law. Volume 9 Number 4. Page 271-294.

[Noond, 2002] Noond, J., Schofield, D., March, J., Evison, M. (2002). *Visualising the Scene: Computer Graphics and Evidence Presentation*. Science & Justice. Volume 42 Number 2. Page 89-95.

[Nyland, 2001] Nyland, L.S., Lastra, A., McAllister, D.K., Popescu, V., Mccue, C., Fuchs, H. (2001). *Capturing, Processing and Rendering Real-World Scenes*. SPIE. Volume 4309. January.

[Obeysekare, 2000] Obeysekare, U., Egts, D., Bethmann, j. (2000). *Panoramic Image-Based Rendering Solutions for Visualizing Remote Locations via the Web*. Proceedings of SPIE. Volume 3905. Page 58-65.

[O’Flaherty, 1996] O’Flaherty, D. (1996). *Computer-Generated Displays in the Courtroom: For Better or Worse?*. Web Journal of Current Legal Issues. Number 4.

[Redsicker, 2001] Redsicker, D.R., Gordner, G., James, S.H., Laws, A.C., Redsicker, A.D. (2001). *The Practical Methodology of Forensic Photography*. (2<sup>nd</sup> Ed). CRC Press. ISBN: 0-8493-2004-6.

[Robey, 2000] Robey, D., Palmer, I., Chilton, N., Dabeedin, J., Ingham, P., Bramble, S. (2000). *From Crime Scene to Computer Screen: The Use of Virtual Reality in Crime Scene Investigation*. Proceedings of the 7<sup>th</sup> UK VR-SIG Conference. September.

[Russ, 2001] Russ, J.C. (2001). *Forensic Uses of Digital Imaging*. CRC Press. ISBN: 0-8493-0903-4.

[Saferstein, 2001] Saferstein, R. (2001). *Criminalistics: An Introduction to Forensic Science*. (7<sup>th</sup> ed). Prentice Hall. ISBN: 0-13-013827-4.

[Schofield, 2000] Schofield, D., Noond, J., Doyle, M., Goodwin, L., Fowle, K. (2000). *The Use of Forensic Animations in the Courtroom*. Proceedings of the ASPACI Road Safety–Crash Conference. 13-17 February.

[Silverman, 1993] Silverman, D.A. (1993). *Changing Times: How will Computers Impact Forensic Photography?*. Photo Electronic Imaging. Volume 36 Number 2 Pages 12-14.

[Staggs, 1999] Staggs, S. (1999). *Crime Scene and Evidence Photographer's Guide*. Staggs Publishing. ISBN: 0-9661970-3.

[Stewart, 2002] Stewart, P. (2002). *Forensic Science from the Crime Scene to the Courtroom*. Vedette. Number 184. January. Page 6-7.

[SWGIT, 2001] Scientific Working Group on Imaging Technologies. (2001). *Definitions and Guidelines for the Use of Imaging Technologies in the Criminal Justice Systems*. Forensic Science Communications. Volume 3 Number 3. July.

[SWGIT, 2002] Scientific Working Group on Imaging Technologies (2002) *Guidelines for Field Applications of Imaging Technologies in the Criminal Justice System*. Forensic Science Communications. Volume 4 Number 2. April.

[SWGIT, 2003] Scientific Working Group on Imaging Technologies (2003) *Recommendations and Guidelines for the Use of Digital Image Processing in the Criminal Justice System*. Forensic Science Communications. Volume 5 Number 1. January.

[The New York Times, 2004] The New York Times. (2004). *FBI Used Digital Copy of Print to Finger Wrong Man in Blasts*. The New York Times.

[Warlen, 1995] Warlen, S.C. (1995). *Crime Scene Photography: The Silent Witness*. Journal of Forensic Identification. Volume 45 Number 3. Page 261-265.

[White, 2004] White, P.C. (2004). *Crime Scene to Court – The Essentials of Forensic Science*. (2<sup>nd</sup> Ed). The Royal Society of Chemistry. ISBN: 0-85404-656-9.

[Wiggins, 2003] Wiggins, E.C., Dunn, M.A., Cort, G. (2003). *Federal Judicial Center Survey on Courtroom Technology*. Federal Judicial Center. December.

[Wright, 1998] Wright, P. (1998). *Beginning Visual Basic 6*. Wrox Press Ltd. ISBN: 1-861001-05-3.

## Internet

[Agosto, Accessed 2006] Agosto, B., Murray, M.T. (Accessed 2006). *Admissibility of Computer-Generated Animation*. Abraham, Watkins, Nichols, Sorrels, Matthews & Friend. URL:<http://www.abrahamwatkins.com/CM/Articles/Admissibility-Of-Computer-Generated-Animation.asp>.

[Allen, Accessed 2006] Allen, J. (Accessed 2006). *Technology in Court: A Brief Guide for Trial Attorneys*. URL:[http://ceb.ucop.edu/newsletter/v4/civil\\_pro.htm](http://ceb.ucop.edu/newsletter/v4/civil_pro.htm).

[Anderson, Accessed 2006] Anderson, G. (Accessed 2006). *Panoramas*. University of Waterloo, Canada. URL:<http://ist.uwaterloo.ca>.

[Answers.com, Accessed 2006] Answers.com. (Accessed 2006). *Digital Photography*. URL:<http://www.answers.com/topic/digital-photography>.

[Apple Computer, 2005] Apple Computer. (2005). *QuickTime VR*. URL:[http://developer.apple.com/documentation/QuickTime/InsideQT\\_QTVR\\_insideqt\\_qtvr.pdf](http://developer.apple.com/documentation/QuickTime/InsideQT_QTVR_insideqt_qtvr.pdf)

[Bergstein, 2004] Bergstein, B. (2004). *Digital Photography Poses Thorny Issues for Justice System*. USA Today. URL:<http://www.usatoday.com>.

[BBC News, 2003] BBC News. (2003). *Police Hail Forensic Breakthrough*. BBC News. URL:<http://news.bbcco.uk>.

[Canon, Accessed 2006] Canon. (Accessed 2006). URL:<http://www.canon.co.uk>.

[Charles, Accessed 2006] Charles, J.R. (Accessed 2006). *Converting Panoramas to Circular Images and Vice Versa – Without a Computer!*. URL:<http://www.eclipsechaser.com/eclink/astrotec/panconv.htm>.

[Christal, Accessed 2006] Christal, M. (Accessed 2006). *QuickTime Virtual Reality for Educators and Just Plain Folks*. The University of Texas at Austin. URL:<http://www.edb.utexas.edu/teachnet/QTVR/>

[DCA, Accessed 2006]. Department for Constitutional Affairs. (Accessed 2006). *Civil Procedure Rules*. URL:<http://www.dca.gov.uk>.

[DOAR, Accessed 2006] DOAR. (Accessed 2006). URL:<http://www.doar.com>.

[dpreview, Accessed 2006] dpreview. (Accessed 2006). *Digital Photography Review*. URL:<http://www.dpreview.com>.

[Eneate, 2003] Eneate. (2003). *Digital Images as Evidence in the Judicial Process*. Eneate. URL:<http://www.eneate.freemove.co.uk/evidence.PDF>.

[FBI Press Room, 2004] FBI Press Room. (2004). *Statement on Mayfield Case*. FBI Press Room. URL:<http://www.fbi.gov/pressrel/pressrel04/mayfield052404.htm>.

[Fried, Accessed 2006] Fried, R.B. (Accessed 2006). *Digital Photography: An In Depth Analysis of an Emerging Trend within the Computer Age*. URL:<http://www.crime-scene-investigator.net/digitalphotography-fried.html>.

[Gibson, Accessed 2006] Gibson, S., Hubboid, R., Howard, T., Murta, A., Sinnott, J. (Accessed 2006). *REVEAL*. URL:<http://aig.cs.man.ac.uk/research/reveal/reveal.php>.

[Girvan, 2001] Girvan, R. (2001). *An Overview of the Use of Computer-Generated Displays in the Courtroom*. Web Journal of Current Legal Issues. URL:<http://webjcli.ncl.ac.uk/2001/issue1/girvan1.html>.

[Hasselblad, Accessed 2006] Hasselblad. (Accessed 2006). *Hasselblad H2D*. URL:<http://www.hasselblad.com>

[Herrera, 1999] Herrera, F., Rodriguez, S.M. (1999). *Courtroom Technology: Tools for Persuasion*. URL:<http://www.ncsonline.org>.

[Hibbin, Accessed 2006] Hibbin, S. (Accessed 2006). *The Use of Animations in Court*. Exeter University. URL:<http://www.dcs.ex.ac.uk>.

[HIS, Accessed 2006] Hayden Switch & Instrument, Inc. (Accessed 2006). *HIS Stepper Motor Theory*. URL:<http://www.hsimotors.com/>.

[Hoey, 1996]. Hoey, A.L.L.M. (1996). *Analysis of the Police and Criminal Evidence Act s.69 – Computer Generated Evidence*. Web JCLI <http://www.mcl.ac.uk/~nlawwww/1996/issue1/hoey1.html>.

[Imaging Resource, Accessed 2006] Imaging Resource. (Accessed 2006). *The Imaging Resource Test Suite – More than you Probably Wanted to Know about Testing Digital Cameras*. URL:<http://www.imaging-resource.com/TIPS/TESTS/TESTS.htm>.

[Instro, Accessed 2006] Instro. (Accessed 2006). *Motorised Pan & Tilt Head*. URL:<http://www.instro.com>.

[IQTVRA, Accessed 2006] International QuickTime VR Association. (Accessed 2006). URL:<http://www.iqtvra.org>.

[Kaidan, Accessed 2006] Kaidan. (Accessed 2006). *How to Find Your Camera's Nodal Point*. Kaidan. URL:<http://www.kaidan.com>.

[Knoerlein, Accessed 2006] Knoerlein, D. (Accessed 2006). *Forensic Digital Imaging Passes Intense Legal Scrutiny; Frye Hearing: State of Florida vs. Victor Reyes*. URL:<http://www.foray.com>.

[Kodak, 1999] Kodak. (1999). *Digital Imagery in the Courtroom*. Kodak. URL:<http://www.ictlex.net/index.php/1999/10/05/digital-imagery-in-the-courtroom/> .

[Lawler, Accessed 2006] Lawler, B.P. (Accessed 2006). *QuickTime Virtual Reality – How to Make Panoramic Images*. URL:<http://www.imaging-resource.com/TIPS/LAWLER/PANOHOW2.PDF>.

[Levy-Sachs, Accessed 2006] Levy-Sachs, R., Sullivan, M., Hartford, C., Sarasota, F.L. (Accessed 2006). *Using Digital Photographs in the Courtroom – Considerations for Admissibility. Security Management Online*. URL:[http://www.securitymanagement.com/library/feature\\_August2004.pdf](http://www.securitymanagement.com/library/feature_August2004.pdf) .

[Li, Accessed 2006] Li, J., Tong, Y., Wang, Y., Shum, H.Y., Zhang, Y.Q. (Accessed 2006). *Image-Based Walkthrough Over the Internet*. URL:[www.ee.columbia.edu/~ywang/Research/ICVB2001IBWL.pdf](http://www.ee.columbia.edu/~ywang/Research/ICVB2001IBWL.pdf).

[m2w, Accessed 2006] m2w. (Accessed 2006). *Immersive Technologies*. URL:<http://www.m2w.net/Immersive/Immersive.html>.

[Mayo, Accessed 2006] Mayo, K. (Accessed 2006). *Digital-image Enhancement took a Print from “No Value” to “Identifiable” but Defense-attorney Accusations that the Technology was “Junk Science” Propelled that Print into the Hot Spotlight of Controversy*. Florida Division of the International Association for Identification. URL:<http://www.fdiai.org/articles/Photo%20Finish.pdf>.

[MaxIMT, Accessed 2006] MaxIMT (Accessed 2006). *Return 2 Scene*. URL:<http://www.maximt.co.uk>.

[McCarvel, 1995] McCarvel, R. (1995). *You Won’t Believe your Eyes: Digital Photography as Legal Evidence*. URL:<http://www.seanet.com/~rod/digiphot.html>.



[Morris, 2003] Morris, S. (2003). *Technology used to Simplify Evidence*. The Guardian. URL:<http://www.guardian.co.uk>.

[National Association of Criminal Defense Lawyers, Accessed 2005] National Association of Criminal Defense Lawyers. (Accessed 2005). *Lessons from the Brandon Mayfield Case*. URL:<http://www.nacd1.org>.

[National Crime Investigation & Training, Accessed 2003] National Crime Investigation & Training. (Accessed 2003). *Crime Scene Sketching*. URL:<http://www.ncit.com>.

[NIFS Australia, 2002] NIFS Australia. (2002). *After the Fact*. NIFS Australia. URL:<http://www.nifs.com.au/afterthefact/home.html>.

[Panoguide, Accessed 2003] Panoguide. (Accessed 2003). URL:<http://www.panoguide.com>

[Panoscan, Accessed 2003] Panoscan. (Accessed 2003). URL:<http://www.panoscan.com>.

[Pastra, 2001] Pastra, K. (2001). *Using Digital Photography as Judicial Evidence*. Sheffield University. URL:<http://www.dcs.shef.ac.uk>.

[Peace River Studios, Accessed 2005] Peace River Studios. (Accessed 2005). *PixOrb*. URL:<http://www.peaceriverstudios.com/pixorb/pixmain.html>.

[Photoxels, Accessed 2003] Photoxels. (Accessed 2003). URL:<http://www.photoxels.com>.

[PSDB, 2002] Police Scientific Development Branch. (2002). *Digital Imaging Procedure v1.0*. URL:<http://www.crimereduction.gov.uk>.

[Ressler, Accessed 2005] Ressler, S. (Accessed 2005). *Applying Virtual Environments to Manufacturing*. National Institute of Standards and Technology. URL:<http://www.itl.nist.gov>.

[Roark, Accessed 2005] Roark, J. (Accessed 2005). *Forensic Photography: The Pros and Cons of Going Digital*. Forensic Focus. URL:<http://www.forensicfocusmag.com/articles/3b1feat2.html>.

[Royal Canadian Mounted Police, Accessed 2003] Royal Canadian Mounted Police. (Accessed 2003). *Crime Scene Photography*. URL:<http://www.rcmp-learning.org>.

[Rutledge, Accessed 2005] Rutledge, P. (Accessed 2005). *Technological Aids to Prosecution*. URL:<http://www.aija.org.au>.

[Schiro, Accessed 2003a] Schiro, G. (Accessed 2003a). *Crime Scene Response Guidelines*. URL:<http://www.crime-scene-investigator.net>.

[Schiro, Accessed 2003b] Schiro, G. (Accessed 2003b). *Examination and Documentation of the Crime Scene*. URL:<http://www.crime-scene-investigator.net>.

[Schiro, Accessed 2005] Schiro, G. (Accessed 2005). *Collection and Preservation of Evidence*. URL:<http://www.tali.org/texasinv/evidence.htm>.

[Schofield, 2002] Schofield, D., Noond, J., Goodwin, L., March, J. (2002). "Interactive Evidence: New Ways to Present Accident Investigation Information". AIMS Research, SChEME, The University of Nottingham. URL:<http://www.cs.nott.ac.uk/~dzs/research/accident.pdf>.

[Selbak, 1994] Selbak, J. (1994). *Digital Litigation: The Prejudicial Effects of Computer-Generated Animation in the Courtroom*. 9 High Technology Law Journal 337.

[Shaw, 2002] Shaw, C. (2002). *Admissibility of Digital Photographic Evidence: Should it be Any Different Than Traditional Photography?*. American Prosecutors Research Institute. Volume 15 Number 10. URL:[http://www.ndaa-apri.org/publications/newsletters/update\\_volume\\_15\\_number\\_10\\_2002.html](http://www.ndaa-apri.org/publications/newsletters/update_volume_15_number_10_2002.html).

[Staggs, 2001] Staggs, S.B. (2001). *The Admissibility of Digital Photographs in Court*. URL:<http://www.crime-scene-investigator.net/admissibilityofdigital.html>.

[Stitcher, 2003] Stitcher. (2003). *Creating QuickTime 5 Spherical Panoramas*. Realviz. URL:<http://www.realviz.com>.

[Supreme Court of the United States, 1993] Supreme Court of the United States. (1993). *Daubert v. Merrell Dow Pharmaceuticals*, 509 U.S. 579. Supreme Court Collection. URL:<http://straylight.law.cornell.edu/supct.html/92-102.ZS.html>.

[Swarb. Accessed 2005] Swarb. (Accessed 2005). Civil Evidence Act 1995. URL:<http://www.swarb.co.uk>

[Taylor, Accessed 2005] Taylor, S.J. (Accessed 2005). *Attorneys Win Cases with Animations*. URL:<http://members.tripod.com/allanpsych/courtanimation.html>.

[TREC, Accessed 2003] TREC. (Accessed 2003). Johnson's Criteria for Pixel Resolution Four Levels of Discrimination. URL:<http://www.trec.com/johnsoncriteria.htm>

[UBISoft, Accessed 2005] UBISoft. (Accessed 2005). URL:<http://csi.ubi.com/index.php>.

[Virtual Reality Photography, Accessed 2004] Virtual Reality photography. Accessed 2004. URL:<http://www.vrphotography.com>.

[Widdison, 1997] Widdison, R. (1997). *Beyond Woolf: The Virtual Court House*.  
URL:<http://webjcli.ncl.ac.uk/1997/issue2/widdison2.html>.

[Wikipedia, Accessed 2005] Wikipedia. (Accessed 2005). *Virtual Reality*.  
URL:[http://en.wikipedia.org/wiki/Virtual\\_reality](http://en.wikipedia.org/wiki/Virtual_reality)

[e-consultancy, Accessed 2006] e-consultancy. (Accessed 2006). *Internet Statistics Compendium*.  
URL:<http://www.e-consultancy.com/publications/internet-stats-compendium/>

## APPENDIX A: Nodal Point

### A.1 Introduction

This appendix describes the nodal point of a lens and methods to identify its position. It also introduces the concept of parallax, its cause and effect on stitching of a panorama.

### A.2 Nodal Point

The nodal point of a lens is the point inside a lens where light paths cross before being focused onto the sensor as illustrated in Figure A.1 [Christal, 2002].

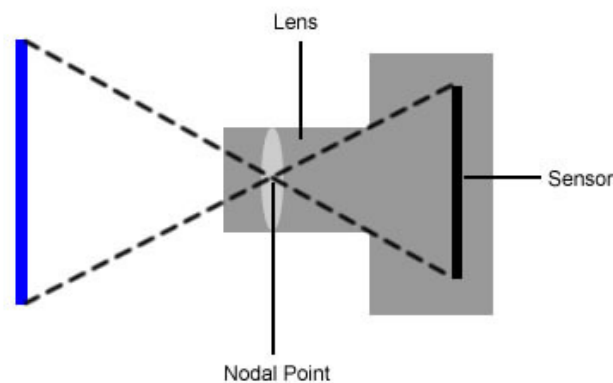

**Figure A.1** – Position of Nodal Point.

The rotation of the camera around its nodal point is vital when capturing photographs for the purpose of constructing a panorama. Incorrect rotation of the camera as demonstrated in Figure A.2 will result in what is known as parallax of the images.

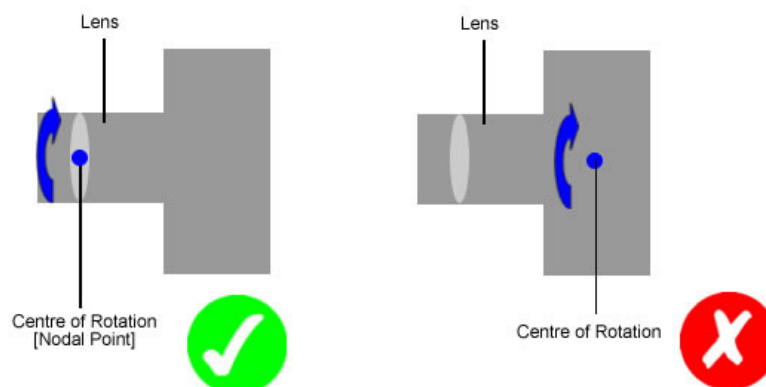

**Figure A.2** – Rotation of Camera.

This is an apparent shifting of foreground objects relative to background objects when you change your point of view position [Christal, 2002]. Figure A.3 illustrates the effect of parallax on photographs from different viewpoints.

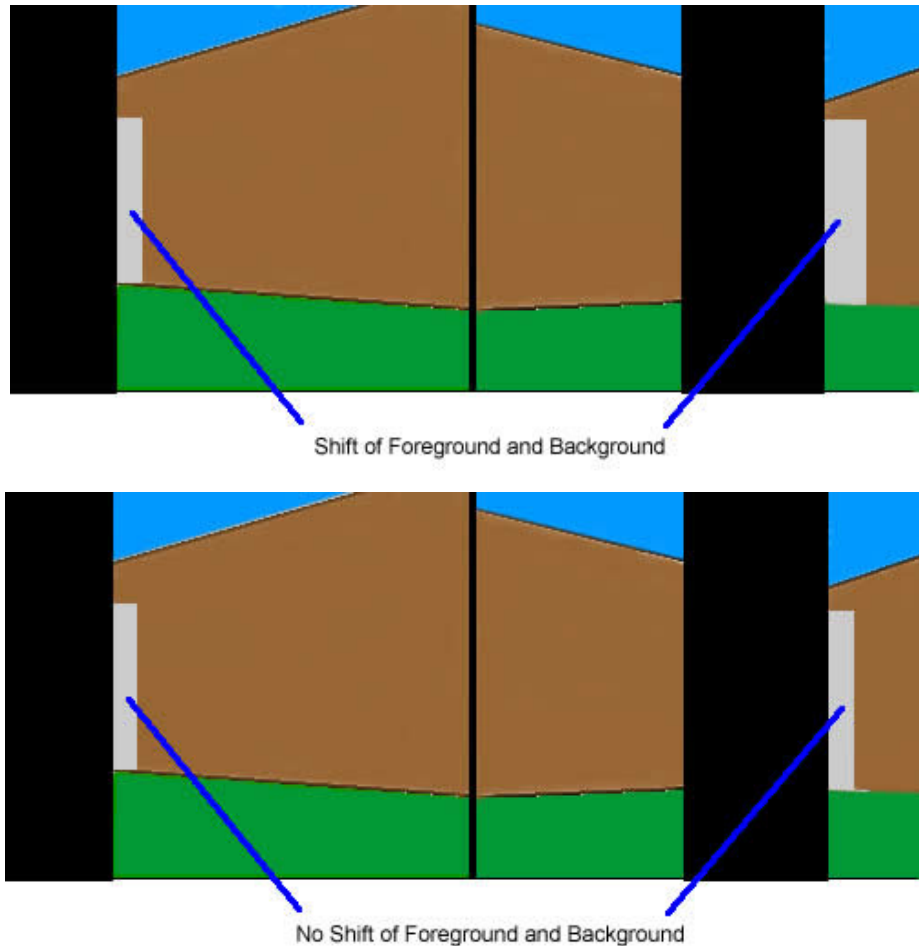
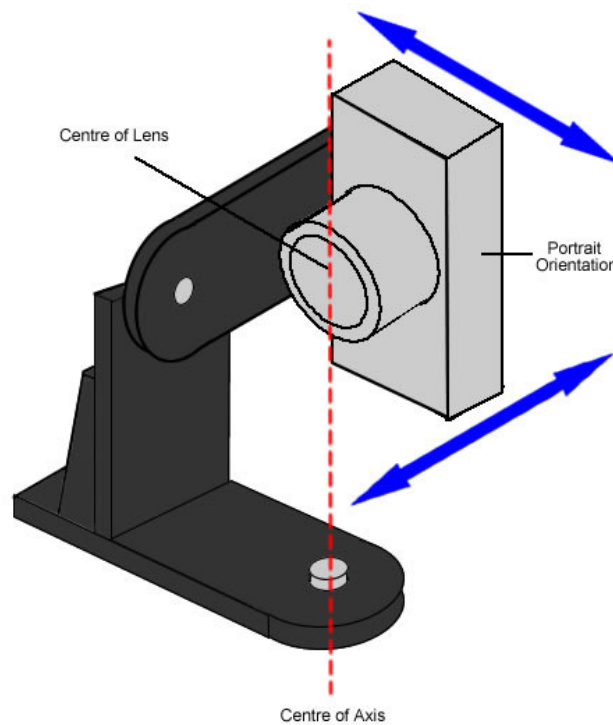

**Figure A.3** – Effects of Parallax.

Parallax of images can affect the stitching process of a panorama. An object that appears in two overlapping photographs will appear to have shifted relative to the background. As a result, during stitching of these photographs, misalignment of the objects will occur resulting in blurring or ghosting as it attempts to blend the object's shift with the background [Christal, 2002].

As discussed, positioning the rotation of the camera around the nodal point of its lens is essential when taking photographs for panoramas. However, the nodal point varies from camera to camera and its position is not indicated by the manufactures. Therefore

the identification of the nodal point is required before capture of images can commence. Determination of the nodal point is a two step process of trial and error. Mounting the camera on a pan head allows the position of the camera to be adjusted. The first step involves mounting the camera in a portrait orientation with the centre of the lens positioned directly over the pan axis as illustrated in Figure A.4. The next step entails adjusting the forward or backward position of the camera on the pan head in order to locate the nodal point. This requires observing the relationships of foreground and background objects. Once the nodal point of the lens is located, the foreground and background objects should remain stationary relative to one another as the camera is panned.



**Figure A.4** – Positioning of the Nodal Point.

## APPENDIX B: Evaluation of System

### B.1 Questionnaire

**Questionnaire**

Name: \_\_\_\_\_

- 1 **Do you consider the number of components of the imaging system to be:**  
Manageable      Unmanageable
- 2 **Do you consider the total weight of the imaging system to be:**  
Light      Heavy
- 3 **Do you consider the sturdiness of the imaging system to be:**  
Fragile      Robust
- 4 **Do you consider the assembly of the imaging system to be:**  
Very Easy      Very Difficult
- 5 **Do you consider the required time for setup of the imaging system to be:**  
Very Quick      Too Long
- 6 **Do you consider the operation of the imaging system to be:**  
Very Easy      Very Hard
- 7 **The layout and sequence of button on the user interface is intuitive.**  
Strongly Agree      Strongly Disagree
- 8 **The tutorial provides adequate information for the setup and operation of the imaging system.**  
Strongly Agree      Strongly Disagree
- 9 **Do you consider the navigation of a constructed virtual scene to be:**  
Very Easy      Very Hard
- 10 **Do you consider your computer skills to be:**  
Very Good      Very Bad
- 11 **Additional information**

Figure B.1 – Questionnaire.



**B.2 Structured Interview**

The questions posed during the structured interview with each volunteers are shown below. The questions aim to gather information concerning the current opinions on the utilisation of digital and traditional photography.

**1) PERSONAL DETAILS :**

- 1.1 Name
- 1.2 E-mail
- 1.3 Organization
- 1.4 Area of Expertise

**2) DIGITAL AND TRADITIONAL PHOTOGRAPHY**

- 2.1 How many digital camera does your department currently posses?
- 2.2 Have you ever used digital photography in your area of work? How often?  
(*Never/Always*)
- 2.3 Do you use digital photography at crime scene or within the laboratory?
- 2.4 Have you used digital photographs in court?
- 2.5 Have you encountered any problems with the use of digital photography
- 2.6 What are the reasons for not using digital photography?
- 2.7 In comparison to traditional photography, what value do you think digital photography has in the area of Forensic Science? (*No Value/Equal Value/Greater Value*)
- 2.8 What advantages do you see digital photography providing over the use of traditional photography that are beneficial to your work?
- 2.9 Can you see digital photography making traditional photography obsolete?
- 2.10 How do you see digital photography evolving in your department?

**3) CURRENT DOCUMENTATION TECHNIQUES**

- 3.1 Notes, sketches and photography have formed the principle techniques used in the documentation of a crime scene. Do you consider current documentation techniques to be adequate to the needs of today's crime scenes?  
(*Inadequate/Adequate*)

- 3.2 Are there any areas of the current crime scene documentation techniques that require updating?
- 3.3 Do you consider communicating the relationship between the evidence and its layout in a scene with current documentation techniques to be: (*Very Difficult/Very Easy*)
- 3.4 Have you experienced any difficulties in attempting to communicate the layout of the scene in court?
- 3.5 Visual aids utilized in court are an advantage in communicating complex information in layman's terms. Do you: (*Strongly Disagree/Strongly Agree*)
- 3.6 Have you used any form of visual aids in court?
- 3.7 The use of visual aids improves the juror's concentration and recollection of the evidence presented to them in court? Do you: (*Strongly Disagree/Strongly Agree*)

**4) CRIME SCENE RECORDING SYSTEM (CSRS)**

- 4.1 Is there a specific part that makes the portability of the system difficult?
- 4.2 A compromise between the weight and the sturdiness of a system is often required. What do you consider of greater value: (*Lighter frame/Robust System*)
- 4.3 What difficulties did you encounter during the setup of the system?
- 4.4 As with all crime scenes, it is important to document the crime scene as quickly and thoroughly as possible before subsequent investigation begins and the crime scene is disturbed. How does the CSRS measure up to current techniques in terms of the time required to document the crime scene? (*Very Slow/Very Fast*)
- 4.5 Is the time required to capture a scene feasible to employ at a crime scene?
- 4.6 Can you perceive any type of crime scene that the deployment of the system would not be appropriate?
- 4.7 The resultant images from the system provide an overview of the crime scene. Do you consider this to be: (*No Use/Very Useful*)

- 4.8 Can you see the system becoming a technique to complement current documentation techniques?
- 4.9 How accurate does the resultant panorama represent the true crime scene? (*Inaccurate/Accurate*)?
- 4.10 Is the clarity (quality) of the panorama sufficient to accurately depict the evidence in the crime scene?
- 4.11 Does navigating the resultant scene produce a feeling of nausea?
- 4.12 How useful do you think the resultant panorama can be in court as a method of communicating the layout of the scene? (*No Use/Very Useful*)
- 4.13 In comparison to current documentation techniques such as sketches and photographs, do you consider the system to provide sufficient benefits to warrant its use in court over as a method to communicate the layout of the scene?
- 4.14 Relating evidence to the position it was found in the crime scene can often be difficult to convey. How useful do you think the CSRS is portraying this relationship between evidence and the crime scene? (*No Use/Very Useful*)
- 4.15 As a case progresses, case information collected over time often builds up to a unmanageable volume and recollecting a specific piece of information especially its relevance in a scene may be difficult; more so while giving evidence. How useful do you think the system is as a method of linking all case related information into one logical folder? (*No Use/Very Useful*)
- 4.16 The deployment of the system in a crime scene may present problems in terms of contamination of the crime scene or the integrity of the evidence collected; resulting in failure of the evidence to hold up in court. Can you perceive any issues which may be of importance?
- 4.17 Can you see the system being used in your department?
- 4.18 How much would you envisage a system such as this costing?
- 4.19 The system uses standard digital camera and low cost equipment therefore providing a low cost solution in representing a scene. It is the aim of the project to provide a low cost system where each responding crime unit has access to the system. How feasible do you think this aim is?
- 4.20 Do you have any experience or come across other similar systems?

- 4.21 Thought on the software interface?
- 4.22 Thoughts on the Tutorial?

## APPENDIX C: Equipment Specification

### C.1 Camera

The specifications of the Canon PowerShot G3 are:

- *Image Sensor* – 1/1.8 inch CCD.
- *Lens* – 7.2-28.8 mm.
- *Still Image Format* – JPEG or RAW.
- *Recording Pixels* – 2272 × 1704 pixels.
- *PC-Connected Shooting* – Available.
- *Shooting Mode* – Program, Shutter-priority (TV), Aperture-priority (AV) and Manual.



**Figure C.1** – Canon PowerShot G3.

### C.2 Stage

The stage comprises of several components including the tripod, panoramic head, motors and circuit box.

#### C.2.1 Tripod

SLIK U800 Tripod:

- *Operating Height* - 1.5m
- *Weight* - 1.5 Kg



Figure C.1 - SLIK U800 Tripod.

## C.2.2 Circuit Box

Connections:

- *Motor to Circuit Box* - 2 × '9' pin 'D' type sockets
- *Circuit Box to Computer* - USB 'A' to 'B' Male interface
- *Camera to Computer* - USB 'A' Male to Mini 'B' Interface

Circuit Box:

- Battery:
  - *Type* - Lead Acid Rechargeable Battery
  - *Voltage* - 6 Volt,
  - 9.5 amp/hr
- Softmark USB Stepper Motor Drive Board:
  - *Voltage* - 12 Volts
  - *Connection* - USB
- Circuitry – Figure C.3.

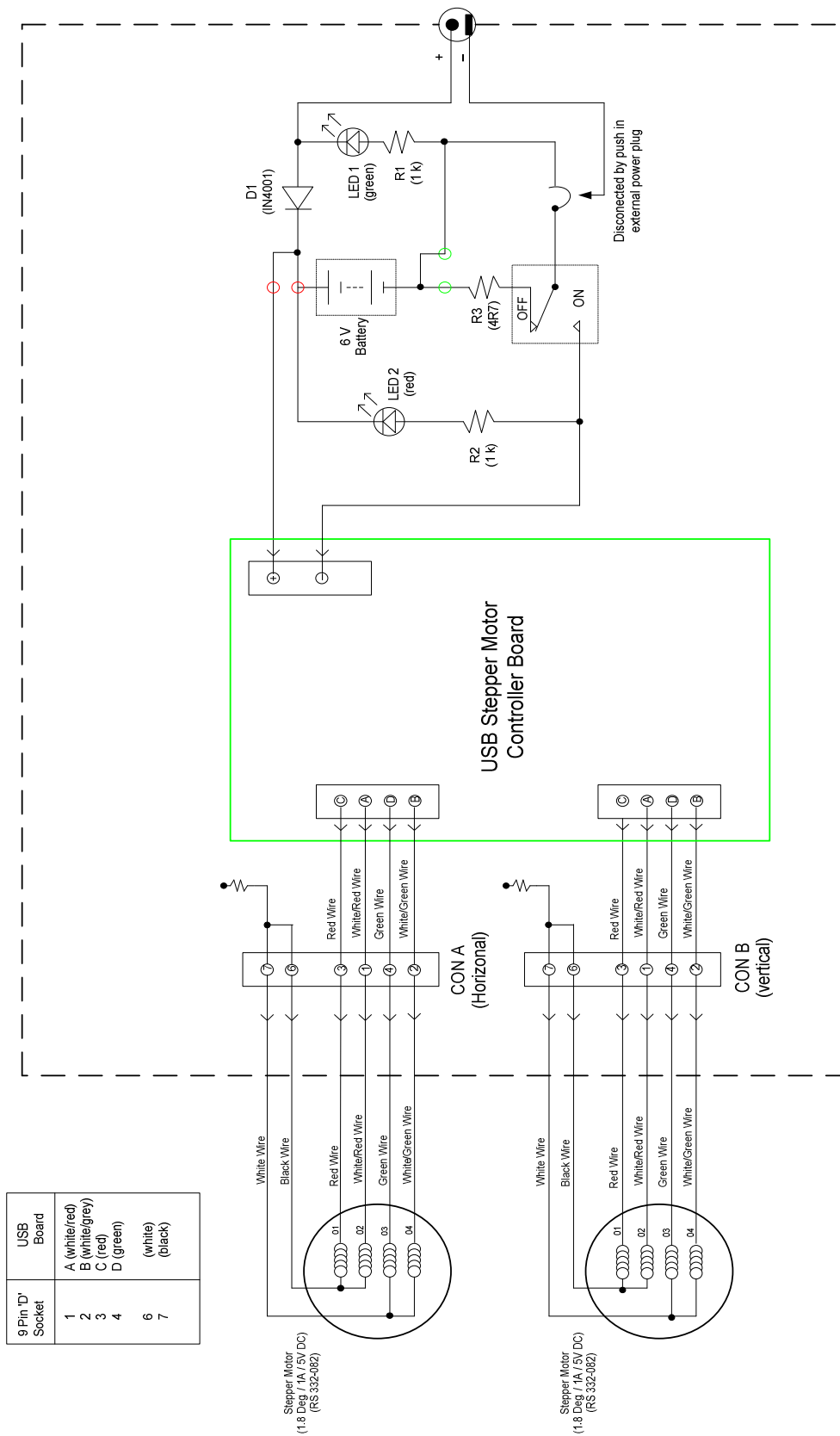

Figure C.3 – Circuitry of Circuit Box.

### C.2.3 Panoramic Head & Motors

RS (332-082) Stepper Motor:

- *Step Angle* - 1.8 degree
- *Voltage* – 5 Volts
- *Amp* - 1A
- *Weight* - 600g

RS (718-874) Gear Box:

- *Ratio* – 25:1

Panoramic Head:

- *Material* – Aluminium

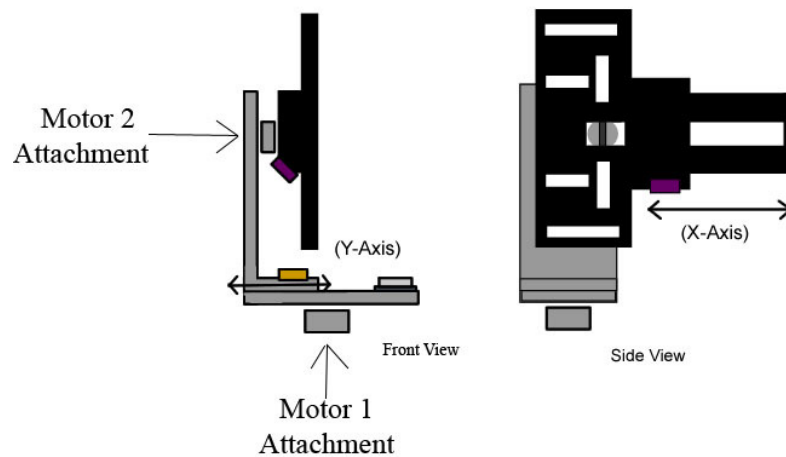

**Figure C.4 – Panoramic Head**

### C.2.4 Platform

- *Material* - Plywood

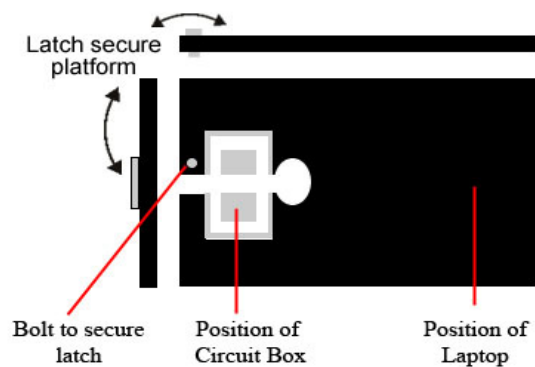

**Figure C.4 - Platform**



### C.3 Assembly of System

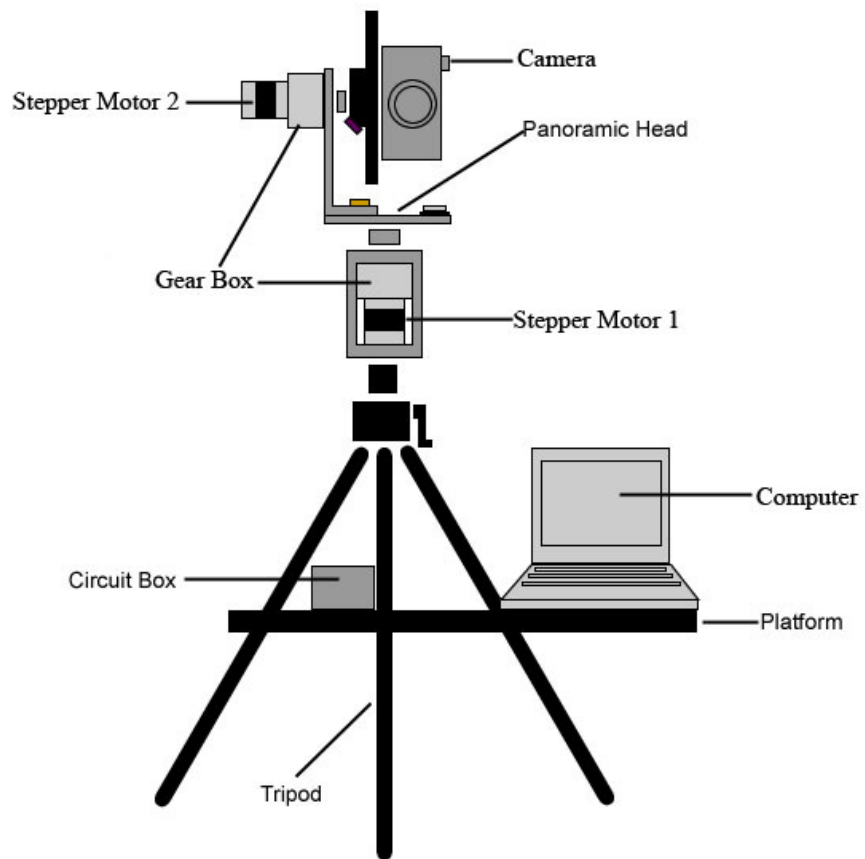

**Figure C.5** – Assembly of System



**Figure C.6 – Photograph of System**