

CoA/M/M+P-68



CoA Memo M and P No. 68

July, 1964

THE COLLEGE OF AERONAUTICS
Ergonomics - Systems Design Laboratory
CRANFIELD

ST. NO.
U.D.C. 30509
AUTH.

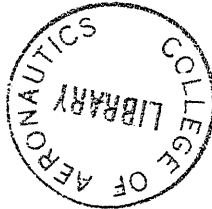

Project P. 15

- by -

D. Beavis
T.B. Leamon
R.H.D. Strank

Department of Production and Industrial Administration,
The College of Aeronautics,
Cranfield, Bedford.

30509

Summary

System synthesis and analysis procedures were used to arrive at various conclusions about separation of functions, allocation of functions and interface designs in a power station.

Members of the Group

D. Beevis (23)

H.N.C. (Aero. Mech. Prod.) Stud. I. Prod. E.

5 year apprenticeship at the National Gas Turbine Establishment.

T.B. Leamon (23)

B.Sc. Tech. (Chemistry) Manchester A.M.C.S.T.

One year with Ilford Ltd.

R.H.D. Strank (23)

B.Sc. (Physics) Imperial College, London.

One year with J. Lyon and Co. Ltd.



Contents

	<u>Page No.</u>
Summary	1
Members of the Group	1
Contents	2
Duration of Project	3
Acknowledgements	3
Introduction	4
System syntheses	7
Reconsideration of allocation of functions	15
Recommendations on Interface Design	19
Charge Engineers Console (side panels)	20
Charge Engineers Console (central panels)	22
Generator Board	24
The Bus Station Board	25
The Station Transformer Board	26
The Unit Board	26
The Bus Section	26
The Synchrosopes	26
Controls	27

Duration of Project

19 sessions of two hours each and additional work by individuals outside the group meeting.

Acknowledgements

The students would like to express their gratitude for the guidance of the project supervisor, W.T. Singleton and for the assistance provided very generously by the staff of Goldington Power Station, particularly Mr. Maskrey and Mr. Chapman.



Introduction

a) The Systems Design Philosophy

The purpose of this set of procedures is to facilitate the design of man/machine systems by formalising and structuring the decisions which must be made with particular emphasis on the rate of the human operator. Leaving aside the problems of hardware design this involves:

- Definition of objectives
- Separation of functions
- Allocation of functions
- Task descriptions
- Design of interfaces

The Task Description may be arrived at by synthesis from the functions or by analysis from the study of existing hardware. The purpose of the project was to provide the students with experience in applying these concepts to the design of a power station.

b) The Power Station

With the co-operation of the C.E.G.B. and the Station Superintendent at Goldington, Bedfordshire (Mr. J.H.W. Cope) it was decided to use Goldington Power Station as a source of information about power station operation in general and this station in particular.

Goldington is a 180 megawatt station with 6 x 30 megawatt units, (Unit implies 1 boiler and 1 turbine). This is smaller than the newer stations which are standardised at 4 x 500 megawatt units.

The generating station is under the overall control of the North Thames Division.

The requirement for each area is estimated by Grid Control (this is very detailed and is affected by meteorological situation and local conditions, such as 5,000 mealtimes). The National Grid Control also receives and correlates marginal unit production cost for each generating station. On economy considerations the production of power is allocated to the various stations. The price range in the North Thames is .16d/unit to over 3.0d/unit, Goldington cost = .38d/unit and for this reason is very nearly continuous running. That is, during daytime all six units are usually running. In considering unit costs, 5% is added to imported power for transmission costs.

Thus, National Control instruct North Thames how much power to generate. N. Thames gives detailed instructions, i.e. of time and unit, on running to the Shift Control Engineer. The Shift Control Engineer calls in the units via the Charge Engineer, who directs his Unit Operators and their assistants. Control of the station lies not with the Shift Control Engineer but with the Station Superintendent, through the Shift Charge Engineer. Frequency must

be a statutory 50 c/s. Thus, demand must always be anticipated. If demand exceeds production, frequency must fall. The steam inlet valves are controlled by governors, and open preventing further drop. However note: opening the governors will not restore frequency to 50 c/s. One unit operator controls 2 units, each unit requires 45 mins. running up time. No more than 3 units may be started at any one time. About 3 or 4 major breakdowns occur per annum mainly of 4/5 days duration. Apart from demand patterns the station is largely autonomous, having 260 employees, of whom 160 including operating staff are 'day staff', the remainder work on shifts. The skills of staff at Goldington are applicable anywhere in the Commission's Area. Water level is most critical, water carrying into the turbine will wreck it.

The operating criterion is cost in BTU/d which covers fuel cost, handling and maintenance costs, the station efficiency is now combined to give the marginal cost. Goldington is approximately 26.5% efficient.

There are several minor yet daily used control systems including C.W. Control, Soot Blowing, Oil Burning. The use of these is not automated and they are used at the discretion and experience of the Unit Operator.

Unit Operators and Charge Hand Unit Operators are equivalent to City and Guilds Standard, the Charge Hand normally being the higher of the two. The remaining technical staff are all H.N.C. standard and Charge Engineers are of Professional Institution standing.

Procedure

The project group were not presented with a specific design problem within the Power Station. The only terms of reference were those framed in the belief that a power station, which represents a system of considerable complexity, would provide a suitable area for the application of the Systems Design Procedure that has been evolved in the Ergonomics Laboratory of The College of Aeronautics.

It was realized that the design of a complete power station was beyond the capabilities of the project group in the time available although from an introductory visit it became obvious that there were many areas in which Ergonomics could make a useful contribution to the design of the station. Criteria for choosing the area of application of the problem were:-

- a) that it should be one in which the Systems Design procedure could make a useful contribution to the design of a Power Station.
- b) that it should be one of interest and potential gain of knowledge to the group members.

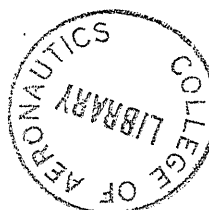

The area chosen for the investigation was the Control Function of the station including what, in the physical terms of the existing station, are the Unit and Central Control Rooms. This seemed the most promising area as the Control Function is a most important sub-system and handles a large part of the information flowing into the station.

The systems procedure of design by functional synthesis was to be used, in which an optimal design is synthesised and used as a standard for comparison with the existing system. It was realised that this would require a great deal of technical knowledge not immediately available to the members of the group, and that this lack might lead to some details and necessary interactions in the design being omitted. For this reason it was suggested that a Task Analysis might be carried out on the existing system in order to gather necessary data. Such an approach was rejected as a first stage, it was believed that by gathering information in this way the design of the optimal solution might be biased in terms of the existing design. It was hoped that any information could be collected, as and when required, from sources not necessarily connected with the station.

The synthesis procedure was valuable in providing insight into the necessary functions but it proved impossible to complete Task Description because of the complexities of the technology involved. For this reason the existing system was analysed by direct observation and the allocation of functions and interface designs were reconsidered in the light of this analysis.

System syntheses

a) Definition of objectives

For the Control Function of the Power Station these were defined as being:-

To ensure that the output of the station is geared to the requirements of the main grid system in the most economical manner possible. (This includes rectification of faults in the generating system as and when they occur).

From this definition a single block diagram was drawn of the control function (fig. A) together with a block diagram showing the relationship of this function to the rest of the system (fig. B). In this the remainder of the Power Station system has been grouped under the heading of Energy Transducer, the function of which is to convert stored solar energy into electrical energy. The objective of the control function is to manage the running of this complex transducer function.

b) Separation of functions

To examine what sub-systems are necessary in the control function to achieve its objective an attempt was made to specify the flow of information into and out of it. The information to and from Grid Control can be stated simply:

To Control
Future available capacity
(This includes inability to meet future requirements).

From Control
Future required output.
(Time, quantity, phase etc.)

The information flowing between the control and transducer is not so easily stated, and the control actions made to manage this complex system must first be specified. Control will be exercised either to achieve a required state of the system, or to prevent deviations from the required state. These required states of the transducer (in hardware terms a boiler and turbo-generator, plus auxiliaries) may be summarised as follows:-

Run Up
Shut Down
Increase Load
Maintain Load
Decrease Load
Accelerate (for Synchronising)

To achieve these states the control must vary the parameters of the fluid flows within the system (pressure, temperature, etc. of the Boiler Water/Steam, Air/Gas, Fuel/Ash and Cooling Water circuits). The only

independent variables for these fluids are their rate of flow, which determine their other parameters. The control must therefore compute the effect on these other dependent variables of any control action taken to change the rate of flow of a fluid. Having converted the requirements of grid control into the required changes in the physical state of the system, the control function must carry out the necessary control actions in advance of requirements, to allow for the large response lags of the physical system. In this way the changes of state will occur at the required time. The computation necessary to allow for the response time-lag is an important task of the control function, and the magnitude of these lags determine the sequence of control actions.

To investigate the control actions more closely the transducer function was expanded into several sub-systems (fig. C), and the inputs/outputs of these functions were categorised as follows:-

- 1) Electrical Energy
- 2) Rotational Energy
- 3) Gas (H.P. and L.P. steam, air and flue gases).
- 4) Water (boiler and cooling water).
- 5) Fuel.

The parameters necessary to specify the states of these fluids were listed in an attempt to determine what information was necessary to control the fluids. This led to the construction of a Matrix of fluid parameters/controlling actions necessary to achieve a given state of the system. In order to do this the parameters were separated into three categories:-

- 1) Those outside immediate control.
- 2) Those which may be controlled indirectly by varying other parameters.
- 3) Those which may be controlled directly.

This should have resulted in a graphical form of a Task Description for the Control Function, listing all the possible strategies open to achieve a required state of the system. An attempt was made to complete the matrix for the requirement 'Increase Load', but lack of sufficient knowledge of the operation of a power station prevented this being carried out satisfactorily. An outline operating procedure was obtained but because of the many strategies possible this was not of great assistance.

As little progress was being made at this stage the synthesis procedure was re-examined. It was apparent that the Control function can be divided into two categories:-

- 1) A control function necessary to monitor the state of the system (system monitor).
- 2) A function necessary to monitor the output of the system and match it to the requirements of Grid Control (Output Monitor), and that

the investigation had concentrated almost exclusively on the second of these due to the complexity of its control strategies. It was concluded that most suitable method of analysing it would be to formulate a mathematical method of the system and investigate the effect on the fluid parameters and the system output of all possible control strategies.

The distinction between the two control functions can be emphasised by the information they each require.

- 1) The System Monitor requires continuous information about the state of each transducer unit. For this reason, and in order to conveniently carry out control actions this function should be physically close to the transducer (boiler and generating) equipment.
- 2) The Output Monitor requires continuous information about the electrical output of each unit, and the total output of the station. It must deal in electrical terms since it has to communicate with Grid Control, and does not have to be physically close to the generating equipment. In fact, since it has to form an overall view of the state of the system, having it in close proximity to the generating sets could prove a distraction from the control task.

These requirements thus call for two separate control systems which correspond to the existing Unit and Central Control Rooms. Their relationship is shown in fig. D.

It was decided to concentrate the investigation on the Output Monitor (Central Control Room) in the absence of a suitable mathematical model for analysing the System Monitor Function.

The responsibilities of the two Control functions were listed as:-

<u>Output Monitor</u>	<u>System Monitor</u>
Monitors the output of individual generating units. Monitors the total output of operating units. Allocates electrical load between units. Synchronises unit output with the grid. Receives Grid Control Instructions. Receives notice of inability to meet required output (feedback from System Monitor).	Monitors the state of the units. Controls the physical state of the units. Assesses the feasibility of matching unit output to requirements. Inform Output Monitor of inability to meet requirements.
Notification of future available capacity to Grid Control.	Notification of future system state to Output Monitor.

(It was considered that, since the System Monitor is responsible for most parameters of the hardware it should also be responsible for synchronising. This would require only the normal System Hardware controls to be used plus some switching controls. However, there is a very close relationship between synchronising and other Output Monitor responsibilities and it was decided to retain Synchronising as an Output Monitor responsibility).

From these definitions, and the information flows shown in fig. 4, it was possible to specify the information flowing between the various functions of the system:

- I₁ Contains information about the required output of the whole station over a 24 hour period, plus corrections as they arise.
- I₂ Contains information about the required output of each generating unit over a period of 24 hours together with corrections as they arise.
- I₃ Contains the information necessary to achieve any desired state of the system.
- O₂ Contains information about the state of each unit.
- O₁ Contains information about the output of each and all generating units.
- O₃ Contains notice of future available capacity.
- O₄ Contains notice of and reasons for inability to meet future output requirements.

(The 24 hours notice of requirements specified for I₁ and I₂ is in order to compensate for the response lags of the system, and to allow minor maintenance work to be carried out).

Allocation of functions

The responsibilities allocated to the Control functions could conceivably be performed by automatic equipment, certainly so for the Output Monitor. However, the synthesis thus far has been developed from the original Definition of Objectives which is concerned with managing the Station under normal running conditions. It does not take account of non-normal operating conditions caused either by malfunctions of the generating plant or freak conditions in the National Grid. Such emergencies cannot be dealt with by conventional automatic control equipment, since it is not possible to foresee all such contingencies. Emergencies may jeopardise the safety of personnel, plant or the grid system, and it is very important that they should not be allowed to develop.

Thus, a further requirement of the Control System is that it should be able, if possible, to anticipate and deal with emergency situations. Such a task is best performed by a human operator with his ability to anticipate and diagnose faults, discriminate between multiple inputs and exercise judgement in problem solving situations. A human operator should also be used as a monitor, with override capabilities in automatically controlled systems. (See Human Engineering Guide to Equipment Design: Morgan, Cook, Chapanis and Lund), whilst routine control tasks are best performed by machines.

Thus, if all the control responsibilities could be performed by automatic equipment, it is necessary to retain human operators in both control functions. To allow for personnel contingencies and emergencies and to monitor the operator's performance at least two operators are required in each, and possibly more depending on the task load allocated to them.

System analysis

The analysis was carried out during two visits to Goldington and a subsequent meeting with Mr. Chapman. The system can be best examined under three headings and the analysis was carried out under these headings:-

- a) The equipment.
- b) The standard tasks.
- c) The necessary documentation.

In addition there is a non-standard part of the task consisting of the monitoring of the system in auto control. Much of this monitoring is presently performed by mechanical or electronic sense units and indicators: the continuation and possible extension of such monitoring is strongly recommended in view of the experimentally validated observation that in such a situation, namely low probability of occurrence of significant events, the human operator is unable to maintain a high vigilance level for lengthy periods.

Control adjustments indicated by the monitoring are identical with those necessary for starting up and for closing down a unit, they are described in section

a) The Equipment

A detailed list of all the equipment in the main control room was drawn up and the equipment detailed in a series of drawings. These drawings were used mainly as cases of the redesign of the interface (see later).

b) The Standard Tasks

The analysis was carried out by recording all the inputs to, decisions

and outputs from the two engineers in charge of the control room. These recordings were then analysed to determine necessary inputs-decisions-inputs for the two most comprehensive tasks and the results are shown here.

Starting up a unit

Note: The initial part of this description concerns station start up and is only necessary before the first set goes on.

Input	Decision	Output
Telephone from N.T. giving on time, number of machines.		1. Log the call and details.
Details in log	Order of m/c, i.e. merit or practical depending on previous performance. (Shift engineer).	Order of start up recorded.
Time	Prepare for starting up.	Plug sync. into socket, appropriate to the busbar in use, on Generator Board.
Unit telephones 'Ready to take load'	Raise volts on generator	Operate field rheo.
Generator volts just under Grid volts.	Voltages now 'match'.	Release field rheo.
	Check synchronous speed.	Switch on sync.
Synchroscope pointer in rotation.	Not synchronised . . . Increase <u>or</u> decrease synchronous speed of the set.	Open or Close governor.
Pointer study reaches T.D.C. in a clockwise manner.	Set synchronised with Grid.	Close circuit
Circuit closed	Apply load quickly	Open governor and 'inch'
Load reaches 5 m.n. as indicated on the vector.		Release governor

Input	Decision	Output
Governor released	Unit is ready for running load	Phone to N.T. advise the availability.
N.T. stipulates the demand		Demand into log.
Demand	Load required, i.e. usually demand + 2.	Phone unit and advise
Unit is prepared.	Increase load about 1 mw/min.	Open governor (1 flick = $\frac{1}{2}$ mw).
None (perhaps time)	Both nulls in and system is stable, i.e. ready for auto control.	Move transfer control from 'Hand' to 'Transfer'
Balancing meter not t.d.c.		Use either field rheo or A.V.R. to balance meter.
B. meter t.d.c.	Amplidyne is in correct setting for voltage.	Close transfer control to 'Auto' position.
Transfer control in auto position.	Automatic voltage Regulator in operation . . . cannot use field rheo.	Continue to open governor balancing the reactive in vector meter by A.V.R. control.
Output on vector = 10 mw.	Ready to transfer unit supply to unit.	Plug synchroscope into unit panel.
Unit volts less than transformer volts.	P.d. prevents circuits being switched.	Adjust A.V.R.
Unit board voltage = transformer volts.	Safe to switch	Switch in unit. Switch out grid.
Output < demand (on vector meter).	Increase load	Open governor.
Reactive \neq demand		Operate A.V.R.
<u>Taking Off a Unit</u>		
Shift Engineer phone the 'Off Order'		Record the order sets will come off in.

Input	Decision	Output
N.T. phone with required load and No. of machine.	From the off order decide which unit to take off.	Telegraph 'Shut Down' to correct unit. Log N.T. call.
In 2-3 minutes unit phones phones to indicate ready for take off.	Decrease load	Close governor adjust reactive with A.V.R.
Load = 5 mw.	Transfer unit aux. to grid.	Plug in sync. to respective unit transformer board.
	Sync. and switch to grid	
End of sync.	Continue to deload	Deload
= 5 mw load	Transfer to hand control	Move transfer control to 'Transfer'
In 'Transfer' condition	Balance	Centre balance meter by field rheo or A.V.R.
Balance meter t.d.c.	Transfer to Hand Control.	Switch to 'Hand'
Unit phones 'Ready' for off.		Deload to zero. Break circuit Run field volts off completely.
	Set off	Log time Phone N.T. and advise.

c) The necessary documentation

Considerable documentation is considered necessary and appears in the main to be concerned with two requirements, assessment of efficiency, but mainly for any post mortem. Since there appears to be ample time for the documentation and there appears to be no interference with the on line system, documentation and its use, or otherwise was not investigated further.

Reconsideration of allocation of functions

The necessary functions were established as:-

- 1) Select Action Required
- 2) Sequence Control Operations
- 3) Store Programme of Control Operations
- 4) Monitor System Performance
- 5) Store Desired Output
- 6) Store Past Performance Information
- 7) Record System Output.

Each of these functions was examined to establish whether, in the particular context of a Power Station, it was best performed by man or machine.

a) Select Action Required. This is basically a decision-taking process, acting on a multiplicity of input information. A wide range of possible actions is available. These factors suit the adaptability and flexibility of a human operator, rather than the rigidity of automatic control. It is true that certain actions, such as switching a unit on or off the Grid, are stereotyped responses to specific inputs, and these are suitable for automation. However, there will be situations in which human selection of action is essential, when the operator will need to be fully conversant with the operation of the system. The more practice the operator gets, the better will he understand the running of the system. Therefore, it is preferable to leave this function entirely to the human operator.

b) Sequencing and Programme Storage. Since these functions are so closely related, they were considered together. Essentially, they consist of producing a stereotyped series of responses to effect a desired control action. Expressed in such a way, it can be seen that these functions could be performed best by a machine. But again, considering emergency operations, the human operator may need to instigate sequences of control actions that do not conform to the stereotype. In this situation, he will need to understand the effect his actions will have, and this he can only acquire by performing the operations himself many times. Therefore, it is again preferable to use the human operator for these sequencing functions. But a human operator is not reliable as a store of control action programmes, he is liable to operate controls at the wrong time during routine operations. To overcome this conflict, it is recommended that the programme be stored in the control machinery in the form of safety interlocks, that will not permit control actions at inopportune moments (an example of this would be switching the auxiliaries power supply to the grid when the voltage were not correctly balanced). To provide for emergency operations, these interlocks should have manual overrides.

c) Monitor System Performance. This involves continual attention to all the parameters displayed, and advising the 'Select Action' function when prescribed limits are exceeded. Work on vigilance tasks has shown that human operators are very inefficient at such work. This is a clear case for using a machine, which is much better than a human operator. At present, much monitoring is automatic, employing warning lights and an associated buzzer. It is recommended that this system be extended to the dial displays. The method envisaged is that a buzzer will sound whenever a dial reading exceeds certain prescribed limits, and a light will indicate which dial needs attention. It is recommended that dial displays be retained, to assist the operator in building up a schema of the operation of the system.

d) Desired Output Store. This consists merely of taking in information and holding it unchanged over a period of time, this is better suited to a machine than a man. In this context, a piece of paper is considered as a 'storage machine'. Some work could be done on evolving the best form of this paper storage. A machine store is obviously needed to feed into the monitor.

e) Store Past Performance Information. The same conditions apply here as in d).

f) Record System Output. As in d) above, the holding of this information for a period of time is done better by machine than man. Also, the transcription of dial readings on to log sheets can be a considerable source of error. Therefore, automatic data transmission of some sort is recommended, either direct by landline, or via the medium of punched paper tape. Records kept at the station should be transcribed by hand as at present, to give variety in the human operator's task.

In the above discussion, great emphasis has been placed on the functioning of the system in emergencies. We believe that this is the correct emphasis, since if the system does not function in these conditions the cost in lives and equipment will be high.

Recommendations on separation of control functions

These recommendations have been arrived at from a theoretical approach and serve to validate the existing design rather than describe it.

1. That there should be two control functions in the Power Station -
 - a) An Electrical Output Monitor
 - b) A System State Monitor.
2. That the Control responsibilities should be allocated between the two functions as follows:-

Output Monitor

Monitors the output of generating units. Monitors the total output of the station. Allocates electrical load between units. Synchronises unit output with the grid. Receives notice of output requirements. Receives notice of inability to meet required output (from System Monitor). Notifies Grid Control of future available capacity.

System Monitor

Monitors the state of the generating units. Controls the physical state of the units. Assesses the feasibility of achieving output requirements. Inform Output Monitor of inability to meet requirements. Notifies Output Monitor of future state of system.

3. That a thorough analysis of the system Monitor Function be carried out using a mathematical model to investigate the effects on the state of the system of the many possible control strategies in order to determine the optimum control system.
4. That the System Monitor be adjacent to the boiler generating units.
5. That the Output Monitor be divorced from the area of the boiler/generator units.
6. That in both control functions automatic control equipment be used to perform routine control/monitoring functions.
7. That at least two human operators are included in each control function to monitor the performance of the system.
8. That the human operators be able to override the automatic control systems in all cases which would not jeopardise the system.

Recommendations on allocation of control functions

As a result of a functional analysis of the present Output Monitor, it became clear that all the functions at present carried out are necessary. Analysis of the allocation of these functions between man and machine showed that improvements could be made. The recommended changes here are:-

1. That a system of safety interlocks be built into the control machinery to prevent operation of controls at incorrect times.
2. That manual overrides be fitted to such interlocks to provide for emergency operations.
3. That monitoring of continuous running states be automatic, and attention drawn to all incorrect values by audible and visible signals on the display.

4. That a special chart be devised to record unit availability and order of merit.
5. That output records sent to Grid Control be either sent direct by landline automatically, or alternatively prepared in the form of punched tape for computer analysis at Grid Control. Records kept for information at the station be prepared by hand as at present.

Recommendations on Interface Design

1. Control room layout

1.1 The proposed layout is detailed in Fig. 1.

1.2 a) The Charge Engineer's (C.E.) clerk is resited as shown.

b) To enable C.E. to monitor the generator and unit boards during normal running and to allow C.E. to supervise the control actions and decisions made by the assistant during startup and shutdown without leaving his chair.

1.3 a) The Assistant Charge Engineer (A.C.E.) is provided with a desk as shown. The upper section of this desk carries the miscellaneous telephones along the upper edge, and the manual exchange below. The lower section provides a desk space free from drawers, the drawers necessary for storing the various logs and record documents are situated below the telephones.

b) To provide a set station for the A.C.E. and then allow readily, verbal communication between the C.E. and A.C.E.

To provide a station which does not obstruct C.E.'s view of any panel.

To enable A.C.E. to view alarm signal readily.

To allow A.C.E. ready access to the printometer room and the recording panel.

To provide an unobstructed working space for the preparation of the various figures and charts which are necessary and the associated storage. To ensure prompt attention to the various telephones and to facilitate C.E.'s use of these telephones.

To enable A.C.E. to receive and hold any visitors to the control room, if this is made necessary by the crucial actions of the C.E. at a particular time.

1.4 a) The six generator boards, the bus station board and the two station transformer boards are assembled and positioned as illustrated in Fig. 1.

b) To collect together the closely related boards on which direct control is often made and to enable the displays most frequently read, to be most readily available to the C.E.

1.5 a) The six unit boards and the bus section board are assembled and positioned as is illustrated in Fig. 1.

b) To collect together the closely related boards on which direct control of a similar nature is made, together with the display of the overall state of the sub-system as shown on the bus section display. To enable C.E. to easily monitor the unit boards when necessary, at the same time remain facing the console which displays the major states of the whole station.

The siting of these two boards in this manner is intended to provide the C.E. more quickly with an overall picture of the station at any time, but particularly in the event of an emergency and when first coming on shift.

- 1.6 a) The remaining boards, which are largely helpful in exceptional circumstances and do not affect the hour by hour running of the station, nor are directly concerned with the internal situation of the station are grouped and situated as shown in Fig. 1.

A view board consisting of all the recording devices (pen recorders) is formed and is positioned as shown in Fig. 1, beyond 27.

b) The overall dimensions of the Goldington control room have been adhered to, which required one panel to have an inferior site. The boards positioned here, were chosen in order to fulfil the overall requirements of safe and efficient control: it can be seen that they correspond to the least frequently used boards and those least directly used in the hour by hour running of the station.

The four pen recorders at present in use, have no display functions for direct control on the boards on which they are situated. Therefore these historical recording devices are removed to a separate panel, close to the A.C.E. who is responsible for the keeping of these records.

2. Charge Engineers Console (side panels)

2.1 The proposed side panel is detailed in Figure 2.

2.2 a) The demarcation between the sets is clearly made by the use of a separating strip painted along the console, at the head of each of these sub-panels the number of the set it controls is prominently displayed.

b) To reduce the possibility of the wrong set of controls being used, particularly in the initial stages of training.

2.3 a) The test lamp, indicating the functioning of the A.V.R. is removed to position 1. In addition it can be switched on or off by the C.E. from the test panel (14), in the manner of other test devices.

b) To reduce congestion of the controls and the displays related to them. To increase the effectiveness of the test facility: flashing

lights which do not require immediate control tend to distract the attention and eventually their effectiveness is lost, since the controller will come to disregard the signal. Thus, depending on the state of the station, at anytime the C.E. can decide whether to leave the test on, as at present, or cancel the signal.

- 2.4 a) The balancing meter is removed to the position indicated.
- b) This display is little used; namely only on transfer to A.V.R. or vice versa, which may be as little as twice in 24 hours. For this reason it is removed from the controls and displays more frequently used. It is sited off-centre to be directly above the control it is related to. A L → R movement of the field rheostat control will result in a L → R movement of the pointer. The dial of this meter is of the same form as the synchroscope meter, (see fig. 9a, number 3) (at Goldington, glare on the front glass of the dials on the console is a problem, it is recommended that non-glare glass of the etched variety is used for the cover of this dial).
- 2.5 a) The vector meter is sited as shown and the front glass is replaced by non-glare glass of the coated variety.
- b) To overcome glare from the roof lighting non-glare glass is recommended. Vector meters require two indicators and a corresponding increase in distance between the back-plate and the front glass of the meter; for this reason the more expensive coated glass is recommended.
- 2.6 a) The governor control is sited as shown, (4), the form of the control is described fully in diagram 10.
- b) To reduce the risk of faulty operation: or upwards movement of the control increases the load and moves the horizontal vector indicator upwards.
- 2.7 a) The field rheostat is of the type shown and sited as shown.
- b) To remove confusion with the governor the operation is in the other dimension. L → R movement of the control results in a similar movement of the perpendicular vector indicator.
- 2.8 a) A selector switch for auto-transfer-hand is incorporated and the A.V.R. control is removed.
- b) The same control can be used for field rheo and A.V.R. the particular method is elected by 18.
- 2.9 a) The telegraph takes the form illustrated. Press keys are sited directly under indicator lights which bear the instruction to be telegraphed. The key is depressed the indicator light remains on until

the order is accepted by the unit controller. No more than 4 keys are grouped in a consecutive rank.

b) To simplify operation, reduce the chance of a wrong signal going undetected and to reduce the chance of a wrong signal being telegraphed.

2.10 a) All the test facilities are grouped on one test panel. The facilities grouped on this board are: A.V.R. functioning; semaphore lamps (L.H. and R.H.), annunciator lamps (L.H. and R.H.): 132 K.V. trip relay reset; frequency meter functioning.

b) To remove widely scattered, infrequently used controls from important panels. To group all test facilities and to clearly establish a single position in the case of urgent testing of any function. To enable C.E. to carry out a routine check of test facilities.

2.11 a) A microphone on a flexible arm is sited in position 15, replacing the hand set of the telephone to the units.

b) To enable the C.E. to make adjustments to control or logs and at the same time communicate with the unit operation.

2.12 a) The Call-Unit selector is positioned at (16). Illuminated indicators are alive when contact is made with unit; the particular group of 2 units is selected by one of 3 keys. The keys will lock down for prolonged communication, or will function whilst held down. To release a locked key, any other is lightly depressed.

b) To enable C.E. sitting at the console, or the A.C.E. standing in front of the console to manipulate the telephone. To identify the calling unit.

2.13 a) In addition the automatic, internal telephone is positioned on the far right for the right hand side panel.

b) To remove the source of less important messages from information directly concerned with running the station. Thus it was considered that, in general, messages coming via this telephone should not interrupt control action being carried out by C.E. To allow A.C.E. to accept calls if required to do so by the activity of the C.E.

3. Charge engineers console (centre panel)

3.1 The proposed centre panel is detailed in Fig. 3.

3.2 a) The seven quantity displays are all digital type, the digits moving in discrete steps, or clockwise.

- b) To enable accurate readings, (e.g. to 1 M.W. in 180) to be made; to simplify recording into logs. This increased precision may be obtained, since the changes involved in these seven measures are small and the rates of change of the values are of secondary importance.
- 3.3 a) The total production of the station is indicated on (i).
b) To simplify recording and to give the overall output of the station.
- 3.4 a) The demand quantities have red figures on their dials and indicate the instructions from grid control. (The alternative means of communication is via the red telephone (10)).
b) To clearly distinguish between demand and the quantities sent which have black lettering.
- 3.5 a) Frequency sent (7) and demanded (4) is shown on centre console.
b) To remove the need for a main panel to show frequency. To remove the highly unusual circular scale necessary on the conventional frequency meter.
To remove the 5, 'Target Frequency' telegraphs in present use.
- 3.6 a) M.W. sent (8) and demander (5) are shown on centre panel.
b) To allow accurate reading and simple comparison between the two.
- 3.7 a) M.V. sent (9) and demanded (6) are shown on centre panel.
b) To allow accurate reading and simple comparison between the two.
- 3.8 a) A loud speaker from the units is situated on the L.H. side of the console.
b) To enable both engineers to hear the reports of the unit operator and to remove the need for the report to be repeated for the A.C.E. To remove the loud speaker from the microphone and prevent over-loading.
- 3.9 a) The telephone to Grid Control is sited as shown.
b) To enable C.E. to use the telephone and to log the details directly using the right hand.
- 3.10 a) A simple indicator is made to indicate the next set - be it the next set on, or the next set off. It would consist of six removable plates numbered 1 - 6 which would be removed and set in specified order on ring clips according to the instructions of the Charge Engineer.



As each set was put on or taken off, the plate would be flipped down, this indicating the next set.

b) To remove the ambiguity of lists, especially if the C.E. leaves the room and the A.C.E. takes over, during the running up or closing down of the station.

3.11 a) The remaining telegraphs from grid control are grouped in (12). The 4 'REDUCE' signals are grouped in one row.

b) To simplify the layout and to enable the operator to learn and to discriminate the position of the signals reducing the chance of a mis-reading.

3.12 A cancel/accept button is sited as shown. When a new instruction is telegraphed a bell is run continuously to direct the operator to the centre console, (this includes the grid control telephone). A flashing light behind the display in question indicates the change in quantity. Button (13) will cancel the alarm and the indicator light and also signal ACCEPT to Grid Control.

4. Generator Board

4.1 The proposed layout is detailed in Fig. 4.

4.2 a) The number of the generator is prominently displayed at the head of the board, (in a corresponding position to the number on the console and unit boards).

b) To remove as much doubt as possible from the operation of controls which are duplicated and often distant from each other.

4.3 a) A lighted panel (1) is incorporated as an alarm. The recommended alarm procedure is: an intermittent bell sounds to attract the attention of the engineers, this attention is then directed by the flashing of the lighted panel to the particular generator. The particular fault is indicated by a lighted indicator on the panel (4).

b) To provide the fastest detection and identification of a fault indicated by the automatic fault detecting system.

4.4 a) The Indicator warning light panels are incorporated in assembly 4.

b) To group the lights at eye level and to enable dials (5) and (7) to be situated as closely as possible to their respective controls.

4.5 a) The M.W. and M.V. outputs are displayed on 5 and 7 respectively.

b) To associate as closely as possible the output of the generator with respective control lever, thus M.W. is immediately above the governor and M.V. immediately above the rheo.

- 4.6 a) The voltage of the output of the set is displayed on dial 6.
- b) To remove the need for the selecting switch on the control console and the dials on the Bus Section Panel. To enable the voltage to be continually monitored.
- 4.7 a) A circuit breaker (8) is incorporated into the mimic.
- b) To remove the duplication of indicators and the original displacement of control and indicator.
- 4.8 a) The tap control and indicators are removed to the unit board.
- 4.9 a) The governor and rheo are sited as shown and are of the same variety respectively as those controls in the console.
- 4.10 a) The sockets are rearranged as shown.
- b) To correspond to the mimic on the panel.
- 4.11 The sockets and the bars on the mimic are colour coded.

5. The Bus Station Board

- 5.1 The proposed layout is detailed in Fig. 5.
- 5.2 An alarm light is incorporated, 1, to indicate a fault on this panel in conjunction with the audible signal.
- 5.3 Dials 4 and 5, (K.V.; 0-15) on the present design are replaced by individual dials on each generator board as indicated previously.
- 5.4 a) The amps fault locators are sited as shown.
- b) To allow the ampmeter to be located directly above the point on the mimic that the measurement is taken.
- 5.5 a) The fault lights are combined in 12, with the exception that those displayed above the mimic in the present design are now displayed in 6.
- b) To simplify the layout, but maintain the difference between the Station Board faults on 6) and the general faults on 12).
- 5.6 The mimic is redrawn, the circuit breaker/indicator is sited as shown and the surplus indicator scrapped.
- 5.7 The sockets are resited as shown and coated by colour where applicable.

6. The Station Transformer Board

- 6.1 The proposed layout is detailed in Fig. 6.
- 6.2 The standard indicator light carrying the station transformer number is included, 1.
- 6.3 The tap change and indicator arc as described in section 9.
- 6.4 The mimic is altered to allow the tap change to be sited at the R.H. side of the panel.
- 6.5 The circuit breaker and indicator arc combined into control 6.
- 6.6 The sockets are sited as shown and colour coded.

7. The Unit Board

- 7.1 The proposed layout is detailed in fig. 7, all the boards of this form and the idea of using mirror images as in the present design is abandoned.
- 7.2 The changes made are all detailed earlier in the description of other boards.

8. The Bus Section

- 8.1 The proposed layout is detailed in fig. 8.
- 8.2 All the warning lights are combined into one panel (7) and presented at eye height.
- 8.3 The recorder is removed to the recording panel.
- 8.4 The sockets are raised and colour coded.
- 8.5 Other details are described earlier for similar panels.

9. The synchrosopes

- 9.1 The proposed layout of the synchrosopes is detailed in figure 9.
- 9.2 The 'synchroscope on' switch is of the self illuminating key type.
- 9.3 The two voltmeters are combined into a single dial. A red pointer indicates the system p.d. and a black one the generated p.d. When the red position is covered the set is ready for synchronising.

9.4 The single fixed scale mark on the synchrometer is of such a width to include the very small margin of difference from T.D.C. that is allowable.

9.5 The phase angle voltmeter is sited at 3 and the scale selector is of a similar form as the tap control. The actual range is indicated in the window and there is an off position.

10. Controls

10.1 Rheo and Governor controls are as shown in fig. 10a. The knob must be pulled out slightly before it can be moved. The knob is lightly loaded to the centre position. Activation of the control in either direction causes the state to alter in the appropriate direction at a constant rate. This ensures that if the control is momentarily operated, (in spite of the up-out safety feature), little effect will be had on the system.

10.2 a) The pointer will allow a rough estimate of the tap state to be made and the display will give an accurate read off. The display and control are very closely associated.

11 a) The conventional 12 hour clock is replaced by a digital 24 hour clock.

11 b) Much recording of the time, for logging purposes is done and instructions are always associated with times, the times being taken from the 24 hour clock system.

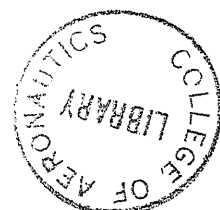

FIG. A.

THE CONTROL FUNCTION

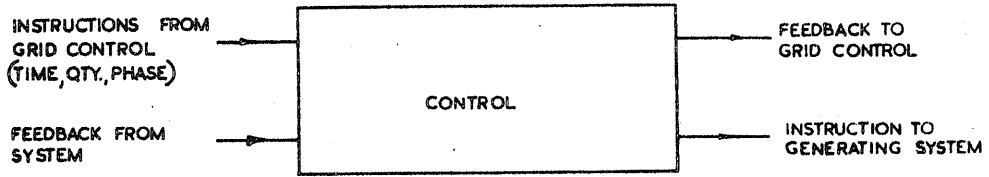

FIG. B.

BLOCK DIAGRAM OF STATION SYSTEM

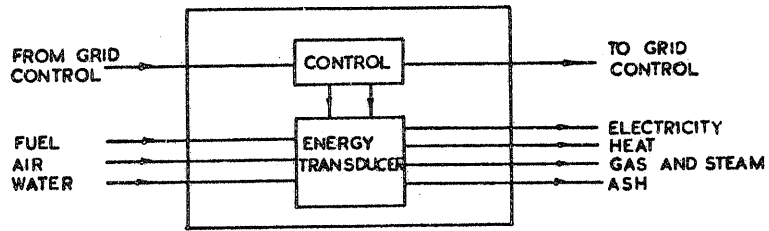

FIG. C. MULTI BLOCK DIAGRAM OF THE ENERGY TRANSDUCER FN.

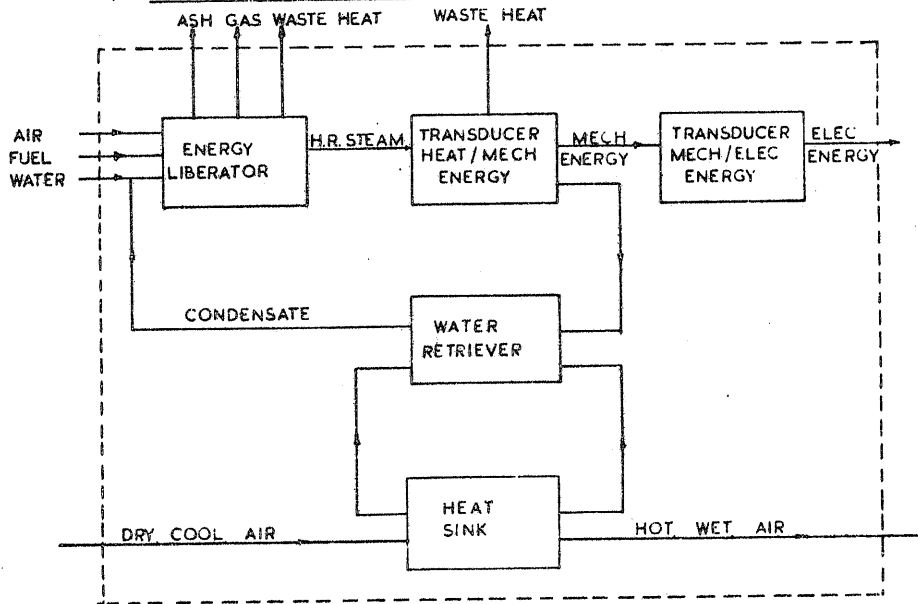

FIG. D

RELATIONSHIP OF SYSTEM & OUTPUT CONTROL

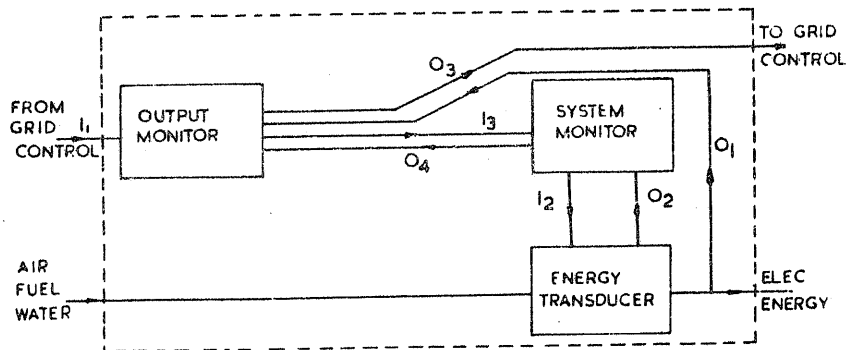
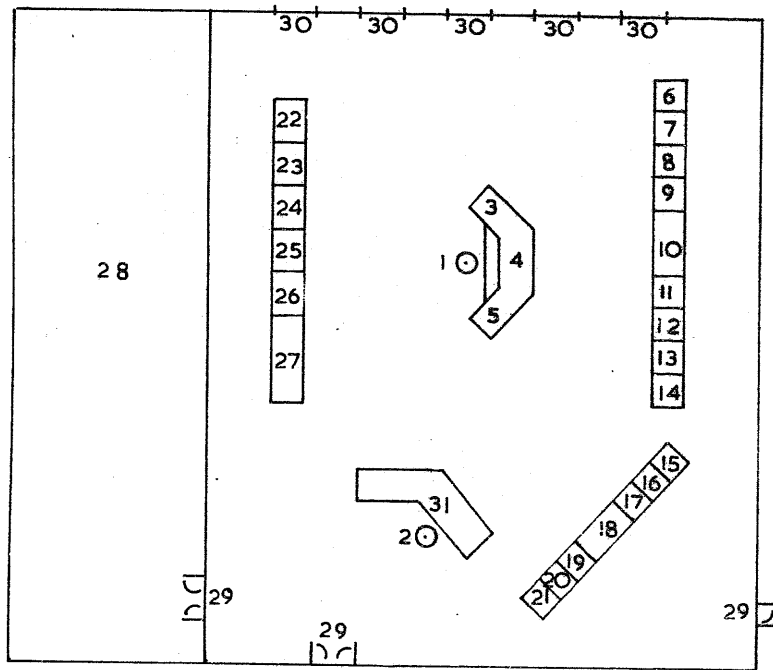

FIG. 1. PROPOSED CONTROL ROOM LAYOUT



LEGEND

- | | |
|--------------------------|---|
| 1 charge engineer | 15 unit board 1 |
| 2 asst. charge engineer | 16 " " 2 |
| 3 console - left panel | 17 " " 3 |
| 4 " central " | 18 bus section |
| 5 " right " | 19 unit board 4 |
| 6 station transformer 1 | 20 " " 5 |
| 7 generator 1 | 21 " " 6 |
| 8 " 2 | 22 bus coupler |
| 9 " 3 | 23 sundon |
| 10 bus station panel | 24 bedford |
| 11 generator 4 | 25 stony stratford |
| 12 " 5 | 26 little barford |
| 13 " 6 | 27 recording |
| 14 station transformer 2 | 28 relay room |
| | 29 door |
| | 30 window |
| | 31 communication & asst. ctl. eng. desk |

FIG. 2. CONSOLE-SIDE PANELS

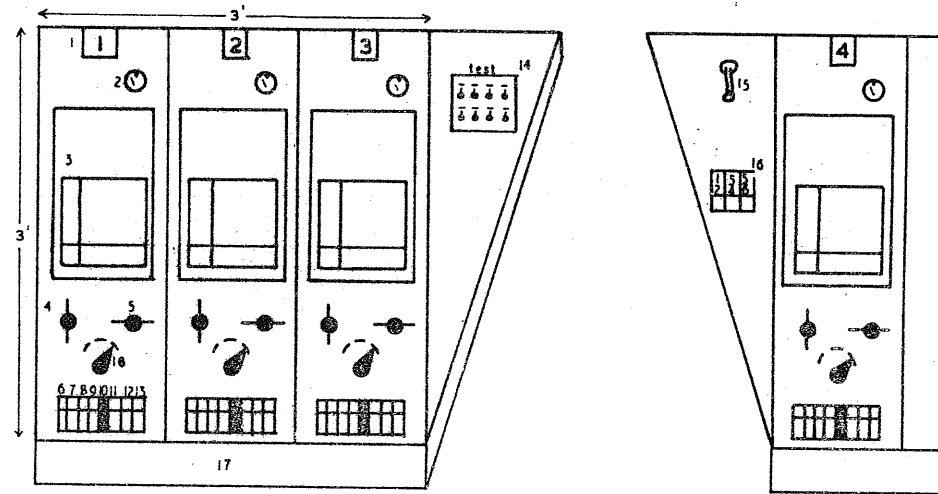

LEGEND

- | | |
|-----------------------|--------------------------------|
| 1 o.v.r. test light | 14 test panel |
| 2 balancing meter | 15 microphone |
| 3 vector meter | 16 call unit selectors |
| 4 governor | 17 drawer |
| 5 field rheostat | 18 auto-transfer-hand selector |
| 6 semaphore to unit | |
| 7 " " " run up | |
| 8 " " " synchronising | |
| 9 " " " on load | |
| 10 " " " shut down | |
| 11 " " " spare signal | |
| 12 " " " load rising | |
| 13 " " " load falling | |
| | |
| | |

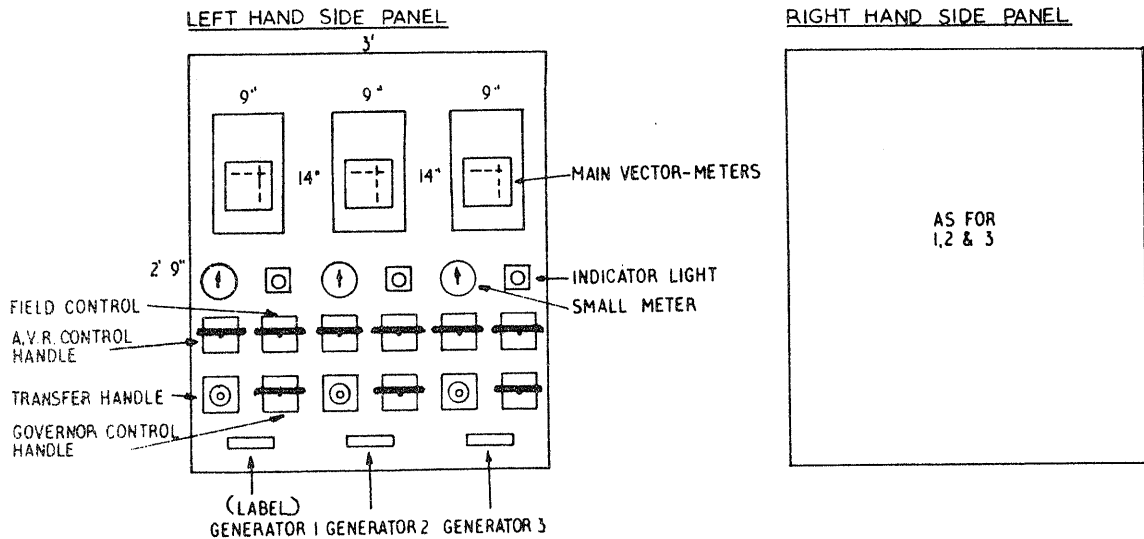

Not drawn to scale

FIGURE 2

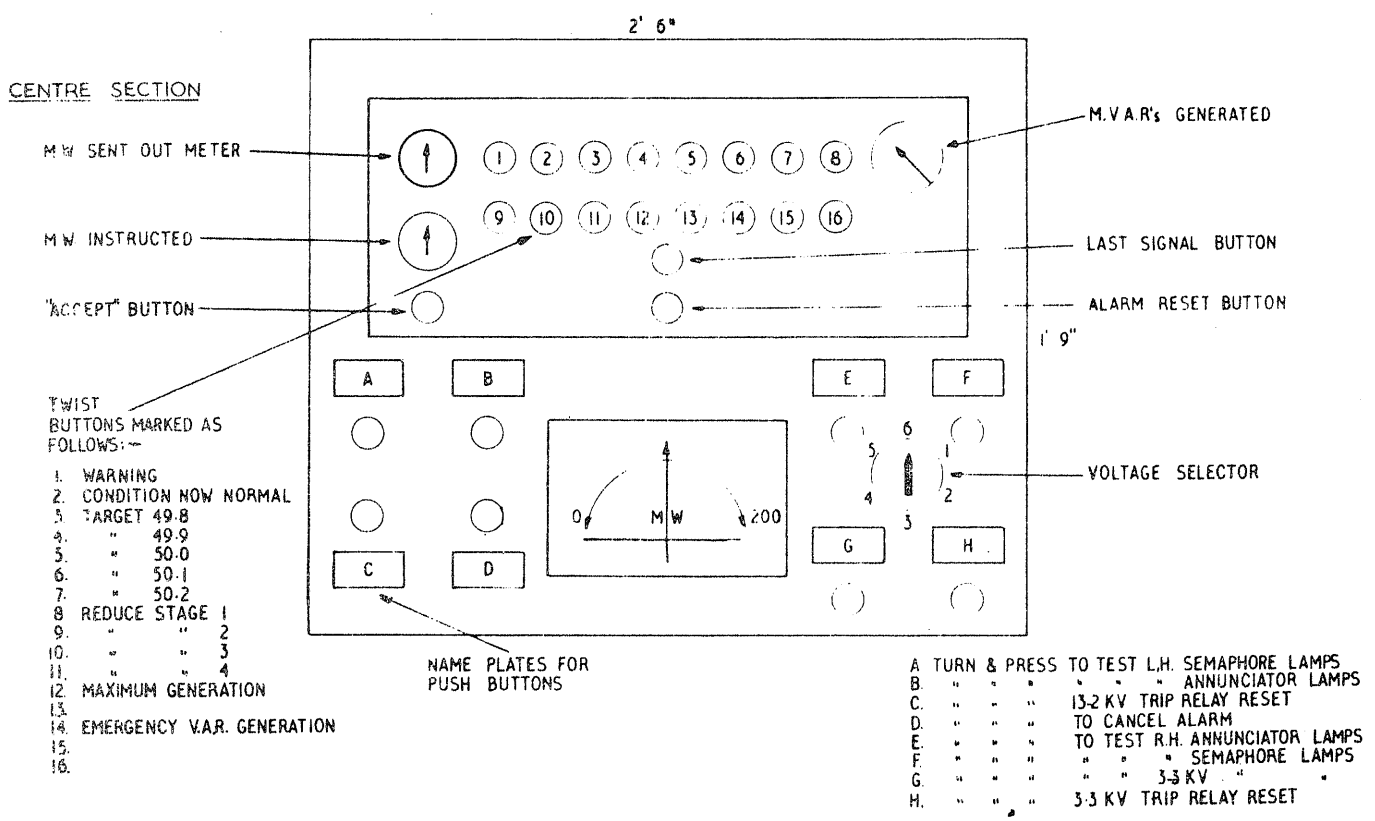

Not drawn to scale

FIGURE 3A

FIG. 3.b CONSOLE - CENTRAL PANEL

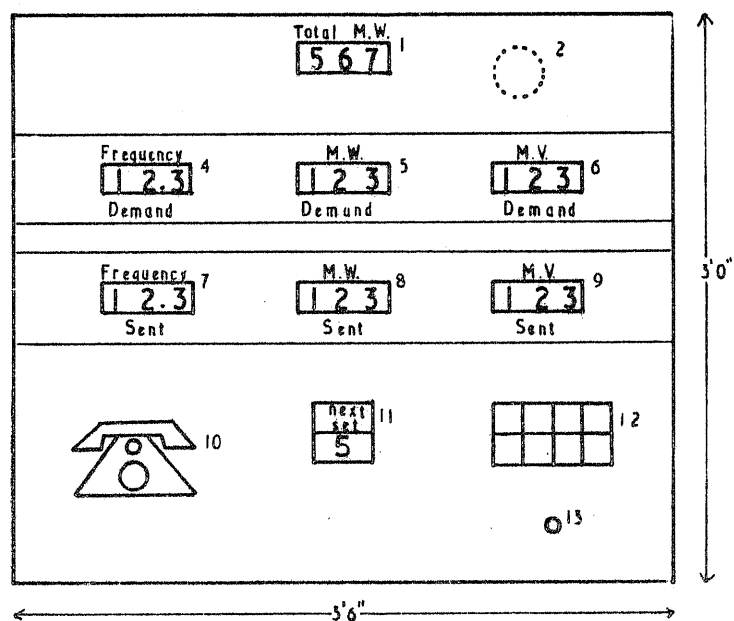

LEGEND

- 1 total output of units
- 2 loudspeaker grill
- 4 demanded frequency
- 5 demanded station output
- 6 demanded m.v.
- 7 frequency sent
- 8 station output sent
- 9 m.v. sent
- 10 telephone to grid control
- 11 next set display
- 12 telegraph indicator
- 13 cancel/accept button

FIG. 4.A.

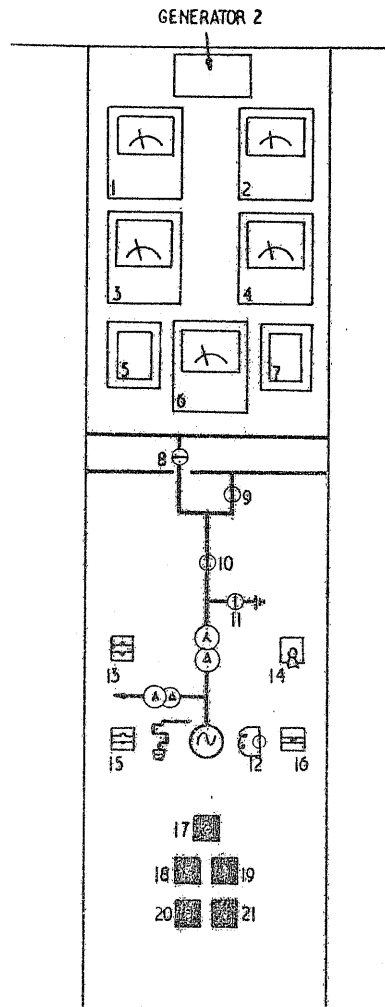

1. AMMETER 0-200 NON LINEAR SCALE
2. EXCITED FIELD AMPERS 0-500
3. MEGAWATTS 0-35
4. MEGAVARS 1 25 NON LINEAR SCALE
5. ALARM WARNING LIGHT PANEL
6. TAP POSITION INDICATOR 1-15 STEPS (UNIT INTERNAL SUPPLY)
7. ALARM WARNING LIGHT PANEL
- 8-12 SWITCH POSITION INDICATORS
13. TAP CHANGE 'T' HANDLE TWIST CLOCKWISE TO INCREASE
14. CIRCUIT BREAKER PISTOL GRIP (LOCKABLE) TWIST CLOCKWISE TO CLOSE
15. GOVERNOR CONTROL 'T' HANDLE CLOCKWISE TO INCREASE
16. FIELD RHEOSTAT 'T' HANDLE
17. METER VOLTAGE PLUG
18. SYNCH. RESERVE BAR PLUG
19. " MAIN "
20. V.T. RESERVE BAR
21. " MAIN "

FIG. 4.b GENERATOR BOARD

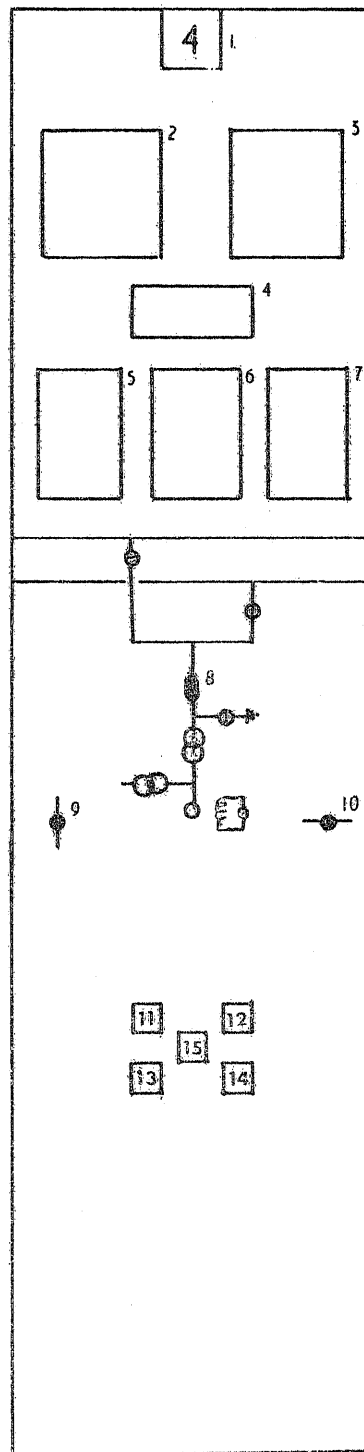

LEGEND

- 1 fault indicator light
- 2 ammeter 0-200
- 3 excited field amps
- 4 alarm warning lights
- 5 megawatts 0-35
- 6 kilovolts 2-4
- 7 megovars ±25
- 8 circuit breaker
- 9 governor
- 10 field rheo
- 11 synch. plug reserve bar
- 12 v.t. reserve bar
- 13 synch. plug main bar
- 14 v.t. main bar
- 15 meter voltage plug

1 foot

FIG. 5.b BUS STATION PANEL

FIG. 5.A.

BUS SECTION PANEL

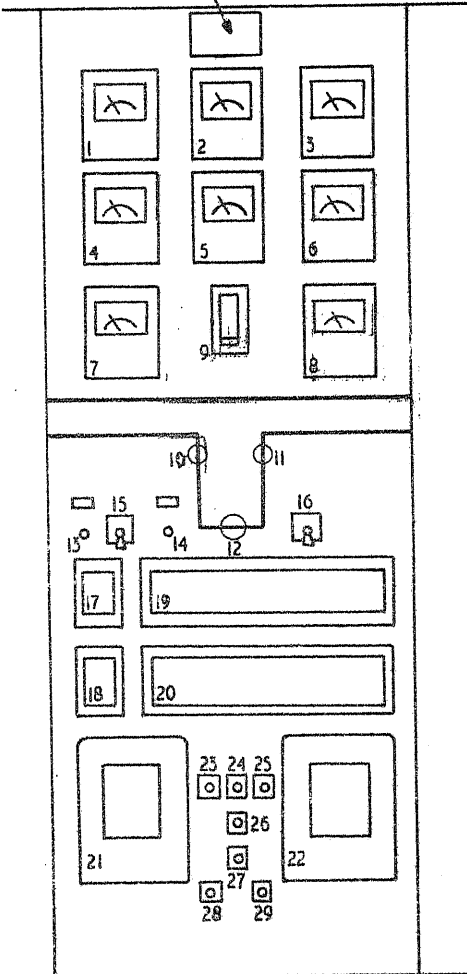

- 1. KV 80-160 MAIN BAR 1
- 2. " " RESERVE "
- 3. " " " "
- 4. KV 0-15 NON LINEAR
- 5. AMPERES 0-600 NON LINEAR
- 6. KV 0-15 NON LINEAR
- 7. AMPERES FAULT LOCATION 0-10/0-5
- 8. " " " "
- 9. LIGHT ALARM
- 10, 11, 12. SWITCH INDICATOR LIGHTS
- 13, 14. VOLT METER ENERGISER
- TURN PRESS TURN TO ACTIVATE
- 15, 16. CIRCUIT BREAKER, PISTO GRIP,
- CLOCKWISE TO CLOSE
- 17, 18. LIGHT ALARMS
- 19, 20. " " " "
- 21, 22. PEN RECORDERS
- 23. VT PLUG TEST RESERVE BAR
- 24, 25. " " MAIN
- 26. METER VOLTAGE PLUG TEST
- 27. SYNCHRONISING
- 28. V.T. MAIN BAR 1
- 29. " " " 2

LEGEND

- 1. fault indicator light
- 2. k.v. main bar 1
- 3. k.v. reserve bar
- 4. k.v. main bar 2
- 5. amp fault location
- 6. alarm lights
- 7. amp fault location
- 8. amps 0-600
- 9. isolator indicator
- 10. circuit breaker
- 11. isolator indicator
- 12. alarm lights
- 13. v.t. test plug: reserve bar
- 14. " " " main bar
- 15. " " " "
- 16. meter voltage test plug
- 17. synchronising plug
- 18. v.t. main bar 1
- 19. " " " 2

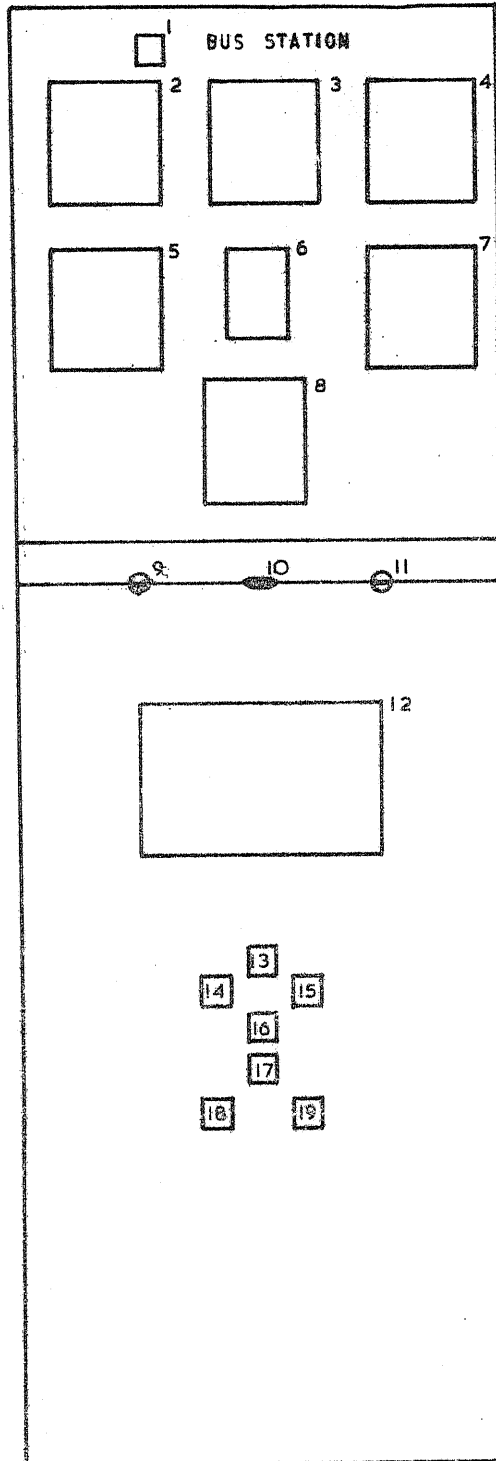

1 FOOT

FIG. 6b. UNIT BOARD

FIG. 6.A

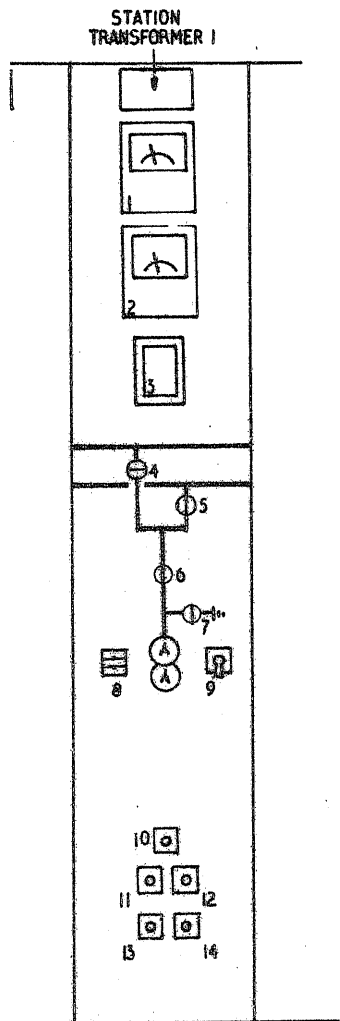

- 1. PRIMARY AMPERS
0-50 NON LINEAR
- 2. TAP POSITION
INDICATOR 1-15
- 3. WARNING LIGHTS
ALARM
- 4,7. SWITCH POSITION
INDICATORS
- 8. TAP CHANGE 'T'
HANDLE TWIST
CLOCKWISE TO TURN
- 9. STATION TRANSFORMER,
CIRCUIT BREAKER,
PISTOL GRIP, CLOCKWISE
TO CLOSE
- 10. METER VOLTAGE PLUG
- 11. SYNCH. RESERVE BAR PLUG
MAIN
- 12. V.T. RESERVE BAR " "
- 13. " MAIN "
- 14. " " "

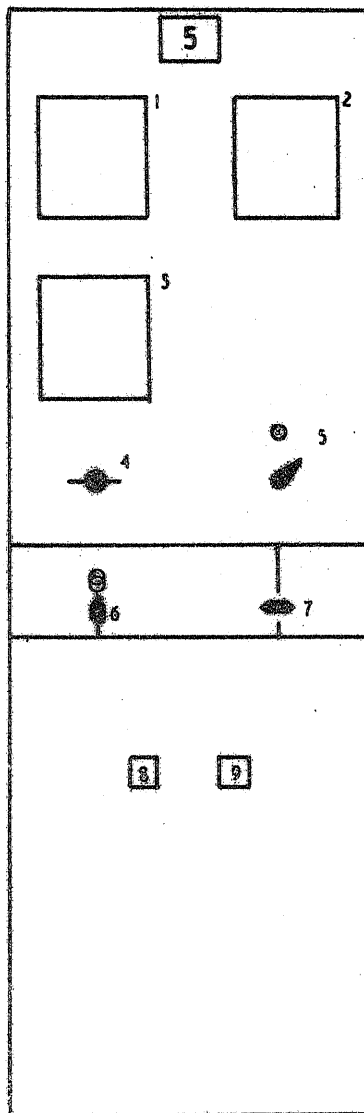

LEGEND

- 1 amps 0-600
- 2 amps 0-600
- 3 k.v. 2-4
- 4 field rheo
- 5 tap control & display
- 6 circuit breaker
- 7 circuit breaker
- 8 synchronising plug
- 9 synchronising plug

FIG. 7.A.

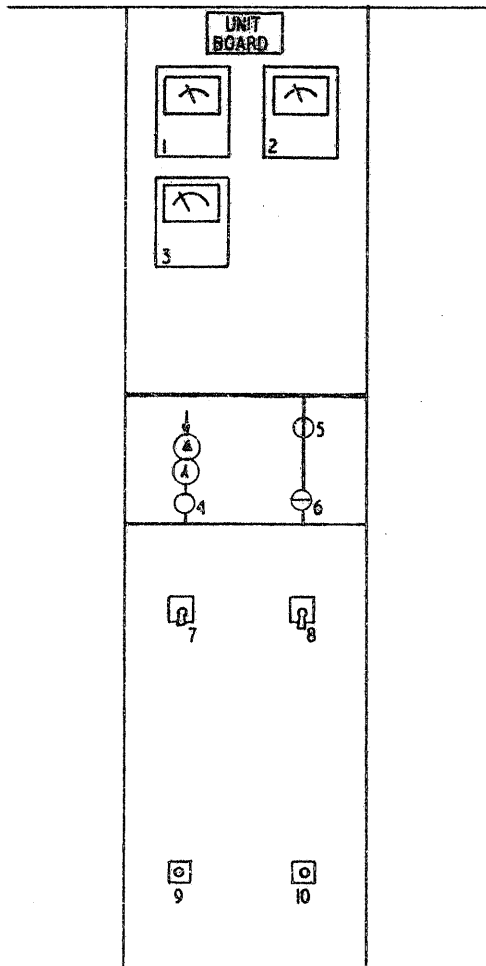

- 1,2. AMMETER 0-600
- 3. KILOVOLTS 2-4
- 4,5,6. SWITCH POSITION INDICATORS
- 7. UNIT TRANSFORMER CIRCUIT BREAKER. PISTOL GRIP, CLOCKWISE TO CLOSE
- 8. STATION BOARD INTERCONNECTOR CLOCKWISE TO CLOSE, PISTOL GRIP
- 9,10. SYNCHRONISING PLUGS

FIG. 7b BUS SECTION PANEL

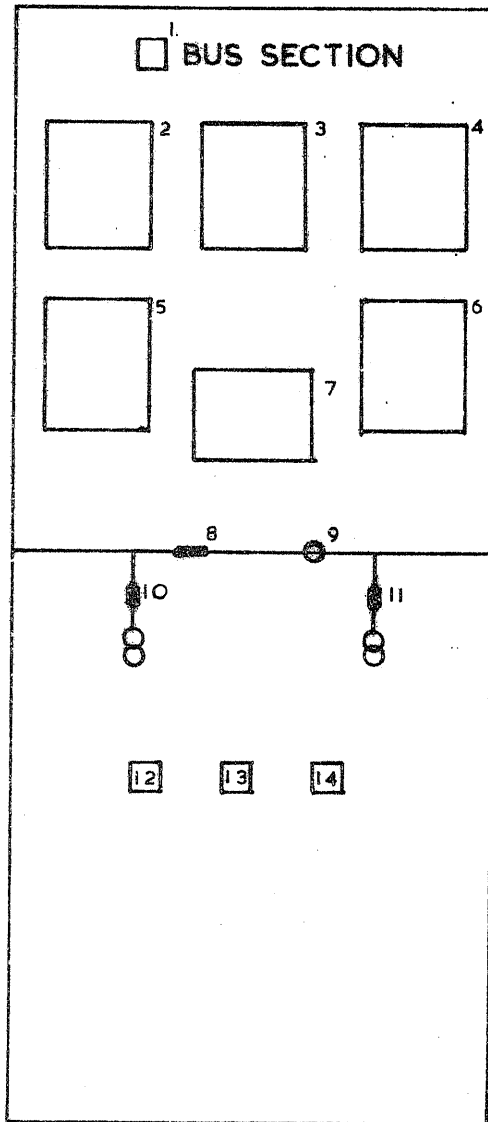

LEGEND

- 1 fault indicator light
- 2 amps 0-600
- 3 " "
- 4 " "
- 5 k.v.
- 6 " "
- 7 alarm lights
- 8 circuit breaker
- 9 isolator indicator
- 10 circuit breaker
- 11 " "
- 12 synchronising plugs
- 13 " "
- 14 " "

FIG. 8.6 STATION TRANSFORMER PANEL

FIG. 8.A.

UNIT CONTROL PANEL

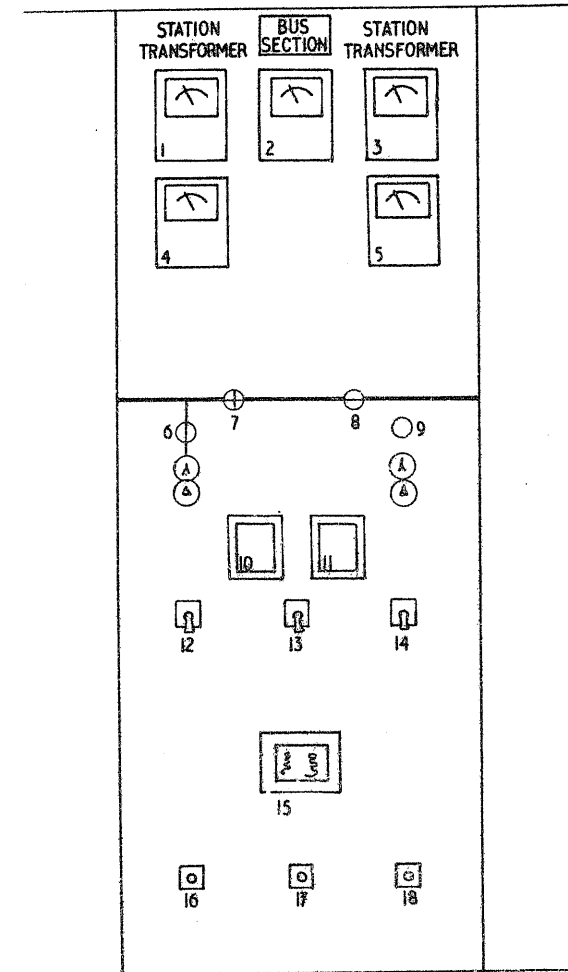

- 1,2,3, AMPERES 0 - 600
- 4,5, KILOVOLTS
- 6,7,8, SWITCH POSITION INDICATORS
- 10 ALARM LIGHTS, TRIP CIRCUIT UNHEALTHY
- 11 ALARM LIGHTS, AUTO TRIP
- 12,13,14 CIRCUIT BREAKERS
- 15. SMOKE DENSITY PEN RECORDERS
- 16,17,18 SYNCHRONISING PLUGS

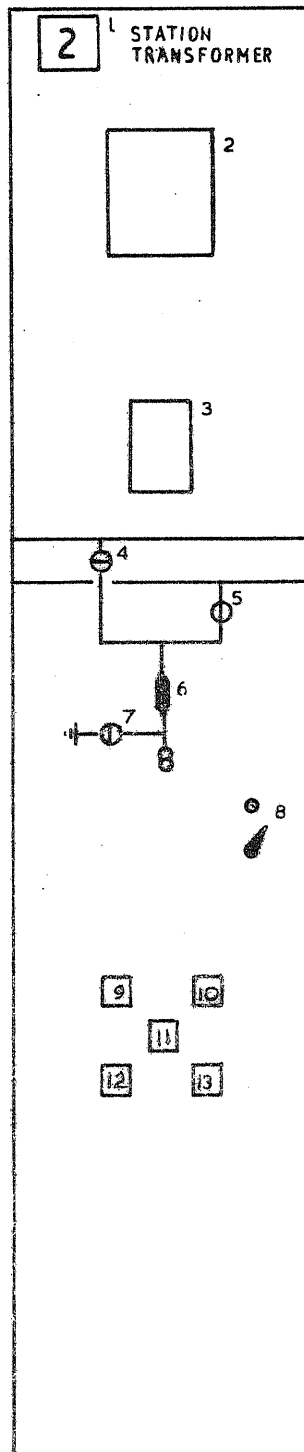

LEGEND

- 1 fault indicator light
- 2 primary amps
- 3 alarm lights
- 4 switch indicator
- 5 " "
- 6 circuit breaker
- 7 switch indicator
- 8 top control & display
- 9 synch. plug reserve bar
- 10 v.t. reserve bar
- 11 meter voltage
- 12 synch. plug main bar
- 13 v.t. main bar

1 foot

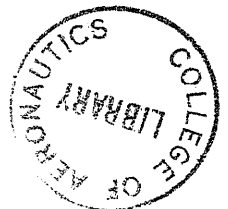
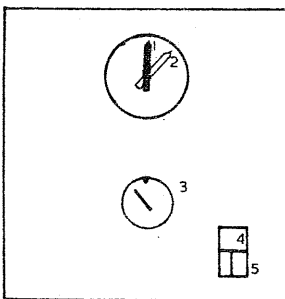

FIG. 9. SYNCHROSCOPS

fig. 9a



LEGEND

- 1 system volts
- 2 set volts
- 3 synchronising meter
- 4 "synch. on" indicator lights
- 5 on/off keys

fig. 9b

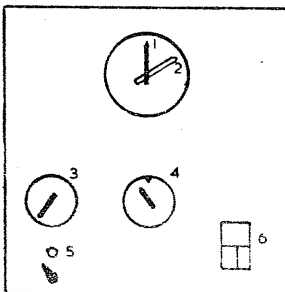

LEGEND

- 1 system volts
- 2 set volts
- 3 phase angle voltmeter
- 4 synchronising meter
- 5 volt range selector
- 6 synch. on/off switch

FIG. 10. CONTROLS

fig 10a governor & field rheostat

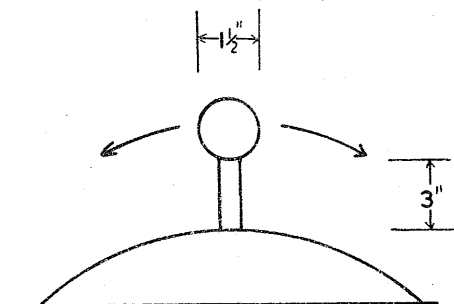

fig 10b tap control & display

