

CRANFIELD UNIVERSITY

CHARLES MACKENZIE ST GEORGE KIRKE

SOCIAL STRUCTURES IN THE REGULAR COMBAT ARMS
UNITS OF THE BRITISH ARMY: A MODEL

DEPARTMENT OF DEFENCE MANAGEMENT & SECURITY
ANALYSIS

SECURITY STUDIES INSTITUTE

PhD THESIS

CRANFIELD UNIVERSITY
DEPARTMENT OF DEFENCE MANAGEMENT & SECURITY
ANALYSIS
SECURITY STUDIES INSTITUTE

Doctor of Philosophy

Academic Year 2002-2003

Charles Mackenzie St George Kirke

Social Structures in the Regular Combat Arms Units of the British Army:
a Model

Supervisors: Professor C. D. Bellamy
 Dr P.R.P. Killworth

December 2002

8 Cranfield University, 2002. All rights reserved. No part of this publication may be reproduced without the written permission of the copyright owner.

ABSTRACT

An original model is presented for describing, analysing, and predicting soldiers' behaviour in current regular combat arms units in the British Army. It was derived, using social anthropological techniques, during participant observation by a serving British Army officer, and provides more coherent insights than other models of unit life. Its central principle, created for this study, is a plurality of '>social structures'. These '>social structures' are separate bodies of ideas, rules and conventions of behaviour which inform groups of people or individuals how to organise and conduct themselves vis-à-vis each other. One '>social structure' operates at any single moment, according to context. Such an approach has not previously been applied to British Soldiers.

The model's top level (low resolution), comprises: the *formal command structure*, consisting in the unit organisation, the apparatus of rank and discipline, and the framework of official accountability; the *informal structure*, comprising the conventions of behaviour in the absence of formal constraints; the *functional structure*, concerning '>soldierly' activity, attitudes, and expectations; and the *loyalty/identity structure*, encompassing the conventions involved in embracing and expressing membership of the formal hierarchy of groups within and above the unit. Lower levels provide higher resolution, including a typology of informal relationships which encompasses different degrees of closeness and differences or equality in rank.

The model's rigour is established by testing its sensitivity at high resolution to the different conditions of life in historical British armies. The top level, however, and the typology of informal relationships, are found potentially to provide a unifying framework for historical analysis of unit life in the British Army throughout its history.

The model's ability to illuminate current issues in the Army is demonstrated by its application to leadership training for officer cadets and the integration of women into regular combat arms units.

ACKNOWLEDGEMENTS

My interest in researching life at regimental duty in the British Army, and the research questions that gave birth to this thesis, have long roots. They go back more than thirty years. Over those years, innumerable people have helped me by listening, by prompting, and by giving advice.

In the period of formal research for this thesis, certain individuals and groups stand out for special thanks, and it seems right to list them here, in no particular order. I am very grateful to Professors Alan Macfarlane and Marilyn Strathern of the Cambridge University Social Anthropology Department, and Professor Christopher Dandeker of King's College London, for putting my feet on useful paths in the early stages. I am equally grateful for the encouragement of Professors Richard Holmes and Hew Strachan as the idea of developing previous work into a full-blown thesis began to dawn upon me, and especially to the latter for publishing my chapter in his book *The British Army, Manpower and Society into the Twenty-First Century*. The interest of, and discussions with, military colleagues, human scientists at the Centre for Human Science (especially Doctors Mike Tainch and Mils Hills), and the virtual population of the 'small-triple-a' discussion group of the 'amateur anthropologists association' [sic] have all been invaluable. And above all, the careful supervision and forthright comments of my supervisors, Doctor Paul Killworth and Professor Christopher Bellamy, have been of major importance.

This research has been heavily dependent on the cooperation and open honesty of all those individuals who have submitted to being interviewed or have given me their experiences on paper, and I am greatly indebted to them. I am also indebted to that countless multitude of British Soldiers through history who left behind them such a wealth of information for studies such as this in their memoirs, letters and diaries.

But, as I said, the roots of this thesis go very deep - much deeper than the formal research period. They go back even before my undergraduate days at Cambridge where the idea of researching this area began to form - and here Professors Myer Fortes and Jack Goody and Doctors Malcolm MacLeod and Peter Silverwood-Cope (the first and last of them sadly now dead) are much to be thanked. The seed was sown on a military exercise in 1971, where six young soldiers of my own age started me wondering about the special intangibles that make one think and feel like a soldier. All junior NCOs, and all totally unaware of the influence they were having, these six are the real point of origin of this thesis. I have no idea where they are now, but to Russell, Howard, Spud, Dave, Barry, and Geordie - thanks lads: you changed the way I think.

CONTENTS

The views expressed in this thesis are the author's own, and do not reflect official opinion or thought.

TITLE PAGE	i
ABSTRACT	ii
ACKNOWLEDGEMENTS	iii
CONTENTS	iv
LIST OF TABLES	vii
LIST OF FIGURES	viii
GLOSSARY/LIST OF ACRONYMS	ix
CHAPTER ONE - INTRODUCTION	1
Background	1
Aim of the Thesis	3
Stages in the Achievement of the Aim	3
'>Modelling' in the Social Science Context	4
Appropriate Strands in Social Theory	8
The Value of the Study	28
Methodology	28
Outline of Chapters	48
CHAPTER TWO - LITERATURE SURVEY	57
Introduction	57

Military Sociology	57
Social Anthropological and Sociological Studies At Unit Level in the Contemporary British Army	61
Historical Studies	63
Similar Studies of British Institutions Outside the Context of the British Army	70
Conclusions	71
CHAPTER THREE - SOCIAL STRUCTURES IN THE COMBAT ARMS: DESCRIPTION OF THE MODEL	76
Introduction	76
The Model - An Overall View	77
<i>The Formal Command Structure</i>	82
<i>The Informal Structure</i>	91
<i>The Loyalty/identity Structure</i>	130
<i>The Functional Structure</i>	139
Interaction and Integration of the Structures	149
Conclusions	155
CHAPTER FOUR - EXPLORING THE MODEL	166
Introduction	166
Application of the Model to the Description of Particular Cases	166
Application of the Model to the Analysis of Particular Cases	171
Application of the Model to Predicting Soldiers' Behaviour	183
Assessment	189
Other Models	199

Conclusion	215
CHAPTER FIVE - TESTING THE MODEL IN THE HISTORICAL DIMENSION	
221	
Introduction	221
Test Question One: Does the Model Reflect the Behaviour of British Soldiers from the Mid Twentieth Century Back to the Mid Seventeenth Century?	228
Test Question Two: Are There Significant Aspects of the Behaviour of British Soldiers of the Past that are not Revealed or Illuminated by the Model?	291
Conclusions	298
CHAPTER SIX - USES OF THE MODEL TO EXAMINE HISTORICAL AND CONTEMPORARY ISSUES	310
Introduction	310
The Past	310
The Present	327
CHAPTER SEVEN - CONCLUSIONS AND IMPLICATIONS	356
BIBLIOGRAPHY	364
APPENDICES	
Appendix A: Reproduction of Kirke, C., 'A Model for the Analysis of Fighting Spirit in the British Army'	387
Appendix B: Text of work in press	388
Appendix C: Sample Interview Questions	406
Appendix D: Background Information on the Structure and Organisation of Combat Arms Units in the British Army	409

Appendix E: Lieutenant Colonel Dalzell's Letter 24 January 1855	417
Appendix F: A Leadership and Management Training Module for Officer Cadets Based on the Model	428
Appendix G: Letters Showing Acceptance of the Model by MOD Institutions	433

LIST OF TABLES

Table 1.1 Hannerz's Conceptual Table of Culture	17
Table 1.2 British Army British Regiments/Corps Personnel - Interviews	34
Table 1.3 British Army Gurkha Personnel - Interviews	35
Table 1.4 United States Air Force Unit - Interviews	35
Table 1.5 Group Interview Sessions	35
Table 4.1 Hannerz's Conceptual Table of Culture	194
Table 4.2 Hannerz's Conceptual Table of Culture (Adjusted)	195

LIST OF FIGURES

Figure 3.1 Social structures in combat arms units	80
Figure 3.2 Informal relationships - outline diagram	92
Figure 3.3 <i>Close Friendship</i>	94
Figure 3.4 <i>Friendship</i>	100
Figure 3.5 <i>Association</i>	103
Figure 3.6 <i>Informal Access</i>	106
Figure 3.7 <i>Nodding acquaintance</i>	107
Figure 3.8 Social Structures in Combat Arms Units - Top Level	155
Figure 3.9 Relationships in the Informal Structure	156

GLOSSARY

ACTIVE EDGE	A short-notice call-out exercise for units in Germany during the Cold War
AWOL	Absent without leave
BC	Battery Commander
BQMS	Battery Quartermaster Sergeant
BSM	Battery sergeant major
Buckshee	A stores item that is surplus to the ledger
Badmash	A bad character (Indian Army)
CO	Commanding Officer of a unit
CSM	Company sergeant major
Don R	Dispatch rider
EO	Enabling Objective (part of the Systems Approach to Training, SAT)
ERE	>Extra regimentally employed', (private soldiers and NCOs only) posted for a tour of duty away from the unit to a post in another establishment
Fatigues	Unpopular labouring tasks for the good of the unit
FGCM	Field General Court Martial
Full screw	Corporal or bombardier (see Appendix D)
Going out on the piss	An evening out drinking
HQ	Headquarters
Lance jack	Lance corporal or lance bombardier (see Appendix D)
LE	Late Entry, the commissioning scheme whereby which senior warrant officers of long service can be commissioned, typically after approximately 20 years service in the ranks

Lt. Ack. Ack.	Light anti-aircraft artillery
M.G. Coy	Machine Gun Company
MMR	Monthly Manning Report
MOD	Ministry of Defence
NAAFI	Naval, Army, and Air Force Institute, providing shops and canteens for Service personnel
NCO	Non-Commissioned Officer, lance corporal/lance bombardier to staff sergeant/colour sergeant (see Appendix D)
Number One	Commander of a piece of artillery equipment (a gun, rocket, or missile system, or meteorological or medium/long range surveillance equipment)
OC	Officer commanding a sub unit
OCTU	Officer cadet training unit
OR	Other Ranks (below sergeant)
PMC	President of the Members' Committee (the officer representing the members of an officers' or Sergeants' and WO's mess)
QM	Quartermaster, a commissioned officer (usually LE (<i>q.v.</i>)) responsible for managing the supplies and services in a unit.
QM(T)	Technical Quartermaster, a commissioned officer (usually LE (<i>q.v.</i>)) responsible for managing the fighting equipment in a unit.
RCT	Royal Corps of Transport (since April 1993 part of the Royal Logistic Corps)
Regimental Duty	Time spent in a unit as a formally posted member of that unit, as opposed to staff appointments or time at ERE (<i>q.v.</i>)
RHQ	Regimental Headquarters, the location of the Commanding Officer's staff and communications

Rifing	Loud scolding
RLC	Royal Logistic Corps
RMAS	Royal Military Academy Sandhurst, where officer cadets are trained to become young officers (not to be confused with Staff or War Colleges, which are military academies in the >academic sense' (e.g. the UK's Defence Academy)
RP	Regimental Police
RSM	Regimental Sergeant Major
RWF	Royal Welch Fusiliers
SAT	Systems Approach to Training
Scale A Parade	An occasion with compulsory attendance
Senior Rank	Senior NCO, i.e. Sergeant, Staff Sergeant, or Colour Sergeant (see Appendix D)
Sprog	Young and inexperienced soldier
Subaltern	Junior commissioned officer, below the rank of captain
TA	Territorial Army
Tom	Private soldier (occasionally includes Junior NCOs (<i>q.v.</i>) as well as privates)
TP	Teaching Point (part of the Systems Approach to Training, SAT)
TQMS	Technical Quartermaster Sergeant, a Warrant Officer (<i>q.v.</i>) who acts as deputy to the QM(T) (<i>q.v.</i>).
Trickle posting	The system of posting soldiers individually between units
TSEOTC	Tri-Service Equal Opportunities Training Centre (Shrivenham)
UN	United Nations
WO	Warrant Officer (see Appendix D), ranked

above a Senior Rank, but below commissioned officer, with overlapping responsibilities with some subalterns' posts, and, depending on post held, important complementary responsibilities with particular officers' posts up to and including the CO

CHAPTER ONE - INTRODUCTION

SECTION ONE - BACKGROUND

An army can be said to have many necessary ingredients - such things as equipment, command and staff structures, fighting doctrine and procedures¹ - but probably the most basic of all are the fighting soldier and the human group in which that soldier fights, 'soldier' in this context (and throughout this thesis) meaning any serving member of a military unit, regardless of rank or position in that unit.

Military groups can be considered special in many ways because of the unique requirement that they should operate effectively under extreme stress, and indeed continue to do so even after suffering sudden and traumatic reduction through casualties and unanticipated member change through the arrival of reinforcements and battle casualty replacements. It is this unique and special nature of military groups and the social bonds that define and sustain them that led to the choice of subject area for this PhD study: social structures in the regular combat arms units of the British Army.

The term 'combat arms' is used throughout this thesis to cover the regular units of the Household Cavalry and the Royal Armoured Corps, the Royal Artillery, the Royal Engineers, the Infantry, the Royal Signals and the Army Air Corps. These are the elements of the Army that can be expected to be deployed in war as formed units whose prime role lies in the forward battle area. Whilst in reality soldiers from the supporting services (the Royal Electrical and Mechanical Engineers, the Royal Logistic Corps, the Intelligence Corps, the Adjutant General's Corps, the Royal Pioneer Corps, the Royal Army Medical Corps and the Royal Army Chaplain's Department) may confidently expect to spend part of their time in the forward battle area, the significant distinction between them and what I have called the 'combat arms' lies in the fact that they would not deploy there as part of formed units of their own corps.

The Territorial Army ('the TA') contains a number of units that fit the description of 'combat arms'. However, TA units have been excluded from this study because of the

significant time that their members spend outside the context of their units, and indeed outside the milieu of the British Army, as they pursue parallel lives as civilians fully embedded in the wider British society. Regular soldiers present an analytically tighter case.

Another important group that was not included in this study is Special Forces. Their exclusion was a pragmatic measure as access to Special Forces units is difficult, and any conclusion that might have been drawn from research among them might have been subject to problematic security considerations. The small number of individuals with a Special Forces background that were included in the study were all serving at the time in conventional military units.

Although the starting point of this study was interest in the various groupings observed within combat units, the resulting research has a wider scope than the examination only of groups. To draw an analogy from the everyday industrialized world, it is possible to liken the research area to the metro or underground transport system in a large town: at street level, the only visible manifestations of the system are the station entrances and the occasional glimpses of the railway, but there are large and complex systems (systems of control, of ventilation, of maintenance, of passenger management, and so on), which are hidden from view below ground. In the same way, the observed behaviour of soldiers, individually and in military groups, is only the obvious and external manifestation ('the stations') of a complex and interwoven web of ideas, rules and conventions of behaviour (the 'hidden systems'). This research seeks to reach beyond the obvious - military groups and the observed behaviour of soldiers - into the hidden area, comprising the web of conventions, attitudes, and expectations that underlie the everyday life of British soldiers in combat units.

The academic discipline in which the research has been centred is Social Anthropology, a social science conventionally directed towards the study of small scale human groups of a few hundred individuals² rather than the larger societies that are generally the province of Sociology³. It is highly suitable for a study of this kind because military units comprise groups of exactly the sort of scale that it was developed to deal with. It is a many-stranded discipline, and the selection of the appropriate strands for this study is dealt with below.

However, the roots of this thesis go into other disciplines as well. These include those strands of Sociology that inform our views of the concept of social structure and give insights into military social systems, Modelling insofar as it is related to social systems, and those aspects of History that address the British Army.

This study has its importance in the insight that it can potentially give into the lives of a distinct and identifiable element in British Society, a body that attracts a considerable amount of public attention and support⁴ and interest in the media and at Government level, but one that is sparsely researched and appears somewhat arcane to outsiders⁵. Furthermore, it is an element of British society which is becoming less and less well known as the number of people with experience of membership of the Army declines following the ending of National Service in the early 1960s and the further reductions in the numerical strength of the Army which have continued after that.

SECTION TWO - AIM OF THE THESIS

The aim of this thesis is to present a model generated using social anthropological techniques, which can be used with a degree of confidence to describe, analyse and predict the behaviour of British soldiers in regular combat arms units in the current British Army.

SECTION THREE - STAGES IN THE ACHIEVEMENT OF THE AIM

This thesis will achieve this purpose in the following steps:

- Presentation of the model⁶, and demonstration of its utility as a tool for examining the behaviour of contemporary British soldiers in their units⁷.
- Explanation of how the model has been tested by exploring its limits. This was achieved by applying it to the examination of British soldiers' first hand accounts in selected periods over the past 300 years, exploiting Bellamy's principle that history is the 'database'⁸, to see whether it fits their behaviour and attitudes and whether it

yields any insight into their lives. Material was chosen from the mid seventeenth century, mid eighteenth century, late eighteenth and early nineteenth centuries, the mid nineteenth century, and the early and the mid twentieth century.

- Exploration of options for further implementation of the model to address historical and contemporary issues in the British Army.

SECTION FOUR - 'MODELLING' IN THE SOCIAL SCIENCE CONTEXT

It will be clear from the preceding passage that a central element in the study is the concept of a 'model'. The use of this term, however, in the words of Giddens and Turner, 'is highly ambiguous in the social sciences'⁹ so the purpose of this short section is to remove the ambiguity in this context.

'Model' can be used to cover a spectrum of possible meanings, from a simple analogy such as the structure of a metro system used on page 2 above, to complex mathematical devices such as the Janus wargame used for training and operational analysis in land warfare¹⁰. Interim positions along this spectrum are illustrated in these three quotations:

- For Giddens and Turner the term means 'theorizing in which concepts and their relations are presented as a visual picture that maps properties of the social universe and their interrelations'.¹¹
- For Loomba a model is 'a particular representation of a system, which, in turn, represents specified aspects of reality', and the purpose of a model is 'to *describe*, *explain*, and *predict* the behavior of a system'. He adds that 'If a model proves to be a reliable predictor of system behavior, it can also be used to *prescribe* preferred courses of action'¹².
- Chapman says that 'models are *heuristic* devices - essential aids in the process of analysis. The fact that subsequent researchers prove them to be faulty doesn't [*sic*]

matter. What is important is that they provide us with first approximations which we can test and out of which we can build theories which have more powerful explanatory value.’¹³

In the absence of an externally valid definition, a social ‘model’ will be taken here to mean any epistemological device that can be used to describe, analyse, and predict the behaviour of human beings, or to explain it in retrospect. In the context of this study, therefore, a model must demonstrably be capable of carrying out all these three functions.

An important consideration is the language in which a model is to be expressed. Wilson describes the range of options as another spectrum,

‘This spectrum extends from the well defined (hard) problems, in which the modelling language may be mathematically oriented, to soft, ill structured problems in which a modelling language is required which is capable of a richer description of the real world than mathematics can provide.’¹⁴

Because the sort of human interaction with which this thesis is concerned falls towards the ‘ill structured’ end of the range of modelling problems, a textual rather than mathematical presentation will be required. The choice of language in the model is therefore no trivial matter, and is a profound element in its shape and utility.

Another fundamental element in modelling is the need for the limits of any particular model to be explored by some form of testing before it can be accepted as useful. As Withey has succinctly stated in the field of human physiological modelling,

‘As with all analytical modelling techniques, the validity of the model is crucially dependent on the underlying assumptions and on the extent to which validation is possible.’¹⁵

It is necessary, therefore, to test the model at the heart of this thesis to ensure that it has a degree of rigour and to explore the limits inherent in its assumptions and simplifications. If it cannot be shown to have any limits at all then it is vulnerable to the criticism that by apparently explaining everything it might indeed be explaining nothing, or if its assumptions and simplifications are found significantly to distort the data then its usefulness would be limited.

However, if once it has been tested it is found to give convincing and useful insights, it may then be considered to be a suitable tool to exploit those insights, both in examining situations to which it is relevant and in prescribing preferred courses of action.

Finally, before we turn specifically to the uses of models in social science, it is as well to bear in mind in constructing, testing, and using a model that, in the words of Wilson, whose considerable expertise is in soft systems modelling, 'Models (of any kind) are *not* descriptions of the real world [;]¹⁶ they *are* descriptions of ways of thinking about the real world'¹⁷.

There is a long history of the use of models in social science, though few if any models survive unchanged to have any permanence in the literature. One particular example was prevalent for many years, seeming almost to achieve the status of a permanent background assumption, but even this one fell out of favour in the end. This was the biological model or the organic metaphor, which likened a society to an organism with an internal structure and a set of processes that were all in balance - the concept of 'homeostasis' in biology. Coined in the late nineteenth century¹⁸, it remained current until the 1960s, when it began to suffer challenge by such critics as Leach:

'But as soon as we ask such questions as[,] Is society really an 'organism'? Where do we discern the boundary between one society and the next? How do we distinguish between a society that is in good health and one that is in a pathological condition?, the extreme artificiality of the model becomes apparent.'¹⁹

and it still had some currency in the 1980s, because Giddens felt it necessary to make a point of reacting strongly against it, calling it a 'noxious presumption'. He continues,

'There are few today who, as Durkheim, Spencer and many others in nineteenth-century thought were prone to do, use direct organic analogies in describing social systems. But implicit parallels remain very common, even among those, for instance, who talk of societies as 'open systems'. A second factor is the prevalence of what I call 'endogenous' or 'unfolding models' in the social sciences. Such models presume that the main structural features of a society, governing both stability and change, are internal to that society. It is fairly evident why this is frequently connected to the first type of view: societies are imagined to have properties analogous to those which control the form and development of an organism.'²⁰

Giddens is not, however, against the use of models *per se*: only inappropriate ones. Indeed, his concept of ‘Structuration’²¹, introduced below (see page 13 below), is itself an important model in the field of social science.

The use of models in Social Anthropology in particular was considered to be an important enough subject to be chosen as one of the three most immediate topics for consideration by the then newly formed Association of Social Anthropologists of the Commonwealth (the ASA) in 1965, as Gluckman and Eggan make clear in their Introduction to the series of ASA Monographs²². Four significant points that emerged from this important work on social anthropological models are of relevance to this thesis.

First, Goodenough shows that appropriately constructed social models can be used to investigate intangible aspects that are hard to get at any other way, providing

‘Methods that allow us objectively to measure such things as anger, insult, flattery, and the gravity of offenses [*sic*], and that help us to appreciate the poetic justice of events in alien cultural contexts, such methods, I submit, are not exercises in sterile formalism. They promise to be powerful analytical tools. They encourage me to great optimism about the possibility of developing considerable precision in the science of social behavior.’²³

Secondly, Schneider produces a well timed warning against constructing a model and then treating it as if it tells the whole truth about the social system or subsystem that it is supposed to be portraying. For example,

‘There has been a tendency to erect a typology and to defend it to the death against all comers; even against the facts where these prove stubborn.’²⁴
and

‘Let me be very clear on this problem. The model which is a total-system model, which yields a typology, and where there is no specific aim or purpose for which that typology is constructed is, I think, demonstrably a mistake. Too much time, effort, and energy are spent in mending the model, in protecting it from new data, in insuring [*sic*] its survival against attacks.’²⁵

Thirdly, in examining the conventional anthropological ideas of ‘patrilineal’ and ‘matrilineal’ descent Lewis points out that there is a danger that anthropologists can be guilty of forcing their data to fit a particular model, and thus to make unwarranted assumptions. In particular, he shows that anthropologists had frequently taken the ‘Roman *gens* organization

and *patria potestas* as the paradigm [or definitive model] of patrilineal descent²⁶ whereas it was in fact only one manifestation of a wide variety of possible arrangements for the passing down of property through the male line.

Finally, Ward shows that different, and perhaps contradictory, models can exist simultaneously in the minds of the same people, and these models can be fundamental in their culture, even to the extent that they concern the governing principles of their own society,

‘The people of Kau Sau appear to have three different kinds of model of Chinese social arrangements in their consciousness. First there is their own notion of their own social and cultural system; this ... we called the ‘home-made’ model; Second, there is their version of what they believe to have been the traditional literati system; this we named the ‘believed-in traditional model’ Then, third, there are the various models they have constructed of the socio-cultural arrangements of other Chinese groups. These we called ‘internal observers’ models’. As a type they differ from observers’ models proper (i.e. the models constructed by outsiders, including social scientists) only in that they are held by people who consider themselves members of the same wider society with [*sic*] those whom they are observing.²⁷

These important papers therefore provide a set of encouragements and warnings to anyone seeking to use a model in social science: encouragement that models can reveal the intangible, but warnings against treating a model as fact and forcing data to fit it, against making unwarranted assumptions that bias the structure of the models to be used, and against thinking that there can be only one definitive model in any social study.

SECTION FIVE - APPROPRIATE STRANDS IN SOCIAL THEORY

This section sets out what is perforce a brief review of the strands in social theory that are applicable to this thesis. The main emphasis is on Social Anthropology, as that is the central discipline from which this thesis has been constructed, but we will also visit particular areas of Sociology.

The concept of ‘culture’

Because it is a central feature of social science in general, and Social Anthropology in particular, it is important to have a working definition of the term ‘culture’. The term is used here, as is normal in social science, to refer to knowledge that is not acquired or passed on genetically: behaviour, attitudes, and thought processes that are consciously or unconsciously learned rather than innate²⁸. Hence, each social group has its own body of culture, and, of particular relevance to this thesis, organisations have ‘organisational culture’²⁹. The model which this thesis presents, therefore, could accurately be described as a representation of the organisational culture of the British Army, at least as far as the regular combat arms units are concerned.

The development of Social Anthropology

Social Anthropology has its origins in late nineteenth century Sociology and has been developed in a number of different ‘schools’ to its current position³⁰. It departed from Sociology early in its development by preoccupying itself with groups of what were then called ‘primitive’ people, as distinct from Sociology’s preoccupation with industrialised societies³¹. Thus, for example, Radcliffe-Brown (1881-1955), one of the leading personalities of the so-called ‘British School’ of Social Anthropology considered the discipline to be ‘the comparative sociology’ of ‘primitive or backward peoples’³².

Like all academic disciplines, Social Anthropology as it is today is a child of its history. Useful summaries of the various stages in the development of social anthropological theory up to the early 1960s are given by Mair³³ and Beattie³⁴ in their seminal introductions to the discipline. Grimshaw and Hart³⁵ provide a more recent (1993) complementary if politically informed review which is a useful counterbalance to the essentially colonially based establishment stance of Mair and Beattie. The common threads in virtually all descriptions of Social Anthropology are that it is concerned with the study of small groups (a few hundred or less), that extended participant observation (‘fieldwork’) is a vital ingredient, that anthropologists attempt to study a society holistically (in contrast to the sociologist’s frequent

preoccupation with social themes), and that there is an underlying desire for comparative studies between different societies. The British School tended to concentrate on social structure and the bonding functions of social institutions, brought together under the name 'Structural-Functionalism'³⁶.

From the 1960s, the discipline began to become fragmented. As Asad put it in 1979,

'For a long time now anthropology has ceased to constitute a coherent field of intellectual enquiry and its present unity is institutional and not theoretical. My comments relate therefore to particular strands within social anthropology which seem to me to hang together in significant ways, forming a recognisable pattern that has become an obstacle to further development, and one which it would be worth examining more closely. I repeat, this pattern does not define the unity of anthropology because it relates to a number of assumptions and tendencies that are neither exclusive to it, nor for that matter shared by all texts which would be called anthropological.'³⁷

and Grimshaw and Hart,

'For a time during the 1960s and early 1970s, when the world was shaken by popular movements, British anthropologists flirted with stronger notions of universality, involving the human mind and world history; but of late they have returned to a narrow particularism, embodied in subdisciplines whose sole aim is to colonise a fresh segment of human experience, often one carved out by neighbouring professions (medicine, development, literature).'³⁸

Ortner provides an account of the state of the discipline in the mid-1980s³⁹ in a valuable paper which summarises the main theoretical schools, insofar as they can be teased out of the flux and mixture of ideas that were current at the time. For all practical purposes her paper describes the current situation reasonably well, except that there has been an increasing emphasis, as elsewhere in the social sciences, on postmodernist ideas that call into question the existence of any form of disinterested or neutral social science research. Postmodernism will be considered later in this chapter.

It is clear from all these accounts that, because Social Anthropology has evolved in several different strands, there is no single current authoritative definition of the discipline, nor one single authoritative custodian institution of social anthropological standards. Rather, there is a common interest between various schools and mutually recognisable subdisciplines within

Social Anthropology, and this common interest is centred upon the lives of human beings in small groups.

It is also clear that, because there is no central methodological authority for Social Anthropology, the discipline has been, and will continue to be, blessed (and occasionally cursed) by varied sets of approaches and resources for tackling similar problems and issues.

The concepts of ‘social structure’ and ‘agency’

The concept of social structure is fundamental to this thesis, as the title makes clear. This concept consists in what was a long standing assumption that treats a society in Mair’s words from the 1960s as,

‘an orderly arrangement of parts, and [the social anthropologist’s] business is to detect and explain this order. It consists in relationships between persons which are regulated by a common body of recognized rights and obligations.’⁴⁰

This structure is in essence a framework of rules for everyday life to which all integrated members of the society or human group in question subscribe. It is expressed in the regularities of the day to day activity of those people where, as Gluckman and Eggan have put it,

‘the events which comprise human behaviour exhibit regularities whose forms are mutually interdependent, over and above their interdependence in the personality-behaviour systems of each individual actor.’⁴¹

An important part of the idea of social structure is that it is at least partially invisible to the individuals in the group. Emile Durkheim (1858-1917), one of the nineteenth century giants of Sociology, explained this idea with an analogy,

‘The hardness of bronze lies neither in the copper, nor the tin, nor the lead which have been used to form it, which are all soft and malleable bodies. The hardness arises from the mixing of them. The liquidity of water, its sustaining and other properties, are not in the two gases of which it is composed, but in the complex substance which they form by coming together. Let us apply this principle to sociology. If, as is granted to us, this synthesis sui generis, which constitutes every society, gives rise to new

phenomena, different from those which occur in consciousness in isolation, one is forced to admit that these specific facts reside in the society itself that produces them and not in its parts - namely its members. In this sense therefore they lie outside the consciousness of individuals as such, in the same way as the distinctive features of life lie outside the chemical substances that make up a living organism.’⁴²

This idea of an unconscious ordered regularity of rules of everyday life has persisted as an undercurrent in social science up to the present day, mainly because it seems to reflect the observed facts. People do behave as if they are subscribing to a common set of rules of conduct, there are ordered regularities in everyday life, and few (except social scientists) see any need to articulate or codify them.

However, the concept of ‘social structure’ has come under attack as new strands of social theory have emerged. First, it is now accepted that ‘society’ and ‘structure’ can no longer be considered as empirical realities, as Durkheim and his followers appeared to consider them. Rather they are best treated as models that are useful in explaining social phenomena. Second, it has been considered that these models give too little room for considering the freedom of individuals to choose courses of action in the practical business of every day life⁴³. Such individuals’ attitudes and expectations appear in the model of ‘social structure’ as secondary to, and formed by, the rules and conventions in their particular society. In contrast, as we shall see below, regularities of everyday life only exist through the actions of the individual agents: if people stopped practising them then they would cease.

Thirdly, it is now considered that the idea of social structure is essentially static, and so it is not helpful in explaining change in a society. As Asad has stated,

‘One aspect of this weakness can be seen in what is often admitted to be the repeated failure of social anthropologists to produce a viable theory of social change. The reason for this may not be, as it is sometimes proposed, that ‘real’ factors of social change are many and complex, which is a practical difficulty, but rather that the way the object of change is itself conceptualised makes the possibility of such a theory difficult if not impossible.’⁴⁴

All this has shifted the emphasis from ‘society’ to the place of the individual - the ‘agent’ - in his or her society.

The particular body of thought that deals most prominently with the individual in society has been called 'Practice Theory', or less commonly 'Process Theory'. It highlights the difference between 'rules' (in either the formal legal sense or the unwritten social sense) and the 'action' of individuals. As Ortner put it,

'...modern practice theory seeks to explain the relationship(s) that obtain between human action, on the one hand, and some global entity which we may call "the system," [i.e. the 'rules'] on the other. Questions concerning these relationships may go in either direction - the impact of the system on practice, and the impact of practice on the system.'⁴⁵

Although it is not a single school of thought, in the sense of having a unified body of intellectual leaders and devotees, its adherents comprise a number of theorists who consider the actions of the individual in a social system. Practice theory takes as its starting point the fact that the elements of social structure can only persist through time if they are reproduced by what individuals do, a process called 'structuration' by Giddens⁴⁶. Elements of social structures can and do change with the passing of time, and they can only do so because there is some form of collective action on the part of the individuals.

A trivial example from the dress of Cambridge undergraduates will illustrate the idea. As Meyer Fortes, the Professor of Social Anthropology, was fond of pointing out, in the mid-1960s the wearing of a tie at student lectures was almost universal but by 1971 it was exceptional⁴⁷. Nobody had issued a formal instruction to undergraduates that the practice should change, nobody had conducted an 'anti-tie campaign', no student meeting had taken it as an agenda item, yet change had come through a series of individual and unconnected decisions by the agents (the students) through time.

Similarly, in his 1990 book *Being Unemployed in Northern Ireland* Howe⁴⁸ used the ideas of Practice Theory to show how the individual members of the Department of Health and Social Security created their own modifications of the regulations governing welfare payments. In spite of the legal principle that benefit payments should be made on a universal and disinterested basis, the civil servants involved had developed their own unwritten and barely articulated code dividing the applicants into 'deserving' and 'undeserving' categories, and they were treating the 'deserving' cases preferentially. Interestingly, the

reason for this informal modification of an apparently binding administrative system was the simple constraint that they did not have enough resources (time and/or personnel) to observe the formal rules, but were driven to modify them for practical reasons. Their practice represented a resolution of the tension between rules and constraints.

An important contributor to the body of theory on 'practice' is Pierre Bourdieu (1930-2002). In his Introduction to the English translation (1991) of one of Bourdieu's key works, 'Language and Symbolic Power', Thompson sums up Bourdieu's contribution as follows:

'He portrays everyday linguistic exchanges as situated encounters between agents endowed with socially structured resources and competencies, in such a way that every linguistic interaction, however personal and insignificant it may seem, bears the traces of the social structure that it both expresses and helps to reproduce.'⁴⁹

This passage is specifically about linguistic exchanges, but it encompasses one of Bourdieu's most important general points. This is that each individual - each agent - goes through a large number of experiences in his or her life and that these experiences are socially structured in that they are founded on, and generated by, what is considered 'normal' in the society in question. These experiences in turn shape his or her assumptions and expectations and thus inform his or her actions and interaction with other people. Those actions and interactions express and re-create the social influences that gave birth to them, and generate further practices and perceptions in the individual and the social group. Social structure is thus experienced, expressed, and re-created in a continuous cycle during the processes of normal life.

Bourdieu's two key ideas in the context of this thesis are *habitus* and *bodily hexis*:

- *Habitus*. Each individual has a *habitus*, defined as a set of 'durable, transposable dispositions, structured structures predisposed to function as structuring structures, that is, as principles which generate and organize practices and representations'.⁵⁰

'The dispositions generate practices, perceptions and attitudes which are "regular" without being consciously co-ordinated or governed by any "rule".'⁵¹ Its relevance to this thesis is that soldiers acquire an identifiably idiosyncratic set of ways of behaving,

and that the idea of *habitus* enables us better to understand the means by which these ways are acquired expressed and passed on, and their deep-seated nature.

- *Bodily Hexis*. Everyone has their own personal way of treating their body. This is a combination of their general attitude to their body and personal ways of holding, moving, clothing and decorating it (one might say, 'organising' and 'deploying' it). Bourdieu's idea of *bodily hexis* is that these personal actions are, like one's *habitus*, the results of accumulated personal experience. The individual's history is literally engraved upon their body, 'a durable way of standing, speaking, walking, and thereby of feeling and thinking'.⁵² The idea of *bodily hexis* is important to the topic of soldiers because it encompasses the observable point that soldiers project a distinctive appearance in the minutiae of their everyday behaviour, and it encourages the observer to search for the processes encoded in this appearance.

Giddens is another important author in the practice tradition. For him, like Bourdieu, social structure is reproduced in the actions of the individual agents, 'It is always the case that the day-to-day activity of social actors draws upon and reproduces structural features of wider social systems.'⁵³ However, he adds his own useful terminology to describe the process. 'Structure' consists in 'rules and resources, or sets of transformation relations, organized as properties of social systems'⁵⁴, while the process of re-creating structure, 'structuration', consists in 'conditions governing the continuity or transmutation of structures, and therefore the reproduction of social systems.'⁵⁵ It is best thought of as a useful term designating the process of expression and reproduction of social structure (or structural systems) in the informed behaviour of 'situated actors who draw upon rules and resources in the diversity of action contexts'.⁵⁶

In setting out his theories of the structure of society and the position of the individuals within it, Giddens wants 'to get away from the characteristic Anglo-Saxon way of conceptualizing structure, where structure is some given form, even a visible form of some sort'⁵⁷. Indeed, he reacts strongly against this idea, calling it 'naive'⁵⁸, and emphasising the

freedom of the agent to choose to act in any one of a number of ways in any situation, possessing the ‘capability to have done otherwise’ in any specific situation⁵⁹.

Although he has a wide following in this view, it is by no means universally accepted, however, as is demonstrated for example by Loyal and Barnes in their recent (2001) critique⁶⁰. The essence of this critique is that Giddens ascribes too much freedom of action to the agent and that it is more realistic, and analytically useful, to treat that action as the result *either* of choice *or* of external constraints that remove the agent’s ability to choose,

‘When a human being acts, it may be regarded as the implementation of choice or as the effect of cause or causes. In either case, the conditions and circumstances of what is done will be relevant to understanding what occurs: they will be taken account of as a choice is made, or else they will feature as the necessary conditions in which a cause will bring about its specific effect.’⁶¹

The importance of this critique is that it helps us to recognise the important tension between ideas of social structure and agency as an ongoing theoretical issue and to balance the concept of a free agent and that of the power of social constraints.

A conceptual model of society and the individual

The social anthropologist Ulf Hannerz gave us a model in 1993 that allows us to conceptualise society and agency in a useful, if very general, way⁶². Drawing on an idea initially proposed in a lecture by Redfield in 1957⁶³, Hannerz considers the influence of the individual (the agent), the ‘collective’ (the system or society), and whatever human universals may or may not exist, on the ‘modes of thought’ and thus behaviour of human beings. He draws up the following table,

	INHERENT	DEVELOPED
INDIVIDUAL (idiosyncratic)	1	2
ENDURING COLLECTIVES	3	4
UNIVERSAL (panhuman)	5	6

Table 1.1. Hannerz's conceptual table of culture ⁶⁴

Notes to Table 1.1. (summarising Hannerz):

1. 'Inherent' means in this context 'Biological in origin, and part of the human nature'.
2. 'Developed' means 'acquired in the course of experience. Not biological in origin'.
3. 'Enduring Collectives' mean 'large-scale cultural groups in which the individual spends the majority, or all, or his or her life'. An example would be 'British society'.
4. The numbering of the boxes is for reference only, and does not imply any relative importance.

This table neatly captures the idea that human rule sets governing attitudes, expectations, and behaviour, arise from a combination of naturally occurring (biological) influences present at birth and experiences during life. In the case of an individual, for example, we may confidently say that some elements of his or her attitudes, expectations and behaviour are there by the nature of the construction of the human mind, and others are there because they have been acquired by experience.

The usefulness of Hannerz's paper is not that it tells us anything new, but that it communicates it in a way that is easy to describe and refer to. We may say, for example, that sociobiologists seek to address box 5⁶⁵, and psychologists address boxes 1 and 2. Similarly, Bourdieu in his consideration of the individual's acquisition of his or her *bodily hexis* addresses box 2, while the 'generating principles' through which it is acquired could be assigned to boxes 3 and 4. Giddens' concept of structuration addresses the interplay between boxes 2 and 4. We may also say that the conduct of human groups arises from boxes 3 to 6, but the differences in the conduct of groups from different origins, say Japanese and British fishermen, probably lie in differences in box 4.

It must be remembered, however, that this table does not assist us in assigning any specific observed behaviour with any certainty to any particular box. In particular, it is no simple matter to judge whether a particular feature of observed behaviour should be placed in the 'inherent' or 'developed' columns as it is usually impossible to differentiate precisely the effects of nature or nurture. Furthermore, the drawing of apparently hard boundaries around the boxes runs counter to the efforts of the Practice theorists to show how practice influences behaviour (collective and individual) and vice versa. We should view the table as merely a useful conceptual tool with which we can discuss the focus or product of research concerning human behaviour, and we will use it as such in Chapter Four.

Structuralism

'Structuralism' is a separate school of thought which originated in France in the 1930s. It is not widely followed in the social sciences at present, but it is described here because it had some influence on the direction and conduct of the research for this thesis.

Structuralism's 'ultimate concern is to establish facts which are true about "the human mind"'⁶⁶. The founder of this intellectual movement within Social Anthropology, Claude Lévi-Strauss (1908-1990), used mathematical principles and ideas from linguistics to probe beneath the surface of human culture and deduce deep-lying thought processes. In his view, every tiny detail of culture is a reflection of these processes, and therefore an informed social anthropologist can get at them by closely examining those details in any part of the culture that he or she chooses. These details are in his terms 'structural transformations' or partial manifestations of the underlying structure: 'the emphasis here is upon the transformability of the relational set rather than upon the quality of the relations as such ... the mathematical idea is abstract and very general; it includes the biologist's notion of structure as a special case.'⁶⁷. However, because the observed details do not plainly and unambiguously reveal the underlying structure, the social anthropologist has to review as many structural transformations of the basic patterns as possible (in other words to look at a very large amount of detail) and select the most illuminating ones for analysis.

An illustration that Leach, the most prominent British structuralist, was fond of using⁶⁸ was that of the various stages of recorded music. The music begins as a pattern of dots on a printed page which the musician turns into sound waves; these sound waves are recorded electromagnetically; the electromagnetic information is physically transferred onto the play-back medium and then turned back into sound waves by the play-back equipment. The 'structure' is that which is common to all the various stages. Those stages are 'structural transformations' of the underlying structure.

The structuralist school has been criticised because of the apparently arbitrary nature of the analysis it gives rise to, and indeed this criticism is hard to refute. Because the analyst is allowed to search for the structure in his own intuitive way, it is perfectly possible that different analysts would come up with quite different ideas about the structure in any particular case. However, the ideas of this school are nevertheless useful: they encourage the social anthropologist to look at the human group in a different way that is complementary to other schools; they stress the importance of the minute details of everyday life; and they offer a unifying theory to explain what can at first sight can seem chaotic material. As Ortner put it in her analysis of anthropological thought over the previous 20 years (mid 1960s to mid 1980s):

'The enduring contribution of Lévi-Straussian structuralism lies in the perception that luxuriant variety, even apparent randomness, may have a deeper unity and systematicity, derived from the operation of a small number of underlying principles.'⁶⁹

The impact of structuralism on this thesis is not immediately apparent, as it does not feature strongly in the presentation and testing of the model. However, the idea the everything and anything that was observed could be a structural manifestation of simpler and deeper patterns was one of the important factors informing the research.

The work of Erving Goffman (1922-1982)

Although it does not represent a school of thought *per se*, the work of Erving Goffman must be mentioned at this point. Goffman fits neither the description ‘sociologist’ nor ‘social anthropologist’. His first degree was in Sociology, his first area of research was as a member of the Social Anthropology Department of Edinburgh University, his PhD was in Sociology, and he held senior posts in the departments of Anthropology and Sociology at the University of Pennsylvania. His main preoccupations included the minutiae of daily life in Western societies, and life in closed institutions. Two of his works are directly important for this thesis. The first, *Asylums* (first published in 1961), is his collection of essays on what he calls ‘total institutions’ in which he looks at daily life in mental hospitals, with reference to other institutions including closed religious orders and, important for this context, military units.⁷⁰ His definition of a ‘total institution’ is:

‘a place of residence and work where a large number of like-situated individuals, cut off from the wider society for an appreciable period of time, together lead an enclosed, formally administered round of life.’⁷¹

It is self-evident that military units will have at least some of the characteristics of a total institution, and so the insights that Goffman gives into life in such places has inevitably illuminated some of the findings of this thesis.

The second important work, from the 1970s, is *Frame Analysis*⁷². He uses the word ‘frames’ or ‘frameworks’ to mean schemata of interpretation in the minds of ‘individual actors’. In his argument, an individual applies these schemata to incidents and encounters in the normal run of everyday events, and they enable him or her to interpret what is going on and to co-operate with others in the same context to act out a ‘normal’ interchange or a give a ‘normal’ response. ‘Frames provide a lore of understanding, an approach, a perspective ... each primary framework allows its user to locate, perceive, identify, and label a seemingly infinite number of concrete occurrences defined in its terms’⁷³. He insists that his emphasis is on the individual, rather than society or social group, and that his book is

‘about the organization of experience - something that an individual actor can take into his mind - and not the organization of society. I make no claim whatsoever to be talking about the core matters of sociology - social organization and social structure.’⁷⁴

Although his analysis is entirely focused at the individual level - the individual organising his or her experience - it is clear that these frames are conceived by him as for use in contexts where those using them are in the presence of others. They are not unique to each individual but consist of expectations and attitudes that are shared by those in any situation and must therefore impinge heavily on the social as well as the individual level. Indeed, he says as much early in the book,

‘Taken all together, the primary frameworks of a particular social group constitute a central element of its culture, especially insofar as understandings emerge concerning principal classes of schemata, the relations of these classes to one another, and the sum total of forces and agents that these interpretive designs acknowledge to be loose in the world. One must try to form an image of a group’s framework of frameworks - its belief system, its “cosmology”.’⁷⁵

As we will see, although it is specifically excluded from *Frame Analysis*, this idea of a shared framework of understandings is one of the central ideas in the model which this thesis presents. Indeed, it could be argued that the main purpose of this model is to provide a means to grasp the ‘classes of schemata’ and their relations to one another in the particular case of regular British soldiers in combat arms units.

Postmodernism

Postmodernism⁷⁶ is an important intellectual strand that has affected all aspects of the humanities over the past 20 years, including all forms of social science. In essence, it recognises that all social inquiry is conducted within a social context and that this context is conditioned by assumptions and webs of power and significance that affect the perceptions of the actors undertaking the investigation. Bluntly, it presents the view that there is no such thing as objective ‘truth’, and that all observed phenomena are altered in the perception of the observer by the mental standpoint of that observer. Whilst there is no ‘school’ of

postmodernism, the ideas which have been labelled ‘postmodernist’ have affected most academic disciplines. It has special implications for the social sciences because they are based so much on observation and inductive reasoning in the first place, and in the second place on the attempt to achieve a deliberately neutral and objective representation of the findings. If there is no ‘truth’ to find, and if all observations and representations are conditioned by the intellectual viewpoint of the observer, then anything that a sociologist or social anthropologist claims to discover is open to the criticism that it is simply an artifact of his or her mind.⁷⁷

Postmodernism therefore presents an intractable difficulty. Whereas in the past, social scientists could set out with confidence to apply what they thought of as scientific principles to their research and to the presentation of their findings, in the current intellectual climate such confidence would be seen as misplaced. It is therefore important to address this difficulty here in this Introduction.

The approach in this thesis is to make an assumption that the existence or otherwise of a ‘ground truth’ is unknowable, and not to make that the issue at all. As we have noted earlier, this study presents a model which can be used to describe, analyse, and predict soldiers’ behaviour. Furthermore, no exclusivity is claimed for the model, and it is required to do no more than its core functions. No doubt other models can be built from similar data by other observers who come from different backgrounds - and whose perceptions are conditioned in different ways. That is not relevant: what is relevant is that this thesis presents a particular model and its importance should be judged on how well it can be used to carry out its task.

The gathering of data on soldiers’ behaviour is also problematic with respect to Postmodernism. The only access that could be gained to ‘soldiers’ behaviour’ is through observation: my observations as a long term participant in British military life at unit level, those of the soldiers I interviewed, and those who left their impressions behind as written records in the past. It must be accepted that the people who produced these data were speaking from a particular standpoint with their own personal histories and their own points of view, and this of course also includes myself as the principal observer in this study.

The answer to this problem lies in two significant advantages of this current study. First, there is the nature of the data, and in particular its quantity and the variety of its sources. Socially constructed or not, such are the size of the data sets and the number of different sources included in the study that the data are sufficiently extensive for any regularities found in the material to be considered significant. The model is built from such regularities, and its power can be tested against the core requirements to describe, analyse and predict soldiers' behaviour as observed and reported. Even if other observers took the same or different data and detected different regularities and built different models, this model can still be considered a legitimate way of addressing the lives of British soldiers at unit level if it proves to be a useful and revealing tool in illuminating the complexities of their social life.

Second, there is the advantage that both I as researcher and those whose lives I researched occupied the same social milieu and shared a common set of conceptions and assumptions about life at unit level. This meant that there was a harmony between our perceptions, and any distortions that are encoded in the model are likely to have arisen from our shared perceptions. In essence, our shared position enabled me to construct a model that rang as true to the soldiers among whom I researched as it did to me. Whilst we must heed the postmodernist warning that all models are derived from particular social and psychological positions, we may also say with confidence that, distorted or not, the model set out in this thesis serves to represent very well the insider's view and make it accessible to the outsider.

The Theoretical Position of This Thesis

So much for the anthropological and sociological antecedents of this study: it must now be located within the current body of social science.

Although the description of the model and the demonstration of its usefulness (which follow in Chapters Three and Four respectively) are both rich in ethnographic detail, it must not be thought that this thesis attempts a single global ethnography of the combat arms units of the British Army. Such an enterprise would not be possible because the research field would be too big, far in excess of the communities of a few hundred people for which the techniques of Social Anthropology were refined. A lesser purpose is attempted here, but one that will

nevertheless be shown to be interesting and useful. This purpose is to present a model which provides a tool with which to describe, analyse, and predict soldiers' behaviour at regimental duty [i.e., serving in a unit] in the combat arms. This thesis presents an ethnographer's tool, not an ethnography, though its usefulness goes beyond the boundaries of pure ethnography.

Design of the model

As we have seen is true of any model, this model contains assumptions which both make it useable and give it limitations, which are now explored.

The main axis which underlies all the inherent assumptions is the concept of 'social structure'. This is a convenient way of expressing within the model the observed phenomenon that people in groups present regular patterns of behaviour, that their attitudes and expectations seem to be informed - structured - by a body of ideas, rules, and conventions. It therefore provides a way of conceptualising the background to, and framework for, daily life. However, it is not suggested that the model is a complete account of an empirical reality, or that it proposes the existence of a powerful and impersonal force that holds individuals in the sort of grip that Durkheim is accused of suggesting in his concept of 'society'.

In the absence of any standardisation of social anthropological terms, there is no agreed general definition of 'social structure' in the social anthropological literature. This has made it necessary, for the sake of analytical rigour, to generate a specific definition for use in this study so that the model could be developed and tested. This definition was generated with reference to two basic works of British Social Anthropology from the 1960s, by John Beattie⁷⁸ and Lucy Mair⁷⁹, and is as follows:

'Social structure' is a shared body of ideas, rules, and conventions of behaviour which informs groups of people or individuals how to organise and conduct themselves vis-à-vis each other. Social structures therefore provide the indispensable background to, and framework for, daily life.

In this model, 'social structure' is not assumed necessarily to comprise a single unified and coherent body of ideas, rules, and conventions of behaviour, but potentially to consist in a number of subsets of such entities, as we will see in Chapter Three, the operating subset being

determined by the context of the moment. There is no direct equivalent of this model in the social scientific literature about soldiers, but there are two important precedents in other areas of social science.

The first is Geertz's description of the peculiar, complicated, and extraordinarily diverse village structures that he found in Bali. He showed that the different structures all bore a family resemblance as they were all derived from what he called seven interwoven 'planes of social organization'⁸⁰. The seven 'planes' each consisted of a set of social institutions based on wholly different principles of affiliation, different ways of grouping individuals or keeping them apart. He analysed the structure of social life in these villages as intricate variations on a common set of organisational themes which arise from this constant set of seven interacting and intersecting organisational components. In the terms of this thesis, he identified seven 'social structures'.

The second is Goffman's use of the conceptual tool that he calls 'frames', which we visited earlier. Although, as we saw, he denies that 'frames' apply to the organisation of society his concept may be bound into the idea of 'social structures' in the sense in which that term is used here. The body of ideas, rules, and conventions of behaviour can be conceived as the resources from which an individual builds his or her frames, and which they use in framing a particular situation.

Another principal assumption in the model is that it pictures a combat arms unit as a bounded entity, though not an isolated one. Although Giddens warns against such an idea as artificial⁸¹, pointing out that few social systems have hard edges, it is a useful fiction for the purpose here. As discussed further in Chapter Four, it proves to be a practical working assumption because of the special nature of military units, conforming as they do to many of the criteria for Goffman's 'total institutions'.

A further important feature of the model is that it is focused on norms: collectively held attitudes and expectations and shared mental models of what is seen as natural and normal. Although special attention is paid to the position and experience of the individual throughout the detailed description of the model in Chapter Three, it is how the individual is affected by those norms that is examined, not how he or she acts as an agent within their social group.

The individual's freedom of choice which, as we saw earlier, is so emphasised by Giddens, is given much less attention than the norms.

This approach is particularly useful for a study of the British Army because norms are an important ingredient of everyday life among soldiers and are regularly thrown into relief in the light of daily events in units. Soldiers readily accept the existence and legitimacy of rules, and there is an observable tendency among them, individually and corporately, to want to know what behaviour is 'appropriate' and 'right' and to expect such behaviour from their fellows. Not only are they expected to enforce and conform to the official rules, for example, but there is also pressure on them to 'fit in' with their peers, subordinates and superiors.

Limitations

The two main limitations which arise from the design of the model are the classic limitations of any model of social structure which were identified earlier (page 12). First, there is little room for agency, and second the model, being essentially static, is not well designed to help to explain change. These must be borne in mind when the model is used, and the following research strategies can help.

On the question of agency, it is useful to consider the model to be analogous to a map. Social structure, or in this case a set of 'social structures', can be thought of as a cognitive map of the social terrain in which the individual agent finds himself or herself, but the agents navigate their own path through it in the process of living. Such a concept manages the tension between structure and agency which we examined above. It proposes the existence of a common structured body of rules and shared expectations (the map) within a social group whilst still allowing scope for individuals to act in ways of their own choice, and sometimes in so doing to make changes to the map (the processes we saw above as captured by Giddens in the concept of 'structuration'). The observer using the model should therefore be alert to the ways in which the individuals use it for navigation, and aim to identify the terrain in which there is little choice but to follow the well-trod paths, the terrain which is more open to choice. The observer should also watch out for the rogue agent (a rare but occasionally

encountered creature in the British Army) who is determined to take an unexpected or difficult path.

Although the model is in itself a static device, locked into the present, it can nevertheless be used as a means to detect and predict change, and to examine the likely consequences of future changes.

Where the interest is in measuring changes from the past, the key principle is to treat the current model as a snapshot of life at unit level during the research period. It is possible to detect and describe changes by comparing this snapshot with life in the past, an idea that we explore *inter alia* in Chapters Five and Six. It would also be possible to build other similar models that seek to capture social structures in the British Army in different periods in the past and use them to observe the course of such change. The series of models could be used, as it were, to create a moving image out of a series of still images presented in sequence. This concept is touched upon in Chapter Six and identified as a promising area for future research in Chapter Seven.

Where the interest is in monitoring changes that are currently taking place, the researcher need do no more than compare what he or she observes with what is in the model. Where there are significant discrepancies, the model should be amended, the amendments showing where change has occurred.

Ideas about future change can be explored by running a series of 'what if' scenarios, either by changing important parameters in the soldiers' lives and examining their effect on the model or by changing parts of the model and speculating about the likely effects on the soldiers concerned. An activity of the first type is reported in Chapter Four with respect to predicting changing attitudes to drug abuse, and of the second type is attempted in Chapter Six when we examine the issue of increasing the number of women in combat arms units.

Summary

In summary, then, the theoretical position of the model is as a tool rather than as an ethnography in itself, and like all models it needs to be used sensitively and intelligently

because of its inherent assumptions and limitations. Nevertheless, as we will see, with all its limitations it is a powerful and revealing tool.

SECTION SIX - THE VALUE OF THE STUDY

This study will prove valuable in several fields. First, it will enable a better understanding of the contemporary British Army for those making decisions about its future. It comes at an opportune time, when what seem to be fundamental changes are in the offing. Such changes include the acceptance of a larger number of women into combat units, the acceptance of self-declared homosexuals, and a fundamental idea, expressed in the setting up of the Bett Study⁸², that changes in management practice, terms of service, and structure are called for.

Second, it will also provide a means to promote better understanding of the British Army among the general public who have little direct contact with it, but who help to fund it through the taxes which they pay.

Third, the historical element of this thesis offers new insights to historians of the British Army.

Fourth, it is also likely that this study of formally organised military units will be of relevance to other academic fields, and in particular to Organization Theory.

SECTION SEVEN - METHODOLOGY

As we have seen, the methodology used in this study it is derived from social science techniques, and especially the techniques of Social Anthropology. This section addresses particular methodological approaches used in the research for this thesis.

The Question of Participant Observation

One of the defining characteristics of Social Anthropology⁸³ is fieldwork in the form of participant observation⁸⁴. Here, there are immediately some methodological difficulties because of my position as a serving officer in the British Army throughout the period of the research.

First, it has long been a methodological tradition in Social Anthropology that the researcher examines exotic cultures that are alien to his or her previous experience⁸⁵. The idea behind this tradition is that the outsider has what has been described as 'stranger value'⁸⁶, and will thus be in a position to observe without his or her observations being conditioned by being a member of the culture that it is being observed. Not only will such an outsider notice the significance of mundane features which would otherwise be taken for granted by a member of the group being observed, but he or she should be able to place an interpretation on the data that it is neutral and, it is hoped, scientifically detached.

I cannot claim any natural stranger value in the overall context of the British Army. Although there are important detailed differences in culture between different units and different parts of the same unit (officers' mess, WOs' and sergeants' mess, and so on) I am as much at home in the general cultural milieu that I describe as any other member of the British Army, and so any stranger value or alien viewpoint that I employed had to be artificially created by my own intellectual effort.

Second, a related point, the majority of my informants and I had equal membership of wider British society, and therefore those elements of their behaviour and attitudes which arise from that source - and they must be assumed to be all pervading and significant elements as Bourdieu has demonstrated in his writings about *habitus* discussed earlier - might well have been opaque to both me and them because they were so much a natural part of our social background.

Third, as an officer with no service in the ranks, I have had no direct experience of the life of the non-commissioned officer or private soldier. An outsider might be able to participate as a quasi-equal in the activities of soldiers in a band within the rank structure, as Killworth achieved in his work which was focused at the platoon level⁸⁷ and involved

participating in the activities of recruits, private soldiers, junior NCOs, senior NCOs and subalterns. Equally, an outsider might experience life in a single part of a unit selected by himself, as Hockey did in his study of recruits and private soldiers⁸⁸. As an insider, of the status of commissioned officer, these were not options for me. Therefore, all data that I have gathered on private soldiers and non-commissioned officers have either been conditioned by my status as an officer when I gathered them directly, or, when they were indirectly gathered, have emerged through interview or casual conversation with soldiers and non-commissioned officers in circumstances where the relative differences in rank can be assumed to have had at least some effect on the information gathered.

On the other hand, there are certain positive features of the study which substantially offset these difficulties. The first is its great length. The first consciously academic research observations were made as far back as 1974, shortly after I graduated with a degree in Archaeology and Anthropology from Cambridge University, and they have continued ever since as opportunities have arisen over much of the intervening period. In 1993, the study became more intensive, first as a year's full time research at Cambridge University, Department of Social Anthropology, and thereafter as a formal part-time study at Cranfield University which culminates in the presentation of this thesis. This time span gives an extensive nature to the inquiry which it is not usual in studies at this level. In particular, the experience over such a long period of investigation has provided a fund of background knowledge against which to judge the responses and statements of individuals, and thus to be able to detect particularities arising from differences in rank.

The fact that I, as researcher, shared common membership of British society with those I was researching may well have led to a lack of focus in some of my observations which a true stranger would not have suffered. However, this need not be considered a serious obstacle to the research, which was aimed primarily at the social characteristics of being a *soldier* rather than a participating member of overarching British culture. This is an essentially 'zoomed-in' study into one important facet of the lives of those being researched, and there it is valid precedent for this type of inquiry into British soldiers' lives by British investigators, specifically in the cases of Killworth and Hockey⁸⁹. Similarly, there it is valid

precedent for examining institutions within one's own culture: Howe's book on being unemployed in Northern Ireland is an obvious example.⁹⁰

Furthermore, it is becoming increasingly acceptable in Social Anthropology for the anthropologist to conduct 'anthropology at home'⁹¹. A specific example is Superintendent Malcolm Young's study of the Police in Newcastle, published in 1991⁹². He sees that there are considerable advantages in the observer having personal experience of the culture he or she it is studying,

'it is here that an anthropological observing participation comes into its own, for in living with the semantics of the system the analyst has the potential to undertake a rarely used method of social research. This contains the experience and depth of the insider's knowledge, which Holdaway (1979)⁹³ recognizes it is unlikely to become readily available, simply because "there it is a lack of impetus within contemporary sociology to spend lengthy periods of observation in what may be uncomfortable research situation"⁹⁴.

This feature of my study was noted during the Defence Fellowship phase, when the Professor of Social Anthropology remarked that my research was "interesting because it is unusual, being anthropology from within"⁹⁵.

One of the advantages of studying 'from within' was that, during the periods when I was at regimental duty, I was able completely to blend in to the human group when carrying out participant observation. It is unusual for a social anthropologist to be able to work so completely integrated into the group and this factor can be considered to be a considerable strength in this study.

Another advantage is equal and opposite to the lack of stranger value. This lies in the fact that I shared the basic perceptions and assumptions of my informants, and so the model presented in this thesis is in harmony with the social milieu as experienced by both researcher and researched. Similarly, whilst it is true that I was less likely than a stranger to be able easily to set my observations in an external and detached framework (though I have attempted to do so) I was much less likely than an outsider to import misconceptions into my analysis. As Scheurich points out, in his 1993 book on carrying out research in the postmodern context:

‘[Researchers from outside the culture they are studying] are unknowingly enacting or being enacted by ‘deep’ civilizational or cultural biases, biases that are damaging to other cultures and to other people who are unable to make us hear them because they do not ‘speak’ in our cultural ‘languages’’.⁹⁶

The particular nature of my participant observation, therefore, is a source of potential weakness for this study in its lack of ‘stranger value’, but there are significant compensating strengths.

Techniques Employed for Gathering Data on Contemporary Soldiers

The three major techniques employed for gathering data on contemporary soldiers were observation, interview, and library based research.

Observation

Observation was practised over a much longer period than that covered by the interviews, as it started 19 years before the first interview and has continued to date. The purpose of the observations was to record elements of soldiers’ lives as an anthropologist would, rather than as a soldier might, with the aim of finding out the organising principles behind their behaviour and attitudes. I wrote up field notes from these observations, recording such things as what soldiers said about themselves, how they behaved, how they arranged themselves when in groups, their attitudes to material objects and the juxtaposition of those objects in military contexts, what they sang, what they wrote, and what they drew. During the study I made a consistent policy to separate observations from analytical comments in my notes, in an attempt to minimise the distorting effect of interpretation on the raw observations. For example, on a day when I visited a unit in civilian clothes,

‘At 1425 I was met at the gate by the guard, one of three men on duty at the gate, a young male private. I explained that I had an appointment with his commanding officer at 1430. He examined my ID card. I asked where RHQ was. He said “Battalion HQ it is at the bottom of the road”. He did not call me “sir”’.

Comment [entered in field notes at the time]. He identified me as an outsider, not entitled to “sir” [although he might have deduced my officer status from my dress, accent, and the personal number on the ID card]. This was reinforced by my calling Battalion HQ, “RHQ”.⁹⁷

After 1993, the fieldnotes tended to be more focused, but not entirely so, on observations connected with the current inquiry into social structures.

Interview

The interview material belongs to the intensive part of the study (since 1993). I visited a variety of combat arms units and a recruit training unit and interviewed soldiers rank ranged from private soldier to lieutenant colonel. I also interviewed selected students on the Staff Course who had all spent most of their service so far at regimental duty, and members of the military staff at the Royal Military College of Science whom I felt could contribute special insights. Additionally, in the final phases of the research, I interviewed a small number of soldiers principally to confirm the findings of previous research and to act as a check against missing major changes. The number of one-to-one interviews was 135, with a further six group sessions, and six significant one-to-one conversations from which particular fieldnotes were made (as opposed to general fieldnotes from observations and fleeting discourse). The majority of interviewees were British soldiers because they were the target for the field of study, but other interviews were conducted with Gurkhas and US Air Force personnel to provide a small sample of cross-cultural material.

I varied the selection of interviewees in combat units by either leaving the choice entirely up to the unit hierarchy or by specifically asking for certain types of individual. I used both methods approximately evenly as a control method. My only consistent request was for a spread of ranks, to include private soldiers, junior and senior NCOs, and junior officers. Senior officers tended to offer themselves and I did not need to ask for them. This led to a varied cross-section of interviewees, from highly polished and integrated individuals who were doing well to those in the unit gaol who were being punished for anti-social activity. Interestingly, I found that there was little difference in the nature of the data given by either a

soldier chosen by a superior (often an officer designated by the Commanding Officer to look after me) or one that I specifically asked for, and the degree of the individual's career success did not seem greatly to affect his or her responses either: the same trends were observable in material from all types of interviewee.

The subsequent choice of interviewees at the Royal Military College of Science was entirely directed by me. I selected individuals whom I thought might contribute new material to the study, including a number of female officers and two officers and one warrant officer who had had experience with Special Forces.

Tables 1.2 to 1.5 show the interviews by rank and type of unit:

Rank	Private	Junior NCO	Senior NCO	Warrant Officer	Subaltern	Captain	Major	Lt Col
Arm								
RA	4, <u>1</u>	2, <u>1</u>	2	2		2		1
RE	2	2		1	1	2**	2	1
RAC	2, <u>2*</u>	1		1	1	1, 1**		
R. SIGNALS		3	1	1	<u>1</u>		<u>1</u>	1
AAC	1	1	1*	2		1	2**	1
Guards	1	2	1	1				2
Line Infantry	9	7	1	2	1	3	3**, 3	2, 1**
Paras	4	2	2	2	1	1	2	2
Special Forces				(1)			2	
RLC							<u>1</u>	
Int Corps							<u>1</u>	
AG Corps				1			<u>3</u>	
Totals	26	21	8	13	5	11	20	11

Table 1.2. British Army British Regiments/Corps Personnel - Interviews

Notes to Table 1.2.

1. Total of 115 interviewees, including 11 women.
2. Highlighted figures refer to women.
3. * refers to logistic corps personnel attached to a combat arm unit.
4. ** refers to LE Officers
5. Brackets () contain individuals already entered elsewhere.

Rank	Private	Junior NCO	Senior NCO	Warrant Officer	Subaltern	Captain	Major	Lt Col
Arm								
Gurkha R SIGNALS								<u>1</u>
Infantry	1	3	1	1	1	<u>1</u> , 1	1, <u>1</u>	<u>1</u>
Totals	1	3	1	1	1	2	2	2

Table 1.3. British Army Gurkha Personnel - Interviews

Notes to Table 1.3:

1. Total of 13 individuals interviewed, 4 of them British.
2. Highlighted figures refer to British officers.

Rank	Private	Junior NCO	Senior NCO	Warrant Officer	Subaltern	Captain	Major	Lt Col
Unit Type								
Special Operations Squadron			3	2	<u>1</u>			1

Table 1.4. United States Air Force Unit - Interviews

Notes to Table 1.4:

1. Total of 7 individuals interviewed, one of them female.
2. Highlighted figure refers to women.

Guards	Officers
Line Infantry	Sergeants and warrant officers
	Junior NCOs and privates, two group sessions
Paras	Officers
	Junior NCOs and privates

Table 1.5. Group Interview Sessions

Notes to Table 1.5:

1. All group sessions were with Infantry soldiers:
2. The groups were composed of up to seven individuals.
3. The sessions lasted for about an hour each.

Interviews were semi-structured, in that I developed a suite of questions designed to allow the interviewees to talk about their experiences of and opinions about life in their unit. A representative sample of these questions is at Appendix C. However, the interviews were as unconstrained as possible to allow for new data to emerge, as happened on several occasions. The one common element in virtually all the interviews was that initially each interviewee was asked to describe their military career to date. It was found that this helped in the analysis of what they said by providing a record of personal experiences and, more importantly, it usually set them at their ease and started to allow the words to flow naturally.

One of the concerns which interview material of this kind must raise in the mind of the researcher is the possibility that it is so conditioned by the interview situation that it is not useful for the task in hand. I was aware throughout that my position as a commissioned officer of the same rank as a unit's commanding officer would be bound to influence to some extent what the interviewees said. I addressed this aspect on two levels: the social and physical conditions of the interview, and the analysis of the data produced.

As far as possible, I made the social and physical conditions of the interview as congenial and unthreatening as possible. The majority of the interviews were conducted in private rooms in the barracks occupied by the unit from which the interviewees came. These rooms were usually empty offices allocated to me for the purpose, sometimes rooms within officers' or WOs and sergeants' messes and on a few occasions shelters on training areas. For the majority of the interviews, I wore civilian clothes and sat in a physically and structurally lower position to that of the interviewee. For example, where I was given the use of an office, I sat the interviewee behind the desk and sat myself in what might be described as the 'client's chair' on the other side. I invariably started by saying that what would be said would be kept confidential, that any quotes I made would be anonymous, and that the interviewee could refuse to answer if he or she so chose at any point. Where, as in most cases, the interviews were tape recorded, the interviewee had control of the tape recorder and was able to - and in some instances did - switch it off when they wished their remarks to be off the record. These measures were designed to encourage the interviewee to disregard the differences in rank as far as possible (though at no stage did I pretend to be other than what I was) and to feel that they were in control of the situation.

Analysis of the data was aimed at determining the organising principles behind the interviewees' behaviour and attitudes. As such, it did not particularly matter to me if the interviewee told the absolute truth or not, so long as he or she felt that what they said was convincing (and thus fitted the pattern of life in the unit). Similarly, I did not take any particular element of information as significant in isolation, but only when confirmed by reports from other informants, or by separate observation. For example, when the first senior NCO told me that he allowed his men to use his first name under controlled conditions (something that I had never heard done), I recorded it with a comment that it probably represented idiosyncratic behaviour. However, when other NCOs and soldiers who had never met my original informant told me that the use of first name terms was often sanctioned by sergeants as a leadership tool but never when 'the hierarchy' was present', I realised that I had discovered an interesting and relevant piece of information which was denied to me in my normal life as an officer (and thus by definition a member of 'the hierarchy').

One remarkable feature was noted during the vast majority of the interviews. Whereas in normal conversation I have observed that soldiers' speech is usually marked by regular and frequent use of swearwords, in hardly a single case were these words used during interviews except in reported speech, such as,

"[The platoon commander comes up to the platoon and says] 'We fucked up big style' and then he'll slag the platoon off for maybe 10 minutes and then it will be forgotten about."^{98 99}

And

[of an officer during the Falklands War] "... he'd go round looking at the company's defences etcetera etcetera, but he just would make a point of coming up and talking to a couple of the Toms and asking them what they thought of it. He'd generally get a reply... 'It's fucking crap!' or something like that. He'd come round with a smile and a brew, but he wasn't one of them stupid nod of the head, smile and walk on."¹⁰⁰

This phenomenon must be significant, not only because it is unusual but also because of its remarkable consistency throughout almost all the interviews. Its significance might be that it demonstrated that the soldiers were not speaking from the heart - that they were watching and weighing their words carefully and thus not speaking naturally and spontaneously.

However, the general atmosphere of many, if not most, of the interviews was anything but constrained and oppressive. The speakers appeared to speak spontaneously and, after an occasionally awkward beginning, in a relaxed way and sometimes with considerable relish. Furthermore, on some occasions they said things which we both knew would be taken as disloyal or shameful in an open military context, as in the following:

[Notes from an interview of an infantry soldier about to leave the Army] He thinks joining the Army is a good idea for someone like him, but he might tell a youngster to join one of the corps, rather than his own Regiment so that he could learn a trade that would be useful in civilian life. He quoted the example of the RCT [Royal Corps of Transport, now part of the Royal Logistic Corps], where you get every licence there is! He asked me not to tell anyone that he had been disloyal to his Regiment.¹⁰¹

I concluded that this phenomenon probably indicated that the context of the interviews was a special one, in which the interviewee was taken out of his or her familiar milieu and transported to neutral ground where some of the normal rules and constraints of their lives were temporarily suspended. This view was at least partially confirmed by one group of interviewees who said that they had never had a conversation like this ever before.¹⁰²

The interview material was taken, therefore, as representing what the interviewees genuinely thought and felt at the time, with some understandable and predictable reluctance to reveal the whole truth about their lives and attitudes (surely an impossible task anyway). It was also assumed that, in principle, interview material it is likely to be biased towards the normative - what people expect to happen, what they consider 'normal', or what they believe it is the 'right' way to behave. It was particularly suitable, therefore, for the construction of the model which, it will be recalled, is focused on norms (see pages 25 and 26 above). However, it would be as well to recall once again that, in the practice of everyday life, norms have to be considered as informing, but not compelling, the action of agents and that in the totality of events individuals will sometimes rupture them. This made the material gained by observation all the more important, as it acted as a gross error check on what interviewees said, so that differences could be discussed and, if necessary, challenged.

In keeping with my promise to interviewees to make all quotations unattributable, I have changed all names and have not identified the units in which they were serving. However, when the type of their unit may be significant, I have identified it to the corps or arm level ('Royal Engineers', 'Royal Artillery', 'infantry' and so on).

Library based research

The library based research involved reading published material on the contemporary British Army. A literature review appears in Chapter Two, but suffice it to say at this stage that although much has been written about the British Army as an institution and its relationship to the wider British society, very little has been written about life at unit level. There are thus very few documentary sources against which to balance the views and results encapsulated in this thesis. However, this shortfall was more than made up for by the amount of time spent in participant observation and interviewing.

Techniques for Obtaining Data on Historical British Soldiers

It has already been said that one of the means employed to test the model was to carry out a historical study. The purpose of this study, reported in Chapter Five, was to test the model by applying it to the recorded behaviour of British Soldiers in an environment that is close enough to that for which it was developed but distinctive enough to present a different arena in which to examine it. The predictive function of the model could not of course be tested in retrospect, so this particular study concentrated on whether or not it provided a good means of describing, analysing and *explaining* soldiers' behaviour.

Historical material has long been accepted as a legitimate field of research for social anthropologists¹⁰³. The major challenge in this study was to abstract evidence about social structures from first hand accounts which were not written for the purpose of describing such structures. The task was to deduce principles of social organisation among soldiers and then place the result against the model to test the degree of match or mis-match. The purpose of the present section is to describe the methodology used and comment on its validity.

The span of the separate historical section of the study runs backwards in time from the Korean War (1950-1953) as far as the existence of a sufficient quantity of suitable first hand material allows. In effect, this meant that it could go with confidence to the late eighteenth century, back to which period there is a wealth of first hand material, and with decreasing levels of confidence as far as the English Civil War where only a very small number of first hand accounts by soldiers exist.

The technique was, in essence, to treat letters diaries and memoirs as if they were statements by informants gathered by a social anthropologist. Analysis was carried out on the text, backed up as necessary with research into the operational and socio-political context in which the material was written. The majority of such material used in this research consists of published documents, but some unpublished first hand material produced by members of the Royal Artillery was also used. The bulk of this unpublished material comprises an archive of some 135 letters from 34 different correspondents relating mainly to the Second World War and the Korean War, which I have collected over the past five years as part of a personal 'Unrecorded Heritage' [UH] project. This project was aimed at recording Gunners' day-to-day experiences, and particularly such perishable material as their songs, chants, and anecdotes. Where reference is made to this material it is designated by a pseudonym for the author (in keeping with a promise to keep the material unattributable), followed by 'RA/UH' and the date of the document [Smith, Private J., RA/UH, 12 January 1998]. One particular correspondent, called here 'Jock Hanbury' has been singularly prolific, producing 50 letters and a set of handwritten memoirs¹⁰⁴, which are used extensively in Chapter Five. A notable further unpublished source is my father's memoir of 1939 to 1943, covering his regimental service from subaltern to battery commander¹⁰⁵.

The treatment of first hand material as if it were statements by informants could be challenged because it is far removed from participant observation. As the investigator, I was not present when the material was generated and there was no opportunity to put questions to any of the informants (apart from the authors of Unrecorded Heritage material). There was therefore no means clarify what the individuals said or to question the light in which they portrayed themselves. Whilst all this is true, such a challenge is to be answered by considering the volume and nature of the material that was analysed. The inability to question

the informants is offset by the wealth of the material and the focused nature of the investigation. Furthermore, there is the pragmatic element: whether or not the investigation can be considered Social Anthropology in the purest sense, there is no alternative to this literature based approach to an historical study of such chronological depth because the literature is the only evidence that can be reached.

Data/Theory Interaction

A significant element in this study has been the interaction between data and theory. The theoretical basis of the study remained as fluid as possible so as not to constrain the gathering of data; data were not knowingly distorted to fit theoretical paradigms; and data have been revisited as the theoretical basis has developed.

Concerning the nature of the data, there is an on-going debate in social science about the relative merits of qualitative and quantitative methods. Writing in 1963, Mitchell reflected the prevailing view in the 1960s and earlier¹⁰⁶ in saying that social anthropologists were inclined to ignore the quantitative in favour of the qualitative approach, and he advocated a positive move towards statistics which 'are "still generally avoided today like the mother-in-law"'¹⁰⁷. His subsequent efforts and those of like-minded social scientists¹⁰⁸ have led to an increasing acceptance of quantitative methods in Social Anthropology, but not all social anthropological studies lend themselves to a statistical approach. Numerical methods should be considered simply as part of the investigator's available tool-kit rather than as a *sine qua non* of acceptable investigation. This present study does not lend itself to quantitative analysis in the conventional sense, but it was possible to use a content analysis computer package on data of all kinds. This package is the NUD*IST package by Scolari, Version 4. It is 'designed to aid users in handling Non-numerical and Unstructured Data in qualitative analysis, by supporting processes of coding data in an Index System, searching text or searching patterns of coding and Theorizing about the data'¹⁰⁹. It was most useful in making connections between different elements of data and identifying trends in the data.

Given that there is an absence of statistical evidence in this research, it might be thought that the model which this thesis presents is overly inductive in that it, and the data

upon which it is based, are products of material gathered according to my choice as researcher and analysed according to my selected methodology.

Although there can be no mathematically based proof of the validity of the model, this consideration does not necessarily invalidate it, for two reasons. First, this study is in the main stream of social science in that the bulk of ethnographic inquiries are qualitative in nature, simply because human social behaviour does not lend itself to quantitative analysis,

‘[T]he crucial elements of sociological theory are often found best with a qualitative method, that is, from data on structural conditions, consequences, deviances, norms, processes, patterns, and systems; because qualitative research is, more often than not, the end product of research within a substantive area beyond which few research sociologists are motivated to move; and because qualitative research is often the most “adequate” and “efficient” way to obtain the type of information required and to contend with the difficulties of an empirical situation¹¹⁰.’

A good example of this aspect is given by Young in the context of the Newcastle Police:

‘[A sociologist from the local university] had been given a room adjacent to the charge room and there we fed him a diet of charge sheets from which he took his numerical data on males, females, ages, and numbers of charges for theft, burglary, drunkenness, and the like, which would “tell him nowt about what really happens”. He knew nothing of the negotiations before the charge, nor of the activities with the 8,000-9,000 who were bailed, summonsed, or merely released without any further action. He had nothing on the culture of dealing with the streams of remand prisoners, for any true revelation of bridewell [prisoner induction and processing centre] culture had been thwarted and the academic, or ‘sociologist prig’, had been defeated while believing that he had won. ... His visit was also useful to me, for it further revealed the mythology of seeking any objective statistical truth in this world of negotiation and wheeler-dealing.’¹¹¹

And indeed, the present study is one of those for which the quantitative approach is simply not suitable. The generation of a model of social structures, the written and unwritten conventions by which people live, is not a quantitative task but a qualitative one.

Second, my model arises from a very large quantity of data, as will have become apparent. Whilst these data are not capable of formal quantitative analysis because they are not in a form that could be so analysed, they comprise a considerable corpus of evidence.

This evidence has a logical momentum of its own which is quite sufficient to be used legitimately in the construction of theory, as Glaser and Strauss have pointed out,

‘Most writing on sociological method has been concerned with how accurate facts can be obtained and how theory can thereby be more rigorously tested. In this book we address ourselves to the equally important enterprise of how the discovery of theory from data - systematically obtained and analyzed in social research - can be *furthered*. We believe that the discovery of theory from data - which we call *grounded theory* - is a major task confronting sociology today, for, as we shall try to show, such a theory fits empirical situations, and is understandable to sociologists and layman [*sic*] alike. Most important, it works - provides us with relevant predictions, explanations, interpretations and applications.’¹¹²

I did not adhere to the full methodology of Grounded Theory, with its strict drills and procedures¹¹³ because this methodology appears to have been developed for short, intensive studies, in contrast to my extended and extensive one. However, I followed Glaser and Strauss insofar as I allowed my theoretical conclusions to emerge from the data and in that I followed their principles on ‘theoretical sampling’,

‘Even during research focused on theory, however, the sociologist must continually judge how many groups he should sample for each theoretical point. The criterion for judging when to stop sampling the different groups pertinent to a category is the category’s theoretical saturation. *Saturation* means that no additional data are being found whereby the sociologist can develop properties of the category. As he sees similar instances over and over again. [*sic*] the researcher becomes empirically confident that a category is saturated. He goes out of his way to look for groups that stretch diversity of data as far as possible, just to make certain that saturation is based on the widest possible range of data on the category.’¹¹⁴

No feature was accepted as significant unless it was independently confirmed by other observations or interview material. In effect, a factor was only accepted as informing the model after it had appeared with consistency and coherence in the research material. This method allowed for a systematic analysis whilst simultaneously allowing for the potentially infinite variety of the form and content of individual responses.

Model Building

The model had its origins in an observation which I made in 1974 that soldiers tended to identify themselves as belonging to groups, but that the precise nature of the group and group membership altered with the context. There seemed to be a continuous process of stating, revising and restating structural distance in a situation of physical proximity. For instance, members of different subunits accommodated in the same building would express their distinctiveness from each other but would happily consider themselves part of the same sporting team. Similarly, individuals who were cross posted between subunits would very rapidly shed their apparently deeply felt identity as members of the first subunit and take on the mores and symbols of the new one.

During the course of the ensuing research, an initial model was built, using as its basis the idea of social structure in the structuralist-functionalist sense of the term. This prototype has subsequently been developed and refined during the research, as new data and new elements of theory have emerged, to reach the form in which it is presented in this thesis.

This form follows the general lines set out by Wilson in his studies of ‘Soft Systems’¹¹⁵, areas of human activity that are not amenable to rigorous mathematical analysis or representation in numerical form. The principles that he articulates have been useful in focusing and confirming the work I have undertaken, although his particular interest lies in the representation of the much narrower field of what he calls ‘human activity systems’ (defined as ‘purposeful activity’ within an organisation¹¹⁶). The two most useful of these principles concern resolution and rigour. In the first, he recommends a means of addressing the problem of complexity in the model,

‘It is frequently the case that, for a given situation or for a particular stage in the analysis, a single model is inadequate or too complex to be practicable. ... A way of overcoming this problem is to develop, not a single model, but a hierarchy of models. A concept that is crucial to this type of development is that of *resolution level*, or level of detail. The characteristic that differentiates one level in the hierarchy from another is the degree of detail with which the elements of the model is expressed. It is usual that the highest level in the hierarchy contains a broad description of the situation

(low resolution) while the lower levels contain increasingly more detailed descriptions of less and less of the situation being modelled (high resolution).¹¹⁷

In the second of these principles he stresses the importance of seeking rigour,

Just because we are trying to use ideas and concepts to analyse highly complex, messy and confused areas of real-world activity rather than specific, well-defined problems associated with 'hard' interpretations, we should not allow those concepts and ideas to become equally confused and messy. *It is as important to seek whatever rigour we can in the development and formulation of concepts for application to 'soft' areas.*¹¹⁸

We will see from Chapter Three in which the model is set out that I propose a 'top level' (low resolution) comprising a small number of areas, each of which is subsequently described in detail (higher resolution), and that within one area there is a further model constructed to address a particular area of complexity. This methodology has greatly simplified the process of putting across the information contained in the model. We will also see that I have given rigour to the model by the use of precise terms with consistent and exclusive meanings throughout. These words are differentiated in the text by the use of *italics*. Their usage in this way is an original product of this study.

Testing

We have already seen that it is a general principle of modelling that before a model can be accepted as useful it must be tested to establish its suitability for its purpose and to explore its limits. In this case, we need to ensure that the model is in harmony with the data so that its inherent assumptions and simplifications do not distort them to an unacceptable extent, and to test whether it has a sufficient degree of rigour.

At an early stage in the testing process a fundamental theoretical problem presented itself. A sociological model, as an heuristic abstraction from a mass of observed data, can never be fully 'validated', as this word implies that there is a defined body of known ground truth - full, un-abstracted reality - against which it can be measured. As Sanger has pointed out about the world of human beings, 'the world is exponentially messier than a laboratory and the latter has proven more ambiguous and error-strewn than science would ever

admit'¹¹⁹. I therefore attempted a lesser goal than full 'validation': that of testing the model by setting it against as much observed data as possible, in line with the principles articulated by Parkin and King:

'We begin by building a model. This involves making some assumptions and then working out some implications. We then make some predictions about the world. At this stage we have a theory about the real world. The predictions can now be tested by comparing them with reality - with some observations we wish to explain. If the predictions are consistent with the facts we observe in the real world, we are inclined to think the theory is a good one - though it is possible that it is a bad theory which by fluke predicted well in our test! If the predictions are inconsistent with the real world, we have two choices. One is to discard the theory in favour of a superior alternative based on the same assumptions. The other is to return to the model-building stage, modify our assumptions and create a new model.'¹²⁰

This testing process fell naturally into two parts. The first part consisted in the continuous iterative process of checking the contemporary data against the current state of the model and refining the model accordingly. The second part was the separate process of formally testing the finished model in the historical context. The first part is not reported separately in this thesis, but has been an essential element in the production of Chapters Three and Four, and the second part is reported in Chapter Five. The first part may conveniently be called 'internal testing' because it consists in testing the model with the data generated during the study, and the second part may be called 'external testing' because all the data existed before the study began.

The means by which internal testing was attempted in the present study was to set against the model all the data gathered and look for inconsistencies or discrepancies in the model's power to provide a means to describe and analyse what was observed. Increasingly, from early 1994 onwards, I also discussed the model with members of the British Army (people who are immersed in the life that I was trying to model) and close observers of the Army to see whether or not it rang true to them, following Sanger, who finds that

'analyses of the relationship between events and people achieve greater validity if participants who have been observed in the research, recognize themselves, their motives, their actions and their rationale in the researcher's recordings and reconstructions. Or those outside the research recognize that it echoes, in some

confirmatory way, what they themselves feel to be right, or true or reliable, Or [*sic*] that the research achieves its analytic rigour by the initial comprehensiveness of its data collection techniques.’¹²¹

Where difficulties occurred, and where these difficulties were confirmed by other data, then the model was adapted to take into account the new discoveries. The result is a robust and flexible model which covers the behaviour of modern British soldiers in combat units.

The power of the model to predict soldiers’ behaviour was less easy to test than its capacity to describe and analyse it because fewer opportunities occurred to use the model for this purpose. However, predictions were made from time to time and when the results were known they provided important arenas for internal testing.

The forum for the external test was an historical study, examining British soldiers’ behaviour in selected periods back to the mid seventeenth century. The purpose of the test was to search for cases in which the model failed to answer the purpose of providing a means to describe, analyse and explain (rather than ‘predict’, as the events had already happened) the behaviour of soldiers in combat units. The object of looking for this apparently negative result was to show that the model was rigorous and focused: that it was not so general and self-fulfilling that it only had the appearance of validity with no real substance. The particular forum was selected because by varying the time frame but not the nationality of the soldiers it was minimising the variables. It could, however, be argued that the ‘nationality’ of a soldier in the British Army of the past was different from that of a British soldier today, because British culture has altered in the mean time, and this should be borne in mind during the reading of Chapter Five. To off-set this possible distortion, a range of historical periods was selected to give a series of data points through history starting as recently as the Korean War so that socio-political discontinuities should be apparent if they are significant. In any case, it should be borne in mind that, with all its faults, such a study provides the most culturally relevant and stable diachronic element attainable.

Information cut-off date

Further data was not collected after 31 May 2002, leaving six months for writing up.

SECTION EIGHT - OUTLINE OF CHAPTERS

In Chapter Two, it is shown by means of a literature survey that this study intersects with work already carried out in the areas of Military Sociology and Military Social Anthropology, but its focus on day to day life at unit level places it in a very small field. Within that small field it is unique in that it attempts to consider all parts of the unit, rather than a particular rank band within it. This chapter also explores relevant historical studies and the status of the sources used in Chapter Five.

In Chapter Three, the model is set out and described, and its elements are illustrated with examples from my fieldwork and from other relevant primary sources.

In Chapter Four, the power of the model to analyse, describe, and predict modern British soldiers' behaviour is explored and contrasted with the power of other relevant models to do the same thing.

Chapter Five shows how the model has been tested in the historical study, exploring the ability of the model to describe, analyse and explain the behaviour of British soldiers at various times back to the mid seventeenth century.

Chapter Six addresses the potential for the application of the model to historical and contemporary military issues.

Chapter Seven identifies the major conclusions from the work and looks at its implications for the British Army, for Social Anthropology, and for other academic disciplines.

Notes to Chapter One:

¹ These ingredients are covered in British Army Doctrine publications by the triad of ‘components of fighting power’: the conceptual, moral and physical. See, for example, MOD, *Army Doctrine Publication Volume 1: Operations*, June 1994, p 1-1 to 1-2; MOD, *Army Doctrine Publication Volume 2: Command*, April 1995, fig 1-1 (paragraph 0110); MOD, *Army Doctrine Publication Volume 3: Soldiering*, February 2000, p. 1-3.

² This interest in ‘small scale’ human groups is fundamental to Social Anthropology. See, for example, Beattie, J. *Other Cultures: Aims, Methods and Achievements in Social Anthropology*, London: Routledge & Kegan Paul Ltd., 1966, p. 40, and Mair, L., *An Introduction to Social Anthropology*, Oxford: Clarendon Press, 1965, p. 7.

³ The nature of Sociology as the social science that focuses particularly on ‘advanced’ or modern societies is defined, *inter alia*, in Giddens, A., *Sociology, 4th Edition*, Cambridge: Polity Press, 2001, p. 699, and in Giddens, *The Constitution of Society: Outline of the Theory of Structuration* Cambridge: Polity Press, 1986, pp. xvi-xvii. See also Lewis, D., ‘Revealing, Widening, Deepening? A Review of the Existing and Potential Contribution of Anthropological Approaches to “Third Sector” Research’, *Human Organization*, **58**, 1999, pp. 73-81, this p. 74.

⁴ See Smith T., and Jarkko, L. *National Pride: a Cross-national Analysis*, National Opinion Research Center/University of Chicago GSS Cross-national Report No 19, May 1998, in which Britain is shown to be second only to America in its devotion to the armed services.

⁵ See, for example, Beavor, A. *Inside the British Army*, London: Chatto and Windus, 1990, pp. xvii-xix.

⁶ The prototype of this model was developed during a pilot study carried out at the Staff College reported in Kirke, C., ‘The Anthropological Analysis of Leadership’, Staff College Project, 1981, and subsequently published in Kirke, C., ‘Social Structures in the Peninsular Army’, *RUSI Journal* Summer 1988, pp. 65-71. An improved, interim, version was produced during research under the MOD Defence Fellowship Scheme reported in Kirke, C. ‘Social Structures in the Combat Arms Units of the British Army’, MOD Defence Fellowship, 17 October 1994. This version was the starting point for the research for this thesis. None of this material has previously been offered for a degree.

⁷ The latest published version of the model appears in Kirke, C. ‘A Model for the Analysis of Fighting Spirit in the British Army’ in Strachan, H.(ed.), *The British Army, Manpower and Society into the Twenty-First Century*, London: Frank Cass 2000, pp. 227-241, reproduced at Appendix A. A further refined version, derived from this thesis, appears in a chapter accepted for publication in McConville, T. (ed.), *Defence Management in Uncertain Times*, London: Frank Cass, in press. This chapter is reproduced at Appendix B.

-
- ⁸ Bellamy, C., *The Evolution of Modern Land Warfare: Theory and Practice*, London: Routledge, 1990, p. 244.
- ⁹ Giddens, A., and Turner, J. *Social Theory Today*, Cambridge: Polity Press 1987, p. 164.
- ¹⁰ The Janus model is summarised in *Janus 3.X User's Manual (Revised)*, US Army publication, HQ TRADOC Analysis Center, Fort Leavenworth, Kansas (Revised), November 1993.
- ¹¹ Giddens and Turner, *op. cit.*, p. 164.
- ¹² Loomba, N., *Management - a Quantitative Perspective* London: Collier Macmillan, 1978, pp. 39 and 85. Original emphases.
- ¹³ Chapman, B., *The Science of Society: An Introduction to Sociology*, London: George Allen & Unwin Ltd, 1967, p. 32. Original emphasis.
- ¹⁴ Wilson, B. *Systems: Concepts, Methodologies, and Applications*, Chichester: John Wiley & Sons, 1990, p. xv.
- ¹⁵ Withey, W., 'Physiological Limits to Human Physical Performance: an Overview', *Journal of Defence Science*, **6**, 2001, pp. 178-188, this 179.
- ¹⁶ Throughout this thesis text in square brackets [] has been inserted as an aid to clarify and does not form part of the original text quoted (unless specified).
- ¹⁷ Wilson, B., *Soft Systems Methodology: Conceptual Model Building and its Contribution*, Chichester: John Wiley & Sons Ltd, 2001, p. 4. Original emphases.
- ¹⁸ An account of the biological model is given in, for example, Beattie *op. cit.*, pp. 11, and 49-50.
- ¹⁹ Leach, E., 'Social Structure, the History of the Concept', from D. Stills (ed) *The International Encyclopaedia of the Social Sciences*, Vol 14, USA: Macmillan and Company & the Free Press, 1968, pp. 482-483.
- ²⁰ Giddens, A., *op. cit.*, 1986, pp. 163-164.
- ²¹ *Ibid, passim.*
- ²² Gluckman, M. and Eggan, F., 'Introduction', in Banton, M. (ed.), *The Relevance of Models for Social Anthropology*, London: Tavistock Publications, 1965, pp. ix-xl.
- ²³ Goodenough, W., 'Rethinking "Status" and "Role": Toward A General Model of the Cultural Organization of Social Relationships', Banton, M. (ed.) *op. cit.*, 1965, pp. 1-24, and 20.
- ²⁴ Schneider, D., 'Some Muddles in the Models: Or, How the System Really Works', Banton, M.,

(ed.) *op. cit.*, 1965, pp. 25-85, this p. 73.

²⁵ *Ibid.*, p. 78.

²⁶ Lewis, I., 'Problems in the Comparative Study of Unilineal Descent', in Banton, M., (ed.), *op. cit.*, 1965, pp. 87-112.

²⁷ Ward, B., 'Varieties of the Conscious Model: the Fishermen of South China', in Banton, M., (ed.), *op. cit.*, 1965, pp. 113-137.

²⁸ See, for example: Mair, *op. cit.*, p. 7, citing Tylor, E., *Primitive Culture*, London, 1913, Vol I, p. 1; Hofstede, G., *Cultures and Organizations: Software of the Mind*, London: HarperCollins, 1994, pp. 4-6; Goodenough, W., 'Culture', in Levison, D., and Ember, M., *Encyclopedia of Cultural Anthropology*, Volume 1., New York: Henry Holt and Company, 1996, pp., 291-299, this 292-293.

²⁹ See, for example, Pugh, D., and Hickson, D, *Writers on Organizations* (Fourth Edition), Harmondsworth: Penguin Books, 1971, p. 107, and Robbins, S., *Organization Theory: Structure, Design, and Applications*, New Jersey: Prentice-Hall International Inc., Third Edition, 1990, pp. 437-462.

³⁰ An informative summary of the early origins of the various strands of Anthropology appears in Walker, G., 'Society and Culture in Sociological and Anthropological Tradition', *History of the Human Sciences*, **14**, No. 3., 2001, pp. 30-35.

³¹ See notes 2 and 3 above.

³² Radcliffe-Brown, A., 'Introduction to *Structure and Function in Primitive Society*', reproduced in A. Kuper (ed.), *The Social Anthropology of Radcliffe-Brown*, London: Routledge and Kegan Paul, 1977, pp. 11-24, this pp. 13 and 12, and Singer, M., 'Culture: The Concept of Culture, in D. Stills (ed.) *op. cit.*, pp., 527-543, this p., 530.

³³ Mair, L. *op. cit.*

³⁴ Beattie, J. *op. cit.*

³⁵ Grimshaw, A., and Hart, K., *Anthropology and the Crisis of Intellectuals*, Cambridge: Prickly Pear Press, 1993.

³⁶ A useful and brief summary appears in Jarvie, I., 'The Emergence of British Social Anthropology According to George Stocking', *Philosophy of the Social Sciences*, **31**, 2001, 267-274.

³⁷ Asad, T. 'Anthropology and the Analysis of Ideology', *Man (N.S.)*, **14**, 1979, pp. 607-627, this p. 608.

-
- ³⁸ Grimshaw, A., and Hart, K. *op. cit.*, p. 49.
- ³⁹ Ortner, S., 'Theory in Anthropology Since the Sixties' *Comparative Studies in Society and History*, Vol 26, 1984, pp. 126-166.
- ⁴⁰ Mair, L., *op. cit.*, p. 9.
- ⁴¹ Gluckman, M., and Eggan, F, in Banton, M. (ed.) *op. cit.*, 1965, p. xviii.
- ⁴² Durkheim, E., *The Rules of Sociological Method*, London: Macmillan, 1982, pp. 39-40.
- ⁴³ See, for example, the summary provided by Goodenough, W., 'Anthropology in the 20th Century and Beyond', *American Anthropologist*, **104**, pp. 423-440, 2002, this pp. 431-435.
- ⁴⁴ Asad, T., *op. cit.*, p. 609.
- ⁴⁵ Ortner, S. *op. cit.*, pp. 148-149.
- ⁴⁶ Giddens, A., *op. cit.*, 1986, pp. 1-40.
- ⁴⁷ Fortes, M., personal communication, 1971.
- ⁴⁸ Howe, L. *Being Unemployed in Northern Ireland*, Cambridge: Cambridge University Press, 1990.
- ⁴⁹ Thompson, J., 'Editor's Introduction' to Bourdieu, P., *Language and Symbolic Power*, Cambridge: Polity Press 1991, pp. 1-31, this p. 2.
- ⁵⁰ Bourdieu, P. *The Logic of Practice*, Cambridge: Polity Press, 1990, p. 53.
- ⁵¹ Thompson, J., *op. cit.*, p. 12.
- ⁵² Bourdieu, P., *op. cit.* 1990, p. 70.
- ⁵³ Giddens, A., *op. cit.*, 1986, p. 24.
- ⁵⁴ *Ibid.*, p. 25.
- ⁵⁵ *Ibid.*, p. 25.
- ⁵⁶ *Ibid.*, p. 25.
- ⁵⁷ Giddens, A., and Person, C., *Conversations with Anthony Giddens*, Cambridge: Polity Press, 1998, p. 76.
- ⁵⁸ Giddens, A., *op. cit.*, 1986, p. 16.

⁵⁹ Giddens, A., and Person, C., *op. cit.*, p. 78.

⁶⁰ Loyal, S., and Barnes, B., “‘Agency’ as a Red Herring in Social Theory”, *Philosophy of the Social Sciences*, **31**, 2001, pp. 507-524.

⁶¹ *Ibid.*, p. 519.

⁶² Hannerz, U., ‘When Culture is Everywhere: Reflections on a Favorite Concept’, *Ethnos*, **58**, 1993, pp. 95-111.

⁶³ No reference given.

⁶⁴ Hannerz, U., *op. cit.*, p. 99.

⁶⁵ See, for example, Pope, G., *The Biological Bases of Human Behaviour*, London: Allyn and Bacon, 2000.

⁶⁶ Leach, E. *Lévi-Strauss*, London: Fontana, 1970, p. 7.

⁶⁷ Leach, E. *op. cit.*, 1968, p. 486.

⁶⁸ See for example *ibid.*, p. 486.

⁶⁹ Ortner, S., *op. cit.*, p. 136.

⁷⁰ Goffman, E., *Asylums: Essays on the Social Situation of Mental Patients and Other Inmates*, Harmondsworth: Penguin Books Ltd, 1968.

⁷¹ *Ibid.*, p. 11.

⁷² Goffman, E., *Frame Analysis: An Essay on the Organization of Experience*, Harmondsworth: Penguin Books Ltd., 1974.

⁷³ *Ibid.*, p. 21.

⁷⁴ *Ibid.*, p. 13.

⁷⁵ *Ibid.*, p. 27.

⁷⁶ A good summary of the main elements in Postmodernism is in Grenz, S., *A Primer on Postmodernism* Cambridge: William B. Erdmans Publishing Company, 1996, and Sarup, M., *An Introductory Guide to Post-structuralism and Postmodernism* (Second Edition), London: Harvester Wheatsheaf, 1993.

⁷⁷ See, for example, Sanger, J. *The Compleat Observer? A Field Research Guide to Observation*, London: The Falmer Press, 1996, and Scheurich, J. *Research Method in the*

Postmodern, London: The Falmer Press, 1997.

⁷⁸ Beattie, J. *op. cit.*, Chapter 4.

⁷⁹ Mair, L. *op. cit.* (Chapters 1 and 3).

⁸⁰ Geertz, C., 'Form and Variation in Balinese Village Structure', *American Anthropologist*, **61**, 1959, pp. 991-1012.

⁸¹ Giddens, A., *op. cit.*, 1986, pp xxvi-xxvii.

⁸² Bett, M., et. al., *Managing People in Tomorrow's Armed Forces*, HMSO, 1995.

⁸³ Because this section deals with fundamental aspects of Social Anthropology, single references are given as representative of a much wider body of literature. It would not be practical to give comprehensive references.

⁸⁴ Beattie, J., *op. cit.*, p. 265.

⁸⁵ Mair, L. *op. cit.*, p. 2.

⁸⁶ Beattie, J., *op. cit.*, p. 87.

⁸⁷ Killworth, P., *Culture and Power in the British Army: Hierarchies, Boundaries and Construction*, Ph.D., University of Cambridge, 1997.

⁸⁸ Hockey, J., *Squaddies: Portrait of a Subculture*, Exeter: University of Exeter, 1986.

⁸⁹ Killworth, P. *op. cit.*, 1997, and Hockey, J. *op. cit.*

⁹⁰ Howe, L. *op. cit.*

⁹¹ For a general example, see Jackson, A. (ed.) *Anthropology at Home*, London: Tavistock 1987.

⁹² Young, M., *An Inside Job: Policing and Police Culture in Britain*, Oxford: Clarendon Press, 1991.

⁹³ Young cites Holdaway, S. (ed.), *The British Police*, London: Edward Arnold, 1979.

⁹⁴ Young, M. *op. cit.*, p. 24.

⁹⁵ Strathern, M., personal communication, 1994.

⁹⁶ Scheurich, J., *op. cit.*, p. 1.

⁹⁷ Fieldnotes, 13 December 1993.

⁹⁸ Fieldnotes 14 January 1994.

⁹⁹ In all quotations from interviews, the exact words of the interviewee are used, though I have added punctuation to indicate the flow and pattern of the speech. Pauses in speech are rendered by connecting ‘...’ to the last word spoken, whilst editorial omissions are rendered by ‘...’ separated by spaces other text.

¹⁰⁰ Fieldnotes, 8 February 1994.

¹⁰¹ Fieldnotes, 18 December 1993.

¹⁰² Fieldnotes, 14 January 1994.

¹⁰³ See, for example, Lewis, I. (ed.) *History and Social Anthropology*, London: Tavistock Publications 1968.

¹⁰⁴ Hanbury, J., *Donnie’s War* unpublished memoir of the Second World War, 1939 to 1945, undated, *circa* 1965.

¹⁰⁵ Kirke, R., *Aldershot to Anzio and Back Again, 1938 to 1944*, unpublished memoir of the Second World War, undated, *circa* 1992.

¹⁰⁶ Mitchell, J. ‘Quantitative Methods and Statistical Reasoning in Social Anthropology’ *Sudan Society* **II**, 1963, pp. 1-23.

¹⁰⁷ Quoted from Driver, H. ‘Statistics in Anthropology’, *American Anthropologist* **55** 1953, pp. 42-59, in Mitchell’s paper ‘On Quantification in Social Anthropology’ in Epstein, A., *The Craft of Social Anthropology*, London: Tavistock Publications, 1967, pp. 17-45, this p. 18.

¹⁰⁸ See, for example: Kay, P. (ed.), *Explorations in Mathematical Anthropology*, Cambridge, Massachusetts: M.I.T. Press, 1971; Mitchell, J. (ed.), *Numerical Techniques in Social Anthropology*, Philadelphia: Institute for the Study of Human Issues, Inc., 1980; Bryman, A., and Cramer, D., *Quantitative Data Analysis for Social Scientists*, London: Routledge, 1994; Madrigal, L., *Statistics for Anthropology*, Cambridge: Cambridge University Press, 1998; Hutcheson, G., and Sofroniou, N., *The Multivariate Social Scientist: Introductory Statistics Using Generalized Linear Methods*, London: Sage Publications, 1999; Fielding, J., and Gilbert, G., *Understanding Social Statistics*, London: Sage Publications, 2000.

¹⁰⁹ *QSR NUD*IST Users Guide*, London: Sage Publications Ltd., 1997, p. 2.

¹¹⁰ Glaser, B. and Strauss, A., *The discovery of Grounded Theory: Strategies for Qualitative Research*, London: Weidenfeld and Nicolson, 1968, p. 18.

-
- ¹¹¹ Young, M., *op. cit.*, pp. 116 and 117.
- ¹¹² Glaser, B. and Strauss, A., *op. cit.*, p. 1. Authors' emphases.
- ¹¹³ These drills and procedures are concisely described in Creswell, J., *Qualitative Inquiry and Research Design: Choosing among five traditions*, London: Sage Publications Ltd. 1998, pp. 150-153.
- ¹¹⁴ Glaser, B. and Strauss, A., *op. cit.*, p. 61.
- ¹¹⁵ Wilson, B., *op. cit.*, 1990 and 2001, *passim*.
- ¹¹⁶ Wilson, B., *op. cit.*, 2001, p. 9.
- ¹¹⁷ Wilson, B., *op. cit.*, 1990, p. 318.
- ¹¹⁸ Wilson, B., *op. cit.*, 2001, p. 11. Emphasis in the original.
- ¹¹⁹ Sanger, J., *op. cit.*, p. 5.
- ¹²⁰ Parkin, M., and King, D., *Economics (second edition)*, New York: Addison-Wesley Publishers Limited 1995, pp. 23-24.
- ¹²¹ Sanger, J., *op. cit.*, p. 40.

CHAPTER TWO - LITERATURE SURVEY

SECTION ONE - INTRODUCTION

The literature relating to the relevant elements of social theory and the practicalities of the research used in this thesis have been covered in Chapter One. This chapter presents a review of the literature relevant to the object of the research: life in combat units in the British Army, including the historical dimension used in Chapter Five.

It is notable that such literature is comparatively thin. As Killworth remarks in his social anthropological study of culture and power in the British Army,

‘Examining the product of social science research on the analysis of Western military systems, the researcher is struck by two features: firstly, the low volume of work; secondly, its overwhelming domination by American literature.’¹

echoing an earlier remark by von Zuegg:

‘Very little has been written about the structure of the British Army. The main body of work that has been done is in the field of political science.’²

The first and most fundamental feature of this low volume of work on the British Army is the almost total absence of social anthropological studies. Indeed, the only ones before this thesis that are specifically social anthropological in approach are the work arising from my Defence Fellowship³ and Killworth’s Ph.D. thesis and subsequent paper in *Cambridge Anthropology*⁴. However, this review will consider a wider field than pure Social Anthropology. We shall examine relevant attempts to look at the British Army at unit level in any way that has something in common with the social anthropological approach. This will at least locate this study in the wider literature.

We shall also consider literature resources that are relevant to the testing of the model in the historical domain in selected periods, and briefly look at two similar studies on other British disciplined institutions, one contemporary (the Northumbria Police Force) and one historical (the Georgian Navy).

SECTION TWO - MILITARY SOCIOLOGY

‘Military Sociology’ can be said to have been born with Shils and Janowitz’s seminal study into cohesion in the Wehrmacht⁵. Its identity as a coherent separate discipline emerged during the later 1940s, mainly in America, with the purpose of improving soldiers’ ‘adjustment to military life and hence increased organizational effectiveness’⁶. It has

provided a growing body of literature, but, as Killworth remarked, much of it is concentrated on the American military and therefore not of direct relevance to this study. The main thrusts of Military Sociology have been towards the study of the military institution and its relationship with government, domestic society, and the wider world, rather than the life of soldiers at unit level which is the subject of this thesis. For example, the doyen in this field, Janowitz, said in the Introduction to *Sociology and the Military Establishment* that he seeks to 'Identify more precisely a set of characteristics of military organization that would be useful for comparative analysis ... [and to explore] the consequences of the larger society on military organization'⁷. Similarly, the two fundamental questions he addresses in his paper in Van Doorn's book on *Armed Forces and Society* are the adjustment by 'the military' in western industrialised countries to the existence of weapons of mass destruction and the high political profile of the military in developing nations⁸.

Much of what Janowitz says in *Sociology and the Military Establishment* appears to be remarkably prescient from the present perspective of 30 years of hindsight, with respect to both the American and the British Army. For example, he points out that military institutions in the west are becoming more and more 'civilianized', blurring the distinction between the civilian and the military⁹, and that skill structures and the social basis of authority would change in the face of the increasing importance of technology and technological ability.¹⁰

Prescient or not, the bulk of the writings of the military sociologists are of little direct relevance to this thesis because they deal with social questions at a far broader level than the military unit, which is our focus here. However, there is a thread from the very beginnings of Military Sociology that deals with the importance of small, face-to-face groups which its protagonists call 'primary groups'¹¹ and their role in unit cohesion in combat, and this is self-evidently relevant to this thesis. For example, as Hilmar has put it,

'It should be emphasised that men do not usually function either as isolated individuals or as tiny units of a huge collectivity such as an army or a nation. Instead, the face-to-face groups within which the individual performs his daily activities serve to organize and make meaningful his relationships with the larger military society in which he would otherwise be lost as but one of a multitude of members. ... Military life is essentially a group life; the individual in the armed forces finds himself in enforced, intimate association with others during virtually all phases of his service.'¹²

Similarly, Janowitz writes a chapter in *Sociology and the Military Establishment* on 'Primary Groups and Military Effectiveness'¹³ in which he considers the ingredients of their cohesion and their behaviour under stress. This particular chapter will be examined in detail

later in this thesis and these ingredients will be measured against the elements revealed by use of the model presented in this thesis. Suffice it to say at this point that although his analysis is an important contribution, in the specific context of British soldiers at regimental duty my model reveals further important factors that his analysis does not consider, and shows that some of the conclusions he reaches do not fit the British Army case.

British Military Sociologists have been much fewer in number than American ones, and there is no author of the stature of Janowitz. However, as their work covers the British Army they are potentially of more direct relevance to this thesis. The first to contribute to this small field was Baynes, in his book about 'the soldier' in British society in the late 1960s¹⁴. It was written at a time when the military in general in the Western world was unpopular, particularly with those of military age, following the widespread critical reaction to American involvement in the Vietnam War. It is not so much about 'the soldier in modern society', as its title implies, but rather an examination of the British Army as an institution, its current structure and its future, from a viewpoint within the institution. As such, it has little to say about soldiers at unit level and is therefore of little relevance to this thesis.

Von Zugbach, on the other hand, did pay some attention to the unit level in his examination of the distribution of power and prestige in the British Army, and he produced a model of the influences upon the unit and its members¹⁵. This model has a superficial similarity to some of the elements of the model presented in this thesis and as such it will be examined in detail in Chapter Four. However, his main concern was to show that certain parts of the Army had preserved a controlling interest in it as a British institution and that these parts represented a social and educational elite. His work was therefore almost entirely concerned with officers and is focused at a much higher level than the unit.

Barker attempted a general description of life in the British Army in the early 1980s. He does not declare the extent of his research, but it appears to have involved some interviews with a selection of soldiers of all ranks, and some of their wives, and a series of visits to overseas garrisons. It is a piece of journalism rather than social science, but he tries to provide what he calls in his title 'an unofficial portrait of the British Army'¹⁶. The main themes that emerge from the book are the examination of the Army as an institution, and especially the role of the regimental system as part of that institution, the relationship of the individual to the institution and the relationship of the institution to the wider British society. Analysis, where it occurs, is mainly personal comment without reference to other authorities. Whilst it has a 'feel' about it that is recognisable to the insider, it contains a small number of minor errors of fact and a patchy bias towards some parts of the Army which clearly attracted his approval (for example the Royal Engineers and the Green Jackets) and against others (such as the Household Division) that did not. Although it is an interesting and entertaining book in many ways, it does not cover the same ground as this thesis.

Beevor produced another general description of life in the British Army ten years later. He declares in his book that his research consisted in a nine month study during which he visited eleven major units, nine minor units, thirteen training establishments, five recruiting offices and selection establishments, apart from arms directorates and headquarters¹⁷. As far as unit level research is concerned his work therefore appears to be at least as extensive as mine. He describes several parts of the British Army, showing that he has gained some interesting insights into the recruiting and training process and he makes a commendable attempt to describe the soldier's life in the various arms and services. However, the book's effectiveness is limited by the fact that his outsider status is too obvious: he takes too much at face value and he has a tendency to concentrate on what he sees as the broader social consequences of an increasingly self-seeking society - 'Thatcher's children'¹⁸. Nevertheless, like Barkers' book, it remains a readable and sympathetic description of the contemporary Army, belonging to the tradition of the journalist rather than to the anthropologist.

A recent book that has brought together many threads in British Military Sociology is Strachan's *The British Army: Manpower and Society into the Twenty-First Century*¹⁹. The three sections consider the historical context of the British Army from the late eighteenth century, the Army and contemporary British society, and the influence of social change on fighting effectiveness. This book reflects the main thrust of British Military Sociology in that it is overwhelmingly concerned with the British Army as an institution (though room was found for my paper, containing a version of the model in this thesis, on the social anthropological approach to analysing fighting spirit²⁰). This thread is also exemplified in the writings of Mileham, an increasingly influential British Military Sociologist from the University of Paisley.²¹

An interesting further dimension in British Military Sociology is provided by Jolly, who has studied the links between the Armed Forces, Servicemen, and their families²². Her research goes well beyond the limits of this study and as such is not relevant to this thesis. However, her work gives a useful extra dimension to any conclusions drawn from the use of my model because it sets soldiers in a wider context. The legitimacy of the narrow context of my research is an issue addressed in Chapter Four.

The general approach from Military Sociology, therefore, concentrates at the institutional, rather than the unit or the personal level. However, from time to time military sociologists have provided some insights into areas that are relevant to this thesis, and in a few cases (notably parts of von Zugbach and Janowitz's work) they provide material that can be directly examined using the model, as we will see in Chapter Four.

SECTION THREE - SOCIAL ANTHROPOLOGICAL AND SOCIOLOGICAL STUDIES AT UNIT LEVEL IN THE CONTEMPORARY BRITISH ARMY

This section reviews the work on social interaction on the smaller scale, at unit level or below, in the contemporary British Army. 'Contemporary' in this context means over a timescale that falls within the period over which the research for this thesis has been conducted: 1974 to 2002.

The most important work is undoubtedly Killworth's thesis²³. It was a specifically social anthropological study, and it is recent. He carried out participant-observation research with two infantry recruit platoons and a platoon in a regular infantry unit, using many of the tools and academic conventions that I have used. However, his study differed in many major respects from mine. First, the overwhelming body of his data was gathered among a much smaller sample of soldiers than mine, and among members of a single Regiment, whilst my data were gathered across all the combat arms. Second, his research is confined to the platoon level and below, whilst mine covers the whole unit. Third, and perhaps most significantly, our research aims were different. Whereas my research is directed into the production of a model for the description analysis and prediction of soldiers' behaviour, he investigated the mechanics of power, authority, and prestige. Indeed, although his work used the British Army as a vehicle, his main theoretical concerns relate to a wide area of sociology and social anthropology:

'Although the ethnographic subject of this thesis has been the British Army, the theories discussed have wide ramifications across anthropology, and the conclusions reached in earlier chapters are not restricted purely to the military context. At its broadest, the subject of this thesis has been to discuss how power and culture are related, whether a model can be created that grants autonomy to both concepts, or whether it is possible to reduce the meaning of one to the other.'²⁴

Nevertheless, Killworth's study has considerable importance for this thesis because he had an earlier version of my model at his disposal and he attempted to use it. The views expressed in his thesis appear generally hostile to that version of the model and his detailed criticisms provided a useful aid in testing and improving it during the later stages of the present research. These criticisms will be examined in detail in Chapter Four, but in general they arise from some misunderstandings of the status of the model in the first place and in the second place from the difference in research aims between his work and mine.

Previous to Killworth's work, the best known study was that by Hockey, who also spent time with recruits in training and subsequently at regimental duty in their battalion²⁵.

Although it was an important work of its day because it was the first attempt to describe the life of private soldiers in detail, it suffers gravely from its very narrow perspective, which may have been at least partly due to the very short time of participant observation (three periods of a month) and to Hockey's personal commitment to the concept of the dialectic.

Hockey set himself the task of looking through the eyes of private soldiers only, and so he does not consider the lives of NCOs or officers. The result is a frozen and unbalanced picture. First, there is no acknowledgement that NCOs had once been private soldiers and that many of the private soldiers would be NCOs one day, so it lacked the dynamic element that Practice Theory might have provided. Second, there is no allowance for friendly relations between ranks: his book portrays a dualistic society with squaddies at one pole and the hierarchy at the other. We will see in Chapter Three how wrong this picture is.

Hockey's main thrust is to describe the contrast between the formal command structure with its formal and inescapable official requirements, and the informal unofficial side consisting of the adjustments which privates make to obtain an easier life. In doing so, he makes much of the concept of the 'negotiated order ... in which a relaxed interpretation of military law is traded-off for effective role performance'²⁶. This idea of a 'negotiated order' is heavily criticised by Killworth on the grounds that it oversimplifies the realities of military life²⁷. We will see in Chapter Four how it integrates with my model and how my model amplifies the concept to remove much of the simplifications inherent in it.

Although much of Hockey's body of theoretical assumptions and many of his conclusions may be discarded in the light of Killworth's and my research, he nevertheless provides a window (albeit a misty one) into the lives of private soldiers in the late 1980s which has been useful in refining my research, and particularly in helping to choose the direction of some of the questions asked in the course of interviews. His work has therefore been useful to this thesis, although not perhaps in the way it was originally intended.

Another attempt to look at the soldiers at unit level was that by Stewart, who interviewed British and Argentine soldiers who had taken part in the Falklands War in 1982²⁸. Although there is some irritating evidence of a shallow and incomplete knowledge of the British Army and the Royal Marines in her occasional misuse of technical and organisational terms (which we will examine in Chapter Four) she presents an interesting and useful model of the factors that promote unit cohesion. This model consists in a framework for analysis, 'utilizing the concepts of societal factors, organizational bonding, horizontal (peer) bonding, and vertical bonding.'²⁹ It is of obvious relevance to this thesis, as it addresses many of the same issues as my model does. It will be examined in detail in Chapter Four, where my critique will show that her model has considerable power but that her research is too focused on too small a part of the British Army, her descriptions of the motivating factors for British combat soldiers are in some cases overplayed, and she takes a great deal at face value without detecting the resonances in some of the interview material she quotes. All this means that her

model, whilst being complementary to mine, is less able to describe and analyse the subtleties of the detail of the day to day life of British soldiers.

There is one further work of interest to this thesis which is not so much a study in itself as an interesting source of data. This is Tony Parker's compilation of interview material collected personally by him from 181 informants over 18 months to portray his impression of 'what the British Army is now like in human terms - what sort of people become soldiers and why, how they see themselves, how in turn they look on society'³⁰. The result, by necessity, is edited and selective, but it is nevertheless a moving and intriguing archive of personal statements from infantry soldiers and their families during the time frame covered by my first hand research. It is much to Parker's credit that the selected statements generally ring true to the insider and form an important additional body of information.

SECTION FOUR - HISTORICAL STUDIES

This section sets the historical study, Chapter Five, in its context. The purpose of this study, as we noted in Chapter One, is to test the model in a culturally relevant but separate context. Given that it would not be possible to carry out this test throughout the entire trajectory of the history of the British Army and its immediate antecedents, a series of six periods was chosen, to yield data points along that trajectory. These periods are:

Mid twentieth century (mainly the Second World War)

Early twentieth century (mainly the First World War)

The mid nineteenth century (mainly the Sikh Wars, the Crimean War and the Indian Mutiny)

The end of the eighteenth century and the early nineteenth century (mainly the Peninsular War), for convenience referred to here as the 'Napoleonic period'

The mid to later eighteenth century (mainly the War of the Austrian Succession, the Seven Years War, and the American War of Independence)

The mid seventeenth century (mainly the English Civil War)

It hardly needs to be established that there has been a very large amount written about the British Army and its role in history so only that part of this large corpus which is directly

relevant to this thesis will be discussed here. We will first examine the use of documentary historical sources to provide raw material for specifically anthropological analysis, and then review the small body of literature devoted to social structure and social relationships at unit level in the British Army of the past: those that come reasonably close to the thrust of Chapter Five. Finally we will consider the sort of historical sources available to provide data with which to test the use of the model.

There is a small but rich body of literature that demonstrates that documentary sources can give a useful insight into the fine detail of the daily lives of individuals and small groups in historical settings. Notable in this field is the study by Sabeau of peasant life in the eighteenth and nineteenth centuries in Germany³¹. Drawing on a considerable source of written evidence, including baptism, marriage and burial records, records of land sales, mortgages and taxes, and the recorded proceedings of criminal and civil court actions, he draws a clear and lively picture of life at local level. As he put it himself in his Introduction:

‘What we find in this study are activities, structures, processes, and logics that simply are not visible outside of the local context If we want to know about the content of this “premodern” kinship system, we can only get at it by patiently tracing out genealogies from small geographical regions and piling up examples of kin actually interacting. If we want to recover the tenor of marital relations inside a particular context of production, we have to examine all the anecdotes we can find for the logic of confrontation, the strategies of subsistence and survival, the fabric of rights and obligations, and the coherence of life trajectories. If we want to understand the moral and social relationships which bound together and divided houses and families, we have to examine in detail the tactical language, spatial interaction, and practical everyday exchanges.’³²

The only drawback to this body of evidence is the absence of informal material. Every word that is available was collected for official purposes to do with legal and administrative events in the community. Fortunately, the personalities of the protagonists and the fine detail of their experiences often shine through the formally recorded words, especially in the witness statements recorded in the legal proceedings. However, it is likely that an even more vivid and perhaps more detailed anthropological work could have been produced if there had been personal written material to complement the official.

The work by Ladurie on a community in late thirteenth and early fourteenth century France³³ is another relevant work of history on the small scale. Although it is not a work of social anthropology, as Sabeau’s is, Ladurie provides a detailed account of the social lives of the members of a small mountain village community. The account is remarkably fresh and immediate and provides a convincing snapshot of life at an otherwise remote and inaccessible

time in history. This is made possible by the survival of a body of written evidence comprising a register of procedures and interrogations carried out by the Inquisition in its investigation into the Albigensian heresy in that area. The records were kept under the direction of an individual, Jacques Fournier, who was both rigorous and meticulous. Although this register, like Sabeau's raw material, is another set of formal records, the vast bulk of these records are verbatim statements by the individuals concerned and amount to a considerable body of interview material. Once again, we must be cautious about taking the statements as entirely definitive, this time because of the threatening circumstances under which they were collected, but the book gives us another example of how the minutiae of daily life can be reconstructed from documentary evidence.

Parker has provided us with another book compiled from contemporary written sources concerning a small community in the remote past, this time the inhabitants of the now vanished town of Dunwich in East Anglia³⁴. This work is intriguing and informative and it is written with an informal air, personal and direct, with poetic licence. He tells us that he is providing

‘... truth. Not the *whole* truth. That will never be known. If it ever existed, it now lies somewhere out there at the bottom of the sea, or mingles with the insubstantial breezes that caress the cliff-top grass. But something like the truth.’³⁵

Although this book does not have the academic status of the previous two studies mentioned, it too demonstrates that the minutiae of daily life in the past can, under certain circumstances, be recoverable and, when recovered, subjected to analysis to reveal the social processes going on.

All these three studies exploit a considerable body of written evidence: Sabeau uses legal records, Ladurie uses the transcripts of Inquisition interviews, and Parker uses the ‘amazingly plentiful’ documentary evidence represented by such sources as the *Calendar of Patent Rolls*³⁶. Indeed, it is only the existence of such written evidence, what might be considered as voices from the past, which makes such studies possible, and therefore the historical element of the present study depends on the existence of similar material. Fortunately, there is no shortage of material for most of the period covered (mid-seventeenth century to 1953), as we will see later in this section.

We will now turn to the literature specifically written on social structure and social relationships within combat units of the British Army before 1953, literature which most closely approaches the social anthropological stance to be adopted here.

Many important works on the history of the British Army come close to this type of material. Laffin's *Tommy Atkins*³⁷, for example, attempts convincingly to capture the mood

and concerns of English soldiers over all the selected periods and more. Holmes seeks in *Firing Line*³⁸ to do much the same with a wider target, that of the life and concerns of soldiers in the Western world generically, and in *Redcoat*³⁹ he focuses on British soldiers of the eighteenth and nineteenth centuries. McGuffie's *Rank and File*⁴⁰ covers much the same ground, though he begins his account in 1642. However, none of these important works approaches the degree of resolution required to test the model. For instance, all mention interaction between soldiers of all ranks but none seeks to analyse the different strands in those relationships that the model does, in the way set out in Chapter Three. All mention the business of fighting and being on operations, but none analyses the ideas, rules and conventions of behaviour that informed British soldiers' attitudes to the practicalities of soldiering.

There is also a small group of studies that concentrate specifically on the eighteenth century, attempting to apply a high degree of resolution to aspects of the lives of British soldiers. Prime examples are Houlding's survey of training in the infantry and the cavalry⁴¹, Brumwell's analysis of the British army in America⁴², and Steppler's work on the common soldier in the reign of George III⁴³.

Houlding's and Brumwell's analyses both depict the army on a wider canvas than unit level, looking at it as an institution and an instrument of war. Although, therefore, they contain passages that illuminate the lives of soldiers at regimental duty such passages are incidental to their main themes.

Steppler's research on the other hand tries to capture the life of the common British soldier at unit level, demonstrating that the dominant constraint on him was his low pay. He reviews the system of recruiting, pay, discipline and military justice, and ways round the meagreness of the pay. This is a pioneering work that challenges many common assumptions about life in the Georgian army, but like Hockey he concentrates so heavily on the private soldier that his study does not give any idea of the vertical interaction in British regiments. It is therefore useful as a background to the historical study Chapter Five, but in itself it does not provide much data.

Stevens's research on the Rifle Brigade in the first seventy years of the nineteenth century⁴⁴ also provides insights into regimental life, but her main preoccupation is on the effect that attitudes in the wider British society had on the ways in which Rifle Brigade personnel (and particularly officers) thought. Her main contribution to this study, therefore, is not so much what she finds going on in the battalions of the Rifle Brigade, which is restricted to the effects of the idea of 'gentlemanliness', but rather her demonstration of the influence that the external environment can have on what appears to be an insular and isolated social entity. This consideration is taken up in Chapter Five.

There are, however, three studies that do seek to attain the same degree of resolution as that provided by the model. These studies are those of Sheffield, into officer-man

relationships in the First World War⁴⁵, Baynes, into the social anatomy of a single unit at the start of the First World War⁴⁶, and Odintz's study into the mid-eighteenth century British Army⁴⁷.

Sheffield's work is, as the title states, an investigation into relationships between officers and men in the Edwardian and First World War Army. He makes two major contributions that are relevant to this thesis. First, he shows that the stereotype of the army officer who was idle and had no real relationship with his men is incorrect. Second, he demonstrates the remarkable persistence of pre-war types of relationships between the ranks into and throughout the First World War, when one might expect totally different patterns to emerge because of the huge proportion of conscripts and 'citizens' who were not professional soldiers. Both these findings are in harmony with my model, and, indeed, Sheffield himself has said that he would have found his work easier if he had had my model to hand during his research⁴⁸.

Although Baynes's book, on the 2nd Scottish Rifles and its performance in the Battle of Neuve Chapelle in 1915, is not an academic work, it is a detailed and thorough reconstruction of the lives and personalities of several members of an Edwardian infantry unit. Its purpose is mainly descriptive rather than analytical, which means that its main importance for this thesis lies in its provision of a case study for examination in the light of the model, as we will see in Chapter Six.

Odintz's thesis is designed to produce 'a collective biographical study of some 394 British officers who served in four regiments of foot between 1767 and 1783'⁴⁹. It achieves this purpose in a masterly way, giving a convincing portrait of the mid to late eighteenth century British Army as an institution and bringing out the influence exerted by the mores of the contemporary British society on the lives of the officers in particular. It also draws on a large body of first hand material from which many verbatim quotes are taken. Although it does not use any social scientific model, as the present thesis does, it provides both a useful medium to test and demonstrate the effectiveness of the model in contributing to the examination of the British Army at a remote time in the past, and a means to examine the model's power and its limitations in a wider social context. As we will see, the use of the model on Odintz's own material will yield complementary insights.

Apart from my early and less substantial work on social structures in Wellington's army in the Peninsular War⁵⁰, which used a less mature version of the model presented in this thesis, only these three studies even distantly approach the analysis presented in Chapter Five.

This brings us to the matter of sources. The purpose of Chapter Five is to provide an arena in which to examine the legitimacy and usefulness of the model, rather than as a separate piece of research. There was therefore insufficient time to research very much unpublished primary material, and I have for the most part used easily accessible, published,

sources. However, this is not a significant drawback as the material is still rich in elements that can be examined in the light of the model.

In all cases, first hand material from eye witnesses was used, and virtually all of these eye witnesses are insiders, members of units in the British Army. This material reaches us in the form of diaries and letters, which are contemporary with the circumstances described, and memoirs written after the event (which themselves are often based on diaries) .

It might appear that, in principle, the nearer to the time of the events that a document was written the more it can be expected to reflect the prevailing conditions, whether they are military social structures, operational events, or the political milieu. This consideration would lead to the assumption that letters and diaries are more likely to be higher quality sources than memoirs. This point is made by Lieven in his analysis of the writings of officers in the Zulu Wars who subsequently became high ranking⁵¹,

‘For most people, life unfolds in a patternless way bewildering to its subject. By contrast, the autobiography is typically written by someone looking to find a sense and pattern as life nears its end. It is a crafted work of art seeking to give meaning to a life, even to “create” it.’

Put bluntly: memoirs are too often selectively edited.

Furthermore, it is probably a mistake to put the same weight on letters as on diaries. Most letters from soldiers have been written to people outside the military social structures, wives, for example, or mothers, fathers, brothers, or friends at home, and are usually less rich in military social material: military authors very often make allowances for the fact that the military world is foreign to the intended reader. A case in point is the ‘diary’ written by Lieutenant Hugh Travers during the siege of Ladysmith⁵²: this ‘diary’ was in fact two extended letters that could not be sent because of the siege. These letters are full of events and anecdotes about those of Travers’s brother officers known to his parents but there is nothing whatever about the daily life of himself and his soldiers, or any information about their social relationships. As far as this thesis is concerned, in spite of its encouraging (and misleading) title this publication is a barren source.

This might lead to the conclusion that the only satisfactory sources are diaries, and that letters and memoirs are less likely accurately to reflect the prevailing conditions. Whilst I would agree that this is probably the case with letters to non-military recipients, I suggest that, at least as far as the thrust of this thesis is concerned, it is a mistake to dismiss the memoir entirely. An author of a memoir may impose a selective order on his or her account

of the stream of events and slant the descriptions of their own behaviour, but the undercurrents of social pressure and the general rules informing behaviour (the core of this thesis) are very often still well represented. For example, when Rifleman Harris gives his account of the retreat of Sir John Moore's army to the Atlantic Ports in 1808 he portrays himself in his memoir as on good terms with his Commander:

‘I am proud that, in passing, General Craufurd seldom omitted a word to myself. On this occasion he stopped in the midst and glanced down at my feet:

“What, Harris! No shoes, I see?”

“None sir,” I replied. “They have been gone many days.”⁵³

The significance of this account for this thesis is not so much that Harris portrays himself as on good terms with his General, which may or may not be true, but rather that Harris considers that such a relationship was credible. If it was credible, then such relationships must have been a feature of the general life of the soldiers in question, and therefore an element to be examined in the light of the model.

Thus, whilst diaries are the most productive source of material for Chapter Five, memoirs must also be considered, whilst letters are only likely to provide suitable material if they are exchanged between soldiers.

Fortunately there are enough published sources available to fit the needs of Chapter Five. There is plenty of material from the mid twentieth century going back in time to about 1800, before which date it begins to tail off but there is still a sufficiency as far back as the middle of the eighteenth century. Going further back, by the beginning of the eighteenth century the pool is very small, and first hand accounts by soldiers of the English Civil war are very few indeed. This reflects two historical processes. First, it reflects an increase in literacy during the late eighteenth century and early nineteenth century, so more soldiers were able to record their lives. Secondly, it reflects an observable increase in public interest in the lives of soldiers from the Napoleonic Wars onwards. Increasing interest has led to an increasing keenness on the part of publishers to seek out and publish first hand material written by the soldiers involved.

This first hand material is preferable to the formal legal documents used by Sabeau, Ladurie, and Parker because it is more personal and does not sit under the shadow of the requirements of formal legal or administrative proceedings. It is thus more likely to yield detailed insights into the feelings of the participants. Whilst it would be interesting to compare the impressions gained from this first hand material with those gained from the proceedings of Courts Martial (the nearest equivalent to the material used by Sabeau and Ladurie) it is not necessary to the present research and must wait for another occasion.

There is therefore substantial precedent for an historical study into the daily lives of individuals in the past using written records. More than sufficient first hand written material

exists to carry such a study into the lives of British soldiers in the past, though, looking backwards in time, it begins to fade earlier than about 1800. However, no other study approaches that in Chapter Five: even the scholarly descriptions of the British Army of the past do not cover the ground that will be covered here because, unsurprisingly, they are written from the historical rather than the social scientific viewpoint.

SECTION FIVE - SIMILAR STUDIES OF BRITISH INSTITUTIONS OUTSIDE THE CONTEXT OF THE BRITISH ARMY

Finally, it is useful to cite literature that attempts something similar to the present study but in a different context. The two works that I have chosen as most relevant are Young's study of the Northumbria Police Force⁵⁴, already mentioned in Chapter One, and Rodger's of the Royal Navy during the Seven Years' War⁵⁵. The first is a specifically social anthropological study based on extended participant observation and the second is in the same general mould as Odintz's in that Rodger uses first hand material and official records to describe face-to-face life in a British military institution. They are both investigations of daily life and social relationships within formal organisations and both seek to analyse the social relationships involved in a way that places them in the overall context of social science.

The value of Young's book for this research is that he looked at a formally organised force over a time that overlaps with the timescale of my research, and he successfully used Social Anthropology as the branch of social science for his research. He was also an insider, as I am, being a senior member of the force that he was writing about. He has thus demonstrated a valid parallel to my research position in looking at a disciplined British force composed of people from a similar social and cultural background and in approaching it from a broadly similar perspective. Nevertheless, his work is different to mine in that his approach is not so much to produce a model with which to describe, analyse and predict the behaviour of policemen and women but rather to produce what he calls after Geertz 'thick description'⁵⁶, using a large number of case studies. He also aligned his work more closely than I have done to that of the Structuralist branch of Social Anthropology, searching for indications of liminality and binary oppositions⁵⁷. This latter point highlights the existence of many different valid social anthropological approaches, as explored in Chapter One.

Rodger's work on the Georgian Navy is perhaps on the very edge of the relevant literature. Nevertheless, his attempt to capture the details of the daily lives of sailors in the Seven Years' war has interesting parallels with this thesis, as the following extract shows:

‘A ship’s company, large or small, was a microcosm of society with a manifold division of ranks and ratings, of social class and status, of skills and professions, and of age. The life of the ship can only be understood in relation to these overlapping patterns. In their dealings with one another, in tension and accommodation, in fear and affection, in persuasion and command, men acted within the constraints imposed by the complex internal structure of ship-board society.’⁵⁸

Such a paragraph, suitably reworded to account for the change between eighteenth-century life on the ocean and the twenty-first century life on dry land, would come close to describing the essence of this thesis.

SECTION SIX - CONCLUSIONS

The British Army, both contemporary and historical, has been written about from many different perspectives, but the vast bulk of the social science work has been on the Army as an institution, and its relationships with British Society and British politics. Although Young’s work on the Northumbria Police Force demonstrates that a disciplined British institution is a valid field for academic analysis in the social sciences, very little work has focused on life in contemporary British Army units, and only a small proportion of that has used anything resembling the social anthropological perspective. Even this literature for the most part does not cover the life of the whole unit, or attempt to give a perspective across the combat arms. Apart from my earlier studies, only Killworth has produced a work specifically of social anthropology on any element of the British Army, and that work is aimed in a different direction to the present thesis. Only two works offer models addressing the subject area of this thesis, those of von Zugbach and Stewart: these will be examined in detail in Chapter Four which will show how they are deficient in certain important respects when applied to the minutiae of the daily life of British soldiers in the combat arms.

Written records, both personal and official, have been used successfully to reconstruct the daily lives of face-to-face communities in the past. The assembling of historical material, of which there is more than sufficient for the purposes of this study, against which to test the model in Chapter Five therefore has sound academic precedent. However, nothing resembling this model in this thesis has been used to analyse such material before, apart from my earlier attempt with a less mature version.

It may therefore be concluded that this thesis addresses a gap in the existing literature about the contemporary British Army, and the testing of the model against historical material in Chapter Five also represents a novel approach.

-
- ¹ Killworth, P., *op. cit.*, 1997, p. 7.
- ² von Zugbach, R., *Power and Prestige in the British Army*, Aldershot: Avebury, 1988, p. 1.
- ³ Kirke, C., *op. cit.*, 1994.
- ⁴ Killworth, P., 'The British Army in Northern Ireland: Internal Security Operations, Training, and the Cease-Fire', *Cambridge Anthropology*, **20**, No. 3, 1998, pp. 1-20.
- ⁵ Shils, E. A. and Janowitz, M., 'Cohesion and Disintegration in the Wehrmacht in World War II', *Public Opinion Quarterly*, **12**, Summer 1948, 1948, pp. 280-315.
- ⁶ Coates, C., and Pellegrin, R., *Military Sociology: a Study of American Military Institutions and Military Life* Maryland: University Park Maryland, Social Science Press, 1965, p. 10.
- ⁷ Janowitz, M., *Sociology and the Military Establishment* New York: Russell Sage Foundation, revised edition, 1965, p. 8.
- ⁸ Janowitz, M. 'Armed Forces and Society: A World Perspective', Van Doorn, J, (ed) *Armed Forces and Society*, The Hague: Moulton, 1968, pp.15-38.
- ⁹ Janowitz, M. *op. cit.*, 1965, p. 18.
- ¹⁰ Janowitz, M. *op. cit.* 1968, pp. 27-49.
- ¹¹ A useful brief history of the literature on primary military groups is in Killworth, *op. cit.*, 1997, p. 185 and in Shibusatani, T. *The Derelicts of Company K: a Sociological Study of Demoralization* Berkeley: University of California Press 1978, pp. 10-11.
- ¹² Hilmar, N., 'Chapter XIII: The Dynamics of Military Group Behavior' in Coates, C., and Pellegrin, R., *op. cit.*, p. 311.
- ¹³ Janowitz, M., *op. cit.*, 1965, pp. 77-99.
- ¹⁴ Baynes, Lt Col J., *The Soldier in Modern Society*, London: Eyre Methuen, 1972.
- ¹⁵ von Zugbach, *op. cit.*, pp. 14-35.
- ¹⁶ Barker, D. *Soldiering On: an Unofficial Portrait of the British Army*, London: Andre Deutsch, 1981.
- ¹⁷ Beevor, A., *op. cit.*, p. xii.
- ¹⁸ See, for example, his anecdote about a confrontation between officers on the Junior Division of the Staff Course and a visiting General, *ibid.*, p. 103-104.
- ¹⁹ Strachan, H., (ed.), *op. cit.*, 2000.
- ²⁰ Kirke, C. *op. cit.*, 2000 (reproduced at Appendix A).

-
- ²¹ See for example, Mileham, P., 'Military Virtues 1: The Right to be Different', *Defense Analysis* Vol. 14, No 2, 1998, pp. 169-190, and 'Military Virtues 2: The British Army Ethos' *Defense Analysis* Vol. 14, No 3, 1998, pp. 227-246.
- ²² Jolly, R. *Military Man Family Man: Crown Property* London: Brassey's Defence Publishers 1987, and second edition (revised) London: Brassey's (UK), 1992.
- ²³ Killworth, P., *op. cit.*, 1997.
- ²⁴ *Ibid.*, p. 198.
- ²⁵ Hockey, J., *op. cit.*
- ²⁶ *Ibid.*, p. 159.
- ²⁷ Killworth, *op. cit.*, 1997, pp. 54, 66, 148, 202 and 203.
- ²⁸ Stewart, N., *Mates and Muchachos: Unit cohesion in the Falklands/Malvinas War*, New York: Brassey's, 1991.
- ²⁹ *Ibid.*, p. 132.
- ³⁰ Parker, T., *Soldier, Soldier*, London: Heinemann, 1985, p. 4.
- ³¹ Sabeau, D., *Property, Production, and Family Life in Neckarhausen, 1700 - 1870*. Cambridge: Cambridge University Press, 1990.
- ³² *Ibid.*, p. 37.
- ³³ Ladurie, E., (translated by Bray, B.,) *Montaillou: Cathars and Catholics in a French Village 1294-1324* London: Scolar Press, 1978.
- ³⁴ Parker, R., *Men of Dunwich: the Story of a Vanished Town* London: Collins 1978.
- ³⁵ *Ibid.*, p. 13.
- ³⁶ *Ibid.*, p. 12.
- ³⁷ Laffin, J., *Tommy Atkins: the Story of an English Soldier*, London: White Lion Publishers Limited, 1966.
- ³⁸ Holmes, E. R., *Firing Line*, Harmondsworth: Penguin Books, 1987.
- ³⁹ Holmes, E. R., *Redcoat: The British Soldier in the Age of Horse and Musket*, London: HarperCollins, 2001.
- ⁴⁰ McGuffie, T., *Rank and File: The Common Soldier at Peace and War 1642-1914*, London: Hutchinson & Co. Ltd., 1964.
- ⁴¹ Houlding, J., *Fit for Service: The Training of the British Army, 1715-1795*, Oxford: Clarendon Press, 1981.

-
- ⁴² Brumwell, S., *Redcoats: The British Soldier and War in the Americas, 1755-1763*, Cambridge: Cambridge University Press, 2002.
- ⁴³ Stepler, G., *The Common Soldier in the Reign of George III, 1760-1793*, D. Phil., Oxford University, 1984.
- ⁴⁴ Stevens, C., *The Rifle Brigade 1800 to c.1870: A Study of Social, Cultural and Religious Attitudes*, PhD, University of Sheffield, 1995.
- ⁴⁵ Sheffield, G., *Officer-Man Relations, Morale and Discipline in the British Army 1902-22* Thesis submitted for the degree of Doctor of Philosophy, King's College, London, 1994.
- ⁴⁶ Baynes, J., *Morale: a Study of Men and Courage*, London: Leo Cooper, 1987.
- ⁴⁷ Odintz, M., *op. cit.*
- ⁴⁸ Sheffield, G., personal communication 14 November 1998.
- ⁴⁹ Odintz M., *op. cit.*, p. vii.
- ⁵⁰ Kirke, C., *op. cit.*, 1988.
- ⁵¹ Lieven, M., 'A Victorian Genre: Military Memoirs and the Anglo-Zulu War', *Journal of the Society for Army Historical Research*, 77 (1999), pp. 106-121.
- ⁵² Travers, H. P., 'The Boer War Diary of Lieutenant Hugh Price Travers (Travers, T. (ed.))', *Journal of the Society for Army Historical Research*, 79, Summer 2001, pp. 131 to 144.
- ⁵³ Harris, B., *A Dorset Rifleman: The Recollections of Benjamin Harris* (Hatherway, E. (ed.)), Swanage: Shinglepicker, 1996., p. 110.
- ⁵⁴ Young, M., *op. cit.*, 1991.
- ⁵⁵ Rodger, N., *The Wooden World: An Anatomy of the Georgian Navy*, London: Fontana Press, 1988.
- ⁵⁶ Young, M., *op. cit.*, p. 117.
- ⁵⁷ See, for example, his analysis of the generative practices structured by his early experience and built up into a 'constructed hierarchy of "us" and "them"' *ibid.*, p. 76.
- ⁵⁸ Rodger, N., *op. cit.*, p. 29.

CHAPTER THREE - SOCIAL STRUCTURES IN THE COMBAT ARMS: DESCRIPTION OF THE MODEL

*'Discussion of the future of the armed forces usually involves a concern with technological developments or global strategy. Most members of the armed forces, however, understand and experience the military as a social organization'*¹

SECTION ONE - INTRODUCTION

The purpose of this chapter is to set out the model of social structures in combat arms units which is at the heart of this thesis, a model which conceptually provides a map of the social terrain through which soldiers pass in their daily lives. Its starting point is the definition of 'social structure' which was set out on page 24 above,

'Social structure' is a shared body of ideas, rules and conventions of behaviour which informs groups of people or individuals how to organise and conduct themselves vis-à-vis each other. Social structures therefore provide the indispensable background to, and framework for, daily life.

It will be recalled from Chapter One that for the purpose of this thesis the 'combat arms' consist of the regular units of the Household Cavalry and Royal Armoured Corps, the Royal Artillery, the Royal Engineers, the Infantry, the Royal Signals and the Army Air Corps.

In order to make the model as clear as is practicable in the space available, as many of the areas as possible are illustrated by interview material from my field notes and by my personal recollections and observations. These two types of information generally fulfill complementary purposes: interview material shows the expectations and assumptions of interviewees and how they view their lives, whilst my recollections provide direct access to incidents that I personally saw occurring. The first provides a view that may be modified by the agents' appreciation of how things ought to be, and the second has been consciously constructed to preserve a distinction between fact and comment as far as that is possible. Both contribute in different ways to the identification of the ideas, rules and conventions of behaviour that are the ingredients from which the model is constructed.

The model was worked up for the base case of a combat arms unit which is virtually all male, and in barracks, in the time period 1974 to 1998. For the most part, therefore, non-operational conditions are described, and 'he' is the usual single personal pronoun. It should be noted, however, that an attempt has been made to apply it to the operational environment², and we explore its applicability to other time periods in Chapter Five.

Although the model can be applied to the analysis of particular units in depth, a capacity demonstrated in a small way by the detailed analyses of case studies in Chapter

Four, there is only room here for the reporting and description of general rules and trends across the combat arms: if we invoke the analogy of a map used on page 26, this section is drawn on a small scale. This chapter therefore principally covers the common ground between combat arms units. In the case of a putative future ethnography of a particular British unit or subunit (as exemplified in the case of the Canadian Army by Irwin's recent study of an infantry company³), then the use of this model as a tool for informing that ethnography would represent its application at the greatest conceptual degree of resolution.

SECTION TWO - THE MODEL - AN OVERALL VIEW

Terminology

As far as possible, normal English words have been used in laying out and describing the model, but it has been necessary to invent a small number of specific technical terms with consistent and exclusive meanings that are fundamental to it and are an original product of this study. These terms are printed in *italics* from this point on in this thesis.

Confusion is sometimes caused by the different usages of the word 'regiment' in the context of the British Army. In current British Army practice, if it has an initial capital ('Regiment') it refers to the level above the unit, and with a small initial letter ('regiment') to unit level. The infantry call their units 'battalions', the rest of the Combat Arms call their units 'regiments'. These usages will be used consistently within this thesis.

Social Structures - an outline of the model - top level

Four social structures.

It has been traditional in social science to consider 'social structure' as an overarching entity embracing the whole of a human group. However, the data which I obtained could not be organised under a such a single overarching heading because soldiers' behaviour differed to such a marked degree between different contexts. There simply was no single body of rules, ideas, and conventions of behaviour that could be constructed from the observed behaviour of the individuals or from the interview material. The model presented here therefore departs from the traditional position by identifying a number of distinctly separate *social structures* in combat arms units, each with a distinctly different set of rules, ideas and conventions of behaviour. There are four:

- The *formal command structure*, which is the structure through which a soldier at the bottom of a chain of command receives orders from the person at the top. It is

embedded in and expressed by the hierarchy of rank, the apparatus of discipline, and the formal arrangement of the unit into layer upon layer of organisational elements. It contains the mechanisms for the enforcement of discipline, for the downward issue of orders and instructions and for the upward issue of reports, and it provides the framework for official responsibility and accountability.

- The *informal structure*, which consists in unwritten conventions of behaviour in the absence of formal constraints. It finds particular expression in the patterns of soldiers' informal behaviour and in the web of relationships of friendship and association within the unit, an area which is expanded below into a separate sub-model presented later in this chapter (pages 92 to 107). Individuals come into personal contact with other people within the unit, of any rank, and establish interpersonal relationships with them. Although it might appear at first sight that the quality and intensity of such relationships are determined by free choice on the part of the individual (because they are informal), the network of a soldier's informal relationships is for the most part constrained by his rank and relative position in the unit.

- The *loyalty/identity structure*, which is manifested most notably in a nesting series of different sized groups which are defined by opposition to and contrast with other groups of equal status in the *formal command structure*. The structure itself, the 'body of ideas, rules and conventions of behaviour', consists in the attitudes, feelings and expectations of soldiers towards these groups and membership of them. Thus an infantry soldier would express his identity as a member of his platoon and feel loyalty to it in competition with other platoons of the same company. Where his company is in competition with other companies, these attitudes and feelings would be transferred to the company, rather than the platoon, and this process is continued up to levels beyond the unit (and below the platoon).

- The *functional structure*, which consists in attitudes, feelings and expectations connected with the carrying out of specific tasks and military activities, and the concept of being 'soldierly'. Where groups are formed to carry out such functions, they might exactly reflect the *formal command structure* (which provides an easy and quick means of creating any group within a unit) or they might be independent of it. For example, an infantry platoon (a basic element in the infantry command structure) tends to carry out military functions on exercise and operations as a formed body. In contrast, a 'rear party' which remains in barracks while the rest of

the unit is away (perhaps on leave or on an operational tour of duty) is usually made up of soldiers from all over the unit, brought together into an *ad hoc* grouping.

The necessity for the number of *social structures* in combat arms units to be four emerged from the data: although I searched carefully for evidence that would require the specification of a fifth *social structure*, none appeared. I am therefore confident that for the present case of the regular combat arms four such structures are sufficient.

These four *social structures* can be illustrated in the following diagram, which shows the four bodies of ideas, rules and conventions of behaviour, each separate but contiguous with the other three and all in one overall system,

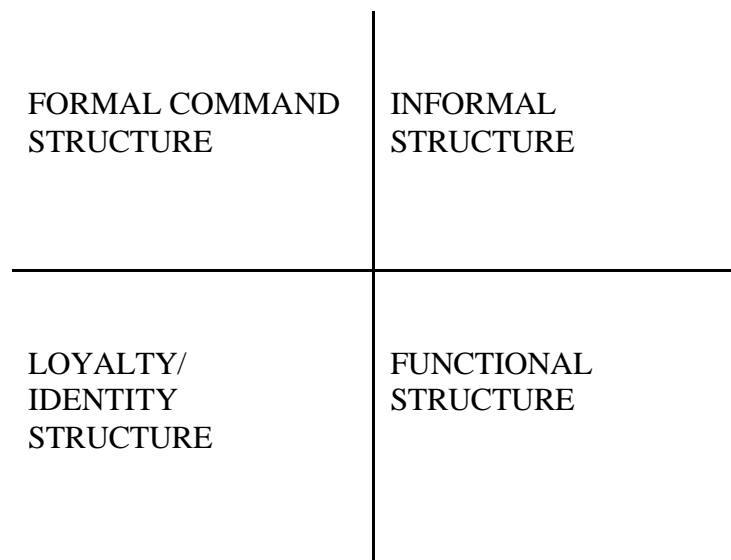

Figure 3.1. *Social Structures* in Combat Arms Units

(Author's diagram)

This apparently simple four-segment diagram represents the top level of the model. Below this top level there is a high degree of complexity. Each of the segments represents a large body of written and unwritten rules and conventions of behaviour and attitudes, all of which are available simultaneously to individuals and groups. As a result, these rules and conventions are interwoven into a complex and intricate whole during the business of daily life, a whole that will appear arcane to an outside observer with no experience of the British Army.

The concept of the operating structure

Although all of the structures are available to inform individual and group action at the same time, I found that soldiers' behaviour tends to follow one structure only in any particular context and at any particular instant. It is therefore implicit in the model that only one structure can be pre-eminent at any one moment and in any one situation, though the others remain as potential resources in the background. For analytical purposes this pre-eminent structure is called the *operating structure*. This is illustrated by the following observation, recollected from my time as a Battery Commander in an artillery regiment in Germany. It stands for hundreds of such incidents in any combat arms unit:

'I was walking from my office in 27 Field Regiment towards the BQMS's [Battery Quartermaster Sergeant] stores. This walk took me across my Battery's gun park where a small group of my soldiers was relaxing and smoking during a break in their work. When I approached them, obviously walking past, the senior soldier present (a lance bombardier), called the men to attention by saying in a loud firm voice "Stand up!" and saluting. The men stood to attention, cigarettes in their hands and therefore out of their mouths. I returned the salute, and said "Carry on Bombardier [plus his name]". The NCO said something to the men who then relaxed and resumed their smoking and chatting.'⁴

Analysis: The *operating structure* for the soldiers was the *informal structure* while they were taking their smoke break. The approach of an officer demanded that they pay him an official compliment. This required them to change *operating structure* to the *formal command structure*. As the officer I also operated in the *formal command structure* by returning the compliment but I then restored them to the *informal structure* as their *operating structure* by telling the NCO to "carry on". The whole business took less than 5 seconds, during which time they transited from one structure to another and back again without hesitation or awkwardness.

This type of analysis using the concept of the *operating structure* is adequate for most of the situations in which soldiers find themselves. However, there are occasions when more than one structure seems to be operating simultaneously and the model of a single *operating structure* seems inadequate. This particular question will be addressed in Chapter Four when the model is assessed.

The concept of the operating group

There is a great deal of potential in the model's four segments to provide the basis for a considerable array of possible groupings. This point can be illustrated by considering an

infantry soldier on duty guarding the gate to his camp as a member of a rear party. He could be a member of a number of groups as delineated by the social structures including:

Formal Command and Loyalty/Identity Structures:

His regiment.

His battalion.

The platoon and company in which he would normally be serving.

Functional Structure:

The rear party, which is a unique and temporary body formed from different parts of the battalion.

Those members of the rear party on duty as gate guards at that time.

Informal Structure:

His group of friends in general (including those away from the camp).

Those people also on rear party duties with whom he is friendly.

However, it would be unrealistic to assume that the soldier was equally committed to all of these groups simultaneously. Indeed, under normal circumstances an individual will feel at any one time that one group in particular demands his attention and energy above all others. As an aid to analysis, the concept of the *operating group* (originally used in my early analysis of Wellington's army in the Peninsular War)⁵ will be used in this thesis to denote this particular group.

Where the model is used rigorously, as it is in this thesis, the description of an *operating group* should contain both an allusion to the *operating structure* and an outline description of the status of the people who form the membership of the group. Thus in this case, where the soldier is on duty guarding the gate, his *operating group* could be described as the 'functional group of gate guards with whom he is working at the time'.

Operating groups can and do change with changing circumstances. Thus, staying with this same soldier on the gate, whereas his *operating group* at the instant of observation is the functional group of gate guards with whom he is working at the time, it will change as soon as he goes off duty, probably to an informal group of rear party soldiers with whom he is friendly.

Description of each of the structures

The next four sections are detailed descriptions of each of the structures. These descriptions are in two main parts, an observer's view of the structure in question and a consideration of the effect of the structure as experienced by the individual soldier.

SECTION THREE - THE FORMAL COMMAND STRUCTURE

*Orders is Orders*⁶

This section outlines the *formal command structure*, which is perhaps the most easily understood of the four social structures, particularly by those outside the armed forces.

Description

As the name implies, this is the social structure that consists in the ideas, rules and conventions of behaviour which govern how soldiers are formally grouped and how they conduct themselves in specifically formal military situations.

The *formal command structure* is expressed in many ways. The one common thread between all of them is that there is an underlying assumption that emotion plays no part in its expression, but that all is governed by formally stated rules, an aspect that Hockey noted, using the Weberian ideal of 'bureaucracy' in his description,

'The Army thus displays numerous bureaucratic features, including a hierarchical authority structure, a formal, highly detailed, almost monolithic body of rules and regulations, and a specialised division of labour.'⁷

Because a complete account of this *social structure* would exceed the space available, a brief description of a number of particular aspects follow, which between them provide an overview of the structure, and each of which encapsulates its basic formal hierarchical nature.

Formal organisational aspects

The *formal command structure* finds organisational expression in the rank structure and the formal division of the unit on a clearly defined hierarchical pattern (See Appendix D). It defines the lines of official responsibility and the chain of command above and below each individual, and the route by which reports from any part of the structure are to reach the Commanding Officer or his appropriate representative. The individual soldier experiences its effects by the obligation it lays upon him to obey orders given by those senior in rank to him, and the rights it confers on him to expect his own orders to be carried out by anyone junior in rank to himself.

The formal organisational elements are probably enacted in their most easily observed form when troops are on parade. Each man, and thus each element of the parading body of troops, has a formal place on parade and the authority figures are obvious by their positions and by what they do. When a unit parades as a unit there are a series of actions that serve to express the unit hierarchy. Initially, the various sub units parade under their non commissioned officers, whilst the officers stand off to the side. The unit is taken over by the Regimental Sergeant Major, who formally hands over to the Adjutant, the personal staff officer to the Commanding Officer and head of discipline in the unit. The Adjutant calls upon the officers to join the parade. When they have done so, he will hand over to the Commanding Officer. A very similar pattern is carried out at a lower level when a sub unit is paraded, with the sub unit sergeant major taking over from the senior NCOs, and handing over to the officer commanding the subunit.

Discipline

Allied to formal organisational elements, there are the disciplinary arrangements in the unit, exemplified in a most concrete way by the Guardroom and its attached cells and exercise yard. The apparatus of discipline derives its power from the law of the land, in the form of the Army Act, and is expressed in the Manual of Military Law⁸ and Queen's Regulations for the Army⁹. The structure is seen in action, for example, in the enforcement of dress regulations, both in the unambiguous setting out in written orders of what is to be worn and in the inspection of soldiers to ensure that what is worn meets appropriate standards. It is also seen in the publication of written daily routine orders issued in the name of the commander at the appropriate level (unit and sub unit), and during summary jurisdiction procedures (called OC's and CO's Orders), and Courts Martial.

Bodily attitudes

Another form of expression is in particular attitudes of the body, *bodily hexis*, in Bourdieu's terms¹⁰. When the *formal command structure* is the *operating structure*, there are a limited number of postures available to the individual, each defined in the Drill Manual¹¹. Until given formal permission to relax by the senior person present, individuals are obliged to either sit or stand 'to attention' if they are stationary, or to move in a prescribed formal manner. If the context is a disciplinary one in which a soldier is undergoing summary jurisdiction further special rules apply, as this example from my experience as a Battery Commander in the mid 1980s¹² illustrates:

Before Battery Commander's Orders, the Battery Sergeant Major (BSM) and I would discuss the accused [in this case, Gunner Smith], and the alleged conduct that brought him to be charged and who witnessed this conduct. Then I would check that the charge sheet had been correctly made out according to the Manual of Military Law (which it invariably was). After that, the BSM and I would take everything off my desk and put it to one side. I would put on my hat, and we would be ready.

The BSM would then put his hat on and leave the room. I would return to my seat behind the desk. After a short pause, I would hear him in the corridor saying in a very loud voice, "Prisoner and escort, SHUN!" Feet would stamp. "Prisoner and escort, quickmarchlefttrightlefttrightleftwheelmartime!" In would come the accused, hatless and without his belt, with one other man of the same rank on either side of him, wearing their hats and their belts. They would be marching at several times the normal pace (something approaching 180 paces a minute) and come to a crashing halt in front of my desk. The BSM would say "Gunner Smith, SIR!". The witnesses, wearing hats, would come in at a more sedate pace and stand to one side, in the 'stand at ease' drill position. I would then formally check the identity of the accused, "You are 24657567 Gunner Smith", to which he would reply "Sir!" and I would read the charge out to him in a prescribed form while he stood at attention in front of my desk. I would end by asking him if he understood the charge. His reply was usually "Yes Sir!", but whatever it was, it was always delivered in a firm and formal tone of voice.

I would then hear the evidence from the witnesses, ask the accused if he understood, and ask him if he had any questions of the witnesses. By the time this was done, I would have made up my mind if the man was guilty of the offence with which he had been accused. I was obliged by the Manual of Military Law to ask him if he accepted my award or elected for trial by Court Martial, which in effect meant that he would be taken to plead his case in front of the Commanding Officer in a similar but more powerful summary court. The CO would make him the same offer at the end of that, so if a man was determined then he could have a Court Martial. None of my soldiers ever went that far.

I would pronounce them guilty or not guilty. If they were guilty I would rift [upbraid] them soundly while they stared fixedly over my head, and I would allot a punishment from a set of prescribed options. I would end by saying in a loud and aggressive voice, "March out!". The BSM would immediately reverse the entry process with "Prisoner and escort, SHUN! Left turn! Quickmarchright wheelleftrightlefttrightlefttright..."^{13 14}

Analysis - Observations on *bodily hexis*:

Dress: I wore my hat throughout the proceedings, though I never did at any other time in my office, and so did the witnesses, the BSM and the escorts to the accused. The accused did not wear a hat.

Use of the voice: Nobody spoke in a conversational tone of voice. The BSM used parade ground volume and turn of phrase; I spoke more firmly than I would normally have done in my office; and all those giving evidence started with "Sir ..." and used a more formal tone and pace than they would have done in a more normal setting.

Holding of the body: All concerned, except myself, used drill manual attitudes. I sat, and the accused stood. In sitting, I held myself more upright than I would normally do.

Movement of the body: I remained stationary throughout the proceedings, in sharp contrast to the swift movement of the escort and the accused.

Badges of rank

Another obvious set of symbols consists in the badges of rank, which are worn in full view on the uniform, as is common in virtually all military forces¹⁵. These badges of rank are often accompanied by distinctions in dress which help to identify the seniority of the individual from a distance. These distinctions vary between regiments and corps, but are exemplified by such things as the wearing of light coloured shirts and brown shoes by officers and warrant officers in contrast to green shirts and black footwear for non commissioned officers and privates. Similarly, where berets are the regimental dress, officers' berets in most regiments carry cloth cap badges whilst those of warrant officers and below are of metal.

Symbols of power surrounding the Commanding Officer

There are certain symbols of power associated with the Commanding Officer, the pinnacle of this structure within the unit. Although the precise detail will vary from unit to unit, these symbols include such things as the convention that all officers in his officers' mess will stand up when he enters the room, his exclusive right to a staff car and driver (a right which he alone within the unit enjoys), and the particular way his office is furnished and decorated. In this latter respect, for example, his desk is usually larger than that of his personal staff officer, the Adjutant, although it will have less paper passing across it. There will also be comfortable chairs in which he can entertain visitors, and there may well be silver ornaments on the desk or surrounding tables. The following is an extract from a description of one commanding officer's office, which is typical enough to illustrate this point for most such offices,

'Symbols of Power. Given that the CO has great power within his own battalion, I looked for symbols of power in his office. I identified the following:

- (1) The size and stillness of the office.
- (2) The large uncluttered desk, implying that
 - (a) He was important enough to justify a big, old-fashioned desk.
 - (b) Other people organise his work for him, bring it in and take it away.
- (3) The silver objects on the table.
- (4) The choice of a low easy chair, which put me physically lower than him in his desk chair.

The sign on the door and the symbols of power identify this office as that of the most powerful person in the regiment.'¹⁶

Terms of address

The *formal command structure* is also expressed in terms of address. Where it is the *operating structure* individuals will refer to each other exclusively by rank and address each other formally. For example, in the context of BC's orders above, I would refer to officers giving evidence as "Mister" and surname if they were subalterns and "Captain" and surname if they were captains. They would call me "Sir". Had the *operating structure* been the *informal structure*, for instance at coffee break in the officers' mess (which may have been only a few minutes earlier), we would all have addressed each other by first names.

Administrative details of daily life

The influence of the *formal command structure* penetrates many small details of daily life. For example:

- The location and type of sleeping quarters are also reflections of the formal command structure. Barrack accommodation for the living-in personnel is normally divided between the officers ('the officers' mess'), the warrant officers and sergeants ('the sergeants' mess'), and the other ranks (ORs). There will probably be a further division within the accommodation of ORs, depending on availability, which will place the private soldiers in communal accommodation, perhaps a ten-man barrack room or a four-man flat, and the junior NCOs in single rooms. The ORs accommodation is almost always arranged so that soldiers from the same sub unit exclusively occupy a discrete portion of an accommodation block, and so that soldiers within the same troop/platoon occupy adjoining rooms.
- Commanders at all levels hold periodic meetings, at which it will normally be clear from their position in the room, and from their right to chair or direct the meeting, that they are the senior person present.
- The time of a soldier of any rank is at the disposal of any person in the chain of command above him.
- Soldiers on duty in barracks eat food in separate rank groups: private soldiers and junior NCOs; sergeants and warrant officers; and officers.

Effect on the individual

The most important implications of the *formal command structure* for the individual can be considered under the following headings:

Position and role. The structure provides an unambiguous location for him within his unit, determined by his rank and the organisational elements to which he belongs. For instance, one soldier described himself to me as ‘a mortarman in Fire Support Company, Number One on 1 Detachment’¹⁷. Similarly, when a lance corporal in an armoured unit described himself as ‘the troop leader’s gunner’¹⁸, he was uniquely identifying himself as a member of a particular vehicle crew in a particular squadron in his particular regiment. However, this position changes with time as the individual is promoted or simply employed in different roles or in another part of the unit, or any combination of the three. It is common practice, for instance, to post infantry soldiers from rifle companies to Support Company when they have gained experience, whether or not they have been promoted:

‘His company [Support Company] is renowned for having a different role to the rifle companies and having a different way of life. They are supposed to get the Senior Privates from the rifle companies: such men are more mature and therefore they do not have to be supervised as much.’¹⁹

An individual’s trajectory through his career and over time can thus be delineated by the various positions that he has held in the *formal command structure*. Here is an illustration from my field notes:

‘[The interviewee] spent his first 2 years in 9 Platoon, of C Company. Then he went to Signal Platoon from 1980 to 1991, where he rose from Private to Sergeant. In 1991 he moved back to a rifle company where he was platoon sergeant of 7 Platoon, in C Company. In Feb 93 he went to Zimbabwe for 6 months loan service. Since then he has been the sergeant in the Signal Platoon.’²⁰

Exclusive chain of assessment. A soldier’s work and his personal conduct on and off duty are examined and assessed by his superiors in the *formal command structure*, who have the exclusive right to confer formal approval or disapproval on him. For instance, a sub unit commander may periodically inspect all the equipment in his sub unit and its documentation and assess how well they are being maintained. He has the authority to initiate disciplinary proceedings against those responsible should either prove below standard. The Commanding Officer may also inspect and discipline the same soldiers, but the other sub unit commanders may not. Similarly, if a soldier behaves badly on or off duty he can only be formally

disciplined by those in his chain of command, even if his offence was committed against someone in authority in another sub unit.

The *formal command structure* also provides the mechanism whereby a soldier's future is decided. It is exclusively his superiors in the chain of command who decide the courses he will undergo to gain qualifications and experience, and they alone decide on his next employment (which could include a major change such as a posting to another unit). Perhaps most important of all, his promotion is controlled by his structural superiors.

Formal communications. This structure provides a communications channel down which he receives the orders which determine the course of his daily life and his immediate future. For example, a soldier reads on sub unit orders the day before what time he will be called in the morning, what his order of dress is to be, when breakfast is available, and what time he must be on parade. On that parade there will be a roll call carried out by an NCO to ensure that all are present who should be, and the soldier will probably be allocated his day's tasks at that parade.

It also provides a means of communications upwards, in that it embodies the channel through which he may make requests. For example, if a soldier wants to go on a particular course or is told that a member of his family is ill and needs his presence, he will make the request for the course or compassionate leave up his chain of command.

In the same way, it provides a mechanism for him to make formal complaints. For example, a soldier who wishes to complain that he or another man is being bullied is expected to ask for an interview with his sub unit commander. He will start the process by making his request to the appropriate NCO, who is duty bound to pass it up the chain of command. However, as we shall see in the next section, other channels of communications in the *informal structure* would probably provide a more effective way of getting his message through to those who can take action to resolve the undesirable situation.

Control and manipulation

I have so far described this structure as a set of rules which have the neutral and absolute force of military law behind them. However, there is scope for members of a unit hierarchy to manipulate these rules. For example, if the BSM had decided that Gunner Smith in my description on pages 84 and 85 should not be charged, then, even if I had heard about it (which I probably would not have done) I would not have over-ruled him. This is not to say, however, that the apparatus of discipline is entirely in the hands of individuals like that BSM. At the time of my example, the Adjutant, as the focus for military discipline in the regiment, kept an overall watch on the application of Military Law in all the parts of the regiment in consultation with the battery commanders so that the same standards and interpretations were applied evenly throughout the unit, and this is typical of most, if not all, British military units.

This process means that the individuals with the greatest formally constituted authority define the limits within which the rules may be flexed and manipulated. Soldiers in a similar position to the BSM in the case quoted make sure that he and they and their NCOs operate within these limits.

Such direct manipulation and control is of course beyond the power of private soldiers, which means that for the most part where the *formal command structure* is the *operating structure* their power to influence events is limited. As we will see, however, this is not necessarily the case in other contexts.

Concluding remarks on the *Formal Command Structure*

This overview of the *formal command structure* has attempted to encapsulate and illustrate its main features. It is noteworthy that this structure has caught the public imagination in a way that the other structures that I will describe have not. Many times when I have revealed to new civilian acquaintances that I am a commissioned officer in the Army they have felt impelled to joke by adopting a rigid posture and making a comic salute. In the same way, people with no knowledge of the Service often make the assumption that officers are fierce creatures who bark orders all the time, stamp their feet and habitually address each other by their rank. It is as if the public's perception of the Army is of a life spent permanently on parade or in summary jurisdiction.²¹ Real life is far from this stereotype, as will become clear from the descriptions of the other three *social structures* which follow.

SECTION FOUR - THE INFORMAL STRUCTURE

*A soldier does not die for his country: he dies for his friends.*²²

*“You are better off being with your mates in combat - being part of a team. Unit pride did not play a part, and Queen and Country did not either.”*²³

Introduction

Because the *informal structure* is the most complex of the four structures in this model, this section is performed the longest and most complex in this chapter.

If the *formal command structure* of a unit were viewed as a vertical system, with the Commanding Officer at the top and the private soldiers at the bottom, the *informal structure* would then be a rectangular system, with spontaneous social interaction running both vertically and horizontally. Unlike the *formal command structure*, it is not governed by any written regulations, and at first sight it appears to be the province of unfettered and unstructured individual choice: a soldier appears to choose who his friends are and whom to shun, and his behaviour off duty and in informal contexts on duty seems to be a matter purely for his personal inclinations. However, there are patterns in soldiers' informal behaviour and in the formation of their informal relationships, and the bundle of rules, customs and attitudes that underlie these patterns is captured in the model of the *informal structure*.

The description of this structure begins with an exploration of the types of informal relationship which exist in a unit. We turn secondly to six other facets of the structure which I have selected for special attention. These selected facets are the formation of informal groups, the effects of the passage of time, informal hierarchies, terms of address, a unit's 'underlife'²⁴, and special informal circumstances. These topics were chosen because they appear more often in the interview material and in my experience than other elements of the *informal structure*. However, they should be considered as examples of significant manifestations of informal military life rather than providing a complete portrait of it. Such a portrait would not be possible in the space available. I could also, for example, have included a treatment of jokes, nicknames, graffiti, and the singing of songs in informal military contexts, all of which are redolent of the *informal structure*. However, they would probably not enhance the thrust of the thesis any further than the material that is included here, which is sufficient for the purpose of this chapter.

The third main part of this section considers the effect of the *informal structure* on individuals, considering private soldiers, NCOs and officers as different categories of agent.

A typology of informal relationships

A key part of the *informal structure* is the network²⁵ of bonds of friendship, association, and informal rights of access. These bonds are described first in this section, after which other important expressions of the structure in the regular pattern of daily life in a unit are addressed.

As with my description of the four structures above, I have found it necessary to create sets of specialist terms, to be written in *italics*, to assist in the description of the *informal structure*. The first set is a group of terms to describe non-sexual informal relationships²⁶. There are five of them: *close friendship*, *friendship*, *association*, *informal access*, and *nodding acquaintance*. Their meanings are described in the following sub sections, and depicted in a diagram that will be built up as the terms are described. The main parameters of this diagram are shown in Figure 3. 2, which is described below.

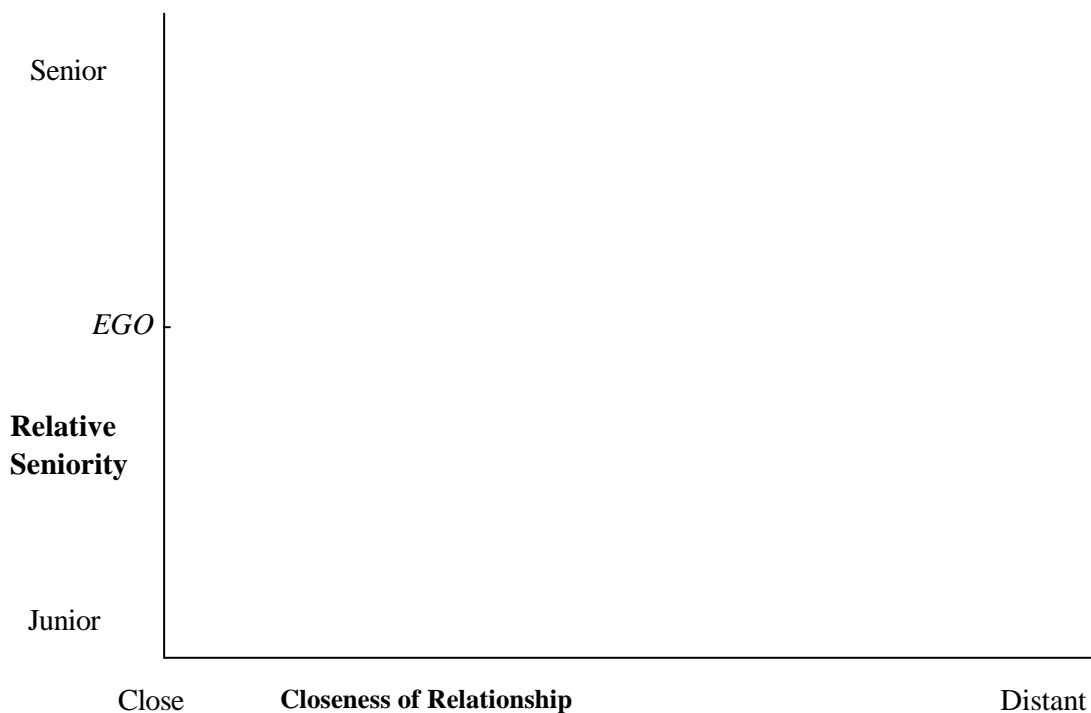

Figure 3. 2: Informal Relationships - Outline Diagram

(Author's diagram)

Notes to Figure. 3.2:

The diagram is drawn on 2 axes:

1. Vertical axis, relative seniority. Any point on the axis is senior in rank to any point below it and junior to any point above it.

2. Horizontal axis, closeness of the relationship. The further to the left, the stronger the relationship, and vice versa.

Soldiers' personal informal relationships fall within the boundaries of the diagram.

"*EGO*" is an individual of no particular rank who has some subordinates and some superiors in the unit. The diagrams in Figures 3.3 to 3.7 that follow summarise the various relationships available to him, the effects of relative rank, and the relative closeness or intensity of the relationships.

Close Friendship

Close friendship consists in a durable relationship that transcends the military environment, where there is a large measure of trust and respect between the parties and few barriers to discussion of highly personal matters. It is a rare and special relationship, the strength of which cannot be underestimated. It is the true 'David and Jonathan' relationship, 'passing the love of women'²⁷, and different in quality from the emotional and physical ties of a deep sexual relationship. *Close friendship* was reflected in a memorable remark reported to me: one soldier speaks in confidence of his best mate, "If he were a woman I would have fucked him by now"²⁸, indicating a deep level of personal commitment without any sexual content.

In my interviews with soldiers of all ranks I established that, for virtually every one, a useful test to identify *close friendship* would be to determine whether the relationship would survive unchanged if one of the parties was prepared to shed tears in the presence of the other: if one is were embarrassed by a friend's tears then he is not a *close friend*.

In transcending the military environment, this relationship also transcends military rank. However, there is a general feeling that such relationships are probably more likely to form between peers, because peers are more often in each others' company informally than those who are separated by significant differences in either age or rank.

The place of *close friendship* in the model is shown in Figure 3.3:

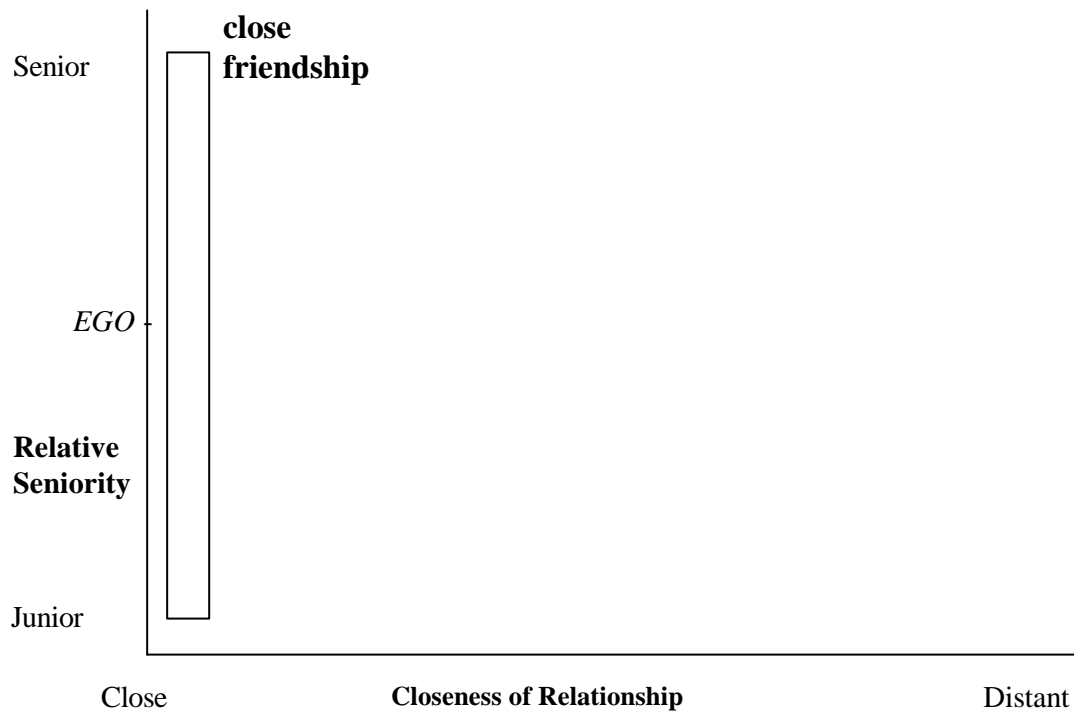

Figure 3.3. Close Friendship

(Author's diagram)

Whilst it is a special relationship, it is also extremely rare. Most interviewees recognised it, either in their own experience or in observing their colleagues, but it was generally agreed that a person could only have a very small number of such relationships in a lifetime, about five at the most. In the words of a warrant officer in an infantry battalion “I’ve maybe made only two or three close friends in my career, though I’ve had plenty of military friends”²⁹, a sentiment echoed by another warrant officer in the Royal Artillery who said that he had no friends but many “acquaintances”³⁰. This means that *close friendship* needs to be identified for the sake of completeness as part of the *informal structure* but it should not be considered as generally significant in the daily life of the majority of soldiers. Other relationships are more common.

Friendship

The next and much more common relationship I have called *friendship*. I use the term here specifically to refer to a less intense informal relationship which is frequently found to exist between soldiers. It can have the appearance of *close friendship*, in that individuals constantly seek each other's company, will help each other if they are in trouble, and will be prepared to share almost anything if the need arises, but it falls short of the depth and intensity of the other relationship. Thus, during a group interview one soldier said of his particular circle of mates that he would be more than prepared to help any one of them: if a bloke was feeling unhappy then his friends would naturally take him out drinking to cheer him up. 'However, there were some things that would not be legitimate topics of conversation between friends. ... if a friend of his said "I think I might be gay" then "I wouldn't want to know!" [said with pantomime of rejection and horrified amusement].'³¹

Bonds of *friendship*, which make up an important element in the *informal structure*, are usually formed within narrow bands of rank. Although there are no formally stated regulations which proscribe friendships growing up between people of widely diverse rank, such relationships are frowned upon because they are held to be potentially compromising for discipline. For example, I was told by an infantry officer in a Scottish regiment:

"We had an officer in [another Regiment] sent to us ... And he came to us, decided that he didn't like the officers' mess, had coffee in the [soldiers'] lines, had sandwiches from the mess and had his lunch down there, and in the end there was complaints from the jocks [soldiers in a Scottish Regiment] through the sergeant major that they just couldn't get away from this chap. And initially his platoon were doing well, winning competitions and things ... but eventually when things started to go wrong they went wrong in a major way and ... unfortunately, when someone lets the officers' side down like that it makes it difficult for everyone else. And I won't tolerate it at all."³²

and more succinctly by a soldier in the same regiment:

"Because they're officers they go out with other officers ... and we stay with our friends."³³

Both these two quotes refer to the 'wrongness' of *friendship* across the commissioned/non-commissioned divide. Here is a private soldier speaking of the limits to *friendship* between those without commissions.

"My group would be in the privates' end of the thing. Probably stretch up perhaps to lance corporals and corporals but not over that."³⁴

and here is a summary of an interview with an infantry sergeant who had broken the rules:

‘His story was that he had been busted [reduced in rank] soon after his first promotion to sergeant because he had been found drinking in the Corporal’s Mess, which is out of bounds to sergeants (except the Battalion Orderly Sergeant). He was down for duty on the Sunday (New Year’s Eve) and would not therefore be able to drink then, so he had decided to drink on the Saturday night. There was nobody in the Sergeants’ Mess, so he had decided to go down town. As he passed the Corporals’ Mess he heard the juke box playing, thought of his old friends there and decided to go in. The Battalion Orderly Sergeant had seen him go in, and he reported it to the RSM [Regimental Sergeant Major]. The RSM then charged him and the CO busted him. There was no question of him behaving badly. Just the very fact that he entered the building not in the line of duty was enough. He had only been a sergeant for 12 weeks, so most of his friends were in the Corporals’ mess. It took him two and a half years to get his rank back.’³⁵

Similarly, when I asked in the early interviews about a putative *friendship* between a warrant officer and a corporal I was told every time that such a relationship would be wrong.

From analysis of the interview material as a whole I concluded that the usual rank limits of *friendship* could be set out thus:

- Anyone can form a *friendship* with anyone of the same rank within the unit.

- Private soldiers may form *friendships* with lance corporals/lance bombardiers, though a *friendship* with a full corporal/bombardier may attract disapproval from above.

- Junior NCOs may form *friendships* with one another.

- Sergeants and staff sergeants/colour sergeants may form *friendships*, but senior NCOs must not have *friendships* with junior NCOs and private soldiers.
 - Warrant officers may form *friendships* with sergeants that they have known for some time, but there will always be a certain distance in the relationship, especially if they are in the same sub unit.

 - The Regimental Sergeant Major is not expected to be on familiar terms with his colleagues in the sergeants’ mess, no matter how well he got on with them in the past.

 - Subalterns (second lieutenants and lieutenants) are expected to form *friendships* with each other, and the senior lieutenants may form *friendships* with captains.

- Majors are expected to form *friendships* among themselves, but are also expected to maintain a certain distance from more junior officers. The degree of distance varies from unit to unit, but it is reflected in the custom that the Commanding Officer may well ask a major to provide him with a draft annual report on those officers in his sub unit. It is hard for a junior officer to form a *friendship* with a person whose opinion of him will have a hand in deciding his future.³⁶

- The Commanding Officer is expected to remain distant from his fellow officers within the unit, as the Regimental Sergeant Major does from his sergeants' mess colleagues.

These are general trends, and there are, of course, some small variations between regiments. In particular, the Foot Guards experience greater constraints than other infantry regiments, whilst, on the other hand, where promotion comes early with technical trade qualifications (as it can do in the Royal Signals for example) then those thus promoted to senior NCO status will not easily shed their *friends* of the same age but junior in rank.

Friendship is constrained not only by rank, but also by structural separation within the unit. This is easily apparent when it is considered that soldiers can only form *friendships* with those they meet reasonably often. For junior soldiers this means that there is in effect an outer organisational line beyond which an individual is unlikely to have the opportunity to make friends.

- Private soldiers tend to confine the majority of their *friendships* within the sub unit to which they belong (and within which the living-in ORs ['other ranks', soldiers below senior NCO rank] are accommodated), with the possible addition of their work mates if they are specialists with a work area outside their sub unit (for example people from different sub units who are qualified as Medical Assistants might work together under the Medical Officer). Analysis of the interview material showed that it would be typical for a private soldier who has been in a unit for about two years to have developed a pattern of 30% of his *friends* in the same platoon/troop, 45% in the rest of his sub unit, and 25% elsewhere. The major individual variation appeared to be in the number of *friends* rather than in this approximate balance. This feature appeared with remarkable consistency during interviews. For all but the Royal Signals the exceptions were confined to those who had recently been posted between units or sub units, those fresh from training, and one individual who was so dissatisfied with Army life that he had been AWOL [absent without leave] for over three months. All of these had the greater balance

of their friends outside the sub unit. Royal Signals interviewees insisted that they formed the majority of their *friendships* inside the troop rather than the sub unit. No full explanation for this was found, though it is probably significant that all Royal Signals interviewees reported that the troops in which they had served were larger than the equivalent elsewhere - well over twice the size of an infantry platoon.

- For junior NCOs there will be the opportunity to make friends outside the sub unit if the unit corporals' club or Junior NCOs' Mess is active, but the old *friendships* from within the sub unit will remain.

For members of the sergeants' and officers' messes the constraints are that they may make *friendships* only within the confines of their messes, with the further restrictions outlined above.

These constraints mean that it is common for a soldier to lose touch with an apparently important friend once they are separated by physical space (when one of them is posted from the unit or leaves the Army) or by structural space (when one of them is posted to a different part of the unit or promoted beyond the scope of *friendship*). However, that is not to say that the *friendship* is necessarily obliterated: it can often be readily revived when the circumstances are right, even if a substantial period of time has elapsed since it was last activated.

Here is an example of restoration of *friendship* after physical separation. The interviewee was a private soldier in the Royal Engineers, who had been trickle posted³⁷ [posted as an individual] from another regiment to his present one:

“There’s a lot of lads here that I was in my last unit with, and nine times out of ten you won’t remember their name. It’ll come to you eventually and then when it does it like picks up and carries on where it broke off.”³⁸

and, after a more drastic separation:

‘The interviewee [a private soldier in the infantry] left the Army in 1988 and spent three years in civvy street. He rejoined three years later, because he had run out of money and he had nowhere to live. The process was that he spent three days at the Depot and took some tests - which he passed - and then went straight to ... [his battalion], and ‘rejoined’ B Company. Initially, he found that most of his old friends had moved on to the mortar platoon. However, he made friends in B Company and fitted in well, seeing little of his mortar platoon friends. But after two months he joined the mortar platoon, and his friendships in the mortar platoon picked up straight away. (He said that he had not been in touch with them while he

was in civvy street). His [new] friendships in B Company faded - they did not go away, but they did go into cold storage.’³⁹

Here is one of restoration after structural separation:

‘I asked [a senior NCO] about the effect of joining the sergeants’ mess. “You say that it will make no difference to your friendships, but it does.” He explained that you start to drink in a different place, you are living in a different place and you are eating in a different place, and all with different people. You form new friendships and the other ones dwindle. However, when the friends with whom he had lost touch got promoted to the mess they just picked up where they left off.

Comment: This means that the friendships that he had with people outside the sergeants’ mess necessarily went into cold storage, only to be got out when those friends joined the same social environment of the sergeants’ mess.’⁴⁰

An infantry sergeant summed up the situation well by saying that each person would find different companions when they were separated, but the *friendship* would still be there.⁴¹

Finally, length of service can be important. I observed, and confirmed during interviews, that soldiers do not generally make *friendships* with men who are very much their junior or senior in experience. This may well be connected with the idea which I call the ‘*pecking order*’ below.

Figure 3. 4 shows *friendship* in the model:

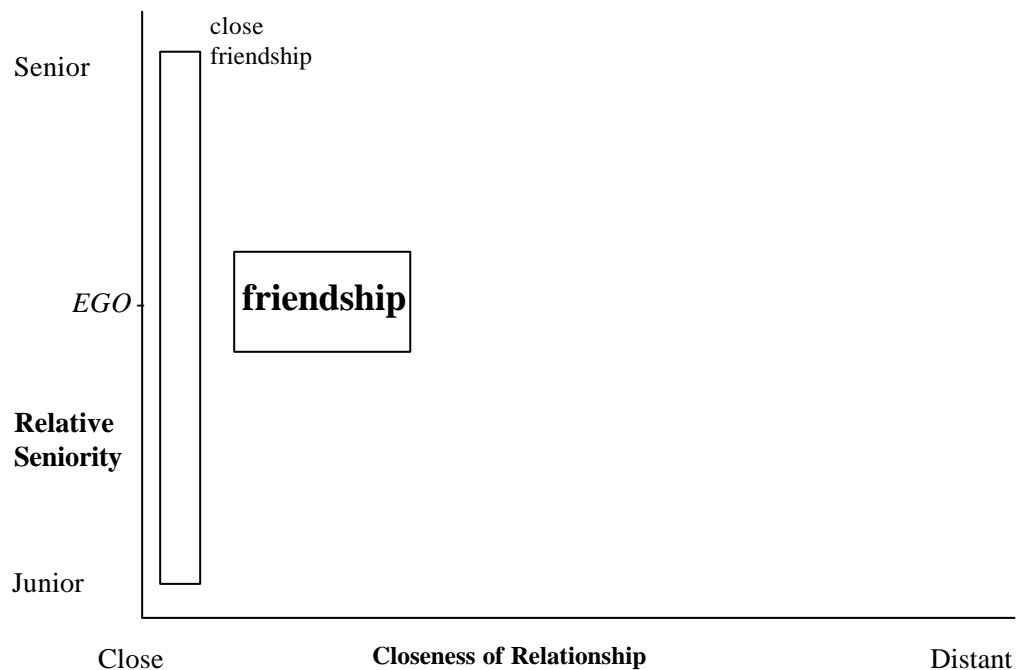

Figure 3. 4. *Friendship*

(Author’s diagram)

Friendship therefore is essentially a relationship between peers. There seems to be a popular perception, played out all too often in the media, that a close informal relationship across significant steps in rank is not possible in the Army. The following sub section will demonstrate that this is a false perception.

Association

Where two soldiers separated by rank distance wide enough to exclude *friendship* between them come into regular and frequent contact they will often form an informal bond of mutual trust and respect. This bond falls short of *friendship* as defined above, but is nevertheless a strong informal relationship. I have called this relationship ‘*association*’.

The nature of this relationship is illustrated in the following four extracts from my field notes:

A warrant officer, of the relationship between the sub unit commander and his sergeant major, “They like each other and they work closely together...”⁴²

An officer, of his chief clerk from a previous posting, “We had established a warm relationship ..., sharing jokes and views on politics, as well as forming a good professional working arrangement. In a particular time of distress for my family he had even offered me a small amount of moral support in private.”⁴³

A subaltern about life in his sub unit, “The good thing ... is that the seniors [senior NCOs] and officers can form quite close knit relationships, and so they do talk, not really as a Staff Sergeant to an Officer but sometimes as a - though it’s never friendly - friendly chat.”⁴⁴

‘He said that a troop sergeant and his corporals would go out drinking together, but there was still a bit of distance between them - a corporal wouldn’t ring up the sergeant and say “are you going out in the piss tonight?”’⁴⁵

It is a mixture of closeness and distance: closeness in terms of the mutual trust respect and affection, and in the flow of information and relaxed conversation between the parties, and distance in terms of an underlying expectation of deference by the junior partner when it is required by the senior one. In essence it has many features of a warm and close client/patron relationship.

Bonds of *association* may superficially resemble *friendship* in many ways, but the relationship is not the same. Although the two individuals concerned may get to know each other very well, spend a great deal of time in each other’s company, get to develop trust in each other, and can even criticise each other without damaging their relationship, it is likely to have a substantial professional element: its primary context is the arena of work. As a

particular example, a sub unit commander is more than likely to form a strong bond of *association* with his sergeant major so that each grows to know how the other thinks, and so that no professionally important subject is a forbidden matter of discussion between them. Indeed, a sub unit sergeant major is the only person within the sub unit who is accepted to have the right to tell the officer commanding that sub unit that he is making a mess of things - though he should only do so in private. However, it is extremely unlikely that they will choose to spend much of their spare time in each other's company.

Like *friendship*, *association* has structurally defined limits. The most significant ones are:

- First, the obvious one that it is only likely to arise between people who come in close regular contact with each other at work.

- Second, within its context, *association* can only be formed between two people whose structural positions are directly connected in some way. Thus, a company commander will form an *association* with his sergeant major, but probably not with corporals from another company. However, it should be noted that there are a variety of contexts in which the conditions for *association* can arise, and that individuals can form *association* in several of them in different contexts at the same time. For example, a battery commander might well form *associations* with his battery commander's assistant (usually a sergeant) in the context of exercises and operations, and with his driver (usually a private soldier or a lance bombardier) in the context of long road journeys, as well as with his battery sergeant major in the more general context of the life of his battery.

Because the pattern of the bonds of *association* are so dependent on the context, they vary observably between units with different organisational structures and roles. Whilst, for example, it is likely that any commanding officer will be in a relationship of *association* with his regimental sergeant major, at lower levels there is a different pattern of *association* between members, say, of an Army Air Corps unit and an infantry unit. Specifically, in this instance, there is no equivalent pattern in an infantry battalion of the bonds of *association* that exist between aircrew of significantly different ranks.

In exploring the limits of *association*, I discovered that a very reasonable test was the matter of family holidays. Whilst it is reasonable for *friends* to take family holidays together, at no stage, for example, did any officer or senior NCO say during an interview that those linked by even the closest bond of *association* would be likely to choose to do so. This was highlighted in a conversation between myself and a colleague who had heard me present my model at a seminar. He told

me that I was wrong in saying that *friendship* could not be formed across wide rank gaps. When he commanded his regiment, he told me, he got on so well with his driver (a junior NCO) and spent so much time with him that he considered him his ‘friend’. He could not be shaken in this view until I asked him if he had ever considered having him along on a family holiday. “Certainly not!” he replied, after which he agreed that the relationship was probably a very close form of *association* rather than *friendship*.⁴⁶

It is worth noting here that it is widely recognized in the Army that the relationship that I have called *association* provides an important vehicle for an experienced NCO to pass his experience on to an inexperienced young officer. This is exemplified in the statement by a Royal Armoured Corps officer that “It is the Troop Sergeant’s responsibility to train the young officer”⁴⁷.

Like *friendship*, *association* can be revived after a lapse of time. It is not uncommon, for example, for a Commanding Officer to choose as his RSM the man who was his sub unit sergeant major when he was a sub unit commander.

The position of *association* in the model is shown in Figure 3. 5:

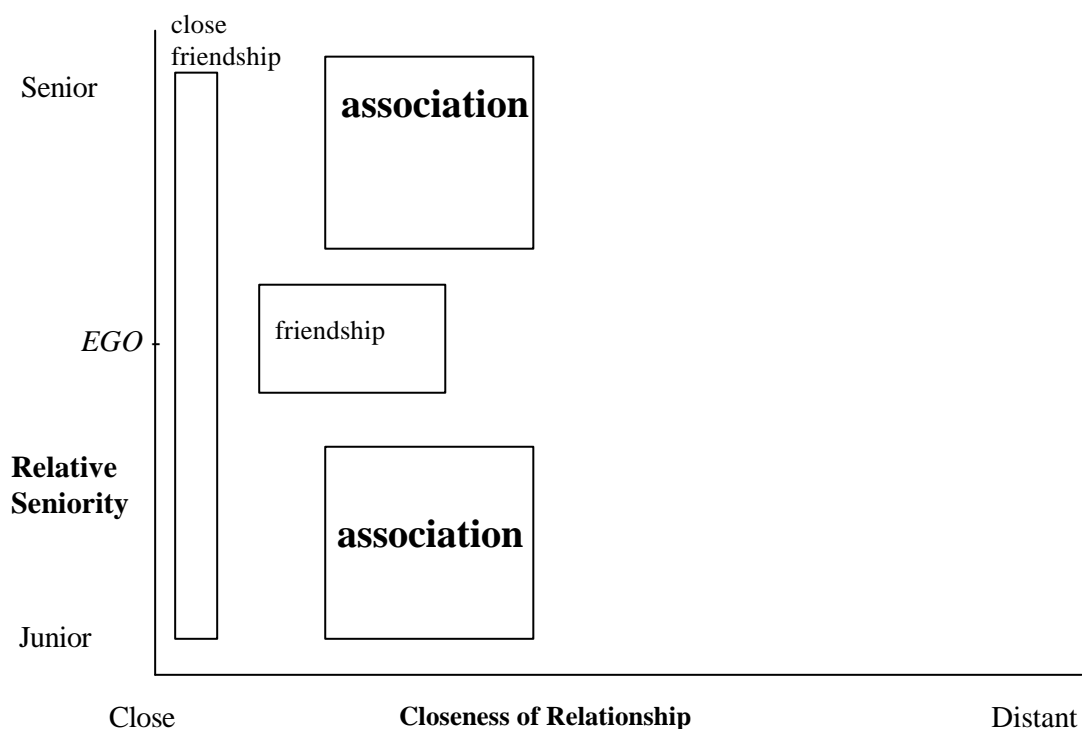

Figure 3. 5. Association

(Author’s diagram)

Informal Access

It is recognized, though not officially laid down, that each individual has a right to speak informally and without a formal appointment with certain other people who are at a degree of

rank distance (superiors in his chain of command for instance), even though a link of *association* does not exist between them. Thus a newly joined junior officer can expect to be able to have *informal access* to his sub unit commander, as the sub unit commander can to even the most reserved and unfriendly Commanding Officer. Similarly, any member of a sergeants' mess can expect to have opportunities informally to approach the RSM.

Informal access therefore allows informal contact between people who are structurally widely separated, either by rank or by position in the unit. It is a distant relationship in that it resembles more a client/patron state of affairs than the fellowship of equals, but it is nevertheless an important element in the *informal structure* because it allows informal contact across lines over which other informal relationships will not stretch. This, for example, is an extract from notes from an interview with a RSM:

'Although he likes to keep a certain amount of structural distance between him and the soldiers, he needs to keep in touch with them. He does this by direct contact with the private soldiers and through the CSMs [company sergeant majors] and so on. He does not think of himself as in an unapproachable position. "I would still have now [private soldiers] come and see me and although I'll listen to them, I'll tell them when I've heard them to go through the correct chain of command." These are soldiers who knew him personally as a company sergeant major or as a platoon sergeant.'⁴⁸

Here a captain speaks of informal conversations with his soldiers when he was a platoon commander a few years earlier:

"But on the one to one level it's probably, you know, when you're popping round the platoon harbour [temporary base] and find the guy on sentry and you'll sit there and chat with him and keep your eye on the trees [i.e. seeking to avoid eye contact to make the situation more informal]. I always used to hold platoon interviews, and there were plenty of characters who were quite prepared to come out and tell me what was going on but there were some who I would only know I could talk to and hope to get anything out of on an exercise when they were on their own and it wasn't an interview-type situation. It was a sit down and shoot the breeze while sharing a cup of tea or something [situation]."⁴⁹

Although this relationship is manifestly cooler than those we have considered so far, it is a means for the construction of important personal bridges within the unit. For example,

- It provides the necessary vehicle for the Commanding Officer to remain in personal touch with those of his officers with whom he has not established a bond of *association*.

- It similarly provides the RSM with the means to form a reserved but informal relationship with the members of his sergeants mess which allow them to approach him without formal appointment.

- Where, as is usual, the relationship between a sub unit commander and his officers is likely to fall short of *friendship*, and where no *association* exists between them, then they will almost always have a relationship of *informal access*⁵⁰.

- Any sergeant can expect to be able to have *informal access* to his sub unit commander.

- Any private soldier can expect to have *informal access* to his troop or platoon sergeant and his troop or platoon commander, and vice versa, as we saw in the captain's remarks above.

- A young officer can use this relationship informally to approach influential people outside his chain of command where *friendship* does not exist between them. For example, from my personal experience, when I was a comparatively newly-arrived second lieutenant and the food member of an officers' mess⁵¹ it provided the mechanism to allow me unofficially to approach the unit quartermaster. I needed to approach him because my food account was in the red and he was in the best position to help me to get it out of debt without making its parlous state fully official. However, my approach to him was made difficult because he was a formidable man who had no liking for young officers and I knew that he would be unsympathetic. In that case the relationship of *informal access* existed because we both had common membership of the officers' mess, but the quartermaster's hostile attitude excluded *friendship* or *association*.⁵²

As with the other informal relationships, there are structural boundaries to this element in the *informal structure*:

- Like *association*, *informal access* only exists between people who come into regular contact.

- There are rank limits beyond which this relationship will not usually go. For example, few private soldiers are likely to have *informal access* to their sub unit commander⁵³, and, it would be comparatively rare for a subaltern to gain *informal access* to his Commanding Officer.

- In most cases the relationship will follow the lines of the *formal command structure*, in that it would not be normal for a private soldier in one platoon to have *informal access* to the commander of any other platoon. However, exceptions can arise, but only where there is obvious common ground between the parties, a shared function or common professional interests for instance.

- The subject matter for conversation in *informal access* relationships is also constrained. While the junior party may seek to air his own personal affairs, the senior one will not. For instance, a soldier may use his relationship of *informal access* to tell his troop sergeant about some unfortunate family fact as background to a possible bid for compassionate leave in the future: the sergeant would be unlikely to reciprocate with details about his own marriage. Similarly, there would be no question of criticism passing from the junior to the senior in this relationship.

Figure 3. 6 places *informal access* in the model.

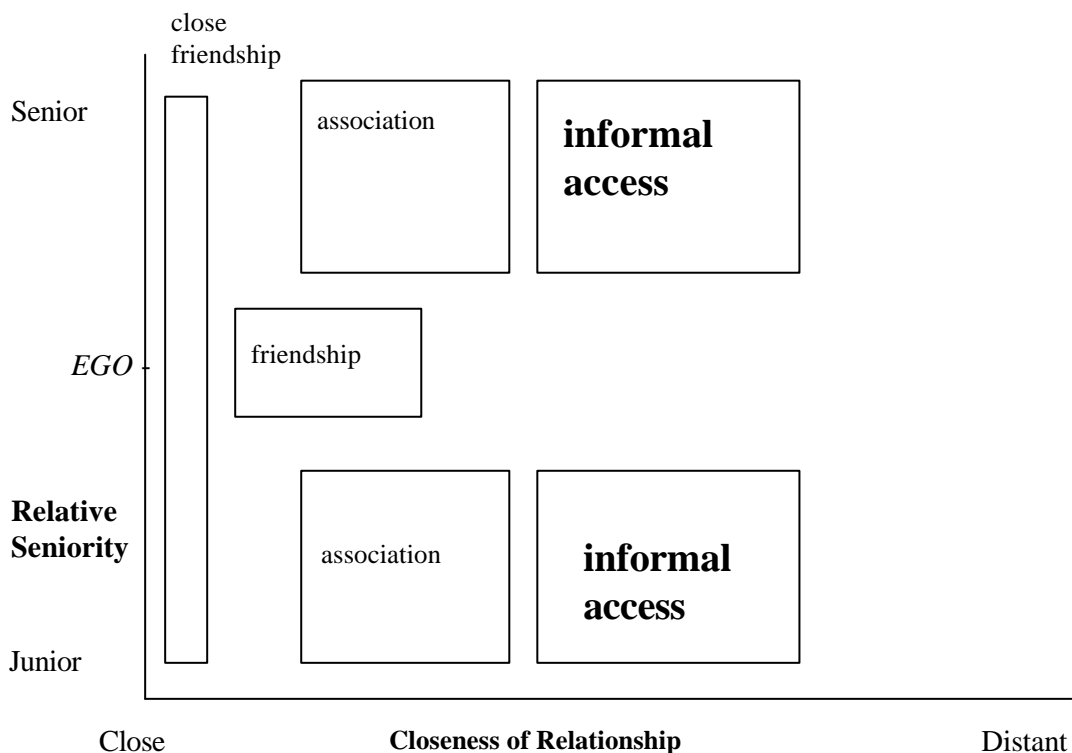

Figure 3. 6. Informal Access

(Author's diagram)

Nodding Acquaintance

The most distant informal relationship that completes the typology of relationships is *nodding acquaintance*. Here, the parties to the relationship know each other by sight, but not necessarily by name. They know something about each other, and both acknowledge that they belong to the same organisation (at whatever level is appropriate) but no other informal relationship exists between them. As one soldier said in an interview, “You generally nod at him because you’re on the same side.”⁵⁴

An important aspect of *nodding acquaintance* is that there is always the potential for a closer relationship to develop between the parties when the right conditions arise. Whilst there is no inevitability that the relationship will grow closer, it can be considered to be a closer relationship in waiting. This is illustrated by the following two examples:

One soldier told during an interview how while he was away on a Northern Ireland tour his wife and another man’s wife got to know each other very well, “got themselves both through the tour together” and became very close; he hardly knew the husband of the wife’s new friend, but “when we came back ... I started to know him more, and now I’ll say that ... he’s probably one of my two or three really close friends.”⁵⁵

On the other hand, in another interview a regimental quartermaster of nearly 30 years service regretted the fact that now many of the junior members of his unit were known only to him by sight. He might greet them in passing and have a brief word with them, but he did not know them at all.⁵⁶

In the first example, the *nodding acquaintance* led to a *close friendship*, but in the second the relationships remained at the *nodding acquaintance* level.

Nodding acquaintance is now added to complete the model in Figure 3. 7.

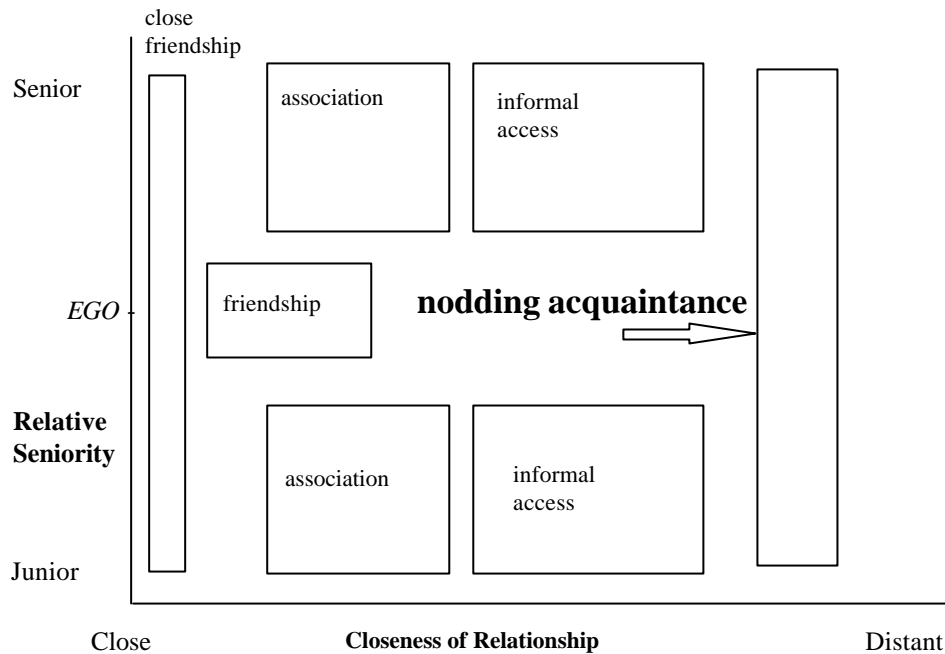

Figure 3. 7. Nodding Acquaintance

(Author's diagram)

Comments

Given the great variety in human relationships, it may seem counter-intuitive to model soldiers' relationships with only five categories. However, it is to be remembered that each of the boxes in the diagram has a horizontal dimension which corresponds to various degrees of closeness on the horizontal axis of the diagram. On the principle that a line consists of a very large number of points, there are a very large number of places along each line where the closeness of a particular relationship might fall. This gives a range of closeness or distance in any of the relationships which allows for a high degree of variety. Relationships of *association*, say, can vary from the more distant - barely beyond *informal access* - to a degree of closeness that considerably overlaps the closeness of *friendship*. However, it never reaches the depth of the more intense friendships and never approaches *close friendship*. Similarly, a soldier will like some of his *friends* more than others, and will find *informal access* easier with some people than others.

Some of those who have seen and commented on this diagram have been distracted by the gaps between the boxes. Most of these gaps have no significance apart from separating the boxes on the page to make the model readable. The one gap that has genuine significance is that between *nodding acquaintance* and *friendship* which signifies that a relationship between peers will be either one or the other: there is no hinterland in the way that *informal access* comes naturally between *nodding acquaintance* and *association*. Once peers have got to know each other then there is an expectation that they will form *friendship*, albeit for some parties the relationship will not grow particularly warm.

Another important consideration here is agency, as discussed in Chapter One.⁵⁷ It is perfectly possible for two individual agents in an informal relationship to experience, and thus to view, the relationship in different ways. A clear example is that it is easy for a person of superior rank to assume, and therefore to have, *informal access* to his subordinates whilst the subordinates would not necessarily have the same relationship with him: a company commander might go to see any of his private soldiers at whim, for example, during the working day but the company sergeant major would probably arrange things so that the privates may not call upon him without making an appointment. In other cases, an individual might perceive a relationship with a peer to be a close form of *friendship* whereas the other party may consider the relationship to be less close.

The lack of an allowance for individual agency should be recognised as a limit to the model, and this limitation should be borne in mind when using it to examine individual cases in detail. However, this is a comparatively minor deficiency in considering either a number of cases or in examining general trends and making general predictions.

Rather than dwelling on any real or assumed lack of precision in this diagram, it is better to concentrate on its power as an analytical tool in considering informal relationships between soldiers, as will be demonstrated in Chapter Four.

Limits to enmity

Although informal relationships within a unit of the combat arms are generally positive and mutually bonding, not all are so: mutual dislikes also occur. Apart from providing a structured suite of relationships, therefore, the *informal structure* contains elements that address personal enmity.

All those interviewed on the subject agreed that there were certain people whom one might dislike, but with whom open animosity was not sustainable. In particular, there was a limit to the degree to which those in close proximity (either physical or structural) could openly fall out. For example, for private soldiers who lived in barracks, there were social pressures which meant that those in the same room could not fall out for long, and neither could those in adjacent rooms (who are usually within the same troop or platoon). While arguments and possibly the odd blow might be exchanged, virtually no quarrel lasted for very long, the control mechanism being usually provided by the other soldiers in the same context (same room or same troop/platoon). An infantry corporal summed up the situation concisely:

“You can’t have a grudge between individuals in a barrack room. You go round the back and have it out, or you sort it out under the Junior NCOs.”⁵⁸

He added later in the same interview that fights, if they occur, must be in private and in the open air (outside the building). However, he had not seen this sort of thing for a long while.

As another example, in a different interview an infantry soldier told me,

“ ... it’s never ... the people you’re living with. It’s very rare that you have a fight with anybody that you’re actually staying in a room with. ... Very rare. Most of the time it would be somebody outwith your platoon.”⁵⁹

A similar message came from an interview with a Royal Armoured Corps warrant officer when I asked him about fighting in the accommodation block. He told me that soldiers naturally keep apart if they dislike each other and there are usually people prepared to break up fights within the accommodation, “Nine times out of ten there is a more sensible person there, for example, a senior soldier.”⁶⁰

In a tiny minority of cases the mutual dislike of the parties exceeds the capacity of these control mechanisms. In such cases, it is usual for the soldiers’ superiors to arrange a posting for one of them, either out of the sub unit or out of the unit altogether, which effectively suspends the quarrel.

Within the sergeants’ mess, mutual hostility is usually constrained by the disapproval of the RSM and the consequent actions of the disputants’ peers to stop them exchanging blows.

A RSM: “I’ve got to say I have never... I’ve... never seen a fight in the mess in my time. There may have been words said but it’s a case even then of saying ‘Right! Stop! [as if addressing the WO2s in turn] Company Sergeant Major! Company Sergeant Major! You leave.’ or whatever it may be.”⁶¹

Similarly, among the officers there is a degree of mutual animosity that is considered unacceptable and any potentially explosive situation will normally be constrained from getting out of hand by the peers of those involved.

Although informal relationships are one of the key expressions of the *informal structure*, there are many other such expressions. The rest of this section explores selected examples that are prominent features in the informal life of a unit.

Other selected facets of the *informal structure*

We now turn to the six other areas which I have selected as important manifestations of the *informal structure*.

The formation of informal groups

Informal groups among private soldiers and junior NCOs will primarily be formed on the basis of *friendship* and thus do not contain a significant spread of ranks. Thus a single private soldier will choose to eat his meals or go out drinking (perhaps the most informal of group activities) with people with whom he is *friends*, or with whom he wants to build a *friendship*, and this means that for the most part they will probably come from his troop or platoon or at least his sub unit.

Groups in the informal surroundings of the officers' or sergeants' mess will similarly tend to fall within the structural bounds of *friendship*: the subalterns of a unit may well form a group, and so may the captains (perhaps with a senior subaltern or two included), but it will be rare for an informal group to include subalterns, captains, and majors because that exceeds the structural limits of the relationship of *friendship*.

Structural position and the process of time

Although informal relationships (especially *friendship*) seem at first sight to be determined in large measure by individual taste and mutual compatibility, they change as the individual's position in a unit changes with time. The relationships in the *informal structure* therefore have a dynamic and flexible quality.

Those who join a unit together from training usually tend to form identifiable groups at first (regardless of their dispersion over different sub units), but these groups fall apart as the individuals settle into their new sub units. This extract from my fieldnotes shows how I recorded a private soldier's view of his arrival at his artillery unit from recruit training.

'His period of induction was made easier for him because he had eight friends from training and they stuck together for the first week and a half, after which they started to make friends with other people, "losing touch" a little bit with those people from training who were in different troops, and much more so with the one who went to a different battery.

Comment: A good description of the process, reflected in other interviews. Friends formed in the priority: troop, then battery, with very few father afield. Initial friendships withered as structurally closer friendships took their place.

Analysis: The newly-arrived soldiers imported their existing bonds of *friendship* from training into the battalion, but more structurally appropriate *friendships* arose as they settle in.'⁶²

Promotion also causes changes in informal relationships. Although at the most junior end of the scale it does not make much difference to the individual's relationships with those who were his peers, increasing responsibility starts to limit his freedom of action. As one lance corporal put it,

'You can't try and skive, you can't take the mickey out of other NCOs in front of the lads, and you must knuckle down to work, but promotion made no difference to friendship.'⁶³

However, as people become divided by rank and some get promoted faster than others, so their relationships usually have to change,

'... he found the promotion to corporal was the most difficult. There were senior [private soldiers] who dropped him as a friend. He hated this, and it made him very pleased to leave [the unit on posting] when the time came.'⁶⁴

Summary of information from a sergeant: 'When he and the current RSM joined together [as private soldiers] they were on first name terms, naturally. When the RSM came back from the Depot as a lance sergeant, their paths did not cross sufficiently for their mutual terms of address to be identifiable. Now he is the RSM, he calls him "Sir". The only exception is on the sports field, "He's actually played football for the battalion as well. During training and during the match I've called him 'Bill'." But if he met him in the street, it would be "Sir" - so football is the only context in which he would use his first name.'⁶⁵

We saw an extreme example on page 96 of formal disapproval in the case of the newly promoted sergeant who lost his rank because he went into the Corporal's Mess, but the need to put one's former *friends* at a distance on promotion to sergeant is a well recognized element in unit life.

Another illustration of the dynamic nature of the *informal structure* is provided by the post of Adjutant (the Commanding Officer's personal staff officer). Typically, a Commanding Officer will choose as Adjutant one of the captains already in his unit, and one that he already knows. The captain concerned will usually hold the post for somewhere between a year and 18 months, during which his informal relationships undergo a detectable change. Although he will still retain his *close friends*, a degree of distance is likely to grow into his relationships of *friendship* with his fellow captains and the senior subalterns, while an increasingly warm relationship of *association* will grow between him and his Commanding Officer. It is unlikely that he will form any *friendship* with the younger subalterns: indeed, in some units a degree of structural distance between him and the subalterns will be formalised in a rule that they all have to address him as "Sir" (no other captain would be addressed as such by any officer). However, if he is not posted or promoted at the end of his period as

Adjutant then he will become just another of the unit's captains, and be able to revive his old informal relationships and form appropriate new ones.

Informal hierarchies: the pecking order

We have already noted that informal groups are primarily formed between individuals who fall into the category of potential *friends* and therefore there is an insignificant spread of ranks between them. Although the *informal structure* is by its very nature not formally stratified, there can nevertheless be distinctive levels of seniority within these informal groups of peers, or near peers. These levels of seniority are best expressed as a hierarchy of influence and prestige (and often privilege), within informal groups without direct reference to formal authority. To distinguish them from the rank system of the *formal command structure*, I have chosen to use the term *pecking order*.

The majority of the private soldiers interviewed described versions of the *pecking order* in the informal surroundings of their troop or platoon living-in accommodation. An example of this mechanism operating is the early morning cleaning task or 'block job'. In many units where this is still done⁶⁶ the most junior soldiers have to do the really unpleasant tasks (cleaning the lavatories seemed to be most commonly the province of the lowest member) while the more senior ones graduate to what might amount to no more than a little light dusting.

'An infantry private, in response to my question, "What about block jobs?", "Normally it goes up in seniority. The more senior guys get the easier ones. ... When you get to the top and you become the senior, there's no more room jobs. You come off and then you monitor the room jobs. You'll be in charge of five or six room jobs."' ⁶⁷

"Somebody that's been in a long while will maybe brush the corridor and all the new guys who come in always get landed with the toilets." ⁶⁸

'If an officer gave a senior soldier a dirty job to do, that soldier 'would probably end up palming it off to the newer guys'.' ⁶⁹

As these three extracts from my fieldnotes indicate, a highly significant factor in ranking in the *pecking order* amongst private soldiers is length of service. Thus only those who are newly arrived from training find themselves right at the bottom, and the 'senior soldiers' of longer standing are likely to be at the top. The power and prestige of a senior soldier amongst his fellows can become almost institutionalised. Such soldiers are 'guardians of standards' in the unit ⁷⁰.

There, are, however natural variations on this pattern. First of all, an important ranking factor in the *pecking order* can be force of personality, which can occasionally overcome the primacy of length of service. A second, demonstrated by Killworth⁷¹, is the ability to perform well at military functions rated as important by an individual's peers. Thus it can happen that the soldier without a strong personality or one with poor military skills never attains the level in the *pecking order* to which he might otherwise be entitled by length of service. Such men were informally called 'rejects' in one unit that I visited. It was noticed by one of the interviewees in that unit that these men tended to be friendly to newcomers, who could be presumed to be ignorant of their weak position as 'rejects'.

'The people who keep talking to you [whilst you are new] are the ones you should stay clear of. They are either the bad lads who are going to get you into trouble or borrow money off you - or they are the rejects, "it's easy to talk to a Crow [unit jargon for a soldier fresh from recruit training], like". ... A senior soldier took him under his wing and pinpointed who to talk to and who not to. ...

I asked about the rejects - did they not become senior soldiers? How could he tell the difference? He said the no one stays where they're not wanted, so the rejects don't tend to get to be senior soldiers in rifle companies.'⁷²

Another private soldier in a Scottish battalion summed up this situation in another way: "... if you get an idiot staying in for nine years you'll never call him a 'senior jock'."⁷³

The *pecking order* is not confined to private soldiers and junior NCOs. However, in sergeants' and officers' messes there is more potential for variety because in both fora there is the extra factor of rank.

An infantry subaltern, in answer to my question, "It is there a pecking order in the Officers' Mess?" said,

"Yes, very much so. It's like, really, the Sixth Form, I suppose. The prefects - the more senior captains.... To start at the bottom you have the newest guys, and then people like myself who have been there for a little bit: they're allowed to speak and talk. And then you've got the senior captains, the captains and the senior captains, who generally run the show up there. And then we've only got one major living in at the moment, who's called sort of 'Grandfather of the Mess', but he's a mega bloke and someone you can talk to."

Analysis. A *pecking order* based on experience and time in the Service. The senior major has a relationship of *association* with the junior subalterns.⁷⁴

Rank can be the primary determining factor: thus, for example, one ex-RSM described how throughout his time in his mess (over 15 years) at lunch times and in the evenings the sergeant majors always stood in a group at the bar, while the rest sat at tables

and approached the bar only when they needed to order a drink.⁷⁵ In another unit the primacy of the sergeant majors in the mess *pecking order* was recognized by their exclusive entitlement to a part of the ante room during coffee break in the morning.⁷⁶ In a similar way, in most officers messes the best bedrooms are allocated to the more senior single officers by rank, and a junior one may well have to move to a less sought-after room if a more senior one arrives. However, length of service can still be an important factor: for instance, in a particular Royal Artillery officers' mess access to scarce resources (a garage, and extra furniture for the officer's room) was allocated with time in the regiment as the only determining factor.⁷⁷

Killworth has disputed this concept of the *pecking order*, having read the description in my defence fellowship thesis, which is essentially an earlier and more compressed version of what appears here⁷⁸,

‘I suggest that there are two key difficulties with the construction of the pecking order. Firstly, it separates or reifies an order from what are, on the ground, a morass of interwoven social situations. ... Secondly, by restricting the model to private soldiers, Kirke follows Hockey in artificially separating common ideas about hierarchies and prestige held by both private soldiers and NCOs.’⁷⁹

Such a clear critique of my concept deserves a reply.

His second point, that I restricted the model to private soldiers, is simply incorrect, as the concept of a *pecking order* in both sergeants' and officers' messes was considered there, as it has been here. However, his first point is worthy of further examination.

The observation that the concept ‘reifies an order from what are, on the ground, a morass of interwoven social situations’ is a criticism that can be levelled at any social model if that model is mistakenly given the status of a scientifically complete description of facts. In this case, as in the whole of this thesis, what is presented here is not an attempt to put forward an established set of facts, but a model that is useful in the description and analysis of observed situations and contexts (Killworth's ‘morass of interwoven social situations’) and which can have a predictive power in examining future contexts.

I am, however, indebted to Killworth for highlighting the fact that the ability to perform military skills well is an important ingredient of the prestige system, a point missing from my defence fellowship thesis which gave particular emphasis to the importance of length of service and personality. This omission has been rectified above.

There is also an important methodological point of difference between Killworth's work and mine, which may well have caused him to view parts of my work in a critical light. In observing soldiers, especially at junior NCO level and below, discussing and disputing the

prestige of individuals⁸⁰ his attention was drawn to the process in which prestige was manipulated. My analysis from very similar observations was more focused on the existence of an informal prestige system between soldiers who are peers (or near peers) and I concluded that such a system should be a necessary component in a model of the *informal structure*. Our observations and conclusions are therefore complementary, rather than opposed.

Killworth's further argument that the *pecking order* is a manifestation of a wider system of prestige⁸¹ integrates with a point that will be examined later as a background ingredient to the model. This background ingredient is the idea, present in most soldiers' minds for a very large proportion of their service, that there is a hierarchy of superiority and inferiority in all contexts.

Terms of address

When the *informal structure* is the *operating structure*, terms of address give an important indication of the relationship between individuals, and there are clearly distinguishable patterns.

Those in a relationship of *close friendship* or *friendship* invariably address each other by their first name or by a nickname acceptable to both parties.

For *association* and *informal access*, on the other hand, the usual patterns vary with the various ranks and appointments involved. Both kinds of relationships are by their nature asymmetrical in rank and the terms of address reflect this imbalance. Where one party is a commissioned officer and the other is not, the officer will normally be addressed as "Sir" (sometimes "Boss" as a deliberately informal alternative to "Sir") while the junior will normally be addressed by his rank or, with certain appointments in the unit, by his appointment or a derivative of it. Thus a conversation reflecting *informal access* between a company commander and one of his platoon sergeants will include "Sergeant (coupled with the sergeant's surname)", or the slightly less formal "Sar'nt", and "Sir". Similarly, the modes of address between the unit Chief Clerk and the Adjutant (who are typically in a relationship of *association*) are likely to be "Sir" and "Chief".

Where both parties are commissioned officers, there is further variety, but still within a discernible pattern. Officers of the same rank will be on first name terms, and all subalterns and captains will be on first name terms. It will be normal for junior officers to address their sub unit commander either by his first name or as "Sir" (the choice depends on the custom of the unit and sometimes the personal tastes of the Commanding Officer at the time). The Commanding Officer is normally addressed as "Colonel" by all but the most junior of his officers, who call him "Sir" (there are certain exceptions: for example, all the officers in Foot

Guards battalions usually call their Commanding Officer “Sir”). However, in all cases, the junior of the two parties is addressed by his first name, or (less usually) by a nickname.

Where neither party is a commissioned officer, context is a significant factor. When senior members of the sub unit or unit (often called ‘the hierarchy’ or ‘the management’) are present (for example, the sub unit commander, his sergeant major or the Commanding Officer) it is normal for the junior to be called by his first name or by his nickname and for the senior one to be called by his rank or by its diminutive (“Bomb”, “Corp”, “Sarge”, “Colour”, “Staff”⁸²) where it is below warrant officer, and “Sir” if he is a warrant officer. However, when ‘the hierarchy’ are not present, private soldiers will call junior NCOs by first name or nickname and sergeants will quite often allow their first names or nicknames to be used. The right of a junior to call a sergeant by his first name results from a process of negotiation between the two. Sergeants in interviews claimed that they set the rules and gave permission for their first names to be used. One sergeant, indeed, made a point of saying that he deliberately used this as a leadership tool, bestowing it as a reward for good team work and withdrawing it if things did not go well.⁸³ However, a minority of private soldiers said that they “tried it on” with their sergeants by using their first name or nickname without permission and, when successful, established the right to use it regularly.

The terms of address for *nodding acquaintance* also vary with the relative ranks of those involved. Among commissioned officers the terms of address appropriate for *informal access* will be used, with the proviso that, in units where young officers are expected to graduate from the respectful “Sir” to first name terms when addressing majors, a subaltern is more likely to use “Sir” to a major before forming a closer relationship with him. Fellow members of the sergeants mess will probably adopt the terms of address appropriate to *association* and *informal access*. A sergeant is likely to be addressed by his rank by all *nodding acquaintances* junior to him, whereas it is less likely that a junior NCO will insist on his rank being used, even by *nodding acquaintances* unless the context calls for it. Private soldiers will be on first name terms with *nodding acquaintances* who are private soldiers, but may not allow the use of their nickname.

There remains one further ‘term of address’, which regularly emerged during interviews, where one or both parties simply speaks to the other without using a term of address at all. The majority of occasions where this circumstance occurred seemed to be connected with ambiguous states where the *operating structure* was either not certain or was in the process of changing. For example, it might occur where a sergeant and a private soldier have been speaking on first name terms and a member of ‘the hierarchy’ intrudes onto the scene, or when a warrant officer meets a private soldier unexpectedly outside the military context.

‘Underlife’

In *Asylums*, his examination of life in public institutions, Goffman devotes a long essay to what he calls the ‘underlife’⁸⁴, or the ways in which the members of the institution adjust their behaviour to enhance their ability to thrive or, in oppressive contexts, survive as comfortably as possible. He investigated the operation of informal structures in formally structured organisations (for example armed forces, prisons, mental hospitals, boarding schools and religious institutions, mostly in the Anglo Saxon tradition of the USA and Great Britain), and so his work provides many insights that are relevant to this thesis.

Describing the way that an individual adjusts to life in what he calls ‘total institutions’⁸⁵, he makes a significant distinction between ‘primary’ and ‘secondary’ adjustments⁸⁶. Primary adjustments consist in the cooperation of the individual in what the institution requires, whereas secondary adjustments belong to the informal world: they ‘represent ways in which the individual stands apart from the role and the self that were taken for granted for him by the institution’⁸⁷. This concept of ‘adjustments’ maps well into the model of social structures in that primary adjustments would represent adaptations to the formal *command structure*, whereas secondary adjustments would belong to the *informal structure*. Goffman further makes a distinction between ‘disruptive’ secondary adjustments, which are aimed at rupturing the smooth running of the organisation, and ‘contained’ secondary adjustments, which fit into existing institutional structures without introducing pressures for radical change⁸⁸.

The vast majority of secondary adjustments in the Army are ‘contained’ in that they do not introduce pressures for radical change. However, to develop Goffman’s model, ‘contained secondary adjustments’ can be further subdivided, at least in the British Army.

There is an observable division of secondary adjustments into what are seen by those practising them as the sort which add to the smooth running of life in the unit and attract little or no formal disapproval, and those that are expressly forbidden and will be punished if discovered. I have called the former *legitimate secondary adjustments*, and the latter *illegitimate secondary adjustments*.

The range and extent of secondary adjustments in the field of study are so great that it is impossible in the space available to give a comprehensive account of them. However, it should be understood that *legitimate secondary adjustments* are an all-pervasive aspect of life in a combat arms unit, and that opportunities for *illegitimate secondary adjustments* are permanently in the offing for most soldiers. The limited number of examples given here will have to suffice to give an insight into the whole.

The following are examples of *legitimate secondary adjustments*:

- ‘Contacts’. There are certain formally approved ways of getting things done in a military unit, but it is often more effective for the individual if he exploits an existing informal relationship to achieve his end. As a single example from a vast field, one private soldier said in an interview that if he felt he needed to go on leave at a time when it was inconvenient for his company’s programme of commitments he would approach his company sergeant major direct. According to the formal rules, he first should make his bid to his platoon sergeant, who would consider the matter and pass it upwards to his sergeant major. It transpired that the soldier and the sergeant major were both in the battalion football team and that a relationship of *association* existed between them (which would guarantee a sympathetic hearing), whereas he only had a relationship of *informal access* with his platoon sergeant.⁸⁹

- ‘Favours’. It is accepted that anyone doing a favour for another person in the line of business can expect the favour to be reciprocated in due course. This is summed up in the often-used phrase “I owe you one for that!”. Such exchange of favours is typical, for example, of agreements between sub unit sergeant majors to help each other with covering inconvenient manpower commitments such as camp guards or the provision of transport at a difficult time.

- ‘Buckshees’⁹⁰. Virtually every NCO who runs a military store has equipment surplus to his ledger, known as ‘buckshees’. This is despite the fact that such surpluses are discouraged and periodic inspections are carried out by those in authority to identify and eliminate them. Such equipment is known as ‘buckshee’. When he finds that he has a shortage against his ledger the NCO will use his informal relationships (his ‘contacts’) to set up an exchange with another NCO who has a surplus of the item he needs, giving an appropriate ‘buckshee’ item in exchange. Should the situation arise where the man with the ‘buckshee’ does not have a shortage, he may still give up the item to someone who needs it, but then the transaction becomes a ‘favour’.

Examples of *illegitimate secondary adjustments* include several activities identified by Hockey as what he calls the ‘informal’ or ‘unofficial’ aspects of a certain infantry battalion⁹¹. He identifies a number of practices which he calls ‘deviant’, which, in the terms of my model, amount to secondary adjustments that attract active disapproval within the *formal command structure* and are thus ‘illegitimate’. Examples are ‘skiving’ (avoiding work), ‘scrounging’ (appropriating unmarked personal military equipment), and ‘shortcuts’

(such as using destructive acidic abrasives to clean weapons more easily), which may make life easier for the individual but are against the rules. Hockey also notes that private soldiers have the power to undermine the career of their superiors by under-performing their military tasks⁹², a process which might be called ‘passive revenge’.

Other important types of *illegitimate secondary adjustment*, identified in the course of the research for this thesis are:

- *Active revenge*⁹³. Sometimes a group of soldiers will become so infuriated with a particular superior that they will actively take measures against him. These measures usually take the form of making his life difficult, embarrassing or uncomfortable without risking formal punishment. For example, two soldiers who were fed up with their sergeant’s idleness on exercise ate all his rations one night: “He was asleep at the time and so me and the other lad, the runner, we ate that scoff just out of sheer spite: we felt ‘Sod it!’. We were nearly sick.”⁹⁴ Again, one highly unpopular officer discovered while on exercise in Canada that he had lost his pistol (a very serious military offence). It transpired that some members of his vehicle crew had buried it somewhere on the prairie, but as they subsequently (anonymously) exhumed it no disciplinary action was taken.⁹⁵ It is noteworthy that very little lasting damage is done during these episodes of active revenge, in spite of the opportunities that present themselves. As one soldier remarked during an interview, the purpose of such acts is to convey the warning “We don’t like you” rather than to carry out vindictive action for its own sake⁹⁶. It is hard to gauge the frequency with which this sort of *secondary adjustment* takes place. I concluded that it was not commonplace, but I noted that in every unit where the subject was raised at least one interviewee had an eye-witness story to tell on the subject.

- *Fun*. Entertainment that is formally disapproved of is sometimes arranged by a group of soldiers. This can range from the highly illegal, such as the abuse of drugs, to the not strictly illegal, such as the ‘roof race’ custom in one regiment, which involved climbing out of an upstairs window and going round the roofs of the barracks.⁹⁷

- *Informal discipline*. Bullying in the Army has become a high profile topic in recent years⁹⁸. In many cases the term is accurately used in that it refers to the systematic persecution of vulnerable soldiers for the personal pleasure of the bully. However, the informal imposition of discipline, which used to be a normally accepted part of the life of an Army unit⁹⁹, has become absorbed into the same concept and is therefore punished as ‘bullying’ whenever it is confronted by those

in authority. A certain amount still goes on, though now it has become part of the underlife because it is formally disapproved of and punished. 'Informal discipline' includes such action as the correction of a persistently smelly soldier by his peers in the same barrack room, "... you'd start [by] stealing his shoes and putting them in the bins."¹⁰⁰, the appropriation by his peers of the military equipment of a soldier who goes absent without leave¹⁰¹ and other measures which fall into the class of what Hockey calls 'unofficial sanctions' in his chapter on occupational values and beliefs¹⁰². Informal discipline also includes the punching of a soldier by an NCO superior,

"There is of course the informal discipline system which used to be expressed with punches and kicks from the sergeant major down through the sergeant, which still undoubtedly goes on, but not much of it because of the severe repercussions."¹⁰³

"... if you'd done something wrong you'd get belted in the back of the head, you know. And then again if you'd done anything wrong again ... you'd get a couple of good swift kicks or a couple of good swift digs you know. And then that would have been it over and done with. ... You know, it's a quick way to teach you a lesson. And it works."¹⁰⁴

It was not possible in the course of this study to quantify the scale of 'informal discipline'. Those who were asked about it all said that it still went on but very few current examples were given. This seems to reflect the severe attitude towards it taken at present by the chain of command, which probably discouraged my informants from elaborating on the subject.

Two important consequences flow from the fact that the underlife is by its very nature not formally constituted. First, although to a very great extent there is remarkable general agreement as to what is acceptable and what is not, it is continually subject to redefinition, interpretation and manipulation by individual agents, so disagreements can arise in particular contexts. Where there is a disagreement, it is more than likely that the interpretation of the senior person present will become the dominant one. The following incident illustrates this point nicely:

'... my sergeant major last summer 'found' a pickaxe (for use in an emergency destruction kit). Our corporal (RAF) complained at length that he had surely just nicked [stolen] it, and this wasn't on ... the [sergeant major] however announced that he had 'just found it', that we needed it (true) and therefore this was perfectly legitimate. Being the WO2, he had his way...' ¹⁰⁵

The second important consequence is that the identification of acceptable and unacceptable behaviour by the authorities can undergo changes that appear capricious to individual agents. Such changes can lead individual agents to make what turn out to be serious mistakes whilst acting in good faith. Perhaps the most stark examples are in the fields of ‘bullying’ and ‘informal discipline’ which we have just discussed. Over the past 30 years there has been a significant attitudinal change by the Army’s chain of command: at the start of this period there was an assumption that ‘bullying’ was in fact ‘informal discipline’ and was tolerated widely and was therefore accepted as legitimate. However, now any endorsement of ‘informal discipline’ has become an *illegitimate secondary adjustment*. Whilst individual agents can easily draw a distinction between bullying and discipline for themselves, their view is not necessarily shared by those with whom they are living, or their superiors - all of whom are of course different agents. What one party sees as ‘informal discipline’, and therefore a *legitimate secondary adjustment*, the party in authority sees as ‘bullying’, and therefore an *illegitimate secondary adjustment*. Indeed, there have been cases where the alleged bully clearly thought that he was meting out discipline in good faith and that he would be supported (if unofficially) by his superiors whereas in fact his superiors prosecuted him formally.¹⁰⁶

Special informal circumstances

Circumstances can arise when the conventions which constrain activity in the *informal structure* are either deliberately relaxed by those in a senior position or stretched and tested by those below. The following paragraphs give some common illustrations to provide a flavour for the situation, but they cannot provide a definitive list because the circumstances are so varied.

First, there are sporting occasions and adventurous training. On the sports field it is frequently found that everyone, regardless of rank, is called by their first name or their nickname for the duration of the game and the ensuing post-match celebrations¹⁰⁷. On adventurous training exercises soldiers and their officers find themselves in a semi-civilian environment and carry out challenging but not strictly military activity, such as canoeing or rock climbing. Much depends on the personality of the officers and the NCOs who are there at the time, but it is not uncommon for everyone to be on first name terms for the duration of the exercise. However, if nicknames are used they are generally restricted as terms of address from a senior to a more junior in rank.

Second, there are informal social events involving a mixture of ranks. Such events provide a ready arena where the unwritten rules of the *informal structure* are flexed and tested by junior individuals. The convivial atmosphere and the flow of alcohol can put most

of those taking part into a relationship at least as close as *informal access* for the duration of the event, and (depending on the event) a temporary state resembling *association* and even *friendship* can be found where it would not exist in other situations. However, even in these circumstances there are still limits which ought to be observed: as one private soldier put it, although when he was “down town” with his platoon sergeant he was allowed to call him by his first name, “you don’t abuse rank”¹⁰⁸.

It is so common that it is almost a military institution that when private soldiers get drunk in an informal gathering which includes their platoon or troop commander they will attempt to call him by his first name and tell him what they think of him (mercifully the alcohol usually gives the rosiest of tinges to their views of the moment). This is not thought of as ‘abuse of rank’ so long as nothing is said that is deemed by those present to be too insulting, and as long as no violence is offered to the young officer.

On such occasions it is usually not so much that the structure itself is challenged or put under pressure, but rather that individuals acknowledge its existence but attempt to create or simulate a closer relationship within the existing structure than is normally permitted. In this way, for example, the private soldiers who are addressing their platoon or troop commander by first name are using the language of *friendship* to address someone with whom their normal relationship would probably be *informal access*.

A third example of circumstances where the conventions of the *informal structure* are commonly tested occurs when a junior officer is detached with a small number of soldiers for a period of days or weeks. A typical example was given during an interview with a platoon commander who described how when he was with some of his men on an isolated detachment in Belize a few of them tried to use his first name: “I felt it was wrong because they *know* [speaker’s emphasis] it’s wrong. They were just playing the game”¹⁰⁹.

Exercises and operations provide another context where the rules of the *informal structure* may be relaxed, particularly when pressure is low and there is time to talk. The absence of the more normal and structured life of the barracks provides opportunities for people to talk informally in a way that would not be appropriate in other circumstances. As one platoon commander put it, in the middle of the night when nothing is happening and he is in the company of just one of his men then “a couple of home truths might slip out”.¹¹⁰

Again, another officer said that after 16 hours waiting with some of his men for something to happen one can talk about anything and everything¹¹¹. Such occasions can be interpreted as providing the medium for relationships of *association* to arise where *informal access* or even *nodding acquaintance* might only have been appropriate before.

Finally, there are the rare circumstances under which the limits on open enmity are removed and fighting can occur. Violence among junior NCOs and private soldiers would conventionally be exercised in an out of the way place where the normal rules of conduct can be suspended: in some corner of the barracks where the influence of the *formal command*

structure (discipline) can be ignored for a time, or outside the barracks altogether. On the other hand, senior NCOs and warrant officers expressed the view that violence between members of the sergeants' mess, when it does occur, should only take place on the premises of the mess itself¹¹². This is illustrated by a case in which two warrant officers had a serious fight in an empty room in the all-ranks NAAFI building: it was remarked among their colleagues that the disciplinary action that followed could probably have been avoided if only they had fought in the sergeants' mess rather than in an all-ranks environment (albeit in a private room).¹¹³ Violence between officers is very rare, but if it takes place it will usually happen during the rumbustious aftermath of a mess dinner, in the officers' mess or its grounds.

When these special informal circumstances occur, it is normal for them to be contained in specific contexts of a limited duration. The one common element to all the examples quoted above is that the challenge to, or suspension of, the conventions of the *informal structure* only lasts for a finite time identifiable to all concerned and in a defined context. Operational tasks, exercises, parties and sporting events all have a finite term and nobody expects any changes specific to those occasions to last beyond that time. Thus even in extreme cases the conventions of the *informal structure* are not threatened or rendered unstable in the long term, even if they are temporarily suspended.

Effect on the individual

So far, the *informal structure* has been viewed from the outside, as an observer might see it. There is of course a complementary view, that of the individual soldier, and we turn to the individual in the third main part of this section. To give a representative (but scarcely comprehensive) snapshot of a unit, we will consider private soldiers, NCOs, and officers. However, it must be borne in mind that all NCOs and some officers begin their career as private soldiers so these categories are not exclusive through time: they represent snapshots in what might be an individual's long trajectory through several ranks.

Whereas the *formal command structure* provides the individual with an unambiguous definition of his position in the organisation and certain codified rules for his behaviour and for the behaviour of others towards him, the *informal structure* is very different. Although informal rules of conduct exist, and although there are customs and practices which circumscribe his choice of off-duty activity, they are not codified and he has to discover them for himself through the behaviour of his fellows. The moment, therefore, when the individual

arrives in a new unit is crucial, and so are the succeeding weeks as he absorbs the unwritten rules.

The newly arrived private soldier

In general terms, there are two kinds of newly arrived private soldier, the man straight from training and the man posted in from another unit. The former can be assumed to know little or nothing, and the latter to have a good idea of what the *informal structure* consists of.

For single unit organisations such as the cavalry and the single battalion regiments of infantry, the most common new arrival will be the soldier from training ‘fresh from the factory’, as it is sometimes put. All interviewees agreed that under non-operational conditions there was some form of induction process for such people, often taking up to several weeks. For example, in many cases nobody spoke to the individual for a period of time (unless he was lucky enough to have friends from training in the same situation), and he was unable to find drinking companions for a night out. In one (extreme) case, a young soldier was given no bed space for the first week which meant that he had to sleep on two chairs pushed together and he had no rights over any part of the accommodation¹⁴. In other more exotic cases individuals have been put through initiation ceremonies, usually involving the consumption of unusually large amounts of alcohol, ceremonies which are now officially banned because of fatal accidents.

The overriding requirement is that the new arrival should somehow have to earn his way into the *informal structure*: he must not be ‘mouthy’ to the more senior soldiers, and he must show that he can do his job professionally (he must not show himself to be stupid or incompetent: a ‘knob’ or a ‘waster’ or a ‘doughnut’, the language of different regiments varies but the meaning remains the same).

The beginning of the end to this period of informal induction is usually signalled by a gradual increase in the time that the established members will spend talking to the newcomer and the end often comes with an invitation to join in some informal activity. This might be, for example, a trip to a pub or even something as simple as sharing a table at a meal.

There is, however, an important difference under operational conditions. In this case a new soldier is normally accepted into the operational team with the minimum of delay, for the simple reason that the other members of the team have to rely on him for their own safety in dangerous circumstances. They will still watch the new arrival and assess his professional capabilities, but they will make his integration as easy as possible.

In the units of the Royal Engineers, Army Air Corps and Royal Signals the soldiers are subject to trickle posting, which means that they spend no more than three years or so in any one unit. In the Royal Artillery the majority of the soldiers spend most of their career belonging to one unit, but some are posted as individuals to other units. In all of these, therefore, while a proportion of the private soldiers arriving will be from the 'factory' others will have already been through the process of joining a unit elsewhere. For these more experienced soldiers the informal process of induction is different. Although they will be checked out by their peers (any reputation they may have from previous units will be passed round by word of mouth, and their professional and social styles will be examined critically) there will be no need for them to prove themselves to the same extent as a soldier fresh from training.

Promotion of NCOs

Promotion to NCO rank is only given on the recommendation of the officers of the unit, a process that will always involve the Adjutant and the Commanding Officer. While there are certain formal requirements for promotion (mainly the passing of so-called 'career courses') the crucial determining factor is the impression that the individual has made on his superiors in the chain of command. Promotion is therefore an uncertain business with nothing guaranteed by length of service. Thus some soldiers receive promotion earlier than others, many never attain promotion at all, and it is possible to become stuck at any stage.

Because with promotion a soldier changes status in the *formal command structure*, he has to find a new position in the *informal structure*. It is a widely held view that the most difficult promotion is the first, that from private soldier to lance corporal or lance bombardier. For the first time the man has the authority and duties and responsibilities of a junior NCO, but his authority will fall over many of his *friends* with whom he will continue to be living and working in close proximity. He will still be on first name terms with them in all but the most formal of situations and, if single, will be living in the same accommodation. Off duty, he will still want to associate with his *friends*, though there may be a junior NCOs' mess (or corporals club) for him to go to without them and there may be a separate dining area for junior NCOs. Some never make the change successfully (either becoming distant from their *friends* so quickly that they lose their support, or never quite putting the necessary degree of structural distance between themselves and their *friends*), but the majority do so by maintaining a balance between *friendship* and authority in the different contexts provided by on- and off-duty activities.

While promotion from lance corporal/lance bombardier to corporal/bombardier involves further changes around the individual within the *informal structure*, the next big step is from corporal/bombardier to sergeant. Because this usually involves both a break from

friendship with junior NCOs and private soldiers and the beginning of membership of the sergeants' mess, which amounts to an exclusive club for senior NCOs and warrant officers only, it therefore involves a drastic change in the individual's position in the *informal structure*. Further, the sergeants' mess has its own *informal structure*, its own groups and *pecking order* (as we have seen already, on page 114) and the process of entering its membership and adjusting to its rules sometimes feels somewhat reminiscent of entering a new unit for the first time. This process is generally made easier for the individual by a convention that he is posted out of his current sub unit (and thus away from the majority of his *friends*) so he can make a fresh start with a new position in the *formal command structure*.

Promotion to warrant officer likewise alters the rank range of people with whom *friendship* is possible, and puts more people in the relationships of *association* and *informal access* than before. It also moves the individual up through the *pecking order* in the sergeants' mess and may or may not change his group affiliation within the mess. For example, one interviewee reported that the sergeant majors of his unit formed an exclusive group which cut across sub unit boundaries¹¹⁵; another noted that in a different sergeants' mess the groups were based on sub units and promotion within the sub unit did not alter one's membership of the group, though it did alter one's position in it¹¹⁶.

Finally, promotion to RSM removes the possibility of *friendship* within the unit, places the individual at the head of the *pecking order* in the sergeants' mess and removes him from any informal group. The only relationships (apart from *close friendships* from the past) which he may legitimately enjoy are *association* and *informal access*. Sergeant Peter D. described this situation for Tony Parker, "It's a funny system where you have an Army that prides itself on its spirit of comradeship, but that the top soldier doesn't have single comrade"¹¹⁷, or, as one ex-RSM put it more briefly but with some feeling, "It is a lonely job"¹¹⁸.

The newly arrived officer

The informal life of a newly-arrived subaltern fresh from officer training will be centred on the officers' mess. The details will differ from unit to unit, but (like the private soldier fresh from training) he will certainly have to endure a process of induction. During this process, he may for example have to spend some time (up to a matter of weeks and sometimes months) during which he is expected to defer to any other officer who has been in the Army longer than he has, and he may be put through a practical joke on arrival. He may also be expected not to start a conversation with the more senior members of the mess. Thus, until the period of induction is over he is prevented from forming any new relationship stronger than a distant form of *association*. However, if he has contemporaries from officer training in the officers' mess they may well form a group of *friends* in themselves: such groups will remain strong

while they have to be collectively subservient to the more senior members and will probably form the basis of enduring groups for the future.

The induction process for an officer who has just been promoted through the ranks (usually from Warrant Officer Class 1) is different. He will have at least 20 years military service behind him and possibly may have already formed bonds of *association* with other officers in the unit. There will be no question of him being looked down upon in the same way as a newly arrived officer straight from training, but he may feel uncomfortable in the presence of the younger officers of his rank with whom he has little in common at first. It is usual under these circumstances for such a man quickly to form *friendships* with other officers in the unit who have been commissioned from the ranks. Indeed, the commissioned warrant officers usually form an identifiable informal group in most officers' messes.

Where an officer is a member of a single-unit regiment, he is unlikely ever to have to join another unit, though exceptions can occasionally occur when a single unit Regiment has no right person for a key post (Second-in-Command, for example, or Commanding Officer), in which case appropriately qualified people are posted in from another unit. Where his regiment or corps consists of more than one unit (as, for example, the Royal Engineers, Royal Signals and Royal Artillery) then an individual will have to join several units in the course of his career. Here again, as in the case of the private soldier, once he has been inducted into one unit he will not have to go through the process again, though his social and professional style will be checked out by his new group of peers.

The officer's informal structure and promotion

Once established in the unit, the individual officer will fit his informal relationships into the pattern provided by the *informal structure*. However, in contrast to the private soldiers and NCOs, promotion for officers is much more even through time: people of the same age tend to be of equal or adjacent rank and to be promoted at roughly the same pace. We have already seen that the exceptions, the commissioned warrant officers (who are older for the equivalent rank), are likely to form a group in themselves: this group too will move through the system at a relatively uniform pace. Therefore there is less requirement than for private soldiers and NCOs for officers to alter their relationships as they are promoted. That part of the structure which surrounds them moves with them.

In the same way as the RSM may not form *friendships* with his colleagues in the sergeants' mess, the Commanding Officer may not form *friendships* with his officers. Here too, the only relationships which he can enjoy in the military environment are *association* and *informal access*. Circumstances will probably have prepared him for this in that he will be the only officer of his age group in the unit (so his contemporaries and *friends* will all be

elsewhere) and his time as a sub unit commander will probably have precluded him forming *friendships* with younger officers.

Effect of marriage

When a soldier marries, he will almost always adopt a new domestic life style, either living in married quarters close to his unit barracks, or living in his own house which may be some distance away. If his new home is too far away for him to commute daily to his place of work then he will continue to live in the appropriate single man's accommodation and his pattern of informal relationships is unlikely to undergo significant change. However, if he moves out of the single accommodation to set up house within reach of the barracks¹¹⁹, then it might be expected that his informal relationships will change, for the following reasons:

- He will no longer have the spare money to go out as often as hitherto. He will therefore be less able to participate in the informal entertainment that is characteristic of the exercise of a single man's *friendship*.
- He will be drawn to spend more off duty time with his new wife and less time with his *friends*.
- He will no longer be living with his *friends* in close proximity.
- His wife may wish him to change his circle of *friends*.

Remarkably, the great majority of married men interviewed on this subject were adamant that their patterns of *friendship* did not change. They said that they saw less of their *friends* than hitherto, but they saw enough of them at work for the *friendships* to be undamaged, and they always had the opportunity to invite their single *friends* to their house in the evenings and at weekends. Several made the point that they still saw their *friends* at social occasions such as sub unit parties or mess functions. A few said that their *friends* increased in number because they met new neighbours whom they did not know as single men¹²⁰.

It seems therefore that the nature of *friendship* lends itself to the adjustments due to marriage because *friendship* does not need to be constantly exercised to survive. This is another manifestation of the capacity of *friendship* to endure periods of separation (either structural or physical) mentioned on pages 98 and 99.

It is also worth noting that soldiers spend considerable amounts of time deployed away from their barracks as unit or sub unit groupings, either on exercise or operations, and

on such occasions the influence of wife and family is diminished and the effects of the *informal structure* are enhanced.

Conclusion

The *informal structure* comprises a body of ideas, rules and conventions of behaviour which are not written down and are acquired purely through interaction between individual agents. Although, being informal, they appear to permit a large array of free choices for the individual, in fact they are to a great extent systematic and constrain and mandate the action of individual agents. One of the key areas within the structure is the system of different types and intensities of informal relationships which connect every member of a unit in many different ways to many other members, within the constraints of rank and position in the *formal command structure*. These relationships are sufficiently systematic for them to be modelled into five categories only. The structure provides a vehicle for soldiers to cooperate with and befriend each other and it also puts limits on the degree to which individuals can fall out.

We have seen how the *informal structure* is worked out in the daily lives of soldiers by considering a sample of topics, namely group formation, the effects of the passage of time, informal hierarchies, terms of address, the underlife of a unit, and special informal circumstances. We have also have looked at the trajectory of individual private soldiers, NCOs and officers and considered the effects of marriage on their informal relationships.

The next section looks at the rules and conventions that are concerned with belonging to the various levels of organisation within the unit.

SECTION FIVE - THE LOYALTY/IDENTITY STRUCTURE

"The Army's full of people who think they belong to the best organisation - and it's true for everybody! It's true for everybody, it's a sort of miracle." ¹²¹

Introduction

The *loyalty/identity structure* of combat arms units consists in a set of ideas, assumptions and expectations centred on a concept which is best called 'belonging'. However, this concept of belonging is multi-level and highly flexible because each soldier has several possible organisational levels to which he belongs.

In the description part of this section, the essentials of the structure will be set out. In the second part we will then consider the effect that it has on the individual.

Description

The structure is easiest to see in its manifestation as a nesting series of groups, varying from size between 3 or 4 soldiers up to the full unit, each one being an element of a larger group. Initially, therefore, we will look at this aspect. These *loyalty/identity groups* are defined by the *formal command structure*, in that they are identified by the formal divisions of the unit into sub units and lower organisational segments. Indeed, when drawn out on paper, there is no distinction between the groupings in the two structures. Together they resemble what a soldier might call a 'wiring diagram' or an anthropologist might call a 'segmental lineage system'¹²², and two examples can be seen in Appendix D. However, in contrast to the *formal command structure*, where behaviour is hierarchical and marked by disciplined deportment, behaviour in *loyalty/identity groups* is marked by cooperation and mutual support between members of the *operating groups*, and is observably more relaxed.

A soldier in one *loyalty/identity segment* belongs to all the segments above his level as well as that group, and is expected to give each of them a degree of loyalty and support and to defend their reputation. For example, in the artillery regiment in Appendix D, a soldier located in a particular battery would be expected to be committed to the well-being and success (however defined by context) of all of the following groups:

his gun detachment, his troop, his battery, his regiment, the Royal Regiment of Artillery, the British Army, the Armed Services, Great Britain, and any alliance of which Great Britain is a part and in support of which she has deployed his regiment.

His battery commander, on the other hand, does not have membership of troops or gun detachments, but is a member of his battery, regiment, and so on.

As this study is limited to consideration of social structures at unit level, only the first four levels are strictly relevant here. However, it is as well to recognize that the system goes onwards and upwards.

Groups based on the *loyalty/identity structure* are distinctive from informal groups in that they contain wider rank and age ranges. For example, in the artillery battery considered above there would be a major, three captains, two subalterns, three warrant officers, one staff sergeant, ten sergeants, about 20 junior NCOs and about 60 gunners. This feature lends *loyalty/identity groups* a special characteristic in that all their members, regardless of age, rank and structural position, have the same rights of membership of the group and share the same obligations to support it. Through their shared commitment to it, members of a *loyalty/identity group* thus share a degree of equality when the *loyalty/identity structure* is the *operating structure* that is entirely absent from the *formal command structure*. This is best seen during a sporting occasion, where the most junior member of a *loyalty/identity segment*

is likely to show exactly the same enthusiasm in support of the team representing that segment as the most senior person in it.

The structure, however, is more than just a series of groupings. It consists in all the conventions and shared expectations connected with the approved behaviour of a member of any particular *loyalty/identity segment*, at any particular level. Some of its more obvious manifestations in soldiers' lives at unit level are set out under the headings which follow.

Combination and recombination

It is self-evident that a soldier cannot focus his allegiance simultaneously on all the potential groups formed by the *loyalty/identity segments* to which he belongs. It is therefore a feature of the *loyalty/identity structure* that the appropriate focus for loyalty is determined by the context of the moment, and specifically by the group against which his group is being compared or opposed. Two illustrations from the sports field will demonstrate this point:

- It is theoretically possible for, say, a Royal Signals troop to produce such a fine football team that the same individuals form not only the troop team but also the squadron and regimental teams. A soldier from the troop would be correct in cheering for that troop by name in an inter-troop match but not in an inter-squadron or inter-regimental match. At such matches he would cheer on his squadron and his regiment respectively, in spite of the fact that the members of the team are the same on all of the occasions.

- In the more usual case, the members of teams of larger groups are drawn from all the available smaller groups of which it is composed. In the artillery regiment in Appendix D, members of the unit football team might come from all four batteries, and the battery teams from both troops in the battery. Now the soldier on the touch-line (let him come from C Troop, 23 Battery) finds himself cheering on members of his troop in a game against D Troop, members of both C and D Troop (the former opponents) in a game where 23 Battery plays against 6 Battery, and members of all batteries, including 6 Battery, in a game against another unit.

These examples illustrate one of the most distinct features of the *loyalty/identity structure*, which is its flexibility. The size and scale of the segment of the moment is determined by the segment that it is being compared with, or is in opposition to, and this changes with changes in context. Thus in the course of a working day an individual can find that his active segment in the *loyalty/identity structure* changes many times. For instance, a soldier may well find himself parading with his troop/platoon in the morning, attending a sub

unit briefing mid-morning, supporting a unit sports team in the afternoon, and being part of his section quiz team in a bar games night in the evening.

Soldiers can, therefore, find themselves in opposition to a particular individual at one moment, when their *loyalty/identity groups* are in opposition, and in cooperation with the same individual a short time later when their *loyalty/identity groups* are in combination against a larger, structurally opposed group.

Special areas of the structure

For each of the combat arms, there is one special level in the *loyalty/identity structure* for which feelings run particularly high. The appropriate level is either the unit (the battalion for the infantry, for instance, and the regiment for the Royal Armoured Corps), or the sub unit (for the Royal Artillery, Royal Engineers and Army Air Corps). These are what I have called '*loyalty hot-spots*'.

Sometimes there is no obvious opposition by which soldiers can identify the appropriate *loyalty/identity segment*. Such occasions might arise, for example, when they are away from their units on leave or on courses. For such occasions the structure contains a level which is always present in the background - what might be called a *residual focus of loyalty*. This focus tends to be at the level above the unit, either the 'Regiment' (for the Royal Artillery, the Royal Armoured Corps and the Infantry) or the 'Corps' (for the Royal Engineers, the Royal Signals and the Army Air Corps).

Distinguishing marks

At certain levels, *loyalty/identity segments* are distinguishable by particular characteristics, such as visible symbols or intangible prerogatives and traditions, to which they have an exclusive right. This area is a highly complicated one, but the simple examples that follow serve to illustrate the point.

- Infantry and Royal Armoured Corps units have rights to a unique suite of battle honours, have their own customs traditions and reputations, and may have animal mascots, while their Regiments have distinctive designs of uniform and capbadges which no other Regiment shares.

- On the other hand, in the Royal Engineers such differences are vested in the sub units: squadrons have exclusive distinctions (including battle honours, the right to fly distinctive flags and exclusive rights to display certain colours and logos). There are no such distinctions at unit level in the Royal Engineers, though its

members are distinguishable as fellow members of the Corps of Royal Engineers by their dress and capbadge.

- In the Royal Artillery, the same type of sub unit distinctions exist for batteries as for squadrons in the Royal Engineers. There is, however a further distinction above unit level between those units in the Royal Horse Artillery and the rest. This difference expressed in the exclusive right of members the Royal Horse Artillery to wear a particular capbadge and belt.

These levels, at which the *loyalty/identity segments* display their uniqueness, generally coincide with the *loyalty hot spots*.

Function and dysfunction

The *loyalty/identity structure* exerts considerable influence on the minds and attitudes of soldiers, and this influence can be experienced both positively and negatively in terms of military performance.

The positive elements are best summed up in the drive to be ‘the best’. Most soldiers interviewed were adamant that their *loyalty/identity segment* in the particular context of the interview was ‘the best’, for example:

[In reply to my question, “If you had to nominate the best battalion [in your Regiment] would you have any hesitation in choosing?”] “Oh, you’d have to pick your own. I don’t think that anyone believes that any other battalion’s better than their own.”¹²³

“Oh I do like Charlie Company. Charlie Company’s the best company in the battalion. ... ‘Cos it’s the best bunch of lads and that. The lads are brilliant you know. They’re good, and all the platoon sergeants and all the full screws [corporals] are good.”¹²⁴

“Wherever you are, whichever regiment, you’re always the better battery. I think that’s all to do with your team spirit. ... Throughout the Army that is what we want to do - we want to be better than anybody else.”¹²⁵

Only two interviewees said positively that their unit was not the ‘best’ and both of them confessed that they were ashamed of saying so.¹²⁶

The implication of this desire to be best is that, when the *loyalty/identity structure* is the *operating structure* soldiers will expend much effort to achieve more than their rivals. This by its very nature enhances the overall achievements of the *loyalty/identity group*.

Being 'the best' has another positive function, and that is that the identity of the group is reinforced and its cohesion enhanced. When soldiers were asked, 'What, in your opinion makes soldiers stick together?' virtually all of the replies included some or all of the following:

- Common Regimental or Corps identity
- The desire to be the 'best' as a unit, and also the best at platoon/troop level
- Belonging to a common organisation.

There are, however negative aspects. The first is comparatively mild, though it can bring problems to commanders in extreme cases. Sometimes the members of a group hold on to their self-identity as 'the best' in spite of obvious evidence to the contrary. Even when outperformed militarily and on the sports field and when suffering from inefficient leadership and administration, members of *loyalty/identity segments* can still have the capacity to convince themselves that nothing is really wrong.

Secondly, soldiers can be so filled with feelings about the appropriate *loyalty/identity segment* that they will not lightly tolerate any change to what they see as its 'character', as is exemplified by the fight between the warrant officers in the NAAFI mentioned earlier (page 123). This fight was caused by a deep disagreement over the handling of a *loyalty/identity segment* which was brought to a head during the formal annual celebration of that segment's identity. On the larger scale it is a common experience that soldiers in the infantry and Royal Armoured Corps find it hard to adjust to the amalgamation of their units. The loss of the identity of old units can arouse bitter feelings among their erstwhile members, and there can be serious barriers between the soldiers of different unit origins in the new unit. Such things can be ascribed to a forcing together of two different *loyalty/identity structures*.

Thirdly, the rivalry between *loyalty/identity segments* can be carried so far that it leads to difficulties. A case in point discovered during an interview with an officer who had been a member of a training team working to assist infantry battalions to convert to a new armoured vehicle. The first unit that they were deployed to was a Guards battalion, and there was friction between that battalion and the team. The single Guards officer in the training team got on well with the host battalion, but all the other officers found it difficult to work with them and as a result the conversion was not as effective as it might have been.¹²⁷ The problem appears to have been that the Guards officers felt that they were innately superior to the members of the team, and the members of the team were too ready to believe that the Guards officers were disinclined to learn from outsiders.

Rivalry between *loyalty/identity segments* can even reach a state of mutual hostility expressed in lack of cooperation in the face of external opposition that ought to unite them: in some cases this hostility can lead to violence. Soldiers from certain infantry battalions, for example, readily get into fights with members of certain other ones when they are off duty, a situation I had first hand experience of in the early 1970s, during an air defence exercise in Germany. We were sharing our camp with two infantry battalions, and the officers of both units were very concerned because they had a long standing mutual hostility. This hostility was manifested in off-duty fighting within a few days¹²⁸. Similarly, as another illustration, there is no particular love lost between the Royal Artillery and the Royal Engineers.

Other people's morale

An interesting manifestation of the *loyalty/identity structure's* capability to define 'the best' was regularly demonstrated by the Army Personnel Research Establishment's 'Continuous Attitude Surveys' and those of the DERA Centre for Human Sciences (privatised in April 2002 as part of QinetiQ)¹²⁹. As part of Army-wide surveys on soldiers' attitudes towards the Army, a sample of some 2,000 soldiers was asked three times a year to rate their own morale, that of their work group and that of their unit as a whole. The results consistently indicated that, no matter what the satisfaction or dissatisfaction expressed, individuals of all ranks said that their morale was higher than that of their work group and that their work groups' morale was higher than the unit's as a whole. Thus the smaller *loyalty/identity segment* is generally believed by its members to have higher morale than the larger of which it is part.

Effect on the Individual

As with the other structures, the *loyalty/identity structure* has an influence on the life of the individual soldier, as well as on groups within the unit.

Membership of loyalty/identity segments.

We saw above how there was a process to be gone through for a soldier to enter the *informal structure* in any depth (pages 124 and 125). No such process is necessary for membership of a *loyalty/identity segment*. The only criterion for rights and obligations of participation in *loyalty/identity groups* is membership of the relevant *loyalty/identity segment*, irrespective of rank and experience. An individual is a full member simply by virtue of being posted into it, and fully entitled to support it, represent it, and defend its reputation from that moment

onwards. Here is a soldier from the Royal Engineers remembering his first day in his first unit, at the very bottom end of the prestige scale, and without the proper issue of equipment:

“I arrived in the middle of an ACTIVE EDGE [a no-warning call-out exercise] and I didn’t have a sewing kit with me and I didn’t have scrim [camouflage garnish material] - at the time we had to wear scrim on our helmets. So they [members of his troop] all chipped in.”

Interviewer: “Even though you were a new sprog [young and newly-arrived soldier]?”

“Yes, Sir. Because I was part of their troop. Although I was a sprog, I was *their* sprog [interviewee’s emphasis]. And nobody else was going to ridicule me apart from that troop.”¹³⁰

Analysis: Although the interviewee had no status, and in other circumstances might have been left to fend for himself as best he might, in this case the reputation of the *operating group*, the *loyalty/identity segment* [the troop], was at stake and its members protected him from ridicule from outside. This implies that he was a full member of the segment from the very beginning, with no probationary period. This would not have been true of the *informal structure*.

Conversely, a soldier’s membership of a *loyalty/identity segment* only lasts until the time he leaves it for another segment. An illustration from my own experience will illustrate this point:

In a Royal Artillery regiment, there was deep rivalry between two of the batteries, one of which ‘owned’ the colour red, and the other the colour blue. One of the troop sergeant majors in the red battery was promoted to the position of BSM [Battery Sergeant Major] of the blue battery. As he had been a long term loyal member of the red battery for over 15 years, some people wondered if he could really transfer his allegiance properly. He settled the question by asking his erstwhile (red) BSM for a piece of red carpet to take with him. Some, including the red BSM, thought that he wanted a small piece of red to remember his old battery by. He settled the matter, having been given the carpet, by saying, “Thank you: I wanted this piece of carpet so that I can wipe my boots on it each morning!”¹³¹

In passing, it should be noted that individuals hold a special affection for their *loyalty/identity segments* in the past. However, this affection usually only manifests itself at reunions, where membership of current *loyalty/identity segments* is not an operating issue and individuals temporarily recombine in *loyalty/identity segments* that are part of their past. These situations are special and bounded, much as the *special informal circumstances* covered in the description of the *informal structure* above.

Marks on the person

The *loyalty/identity structure* can also be expressed by physical attributes displayed by members of particular loyalty groups. Beevor remarked that:

‘some regiments even seemed to produce a physical stereotype - willowy cavalry officers with flopping hair, slim Green Jackets with saturnine good looks, and large, fair-haired and ruddy-faced officers in the Scots Guards - but the exceptions almost certainly outnumbered such a thumbnail rule.

Clothes were a better guide. A waisted, full-skirted hacking jacket ‘cut in the cavalry style with ticket pocket’ was hard to miss, but to specify the regiment required a mass of minor clues, ranging from the jacket’s state of repair to the visibility of a polka-dot handkerchief; while a Coldstreamer who had the cuff buttons of his grey suit arranged in two pairs, like those on his uniform, presented no challenge, and if a gunner could not be spotted by his dapper pinstripe, his labrador would give the game away.’¹³².

Although Beevor says that these differences are not so marked as they used to be, he has come upon an identifiable feature of the *loyalty/identity structure*. Soldiers, and particularly officers, in many ways acquire physical marks that distinguish them from members of other *loyalty/identity groups* (mostly at Regimental or Corps level). Bourdieu’s concepts of *habitus* and *bodily hexis*, outlined in Chapter One, are particularly relevant here: individuals absorb a sense of how to act and respond in the course of the multiplicity of experiences in their lives. They acquire a sense of what is appropriate behaviour, and this behaviour is manifested in what Bourdieu calls the ‘practical sense’:

‘The practical sense is not so much a state of mind as a state of the body, a state of being. It is because the body has become a repository of ingrained dispositions that certain actions, certain ways of behaving and responding, seem altogether natural.’¹³³

These ingrained dispositions, according to Bourdieu, result in adjustments of the body¹³⁴, which are manifested in such things as bodily attitudes and movements, ways of cutting and dressing the hair, speech (both words used and accent), and clothing. They are displayed as part of the natural attributes of the individual (they are ‘ingrained dispositions’). A soldier acquires the ones that distinguish his *residual focus of loyalty* early in his career, as the following extract from notes of an interview with a member of the Foot Guards illustrates,

‘He told an anecdote about five men, all from Liverpool, who joined the Guards’ Depot as recruits on the same day. [Liverpool is a common recruiting area for all five Guards regiments] Although they were from the same civilian culture, within 2 weeks they had become recognizably different from each other, according to

Regiment. They had acquired Regimental characteristics in that short time, during which they were all doing the same training in the same place and together.’¹³⁵

Conclusion

The *loyalty/identity structure* consists in the bundle of ideas, rules and conventions of behaviour that confer on soldiers their sense of belonging to and representing certain organisational segments in the unit. These segments form a nesting series of groups defined by the *formal command structure*. An individual belongs to many such groups in a series from very small (‘section’, ‘gun’, ‘tank’ and so on) through troop/platoon, sub unit, up to unit and beyond. His membership is an automatic consequence of his posting into a particular part of the formal unit structure.

When the *loyalty/identity structure* is the *operating structure*, the appropriate segment is defined by the level at which his *operating group* is opposed or contrasted in the context of the moment, and it can change from moment to moment. Thus it is expressed in level group rivalry and recombination in the face of larger organisational groups, and has thereby an intrinsic flexibility and dynamic quality. *Loyalty/identity groups* embrace both vertical and horizontal dimensions in that equal membership is enjoyed by all members, regardless of rank and service, such membership acting as a bonding quality promoting the unity of the group. Where there is no visible opposition there is an appropriate level in different Regiments or Corps on which loyalty can be focused (a *residual focus of loyalty*). Certain levels (*loyalty hot spots*) can provoke particularly powerful emotions of loyalty and belonging, and these levels tend to be those at which certain segments (the level differs between different Regiments and Corps) display their uniqueness.

The *loyalty/identity structure* provides the *loyalty/identity segments* with a strong force for unity and encourages the individual soldiers to aspire to be ‘the best’. On the other hand, it can also lead to complacency, resistance to change, and disruptive rivalry between segments.

The structure is often expressed in the form of distinguishing physical attributes displayed by its members. These attributes tend to be defined at the Regimental and Corps level.

So far we have examined social structures whose prime characteristic is membership, either acquired or ascribed. The final social structure is more focused on military activity: a structure of doing rather than belonging.

SECTION SIX - THE FUNCTIONAL STRUCTURE

He seemed keen to tell me that his philosophy was that the job, the common task, was the overwhelmingly important thing and that everything else should be subordinated to it. Nothing else matters but doing the job.¹³⁶

*We are warriors! We are Warriors!
We've got a rifle!
And a bullet!¹³⁷*

Introduction

The *functional structure* consists in the ideas, rules and conventions of behaviour that are connected with carrying out what soldiers see as soldierly tasks. In this section we will look briefly at the nature of those soldierly tasks, the groupings which arise from the *functional structure*, and the attitudes and mental models which soldiers hold concerning soldierly functions. All are manifestations of the structure.

The third part of this section is a discussion of a critique made by Killworth on the version of the *functional structure* set out in my defence fellowship.

Description

What soldiers see as soldierly tasks ranges from the intuitively obvious, such things as weapon handling, fieldcraft, and the driving of military vehicles both on and off roads, to the less obvious but nonetheless soldierly. Such less obvious soldierly activities include, for example, lighting a cigarette or a cooking fire in high winds and heavy rain, keeping one's kit dry in the field, cooking military rations with a palatable result, holding one's liquor on a night out, and attracting women.

Although the *functional structure* does not provide a background framework for general activity in the same way as the other structures do, the carrying out of soldierly tasks is a major element in military life: indeed some would say that it is the *raison d' tre* of a military unit. As many tasks (particularly in barracks) do not exactly fit the groups which the other structures can make available, soldiers spend a proportion of their working hours in transient functional groups. Furthermore, it is relatively common for commanders at all levels to give high priority to the military tasks in hand and in the offing, and thus to give particular prominence to the *functional structure*. It is therefore a major factor in the lives of soldiers, and not unusually found to be the *operating structure*.

The exercise of professionalism in the face of a military problem, and the demonstration of one's ability to perform as a soldier is expected to, are self-evidently two of the basic ingredients of being a soldier, and it is no wonder that it lies at the heart of one of

the social structures in my model. Even Hockey showed that he detected this aspect, in spite of being hampered by his very narrow perspective (as I have shown in Chapter Two) by pointing out that ‘doing the job’ (any task that is associated with combat) is an important ingredient in soldiers’ lives, and by reporting a comment by a lieutenant that “There is more spirit and the lads seem more together when we have got something to complete, particularly in the field”¹³⁸.

I will first consider functional groups, because they are an obvious manifestation of the *functional structure*. I will then consider some of the more important other aspects which the model captures.

Functional groups

The size and composition of a functional group vary with the task: sweeping a garage, for instance, might only require two or three soldiers, whilst erecting a tented camp for a subunit to live in for three weeks would require considerably more, especially if it is to be done to a tight deadline. Not infrequently, the formation of different sized groups for different tasks is made simple because both the *formal command* and *loyalty/identity* structures define military groups that offer a variety of scale and capability. The right size and composition is therefore available to meet many different functional requirements.

However, there are many occasions when both administrative and operational tasks emerge that require the putting together of soldiers from different segments of the *formal command* and *loyalty/identity structures*, and sometimes from different units entirely, into *ad hoc* groups. The function that they are called upon to perform is the only reason for such groups’ existence, and this function therefore provides its purpose and the bonding forces, weak or strong, which keep the group together. In these respects the groups formed within the functional structure resemble the ‘Action Sets’ identified by Mayer¹³⁹ but in this case the field from which group members can be drawn is restricted by the boundaries of the unit and therefore would be more limited than in Mayer’s more open example taken from Indian local politics. I therefore prefer the term *functional groups* for the purposes of this thesis.

The following cases illustrate the point:

- *Guarding the Barracks*. The routine provision of a guard for the barracks out of working hours is seldom the task of a complete segment of a unit. In some units it is an overnight duty for selected soldiers who return to work the next day, whereas in other units men are taken away from their designated jobs for a period of several weeks and formed into a special ‘RP’ [Regimental Police] troop or platoon which works on a shift system. In either case, there is no guarantee that the members of

the guard all share common membership of an appropriately sized formal command or *loyalty/identity segment*. Furthermore, the guard will contain a number of junior NCOs who will have authority over their subordinates in the guard, but these subordinates may not necessarily be the men that they would normally command. The provision of a rear party considered on pages 80 to 81 above is another example of the need to form special groups for the task of maintaining barracks security.

- *Grouping*. It is common practice on exercise, and an accepted part of British tactical doctrine, that the structure of a military group is changed in the face of different operational tasks. This is achieved by what is called 'grouping' of elements of one unit or sub unit to work with those of other units or sub units, and this 'grouping' can take place several times in one day. The fighting group that is thus formed is neither a formal command group, a *loyalty/identity segment* nor an informal group. It is a functional group.

- *Reinforcement*. Sometimes individual soldiers or small groups are needed to reinforce a different unit. Such reinforcements are usually chosen because they can be expected to have the relevant military skills, but they will only be able to participate fully in the unit's social structures on arrival if they had previous service with that unit. When forces were assembled for the Gulf War in 1990, several operational units were deemed to be too small for the task ahead and were reinforced by soldiers from other units. These other units were not expected to be operationally deployed, and could therefore bear the loss of some of their personnel. Until they had acquired informal relationships and adjusted to the new command structures that they now came under (and adjusted their *loyalty/identity* frameworks) the newcomers were chiefly tied to their new units by shared function. In other words, function provided their only *operating structure* to start with. This extract from my field notes cites a particular case:

'I asked about the considerable influx of outsiders [of which my interviewee was one] to his regiment to bring them up to war establishment for the Gulf War¹⁴⁰, and he replied that it was a bit of a problem because at first they did not feel fully part of the regiment that they had joined. This lasted until after they had integrated as a team through an intensive training period.'¹⁴¹

Although the form of a functional group may not be taken directly from the *formal command structure* it can be expected to contain within it a system of authority and responsibility which is considered to be a necessary feature for the carrying out of tasks,

especially under adverse conditions. Where there is a rank structure in the group it will be used; when all the members are the same rank, for example a small ‘fatigue party’ of private soldiers for routine labouring tasks¹⁴², it will still be usual for the person setting the task to designate one man to be in charge.

An important feature of functional groups is that they are usually transient. Once the common task has been achieved, the group can be expected to be disbanded because there is no further reason to keep them together. If the group also happens to be a *formal command*, *loyalty/identity*, or *informal* group in its own right then it will of course persist, but without function providing the *operating structure*.

Because of the normally transient nature of functional groups, their cohesion is usually stronger when there are other social structures present as well, to provide mutual reinforcement of the social bonds, as I have argued elsewhere¹⁴³. The *functional structure* can therefore be considered to be less bonding in its own right than the other structures.

I did, however, come across two examples where functional groups became so long lived that they began to take on a permanence that caused social changes in the units that were noticeable to the soldiers. The first was a case in which an infantry battalion was reorganised for the Northern Ireland role on functional lines, with the result that the rifle platoons were divided into two ‘multiples’ and thus were effectively split in half for the duration of the pre-deployment training and the deployment itself. As the soldiers spent virtually their entire Northern Ireland tour in these functional groups of half-platoons, social relationships became focused on the functional group rather than the other possible groups provided by the *loyalty/identity structure* and the *formal command structure*. As a member of one of those platoons said during an interview,

“The best I’ve ever seen our company, Sir, was just before we went to Northern Ireland ... November the year before. ... From senior ranks down, Sir, everybody was... you know, your mates and there was... you really felt you were one big, you know, like, family type thing. Just before we went, Sir, it was, you know, we were all in one room and we were all... and that’s when everybody’s emotions sort of like came out. Everybody was, ‘Ahh, remember when we were doing this...’ ... and while were in Ireland Sir, for six months ... everything was fine. But then when we come back, everyone just... the platoon was split in half ... into two multiples, and it sort of like changed the platoon cos the multiple... that’s sort of like the cut now ... The platoon’s ... split now.”¹⁴⁴

The second case involved a different infantry battalion and took place during another six month operational tour, this time in Cyprus. An officer who was there at the time told me that,

‘During a UN Tour in Cyprus, the then CO had decided to keep the battalion in two halves, half working with the UN and half in the Sovereign Base Area. So far, this was normal practice, but unlike the normal practice he had decided not to change them over half way through the tour. This meant, among other things, that the half of the unit serving with the UN received the UN medal and the others did not. The CO chose to command personally the half that was with the UN. The split into two halves was geographical, by role [function] and by command structure because a parallel structure was created by the CO in the half he was not with - a local Lt Col commanded it, it had an Adjutant and an RSM - all set up by the real CO. The split between the two halves was therefore nearly complete. So great was the split that the CO himself was prevented at one point by a gate guard from entering the part he was not with when he tried to visit it, and the “real” RSM was invited to a party by “RSM Dhekelia”. This did not go down well with the CO and the RSM.’¹⁴⁵

Here we see that there were several factors at work, including what could be seen as an understandable reaction to what appeared to be a capricious distribution of campaign medal-earning opportunities. However, it is also clear that a split within the unit had developed along functional lines, between the half that was with the UN and the half that was in the Sovereign Base area, and that at least the half in the Sovereign Base Area had acquired a separate identity and internal structure.

Attitudes and mental models

Although groups are an easily observable manifestation of the *functional structure*, there is much more to the structure than groups alone. One of the central areas of the *functional structure* is the set of attitudes that soldiers hold towards tasks. We have already seen how Hockey identifies military tasks associated with combat as drawing the commitment of the soldiers he observed. Killworth provides further confirmation in noting that the soldiers he observed went out of their way to volunteer to join in with another platoon’s training in pistol shooting¹⁴⁶. In contrast, he also describes an opposite case in which soldiers showed distinct lack of commitment to a task. This task was erecting tents for a fair to publicise aspects of the Army:

‘Elements of 2 Platoon were assigned to assist for the week. By chance I also knew the Staff Sergeant to whom they were responsible, from an ACIO [Army Careers Information Office] . She later complained about how they would always group together and work extremely slowly:

[She complained] “You would send them out and say ‘these tents all need putting up’; you’d come back and they’d all be in one big group again. So you’d split them up and in half an hour they’d be back again, the privates and the lance-corporal, with the corporal again. It was like they couldn’t operate on their own”

....

It was not seen by the contingent as *real* work and there was little perceived compulsion to carry out the tasks.¹⁴⁷

As Killworth observed, the erecting of tents for a fair did not have the cachet of more soldierly activity such as pistol shooting, and therefore the soldiers did not have an attitude of commitment to it.

The functional area that generates the strongest attitudes is most likely to be an operational deployment, seen as the ultimate test of military function.

[Of being in the Gulf War and on operations in Northern Ireland]: “For an infantry soldier you’re actually doing what you’ve been trained to do. You know that everything you do is for real, like. When you’re doing exercises and all that you don’t put everything into it because it’s no’ real. But when you was in the Gulf or you was over in Ireland you put everything into it because you know your next mistake ... if you make a mistake that could be you gone, you know. So you do everything for real over there. If I could get a chance to do a two year posting to Northern Ireland ... I’d take it straight away. I really liked Ireland.”¹⁴⁸

I saw this demonstrated during my fieldwork in the case of an artillery unit that was preparing to be deployed to Northern Ireland in the infantry role. The unit, which contained about 30 female soldiers among about 500 male ones, had been reorganised from its normal artillery-role structure to a new structure based on four-man patrols (known as ‘bricks’ (subsequently, ‘teams’¹⁴⁹)). As this organisation did not require as many soldiers, choices had to be made as to who should stay behind. The majority of the female soldiers were selected to stay in England and this led one of them to complain to me that she was now being rejected by her erstwhile (male) friends.¹⁵⁰ In this case the attitude of the soldiers to their new military function was stronger than their informal bonds. These informal bonds were being re-aligned along the lines of the newly created functional groups because of the importance of the military function that they were about to be committed to.

As well as attitudes to various functions and tasks, the *functional structure* is also manifested in shared mental models about how to achieve them. For example, it is an important military quality to be able to match groups to tasks. In some cases there are formally stated rules, (such as ‘Standing Operating Procedures’), as to the appropriate group size and composition for particular tasks (the unit guard for instance). However, in other cases such things have to be worked out, and the person making the calculations (whether he is aware of it or not) draws on a shared fund of knowledge as to the size and structure of groups demanded by different types and magnitudes of tasks. This is manifested in a feeling that the answer to such calculations is easy to derive.

Effect on the individual

Having looked briefly at the *functional structure's* influence on the collective lives of soldiers, we can now consider its effect on the individual soldier. Two elements stand out.

First, the *functional structure* gives the individual an ever-present frame of reference by which to gauge the likely significance or importance of what he is doing in the eyes of his peers, and this will prompt his commitment to it. A soldier will not want to appear backward in functionally important areas, but neither will he want to be overly committed to tasks that are thought of as unnecessary, or low in status. However, an important feature of this structure is that there are in fact few absolute standards to judge these things by: the definition of 'functionally important areas' is not as obvious as it might seem. Attitudes to particular tasks cannot be inferred purely from their nature or from consideration of the physical and mental resources needed to carry them out. They are a product of the prevailing *functional structure*, which can develop and change with the process of time. This point is illustrated by a junior NCO's remark to me that things had changed in his unit: years before, when he joined it, the attitude of his colleagues to personal camouflage on exercise was very slack - "if you put a bit of scrim on your helmet then you were thought of as being 'keen' [in a sneering voice], but now look at us!" [pointing out a well camouflaged group of soldiers]¹⁵¹.

Given that there is no obvious and permanent standard by which to define the importance of a particular soldierly function, mistakes can be made by individuals. Here is an example from Hockey, showing how an individual made a miscalculation by treating something as trivial when he should have treated it with soldierly respect, according to the prevailing *functional structure*:

'The squad is formed up and about to move off. The Sergeant in command is joking with a private about the latter's beret, maintaining that its style is that of a raw recruit. The private's nickname is used by the Sergeant, and there is lots of laughter from the squad. As the Sergeant turns away the private who has 'lost' the joke, points his weapon at the Sergeant's back in a mock fashion, grinning. The Sergeant perceives it out of the corner of his eye, spins around and in a very loud, fierce and serious tone, tells the private - using his surname - that if he ever points a weapon at a person again, "you won't have a head to put your hat on, and what's more I'll gaol you!" The Sergeant then orders all members of the squad to assume the correct position of attention. The squad is very quiet.'¹⁵²

Analysis: The sergeant was ridiculing the beret, which was not shaped in the way that a proper soldier would have it (as defined by the conventions of the *functional structure*). The sergeant was behaving in a general way which indicated that the *operating structure* was the *informal structure*, but when the soldier violated one

of the basic principles of the *functional structure* by using his weapon in a lighthearted and potentially dangerous way, the sergeant jumped suddenly into the *formal command structure*.

Secondly, this structure helps to define a soldier's status in the eyes of his peers. This status can be expected to increase with service as he acquires more and more mastery over the soldierly skills that are valued in his particular unit. This means that most soldiers' status can be expected to go up whether or not they are promoted: they will either become NCOs or 'senior soldiers'. I am indebted to Killworth's critique of my concept of the *pecking order* examined above in so far as he makes this point that military performance is an important ingredient in a soldier's prestige (and hence, in my terms, his position in the *pecking order*). It is easy to conflate this aspect with length of service *per se*, as I originally did¹⁵³.

Where a soldier's military performance is generally low, his status can be expected to be low. Here is a generic description of such a soldier, given by an experienced private soldier,

"Someone that's been a waster at the Depot and scraped through. He'll come here and he'll suffer. Maybe [on] his first exercise you just look at him and think, 'That man is shite. He hasn't got a clue.' Then you hear the rumours that he's just scraped through the Depot ... because they need the numbers. He'll start getting hammered - not physically, but hammered for, you know, 'We need a bloke for the QM's, you get yourself up there because we know you're a knob.' ... Normally you find that blokes who are like that will stay like that and they will do as little time in the Army as they can."¹⁵⁴

It is the same for young officers as for private soldiers. Military competence is sought after and cherished as a necessary ingredient of prestige and what is known as 'credibility'. As Killworth noticed, the platoon commanders he observed felt the need to claim superiority through military competence, and stressed the importance of their attendance on the Platoon Commanders' Battle Course as proof of that competence.¹⁵⁵ In contrast, here is a generic description of a low status officer, given by an experienced subaltern,

"Someone who's for ever putting his foot in it with the blokes and with his fellow officers. Someone who's just not on top of his job. Initially when you get there obviously you get quite a lot of breathing space. Obviously there's a very very steep learning curve. The blokes understand that."¹⁵⁶

Should the soldier's performance of functionally significant tasks not improve, then he will remain low status, whatever his experience. Such are the 'rejects' described on page 113.

Killworth's critique of the concept of the *functional structure*

The *functional structure* provides one of the significant points of disagreement between Killworth and my earlier description of the model¹⁵⁷. The full critique is on pages 109 to 112 of his PhD thesis¹⁵⁸: it may briefly be summed up in the following extracts:

‘An initial difficulty with this presentation is that it links three distinct social features. It is true that *ad hoc* work groups are formed in the Army to deal with particular tasks, but it is also the case that work groups are formed in the rest of society wherever group tasks are required, often sharing the characteristics of transience and task-specificity. Similarly, almost any organisation that employs personnel in group tasks has a shared body of ideas of how to accomplish these tasks. It is, however, also true that the infantry do share an ideology of professionalism expressed through the idea of ‘doing the job’ and an attachment to a method of work division termed ‘tasking’. These three elements, functional groups, professionalism and tasking, are however not necessarily inter-linked in the way that Kirke suggests.... In short, the mapping of professionalism or ‘doing the job’ onto functional groups is simply untenable: it is in fact much more complex.’¹⁵⁹

‘Kirke almost entirely neglects the other side of this formulation, however, in that functional groups are normally formed by use of authority by higher ranking personnel. The missing aspect of Kirke’s analysis is that the formation and operation of functional groups is inevitably bound up with the operation of power and the formal command structure.’¹⁶⁰

Once again, as with the *pecking order* (see pages 114 and 115 above), I find little to dispute in Killworth’s critique, except to point out that he has confused soldiers’ groups, which are one expression and manifestation of the social structures of the model, with the *social structures* themselves: the body of ideas, rules and conventions of behaviour which informs groups of people or individuals how to organise and conduct themselves vis- -vis each other. This confusion was probably caused by the fact that I used soldiers’ groups as a running concrete example for the model throughout the document. Nor do I dispute his observation that there are power and hierarchies present in almost every aspect of unit life, which indeed is reflected in the concept of ‘superiority and inferiority’ described below.

I see no difficulty, therefore, in accepting that his ideas, on power and prestige systems in the Army (based on fieldwork with the infantry), can sit beside this model and each can illuminate the other.

Conclusion

The *functional structure* thus provides a defining framework for attitudes to particular tasks that soldiers undertake, and for judgement of the worth and standing of an individual by virtue of his ability to undertake them. Such attitudes develop through time, and although there is a basic ingredient that ‘soldierly’ tasks are important, the exact definition of what is ‘soldierly’ and what is not is a social process that changes with time.

The structure often forms the basis for the formation and subsequent disbandment of *ad hoc* functional groups which are matched to the intended task, which is an important ingredient in the bonding of the groups concerned.

SECTION SEVEN - INTERACTION AND INTEGRATION OF THE STRUCTURES

Introduction

Although the four social structures in the model have been described separately, they must not be considered in isolation from one another. The ideas, rules, and conventions of behaviour captured in the model should be viewed as intertwined and overlaid in an intricate and complex pattern and as co-existing in some form of mutual balance. This section examines the interaction of the structures and the balance between them, and some important common ground which I have called ‘superiority and inferiority’.

Interaction

There are two types of interaction between the structures that are particularly important in the context of this thesis. The first is the tendency for elements in one structure to inform the other structures and the second is the constant potential to switch *operating structure*.

Reading between the structures

The aspects that are modelled in the separate *social structures* do not exist in isolation, but, because they are experienced as a whole in the run of life, they constantly interact with and inform each other. Indeed, we have already seen how some of the ideas and conventions of one structure have an effect on some of the others in the case of the effect of military prowess (*functional structure*) on the status of an individual in the *pecking order* (*informal structure*).

Another example would be the way in which particular aspects of the *formal command structure* contribute to the unit's *loyalty/identity structure*, as in the following example:

I have been attached at different times to a Foot Guards regiment and a Household Cavalry regiment. In the former, the soldiers were very punctilious about saluting, which was always carried out in the prescribed drill book manner which includes regulation movements and invariably the wearing of head dress at the time of the salute. In the latter, the atmosphere was less formal: salutes were exchanged, but not as vigorously, and as this regiment had a tradition in which non-commissioned soldiers saluted with or without headdress I was often surprised to be saluted by a bare-headed soldier.¹⁶¹

Analysis: The different modes of salute in the *formal command structure* were important identifying elements in the *loyalty/identity structure*.

A third would be the case where informal behaviour in the officers' or sergeants' mess is regulated by the Commanding Officer or RSM through the *formal command structure*, as in the following case,

An 'Italian Night' in the officers' mess got seriously out of hand when some officers and their ladies began to throw food at each other. The Commanding Officer responded by ordering the PMC [President of the Members' Committee] (who, as the officer responsible for the organisation of the mess, was ultimately responsible also for the conduct of its members), and the sub unit commanders who were present at the party, to report to him the next day in their best uniform. He gave them a serious rifting [ticking-off]. Behaviour in the mess became more orderly thereafter.¹⁶²

Constant switching of operating structure

Because all four structures are present simultaneously, it is unlikely that one will remain the *operating structure* for an extended period of time. For example, a private soldier in barracks might pass through all four in a single morning, thus:

0815: sub unit parade (*formal command structure*)

0830: weapon training and range work (*functional structure*)

1000: NAAFI break (*informal structure*)

1030: inter-platoon shooting competition (*loyalty/identity structure*)

1130: OC's Orders (*formal command structure*)

1200: lunch (*informal structure*)

Similarly, the context of the moment can instantly change, as in the case on page 80 when an officer approaches an informal group of privates enjoying a 'smoke break' and the senior soldier calls the group to attention. In that case, the *operating structure* switched from the *informal* to the *formal command structure* and than back again when the officer told the men to relax, all in the course of a few seconds.

This capacity of the system frequently to change *operating structure* has a number of consequences, of which these are common instances:

- Each structure provides separate and complementary channels of communication because each contains a different alignment of individuals and relationships.
- The normal case is that constant realignment of the structures prevents any single structure from tending to remain dominant, and thus no arrangement of groupings becomes permanent. This endows the system with a flexibility and suppleness that under normal circumstances prevent insurmountable personal or structural barriers growing up within a unit.
- The combination of widespread communications and constant changes of context provides checks and balances on dysfunctional behaviour because circumstances regularly arise in which any (even the most senior) members of a unit can be corrected or encouraged by other members.

A further feature of the system is that when all the structures are in harmony then group cohesion and military effectiveness are enhanced, even in the most stressful circumstances, as an equivalently strong bonding process is taking place in all structures. This means that they will continue to promote bonding whatever the *operating structure* switches to at any time, as I have explored in my analysis of the social processes taking place in an infantry company attack¹⁶³.

Balance

The model suggests that it is advantageous for the morale and efficiency of a unit if the four structures are kept in balance. Too much emphasis on the *formal command structure*, for example, can reduce communications in the *informal structure*; too much emphasis on the

loyalty/identity structure can allow the importance of military performance to decline in favour of maintaining team spirit and unit cohesion, and so on.

The following case provides a clear illustration of this need for balance,

In a particular unit the new Commanding Officer discovered that military performance was below what he expected. He therefore resolved to lift the standard. The method he chose to achieve this increase in standards was to cut through what he perceived as 'slackness' by making life difficult for his subordinates. He rigidly and publicly dominated his officers and senior non-commissioned officers by openly instilling fear in them and subjecting them to public ridicule if they failed to present the soldierly image that he wanted to see. He set very high standards of military achievement and became openly furious at any failure to attain them. He stressed the importance of a strong personality in his officers (his own personality was a dominant one and he had plenty of energy with which to exert his dominance). During his two and a half years in command, the majority of his officers felt ill at ease and were delighted when their time came to be posted out of the unit. Over the same period an impermeable clique of officers (favourites and 'courtiers') grew up around him and those outside this circle trusted each other less and less. The unit became fragmented as the sub unit commanders cut themselves off from the Commanding Officer as far as they could. Instead of rising, military performance standards fell.¹⁶⁴

Analysis:

The Commanding Officer's public domination of his subordinate commanders and other authority figures in the unit undermined their positions in the *formal command structure*.

The *informal structure* developed impermeable fences. The members of the Commanding Officer's clique were avoided and mistrusted by the other officers, and partial barriers arose between those other officers who were no longer certain that they could trust each other. This constricted the channels of informal communications that would otherwise have flowed through relationships of *friendship* and *association*.

The fragmentation of the unit was in part caused by lack of use of the full extent of the *loyalty/identity structure* which did not operate much above sub unit level.

The *functional structure* became at least partially diverted into avoiding trouble from the Commanding Officer at the expense of carrying out the military job in hand.

The continued stressing of importance of military function over all other considerations led to the dominance of the *functional structure* over the other three structures. The resulting imbalance sapped the unit's morale.

Comment:

Overall, the very methods which the Commanding Officer chose to raise military standards resulted in their further reduction because they caused disturbances in the unit's social structures.

Apart from demonstrating the negative results of imbalance between the *social structures* this case illustrates the fact that there is room for a person in authority, the Commanding Officer, the RSM, or a sub unit commander for example, to vary the balance of structures in the segment of the unit over which they have influence or control. This is an important consideration as it shows that the *social structures* are amenable to influence or control and are not, therefore, as fixed as they may appear at first sight.

An unexpected conclusion of this study was that the appropriate balance varies between Regiments/Corps and between units within Regiments/Corps. Indeed, the feeling of what constitutes the appropriate balance seems to be an important aspect of unit and Regimental/Corps identity. For instance, the Foot Guards place a greater emphasis on the *formal command structure* in comparison to the *functional structure* than do the Parachute Regiment. Similarly, the *functional structure* is dominant in the Army Air Corps because of the exacting requirements of flying and servicing helicopters: indeed, in the Army Air Corps unit visited during the study the most usually manifested groupings within squadrons were entirely along functional lines (aviators, ground crew, and mechanics).¹⁶⁵

Superiority and inferiority

It will have become apparent in the descriptions of the four *social structures* above that in each one there is a distinct element of hierarchy. Each has a way of accommodating and expressing various forms of superiority and inferiority. The *formal command structure* defines the legally constituted hierarchy and lines of authority; the *informal structure* contains ideas of superiority and inferiority manifested in such aspects as the *pecking order* and in the conventions of the rank-asymmetrical informal relationships described as *association* and *informal access*; the *loyalty/identity structure* has the idea of being 'the best' as a basic ingredient, and credit and prestige are awarded according to ability to 'do the job' in the *functional structure*.

It will also have become apparent from this chapter that from an individual's perspective the definition of who is superior to whom and where the inferiority lies is not the product of rational logical analysis. It depends very largely on agency and context. Here Killworth and I are in agreement, though we approach from different directions and ultimately draw different conclusions. He uses 'authority' in a sense that is close to my 'superiority':

‘If authoritative discourse, through which we perceive authority, is dependent upon the nature of the instance of articulation for its meaning, then it can be seen that this meaning is not fixed. With different social agents, either as speakers or audience, discourse takes on different meanings. Deriving from this observation, *different understandings* [italics in the original] of authoritative discourse, in effect different meanings, emerge according to the position of the individual actors involved. ‘Authority’ is constantly interpreted from multiple perspectives, there is no simple link between an utterance and ‘authority’.¹⁶⁶

These observations present something of a logical anomaly. On the one hand, as I have determined, there is a clear assumption of superiority and inferiority that informs all agents in most contexts, but on the other hand there can be no absolute agreement as to precisely what is superior to what, or who to whom, in any structure apart from the *formal command structure* because there is no absolute rule or fully agreed standard by which to decide. There always seems to be room for the statement, “I am better than you” or “we are better than you” in the mouth of any individual. And yet, somehow, individuals and groups manage to cooperate effectively in terms of living in harmony and achieving what are commonly identified by them as worthwhile goals.

We must therefore accept the existence of a constant presence of ideas of superiority and inferiority whilst noting that it does not necessarily imply oppressive management of individuals, groups, or situations, or disharmony in the minutiae of daily life.

It was suggested by one of the interviewees who had not seen regimental service in the field army that this element of superiority and inferiority indicated that there was, in fact, only one *social structure*, and that was the *formal command structure*¹⁶⁷. This structure, in her eyes, dominated all aspects of life. It is to be hoped that this chapter has shown that this is not the case, but her observation does highlight the fact that the *formal command structure* is a resource that those senior in rank can always call upon, with an assurance of success in most contexts, to establish their authority (and thus their superiority) over those who are junior and thus inferior in the *formal command structure*. It is always potentially present, as it were, even when it is not the *operating structure*.

It would seem relatively simple to match this constant background presence of the *formal command structure* to the constant ideas of superiority and inferiority which I have detected, and argue for a kind of covert dominance for that structure, even when another *social structure* is the *operating structure*. By this argument, all ideas of superiority and inferiority are manifestations of the *formal command structure* in a hidden form, reflecting the fact that it is a dominant feature of soldiers’ daily lives. It is a short step from this argument to say that the *formal command structure* is the ‘dominant’ structure in soldiers’ lives.

However, such an argument is too simplistic. It might equally be suggested, for example, that the apparent universal and ready acceptance of the *formal command structure*

by all military agents is a manifestation of generic norms of superiority and inferiority that are embedded in the culture of the Army, perhaps acquired by individuals in their early training where their instructors have power and authority over all aspects of their lives, whether formal, informal, functional or connected to identity.¹⁶⁸

We are not going to resolve this discussion here, and in any case it is not necessary. It is enough for our purposes to note that there is a constant theme of asymmetry - superiority and inferiority - in soldiers' daily lives which needs to be presented as a basic ingredient in all four structures in the model. For the sake of completeness, therefore, it would be best to include as a formal note to the diagram in Figure 3.1 that all structures contain ideas of superiority and inferiority.

SECTION EIGHT - CONCLUSIONS

This final section provides a summary of the top level of the model and the typology of informal relationships in the form of two master diagrams and notes attached to each.

The model

The top level of the model of four *social structures* (shared bodies of ideas, rules and conventions of behaviour which inform soldiers how to organise and conduct themselves vis-
-vis each other) can be depicted in this diagram,

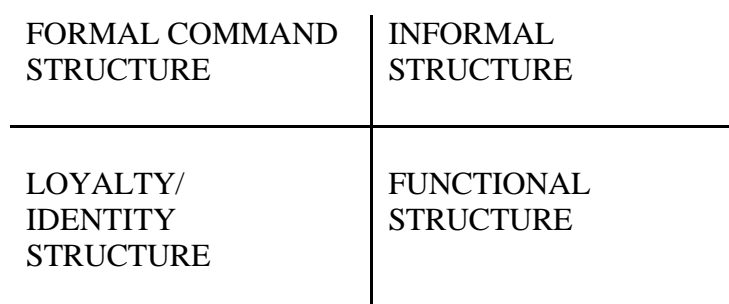

Figure 3.8. Social Structures in Combat Arms Units - Top Level

(Author's diagram)

Notes to Figure. 3.8:

1. Soldiers' activities in the context of the unit fall in one or other of the four social structures depicted in this diagram.
2. An individual can only be exercising one social structure at any particular instant.
3. The social structure of the context of that instant is called the *operating structure*.
4. Lower levels of the model represent greater degrees of resolution, revealing greater complexity.
5. The structures inform each other in matters of detail and are intertwined and overlaid in an intricate and complex pattern and co-exist in some form of mutual balance.
6. All structures contain a constant ingredient of superiority and inferiority, though its particular manifestation is dependent on the context and the individuals in that context.

The available relationships in the *informal structure* can be depicted in this diagram:

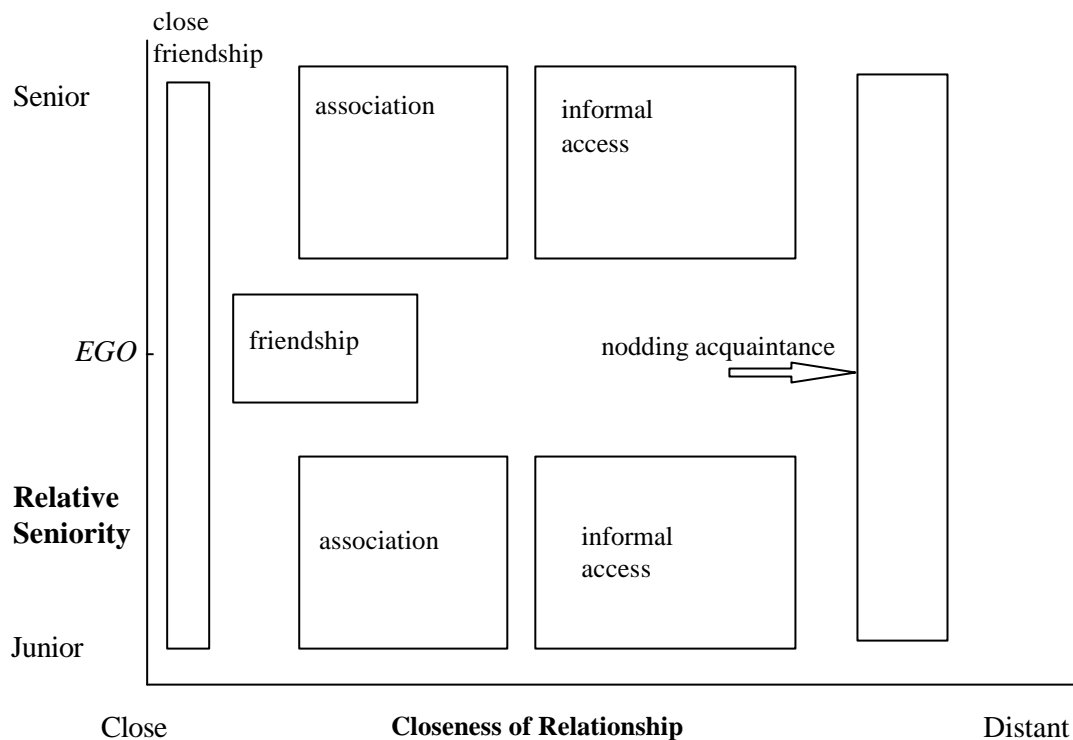

Figure 3.9. Relationships in the Informal Structure

(Author's diagram)

Notes to Figure 3.9:

1. The diagram is drawn on 2 axes:
 - a. Vertical axis, relative seniority. Any point on the axis is senior in rank to any point below it and junior to any point above it.
 - b. Horizontal axis, closeness of the relationship. The further to the left, the stronger the relationship, and vice versa. Each of the boxes in the diagram has a horizontal dimension which corresponds to various degrees of closeness on the horizontal axis of the diagram. On the principle that a line consists of a very large number of points, this incorporates a range of closeness or distance in any of the relationships which allows for a high degree of variety.
2. Soldiers' personal informal relationships fall within the boundaries of the diagram.
3. "EGO" is an individual of no particular rank who has some subordinates and some superiors in the unit.

4. The boxes summarise the various relationships available to *EGO*, the effects of relative rank, and the relative closeness or intensity of the relationships.
5. The gaps between the boxes have no significance apart from separating them on the page to make the model readable.

In the next chapter we will explore the power of this model of social structures to analyse, describe, and predict modern British soldiers' behaviour, compared with the power of other relevant models, which were introduced in Chapter Two, to do the same thing.

Notes to Chapter Three:

- ¹ Moskos, C. and Wood, F. (eds.), *The Military: More Than Just a Job?* London: Pergamon-Brassey's International Defense Publishers, Inc., 1988, p. 3.
- ² Kirke, C., *op. cit.*, 2000.
- ³ Irwin, A., *The Social Organization of Soldiering: A Canadian Infantry Company in the Field*, Ph.D., University of Manchester, 2002.
- ⁴ An everyday incident recollected, 1984.
- ⁵ Kirke, C., *op. cit.*, 1988.
- ⁶ Anon. Military proverb.
- ⁷ Hockey, J., *op cit.*, p.3.
- ⁸ MOD, *Manual of Military Law Part I, 12th Edition*, London: HMSO, 1 May 2001.
- ⁹ MOD, *The Queen's Regulations for The Army 1975 (Including Amendment 24)*, London: HMSO, March 2001.
- ¹⁰ See Chapter One, pages 14 and 15.
- ¹¹ The current edition of this manual is MOD, *The Drill Manual*, D/DAT/13/28/97, 1990 (as amended 1991).
- ¹² Since that date, it should be noted, the procedures for summary jurisdiction have been revised to make them less robust.
- ¹³ Personal recollections of Battery Commander's Orders, 1983 to 1986.
- ¹⁴ A shorter but more cynical account with broadly the same ingredients can be found in Holles, R., *The Guide to Real Subversive Soldiering*, London: Elm Tree Books, 1985, p. 84.
- ¹⁵ Bellamy, C., 'Rank', in Holmes, E. R. (ed.), *The Oxford Companion to Military History*, Oxford: Oxford University Press, 2001, pp. 755-759.
- ¹⁶ Fieldnotes, 13 December 1993. This description would have broadly fitted all the offices of the Commanding Officers of the units that I visited. The latest example (Fieldnotes, 19 March 2002) fitted it exactly.
- ¹⁷ Fieldnotes, 23 September 1994.
- ¹⁸ Fieldnotes, 26 April 1994.
- ¹⁹ Fieldnotes, 23 September 1994.
- ²⁰ Fieldnotes, 17 March 1994.
- ²¹ This misperception is not, of course, confined purely to the public. Even Proud, an organisational psychologist working for the Defence Evaluation and Research Agency made the assumption that 'role and power culture ... make up a large part of [the soldier's] working life' (Proud, A., *Potential Effects of Army Unit Culture on Implementation of DBL*, Defence Evaluation and Research Agency., 1999, p. 29).
- ²² Anon. Military proverb.
- ²³ Infantry Corporal. Fieldnotes, 17 March 1994.
- ²⁴ The term 'underlife' was coined in Goffman *op. cit.*, 1968 and is explained in the appropriate part of this section.

²⁵ Barnes, J., *Social Networks*, USA: Addison-Wesley Publishing Company Inc., 1972.

²⁶ Sexual informal relationships are considered in Chapter Six.

²⁷ *Holy Bible*, King James Version, 2 Samuel 1: 26.

²⁸ Recollected conversation, August 1994.

²⁹ Recollected conversation, July 1994.

³⁰ Fieldnotes, 31 March 1994.

³¹ Fieldnotes, 17 March 94.

³² Fieldnotes, 18 December 1993.

³³ Fieldnotes, 14 January 1994.

³⁴ Fieldnotes, 8 February 1994.

³⁵ Fieldnotes, 18 December 1993.

³⁶ For most of the research period, sub unit commanders assisted the Commanding Officer in preparing their officers' annual reports. However, from the reporting year 2001 the task of formally writing these reports has been formally delegated downwards to sub unit commanders.

³⁷ 'Trickle posting' is the system where soldiers join a unit for a specific period of time (usually two to three years) and are then posted to another unit. This system is practised in the Royal Engineers, Royal Signals and Army Air Corps for instance, but not in single battalion infantry regiments or in cavalry regiments.

³⁸ Fieldnotes, 15 February 1994.

³⁹ Fieldnotes, 19 July 1994.

⁴⁰ Fieldnotes, 26 April 1994.

⁴¹ Fieldnotes, 18 December 1993.

⁴² Fieldnotes, 3 August 1994.

⁴³ Fieldnotes, 15 March 1994.

⁴⁴ Fieldnotes, 15 February 1994.

⁴⁵ Fieldnotes, 14 July 1994.

⁴⁶ Recollected conversation, May 1998.

⁴⁷ Fieldnotes, 26 April 1994.

⁴⁸ Fieldnotes, 21 April 1994.

⁴⁹ Fieldnotes, 31 January 1994.

⁵⁰ No exceptions to this statement were found during the study. However, it remains logically possible for a strict and formal commander to maintain structural distance from his officers and NCOs by having no informal relationship with them.

⁵¹ The food member is given the task of organising the menus for the officers' mess and ensuring that the catering account remains in balance. It is a thankless task and therefore devolves frequently on one of the most junior officers in the mess.

⁵² Personal recollection, 1971.

⁵³ Exceptions would occur where the private soldier and sub unit commander regularly meet in a particular context. They might, for example, be members of the same sports team or work in close proximity.

⁵⁴ Fieldnotes, 2 August 1994.

⁵⁵ Fieldnotes, 31 March 1994.

⁵⁶ Fieldnotes, 26 April 1994.

⁵⁷ See Chapter One, pages 11 to 16.

⁵⁸ Fieldnotes, 19 July 1994.

⁵⁹ Fieldnotes, 27 December 1993.

⁶⁰ Fieldnotes, 26 April 1994.

⁶¹ Fieldnotes, 21 April 1994.

⁶² Fieldnotes, 31 March 1994.

⁶³ Fieldnotes, 19 July 1994.

⁶⁴ Fieldnotes, 14 July 1994.

⁶⁵ Fieldnotes, 21 April 1994.

⁶⁶ The cleaning of barrack accommodation is now normally carried out by contract cleaners. In the cases where the cleaning is done to the satisfaction of the unit authorities 'block jobs' are minimal. However, in many barracks soldiers are required to improve on the standards reached by the contract cleaners.

⁶⁷ Fieldnotes, 8 February 1994.

⁶⁸ Fieldnotes, 27 December 1993.

⁶⁹ Fieldnotes, 14 January 1994.

⁷⁰ Fieldnotes, 21 April 1994.

⁷¹ Killworth, P., *op. cit.*, pp. 117ff.

⁷² Fieldnotes, 19 July 1994.

⁷³ Fieldnotes, 31 January 1994.

⁷⁴ Fieldnotes, 8 February 1994.

⁷⁵ Fieldnotes, 3 February 1994.

⁷⁶ Fieldnotes, 26 April 1994.

⁷⁷ Fieldnotes, 18 February 1994.

⁷⁸ Kirke, C. *op. cit.*, 1994, pp. 3-17 to 3-18.

⁷⁹ Killworth, *op. cit.*, p. 121.

⁸⁰ *Ibid.*, p. 120.

⁸¹ *Ibid.*, p. 122.

⁸² Different conventions apply with different ranks for use of the diminutive. For example, “Sarge” is only used by an inferior in rank. “Sar’nt” by itself is only used by a superior in rank, but either a junior or a senior person may use “Sar’nt” when coupled with the sergeant's surname. On the other hand, “Colour” and “Staff” can be used by all ranks in addressing a colour sergeant or staff sergeant (except in the Foot Guards where the surname is always used by the superior).

⁸³ Fieldnotes, 18 February 1994.

⁸⁴ Goffman, E., *op. cit.*, 1968, pp. 159-280.

⁸⁵ See the definition of ‘total institution’ on page 20.

⁸⁶ Goffman, E., *op. cit.*, 1968, pp. 171-176.

⁸⁷ *Ibid.*, p. 172.

⁸⁸ *Ibid.*, p. 180.

⁸⁹ Fieldnotes, 27 December 1993.

⁹⁰ “Buckshee” is a corruption of the word “Baksheesh”, used in the Indian Army to mean something extra or free.

⁹¹ Hockey, J., *op. cit.*, for example pp. 9, and 60.

⁹² *Ibid.*, pp. 20, 74.

⁹³ ‘Active revenge’ and the two following terms, ‘fun’ and ‘informal discipline’ are my terms, coined for this thesis.

⁹⁴ Fieldnotes, 8 February 1994.

⁹⁵ Personal communication, 1989.

⁹⁶ Fieldnotes, 31 March 1994.

⁹⁷ Fieldnotes, 15 February 1994.

⁹⁸ For attention in the Press, see, for example: Norton-Taylor, R., ‘Army acts as 43% of troops condemn bullying’, *Guardian*, 12 November 2002; Laville, S., and Gregoriadis, L., ‘Recruits “still ruled by fear at Army base”’, *Daily Telegraph*, 18 July 2002; European Court of Human Rights press release, ‘Hearings, 23-24 October 2001’, 18 October 2001, which contains a summary of the case of a soldier who claimed that he went AWOL because he was bullied; Sapsted, D., ‘Soldier “at point of suicide over bullying”’, *Daily Telegraph*, 3 February 2001; Burke, J., ‘Army bullies force desertions to a record’, *Observer*, 4 June 2000. See also MOD, Army Briefing Note serial number 25.02, released by DCCA [Directorate of Corporate Communications, Army], ‘Update on Issues Relating to Deepcut Press Coverage’, 7 November 2002, which contains a statement by the Minister for the Armed Forces on a re-appraisal of initial training (with particular reference to bullying implied). See also MOD, *Army Continuous Attitude Survey Serving Personnel (2), Main Report (draft)* (AG/DAPS Science/TR/8/2002/1) dated August 2002, which finds that 48 [not 43% as above] of those surveyed perceive that bullying is a problem in the British Army.

⁹⁹ For example, Beevor, A., *op. cit.*, 1990, p. 19, and Yardley, M. and Sewell, D., *A New Model Army*, London: WH Allen & Co Plc., 1989, p. 60.

¹⁰⁰ Fieldnotes, 27 December 1993.

¹⁰¹ I have observed this as normal and accepted practice, confirmed by my field research. In my experience, for example the NCOs and officers knew that it went on, and were never too hasty in securing an absentee's kit. In general, we gave an absentee about 48 hours before his kit was secured, which gave his fellows plenty of time to pilfer it.

¹⁰² Hockey, J., *op. cit.*, pp. 123-140.

¹⁰³ Fieldnotes, 31 January 1994.

¹⁰⁴ Fieldnotes, 14 January 1994.

¹⁰⁵ Killworth, P., personal communication, 4 January 2000.

¹⁰⁶ I was a witness to an example of this process during my service in a training regiment in the late 1970s. The individual protested his good faith right up to and including his Court Martial at which he was found guilty. Informally, his peers agreed with him.

¹⁰⁷ The potential effect on discipline of this custom has been the subject of considerable debate amongst those in authority and it has been rejected by a few. This minority of dissenters was represented by only one officer and one ex-RSM during the interviews for this study.

¹⁰⁸ Fieldnotes, 17 December 1993.

¹⁰⁹ Fieldnotes, 18 December 1993.

¹¹⁰ Fieldnotes, 8 February 1994.

¹¹¹ Fieldnotes, 26 April 1994.

¹¹² Most senior NCOs and warrant officers interviewed were reluctant to speak of violence in their mess because they said they did not want to give a false impression that it was common. However, only a small minority said that it never happened.

¹¹³ Personal recollection, 1985.

¹¹⁴ Fieldnotes, 18 February 1994.

¹¹⁵ Fieldnotes, 31 March 1994.

¹¹⁶ Fieldnotes, 18 February 1994.

¹¹⁷ Parker, T., *op. cit.*, 1985, p. 115.

¹¹⁸ Recollected conversation, August 1994.

¹¹⁹ Increasingly towards the end of the research period, single soldiers have been given formal permission by their Commanding Officers to cohabit with girl friends. In social structural terms this has the equivalent effect within the unit as marriage.

¹²⁰ In the small minority of cases where there were departures from this pattern, the personalities of the soldier and his wife appeared to be the determining factors rather than the type of unit.

¹²¹ A sergeant, Fieldnotes, 18 February 1994.

-
- ¹²² See for example Evans-Pritchard, E., *The Nuer*, London: Oxford University Press, 1940, pp. 192-194.
- ¹²³ Fieldnotes, 8 February 1994.
- ¹²⁴ Fieldnotes, 14 January 1994.
- ¹²⁵ Fieldnotes, 18 February 1994.
- ¹²⁶ Fieldnotes, 27 December 1993, and 15 February 1994.
- ¹²⁷ Fieldnotes, 26 June 1998.
- ¹²⁸ Recollected incident, 1971. This was the most serious incident of its kind that I have personally witnessed, but it appears to be a relatively common risk between certain Infantry regiments.
- ¹²⁹ For example, Hampson, A. and Lawton, D., *Army Personnel Research Establishment Continuous Attitude Survey (Soldiers) Period Ending 30 June 1992*, MOD: APRE Report 92RO33., 1992; James, M., Schmit, V., Weston, K., Price, J., Hampson, A., *The Army Continuous Attitude Survey: Report One, Main Data Report (DERA/CHS/HS3/CR 97143/1.0)*, Defence Evaluation and Research Agency, August 1997; James, M., Weston, K., Hampson, A., Jarman, J., *The Army Continuous Attitude Survey: Report Two, Main Data Report (DERA/CHS/HS3/CR 97255/1.0)*, Defence Evaluation and Research Agency, November 1997; Atherton, R., James, M., Weston, K., Wingfield, T., *The Army Continuous Attitude Survey: Report Three, Main Data Report (DERA/CHS/HS3/CR 980036/1.0)*, Defence Evaluation and Research Agency, January 1988; Atherton, R., Hampson, A., Weston, K., Kallmeier, V., *The Army Continuous Attitude Survey: Report Four, Main Data Report (DERA/CHS/MID/CR 980115/1.0)*, Defence Evaluation and Research Agency, April 1998; Atherton, R., Weston, K., Wingfield, T., Hampson, A., Kallmeier, V., *The Army Continuous Attitude Survey: Report Five, Main Data Report, (DERA CHS/MID/CR980158/1.0)*, Defence Evaluation and Research Agency; August 1998; Atherton, R., Weston, K., Hampson, A., Wingfield, T., *The Army Continuous Attitude Survey: Report Six: Main Data Report, (DERA/CHS/MID/CR980216/1.0)*, Defence Evaluation and Research Agency, November 1998; Atherton, R., Weston, K., Wingfield, T., Thwaites, S., *The Army Continuous Attitude Survey: Report Twelve, Main Data Report (DERA/CHS/MID/CR 000248/1.0)*, Defence Evaluation and Research Agency, May 2000.
- ¹³⁰ Fieldnotes, 23 March 1994.
- ¹³¹ Personal observation, 1977.
- ¹³² Beevor, A., *op. cit.*, p. 228.
- ¹³³ Thompson, J., 'Editor's Introduction', Bourdieu, P., *op. cit.*, 1991, pp. 1- 31, this p. 13.
- ¹³⁴ The main points of Bourdieu's thesis about adjustments to the body are set out in his chapter 'Belief and the Body', Bourdieu, P., *op. cit.*, 1990, pp. 66- 79.
- ¹³⁵ Fieldnotes, 21 April 1994.
- ¹³⁶ Fieldnotes, 17 March 1994.
- ¹³⁷ Recollected lighthearted soldiers' chant, done antiphonally on informal occasions. Personal recollections, July 1979 and September 1986.
- ¹³⁸ Hockey, J., *op. cit.*, p. 84.
- ¹³⁹ Mayer, C., 'The Significance of Quasi-Groups in the Study of Complex Societies', in Banton, Michael (ed.), *The Social Anthropology of Complex Societies* London: Tavistock Publications 1968, pp 97-122.
- ¹⁴⁰ The artillery regiment in question needed at least 20% manpower increment because the artillery unit peace establishment at that time was well below the war establishment. The root of this difference is mainly in the

extra number of people needed to handle war rates of ammunition. It was not deemed necessary to have them in the unit in peace when much smaller amounts of ammunition are used.

¹⁴¹ Fieldnotes, 31 March 1994.

¹⁴² 'Fatigues' are routine manual labouring tasks such as helping in the unit kitchen or picking up litter in the camp.

¹⁴³ Kirke, C., *op. cit.*, 2000.

¹⁴⁴ Fieldnotes, 21 April 1994.

¹⁴⁵ Fieldnotes, 17 March 1994.

¹⁴⁶ Killworth, P., *op. cit.*, 1997, pp. 110 and 111.

¹⁴⁷ *Ibid.*, p. 111.

¹⁴⁸ Fieldnotes, 27 December 1993.

¹⁴⁹ Killworth, P., 'The British Army in Northern Ireland: Internal Security Operations, Training, and the Cease-Fire', *Cambridge Anthropology*, **20**, No. 3, 1998, pp. 1-20, this p. 5.

¹⁵⁰ Fieldnotes, 31 March 1994.

¹⁵¹ Recollected conversation, 1985.

¹⁵² Hockey, J., *op. cit.*, p. 69.

¹⁵³ Kirke, C., *op. cit.*, 1994, p. 3-19.

¹⁵⁴ Fieldnotes, 8 February 1994.

¹⁵⁵ Killworth, P., *op. cit.*, 1997, p. 156.

¹⁵⁶ Fieldnotes, 8 February 1994.

¹⁵⁷ Kirke, C., *op. cit.*, 1994.

¹⁵⁸ Killworth, P., *op. cit.*, 1997.

¹⁵⁹ *Ibid.*, pp. 110 and 111.

¹⁶⁰ *Ibid.*, p. 112.

¹⁶¹ Personal recollections, 1973, 1983, 1984 and 1994.

¹⁶² Recollected incident, 1984.

¹⁶³ Kirke, C., *op. cit.*, 2000, p. 235.

¹⁶⁴ This case is based on events that I witnessed myself in the mid 1970s and discussed with others present at the time. It is also very close to a case that I discovered during my interviews in 1994 (Fieldnotes, 18 February 1994).

¹⁶⁵ Fieldnotes, 3 August 1994.

¹⁶⁶ Killworth, P., *op. cit.*, 1997, p. 174.

¹⁶⁷ Fieldnotes, 16 June 1998. The interviewee was a member of the AG Corps (ETS) and had worked exclusively in garrison or station educational centres, apart from her first tour which was in a training unit.

¹⁶⁸ See Hockey, *op. cit.*, Killworth, *op. cit.*, 1997, *passim*, for detailed accounts of the influence that recruit training instructors have over their trainees.

CHAPTER FOUR - EXPLORING THE MODEL

SECTION ONE - INTRODUCTION

The purpose of this chapter is to explore the power of the model to analyse, describe, and predict modern British soldiers' behaviour. In sections two to four, it will be applied to particular case material reported by myself and others; in section five we will assess its advantages and its limits, and finally in section six we will compare it to other relevant models.

The material in this chapter is all taken from my fieldnotes or from my personal recollections. As in Chapter Three, I have included both types of material because they complement each other.

As may be expected, I had a considerable array of data from which to select the cases. I made the particular choice of fieldnote extracts for this chapter using the NUD*IST data base tool¹ to provide samples of text that I had previously tagged as containing the appropriate degree of complexity and analytical interest. I used this means of selection because it provided a mechanism for choice that was refined enough to provide relevant material but not so selective as to produce only extreme or unique examples.

The choice of my personal recollections was made after the fieldnote extracts had been identified. I can claim no systematic means of selection for this type of material: I used intuition and experience simply to choose cases that had the capacity to complement the interview material in illustrating the points in question.

SECTION TWO - APPLICATION OF THE MODEL TO THE DESCRIPTION OF PARTICULAR CASES

So far, we have looked at each of the *social structures* individually and discussed their interaction and integration. We are now going to examine the use of the model as a tool to describe incidents in the life of a unit in barracks. Whilst this is the simplest use of the model, and its effectiveness may be inferred from some of the material already presented in Chapter Three, its examination is included here in order positively to demonstrate the power of the model in this role. Certain incidents observed by myself and others will be described in two ways: first in pure narrative form, and then using the model with its special terms in *italics* to indicate that they are being used rigorously as precise terms. However, as this use of the model may be so plainly demonstrated, we will confine ourselves to four cases only. One is from my field notes, one is recalled by me in retrospect, and the other two are taken from Hockey² and Killworth³ respectively.

Case One - A Soldier Describing Unofficial 'Fun'

The interviewee (a private soldier in the mortar platoon of an infantry battalion) described 'corridor parties', which involved drinking in the block (against orders). The parties were fun to plan, the details being circulated secretly by word of mouth. Most of the full corporals usually went out at the time the party was due to happen so that they would not be involved, but a few came, and they would make sure that it did not get boisterous. He made the point that the celebrations stopped short of 'Zulu Warrior' [boisterous striptease performed to a particular chant] because that would be too noisy, and I should bear in mind that his platoon were a sensible lot because they were full of senior and mature soldiers, not teenagers who don't know how to behave. He then recalled an incident in B Company lines when some of the youngsters got out of hand.⁴

Using the model:

The interviewee described an example of an *illegitimate secondary adjustment*. 'Corridor parties' would be arranged by passing round information through the communications provided by the *informal structure*. These informal communications enabled the full corporals unofficially to hear about what was to happen and to decide for themselves whether or not they would attend. He made the point that the members of his platoon (from Support Company) were sufficiently controlled to keep the noise down to levels where the authorities could reasonably ignore them, invoking the *loyalty/identity structure* to declare that they were capable of such self control, unlike other platoons who were full of less mature individuals.

This description helps us to appreciate the tension and balance in this situation between the acknowledged rules and the practice of bending them, whilst independently highlighting the importance of experience gained through length of service in the speaker's mind and the use of ideas described in the *loyalty/identity structure* as a means of expressing *superiority and inferiority*.

Case Two - A Message At A Party

The senior NCOs and warrant officers of my battery were holding a party in the sergeants' mess after I had been in my new regiment as the BC [Battery Commander] for about a month. They had invited the battery officers and their wives and we had all come. It felt a cosy, comradely event at which I felt I properly belonged, in spite of my newness. After the meal, the floor was opened for dancing and there was much partying and smiling and shouting against the noise of the music. All present appeared well lubricated with alcohol and were enjoying themselves accordingly. Suddenly, one of my two troop sergeant majors, Staff Sergeant Driscoll, approached me in the smoky semi-darkness and took me to one side. He told me that one of the battery's senior NCOs, Sergeant Wallis, was not being treated fairly. He went into some detail about how there were people in high places who had it in for him and how I had had the wool pulled over my eyes about him because I was new. I thanked him quietly for this information and he disappeared to the bar, to get on with enjoying himself. I had noticed that, curiously, his breath did not smell of alcohol at all. Later he became joyfully drunk and led the dancing in a wild way that probably had something to do with his Celtic ancestry.⁵

Using the model:

The battery NCOs and warrant officers were celebrating their identities as members of the battery hierarchy (*formal command and loyalty/identity structures*) and celebrating the battery's *loyalty/identity structure* by holding a party and inviting the battery officers and their wives (and nobody else). We, the officers, proclaimed our membership of the battery *loyalty/identity structure* by turning up and by relaxing enough to feel at home in the convivial atmosphere. Staff Sergeant Driscoll took advantage of the context to act as if it was a *special informal circumstance* under which he could approach me in a way that would not be possible elsewhere. He used the situation temporarily to simulate a relationship of *association* that did not yet exist between us (because of the short time I had been the Battery Commander) to tell me that I was being deceived and that one of my senior NCOs was suffering because of it. He deliberately manipulated the situation by behaving as might be expected of a subordinate who is drunk, whilst actually having taken little or no alcohol up to that point.

Here, the description allows us to identify the means whereby an individual agent found it comparatively simple to use the unstated conventions modelled in one of the *social structures* to exercise his own agenda.

Case Three: A Dramatic Contrast

A researcher's observation during a late stage in recruit training: "Recruits are keenly aware of the changes in treatment that occur within different locations, as one put it whilst on the final Battle Camp on the northern moors: 'It's better out here, not as strict as in barracks, you can have a laugh with the NCOs out here. Everyone's more relaxed in a way.'" ⁶

Using the model:

Recruits are sensitive to contrasting contexts. One of them drew a sharp contrast between the barracks context, where the *formal command structure* tended to be the *operating structure* and the context of the final Battle Camp on the northern moors, where the *functional structure* and the *informal structure* tended to predominate.

We can see here how an incident described by a different researcher not only fits the pattern of the model but is also easily re-stated using its terms.

Case Four: A Soldierly Complaint

In an infantry battalion in barracks, and during an otherwise relatively slack period, when there had not been much to do, 'The platoon were informed that they were working that weekend, information that produced general unhappiness. Cundell commented that "I don't mind so much if you're on exercise or something, you expect it. But this is just work for work's sake. Let's get some hand grenades and blow up the head shed [top person in the management] or something". Various comments were aimed at the CSM, who was held to be responsible for this decision in lieu of any other members of the company command at the time.' ⁷

Using the model:

When the platoon were told that they would have to work that weekend, after a week in which there had been little to do, there was general unhappiness among them. Nobody minded working at weekends when there was soldierly work to be done, as when they were in the field on exercise where the *functional structure* would be predominant. However, they perceived that this new work, outside the normal working hours of a unit in barracks was not consistent with the soldierly roles defined by the *functional structure*, and it was being imposed in what seemed to be an arbitrary manner through the *formal command structure*. This irritated Cundell so much that he made some violent (and almost

certainly empty) suggestions towards the man whom he saw was to blame, while talking informally with an *operating group* consisting of his *friends* in the context of the *informal structure*.

Once again, this case shows how the situation, words, and actions of soldiers reported by a different observer are amenable to description by a third party using the model.

Conclusion

A large number of further cases could be cited to continue to demonstrate the capability of the model to be used to describe soldiers' behaviour, but there seems little advantage in taking up more space on a point which is self-evident. These four cases show that soldiers' behaviour can be described using the objective and structured terms in the model. The added value which this simple procedure provides is that it shows how events reported in different places and by different researchers in the context of a British Army unit can be brought into a common frame of reference by expressing them in the model's special terms. Once they have been brought into this common frame of reference, they may be subjected to common treatment, for example a balanced comparison of equivalent features. However, this is the least of the model's capabilities and the easiest to demonstrate.

We now move on to the more exacting task of analysis, and, later, prediction.

SECTION THREE - APPLICATION OF THE MODEL TO THE ANALYSIS OF PARTICULAR CASES

In this section, we will go beyond pure description and use the model to analyse certain cases. As this is a more sophisticated use of the model, a larger set of examples will be taken.

Case Five: A Wise Sergeant Major

When I had been away at university for my first year of undergraduate studies I had returned to my regiment, now deployed to Northern Ireland on an emergency tour, during the long vac [university summer holiday]. I settled rather uncomfortably into Headquarters Battery as a spare subaltern. I had previously served exclusively in another battery, which was then deployed at some distance from where I was to spend my time, and most of the officers in the regiment had changed over while I had been away at university. I therefore knew very few of the people I was with. For me, it was a strange role and a strange place, populated largely by strangers. I had been affected by the free and easy life at Cambridge sufficiently to feel awkward about using the rank of a junior person as a term of address when I talked to them. I would therefore do my best not to call them anything at all. This had obviously been noticed because after a few days one of the sergeant majors in HQ Battery whom I scarcely knew took me to one side and told me firmly that the NCOs had spent a great deal of effort achieving their ranks and needed to be addressed by them. I listened to his advice, changed my behaviour and found myself more comfortable almost immediately.⁸

Analysis:

I had lost my feel for what I would later call the 'social structures' in the regiment. Furthermore, I had been put in a position where I had very few existing relationships and as I had not taken part in the training for the deployment I did not have the skills that the other members of the unit had developed. I was not therefore able to participate fully in the *informal structure* or the *functional structure*. By adopting the *no form of address* term of address to the private soldiers and the NCOs I was indicating poor engagement with the *formal command structure* as well. Because I was not in a relationship of *association* with any senior NCO at the time, the sergeant major used his relationship of *informal access* to correct my behaviour.

The analysis of this incident shows the factors that give a structurally weak position to a recently-arrived junior officer in a unit that has earlier undergone rigorous training and is already engaged in operations when he arrives. It also shows how a

formally subordinate individual (in this case a warrant officer), even on slight acquaintance, can correct the behaviour of a superior and thus help him to attain credibility as an officer. It also indicates the ease with which this can be accomplished without breaking any norms.

Case Six: Celebrations, But Against the Turn of Events

In 1985, a gun detachment in my battery (one of three gun batteries in the regiment) had won the annual 'Best Gun Competition', which was a much prized event. The following year the competition came round again and another battery took the title, leaving our top gun second. That evening we held a battery 'smoker' [informal all-ranks celebration], as did the other batteries. It was a thoroughly enjoyable and boisterous event which included loud and enthusiastic singing, spontaneous speech-making, and special 'Gunner' party games. The other batteries reported that we displayed a very high level of 'battery spirit': the other battery senior NCOs told mine, in conversation in the sergeants' mess, that we made the most noise and must therefore have had the most fun. How could this be, as we had lost?⁹

Analysis:

The battery smoker was a celebration of the battery's identity, drawing on the *loyalty/identity structure*. The noisy activities were primarily a statement of our worth as we saw it, to which the failure to win was not relevant. Whatever the result of the competition, we knew that we were really 'the best', and we made this clear through acting as a noisy *loyalty/identity operating group* consisting of all the members of the battery. The surprise expressed by the other batteries' senior NCOs was communicated through their *informal structure* relationships in the private and informal environment of the sergeants' mess. Their surprise reflected their beliefs that their batteries were 'better' than us: one battery had the Best Gun Trophy to prove it in their own eyes and the members of the third battery believed that we ought to be more ashamed at losing it than them who had simply failed to win it. Thus each of the batteries had sound reasons to believe that they were 'better' than my battery. This is a typical manifestation of the *loyalty/identity structure*.

Cases like these help to remind us that apparently anomalous behaviour may well result when the *loyalty/identity structure* is the *operating structure*.

Case Seven: An Ambitious Subaltern

Harry Cooper, a subaltern in the same battery as myself, was military highly proficient and had considerable personal courage. However, he was criticised by some of the soldiers under his command for ordering them to follow him into unnecessarily risky situations on operations in Northern Ireland. Such orders naturally carried with them the implication that he would deal with them formally if they did not do what he said. His soldiers believed that he was using them to impress his sub unit commander and his Commanding Officer with his prowess as a brave leader of men. It was my personal judgement when I occasionally patrolled with him that they were right. This is not to question either his personal courage or his military proficiency: both were of a high order. He was also noted by his peers for his assiduousness in speaking to the Commanding Officer and visiting senior officers (particularly the ones who might be in his reporting chain¹⁰) who were in a position to affect his future career.

His fellow subalterns did not like him, and his men distrusted him, as evidenced by this extract from my fieldnotes:

‘Harry continues to be difficult to get on with and annoys me intensely at times. He and Bob [the other subaltern in the battery] don’t get on at all’¹¹

and this statement on a wall in the soldiers’ ablutions:

‘Here we are in Snipers Alley
Then comes cooper [sic] Dillys and Dallys
Might as well all give it up
As hes [sic] as much use as a stringless mop.’¹²

‘Sniper’s Alley’ was the name given by the soldiers to a dangerous alleyway in the battery’s area of operations. The accepted practice was to get through it quickly and aggressively. Cooper, however, would court trouble by lingering in it. As he led his patrol, the soldiers were forced to linger with him.

Analysis:

This is an example of an individual manipulating the military social structures to his own advantage:

- *Formal command structure*: He made his soldiers take risks that they judged to be unnecessary by the use of formal authority.

- *Informal structure*: He attempted to establish informal relationships of *association* with those who could influence his future career. However, he was unable to sustain *friendship* of any closeness with his peers.

- *Functional structure*: By taking operational risks he was trying to establish a reputation as an operationally competent officer. However, in the eyes of his soldiers, and myself, the risks he was taking were greater than the conventions of the *functional structure* would require.

The price of these activities was paid in the *informal structure* within the unit. His informal relationships with his soldiers were impoverished by what they saw as his self-centred attitude to their lives, and he failed to form any strong *friendships* with his fellow subalterns because they disliked what they saw as selfish behaviour.

Although Cooper did not wield his formal authority constantly (indeed, like all of us, he exercised all four structures in the normal way), his soldiers accompanied him in his risky activity at least in part because they knew that formal sanctions were available to him, and this factor gave them little choice in the matter.

This case highlights the means whereby an ambitious individual can manipulate the norms and conventions represented in the model of *social structures* to further his own ends, and the consequences that flow for his reputation among his subordinates and peers. It also illuminates our understanding of the capacity of the *formal command structure* to act as a constantly available resource for commanders, even when it is not the *operating structure*, an aspect which we explored towards the end of Chapter Three.

Case Eight: A Difficult Sub Unit Commander

In this next case, my informant speaks of his time as RSM in an infantry battalion that was on a two-year operational tour in Northern Ireland. Battalions in this position had a 'reserve' role and were called upon to reinforce troops on shorter term deployments as necessary. It was the practice on such a tour to give the soldiers as much time off as possible because no one knew when they would be required to work at full stretch and for how long. A newly arrived company commander had begun his tour by working his soldiers excessively hard:

"...his own ideas of how to run his company was a little bit... SAS-ish shall I say."¹³

Such was the impact on the soldiers' morale (and consequently on their performance) that his company sergeant major attempted to advise the company commander to ease up,

“The guys were meeting themselves coming off [exercise]. There was no social life happening at all. It was all, bloody well cut and thrust and ‘Let’s go!’ and people were performing badly because they weren’t having time to recover... It was just bumping on from one bloody crisis to another. The company sergeant major advised him, and spoke to him about it but no, the company commander wasn’t having any of it. He was having it the way he wanted it. If the platoon commanders weren’t performing they were chopped off at the knees and thrown into the waste pile and get someone else along.”

Having failed to convince the company commander, the company sergeant major then approached the RSM and made him privately aware of what was going on. He first approached him in the sergeants’ mess and subsequently came to see him in his office.

“And then I [the RSM] went to the Commanding Officer the following day. I left it for a day, and went in to see the CO the next day rather than going in from now, straight into his office with the sergeant major going that way and the company commander getting called up there.¹⁴ ... The Commanding Officer ... played it quite correctly, so he then left a time, and then, either in the office or in the mess, whatever, he spoke [to him].”

A little later the sub unit commander became less intense in his requirements of his soldiers.

Analysis:

By over-stressing function, the sub unit commander was not allowing enough time for the *informal* and *loyalty/identity* structures to be exercised, and the soldiers’ morale was dropping. He had the balance wrong.

The sergeant major was able to approach his sub unit commander both because he was directly subordinate to him in the *formal command structure* and because he would have had at least *informal access* to him, if not a developing relationship of *association*. He also had responsibilities within the *loyalty/identity structure* for the reputation of the sub unit within the unit, and within the *functional structure* for the efficiency of the soldiers.

Once he had failed to convince the sub unit commander, the sergeant major brought the matter indirectly to the sub unit commander’s formal superior, the Commanding Officer. He did so by exploiting an informal relationship with the RSM (approaching him first in the sergeants’ mess), knowing that the RSM could approach the Commanding Officer either formally through his position in the *formal command structure*, or informally, using the relationship of

association with him. The CSM thus used the *informal structure* to overcome what he saw as a barrier in the *formal command structure*.

Whatever happened next is not recorded: the correction of a senior member of a unit is a delicate matter because, if handled badly, it can undermine his position in all four structures. In any case, it would have taken place in private. However, it is clear that it had the effect that the company sergeant major desired because the training pressure was lifted from the soldiers in his company. It should be noted that all this took place without the need for a public confrontation at any stage.

This analysis by the model clearly reveals the existence and importance of the various means of communication available through the informal relationships in the *informal structure*. It also shows us that the speaker, the RSM, saw no disloyalty on the part of the company sergeant major, indicating that it was accepted between them that, where there was a conflict, the collective interests of the soldiers came above the wishes of the sub unit commander.

Case Nine: the Missing Cannon Balls

This next informant, a Royal Engineer, was remembering an overseas tour when he was a junior NCO clerk:

“Not many people in our squadron liked the... I don't know what he was called... the Commander of the British Forces in the [overseas base]. And outside of his office he had eight cannon balls - three on the base, outside of his door, one on the top. And to get from our accommodation you had to go across the square, past his office to our squadron bar. ... I used to do Duty Clerks [24 hour duty] in the headquarters building. And one day the Commander's cannon balls went missing. And he guessed it was the Sappers that did it. I was on duty the night that they went missing. So he called me in, he said 'Find my cannon balls'. So he used me to get his cannon balls back, because he knew I was a Sapper. ... And I did. I didn't personally find them. Right, I got the word round the squadron that 'you'd better have the cannon balls back p.d.q. [pretty damned quick] otherwise the squadron's in deep shit.' ... I didn't know who had taken them. ... I was the vehicle to say 'Get those cannon balls back or we're in deep shit. The squadron's in deep shit - the OC downwards.' And they came back. So I was the vehicle but I never knew who... you see at the time I was also the squadron barman so I knew a lot of the people. I knew what was going on.”¹⁵

Analysis:

In taking the cannon balls, the soldiers were communicating their dislike of the Commander by exercising *informal revenge*. However, as in most cases of *informal revenge* the action taken was easily reversible but made the point clearly and anonymously.

The Commander reacted, also using informal means, by exploiting communications channels in the *informal structure* to get the cannon balls back. Rather than making an official complaint to the OC of the sapper squadron, he got his message round by using his relationship of *informal access* with one of the clerks who worked in his headquarters. It is likely that the Commander deliberately chose this individual for the task because he was also a barman in the squadron bar and therefore had a very good network of informal relationships and thus a quick and usable system of informal communications.

In passing on the implied threat of sanctions, the junior NCO was using the *formal command structure*. The soldiers reacted informally by replacing the cannon balls.

This case highlights four important aspects of British Army life. First, we see that all the actions took place using the conventions modelled in the *informal structure*, which indicates the widespread possibilities for individual and collective action provided by these conventions. It also indicates, as the previous case does, the existence of a many-branched set of informal communications available to all agents. Thirdly, it shows the nodal position of a comparatively junior individual, in this case a junior NCO, who has informal relationships both with figures of authority and with his peers. This individual had formal and informal links with the Commander British Forces, and loyalty/identity and informal links with his fellow Royal Engineers. Finally, we see again the availability of the *formal command structure* to a senior person as a potential resource: even though he never raised the stakes to formal disciplinary action the commander was able informally to issue a credible threat to do so.

Case Ten: A Quarrel in the Mess

The context for this incident was an evening in the officers' mess at a training camp in Germany. I was one of the three gun battery commanders in the unit that was under training, during a regimental firing camp¹⁶.

During the earlier part of the day, my battery had been firing under my direction for a helicopter-mounted observer, using ammunition allocated specifically for the training of that observer from a central training pool. A few hundred metres away one of my fellow battery commanders, Jim Stirk, was exercising his battery in a simulated operational scenario. Unfortunately, we had a very limited supply of ammunition overall and the regimental second-in-command, Paul Roberts, had decided that we would share it between us, ignoring the fact that much of it was supposed to be fired exclusively for the training of the helicopter-mounted observer. He had made this clear to Jim Stirk, but not to me, as he had been in a hurry to meet an appointment that was going to take him away from the regiment for a few days. Inevitably, as the ammunition dwindled, Jim and I had a disagreement over the radio as to who should use it.

In the officers' mess that evening, the atmosphere was tense, as two battery commanders had had a public disagreement. A third, Gerry Smyth, took the part of Jim and tried to upbraid me. Gerry was a technically highly proficient officer, selected for battery command at an early age, but he was hard to like because he was unambiguously ambitious and tended to become aggressive under pressure. I was not prepared to accept his criticism, and, angry as I was, I told him not to be silly, turned my back on him and ignored him. The atmosphere became yet more tense. The other officers said nothing and looked away, but it was obvious that they were waiting for the next development.

By now I had begun to realize that the problem was caused by Paul's failure to make the ownership of the ammunition clear, and Jim had acted in good faith. As Paul was not there he could not clear the matter up. In the mean time, we were all becoming more and more uncomfortable.

I resolved the situation by going over to Jim, apologising, and offering to buy him a drink. He accepted my apology and a normal atmosphere asserted itself in the mess.¹⁷

Analysis:

During the day, Jim and I had each acted in accordance with the importance that we had individually placed on our respective exercises, using the resources of the *functional structure* to inform our attitudes and actions towards the limited supply of ammunition. Had we been told the same thing about its purpose, we would have cooperated, but our perceptions were at variance.

Whereas we had been able to sustain our functional disagreement during the day, the officers' mess, a place where the *operating structure* was expected to be the *informal structure*, was an inappropriate setting in which to develop or prolong it. We all felt uncomfortable, which probably gave Gerry Smyth the

feeling that he ought to do something about it and prompted what I saw as his irritating intervention.

Even though I could see by now the real cause of the problem, I knew that it could not be resolved properly without waiting for Paul Roberts' return, which would be too late to prevent a build-up of resentment. After a little thought, I took the blame because it was clear to me that the losses involved in compromising an informal relationship of *friendship* with Jim were greater than the loss of face I would suffer in apologizing.

The peace offering of a drink was highly appropriate to the informal setting of the officers' mess, and it was well timed because it enabled Jim to co-operate in deflating our quarrel in an informal way.

The constant element of *superiority and inferiority* was evident in the lack of intervention by any of the other officers present in the mess, all of whom were junior to the battery commanders.

The main point that emerges from this analysis is the sharp and widely understood difference between the functional context, where disagreement was possible, and the informal context where disagreement was not appropriate.

Case Eleven: Disgraceful Behaviour

Whilst a unit was deployed on operations, the families' officer (a man commissioned after long service in the ranks) was, as is usual, left behind in UK. During the tour he had an extra-marital affair with the RSM's wife while her husband was away with the unit. This RSM had been brought in from another Regiment because none of the warrant officers in the unit had been judged to be suitable, and so he was viewed as an outsider. The behaviour of the families officer was considered to be inexcusable, and he was sacked: the interviewee who described the incident called it "a form of incest". The RSM left as well, according to the interviewee because he had lost his credibility with the sergeants' mess. This created a vacuum and the then TQMS [Technical Quartermaster Sergeant], one of the most senior warrant officers class 2 in the unit who had been passed over earlier, was given the post of RSM.

While the families officer and the RSM's wife were having their affair in UK, the Commanding Officer was having his own, open, extra-marital affair with a civilian aid worker. However, he was neither sacked nor punished. He served a full tour as Commanding Officer and was subsequently promoted. None of his officers or men spoke badly of him in interviews. One interviewee described

the Commanding Officer's marriage as in difficulties before the affair, and implied that his action had been very understandable.¹⁸

Analysis:

At first sight, this case has the appearance of a manifestation of the British class system, as a man who had seen long service in the ranks was punished whilst the Commanding Officer, who had committed the same moral offence, was not. However, this does not explain the removal of the RSM, an innocent party to his wife's adultery. This thesis's model of social structures provides a different and revealing axis of analysis, as follows.

- The unit had had to accept a man from outside its bounds as RSM. It seems probable that the *loyalty/identity structure* was taxed by this arrival of an incomer to such an important post. It is reasonable to conclude that he was vulnerable to rejection should the opportunity arise. His wife's affair provided the opportunity for the unit to reject him, using the reason that his position as RSM was compromised.
- Furthermore, as the RSM was an outsider, he would not have had the automatic personal support that might have come if he had a long standing set of relationships of *association* (and dormant *friendships*) with his sergeants' mess members and with the officers. What was expressed as his loss of credibility was therefore inevitable, and due more to his structural position as an outsider than to his personal attributes or competence.
- The appointment of the TQMS, a member of the unit who had previously been passed over for promotion to the position of RSM, fitted much more comfortably with the *loyalty/identity structure*.
- The families' officer had clearly abused his position of responsibility, as set by the *functional structure*, and it was very reasonable to send him away from the unit. Furthermore, his illicit relationship with a woman who was married to a member of the unit, albeit an outsider, was a gross violation of the conventions of the *informal structure* and the *loyalty/identity structure*.

- The Commanding Officer, on the other hand, had his affair with a woman who was nothing to do with the unit, and so there was no question of 'incest', or transgression of the *informal* or *loyalty/identity* structures. As a full member of the *loyalty/identity structure* of the unit, his soldiers were inclined to be open-minded and forgiving about his conduct.

Analysis using the model therefore demonstrates that, whatever other external forces were at work, the conventions represented in the *loyalty/identity structure* played a particularly important part in the acceptance by members of the unit of the different outcomes to the two extra-marital affairs, and the lack of personal support for the RSM may have been the product of his lack of long standing informal relationships in the unit. It also demonstrates the power of the model to work in complex and potentially highly charged cases.

Case Twelve: A Successful Amalgamation

Amalgamations are frequently difficult because they involve the sudden pushing together of *social structures* from different units. This, however, is a case where amalgamation went smoothly.

Two Royal Armoured Corps units amalgamated to form one unit during one of the periodic reductions in size of the Army. Knowing that successful amalgamations are difficult to achieve, the Commanding Officer of the new unit and his Second-in-Command together decided on the following measures:

- As both old units were being moved to a new barracks to form the new unit, there would be a deliberate change of unit identity for each person arriving at the new barracks. Each man would wear the special distinctions of dress of the new unit from the moment he arrived in the new barracks and the new name of the amalgamated unit was to be used from the first opportunity to distinguish it from the names of the two amalgamating units.
- There would be two amalgamation parades: one private one just for the members of the new unit and their families shortly after the new unit was set up, and a larger-scale public one rather later. Both parades were to emphasise both the new unit's identity and the new sub units' identities.
- The deployment of each individual was carefully managed so that every group, down to the four-man crew of a tank, contained at least one man from each of the two amalgamating regiments.

Beyond the control of the Commanding Officer, there was also a great deal of training to do, and a great number of military commitments. Most members of the unit reported that they had hardly ever been so busy.

The amalgamation was successful in that cohesion in the new unit was achieved quickly and with little difficulty.¹⁹

Analysis:

The Commanding Officer and his Second-in-Command carefully manipulated the *formal command, loyalty/identity* and *informal* structures of the new unit to give the best chance of achieving unit cohesion quickly.

- Making each soldier adopt the regimental distinctions of the new unit on arrival in the new barracks began the process of locating all the members in the new *loyalty/identity structure*.

- This process was enhanced by the strict use of the new regiment's name as early as possible.

- The two amalgamation parades exploited the flexibility of the *loyalty/identity structure*. The private one had a unifying effect downwards into the body of the unit and the public one proclaimed the identity of the new unit to the rest of the Army. In both cases the sub units' identities were enacted in the presence of the other sub units. Thus both unit and sub unit levels of the *loyalty/identity structure* were exercised.

- The deliberate mixing of soldiers from the two original units down to vehicle crew level meant that they had to unite in the *functional structure*, and it prevented rivalry between elements of the two old units.

- This process also ensured that the lower levels of the new *loyalty/identity structure* united soldiers from the different old units in the belief that their new groupings were 'the best'.

- It also meant the single private soldiers and single junior NCOs from the two amalgamating units were evenly mixed in the barracks accommodation. This mixing ensured the growth of informal bonding between members of the different old regiments. Essentially, therefore, a set of new relationships of *friendship* were created by manipulating the accommodation plot.

- The heavy task load, due to training and other commitments and the two amalgamation parades, exercised the *functional structure* of the new unit.

In this case, the careful manipulation and exercising of elements described in the model as being from all four *social structures* created a positive atmosphere in the unit, and the soldiers accepted the amalgamation more easily than many external observers expected.

This is a particularly interesting case because it very closely followed principles that could have been derived from the model: many elements modelled in each of the *social structures* were exercised and all were given particular emphasis at various times. However, the model was not available at the time and what was done had its origins purely in the military instincts of those who made the plans and carried them out. As the Commanding Officer subsequently said to me, “All we did was sit down and think it through from first principles.”²⁰ The fact that the plans fall so easily under the categories generated in the model is a strong indication therefore that it provides a good encapsulation of military instinct.

Conclusion

The foregoing section has demonstrated the model’s power to analyse soldier’s behaviour in a way that enhances our understanding and illuminates certain elements that might otherwise be difficult to detect. Not only does such an analysis help to identify some of the social undercurrents affecting their behaviour, but also it helps to explain events that flow against an external observer’s intuitive expectations.

SECTION FOUR: APPLICATION OF THE MODEL TO PREDICTING SOLDIERS’ BEHAVIOUR

This section takes this capacity of the model to explain soldiers’ behaviour after it has taken place onto a further stage by examining its ability to act as a tool for prediction of soldiers’ behaviour before it is known. It does so by providing the observer with the means to model the situation that he or she is observing, and its background, and then to make projections into the as yet unknown.

The model’s predictive power in the small scale interactions of life between soldiers at regimental duty should by now be obvious from the earlier sections in this chapter, and from Chapter Three. We may predict with confidence, for example, that a relationship of *association* is likely to arise between any adjutant and his chief clerk, that formal terms of address will be used on any particular parade, and that soldiers

who are *friends* will choose to eat together at their next opportunity. We may also say that it is likely that soldiers who are incompetent in their military skills will not have much prestige among their peers, and that an individual with many channels of communication at his disposal will use informal means in preference to formal means.

This section now goes beyond this general minor level and examines a small number of specific cases where the predictive power of the model was specifically demonstrated on the larger scale.

It must be understood that the number of specific larger scale predictions that I was able to substantiate is small because the scope and structure of my research precluded my checking of the accuracy of many of the predictions I made. There are two main reasons. First, I was not able to revisit the units where I had gathered interview material, so the outcome of most of the predictions that I made during these visits is not known. Second, the other data I have gathered were either gained before the model was sufficiently mature for predictions to be possible, or were gained outside the context of regimental duty when I was collecting recollections of past events, which precluded prediction.

Nevertheless, there are a small number of cases where I found specific large scale predictions confirmed, and these affirm the predictive power of the model.

Case Thirteen: the CO's Options for Correcting A Sub Unit Commander

Whilst building up scenarios to discuss with my informants, I generated an imaginary case of a sub unit commander (major) who would not listen to advice from his sergeant major, and persisted in making his sub unit work too hard. At the time I had no idea that I would come across an actual case for discussion (see Case Eight on pages 174 to 176). An important part of the scenario was the interview between the CO and the major during which the major was made to see the error of his ways. Such an interview would have been an important incident in the life of a unit (although it would be in private) because the correction of the behaviour of a senior member of a unit's management is a significant event. To make the case sound convincing, I used the four-structure model to generate from first principles possible options for lines of approach for the CO as follows:

- He could have disciplined the sub unit commander (*formal command structure*),
- He could have had a quiet but firm word with him, exploiting such factors as "the good of the battalion" (*loyalty/identity structure*) or "we've known each other for some time and I can see that something is

wrong” (*informal structure*) “or you have a job to do, and you’re getting it wrong” (*functional structure*).²¹

During the interview from which Case Nine is taken, I put these possibilities to the informant, whose reply is illuminating:

“I think you’ve covered the ways that it would go and that I would see it go.”²²

In this case I had used the model to produce a scenario that I had not experienced and from that scenario to derive from first principles what I saw as a plausible plot. In fact, I had generated a set of options that appeared convincing to an individual who had indeed been involved in just such a situation and who declared that I had correctly predicted the available options.

Case Fourteen: An Unbalanced Policy

The Commanding Officer of one of the units that I visited held strongly that the only thing that was important for his unit was function. He saw success and failure solely in terms of good military operational performance and the training that had to be done to achieve it. Having spoken to him, informed by the model, I noted that his approach was unbalanced in favour of the elements captured in the concept of the *functional structure*. I therefore predicted a decline in morale and performance in the unit because the soldiers were not being allowed time to exercise the elements modelled in the other three *social structures* to the same extent²³.

In a subsequent interview, an experienced officer who had observed this unit closely declared that their morale became ‘brittle’ in the year following my visit, and that although their peacetime performance had held up he would not have wanted to trust them on operations.²⁴ This view was confirmed by an officer of that unit who uncompromisingly said to me that morale was ‘low’ at the time he joined it, about a year after I had conducted my research and made the prediction²⁵.

This is a case where a simple prediction based on the model came true, unambiguously demonstrating its predictive powers. It is also an interesting confirmation of the fact that, as is clear from the model, military performance is more

than the product of training alone (*functional structure*) but also depends on the other aspects that are modelled in the other three *social structures*.

Case Fifteen: Behaviour Patterns of Soldiers Who Take Illegal Drugs

Drawing on the model, I predicted that if a soldier was indulging in behaviour that would meet with the disapproval of his peers then he would be unlikely to form *friendships* in the same pattern as other soldiers who did not behave in this disapproved of way, whatever it might be. He would be in a very small minority in the unit, possibly a minority of one, depending on the behaviour at issue.

I noted that the taking of illegal drugs (referred to hereafter as ‘drug abuse’) at regimental duty was considered unprofessional by all my informants who expressed an opinion on the subject. As a junior NCO put it to me clearly and to the point,

“Soldiers really do not like the feeling that they may have to rely on someone who might be whacked out of their minds.”²⁶

I therefore developed the original prediction into a further one, that those who take illegal drugs would tend to be shunned by their peers and seek out the few available like-minded individuals. Those individuals would form the core of their group of *friends* in that they would share a profound interest, trust each other, and look to each other for supplies of the drugs. Such like-minded individuals would be likely to be scattered at random within the unit, or indeed the garrison. Having observed that the majority of private soldiers’ and junior NCOs’ *friendships* were within the sub unit²⁷, I therefore predicted that private soldiers and junior NCOs who regularly took illegal drugs would form a higher than usual proportion of their *friendships* outside the sub unit.

There is a remarkable consistency in the interview material which I gathered after I made this prediction that confirms it. For example, a junior NCO told me,

‘that the drug using fraternity all share a close personal habit and that therefore form a close bond of friendship. Best friends share secrets. Drug abuse is a secret. Drug users will therefore form cliques. As drug abuse is rare they will therefore form cliques where they can find like-minded friends.’²⁸

and another junior NCO:

“[It spoils friendships] because I don’t want to know anybody that does drugs and I’m sure a lot of people... [are the same]. ... But a lot of people, whenever they smoke drugs they stay in a clique with certain people and them cliques become tighter and they go away from the group.”

“And would those cliques be from more than one company?”

“Yeah. Always.”²⁹

and

‘[From a group session of senior NCOs] They raised the question of drugs and social patterns. They said that drug misfits would gang together because they had shared interests.’³⁰

and from interview notes with a private soldier:

‘I asked about activities about which the other soldiers might disapprove, without being specific. He said that someone doing something disapproved of would find it difficult to make friends. In that case he would find a like-minded friend or friends outside the [sub unit].’³¹

and from an officer who had had to deal with a drug abuser in the rear party he commanded:

“...on the Rear Party, ... one was a young soldier from the Depot ... He made very few friends within even his own peers who came from the Depot with him. And he was hanging around people from other regiments.”³²

and from a conversation with an Guards RSM:

‘He told me that such people had few friends, only really like-minded individuals, and they formed a little group that was not based on a company.’³³

Some time after making the original prediction, having observed the increasing toleration of drug abuse in general British Society (especially among the young, the pool from which soldiers are recruited) I speculated about a situation where drug abuse might become something that was informally tolerated by the junior soldiers. I predicted that in that case there would be a strong tendency for the majority of drug abusers to take drugs out of the military context and to separate it from any activity that involved military training or deployment on operations.

My reason was that it was incompatible with the conventions of the *functional structure*.

I followed up these predictions in March 2001 by talking to an experienced member of the Royal Military Police who had been involved in investigating drug abuse for the past 15 years. He confirmed both of my predictions. In the first part of his service, the RMP investigators had used the pattern of ‘associates’ of suspected drug abusers as an axis of investigation, having discovered that the friendship patterns of such drug abusers tended to be along the lines I had predicted. But now that drug abuse was more widely tolerated in British society, the pattern had changed and a drug abuser’s associates were as likely to come from his sub unit as not. However, soldiers very seldom mixed drug taking with soldierly activity and drugs were hardly ever found on operations.³⁴

Conclusion

The predictive power of the model for the minutiae of soldiers’ lives is self-evident, and its power in larger scale issues has been demonstrated by these three examples. We may therefore say with confidence that prediction of soldier’s behaviour, both individual and collective is made possible by use of the model. At whatever scale, the model may be said to encapsulate what an insider would feel is likely to happen, and might therefore be used by either an insider or an outsider to gain insight into any situation within a unit and its likely outcome.

We will now explore the limitations of the model before we compare it with other models that cover soldiers’ lives at regimental duty.

SECTION FIVE: ASSESSMENT

The model has been shown to be capable of describing, analysing, and predicting soldiers’ behaviour. Furthermore, because of the rigour of the language of the special terms within the model and the model’s clear and simple structure, there seems to be every chance that different observers using it would produce similar descriptions, analyses and predictions.

This assertion has been supported by the reaction of the dozen or so military audiences to whom I have presented the model over the past six years and then offered cases for on-the-spot description and analysis. They found the model intuitive and easy to use. More significantly, every soldier to whom I have described the model,

including many of my interviewees (rank ranged from private soldier to major general), has said that it provides a good description of their lives at regimental duty.

However, as is the case with all models, this model can only provide an approximation to the ground truth and therefore has certain limitations which will now be examined. They fall into two main groups, those limitations that are to do with the model's boundaries, and those limitations concerned with its practical use.

Limitations to the model: boundaries

The first set of limitations concerns the definition of the boundaries of the model: what it includes and what falls outside its scope. First, it has an impermeable outer edge, in that it is bounded at unit level. Second, it does not deal very well with soldiers' behaviour which falls outside the typical pattern because it is focused on norms: collectively held attitudes and expectations and shared mental models of what is seen as natural and normal. There is an inherent assumption in the model that unit members will behave in ways that are consistent with the social structures. Specific areas of difficulty are discussed in the following paragraphs.

Outer edge of the model

First, as noted in Chapter One, this is essentially a 'zoomed in study'³⁵ that does not cover the wider context of events or individuals' social relationships outside the unit: it artificially treats the unit as a discrete and self-contained social element.

This limitation of scope is of course a feature of most models, which usually have edges as a matter of design to make them usable³⁶. However, these limitations have implications for this model which we need to acknowledge and assess.

There are many reasons why the unit can legitimately be considered as a discrete element for analytical purposes. Unlike many social groupings, military units have clearly defined physical and social boundaries, membership is unambiguous and the members both work and live together for extended periods of time during operational deployments and exercises. As Kier says of the US military, it 'creates an encompassing environment, integrated around collective goals and relatively isolated from civilian life'³⁷, thus echoing Goffman's observations about 'total institutions' which we visited in Chapter One³⁸.

There are, however, some areas of difficulty with this approach. While it may be legitimate to exclude general political and social events that take place outside the unit, it could be argued that the model has a weakness in excluding the external social and personal contacts that are part of the regular lives of the individuals who comprise

the unit. Those soldiers who have friends and family away from their place of duty correspond with them, talk to them on the telephone, and visit them during their off-duty time (and especially during their periods of leave). Furthermore, those soldiers who are living in married quarters combine their family lives simultaneously with exercising membership of their unit.

It can confidently be argued that the disregard of soldiers' more distant family and social links is perfectly legitimate, because these links hardly impinge on the contexts to which the model applies. However, the absence of engagement in the model with the families of married accompanied soldiers is harder to justify and must be accepted as a weakness in the model. Having accepted this omission as a limitation, it must be said that it has precedents in the social science literature on the British Army, for example:

'I would have liked to have written a chapter, or more, on the position of Army spouses and the parents of soldiers. Unfortunately my field work often centred on single soldiers and dealt with Army wives mainly from the perspectives of their husbands, which no doubt did not give an entirely balanced perspective. In the absence of better data, and additional space, I considered it fairer to leave the debate with Jolly's excellent discussion of the topic (1987/92³⁹).'⁴⁰

and no other model has yet been produced which manages the incorporation of this missing element.

This exclusion of married accompanied soldiers' families must be accepted as a limitation in the model, if a necessary one. An observer using the model should therefore bear this omission in mind and be on the alert for the possible influence of family matters.

Agency

Another area of potential weakness in the model is that it does not predict the effects of an individual's attitude and personal agenda. It is certainly possible to use the model to describe and analyse in retrospect the chain of events and the social relationships in a situation where an agent with a strong personality attempts to dominate a situation. However, the model has little capacity to predict if or when a strong-willed individual will choose to oppose the norms represented in the model or attempt to force the outcome of particular situations from a position of social weakness. Nor can it predict what will happen when they do. For example, in the following situation a private soldier (the narrator) has irritated his sergeant, George Simms, and the sergeant is attempting to resolve the situation unofficially. Their platoon is on a route march in an isolated spot and the sergeant is in charge, with Corporal Brown as his second in

command. There are no other troops around and the sergeant has reached the end of his tether with the speaker,

“He [Sergeant Simms] just said, ‘Corporal Brown, take the rest of the platoon on.’ And he and I stayed back and Brown took the rest of the platoon on and sort of three or four hundred metres down the track. I always remember George Simms saying to me, ‘So, you think you’re a boy do you? One of the boys? Put it there!’, and he was inviting me to hit him, and I was inviting him to hit me first.”

Comment: Although the situation could be described and analysed using the model, as an attempt to exert unofficial punishment (an *illegitimate secondary adjustment*), without knowing the individuals concerned it would be impossible for the model to predict what the outcome of this incident would have been because so much depended on the reaction of the private soldier. It was entirely dependent on his personal feelings whether he struck out or held back. Similarly, the sergeant’s subsequent response would depend on his own reaction to what the private soldier did. As it turned out, the private held back and sergeant was deprived of the opportunity to hurt him:

[Continuing] “I remember being quite cool, calm, and let the whole thing... Young as I was, and the short time I had been in the Battalion and I was sort of taking on this guy, you know, verbally, and in the end you know, he sort of clipped me round the head and said, ‘Right, let’s join the rest of the platoon.’ And off we went.”⁴¹

Similarly, the suite of informal relationships in the model does not allow for cases such as that alluded to on page 109 of Chapter Three, in which the mutual dislike of two parties exceeds the capacity of the control mechanisms described in the model. For example:

‘[The interviewee, a member of an armoured regiment] then told me about a certain QM(Tech) and a certain Squadron Leader [sub unit commander in an armoured regiment] who had fallen out. ... In this particular case, they had fallen out in such a big way that neither would speak to the other, and they had a very obvious mutual distaste for each other. This was exemplified in a shouting match on one particular exercise [presumably not a private affair]. This relationship was never sorted out, and only ceased to be acute when they were posted apart through the natural processes.’⁴²

A further situation which falls at least partially outside the model is that in which an agent deliberately absents himself from the military social structures. Consider this case, which is a summary of an interview I conducted with a private soldier while he was serving a sentence of detention in a unit guardroom for going absent without leave⁴³:

His personal life was “full of hassle” and he felt that it was all too much for him. He therefore decided to go AWOL and move in with his long standing girlfriend and their daughter in his home town [well away from his duty station]. He knew from his experience in the Army that almost all absentees either give themselves up or are recaptured in the end and so his absence was likely to be temporary. He also knew that his duties would have to be shared among the remaining members of his troop or platoon, and that it was a unit custom that they would therefore appropriate some or all of his military equipment to pay him back. Nevertheless he decided to go, and disappeared at the end of a period of leave.

His absence was reported to the unit Adjutant, who informed the Commanding Officer and put his name on a formal list of ‘absentees’. At the same time, the authorities in his sub unit asked his *friends* to try to contact him and persuade him to return.

During his absence he lived with his girlfriend and had some form of paid employment.

Analysis:

Some of what happened can be described with reference to the model:

- He decided to reject the authority of the *formal command structure*, though he knew that he would have to submit himself to it again at some stage in the future.
- He subordinated the claims upon him of the *loyalty/identity* and *informal* structures to his personal desires and obligations. He knew that this would confer an informal right on his room-mates to take items of his military kit (a *legitimate secondary adjustment*)
- He removed himself from the *functional structure*, in the knowledge that other people would have to perform his share of unliked jobs such as guards and fatigues.
- His superiors took appropriate formal (disciplinary) action, but then tried to use the *informal structure* to persuade him to return.

However, this is not a complete picture. The following factors outside the model probably also applied:

- Personal emotion towards his girlfriend and their daughter.
- The general acceptance of cohabitation outside marriage in British Society, but not at that time in the British Army, which forced them to live apart because they were not entitled to a married quarter⁴⁴.

- A psychological profile that allowed him to justify to himself his rejection of authority.
- Childhood experiences and upbringing that made him willing to subordinate military loyalty and duty to personal ties.
- The existence of agencies outside the Army who paid him a wage which allowed him to sustain himself and his household.

Finally, there is no room in the model for soldiers who habitually go beyond the boundaries of the ideas, rules, and conventions of their daily lives at regimental duty, or do not feel significantly affected or bound by them. For the purpose of this thesis, I have called such individuals *rogue agents*. Here we are not considering the effect in certain limited contexts of the attitudes and agendas of the agents present, but rather agents who normally consider themselves outside the norms, or are not sensitive to them. Here is an example from the interview material⁴⁵. The interviewee is a private soldier whom I described in my fieldnotes as:

‘Apparently unflappable and seemed gently amused by the whole experience of being interviewed.’

This is the way he described his attitude to the chain of command during a domestic crisis when he asked for help:

“I didn’t feel anti them - I’m not one of these people who’s anti authority - but I just thought, ‘He’s a guy, he’s a sergeant-major or he’s a captain or he’s a lieutenant colonel and ... he’s in charge’ and that’s really all I thought. My attitude was I didn’t like the way some people seemed to cower from authority. ... They treated a person differently just because of his rank.

Comment: He is not in awe of the *formal command structure*.

When I asked him if he felt he ever had to prove himself:

“No, I don’t feel I have to prove myself to anyone else but myself. ... I wanted to show myself that I could do my job a hundred percent professionally.”

Comment: He has his own personal version of the *functional structure*.

When I asked him if he felt that his sub unit was the best in his unit:

"[Dismissively] No. I’ve never felt that. It was just another [sub unit]. ... I feel I would have been the same in any other."

Comment: He does not subscribe conventionally to the *loyalty/identity structure*.

Of *friendship*:

“We’re sort of thrown together, for some reason there’s more... you might only meet a guy for two or three days and say ‘Could I borrow ten pounds?’ and he’d say ‘Sure, and you can give it back tomorrow’. That wouldn’t happen outside in civvy street. But I don’t think it has that same depth. There’s a lot more back-stabbing goes on, ... people criticising and slagging each other off.”

Comment: an idiosyncratic appreciation of *friendship*.

Such a man is so free from the influence of what I model as *social structures* that the model could not be used with confidence to describe, analyse or predict his behaviour.

Addressing the difficulties

A useful tool for summarising these limitations in the model may be drawn from the work of Ulf Hannerz, which we briefly reviewed in Chapter One⁴⁶. It will be recalled that he produced a table summarising the field of possible origins of human ‘modes of thought’, and thus behaviour, and that these fields encompassed ‘inherent aspects’ (modes of thought with which human beings are born) and ‘developed’ aspects (modes of thought that were acquired through the process of culture).

As pointed out in Chapter One, it proves extremely difficult practically to assign particular elements of behaviour with any confidence to the ‘inherent’ or the ‘developed’, but they are nevertheless useful as conceptual categories. Hannerz numbered the resultant six cells in his table from 1 to 6, but without assigning any significance to the numbers concerned. For ease of reference, this table and the associated notes from Chapter One are reproduced here:

	INHERENT	DEVELOPED
INDIVIDUAL (idiosyncratic)	1	2
ENDURING COLLECTIVES	3	4
UNIVERSAL (panhuman)	5	6

Table 4.1 Hannerz’s Conceptual Table of Culture

Notes to Table 4.1 (summarising Hannerz):

1. ‘Inherent’ means in this context ‘Biological in origin, and part of the human nature’.

2. 'Developed' means 'acquired in the course of experience. Not biological in origin'.
3. 'Enduring Collectives' mean 'large-scale cultural groups in which the individual spends the majority, or all, or his or her life'. An example would be 'British society'.
4. The numbering of the boxes is for reference only, and does not imply any relative importance.

This table can be adjusted to make Hannerz's general conceptual model specifically relevant to the present study. The adjustment consists of the insertion of a new row, entitled 'temporary collectives', defined as social environments in which individuals spend a significant proportion of their lives and which can be expected to provide a forum for the generation of particular ideas, rules and conventions of behaviour. Because individuals enter, pass through, and leave these 'temporary collectives' those individuals are significantly affected by them, though not to the same extent that they are influenced by the constant background of what Hannerz calls 'enduring collectives'. By this typology, we would categorize the Army as a 'temporary collective' and adjust the table thus:

	INHERENT	DEVELOPED
INDIVIDUAL (idiosyncratic)	1	2
TEMPORARY COLLECTIVES	3	4
ENDURING COLLECTIVES	5	6
UNIVERSAL (panhuman)	7	8

Table 4.2 Hannerz's Conceptual Table of Culture (Adjusted)

We may now use this adjusted table to address the status of the model conceptually, without seeking to assign particular detailed elements of soldiers' lives or behaviour to any specific box. Our purpose in so doing is to use the categories in the table to throw into clear relief those areas where the model does, or does not, contribute to understanding the totality of the lives of soldiers and by doing this we may unambiguously identify its limits.

It is readily apparent from consideration of this table that the model presented here is focused mainly on the modes of thought and behaviour which fall in boxes 3 and 4 insofar as they pertain to regimental duty in the relevant temporary collective (the British Army), and makes no attempt to differentiate between inherent or developed elements. We may also conclude that any behaviour or mode of thought that falls outside those two boxes may not be so well covered by the model.

The table shows clearly and concisely that there are likely to be significant elements in the lives of soldiers that might indeed fall outside those two boxes, and thus acts as a prompt not to ignore them in the analysis of soldiers' lives. In the first place, the table encourages us to observe that the behaviour of soldiers will be at least partially informed by elements that fall logically into boxes 1 and 2, as this is the arena of individual agency. Where an individual's attitudes and assumptions conform to the expectations captured in the four *social structures*, we can say that, as far as these boxes are concerned, he appears well integrated into military life. However, where it does not, then his actions or attitudes set him apart from the conventions captured in the model, and he is a *rogue agent* whose behaviour is not going to be effectively analysed and predicted using the model.

Secondly, we must accept that there is likely to be some influence on soldiers' behaviour from boxes 5 and 6, their non-military cultural background and origins, which, again, is not captured in the model. An obvious example is the effect of the regional or national origins of individual soldiers which can lead to the formation of groupings that are not predicted by the model. Fellow Scotsmen, for instance, or fellow West Indians, may join together to support their national team against England in front of the television in the NAAFI, irrespective of their *loyalty/identity* affiliations in the unit.

We may use this adjusted table, therefore, to express clearly the boundaries of the model by saying that it focuses on boxes 3 and 4, has some capacity to deal with material that falls naturally into boxes 1 and 2, but does not directly encompass aspects that would fall into boxes 5, 6, 7 and 8.

It remains to assess the significance of these boundaries. On the one hand, it could be said that they are significant because they limit the scope and power of the model to capture the totality of soldiers' lives, and that a fully effective model would have to encompass all eight boxes. On the other hand, it must be accepted that a fully effective model might well be impossible to create, would be highly complex, and, because of its complexity, may well prove unwieldy even if it were produced. Furthermore, as we have seen demonstrated in Chapter Three and the early part of this chapter, the current model has significant practical utility in describing, analysing and predicting the behaviour of most British soldiers in the context of their unit.

A reasonable conclusion, therefore, is that the model may be used with confidence, provided that the person using it is aware of the possible range of factors which fall outside it and keeps alert for their influence. As established in Chapter One (pages 23 to 27), the model is neither more nor less than a tool, a means to target ethnographic inquiry and to inform ethnographic analysis, not an ethnography in itself, and it is up to the researcher to use it intelligently and sensitively. Having said that, we

may make a fair assumption that the vast majority of factors that will emerge from participant observation of British soldiers will be amenable to analysis using the model.

Limitations to the model: difficulties in use

The second main area of difficulty is in the practical use of the model. Two particular issues stand out: determination of the *operating structure*, and the model's observer-oriented perspective.

Determination of the operating structure

The first difficulty with using the model is that it is not always possible to determine the *operating structure* unambiguously.

One of the model's basic assumptions is that there can only be one *operating structure* at any one instant, though this structure can change from moment to moment. However, there are occasions when the behaviour of soldiers might be ascribed to more than one structure. Take, for example, soldiers going forward in the assault. As I have shown elsewhere⁴⁷ elements modelled in all four structures are at work in propelling the soldiers forward: they are obeying orders (*formal command structure*), they are with their friends (*informal structure*), they are doing the ultimate soldier's task (*functional structure*), and they have the honour and reputation of their sub unit, unit, and capbadge in their hands (*loyalty/identity structure*). An observer seeing these men advance upon the enemy would be hard pressed to decide which of these structures was the *operating structure*.

In the light of such situations it may seem unrealistic to insist upon the modelling of one single *operating structure* at any one instant, no matter what the context. However, I do so, for the following two reasons. First, this assumption in the model reflects a very high proportion of my observations: soldiers' behaviour does pass through several *social structures* over short periods of time as the context changes. Refer to the very typical illustration on page 80 of Chapter Three, for example, when the soldiers' behaviour changed from the *informal structure* to the *formal command structure* and back again in the course of a few moments. Second, the concept that there can only be one *operating structure* encourages the observer to seek and identify moments of transition and thus to detect subtle changes in context. This is illustrated in the behaviour that I observed during the events of Case Six above. When the soldiers started playing the party games that were part of the boisterous celebrations of the battery's identity, I observed that the participants' behaviour underwent a change: they wanted to win and started to concentrate on the bizarre and unfamiliar task in hand.

Their behaviour thus changed from the conventions of the *loyalty/identity structure* to the *functional structure*, albeit in a thoroughly jovial and amusing way.

Generally, therefore, my experience has shown that there are considerable analytical advantages to this element in the model, which encourages the observer to detect what might otherwise be invisible ingredients of the situations that he or she is observing.

Nevertheless, it must be accepted as a limitation to the model that, as in the case of the troops in the assault, it may not always be possible to identify which is the *operating structure* at any precise instant. In practice, I have found that a useful way to treat such ambiguous contexts is to consider that, although there can only be one *operating structure* at any single instant, sometimes the *operating structure* is changing so rapidly from instant to instant as to become analytically blurred. This process is analogous to the apparent blurring of the blades of a rotating propeller: the speed of their rotary movement makes them appear as an homogenous disc, whilst in fact the blades remain separate solid objects.

I have called this the question of *simultaneity*.

An observer's perspective

A second difficulty in using the model is the fact that it is drawn from the observer's point of view, rather than that of the agent. The observer uses it to differentiate between *social structures*, and uses the terms in the model to describe and analyse informal relationships. However, that is not to say that individuals' subjective perceptions of their of experiences and actions necessarily fit the structures, even if their behaviour follows the lines that it predicts. There is therefore a potential dislocation between the observer's and the individual's perspectives that might conceal organisationally or personally important factors. This is a manifestation of the difficulties presented by the approach via social structure which we examined in Chapter One (pages 11 and 12).

In use, therefore, it is to be remembered, once again, that the model provides a tool for the observer, to be applied sensitively and critically to the data, rather than a direct route to a complete account of soldiers' lives.

Nevertheless, having noted that the model does not necessarily capture an individual's subjective perception, it must be repeated that all soldiers who have seen it have said that it was a very close approximation to the lives that they were experiencing. It rang true. Indeed, it was said by senior NCOs on a number of occasions that it would have been considerably more useful to them than the management training that they received as part of their military education for

promotion. The reason that they usually gave for this observation was that the model depicted the practicalities of their lives and its human challenges more clearly and accurately than the abstract management models that they had to learn.

Conclusion

It is clear therefore that the model is not without limitations. It draws artificial boundaries around the material it covers, there are some practical difficulties in the fine detail of using it, and it may not capture the individual agents' subjective experience because it is drawn from an observer's perspective and is aimed at norms.

These limitations, however, by no means invalidate the model as a tool for the social scientist who studies the combat arms of the British Army. They are the sort of difficulties that are inherent in modelling: a model can never capture the complete ground truth, as we saw in Chapter One (on page 22). At most, these limitations are warnings that point to areas where analysis may be unreliable, and an observer who checks against gross error in these areas may use the model with confidence.

We will now turn to other models to see if they can improve on the capabilities and limitations of the one proposed here.

SECTION SIX: OTHER MODELS

The purpose of this section is to compare this model of *social structures* in the combat arms units of the British Army to others which might be applied to the same area, all of which have been introduced in Chapter Two. They are those of Janowitz, Hockey, von Zugbach, and Stewart.

Janowitz: primary groups

The first of these models is that of Janowitz, in his chapter on 'Primary Groups and Military Effectiveness'⁴⁸. Although the majority of his research material came from the American Army, and he specifically considers soldiers in combat, he implies throughout the book that his conclusions are capable of being extended to other armies, which therefore would extend its legitimate use to the British Army.

Taking the concept of the 'primary group', the small face-to-face group of soldiers that live and work together, Janowitz models cohesion within this group as depending on four factors:

‘First, the technical dimensions of the weapons systems impose limitations on stability and cohesiveness in military primary groups. ... While generalizations in this area are most hazardous, it does seem that weapons systems which maintain close physical proximity of team members and enhance the process of communication contribute most to primary group cohesion.’⁴⁹

Second, the type of unit organization, including the personnel replacement system of the U.S. military establishment, has certain consequences for group cohesion that are worthy of study. ... When men do not know each other, combat units suffer in effectiveness. ... There is a further theoretical consideration. Primary groups are by definition a system of informal interpersonal relationships. Their value lies precisely in their independence of formal organization.⁵⁰

Third, social cohesion in primary groups is influenced by the proximity of danger and the importance of the mission which the group is assigned. ... Fourth, social cohesion in combat or under conditions of stress or extended alert depends on the performance of small unit leaders.’⁵¹

This analysis is undoubtedly useful as far as it goes. There is no question that small face-to-face groups have considerable potential for cohesion, and Janowitz has identified important factors in promoting and maintaining that cohesion. However, his model is not adequate to explain all cases of group cohesion, which can go far above the small, face-to-face case that Janowitz explores. This point may be demonstrated by examining the cohesion of the battery in Case Six earlier in this chapter.

Without doubt, the battery in Case Six displayed strong signs of cohesion, to the extent that their ‘battery spirit’ was noted by members of the other batteries, each of whom felt in their turn that they belonged to the ‘best’ and rejoiced in their own battery’s identity. However, the conditions in a British gun battery do not measure up to Janowitz’s model very well.

Although the technical dimensions of the individual equipment manned by members of the battery may well have contributed to the bonding of the small teams that operated them, if the battery is considered as a whole this is not the case. The technical dimensions of the weapons systems employed by the battery required that it be divided into three separated components when it carried out its military function. As is normal operational custom in a British field battery, the command element and the associated observer parties had been working separately, deployed forward and out of sight from the group associated with the guns. Similarly, the logistic element had usually been deployed to the rear of the gun group to be involved in moving and supplying ammunition.

The primary groups that existed in British artillery batteries in general, and this battery in particular, were therefore dispersed. It could thus be deduced from Janowitz's model that in these conditions any bonding at battery level would be correspondingly weaker than at primary group level. Such a deduction would, however, fail to take account of the situations when a battery was celebrating its identity as a battery *per se* (as in Case Six) rather than as a collection of primary groups. On the other hand, the *loyalty/identity structure* in my model does allow for identity and bonding to be transferred, according to context, between different levels in a unit.

Janowitz's second point is really two: that turbulence, resulting in soldiers not knowing each other, lowers the effectiveness of units; and that primary groups consist in informal interpersonal relationships that are independent of formal organisation.

The first of these observations integrates well with my model. A major component of the *informal structure* is interpersonal relationships, and if the soldiers do not know each other then it could be expected that the bonding element of this structure would not be well established.

I take issue, however, with the second. As far as the British Army is concerned Janowitz's analysis is correct in observing that the informal relationships between soldiers are not under formal control, but it is not the case that, as he claims from his research, they are independent of formal organisation. As we established in Chapter Three, informal relationships are constrained in many ways by the social elements modelled as the other *social structures* in a unit. For instance, differences or equivalencies in rank determine the appropriate relationship (be it *friendship*, or *association* or *informal access*), and informal relationships usually arise only between individuals who are in the same sub unit, or share membership of the same mess, or come into contact at work in some other way. Furthermore, it will be recalled that the field from which in individual's *friends* can be drawn changes as he progresses through the ranks (Chapter Three, pages 110 to 112).

It was not possible properly to explore Janowitz's third conclusion, that danger and the importance of the mission enhanced social cohesion, as most of my research was carried out in peacetime conditions. However, what indications that did appear in the research material would suggest that he is perfectly right.

For similar reasons, it was not possible to research the effect of the conduct of small group leaders in combat, though, once again, Janowitz's conclusions seem to integrate with the small amount of material that I gathered in this area.

Although, therefore, Janowitz's model may have considerable utility in examining the interactions and bonding in small groups in combat, the model presented in this thesis provides a better means to address the wider canvas of the totality of life

in a British military combat arms unit and provides an altogether more comprehensive and more elegant means of addressing the question of small group bonding. In particular, Janowitz's analysis omits two key areas that are closely involved in group bonding in the combat arms units of the British Army: the effects of the other *social structures* upon the *informal structure*, particularly the influence of the *formal command structure*, and the influence of the *loyalty/identity structure* without which, we may confidently say from the material presented in Chapter Three, any consideration of bonding in British units would be incomplete.

Hockey: Squaddies

Killworth has already made a lengthy critique⁵² of the Hockey's work⁵³. This subsection covers much of the same ground, using case material from my research to confirm it in the context of this thesis.

In 'Squaddies', Hockey presents a dualistic model of 'us' and 'them'. 'Us' are private soldiers, the 'squaddies' of his monograph, and 'Them' are everybody else, including NCOs, officers, and civilians. He also draws a clear analytical distinction between 'official' and 'unofficial' behaviour, which reflects my characterisation of 'formal' and 'informal' behaviour. For instance, 'There was a constant interplay, and often a resultant tension, between behaviour which was official and that which was unofficial in terms of organizational goals.'⁵⁴

One of the key theoretical concepts in his descriptions of private soldiers' lives is 'negotiated order', which is the result of tension between 'official' and 'unofficial' goals.⁵⁵ In his thesis this is the process by which the authority figures routinely do not make the lives of the soldiers too unbearable provided that the soldiers co-operate (and vice versa). However, he makes the point that even here the formal authorities have the ultimate say: 'the area(s) of negotiations, the bargains that are made, broken and reformulated, have limits which are set by the power held by superiors.'⁵⁶

At first sight, much of the data that I collected seems to contain various versions of 'negotiated order'. Take, for example, Case Ten, the 'missing cannon balls', which we have already examined: the soldiers did not like the Commander; they removed the display cannon balls to irritate him and give him the message that they did not like him; although the Commander had the power to complain formally and thus to make the soldiers' lives difficult for them, he made an unofficial threat through the clerk/barman who was my informant, and the cannon balls were returned. This certainly could be

taken as an example of a polarisation between the soldiers and the Commander, and the indirect nature of his threat implies a process of negotiation.

In a similar vein, an interviewee (a private soldier) told me of an occasion when the private soldiers in his infantry company rebelled at an overbearing order, but rebelled within the letter of the regulations. There was to be an all-ranks company Christmas party to which the Commanding Officer had been invited. Someone in authority in the company, presumably the sergeant major or the company commander, had decided to make attendance at the party compulsory and to lay down in orders that the soldiers should wear 'best dress' [i.e., to appear smartly dressed in civilian clothes].

"What actually happened was it came out on the Daily Detail as a 'Scale A' parade [compulsory attendance], which put some peoples' backs up... especially a party, a social do. 'Best Dress', and there was actually dress requirement. What the blokes did was basically lift the v's [make figurative 'v' signs] to that one and turned up in drag. A lot of them turned up in all sorts ... Because the CO was turning up as well - I think that was why the dress situation was laid down. But in the event it was a great evening."

Interviewer: "Did any of the soldiers get into trouble?"

"No they didn't."

Interviewer: "Was it accepted as being a permissible comment on the situation?"

"I think so, yes Sir."⁵⁷

Here again, soldiers are pointing out forcefully that those in authority had overstepped the mark in their heavy use of official channels, and Hockey's model can be used to explain that the private soldiers' act of defiance was part of the process of negotiation between those with formal power and those without.

However, although Hockey's work captures certain aspects of the military life reasonably well, it does not give a complete picture, and its dialectic opposition of privates to 'the rest' is too stark to reflect the complexities that I have found in my research.

First, Hockey does not allow for any relationships between private soldiers and what he sees as authority figures. In contrast, we have already noted in Chapter Three that *friendship* is possible between private soldiers and junior NCOs, and we have also seen the importance of the vertical, rank asymmetrical, informal relationships (*association* and *informal access*) throughout the unit. For instance, there is no room in

Hockey's model for relationships such as the one described here in my notes from a discussion between myself and a private soldier (a 'squaddie'). We were discussing the relationship between him and the RSM of his unit, arguably one of the most formally distant people in his working environment:

'I asked him about his view on the RSM. He was most reluctant to answer this question, but after some gentle pressure from me he said that he had disliked him until he became the staff car driver, after which he got to know him through chatting in the staff car and he now thinks that he is a good bloke.

Comment: Here we have a bond of *association* being formed and adding another strand to their relationship which had previously only been through the formal command structure.'⁵⁸

In Hockey's model, the only relationship that would be possible between them would have been rank-driven opposition, mitigated by some form of negotiated order. In fact, the relationship was considerably closer than that.

If we return to the case of the missing cannon balls, we will see again that Hockey's model cannot be used adequately to explain in detail what took place in the process of returning the cannon balls to their proper place. According to my analysis the events were only made possible because the Commander had an informal relationship with the junior NCO clerk through whom he could communicate to the soldiers who had taken them. He had no formal or official power to order such a junior person to get the cannon balls back, and the clerk would not have had sufficient formal power to investigate the theft. If the Commander had chosen to go through formal channels it would have had to have been through the Royal Engineer Squadron Commander, and not through a junior NCO. Whilst, therefore, it would be difficult to describe or analyse these events purely in terms of opposition and negotiated order, my model provides a workable means to do so, as we have seen.

It might be said in defence of Hockey's model that the clerk was a junior NCO and therefore not a 'squaddie'. The clerk was therefore one of the 'Them' and not one of the 'Us'. This would bring us to the second major observation about his model. In polarising private soldiers from the rest, Hockey is compressing the rank structure from junior NCO to Commanding Officer in a single category. All those with rank are contrasted with all those without rank. This denies the range of informal relationships that exist between superiors and inferiors throughout the different rank levels, the various forms and expressions of *informal access* and *association*. Elements of this range are laid out, for example, in my observations about the changes that come to a soldier's informal relationships as he rises through the various grade of NCO (see Chapter Three, pages 125 and 126). We may see a particular manifestation of this

difficulty if we revisit Case Five, in which a sergeant major corrected my behaviour when I was a lieutenant using *informal access*. Hockey's model has no power to analyse such an interchange because both the sergeant major and myself are simply part of one entity, 'Them'.

Third, Hockey treats the private soldiers as if they form a discrete group and are therefore fixed in time and space as privates. In fact, as we saw in Chapter Three, many individuals are promoted and follow a trajectory that includes several different positions and ranks in a unit. All senior NCOs and some officers start as private soldiers. This dynamic is entirely missing from 'Squaddies', and may well be due to his very brief periods of fieldwork (three separate visits which came to three months in all⁵⁹).

Fourth, what I have called the *loyalty/identity* structure is not present in his analysis, except perhaps a general consideration of membership of the infantry. Whereas the *formal command structure* is described, though in a perhaps over-rigid form, and the *functional structure* appears (though he does not seem to allow any room for development and change in the area of soldierly function), and so do some of the aspects of the *informal structure*, there is virtually no mention of regimental or sub unit identity, or of the cross-rank bonding that is achieved by common membership of a *loyalty/identity segment*.

Take this extract from my field notes, for example, part of which was quoted earlier on page 133, in which an infantry private soldier is speaking of his sub unit:

[Enthusiastically] "Charlie Company's the best company in the battalion. ... 'Cos it's the best bunch of lads and that. The lads are brilliant you know. They're good, and all the platoon sergeants and all the full screws [corporals] are good ... If you work with them, they'll work with you all the way, you know."⁶⁰

Hockey's model of the negotiated order might help to inform an analysis of the final statement: the support of the authority figures is conditional on the soldiers' willingness to work with them. However, it does not contribute to any understanding as to why the individual thought that his company was the 'best'. In contrast, my model of the *loyalty/identity structure* indicates that all soldiers in that battalion could be expected to think that their company was the 'best', and indeed it predicts that each soldier would be likely to believe that all the elements to which he belonged are better than any equivalent segment, as in this example, which is from an interview with an soldier in an armoured regiment:

‘He feels that his squadron is superior to the other squadrons. HQ Tp [his troop] is the best in the squadron, because it has the best drivers and best gunners in the squadron’.⁶¹

and this one, which is my own analysis of the feelings of the soldiers in my battery when I was a subaltern on operational duty in Northern Ireland:

‘We feel that 203 Battery [with whom we worked closely] are not as good as us, but they are reasonable to work with, but that 204 and 260 Batteries [other batteries in the regimental group] are well below our standard. Nothing much happens in their areas and they are not very good at what they really have to do. However, next door 407 Medium Regiment [another artillery regiment] break rules patrolling and therefore regularly endanger their men’s lives; while the Blankshires’ [an infantry battalion] security is unbelievably lax’.⁶²

In summary, Hockey’s model presents too stark and hostile a portrait of soldiers’ lives. Although it may provide insight into those contexts where the private soldiers are grouped together in opposition to figures of authority, such contexts by no means account for the majority of time spent by soldiers at regimental duty. As for ‘negotiated order’, I find myself in agreement with Killworth’s comments that ‘Hockey’s model of the negotiated order has been shown to rest upon a division between formal and informal orders that is, in practice, confused and uncertain.’⁶³ I would further add that it takes too little account of the other elements that comprise the rich complex of ideas, rules and conventions that inform soldiers’ behaviour. My model, in contrast, provides a considerably better tool with which to address the lives of soldiers at regimental duty.

von Zugbach: *Power and Prestige*

von Zugbach’s primary concern in *Power and Prestige in the British Army*⁶⁴ is to show how those elements are not distributed evenly. The elements in this case are the different regiments and corps, and the agents who enjoy this power and prestige are the officers, and in particular those who reach senior rank. His work is therefore focused well above unit level, which is the analytical ceiling of my research, and is entirely focused on commissioned officers.

However, in building his case, von Zugbach produces a model of a unit⁶⁵ which appears to come close to the one presented in this thesis in that he differentiates different ‘sub-systems’ within the unit which have a *prima facie* resemblance to the *social structures* of my model. These sub-systems are the ‘Formal, Organisational

Sub-System', the 'Technical Sub-System', and the 'Informal, or Sentient Sub-System'.

These sub-systems comprise a system in which all parts interact.

He describes the 'formal organisational subsystem' as existing

'in a quasi tangible form in the shape of an organisation chart which expresses the organisational structure of the unit⁶⁶ in terms of a classical Weberian hierarchy of appointments (Weber, 1947)⁶⁷. This is supported by a more formal document, known as the Unit Establishment, which specifies the numbers and ranks of its members, together with the equipment to which the unit is entitled. The formal sub-system represents an ideal type communication pattern. It is the system by which orders are passed and, in its attendant maxim of "procedure through the correct channels" (meaning access to a higher superior, only through the individual's superior) it represents the pattern of vertical communication which is both formally recognised by system procedures and is assumed to operate, by individuals acting within the system, to the exclusion of other patterns of communication (Blau, 1955)⁶⁸. ... [The] formal organisational system impinges itself upon the everyday inter-actions [*sic*] of system members in respect of virtually every interaction that they make within the system'.⁶⁹

This is very close to the *formal command structure*, in that von Zugbach has made the same observations as I have about the sub-system being the vehicle for the definition of the structure of the unit, and its capacity to define formal communications channels. Furthermore, his observation that the 'formal organisational sub-system' impinges itself upon the everyday interaction of the unit members comes close to one of the elements of the permanent thread of *superiority and inferiority* noted in Chapter Three.

He describes the 'technical sub-system' as representing

'a bridge between the formal, organisational sub-system and the sentient sub-system. The formal system is concerned with the way in which the unit is formally structured, on the other hand, [*sic*] the technical sub-system relates to what is done in the unit and how this is to be done. While the structure of this sub-system is less immediately visible to the observer than is that of the formal sub-system, the influence of the technical sub-system is all-pervasive in the operations of the unit.'⁷⁰

At first sight, this element could be mapped on to the *functional structure*. However, his 'technical sub-system' is focused on the use of function (what is done in particular units) to differentiate types of unit: infantry; armoured corps; engineers; artillery, and so on. It is therefore more to do with matters of identity than ideas about, and attitudes to, military functions *per se*. Thus he ascribes to his 'technical sub-system' some of the aspects that I have ascribed to the *loyalty/identity structure*. Furthermore, by using technical matters as his only axis of differentiation he omits the

very large number of other ingredients which are included in the concept of the *loyalty/identity structure*, and in particular the continuation of feelings of identity below unit level down to the lowest organisational segment. Thus it overlaps two of the social structures in model presented in this thesis without addressing the fine detail of either.

The 'sentient sub-system' 'represents the sum total of the values, assumption [sic], expectations, "Kleinweltanschauungen" and conceptions of self, upon which unit members draw for the development of their every-day patterns of action and consciousness'.⁷¹

Here, again, this 'sub-system' shares some features with my model. In particular, it overlaps my construction of the *loyalty/identity structure* and the *functional structure*, but it does not differentiate between the importance of attitudes to *loyalty/identity segments* and to soldierly tasks, which are different in content and quality.

Thus far, these differences almost certainly reflect the different purposes of the two models we are comparing and probably represent a different arrangement of compatible ideas. Von Zugbach's is for use in identifying and separating different parts of the Army, whereas mine is for use in examining soldiers' behaviour within individual units.

However, there is a major area missing from von Zugbach's model, without which any analysis of a unit would be incomplete. He does not cover is what is modelled here as the *informal structure*. Although he mentions relationships between officers and men, it is purely in the context of the 'technical sub-system' to show that different technical sub-systems breed different attitudes in the officers.⁷²

Even in this restricted context his analysis does not ring true when compared with one arising from my model. For example, he seeks to show that officers in the Royal Armoured Corps form close bonds with their soldiers because they have to share the tasks of crewing a tank with them, while 'in the infantry, on the other hand, such interactions are conducted at distance and in terms of formal orders from superior to subordinate'⁷³. Using the model presented in this thesis, we can quickly see that there are two difficulties with this analysis.. First of all, he underplays the importance of the wide-ranging processes and attitudes that are captured in the *informal structure* as a whole, and secondly he has missed the significant opportunities for bonding between officers and men that exist in the infantry, some of which we visited in Chapter Three when we considered the *informal structure*.

Let us confirm these observations by comparing the power of von Zugbach's model to analyse two of the cases we have already examined, in this instance Case

Eight, the 'difficult sub unit commander' (pages 174 to 176), and Case Ten, 'a quarrel in the mess' (pages 177 to 179).

Case Eight shows a significant difference in quality between the two models. Using von Zugbach's, we could explain that the sub unit commander was using the resources of the 'formal organisational sub-system' to impose his will upon his soldiers in making them work hard. His CSM's attitude to this overworking of the soldiers was informed by the 'sentient sub-system' in that he had values and standards against which to judge his company's commander's actions. The model also could be used to say that the action he subsequently took was in accordance with the 'sentient sub-system' in the unit.

On the other hand, useful though this analysis may be, it will be readily apparent that it does not approach the depth that the model presented in this thesis provides. Specifically, it does not provide the language for the fine grained analysis of the CSM's informal relationships with his company commander or the RSM, nor does it provide the predictive framework for the CO's conversation with the company commander discussed in Case Fifteen.

Case Ten demonstrates further how wide the gap is between the two models. von Zugbach's model could be used to discuss the ingredients of the live firing exercise, which would be part of his 'technical sub-system' but it would not be capable of describing or analysing the nature and strength of the informal relationships that existed between myself, Gerry Smyth and Jim Stirk. Nor could it be used to explain the significance of the change in context between the live firing exercise and the officers' mess, or the mechanism whereby Jim and I co-operated in deflating our difference.

Although von Zugbach's model, therefore, has a resemblance to the model presented in this thesis, this resemblance is superficial. We have seen that it cannot be used with the same precision to describe, analyse, and predict soldiers' behaviour in combat arms units of the British Army. This is not to say, however, that von Zugbach's is necessarily a poor model. It is as well to remember that it was not generated to cover the minutiae of life at regimental duty but to act as a basis for arguing for differences in power and prestige between the Regiments and Corps in the Army, a purpose for which it appears to be reasonably well suited.

Stewart: unit cohesion in the Falklands War

Stewart examines unit cohesion during the Falklands War in both Argentine and British land forces, using as her framework a model of four analytically separate elements:

‘In sum, military cohesion consists of three major elements:

1. Relationships between peers (horizontal).
2. Relationships between subordinates and superiors (vertical).
3. Relationship to the military as an organization or unit (organizational).

But we cannot examine the soldier solely on the micro or small-unit level and ignore the social, cultural, economic, and political heritage of his nation. Therefore, I include a fourth type of bonding:

4. Relationship of the military and the individual to the society or culture at large (societal).⁷⁴

She attributes the structure of this model to ‘work done at the U.S. Army Research Institute for the Social and Behavioral Sciences’⁷⁵, drawing particular attention to the work of Siebold and his associates⁷⁶.

It is clear from her text that, as far as British forces were concerned, her research was mostly confined to members of the Royal Marines and the Parachute Regiment, though she interviewed members of all arms in the Argentine Army. This seems to have weighted her comments and analysis to the concerns of the infantry. This does not by any means invalidate her research, but it is as well to bear it in mind when assessing its significance.

The area that her model covers is broader than Janowitz’s (which concerns small face-to-face groups only) and Hockey’s (which examines the soldier’s life through a lens which pits private soldiers against the rest), and von Zugbach’s (which almost entirely considers officers). A particular strength in her model is that it can be applied throughout a unit, encompassing all its members, by treating horizontal and vertical bonding as separate but simultaneous axes.

There are many similarities in the elements of cohesion that she identifies and the ingredients of the *social structures* in my model. For example, she shows in her description of ‘vertical bonding’ that relationships and interaction between officers and men are important considerations, thus addressing areas covered by the *informal structure* and her analysis of ‘organizational bonding’ captures many of the features drawn out in my description of the *loyalty/identity structure*. It is certainly the closest model to mine of the four under discussion in this section, and presents fewer difficulties than the other three in use as a tool with which to describe life in a combat arms unit of the British Army. However, although they are fewer these difficulties are significant.

First, a significant difficulty arises with her insistence on including the ‘societal’ element as a force for bonding at unit level. In her chapter covering this area⁷⁷ she considers such widely different factors as national attitudes to the military,

the national defence budget, training, doctrine, tactics, logistics and supply and medical care. All these elements most certainly have an effect on combat capability and may thus be indirect contributors to morale, but she does not make the case convincingly that they contribute to unit cohesion in their own right. In effect, therefore, only the remainder of her model (the vertical, horizontal, and organisational axes) should be used as a direct comparator to mine, and we will proceed on that basis here.

Taking these three axes alone, I find four further significant difficulties with the analysis presented in her book. The first is that her outsider status is all too obvious from time to time. This is manifested in several minor errors. Examples of such errors include references to a British army regiment she calls 'the Blue Jackets'⁷⁸ [in fact a historic term for members of Royal Navy⁷⁹], an appointment in the Royal Marines called 'Command Sergeant Major'⁸⁰, neither of which exist, and her identification of the Commanding Officer of the Commando Logistic Battalion, Ivar Helberg, as a Royal Marine⁸¹, when he was in fact an Army officer⁸². These mistakes are probably harmless, in that they are not related to the main thrust of her analysis, but they raise doubts in the mind of the informed reader and cast suspicion on the depth of her research.

There are, however, areas where her outsider status counts more significantly against her. An obvious example is her analysis of the Regimental System, which is uninformed. She says for example that 'a particularly salient factor in the regimental system in the British Army as a whole is a lack of personnel turbulence. Men train, work, and fight together for years and years.'⁸³ This is a picture that is often presented to outsiders by members of the infantry and Royal Armoured Corps but it is not a true one. The majority of soldiers in the British Army is in fact trickle posted as individuals (see Chapter Three, page 98 and note 37), and even in those parts of it where the men stay in their units there is considerable turbulence due to the normal turnover of recruits arriving, soldiers leaving, and postings to the regimental depot and other military establishments such as training units. Indeed, she herself quotes the Commanding Officer of 42 Commando as saying that the average age of his soldiers was under twenty⁸⁴ - hardly possible for men who had spent 'years and years' together because the minimum age for enlistment at the time was seventeen. I believe that she formed this misconception because all thirty of her interviewees were from either the Royal Marines or the Paras⁸⁵, who may be expected by the conventions of the *loyalty/identity structure* to sing the praises of the system to which they belonged.

In this respect, it would be more satisfactory to say, using my model, that a particularly salient factor in the British Army system is not so much the regimental system but rather that *loyalty/identity segments* provide a highly effective axis for bonding because of the shared conventions described by the *loyalty/identity structure*.

It will be recalled that by these conventions everyone who belongs to the operating *loyalty/identity segment* is a full member of the group, no matter what their status. This is illustrated by the example given on page 136 in Chapter Three, in which Royal Engineers soldiers took care to look after a newly joined member of their troop. In spite of his low status as fresh from initial training, they embraced him into their troop by looking after him when he was unprepared for a short-notice exercise deployment: they did not want people outside their troop (the operating *loyalty/identity segment*) ridiculing him and, by extension, their troop. There was no question of any of the protagonists in this case having served together for a many years: not only was he new to the unit but none of the fellow-members of the troop could have served together for even as much as three years because the Corps of Royal Engineers are all trickle posted on two to three year tours.

On the one hand, outsider status can be a strength, as we reviewed in Chapter One (pages 28 and 29), as it confers 'stranger value' on a participant observer by which he or she can detect things that insiders would not notice because they appear so natural to them. However, this is not fully relevant in this case as Stewart was not a participant observer, but was restricted to interviewing soldiers who had returned from the campaign. Her errors of fact indicate that she probably did not know the background of her interviewees as well as she might have done, and as well as I knew the background of mine, and was therefore less able than I was to understand the implications of what they were saying or to make judgments on what may have prompted it⁸⁶.

My next difficulty is in the way that she has separated 'horizontal' and 'vertical' bonding. Although this provides a workable pair of axes for analysis, day to day life in the British Army incorporates a continuous mixture of vertical and horizontal interaction, and, as I have shown in Chapter Three (pages 152 to 154), the background is permanently coloured by considerations of *superiority and inferiority*. It would be better, therefore, to put both vertical and horizontal ingredients together in the same elements of a model, and to differentiate the different processes in which interaction - both vertical and horizontal - takes place, as I have done with the *informal structure*, the *functional structure*, and the *loyalty/identity structure*.

Thirdly, she combines elements to do with personal relationships and function in the same axes of bonding, for example the 'sense of mission' and 'technical and tactical proficiency' along with 'trust, respect, and friendship' into horizontal bonding, and 'trust and respect for leaders' and 'sharing of discomfort and danger' and 'shared training' into vertical bonding⁸⁷. Whilst there is a clear connection between these two areas in the realm of personal prestige and mutual respect, as we saw in Chapter Three (page 113), I believe that it is better to place an analytical distinction between attitudes towards function and towards personal relationships because this distinction provides a

finer grain set of analytical categories. Indeed, in some instances individuals may have high functional capability and prove their functional worth in training and on operations but be disliked by their peers. This is exemplified by peer attitudes to the ambitious subaltern in Case Eight and to Gerry Smyth in Case Eleven: both were highly proficient officers whose military abilities were not questioned by their peers but neither of them were trusted very much by those peers because of their aggressive ambition.

A fourth problem is that she puts more emphasis on patriotism and loyalty to the nation and its values than is justified for the British Army⁸⁸. Factors such as these may indeed show up in the British Army as a matter of identity when there is an immediate comparator. British soldiers will of course compare themselves with those they perceive as foreigners when it is appropriate, and particularly when they are in an operational setting where the local population or the enemy are not British. However, this is a long way from saying that the political heritage of the nation is the bonding force within a British military unit which Stewart implies. I suggest that in almost all circumstances more immediate factors are more important than national bonding, and that when 'Britishness' does appear to be an axis of bonding it is analytically more effective to regard it as the broadest category of the *loyalty/identity structure*.

This view is supported by the quotations we have already seen at the head of Section Four of Chapter Three (page 91), which say bluntly that British soldiers do not consider their membership of British society or their commitment to the government of the day to be as strong a bonding force as the presence of one's peers. Further weight in this specific context is given by a company commander in the Falklands War, who has said in public that men do not die for Queen and Country, but they ultimately die for the respect of their friends.⁸⁹

This should have shown up in Stewart's analysis because she tells us that she collected data that indicated it:

'Even though he may give an offhand answer to an eager military sociologist with her questionnaire - an answer that shows indifference to politics - the soldier on the ground is concerned with issues of just and unjust war, or the Geneva Conventions, or international politics. But these feelings are on a deeper level than we usually assume in a questionnaire or an interview.'⁹⁰

It seems that she has made an assumption here that is not supported by her data, and one which I would not have anticipated.

This is not to say, however, that Stewart's model is so deeply flawed as to be useless. Many of the problems that I have described in her analysis of British soldiers in the Falklands War can be explained by considering the purpose of her work. Her aim differs from mine in that she carries out a comparative study between armies whilst mine is to describe the elements of daily life specifically in a combat arms unit in the British Army. This means that her model has to fit the general case, whilst mine needs to be focused on a specific one. Viewed in that light, her model is highly suitable for its purpose, as she shows in the coherence of her comparative analysis of the British and Argentine soldiers. The problems come from apparent shallowness in her research about the British Army and Royal Marines, and from the apparent temptation to force both Argentine and British forces into giving equal weight to all the parts of her framework. A pertinent example of the latter is the question of organisational bonding which we have just addressed. The evidence she presents for patriotism among the Argentine soldiers and marines is strong and interesting: the difficulty arises in her attempt to wish the same sort of feelings on British troops without the necessary evidence. In this particular respect, her analysis could have shown up the interesting fact that in this domain the nationalistic and patriotic elements of organisational bonding were stronger among Argentine forces than the British, and that this indicates different patterns of cohesion.

In summary, Stewart's model is superior to the other three models discussed in this section because it is capable of being used throughout a whole unit. However, probably because of its general comparative purpose, it remains undifferentiated in certain key areas that are identified in my model and that represent important aspects of British soldiers' lives at regimental duty. It does not therefore go as far as mine in terms of analysing the minutiae of British soldiers' lives and would be a less precise instrument in the task of describing, analysing and predicting their behaviour, though it remains a useful instrument for comparative analysis between military forces.

SECTION SEVEN - CONCLUSION

In this chapter we have examined the application of the model in its purpose of describing, analysing and predicting soldiers' behaviour at regimental duty, considered its limitations, and compared it with other models created to apply to the British Army. We have concluded not only that it is fit for its purpose, provided that the limitations are acknowledged and kept in mind during its use, but also that no other published model competes successfully with it for that purpose.

The next chapter presents the testing of the model against historical data from the British Army.

Notes to Chapter Four:

¹ See Chapter One, pages 41 to 42.

² Hockey, J., *op. cit.*, 1986.

³ Killworth, P., *op. cit.*, 1997.

⁴ Summary of Fieldnotes, 23 September 1994.

⁵ Recollected incident, 1983.

⁶ Hockey, J., *op. cit.*, p. 56.

⁷ Killworth, P., *op. cit.*, 1997 p. 114.

⁸ Recollected incident, 1972, when I was a lieutenant.

⁹ Recollected incident, 1986.

¹⁰ 'Reporting chain' is a phrase used to describe the hierarchical series of ever more senior officers who write on an individual officer's annual confidential report. In the case of a subaltern, as here, the chain would normally include at least a brigadier and if he was regarded highly enough then a major-general as well. Other senior officers outside this reporting chain might be expected to have an indirect influence on the report.

¹¹ Fieldnotes, 1 October 1974.

¹² Fieldnotes, 17 August 1974.

¹³ All the quotes in this case study come from Fieldnotes, 3 February 1994.

¹⁴ This means that the RSM left a time interval before going to the CO so that nobody would connect the visit of the CSM with the RSM's subsequent visit to the CO.

¹⁵ Fieldnotes, 25 April 1994.

¹⁶ 'Camp' is used here in two senses. In the first instance it means a physical location, the 'training camp', and in the second it means a functional activity: to take part in a 'regimental firing camp' means to participate in collective training lasting (at that time) for about four weeks and consisting of several exercises, some of which involved live firing of artillery equipment.

¹⁷ Personal recollection, 1985.

¹⁸ From Fieldnotes, 23 September 1994.

¹⁹ From Fieldnotes, 26 April 1994. This material is the product of interviews with the Commanding Officer, the Second in Command and seven other members of the unit rank ranged from private soldier to captain.

-
- ²⁰ Personal communication, 4 August 2001.
- ²¹ Fieldnotes, variously dated. I used this scenario on several occasions.
- ²² Fieldnotes, 3 February 1994.
- ²³ Fieldnotes, 17 March 1994.
- ²⁴ Fieldnotes, 22 June 1998.
- ²⁵ Fieldnotes, 24 November 1999.
- ²⁶ Fieldnotes, 14 July 1994.
- ²⁷ See Chapter Three, page 97.
- ²⁸ Fieldnotes, 3 August 1994.
- ²⁹ Fieldnotes, 21 April 1994.
- ³⁰ Fieldnotes, 25 July 1994.
- ³¹ Fieldnotes, 26 April 1994.
- ³² Fieldnotes, 19 August 1994.
- ³³ Fieldnotes, 9 March 2001.
- ³⁴ From Fieldnotes, 16 March 2001.
- ³⁵ See Chapter One, page 30.
- ³⁶ Wilson, B., *op. cit.*, 1990 , p. 316.
- ³⁷ Kier, E., ‘Discrimination and Military Cohesion: An Organizational Perspective’, in M. Katzenstein, F., and J. Reppy (ed.), *Beyond Zero Tolerance: Discrimination in Military Culture*, New York: Roman & Littlefield Publishers, Inc., 1999, pp. 25-52., this p. 29.
- ³⁸ See Chapter One, page 20.
- ³⁹ Jolly, R., *Military Man Family Man: Crown Property*, London: Brassey’s Defence Publishers, 1987 and Jolly, R., *Military Man Family Man: Crown Property*, London: Brassey’s (UK), 1992.
- ⁴⁰ Killworth, P., *op. cit.*, 1997 p. 12.
- ⁴¹ Fieldnotes, 19 August 1994.
- ⁴² Fieldnotes, 26 April 1994.
- ⁴³ From Fieldnotes, 14 January 1994.

⁴⁴ This aspect is now (2002) less firm than it was in the early 1990s. Under certain circumstances the CO may now issue a licence for cohabiting couples in his unit to occupy married quarters if he wishes to.

⁴⁵ All the quoted material from this interviewee comes from Fieldnotes 18 February 1994.

⁴⁶ Hannerz, U., *op. cit.*

⁴⁷ Kirke, C., *op. cit.*, 2000, p. 235.

⁴⁸ Janowitz, M., *op. cit.*, 1965, pp. 77-99.

⁴⁹ *Ibid*, p. 81.

⁵⁰ *Ibid*, p. 84.

⁵¹ *Ibid.*, p. 85.

⁵² Killworth, P., *op. cit.*, 1997. See, in particular pp. 44-52.

⁵³ Hockey, J., *op. cit.*

⁵⁴ *Ibid.*, p. 142.

⁵⁵ This concept is introduced in *ibid.*, p. 9, and forms an important part of the theoretical stance throughout the book.

⁵⁶ *Ibid.*, p. 9.

⁵⁷ Fieldnotes, 8 February 1994.

⁵⁸ Fieldnotes, 31 March 1994.

⁵⁹ Hockey, J., *op. cit.*, p. 1.

⁶⁰ Fieldnotes 27 December 1993.

⁶¹ Fieldnotes, 26 April 1994.

⁶² Fieldnotes, 1 September 1974. All unit and sub unit identities have been replaced by fictitious ones.

⁶³ Killworth, P., *op. cit.*, 1997, p. 54. For the full critique of Hockey's model see pp. 45-59, *passim*.

⁶⁴ von Zugbach, R., *op. cit.*

⁶⁵ The unit level model is set out in *ibid.*, pp. 14 to 35.

⁶⁶ See the examples in Appendix D.

-
- ⁶⁷ von Zugbach cites Weber, M., *Wirtschaft und Gesellschaft*, Berlin, 1947.
- ⁶⁸ von Zugbach cites Blau, P., *The Dynamics of Bureaucracy*, Chicago, 1955.
- ⁶⁹ von Zugbach, R., *op. cit.*, p. 15.
- ⁷⁰ *Ibid.*, p. 15.
- ⁷¹ *Ibid.*, p. 15.
- ⁷² *Ibid.*, pp. 36-47.
- ⁷³ *Ibid.*, p. 45.
- ⁷⁴ Stewart, N. *op. cit.*, p. 27.
- ⁷⁵ *Ibid.*, p. 26.
- ⁷⁶ For example, Stewart cites Siebold, G., *Bonding in Army Combat Units*, Paper presented at the Annual Meeting of the Southern Sociological Association August 28-September 1, 1978, New York, Oliver, L. *The Relationship of Group Cohesion to Group Performance: A Research Integration Attempt*. Working Paper LMTA 8707. Alexandria, Va: U.S. Army Research Institute for the Behavioral and Social Sciences, 1987, and Furukawa, T. *et al*, *Evaluating the Unit Manning System, Lessons Learned to Date*, Washington, D.C.: U.S. Army Division of Neuropsychiatry, Department of Military Psychiatry, Walter Reed Army Institute of Research, 1987.
- ⁷⁷ Stewart, N. *op. cit.*, pp. 54-80.
- ⁷⁸ *Ibid.*, p. 37. This appears to be a misunderstanding for 'Blues and Royals', a Household Cavalry Regiment that deployed a troop to the Falklands War.
- ⁷⁹ Pearsall, J., (ed.), *The New Oxford Dictionary of English*, Oxford: Clarendon Press, 1998, p. 194.
- ⁸⁰ *Ibid.*, pp. 118 and 144. This is probably a misunderstanding of the meaning of the acronym 'CSM' ('Company Sergeant Major).
- ⁸¹ *Ibid.*, pp. 60 and 120.
- ⁸² Army List, Part III Biographical, London: HMSO, 1983, p. 371.
- ⁸³ Stewart, N. *op. cit.*, p. 35.
- ⁸⁴ Stewart, N. *op. cit.*, p. 101, citing Vaux, N. *March to the South Atlantic: 42 Commando Royal Marines in the Falklands War*, London: Buchan and Enright, 1986, p. 232.
- ⁸⁵ Stewart, N. *op. cit.*, pp. 144 and 145.
- ⁸⁶ The further advantages of my status as an insider were discussed in detail in Chapter One, pages 30 and 31.

⁸⁷ Stewart, N. *op. cit.*, pp. 27 and 28.

⁸⁸ See for example, Stewart, N. *op. cit.*, p. 80.

⁸⁹ Brigadier I R Gardiner RM, unpublished lecture script, *Some Realities of Command at Company Level in War*, Royal Military College of Science, 25 May 2000.

⁹⁰ Stewart, *op. cit.*, p. 81.

CHAPTER FIVE - TESTING THE MODEL IN THE HISTORICAL DIMENSION

SECTION ONE - INTRODUCTION

The purpose of this chapter is to test the model in an environment that is close enough to that for which it was developed but distinctive enough to present a different arena in which to examine it.

The need for testing is an important characteristic of the use of models, as we considered in Chapter One (pages 5 and 6), to assess their degree of rigour and to explore the limits of the simplifications or assumptions inherent in them. To test a model, we need to search for areas where it breaks down or where it presents a distorted picture: in testing, we are probing to the point of failure to assess the implications of that failure for the future use of the model.

The Research Questions

The research questions used in this chapter aim to explore whether the model presented in this thesis has sufficient internal rigour for the analyses that it provides of contemporary British soldiers' behaviour to be considered valid and useful. A comprehensive test would involve changing both the organisational milieu to which the model is applied and the time period. To that end, I carried out initial research in three areas, a unit of the contemporary United States Air Force, a contemporary Gurkha unit of the British Army, and the British Army of previous time periods, from the mid twentieth century back to the seventeenth century. However, it became clear during this initial work that, while each could provide sufficient case material for the testing of the model, together they presented too large a research field for a single thesis. Accordingly I selected the third area, the historical British Army. This was a personal decision, based principally on the accessibility of first hand accounts of life in that context through available published material compared to my opportunities for further access to serving members of the Gurkhas or the US Air Force.

The chosen environment for the test therefore remains life in the British Army at unit level, but rather than the contemporary setting in which the model was derived we are going

to examine its suitability in historical contexts. It is a fundamental assumption within this test that there have been sufficient changes in unit life over the span of the historical periods selected to provide a sufficiently diverse range of contexts for the test to be valid. This seems a reasonable assumption given the considerable changes in British society, and in battlefield technology and tactics.

The test questions used in this chapter are:

1. Does the model set out in Chapter Three reflect the behaviour of British soldiers from the mid twentieth century back to the mid seventeenth century?
2. Are there significant aspects of the behaviour of British soldiers of the past that are not revealed or illuminated by the model?

A positive answer to either or both questions will indicate that the model has been tested to the point of failure. Such failure, together with its previously demonstrated capacity to explain, analyse, and predict the behaviour of present day British soldiers in combat arms units, would indicate that the model has both sufficient rigour and power to be valid.

The method

It is self-evident that there is not enough space here to test every part of the model through the entire history of the British Army and its seventeenth century antecedents. A choice had to be made as to the elements of the model to be tested and the historical periods in which to conduct the tests. The final selection was a balance between those for which a thread of historical continuity might be expected and those that seemed likely to show clear differences from the British Army of today.

This selection is as follows:

For Test Question 1 (must the model be modified for use in the different periods?):

From the *formal command structure*, the apparatus of rank and discipline, and the formal division of the unit on a clearly defined hierarchical pattern.

From the *informal structure*,

The existence and practice of *legitimate* and *illegitimate secondary adjustments*.

The existence and practice of the five-fold informal relationships of *close friendship, friendship, association, informal access* and *nodding acquaintance*.

These particular areas have been chosen for two reasons: first, they currently pervade all parts of a unit, and are available to all ranks in any combination in a unit; and secondly they are closely connected with the workings of discipline, power and status which may be expected to have undergone change over the past 350 years as Britain has moved from a more to a less authoritarian and stratified society.

From the *loyalty/identity structure*, the concept of belonging to several organisational levels simultaneously and the attitudes and feelings displayed by the individuals towards those organisational levels.

From the *functional structure*, the existence of a distinct set of mental models concerning, and attitudes to, soldierly tasks, as depicted by the model.

A choice of particular historical periods was made to provide data points in the continuous history of the British Army and its immediate antecedents. These data points had to be sufficiently far apart to provide bases for significant comparisons, but close enough together to minimise the likelihood of major developments being missed in the analysis. The final selection (going backwards in time) was:

Mid twentieth century (mainly the Second World War)

Early twentieth century (mainly the First World War)

The mid nineteenth century (mainly the Sikh Wars, the Crimean War and the Indian Mutiny)

The wars with France at the end of the eighteenth century and the early nineteenth century (mainly the Peninsular War) and shortly afterwards, for convenience referred to here as the 'Napoleonic period'

The mid to later eighteenth century (mainly the War of the Austrian Succession, the Seven Years War, and the American War of Independence)

The mid seventeenth century (mainly the English Civil War)

For Test Question 2 (does the model fail to reveal or illuminate significant aspects of unit life?):

Two social elements from the nineteenth century and earlier were selected, the concept of personal honour and the practice among officers of duelling. These two aspects of life in the British Army show up in the literature as powerful forces in motivating behaviour in the past, and must therefore have had a significant influence at unit level.

From a later period, the social implications for combat arms units of the large scale and comparatively sudden expansion of the British Army during the First World War were chosen. This expansion altered the Army's social composition and can safely be assumed to have had an effect on life at unit level.

The material

The material used to test the model mostly comprises extracts from published first hand accounts written by British soldiers of all ranks, as described and assessed in Chapter Two (pages 67 to 70). In the few cases where the individuals were serving in the army of the East India Company, I have only included material relating to interaction between British personnel. Such material seemed to have a substantial similarity to that generated by members of the British Army (unlike interaction between British and Indian personnel), and its inclusion increased the number of sources available.

These published first hand sources were supplemented by some unpublished material, chiefly from my collection of the 'unrecorded heritage' of the Royal Artillery which was described in Chapter One (page 40).

I used first hand accounts as the axis for this research because it most closely resembled the interview material and personal observations from which I built the model. This material seemed more appropriate than other options, such as the official contemporary records of daily life provided by, for example, Court Martial papers and order books, important and informative though they are.

There is nevertheless a profound difference between the material presented in Chapters Three and Four (which I either experienced myself or collected in person from informants) and this historical material. Whereas my material was collected in times of quiet and in barracks (apart from my field notes during operations in Northern Ireland), the bulk of the historical material records times of war. This is the result of a natural process whereby authors and their publishers were more inclined to make their experiences available to the public when there was public interest in what they were reporting than when there was not.

Accounts of daily life in peacetime tended not to provoke sufficient interest to allow them to survive or be put into the public domain.

On the one hand, this difference might be considered so significant that there are little reasonable grounds for comparison. It could well be said that the experiences of peace and war, the unthreatened barracks compared to the field of danger, are so far apart that they represent different domains of human experience altogether.

On the other hand, it is my contention that the same basic social processes underlie both cases. In Bourdieu's terms, the *habitus* (see Chapter One, page 14) that has been ingrained in the soldier in times of peace and in training for war before actual combat is still with him when he enters the deadly context of the battlefield. Furthermore, it is the common experience of the soldier of all eras that he spends the vast majority of his time not in combat: it is soldiers' lore that even in time of war life is largely boredom, waiting for something to happen, with a very small proportion of the time consumed in the fear and confusion of combat.

The position taken here is that it should be assumed at the outset that it is possible to apply the model to both peacetime and wartime contexts and let the differences, such as they are, emerge in the resulting analysis.

In general, the first-hand literature about life at unit level for the more recent periods is abundant but becomes progressively more sparse in earlier time periods. As Chandler says of contemporary sources in his introduction to a memoir of the War of the Spanish Succession:

'Inevitably, the further back in time the military historian delves the greater the problem of finding valuable contemporary sources - and yet these are vital requisites if any breath of life and immediacy is to be added to scholarly analyses of distant events.'¹

Whilst sufficient useful material does exist, albeit in small shreds, from even the earliest periods covered in this chapter for the limited task of assessing the model against it, it must be understood that from the later eighteenth century backwards this material is very sparse indeed. As far as rank and file are concerned, for example, there are very few published mid eighteenth century sources which can contribute to the testing the model, with one standing

out as of exceptional use in this context. This is the Journal of Corporal William Todd², its usefulness lying in its unusual length and in the way that it chronicles in such detail the everyday events of peacetime as well as war³. We will therefore see a disproportionate number of instances taken from his journal. The seventeenth century material is represented by but a few letters and memoirs, mostly written by officers, and much of it is aimed either at justifying the author to the new political order after the Restoration or at recording large scale events rather than the everyday business that the model addresses.

It was necessary to make a selection from the available material for use in this chapter. In general I found myself, at least from the Napoleonic period onwards, in what is a familiar position of difficulty to those seeking to provide detail from the broad sweep of history, as expressed by McGuffie in the Introduction to his work on the British Army: 'On the whole, however, the chief difficulty has been one of selection, both between books and between extracts.'⁴ In this study it was perforce a matter of personal choice. In making this choice my only practical guide was to search for descriptions of events that contain a substantial element of social content (a necessary feature for the testing of a social model).

There is also the question of quantity of examples and cases. In a study that covers over 300 years the amount of material that could be brought forward for consideration is prodigious. I have therefore restricted myself to the production of a small number of extracts from the material for each point in each time period. The reader should be aware that this is generally representative of a much larger sample, at least from the mid eighteenth century.

Quoted material is given in the spelling of the published version, which is usually that of the original document. Where unpublished sources are used, they are in the original spelling.

Caveat

There has been a constant temptation in writing this chapter to go beyond its purpose and to try to use the model as an analytical tool with which to examine the historical material. Although some analytical observations are forced into the light by the processes in this chapter, it must be remembered that our purpose is to test the model, not to use it at this stage. Use of the model on historical material is explored in Chapter Six, where many of the questions apparently left open in this chapter are addressed.

SECTION TWO - TEST QUESTION ONE: DOES THE MODEL REFLECT THE BEHAVIOUR OF BRITISH SOLDIERS FROM THE MID TWENTIETH CENTURY BACK TO THE MID SEVENTEENTH CENTURY?

In this section we will examine the applicability of the chosen elements of the model to soldiers' behaviour in the historical periods specified above. To maintain a consistent approach, the order in which we examine the *social structures* will be the same as in Chapter Three (*formal command, informal, loyalty/identity, functional*). We will proceed backwards in time for each structure because in that way we will be moving progressively further from the familiar ground of the present.

In giving the ranks of the individuals who are quoted below, as far as possible I have used the rank in which the author is speaking. For the most part, this means the rank at which he wrote the material if it is a diary or a letter or his final rank if he is writing memoirs.

The epigraph to each section comprises short selections from soldiers' songs of various periods, indicating a thread of preoccupation with some of the issues in each structure.

The formal command structure

*'Fifty [lashes] I got for selling my coat,
Fifty for selling my blanket'*⁵

*'For there's going to be an inspection in the morning,
And the Battery Sergeant Major will be there'*⁶

The existence of a formal command apparatus throughout all the period needs scarcely to be argued. A formally sanctioned rank structure and a system of discipline go back further than the earliest period considered here (see, for example, the work of McNeill⁷, and Bellamy's entry in the Oxford Companion to Military History⁸). Indeed, the statement by Lance Bombardier Spike Milligan that 'It's not too difficult to become a military criminal. Not shaving, dirty boots, calling a sergeant "darling"'⁹ could have been made by a British soldier at almost any time in the Army's history, and probably for a considerable period before that.

The testing ground from the *formal command structure* in the model is the existence and nature of the apparatus of rank and discipline and the formal division of the unit on a clearly defined hierarchical pattern. According to the model, this structure defines the lines of official responsibility and the chain of command above and below each individual. It contains a written code of discipline, badges of rank, symbols and attitudes that express power and authority, and an expectation of the obedience of the junior that is shared by all.

Establishing that such a description fits the cases of the British Army in the mid and early twentieth century and the mid and early nineteenth centuries would be superfluous, and there will be no attempt here to prove this obvious point. Given the passage of years since the eighteenth century, however, it seems unsafe to make any assumptions in that period, so we will begin the test in that era and work backwards to the mid seventeenth century.

At first sight, the rank structure of the British Army of the mid to late eighteenth century had elements in it that are unfamiliar today: we read, for example, of ranks such as 'mattross'¹⁰, 'captain lieutenant'¹¹, and 'sub-brigadier'¹². However, the system of rank structure was in most important respects the same as the current situation. There was the same distinction between those who held the sovereign's commission and non-commissioned

officers, and between non-commissioned officers and private soldiers. The generic design of a unit organisational structure would be familiar to a soldier today: the Commanding Officer had a small number of officers directly beneath him in his headquarters, including an adjutant and a quartermaster, and his unit was formally divided into subunits (companies for infantry and troops for cavalry), each commanded by an officer¹³.

There was a written code of discipline, the Articles of War¹⁴, which were, *inter alia*, the legal basis for formal Courts Martial, and which were backed up in particular cases by orders by the local commander, as described in this example, by Mattross James Wood in his diary entry of 29 November 1759. He quotes from 'General orders', setting out a new organisation and deployment of the artillery in his garrison in India and the duties and responsibilities of the King's and East India Company's artillery:

'The officer commanding each bastion is strictly to examine into the state of the guns, carriages, ammunition and all other necessaries belonging to the bastion under their charge and are to be answerable that everything is at all times fit for immediate service. ... An orderly sergeant of the King's and Company's artillery is to visit the different bastions and ramparts occupied by their corps every morning before the relieving of the guards and to report to their proper Commanding Officers who is [*sic*] to report if anything is found deficient to the Commanding Officer of the Garrison.'¹⁵

Formal punishments followed Courts Martial, such as the occasion in 1756 described by Corporal William Todd,

'A Deserter belonging the Marrines was Shott in the front of our Encampment, our whole line being under Arms & Each man March'd singly by him as he Lay to strike terrow in the rest etc.'¹⁶

who in the same diary entry tells us that his men had to smarten their appearance for a formal parade,

'Here I made Each man a Ball [an early form of blanco] & Colour'd his Buff [i.e., bring up his buff leather accoutrements to a smart standard] and was Allowed 4 2 ce [4 pence halfpenny] per man, against the review before His Royal Highness the Duke of Conberland & Sir John Ligoneer, where we went through the different Evolutions firings etc.'

Such accounts confirm that discipline was enacted by those with the formal legal authority vested in their rank and structural position in the unit, as now.

We may therefore conclude that, whilst there have been changes of detail, for example in the nomenclature of the rank structure and in other elements such as the forms of the badges of rank and the nature of the punishments legally available to those in authority, the selected elements chosen from the *formal command structure* model in Chapter Three are fully recognisable back to the eighteenth century.

However, if we examine the evidence from the mid seventeenth century we see a different picture, which seriously challenges the validity of the model in its application to that time. Whilst it shows that there was indeed a formal system for command, clearly represented by such elements as the apparatus of commission, military authority, discipline and punishment, and there was a formal system for structuring a unit into subunits - companies in the infantry and troops in the cavalry - some of its aspects were less well defined than in later years. This is apparent, for example, in the relationship of the Northern Horse to the Royalist Army in 1645, as described by Richard Symonds, a member of the King's Lifeguard of Horse:

‘Wednesday [4 June 1645]. The Northerne horse left his Majesties army, and notwithstanding his promise to them on the word of a King he would go into Yorkshire after Oxford was relieved; but upon persuasion returned and marched with us.’¹⁷

In this example we see that, although they were part of King Charles's army, these regiments apparently felt that they were not fully bound in to it, or to the King as Commander-in-Chief. Similarly, the King could not give them a direct order, but had to invoke a previous promise and use persuasion.

A similar example of conduct that does not fit into the formal hierarchical pattern of later years was an incident in August 1650 described by Captain John Hodgson, an officer in the Parliamentary army, in which the choice of a new colonel was put to the soldiers in what appears to have been an open and free-for-all vote:

‘Not to omit one thing when we were about Alnwick, several colonels came into the head of the regiment, and told the soldiers, the general was much troubled such a

regiment should want a colonel; who would they have? ... The colonels asked, if they would have Colonel Monk? “*Colonel Monk!*” said some of them, “What! to betray us? We took him, not long since, at Namptwick, prisoner: we’ll have none of him.” The next day the colonels came again, and propounded the case afresh; and asked if they would have Major-General Lambert to be their colonel? At which they all threw up their hats, and shouted *a Lambert! a Lambert!*¹⁸

Such a state of affairs would not have featured in any of the other time periods considered in this chapter.

It is interesting to see that this apparent step change in the *formal command structure* between the mid seventeenth and mid eighteenth centuries coincides with one of the periodic ‘military revolutions’ described by Bellamy in the *Oxford Companion to Military History*¹⁹. Drawing on the work of Roberts and others²⁰, he describes how the changes in battlefield deployment from great blocks of troops in the sixteenth and seventeenth centuries to line formation in the eighteenth necessitated a ‘vast increase in officers and NCOs’²¹ in a unit. It seems likely from the quoted material above that these changes also brought with them a sea change in the ingredients of the *formal command structure*.

Assessment

Our test of the model, therefore, has shown that the selected elements of the model of the *formal command structure* would need some adjustment to cover the events of the mid seventeenth century, although they apply reasonably well after that period. While there was certainly what might be described as a system for formal command in the seventeenth century, there was more scope for collective action on the part of soldiers and regiments to resist the wills of their commanders than there was in later periods.

We now pass on to the selected aspects of the *informal structure*.

The informal structure

*'Fill 'em up, fill 'em up; it is my birthday [repeated twice]
Don't stop, don't stop; I love to hear the corks go pop, pop, pop!'*²²

*'One night round the camp fire some soldiers were sat
Talking of sweethearts they'd had'*²³

*'This song is well sung I make you a vow,
And he is a knave that drinketh now!'*²⁴

Once the existence of a formal set of rules has been established, it is a short step to conclude that there must also be similar, informal, conventions of behaviour. The question is not, therefore, whether some form of informal structure existed in the British Army in the periods being discussed, but rather whether or not the chosen aspects of the *informal structure* in the model can be applied to advantage as they stand, without modification, to those periods. These aspects, listed above, are the existence and nature of *legitimate* and *illegitimate secondary adjustments*, described in Chapter Three on pages 117 to 121 and the five-fold suite of informal relationships which are explained on pages 92 to 109 of Chapter Three.

Legitimate secondary adjustments

This sub-section contains examples of rule-breaking or rule-bending with the permission, or in full sight of, of figures of authority. These next few examples show that the practice was a normal and natural part of unit life throughout the periods under consideration, and that the model fits the circumstances reasonably well.

We start with an incident during the Second World War, described by James Lucas when public, but unofficial, action taken against recruits under training who were deemed to be dirty:

*'Most [recruits] settled down and kept themselves clean, but there were always a few who would not wash regularly or thoroughly. They were taught a lesson by means which although unofficial and frowned upon was still carried out. They were bathed in public on the square.'*²⁵

If these measures were frowned upon and if a ban on them had been enforced, they could scarcely have been carried out 'in public on the square'. The formal chain of command must therefore have tolerated them at least.

Gary Sheffield, in his thesis on officer-man relationships in the First World War, which we will revisit later when examining informal relationships, tells us of the custom in some contexts of officers, the figures of authority, bending the rules:

'Given the hazards of trial by FGCM [Field General Court Martial], some officers were prepared to turn a blind eye to what, in military terms, were serious crimes. There are many accounts of exhausted men being found asleep on sentry duty in the trenches, but according to Pte A.M. Burrage, a middle-class soldier who was often critical of the military system, officers were usually 'too decent to make a song about it.' The trick was for the officer to wake the sentry up without acknowledging that the soldier was asleep.'²⁶

Fifty years earlier, Captain Colin Campbell told a friend in a letter how he had bent the rules in the cause of recovering from illness. He had been given three weeks sick leave after falling ill and was spending it on a ship in Balaclava harbour where he could be warm and dry. When, during his convalescence, the ship had to sail to Smyrna he decided to stay on board, contravening his orders to stay in the Crimea. He did so and returned safely in a few days. Shortly afterwards, the ship once again had to make the same journey and he made the same decision, though this time he informed his superiors. He recorded in the letter,

I am going to take another trip in the vessel to Smyrna, although totally against orders, the Brigadier and the Medical Board agreeing to shut their eyes to the fact.²⁷

In much the same vein, Lieutenant-General Richard Barter recalls an incident during the occupation of Delhi immediately after the successful siege in 1857, when he was a captain,

'In the afternoon about 4 o'clock, my orderly, Joe Fullalove came up to me with a mysterious air and told me that he had got summat as he wished to send to Kussowlie to Mrs Barter in remembrance of Delhi if my honour had no objection. I thanked him and asked what it was, to which he only replied by wagging his head in a most sapient manner as he walked away. In about ten minutes back he came with his comrade both actually staggering under a huge cheval glass [a tall mirror fitted to an upright frame²⁸]. I said, 'It's fine, Joe, and no mistake, but how could I ever manage to send such a thing as this to Mrs Barter?' Joe replied 'You leave that to me sir, only say the word and it shall be done.' So I said the word and it was packed there and then in a

Persian carpet and up it got safe enough through Spare, the Mess Sergeant, I believe.’²⁹

This activity was technically looting, and therefore forbidden³⁰. However, such was the hatred among the British forces for the Indian mutineers and their political masters that no regard was taken for their property. Barter therefore apparently felt no pangs in allowing his orderly to loot this item on his behalf and was clearly not in any fear of official disapproval.

Sergeant Stephen Morley, then a company pay sergeant in the 5th Regiment of Foot, tells how in 1812 he was advised by his commanding officer to forge a signature:

‘Once, and I shall never forget it, - I had made the returns ready for signatures, first of the quarter-master, and then of the Commanding Officer; after the most diligent search, not being able to find the former, the Colonel pounced upon me, and after my candid explanation of the dilemma, he said, “sign it yourself;” - “How, Sir,?” “as quarter-master,” I did so, and meaning my signature to be greatly *dignified*, I adopted for the first time the illegible mode I have used ever since.’³¹

This forging of a signature unquestionably broke the rules of the *formal command structure*. However, the personal involvement of the Commanding Officer made this *secondary adjustment* a legitimate one.

The practice of rule-bending for the smooth running of daily life in the eighteenth century army is mentioned by Odintz in his thesis on the British Officer Corps. He discusses the maintenance of discipline at regimental duty, and makes the point that unofficial violent action was condoned in certain circumstances by regimental officers:

‘Casual violence may well have been an effective substitute for formal legal proceedings, saving the soldier from a more severe flogging, and saving his officer from the imputation that he could not control his men without invoking formal sanctions.’³²

Furthermore, in his investigation of the life of the common soldier in the same period, Stepler has shown us that there was a widespread unofficial understanding that private soldiers might seek work from civilian employers to amplify their meagre pay. In general, officers only objected when this work kept the individual from his military duties.³³

An instance of rule-bending with the approval of authority in the seventeenth century is provided by Captain Richard Atkyns. In his memoir, he describes a time in 1643 when the

regiment of which he was a member was commanded by the local commander, Prince Maurice, to go to quarters after a long night march. However, the army's rear guard was then attacked and scattered, and the commander was taken prisoner. The problem was then that the regiment had its orders - to go to quarters - but there was a military need to do something else - counter attack. Accordingly, he asked his superiors' permission:

'My Lieutenant-Colonel, my Major, and the rest of the officers, advised what to do in this case; and the result was, that Prince Maurice having himself commanded his regiment to their quarters, they were subject to a Council of War³⁴, if they should disobey command; to which I answered (being eldest captain) that I was but a young soldier, and if they would give me leave, I would draw off my division and run the hazard of a Council of War; they told me, they might as well go themselves, as give me leave to go; but if I would adventure, they would not oppose it, but defend me the best they could.'³⁵

Illegitimate secondary adjustments

All the examples in this sub-section show activity that was intentionally carried out but had to be concealed from figures in authority, and therefore were considered by those concerned to be illegitimate.

A Second World War private soldier writes of a time when he and some of his mates were on an extended duty as fatigue men, working at Battery HQ painting offices, and thus close to the motor transport garage:

'We got on well with the drivers and garage staff as all accidents had to be logged, ending up like courts of enquiries. If no persons were involved, after the staff sergeant left for the day, the lorry was brought into the garage and the mechanics would check engine, braking system etc, panel-beaters would level out all dents and bashed wings, then we would paint the bodywork with quick-drying khaki paint and repaint the coloured artillery, battery and regimental signs. Any emergency at night, they knew where to find us.'³⁶

The illegitimate nature of this activity is made clear by the need to wait until the staff sergeant had gone off duty before it was begun.

Captain Harry Sliedmann describes how he obtained a particularly suitable horse in France in 1917,

‘I became her proud owner as a result of one of those weary homeward treks by night, after serving the guns. Dawn was just breaking and I rode, as usual, at the head of a long column of empty ammunition waggons. That night, the Veterinary sergeant was the NCO in charge of the parade and, as we were passing down a narrow lane in open country, he rode up to me with a predatory twinkle in his eyes. Had I noticed, a moment ago, that as we passed some horselines there was a horse with a loose halter, standing by the side of the road? I had not noticed, but a loose horse was worth investigating, and in a minute or two she was a docile and decorous addition to our column. On closer inspection, when she was safely tied to our picket ropes, she proved to be a jewel beyond price ...

But thievery, in our war, was not just a simple business like cattle-rustling and we were well aware of the risks to which we had exposed ourselves.’³⁷

However, they now needed to conceal her from the prying eyes of the Cavalry colonel who came looking for her:

‘Between us, the Veterinary Sergeant and I devised a scheme for the frustration of such inquisitive interference. There had been, until then, only one entrance to our horselines; we got another one cut through a hedge, diagonally opposite. An observer was posted near the original entrance to report in good time the arrival of any suspicious interlopers, and my groom was instructed, on receipt of an agreed signal, to take the Missus [the soldiers’ nickname for the horse] off the horselines and conduct her safely away through the new entrance. It soon turned out that our measures were not superfluous. Three times in the course of the following week their use was called for, and each time with perfect success. Our horselines were open to inspection at any time, we innocently boasted.’³⁸

The model’s concept of *illegitimate secondary adjustment* perfectly fits this situation where advantage is taken by soldiers in the knowledge that this action is against the rules and they then take measures to deceive and outwit the forces of authority.

Moving to the nineteenth century, Private Robert Waterfield tells how individuals disobeyed the rules governing the consumption of the rum ration, in India in 1848,

‘In consequence of several men having been confined for drunkenness they [the officers] issued an order for every man to drink his grog at the tub where it is served out, thinking by this means to put a stop to the men getting drunk. They might as well try to stop the wind, for the men, or at least a great many of them, get false bottoms fixed in their tin pots, and when they go for their grog it is measured into these. Those

who want to carry grog away will take a small portion of bread with him [*sic*], which he will be eating, so as to allow his grog sufficient time to run through a small hole which is in the false bottom. They can then raise the pot nearly upside down, without spilling the liquor; this enables them to carry it away and if they don't want to drink it, they can always get plenty of men who will purchase it at four annas per dram, just four times its first cost. By this means are the Colonel's wishes baffled!'³⁹

Once again, this deception perfectly fits the model's analytical category of *illegitimate secondary adjustment*.

Similar examples of *illegitimate secondary adjustments* can be found in memoirs of the Napoleonic period, as illustrated by Sergeant James Anton's recollection of his time guarding prisoners of war in 1804, as a private soldier in the 42nd Foot,

'The prisoners were locked up at sunset, and then the sentries, who were out of immediate view of the guard-house, laid their firelocks against the sentry-boxes and amused themselves by playing at putting-stone, pitch-and-toss, and such-like amusements, without fear of detection; for the cordial unity of feeling existed throughout the corps, so that as soon as the officer, sergeant, or corporal of the guard made his appearance, it was notified in an instant to the most remote corners, without his being aware of the communications, and our gambling amusements instantly ceased.'⁴⁰

There is no sign that *illegitimate secondary adjustments* were less prevalent in earlier periods, as these next two extracts from personal memoirs show. In the first, Sergeant Roger Lamb describes how some of his comrades had sold their 'necessaries' [military clothing and equipment] to finance their gambling and covered up the fact,

'... when the officers inspected and reviewed the state of their necessaries. On such occasions they frequently borrowed shirts, shoes, stockings, and other articles of regimental appointment from their comrades, who happened to be absent on guard, while the inspection and scrutiny took place. In this manner they frequently eluded strict examination.'⁴¹

In the second, Sergeant Nehemiah Wharton tells of a similar incident in 1642, after a warning had been given by the officers that looting would not be tolerated:

'Fryday several of our soildiers, both horse and foote, sallyed out of the City unto the Lord Dunsmor's parke, and brought from thence a great store of venison, which is as good as ever I tasted, and ever since they make it their dayly practise, so that venison is almost as common with us as beefe with you.'⁴²

Assessment

It seems, then, that the model's characterization of *legitimate* and *illegitimate secondary adjustments* serves well in all the periods considered. This raises a question as to whether or not this indicates a weakness, a plasticity, in the model: in serving all periods perhaps it is not well enough defined to be a useful tool in a particular historical context. However, the existence of such activity, and the attitudes which give birth to it, may be identified as a natural human reaction to having to live under a code of discipline, which can reasonably therefore be expected to show in evidence from any period. In that case we would need the concept of *secondary adjustments* in any model that tried to capture behaviour in such contexts. Similarly, the relevance of the distinction between *legitimate* and *illegitimate secondary adjustments* to all periods reflects an adaptability among individuals in the chain of command which might be expected in situations where there is conflict between the rules and the needs and desires of their subordinates.

Informal relationships

A more testing question than the existence of *legitimate* and *illegitimate secondary adjustments* may well be whether the model of the five informal relationships could be used in a meaningful way in all these periods. We will now examine these elements of the model in the same sequence as in Chapter Three.

Close friendship

The element in the model which I called *close friendship* appears from time to time in the historical material, though not often. This is consistent with the observation in Chapter Three that this relationship is a rare and special one. Indeed, in first hand accounts it is usually only revealed by the author's reaction to *close friend's* death, perhaps because the relationship is so closely bound into the normal pattern of life that it seems unnecessary to mention it until the thread is broken. The following quotations show examples of its occurrence in first hand accounts.

First, and happily, my correspondent Gunner Jock Hanbury reports that he is still in touch with only one fellow member of his battery, Arthur (Geordie) Williams, a man from Newcastle who served on the same gun as him. They had not met before the war, but have never lost touch since.

Secondly, but more sombrely, Lieutenant William St Leger confides in his diary about his feelings of loss following the death of his colleague, Denis Buxton, in 1917,

'I do miss old Denis so, Henry too, but Denis more. ... When I shared a tent with him I used to wake up in the morning and feel my heart glow with happiness to see him sleeping peacefully at the other side of the tent. Then I used to get up and exhort him to do the same.'⁴³

In the same vein, Lieutenant Arthur Moffatt Lang mourns the death of his great friend Elliot Brownlow in 1858, in the closing stages of the Indian Mutiny

'The death of my dear friend Elliot has of course cast a gloom over the campaign as far as it concerns me, and has rendered it distasteful to me, and spoiled all my pleasure in war and victory and Lucknow. He was a friend such as I can never find again in this world, more than a brother to me. ... In him the corps [the Bengal Engineers] has lost its finest young officer, and I have lost such a friend as I can again never find. God bless him.'⁴⁴

We can see that this close relationship was reciprocated from Elliot Brownlow's final letter to him, a letter to be opened only upon his death,

'Don't regret me as I believe that if I die I shall go direct to a happier world. That you were under the Divine Providence the means of bringing me to abandon a course of folly and sick [*sic*] for true happiness at the throne of grace has been the cause of

making me love you with an affection and respect I have never felt for any other man of my own age.’⁴⁵

Sentiments of the same quality are shown by Sergeant Timothy Gowing as he remembers his grief at the loss of a comrade at the Battle of the Alma four years earlier,

‘After the enemy had been fairly routed, I obtained leave to go down the hill; I had lost my comrade and I was determined to find him if possible. ... I found him close to the river, dead. ... I sat down beside him and thought my heart would break as I recalled some of his sayings, particularly his talk to me at midnight on the 19th;’⁴⁶

In an earlier instance, Sergeant Stephen Morley describes ‘my never to be forgotten friend Michael Wall’ in his Peninsular War memoirs⁴⁷, making a distinction between him and the other individuals with whom he interacted during his years in the Service.

These examples all have in common relationships that transcended the usual bounds of that which is called *friendship* in this thesis, a distinction well made in the final extract in this subsection. It comes from Odintz’s thesis on the eighteenth-century British Army, from the pen of a Lieutenant Armstrong,

‘The Distress I felt on the Death of my much valued friend Capt. Leslie...cast such a Damp on my Spirits that I was for some time insensible to every Object around me. A more amiable young man never existed. Now that He and Sir A. Murray are gone, I have no particular Intimates in the Regt. - Altho I am happy to say, that, with every one I am on the best footing. But these were the Companions of my Early Years, my Schoolfellows. On their friendship I could depend, But now they are no more!’⁴⁸

The discrimination of *friends* and *close friends* in the model closely matches Armstrong’s comparison of those with whom he is ‘on the best footing’ and the companions of his early years, his ‘intimates’ on whom he could depend.

Friendship

We will now explore how the concept of *friendship* maps on to first hand material from the various eras under discussion.

It should come as no surprise that this relationship is well represented in Second World War first hand literature. It is the common, sustaining, relationship of peers within

groups of subunit size and below. For instance, Lance Bombardier Spike Milligan says in the forward to his second volume of wartime memoirs, 'I had with me wonderful comrades who made life worth while'⁴⁹, a sentiment paralleled by Gunner Jock Hanbury's remark, '...with characters around in abundance, life on the wartime gunsites was never dull'⁵⁰.

In the same way, first hand material from the First World War shows that the same quality of relationship existed as common currency among soldiers, as these three extracts from personal recollections of the Western Front illustrate,

Corporal George Coppard says of his life in France in 1917 that 'The daily comradeship of my pals ...gave me strength.'⁵¹

Private David Jones describes the relationship between two saturnine men, Joe Donkin, and 'old Craddock, his most near associate - they always managed to get on the same Fatigue and used to sit silent together in the boozers'⁵²

An officer writes in a letter, 'One of the 10th Service Battalion York and Lancaster Regiment got held fast by the mud and slime in a shell-hole which flooded as he struggled. To haul him with ropes was impossible as he would have died. It took four nights' hard work by the Pioneers to get him free. His comrade stood by him day and night under fire. He fed him by means of a long stick.'⁵³

Turning to the nineteenth century material, we again see a pattern that fits the characterisation of *friendship* in the model. We begin with Captain Colin Campbell, whom we met above convalescing on board a ship at Balaclava in December 1854, contemplating the contents of a parcel he has just received from home and writing that 'The little black cap is a great treasure; the gloves are only surpassed by Archy's; the sausages will create great excitement in camp...'⁵⁴ The significant element in these remarks is that, with at least a fortnight's sick leave ahead of him, Campbell is going to keep the sausages until he returns to camp. It seems that he wants to share them with his colleagues instead of eating them where he is. Such a desire to share is a characteristic of *friendship*.

In another account from the mid nineteenth century, Lieutenant General Richard Barter gives an account of an escapade carried out by a group of young officers during the Indian Mutiny when there was a pause in the military action which coincided with a dearth of rations.

‘Bally’s long duck gun was a great Godsend. It took a lot of little squares to make a charge certainly, but the results were grand. It carried so much further, and brought down three or four [pigeons] at a discharge so that for a day or two we fed right royally, and thought that we’d hunger no more, but alas, the pigeons grew wary and avoiding our vicinity betook themselves to the neighbourhood of the Enemy. Day after day we watched them hoping for a chance, but no use, and at last an irresistible craving for roast pigeon seizing us we resolved to literally do or die. Bally Smith, Levelly (known as the white Demon), Haines (or Badmash [Indian Army word for ‘bad character’⁵⁵] as he was called) and myself started off for game. I carried an Enfield rifle and Bally the duck gun, the Demon and Badmash being armed with carbines.’⁵⁶

The use of nicknames and the informal peer group activity clearly indicates the relationship of *friendship*.

As another illustration from the mid nineteenth century, Colour Sergeant George Evernden remembers the time of his deployment to the Crimea with a number of other members of his battalion as a private soldier fresh from training. Shortly after disembarking, they erected 16-man tents and were then issued with rations. He tells us that they immediately shared out the food in pairs: ‘We shared out the biscuit and sugar into eight lots so that each 2 comrades had their own.’⁵⁷ This ordinary little detail is redolent of two particular aspects of the relationship of *friendship*, that of an expectation of sharing between *friends* and the fact that the relationship is such common currency among those who live and work together that it can be assumed to be available as a means of distributing food.

A Peninsular War example is provided by John Cooper, a senior NCO in the 7th Royal Fusiliers who recalls a skirmish in early 1812. He was then a private soldier in the light company,

‘We rejoined our company [from a reconnaissance with the Major of the battalion] just as the enemy’s skirmishers opened fire upon us. Here two of us made our *Wills*. My comrade said, “If I be killed, you take my knapsack.” I said, “If I be killed, you take mine.”’⁵⁸

and in another part of his memoirs he makes an interesting observation about another of his colleagues,

‘Now this Clapham [a private soldier in Cooper’s company] was a queer fellow; he generally had plenty to eat, but where he got his eatables was quite another thing. He did not tell every one.’⁵⁹

Sharing is one of the characteristic signs of *friendship*. In the first quotation, Cooper and his comrade enter into a sharing pact, ensuring that their possessions go to a *friend*. In the second, Clapham did not share his food and so it is reasonable to conclude that he lacked *friends*. This is consistent with the description of him as a ‘queer fellow’, which can be taken to mean that he did not fit into the informal groups around him.

As another example from the same era, Frederick Pattison recalls that towards the end of the Battle of Waterloo, at which he was a subaltern, ‘On halting, a number of little coteries were formed to discuss the proceedings of the day ...’⁶⁰ These ‘coteries’ would have consisted of groups of *friends* who naturally drifted into each other’s company when there was a pause.

The same sort of pattern is present in the eighteenth century material, as these next examples will show.

First, Richard Davenport, then a junior officer in the Life Guards, writes to his brother that,

‘Captain Taylor has a female correspondent in England, with whom he is honourably engaged. He entertains us with her letters, which are excessively foolish, as well as his answers, which he expresses without reserve.’⁶¹

Such sharing of personal material would only be acceptable between *friends*.

Second, we read in the diary of John Peebles, a junior officer in the 42nd Foot, an entry for 25 March 1779, ‘met at the Coffee house in the Eveng. my old acquaintance & chum Balnabie he is eldest Capt. & has the Light Compy. of the 74th. we spent the evening together with a party at Black Sams’⁶².

This incident has many of the characteristic elements of what is described as *friendship* in the model. The relationship is obviously warm and is appropriately exercised in the informal surroundings of a coffee house and a place where people gathered to spend the

evening. Interestingly, the text also suggests that the relationship was formed some time earlier and had lapsed: this is the first time that Peebles mentions this ‘old acquaintance & chum’ in his journal, and we can see not only that he is in a different Regiment but also that Peebles was not aware until he met him on this occasion that he was in command of the light company of that Regiment. It is likely therefore that Peebles and Balnabie were exercising the revival of old *friendship* that had suffered separation by circumstances - a characteristic of *friendship* described on pages 98 and 99 of Chapter Three.

Next, Corporal Todd’s journal of the Seven Years’ War provides us with several cases which fit readily into the relationship modelled as *friendship*, of which the following are three examples. In the first, Todd and his comrades are on board ship off the coast of France in 1758,

‘My Comrade, Samuel Shaw, got a Bed-tick [fabric], as good as New, & I have brought a Board a very good strong Sheet that I got at Cancalle, so that we have agreed to have Each of us a pair of Breeches out of Each, & Thomas Poyne & George Darker, Taylors in our Company, made them up for us here on Board of ship for one shilling per pair. And we have got Each of us two pair, so that we think ourselves well laid in for Breeches as they are of great service to us here, as the most of us was very Badly of for Breeches by tearing them so on Board etc.’⁶³

Sharing good fortune indicates *friendship*. However, note that Poyne and Darker were not prepared to work for nothing and so would not be counted as *friends* by Todd and Shaw. In a similar incident, after they had landed in France two months later,

‘... we are in great wants of Linnen to shift us with, but one of my tent-mates happen’d to light upon some shirts [and] gave me one. They were Course but they do very well at this time etc.’⁶⁴

The expression ‘tent mates’ superficially indicates nothing more than that these soldiers shared accommodation. However, the sharing of the shirts indicates a relationships of *friendship*.

After a period of two months’ leave at the end of 1758, Todd returns and catches up with what has been going on among his *friends*,

‘In Quarters at the City of Canterbury. Now begun to meet with all my Old Comrades & found that Samuel Shaw had got Married, and George Day, Wm

Gambole & Elias Perry, all belonging our Company, had been Detected by Serjeant Glenon for Sheep stealing & had been punish'd since I went upon furlow etc.'⁶⁵

From the seventeenth century material, we can observe a few references to relationships that fit the model of *friendship*, though, as we considered above, because the material is so sparse such references are small in number. Our first example is from the memoirs of John Gwynne, a Welshman who joined the Royalist army in 1642 as a private soldier and subsequently rose to be a junior officer, remaining with the exiled Charles II's army in Europe as an officer in the Royal Regiment of Guards. He remembers that on one occasion (probably in 1658⁶⁶) his regiment was in a difficult situation without orders, and the senior officer present, the major, would make no decision. He 'neither came nor sent, but let us go as we came at; which I was something concern'd, and spoake to Ensign Sackfield, and Ensign Stoner, my familiar associats...'⁶⁷. These words, 'familiar associats', chime well with the definition of *friends* in the model, and the fact that they resorted to each other when they were in difficulties indicates that they enjoyed a measure of mutual trust, which is also a feature of *friendship*.

Our second example is provided by Sergeant Nehemiah Wharton who recounts in passing in a letter in 1642 how he invited an old associate of his, Davey, to bring a friend to dine with him. 'This night I invited your man Davy and his comrade, and made them welcome.'⁶⁸ Not only are Wharton and Davy *friends*, in that they have known each other for some time and choose to eat together, but Davy brings with him another man who, in the terms of the model, is identified by Wharton as Davy's *friend*, rather than his own.

The model's category of *friendship* seems therefore fully applicable through all the periods considered.

Association

Because British society has become progressively more egalitarian over the periods discussed⁶⁹, as we go back in time it becomes less and less likely that relationships across ranks would be on an equal footing. If *friendship* across substantial rank gaps is not considered legitimate in the present day, as we saw in Chapter Three, then we may also assume that it is most unlikely to have been the norm in earlier periods either.

Working on this assumption, then, we may conclude that warm relationships across substantial rank gaps, where we find them, cannot fit the model's characterisation of *friendship*. The model provides only two viable alternatives to account for such relationships, *close friendship*, which transcends the division caused by rank, and *association*, which incorporates it. We will see in this subsection that warm cross-rank relationships did indeed exist in all the periods examined, and we will assess the suitability of the model's characterisation of *association* to encapsulate these relationships.

The Second World War material reveals that warm cross-rank relationships were a regular and important element in everyday life, as these next two extracts illustrate,

In the first, a Battery Commander, Major Chater, speaks to one of his men, in Italy in 1943,

“Have you any of that fruit cake left, Milligan?”

“No, sir.”

“Just asking, Milligan. It's a hot evening, I don't see why we shouldn't indulge in a dip, got your costume?”

“No sir, I've learned to swim without it.”

Adjacent to a POW Camp where a brass band played Tyrolean Waltzes, we enjoyed a delicious swim in the Med. starkers, save Chater who wore his knee length 'drawers cellular,' 'something to do with an officer being 'properly dressed'.'⁷⁰

This is a conversation that is clearly indicative of *association*. The Major tries to get some cake from one of his men, who feels perfectly free to deny it without apologies, while retaining the respectful term of address, 'Sir'. The question of swimming is not dealt with as an order or instruction from the senior person, but as a discussion, and the reply is a joke from the junior.

In this next example, in Burma in 1944⁷¹, an infantry sergeant is approaching a private soldier ('Jock') in his platoon to tell him that he is about to give him a difficult and dangerous task. The sergeant speaks first,

'“Aye-Aye, Jock lad, w'at fettle?”

“Not bad, sergeant, thank you.”

“Champion! They tell us yer a good cross-coountry rooner?”

“Oh ... well, I've done a bit ...”

“Girraway! Ah seen ye winnin' at Ranchi - travellin' like a bloody trail 'oond w'en the whistles gan on. 'Ere, 'ev a fag.”

“Ta very much, sarn't. M-mm, Senior Service...”⁷²

The terms of address emphasise the differences in rank between the two speakers, whilst the conversation is jovial and informal. The private feels sufficiently relaxed to comment on the type of cigarette that he has been offered.

Gary Sheffield has covered the area of cross-rank relationships comprehensively in his PhD thesis⁷³. Three extracts will show that what he investigated was a set of relationships that fits well into the category that I have defined as *association* in my model,

'Some officers certainly believed that they enjoyed close relationships with their men. A subaltern wrote of the family atmosphere in the 16th Lancers. At 'stables' an 'opportunity was provided for the most intimate relationship to be established between officer and men'. Privates discussed their affairs with their officer, while old soldiers would give 'friendly warnings' to inexperienced subalterns, without 'the least impairment' of discipline.'⁷⁴

This warm informal behaviour across ranks, conducted without compromising differences in rank, are exactly as described in the model by the term '*association*'.

'One matter, absolutely central to the whole question of officer-man relations, has yet to be addressed: how could officers demonstrate friendship for their men and yet retain their authority? Capt. Hamond [*sic*] in his unpublished treatise on officership, had some firm, common-sense views on this question. He stated that men will follow an officer who has a strong, attractive personality and who 'personally looks after their bellies and beds.' However, he continued, 'any form of familiarity that lowers your own position' should be instantly checked, 'but for God's sake don't always be thinking about your own dignity, it should be there without any possibility of mistake for everyone to see'. In sum, the officer needed to tread a narrow line between paternalistic friendship for his men, and undue familiarity.'⁷⁵

Association precisely models this relationship of closeness without the familiarity of equals.

‘Wyn Griffith, a company commander in 15/RWF, left an excellent pen-portrait of his relationship with his company sergeant major. Relaxing together over a glass of whisky and a pipe in the company officers’ mess, they would gossip about the men of the company. Griffith made two revealing remarks about this relationship. Firstly, ‘Our life thrust us close together; his [the CSM’s] position was in its way as solitary as my own’. Both had responsibility for their men. Both needed to strike a delicate balance between being part of the company ‘team’ and being slightly aloof from it. Secondly, the gossip allowed Griffith to find out incidents in the life of the company ‘unknown to the least unapproachable of company commanders, unguessed at in spite of the close contact of life in the trenches’. For example, ‘Had I heard what Delivett said when a pip-squeak blew some mud in his mess tin...?’ In short, the CSM provided an important link between the private and the company commander. In this case, and many others, the NCO and officer worked together as a harmonious team. Similar relationships could exist between other grades of NCO and officer, but in all cases, they had to be founded upon mutual goodwill and carefully nurtured.’⁷⁶

This relationship is typical of *association* between a commander and his most senior non-commissioned officer, providing mutual encouragement and a channel of communication.

The nineteenth and eighteenth century first hand material presents a contrast. Accounts of informal relationships between officers and men in these periods are very rare, and this has led several authors to infer that such relationships were themselves rare. Officers, who were by far in the majority of those who leave us diaries, letters, and memoirs, hardly seem to mention their men at all. For example, John Mills and Giles Mills note in their Foreword to the letters of their ancestor John Mills, ‘A marked difference between the letters and diaries of officers in the two World Wars and those of JM [John Mills] from the Peninsula is that no guardsman, except his soldier servant, is mentioned by name.’⁷⁷ They put this down to the organisational structure of the infantry battalion, which gave junior officers nothing specifically to do with their men on a regular basis. In a similar, but more expansive vein, Odintz tells us of the second half of the eighteenth century,

‘...one of the striking features of the correspondence of British officers at this time, is the almost total absence of rankers in their accounts of battles, and their lists of casualties. There is little evidence in their letters, or in the memoirs of officers and rankers, that shared danger tended to personalize officer-ranker relations. If the models of class behavior of the age had not already prohibited such a change in

command relations, the realities of service in the field were so different from those of modern conflicts as to remove any possibility for increased fraternization.’⁷⁸

The reason which is often given for this lack of informal contact between officers and men is that Britain had a rigid class system, and that warm informal relationships across classes were socially frowned upon. As Gilbert put it in his examination of the use of Courts Martial as courts of honour in the eighteenth century (to which we will return later as one of the case studies for further use of the model in Chapter Six) ‘familiarity with the rank and file - the common soldier’ was an honour crime. ‘Indeed, the seriousness with which this breach of behaviour was treated shows how great the gap between officers and men really was in the eighteenth-century army.’⁷⁹

It might be expected, therefore, that the relationship modelled as *association* would be missing in the data from at least the nineteenth century and earlier. Intriguingly, this is not the case, as these next examples show.

Sergeant John Hopkins writes home from Sebastopol in 1857 that he had been taken ill and had been carried to hospital ‘... more dead than alive. Every officer in the regiment came to see me ...’. When he was discharged, one officer in particular took care of him,

‘The officer, Mr Dawes, took me to his tent: he supplied me with every luxury that a well-filled purse could supply, and told me to make free with anything that was in his tent. ... what would I not face by the side of such an officer? Would I shrink from death? Perish the idea!’⁸⁰

Whilst it might be said that the officers came to visit Hopkins in hospital out of a sense of duty, Dawes clearly went well beyond the mere requirements of military duty by taking a personal and extended interest in Hopkins and offering to give up some of his possessions for his welfare.

RSM George Smith provides us with another example of warm informal relationships across ranks. In 1838 he was posted as a lance-corporal within the 11th Light Dragoons to A Troop, making the acquaintance of Troop Sergeant-Major Ennis, of whom he wrote,

‘He afterwards became adjutant and received captaincy during the Crimean campaign; he was always a great friend to me, doing me a good turn whenever he had an opportunity. I often went to see him many years after we had both left the service, and followed him to his grave in December 1882.’⁸¹

We can see here that their relationship was always asymmetrical in rank: it began when Smith was a junior NCO and Ennis was a warrant officer and it continued after Ennis was commissioned. Whilst the text appears to bear some of the signs of *close friendship*, it is probably best to identify it as *association* for the following reasons: first, Ennis is not mentioned very often in Smith's account, as might be expected for a *close friend*; second, there is no evidence that they strove to meet when they were off duty; and third we can see from this quote that Ennis did Smith several 'good turns' whilst Smith does not mention any favours in return, which indicates more of a patron/client relationship than the bonding on equal terms that is a feature of *close friendship*.

This sort of relationship was also available as a normal part of regimental soldiering in the Napoleonic period. In remembering the first time he was under fire, in 1801, General Sir Thomas Brotherton tells us that when he was an ensign he made the acquaintance of a sergeant with whom he kept up a life-long informal relationship,

'The sergeant behind me, called the covering sergeant, seeing me a raw youth then only sixteen years of age, said in a respectful but half-joking way, "How do you feel, sir?" to which I replied, "Pretty well, but this is not very pleasant!" for the men were falling fast. The sergeant, who was a seasoned veteran, liked the reply, for he seemed to take me under his special protection and care ever after. His name and appearance I shall never forget. It was Sergeant Stuckey - I often went to Chelsea to see him, where he died at the age of eighty-four, about the year 1840.'⁸²

We can see from this quotation that this relationship went beyond the superficial level that was needed for the professional conduct of the battle and became a continuing and close one.

Whilst there is no evidence in Brotherton's work that it approached the power of *close friendship*, this relationship fits the definition of *association* well.

Sergeant John Cooper tells us of his warm informal relationships with the adjutant of his battalion,

'The French being driven into France [in 1813], we counter-marched to Pampeluna [modern Pamplona] to join in blockading it. In this day's march I was taken ill of fever. After staggering on a few miles, I was obliged to fall out of the column, and sit down in a wood. The adjutant with whom I was a favourite passed by and said, I might come on leisurely.'⁸³

It is hard to see how Cooper might have become a 'favourite' of the adjutant without the sort of social mechanism provided by the relationship of *association*.

As we move back in time to the eighteenth century, we continue to find relationships that fit the characterization in the model of *association*, as we will see from the following examples. The first is provided by Odintz, as he writes about the relationship between an ensign and a sergeant in 1779, which mirrors the relationship described by Thomas Brotherton above: the ensign remembered 'that he was "much too young for so important a situation...I acted, as many older officers no doubt had done before, and since - I obeyed the directions of an experienced Sergeant."'”⁸⁴

In the second example, the then Major Richard Davenport writes to his brother in 1760 to 'tell Atkinson his friend Walford sets out with a new tilted wagon and six good horses, besides two for panniers, and with money in his pocket'⁸⁵. This might appear to be no more than insignificant gossip had it not been for the fact that Walford had been quartermaster to Captain Atkinson when Atkinson had commanded a troop of the 10th Dragoons, as reported in Frearson's editorial note to the letter. This means that Walford had been in a substantially lower social position than Atkinson and, because of the highly stratified nature of British society, they could never therefore have had an informal relationship as equals. The only way that Walford could have been a 'friend' to Atkinson was therefore by the sort of informal mechanisms encapsulated in the model of *association*.

In a third example, Odintz gives us a glimpse of the view from below, when he writes of John Dorman, 'a private in the 12th in the 1740's, [who] described in his memoirs the kind treatment he received from Captain Conyngham of the regiment who enlisted him, and "he found such a friend with Captain Conyngham, with whom he hired as a servant, that his situation was very comfortable"'”⁸⁶. This relationship would have been all the more strong because, as Odintz informs us, Conyngham enlisted Dorman. Given the master-servant context and the class difference between them, it could not have fitted the category of *friendship* or *close friendship*, but it fits well with that of *association*.

In his introduction to Captain John Peebles's diary of the American War of Independence, Gruber summarises the relationship that Peebles had with his soldiers as follows,

‘Although officers held themselves apart, socially, from the rank and file in the eighteenth-century British army, they did feel bound to the common soldiers of their companies and regiments; and they and their men developed in time a valuable camaraderie. At least, John Peebles’s diary conveys a greater sense of mutual dependence between officers and men than might seem likely in so hierarchical organization as the British army of the American War. It was not just that he and his men shared the dangers and drudgery of war - the long marches, sudden skirmishes, large and exhausting battles, protracted sieges, and periods of frustrating inactivity - or that they celebrated the same royal, national, and military anniversaries. It was also that over time he and they developed attachments to one another - genuine concern and sympathy for each other - that sustained them through the most difficult circumstances, that kept them together even when overrun in combat. ... No wonder when he addressed his company for the last time, both he and they were deeply moved.’⁸⁷

Still in the eighteenth century, Corporal Todd gives us another useful insight into his informal relationships with a senior NCO (about to be commissioned) and an officer in his memoir. In both cases, the senior individual is posted to another regiment and Todd bemoans their loss because he had a strong informal relationship with each of them,

‘Serjeant Major Barnsley of our Company receiv’d an Ensign commission from Lord Loudoun in the 60th Regiment of foot call’d the Royal Americans, he gave me all his cast Cloaths, Books etc & would very gladly have had me with him as I was very willing to agone but this our Lieut Coll Sir Wm Boothby would not admitt me to go upon no Account, so we were obliged to take our Leaves of Each Other.’⁸⁸

...

‘Capt Lieutenant Teavil Appleton receiv’d a full Captains Commission in the 65th Regiment of Foot & he would gladly ataken me with him. He Offer’d my Lieutt Colle any Man in his Company in Exchange for me, but the Lieut Colle refused leting me go by telling him he would provide for me the first Vagancy himself. These were the words Capt Appleton told me himself they had in the Canteen. So the 27th Instant Capt. Appleton gave me a Crown & took his Leave of all our Officers etc, and set of to joyn his Regiment at Norwich. This was the greatest Hardship I had ever met with by losing two of my best friends, Capt. Appleton and Ensign Barnsley.’⁸⁹

Here we see again informal relationships that were both warm and cross-rank. However, Todd gives no sign that he misses them deeply after their various departures: he never mentions Barnsley again and Appleton only appears once more in Todd’s journal, when he gets Todd to run an errand for him in exchange for a generous tip of half a crown and ‘refreshment’⁹⁰. Whilst these relationships cannot therefore be identified as *close friendship*,

the warmth recorded by Todd implies the sort of strong asymmetrical informal relationship that fits into the category of *association*.

As for the seventeenth century, the search for evidence of a commonplace warm relationship between soldiers of widely different rank yields a few instances, though the sample is tiny. The first of the two examples that we will consider is provided by Sergeant Nehemiah Wharton, who writes in a letter to his erstwhile master in 1642,

‘This morne I was exceeding sick, and the pallet of my mouth fel down; but Captain Beacon, my loving friend, upon our march sent a mile for a little pepper and put it up again.’⁹¹

Whilst it is possible that Wharton had an existing relationship of *friendship* (or even perhaps *close friendship*) with Beacon from the time before Wharton became a soldier, it is more likely that the word ‘friend’ refers to a warm cross-rank relationship because it is expressed in the context of the unit on operational service, and because this relationship does not appear anywhere else in Wharton’s letters.

In the second example, John Gwynne, then a lieutenant, describes how he and his men managed without supplies during the Netherlands campaign of 1658, ‘... whatsoever they [his men] beg’d, stoale, or made a shift for, I had my share of it, or I might have gon and do as they did, or not live;’⁹². This short passage suggests *association*, in that we can see that the soldiers gave Gwynne some of the results of their illegal scavenging, thus indicating that there was an informal bond between them.

The model of the relationship of *association* therefore fits material from all the historical periods considered, though the evidence is slight in the seventeenth century material because of the comparative lack of data.

Given the conventional view outlined above that informal relationships between officers and other ranks were not acceptable in the eighteenth century, we must ask whether or not the model has distorted the facts and whether a different model is needed for this era. If so, this may be a point of failure for the model.

Whilst the model appears to go against the received wisdom about informal officer-other rank relationships in the eighteenth century in particular, it is undeniable that the first hand evidence produced above indicates that such informal relationships did in fact exist.

Moreover, this material also shows that these relationships were both routine and warm, fitting the model of *association* even in the eighteenth century and probably in the seventeenth century as well. Indeed, this calls into serious question any received view that such relationships were frowned upon or difficult to exercise. As in the case of *secondary adjustments*, therefore, the most logical conclusion seems to be that the model has not distorted the voices of the witnesses but rather has helped us to detect persistent features in the history of the British Army that might otherwise have been concealed from view.

It seems therefore that this examination of *association*, rather than testing the model to the point of failure, has drawn our attention to factors that might not have been recognised otherwise. We will return to this element in Chapter Six.

Informal access

The next relationship in the model is *informal access*, a cooler but recognisable relationship across significant rank gaps, by which individuals divided by rank can approach each other without going through formal procedures.

The Second World War material shows that this relationship was a normal part of regimental life. Two examples will suffice. In the first, a soldier and his *friend* have arrived in Italy in 1943,

‘That night we were driven up to a small village and joined our battalion. My mate and I were posted to a platoon which had taken over a house ... Our platoon officer kept paying us a visit to see how we were. Also the platoon sergeant who was really concerned about us.’⁹³

The important aspect here, as far as informal relationships are concerned, is that the platoon commander and the platoon sergeant approach the newly arrived soldiers regularly and express their concern. Furthermore, nobody appears to think that it is an exceptional thing to do. This can best be accounted for by recognising that the relationship of *informal access* was assumed from the outset by the hierarchy of the infantry platoon, and that the assumption of such a relationship was natural and unremarkable.

Our second illustration is provided by another incident in Italy, in 1944. Rifleman Bowlby tells us that one of the officers in his company was recommended for the MC [Military Cross] but the soldiers knew that he had not pulled his weight in the action in which he was supposed to have earned it. To sort this out, one of the corporals, Bailey, approaches the company commander, Captain Kendall. Bailey subsequently tells Bowlby and his mate O'Connor,

“‘When I got in there ... Captain Kendall said, ‘Hullo, Corporal, what’s on your mind?’ ‘Well, sir,’ I said, ‘before you took over something pretty bad happened.’ I wasn’t sure how to go on but old Kendall smiled and said, ‘I’m listening.’ So I said, ‘When we were up at the hill at Perugia Mr Driver just sat in his trench. He didn’t do a thing, not even when chaps were wounded.’ ‘I see,’ said Captain Kendall. ‘I’m very glad you told me.’”⁹⁴

This incident is a clear example of *informal access*. We can see that Bailey and Kendall were not in a close relationship because Kendall does not use Bailey’s name, or any nickname, and because Bailey was not sure what Kendall’s reaction would be to his tale. We may rule out *association* between them on this evidence. However, Bailey felt perfectly able to approach Kendall and Kendall welcomed him and listened, which implies that there was at least a certain amount of trust and familiarity between them.

Sheffield provides us with a good summary of the existence of *informal access* from the First World War, writing of a particular young officer,

‘Taylor’s sense of responsibility was mingled with sympathy for the men’s condition. He tried to establish an informal relationship, mingling and conversing with them, lending a sympathetic ear to their troubles. One of Taylor’s contemporaries believed when the men ‘come to you with their private worries’, this was a sign that the officer had won their confidence.’⁹⁵

Both the mingling and conversing with the men on the part of the officer and the coming to their officer with their troubles on the part of the men are characteristic of the relationship of *informal access*.

Two examples from the mid nineteenth century show that this relationship was available then. In the first, a bandsman who has lost a hand in the Indian Mutiny and is

recovering in hospital takes the initiative and approaches the Adjutant of his battalion, who is visiting the hospital informally,

‘[he] came to me to put in a good word for him with the Colonel, so that he might stay with the Regiment, in which he had been born I believe, and not pensioned. I told him that it was no use, the Colonel had no power in the matter. “You know,” I said, “that having lost an arm you are no longer fit for the Service, what use could you be?” “Oh,” he said, “I could play the trombone, sir, I could fix a hook to my stump and play it first rate.”’⁹⁶

In this incident it is noteworthy that the bandsman initiates the conversation by speaking directly to the Adjutant. There must have been some form of mutual recognition between them, and some form of informal relationship, for this to have been possible without the bandsman making his approach a formal one. This situation therefore fits the definition of *informal access* well.

In the second, the harassed Sergeant Gowing in the Crimean War has been refused stores for his men on the grounds that the paperwork is not complete, after a hard nine mile march from their camp to the stores depot at Balaclava,

‘I at once handed my men over to another sergeant of ours (that was stationed at Balaclava to look after the interests of the regiment) and, with a little coaxing, managed to borrow a good strong mule. Away I went back to camp, as fast as the poor brute could move, straight to the Colonel’s tent. The first salute I got from one that had the feelings of humanity and who had frequently proved himself as brave as a lion (Colonel L.W. Yea), was, “What’s up, Gowing?”’⁹⁷.

Gowing did not go through the chain of command to see his Colonel, but went straight to him. However, the Colonel behaved as if this was an acceptable thing to do, thus affirming the informal approach and implying that the relationship between them was as described in the model’s characterisation of *informal access*.

Our Napoleonic Wars examples both come from the memoirs of infantry sergeants. In our first, an incident during the pursuit of the French from Oporto in 1809, an officer calls upon Sergeant Cooper,

‘In the evening we continued our march long after dark, stumbling among rocks and stones; the rain still falling, and the men silent and knocked up. ... Captain Percy, who commanded our company, being mounted and ahead, passed the word for me to join

him. With difficulty I got to his side. "Have you any bread?" said he. "Yes, sir," I replied, and gave him a loaf. When he had done eating he said, "Should you ever be in want of my help, let me know."⁹⁸

In asking a favour from Sergeant Cooper, Captain Percy was using the *informal structure*. In the absence of any evidence of *association* between them the relationship that best describes the circumstances and events in this incident is *informal access*.

In our second example, Sergeant Morley remembers a soldier exercising what is clearly *informal access* with an officer in 1808, albeit with a purpose,

'At Charles' Fort, about two miles from Kinsale, lay Captain Brodie's company, still commanded by Lieutenant Simcox. We had a bugle-man named Patrick Ganley, who was considered a splice of a wit. One morning being employed about the mess room, he accidentally heard something about Lieutenant Simcox! Pat quickly hastened to the road by which the Lieutenant had to pass, when making the military salute, he said, "good luck to your honor [sic] captain," "and may you soon wear *two epaulettes* [which would signify further promotion to major]." "Thank you Ganley," replied the Captain, whose promotion had not appeared in orders, "and here's something for you to drink." This was just what Pat had been contriving for.'⁹⁹

As we have established above, material on social relationships in the eighteenth century is sparse, but there is enough to show that *informal access* as it appears in the model was practised, as the following cases show.

In the first, Peebles, then a lieutenant, approaches his commanding officer (who is also his brigade commander),

'Tuesday 9th. June [1778], cool last night today pleasantly warm - call'd on Col Stirling but he was not at home, he came up afterwards to our house & taking me out he asked me if I had any objections to go to the Light Infantry¹⁰⁰. I said none but hoped he wod send me to the Grs. [the grenadier company] where there was an opening, but he wod not promise'¹⁰¹

We can see here that Peebles takes the initiative by calling upon his commanding officer without prior formal appointment, and that the commanding officer reciprocates by dropping in at Peebles's billet. Both these visits fit well with the model's concept of *informal access*.

Corporal Todd provides us with our second example, from 1758, when he describes how he approached his commanding officer (who was also his company commander) hoping to secure one of the few places for leave,

‘After Roll calling I went to my Lieutt Collonel, Sir William Boothbys Quarters, & ask’d him if his Honour would be pleas’d to grant me a furlow, as he promised me at Reading in Berkshire in the Spring that I should have one. ... Numbers of our Men wants furlows & only two of a company is Allow’d to be absent from Muster by the Governments Orders, & none must go of untill there New Cloaths is Alter’d for them to go in’.¹⁰²

This incident shows that Todd, like Peebles in the first example, takes the initiative in going to see his superior officer without formally going through the chain of command between them. By doing this, he gets ahead of his rivals for the rare chance to go on leave. However, the existence of the intervening chain of command is clearly brought out later when Todd has to go through the procedure for obtaining a leave pass, which involves him in seeing both the Pay Sergeant of his company and the RSM¹⁰³. Although he bypasses this chain of command in making his request he does not get into any sort of trouble for doing so, thus indicating that his behaviour was acceptable, at least to the officer concerned. This can best be explained through the mechanisms involved in *informal access*.

The evidence from the seventeenth century for the existence of *informal access* as part of the accepted pattern of relationships is slight, but an incident reported by Captain Richard Atkyns from 1643 indicates that something resembling it may have existed.

Atkyns has raised a troop of horse which has been attached to Lord Chandos’s Regiment. This troop consists of about 80 troopers, twenty of them ‘gentlemen’. Things do not go well because ‘Lord Chandos ... afterwards used my troop with that hardship, that the gentlemen unanimously desired me to go into another regiment;’¹⁰⁴. It is not possible to infer the means by which the gentlemen made their views known to their captain, but it is clear that they took the initiative in approaching him. Although they could have used the *formal command structure* to have done so, given the comparatively loose nature of that structure at the time (as we saw earlier in this section) it seems more likely that they approached him informally. If they did indeed do so, then it is most simply explained by the existence of a relationship between them and their commander of *informal access*.

This case is complicated by the fact that those who approached Atkyns are called ‘gentlemen’ and were therefore probably of similar social status to him. The informal approach that they made to him may have been facilitated as much by wider social conditions as by structural mechanisms for communication across ranks.

We may conclude therefore that the model of *informal access* fits the cases of informal social interaction between officers and soldiers at least as far back as the eighteenth century and may have been available in the seventeenth century.

Nodding acquaintance

Given the unchallenging nature of the relationship of *nodding acquaintance* it seems the most likely of all to have been in existence throughout the periods under consideration. However, the historical material examined did not yield a single example of what could be described unambiguously as *nodding acquaintance*.

I do not believe that this absence in the literature is necessarily indicative of its absence in the soldiers' experience because the essence of the relationship is that it is a distant and casual one. It could well be argued that there would simply be little reason for any particular author to write about it.

Therefore, we may conclude that the case for or against the existence of *nodding acquaintance* in the historical British Army is not proven and that its apparent absence is not significant in the process of testing the model.

Assessment.

We have seen, therefore, that the selected aspects of the model (*legitimate* and *illegitimate secondary adjustments* and the five-fold suite of informal relationships) provide a suitable means to describe British soldiers' behaviour and social interaction in the regimental context, at least as far back as the eighteenth century. Even in the seventeenth century the historical material does not challenge the adequacy of the model, though its slight nature should not lead us to conclude that the model of the *informal structure* may be imported unquestioningly into that era.

It would seem, therefore, that either we have detected a weakness in the model, in that it seems to fit material from all eras, or the model has highlighted a remarkable

consistency in the behaviour of British soldiers at regimental duty over the past 300 years.

We will return to this dilemma later.

The loyalty/identity structure

*'Merry merry men are we,
There's none so fair as can compare with the Royal Artilleree'*¹⁰⁵

*'In the Army we're the best, from the north, south, east and west,
The best of boys are following the drum'*¹⁰⁶

We established in Chapter Three that the model of the *loyalty/identity structure* consists in a set of ideas, assumptions and expectations centred on a concept which may be called 'belonging', with the implication that a soldier tends to see himself as belonging to 'the best' group. This concept of belonging is multi-level and highly flexible because each soldier has several possible organisational levels to which he belongs, as defined by the *formal command structure*. At the start of this chapter we set out as an appropriate test of the model the exploration through the selected historical periods of this concept of belonging, its application to several organisational levels simultaneously, and the attitudes and feelings displayed by the individuals towards those organisational levels.

The loyalty/identity structure in the selected periods

Because this social structure is defined by unit organisation, the conditions for its existence can be expected to be found in any time period where there is a unit organisation that may define it. As units have had a defined structure throughout the historical periods under consideration we should not be surprised to find elements consistent with the *loyalty/identity structure* in all of them. This is indeed the case, as the following examples show.

The first is from Gerald Kingsland's memoir of the Korean War, in which he served in the rank of Gunner,

'As Einstein might easily have said, all feelings are relative. A Troop will compete with a Troop but the two will combine as a Battery to compete with another Battery,

and Batteries will combine as a Regiment to compete with another Regiment, and so on right up to Brigade and Country of Origin level.’¹⁰⁷

The existence of unit loyalty and identity is similarly well encapsulated by David Fraser in his book on the British Soldier in the Second World War,

‘If an armoured soldier - a tank or armoured-car crewman - a man joined the Royal Armoured Corps: this was, so to speak, his nation. But within the nation were many tribes, called regiments - the regiment, in this case, being the fighting unit. Each regiment had its own name, place in the Army List, capbadge, customs, likes and loathings. A man absorbed these, and the regiment was his family, a source of support in a world often alien and alarming.’¹⁰⁸

and the levels below the unit have also been identified by Lucas in his compilation of memories given by soldiers and officers of the Second World War,

‘The most important lesson in the Army’s education of its soldiers was that of unit loyalty. Almost from his first day of service the recruit was told that he was serving in the finest regiment in the Army. In time that direction was even more sharply defined in an endeavour to convince him that he was in the finest company/squadron/ battery of that regiment.’¹⁰⁹

Gunner Jock Hanbury’s letters give good examples of the flexibility of the *loyalty/identity structure* in the way that, in the natural stream of his reminiscences, he sometimes he refers to the excellence of his part of the Royal Artillery, sometimes to his unit, his battery, his troop, and his gun detachment, the level entirely depending on the appropriate level for the story he is telling. For example,

‘Mobile Lt. Ack/Ack [light anti-aircraft] was more of a family affair, a close-knit community.’¹¹⁰ (Generic level)

‘Our 404 Lt Ack/Ack Battery was formed in the Fife mining area and the lads, like the Welsh miners, loved a good sing-song, which for the BSM [Battery Sergeant Major] meant his men were of good heart’¹¹¹ (Battery level)

‘we hit an immediate problem when receiving a new Bofor [*sic*] which could only fire one round, and was laughingly referred to by the other gunteams, as “one round Betsy”’. ... [and after the fault had been finally identified and put right by the gun-fitter, Scottie] Suddenly we were cheering, laughing and yelling with delight, and even hugging Scottie in his greasy denims - V.E. Day wasn’t a patch on this - we were back in business and Betsy was exonerated.’¹¹² (Gun level)

Another example is provided by Lucas, who quotes an infantry private's account of operations in the Western Desert in 1942. It is noteworthy because it shows the flexibility modelled in the *loyalty/identity structure* in that several different levels of grouping are mentioned close together in the first person plural ('we', 'our', 'us') with no apparent need to explain how he can identify with all of them. In the following extract, I have inserted in square brackets the identification of the group referred to in the first person plural, to make this flexibility plain,

'We [his battalion] were relieved in those positions by a unit from the 1st Division and then we [his battalion] moved to a place between Medjez el Bab and Peter's Corner. The positions we [his battalion?] were now holding were called "The Basin" because the area was a number of low hills surrounding a low-lying piece of ground. At 'O' Group our [his platoon] Platoon Commander told us [his platoon] that Jerry [the Germans] was just over two miles away to the east ... our [his section] Section Corporal told us [his section] that the Hermann Goerings were expected to attack us [the troops in the area]...' ¹¹³

Lucas also cites an interesting case where regimental identity of an individual was dysfunctional. One of his informants, an officer who had to change from one regiment to another, remembered,

'When I returned to the United Kingdom in 1940, from Malta, I went to OCTU [Officer Cadet Training Unit] and was commissioned in the Royal Warwickshire Regiment. I had, of course, applied for the Royal West Kents or the Indian Army, but apparently both were full up, so I had to be content with the Warwicks. At some point during 1943 or 1944, I was transferred to the Shropshire Light Infantry, very much against my will. Most of my platoon were transferred with me and we all refused to "dog trot" [march at light infantry pace] ¹¹⁴ on parade. We kept to our regulation pace of 120 to the minute - or whatever it was. Furthermore, I refused to wear an SLI capbadge, keeping my Warwickshire capbadge up, despite my CO telling me to change it. One day Montgomery appeared on the scene and congratulated me on wearing the Warwick's badge - his old regiment - and my CO avoided me thereafter.' ¹¹⁵

It seems that this officer had embraced the *loyalty/identity structure* of the Royal Warwickshire Regiment in spite of originally wanting to join a different Regiment, but he had failed to make the transition to the Shropshire Light Infantry (SLI) when they were formally transferred, and neither had the members of his platoon. Instead, they maintained their

identity as a distinct group in, but not of, the SLI, thus creating a potential fault line in the cohesion of the unit. They only managed to persist in this separate identity by exploiting the regimental identity of the Commander-in-Chief.

The existence of a *loyalty/identity structure* in the First World War British Army is also amply indicated by its members, who reflect both their commitment to, and identification with, the organisational segments to which they belonged, and the multi-layered nature of their allegiance. Second Lieutenant Stephen Hewett was rehearsing views held by many a young officer when he said in a letter to a friend in 1916, 'I am very keen on my Battalion, and especially on my company and platoon'¹¹⁶.

Other examples are provided by R.A. Chell, an officer of 10/Essex, writing of long training marches in England, saying, 'one saw platoon pride and comradeship happily demonstrated: Platoon pride said "no one must be allowed to fall out"¹¹⁷, and Captain Sliepmann in his rather sheepish comments on the virtue of his soldiers' powers to 'acquire' other people's military stores, '... certainly it was a science capable of amazing development and, I believe, in our brigade [unit]¹¹⁸ we exploited it to its uttermost limits.'¹¹⁹

Private Ernest Atkins provides us with a view from the bottom which reflects these officers' views in all important respects and clearly fits the pattern modelled in the *loyalty/identity structure*. Extracts from his journal¹²⁰ appear in a compilation of first hand accounts of the First World War made by Moynihan, who begins by quoting Atkins' wartime identity, 'meticulously inscribed on the inside cover [of the journal]: 'Ernest A. Atkins, 26699. B. Company. 16th Kings Royal Rifles Corps. 33rd Division. 100th Brigade. 4th Army Corps.'¹²¹ and he repeats with obvious pride a sergeant-major's assessment of his platoon as, "'.. the scruffiest, don't-care lot of scroungers in the British Army. Worst on parade - but in the line the pick of the regiment.'"^{122 123}

Evidence for Regimental pride and for the Regiment as a *hot spot* for loyalty and identity is plentiful in the mid nineteenth century material, as illustrated by an observation by Evelyn, a self-appointed regimental officer and diarist of the Crimean War, in his description of an incident in the Battle of the Alma:

'The Guards advanced in line - Grenadiers on right, Fusiliers [Scots Fusilier Guards] centre, Coldstreams left. ... At this time the broken regiments of the Light Division

[who were being forced to retreat from their attack] rushed through the ranks of the Fusiliers, pursued by the Russians, who bayoneted many of them. This battalion, which had suffered great loss, having been opposed to the most direct fire of the enemy's battery, and being then utterly broken by the retreating regiment, turned and retired some paces. The fate of the battle at that moment hung on a thread. The Grenadiers and the Coldstreams on the right and left called out "Shame, shame" and the brave Fusiliers proudly recovered from their momentary panic and resumed their front.' ¹²⁴

The main feature in this *vignette* is that the disapproval of members of other Regiments provokes the Scots Fusilier Guards at the level of their *loyalty/identity hot spot* and they react against the insult by renewing the attack.

Sergeant Gowing provides another instance at this level by his insistence that his Regiment, the Royal Fusiliers, were the first ashore on the Crimean peninsula,

'It was a toss-up between us and a boat-load of the 2nd Battalion Rifle Brigade as to who should have the honour of landing first on the enemy's shore; but, with all due respect, I say the Fusiliers had it.'¹²⁵

In spite of Gowing's 'all due respect' we may infer that his judgement was probably influenced by his desire that his Regiment get the credit.

Lieutenant-General Richard Barter makes much of the quality of his Regiment (75th Foot) in his memoir of the Indian Mutiny, encapsulated in this anecdote,

'Of the 75th, months after, General Outram, the Bayard of India, said when a Staff officer wished him to send another Regiment in their place to cover the front at an attack on the Alambagh, on the ground that they had not rifles like the other Regiments¹²⁶ and were very few; "Never mind," said Outram, "let the 75th bide, they're few, but they're very good!!"¹²⁷

The flexibility of the groupings with which a soldier could identify, as modelled in the *loyalty/identity structure*, is also present in the mid nineteenth century material, as this extract from a letter written by Lieutenant Strange Jocelyn of the Scots Fusilier Guards, shortly after the Battle of the Alma in 1854, shows. As in the case of the soldier in the Western Desert above, Jocelyn refers to several different groups in the first person plural in a single paragraph, indicating that he felt equal membership of them, and I have identified these groups in square brackets,

‘10 of my brother officers were down, and I lost one third of my Company [his company]. One of our colours [his battalion] had 24 Bullets through it, and the Staff of it shot away, which will give you a pretty good idea of what it was like. The Guards [his brigade] had the post of honor...’¹²⁸

The Napoleonic period provides similar examples which could be mapped onto the *loyalty/identity structure*. For instance, Harry Ross-Lewin, a junior officer in the 32nd Foot, produces a remark in his memoirs relating to the year 1809 that echoes the statement of Barter quoted above,

‘Sir Eyre Coote expressed his high approbation of the conduct of this corps [the 32nd Foot, Ross-Lewin’s regiment], and said that when the 32nd was at the advanced posts he could sleep sound.’¹²⁹

Sergeant James Anton remembers a drunken brawl between groups of soldiers over regimental honour in 1819,

‘The -- regiment was quartered in Richmond Barracks, and after we had been a few weeks in the city, we were quartered there also. ... One canteen received promiscuously the men of both corps, to regale themselves under its roof, one room witnessed their noisy mirth, and one table frequently floated with the overflow of their pots and glasses. ... It was on one of those nights of noisy mirth, that a turbulent drunken drum-boy of the 42d [sic], on leaving the canteen received a merited knock-down from one of the same rank in the other regiment. ... the canteen (it being shutting-up time) poured out its reeling crew to witness the scuffle, while some swaggerer of the -- regiment cried out, “Down with the 42d.” This was retorted by “Well done 42d,” and “Down with the --,” “Fair play,” etc. ... Presently more than a hundred hands were raised with hostile intention, when the timely interposition and decisive command of several sergeants, of both regiments, succeeded in drawing off the men to their respective barracks, where the rolls were called, and quietness and good order restored.’¹³⁰

It is clear from this incident that the ‘swaggerer’ set the course of the fight by making it a regimental matter in crying “Down with the 42d”. It is entirely consistent with the model’s characterization of the *loyalty hot spot* that the soldiers should then align themselves along regimental lines and attack each other.

This is not to say that battalion level was the only case that counted in the minds of the soldiers of the time. Although the majority of remarks that could be ascribed to a

loyalty/identity structure seem to be at that level, a useful corrective is provided by George Hennell, a gentleman volunteer who had very recently joined the 94th Foot aspiring to gain a commission. He has given us an account of the assault on Badajoz in 1812 written shortly afterwards, and this account gives us a glimpse of the *loyalty/identity structure* of his battalion, which he must have embraced in a remarkably short time. He tells us that in the advance to the city he 'got a soldier's jacket, a firelock & 60 round of cartridges and was right hand man of the second company of the 94th Regiment'¹³¹ ... and that once he and his companions were in the defensive ditch of the citadel,

'The men were not so eager to go up the ladders as I expected they would be. They were as thick as possible in the ditch and, the officers desiring them to go up, I stopped about two minutes likewise. The men were asking "Where is the 74th?" "Where is the 94th?" I perceived they were looking for their own regiments rather than the ladders. I went up the ladder and when about half way up I called out "Here is the 94th!" & was glad to see the men begin to mount. In a short time they were all up and formed on a road just over the wall.'¹³²

These passages show us that Hennell first identifies himself with the *loyalty/identity* group of the second company of his battalion, but later the focus shifts to the battalion level as the men try to sort themselves out from their colleagues in other battalions. The soldiers' reluctance to assault seem to have been caused at least partially by their wish to be in their *loyalty/identity* groups (battalion level) and they pushed on once they heard a voice telling them where their battalion was.

In the eighteenth century material there is ample evidence for a special focus of identity and loyalty at Regimental level. As Howard has observed, '[the British were] unable even to produce an army which was more than a congeries of stubbornly independent regiments for whom tradition often ranked higher than efficiency....'¹³³, and Odintz believes that the concentration of attention at this level was a defining feature of the British Army in the eighteenth century,

'The sense of regimental loyalty and identification that permeated the attitudes and goals of the officers and men of the 12th on the Gibraltar parade ground, as well as those of the 13th in Scotland, the 35th in the South of England and the 8th in far-off Canada, is perhaps the most significant feature of British military life in this period.'¹³⁴

while acknowledging that this concentration brought its own problems,

‘To a considerable extent, particularly in the eighteenth century, the strengths of the British army, confidence and cohesion within primary groups¹³⁵, were those of the regiment, while its faults were also those of the regiment: an excessively parochial administration and a narrow-minded, idiosyncratic approach to tactical doctrines.’¹³⁶

This is not to say that the company did not feature as a locus of identity and a focus for loyalty. When James Wolfe wrote to give his advice to an ensign who was joining his first regiment, he implies that the company would be the primary milieu for the young man, ‘When you are posted to your company, take care that the serjeants or corporals constantly bring you the orders; treat them with kindness, but keep them at a distance, so will you be beloved and respected by them.’¹³⁷

Corporal Todd also shows that the company level was important to him. On 30 November 1761, he severely strained his ankle whilst on the march in bitterly cold weather, and dropped out. For the next nine days he limped on in the wake of the British army, initially falling further and further behind but eventually catching up¹³⁸. When he describes his eventual reunion with his Regiment, he does not consider that he has fully caught up until he has found his company (the day after he first made a connection with other companies of his Regiment)¹³⁹.

In the seventeenth century material, there is evidence of rivalry and mistrust between elements within both Parliamentary and Royalist armies. This is consistent with the *loyalty/identity structure*, in that the members of each element believes themselves to be in opposition to the others, and superior to them, as the following instances show.

In our first, Wharton, describing a complicated incident in 1642¹⁴⁰, calls the members of another Parliamentary foot regiment ‘*base* blew coats’ [my emphasis]¹⁴¹, and tells us of a fight between his soldiers and a troop of horse due to a mutual assumption that the others were up to no good. In fact, they were all on very similar missions against Royalist sympathisers in the area and, logically, should have cooperated rather than opposing each other. It seems that none of the protagonists saw the others as part of the same team, but rather as quarry for pillaging, in the absence of a credible external enemy to unite them.

In the second, Captain Richard Atkyns describes friction between the horse (of which he was one) and the Cornish foot in 1643, ‘these were the very best foot I ever saw, for

marching and fighting; but so mutinous withal, that nothing but an alarm could keep them from falling foul upon their officers'.¹⁴² This is in contrast to Sir Ralph Hopton's opinion, given at the same time and about the same set of incidents,

'There began the disorder of the horse visibly to breake in upon all the prosperity of the publique proceedings. ... And the Generalls being verie fully advertized of the oportunity to begin a discipline in the Army, and being of themselves verie desirous of it, were yet never able to repress the extravagant disorder of the horse to the ruin and discomposure of all.'¹⁴³

Both Atkyns and Hopton are describing the same events at the same time, but each casts the other's people (horse and foot respectively) as the disorderly parties. The model's *loyalty/identity structure* provides a simple and contextually relevant explanation for this anomaly: using the model we can say that each is likely to support his organisational segment that is of equal status to the one which represents the opposition, and that it is perfectly reasonable for each to believe that the other group is in the wrong.

The multi-level nature of the *loyalty/identity structure* is interestingly reflected in a seventeenth century example in the notes by the horse soldier and antiquarian Richard Symonds when he was describing the organisation of the horse elements in Royalist army in 1645. He identifies his position in the army as the centre of a widening series of command levels, consistent with the logic of the *loyalty/identity structure*. In his 'Suma Totalis of the whole army of horse' in 1645, he lists first his own unit (the King's Lifeguard of horse) by its constituent troops (the King's Troop and the Queen's Troop), then the regiments with which it is brigaded, and then the other brigades of horse in the army, giving the totals for each element that he describes. These totals read, 130 (the members of the King's Lifeguard), 400, 100, 200 (the other units in his home brigade), and 850, 880, 1,500, 1,200 (the other brigades)¹⁴⁴, thus indicating the widening nature of the spans of command to which he is alluding, and tracking his own position in the *loyalty/identity structure*. If he were listing the Royalist army factually and thus without any social structural content, he would have listed a series of equally sized segments (units or brigades).

The flexibility of identification within this multi-level construction also comes out of other first hand seventeenth century texts, such as that of Wharton who refers with equal ease

at various places in the same letters to his company, his regiment, and the whole force of which they were a part.¹⁴⁵

Discussion

Although it seems from the above that the concept of the *loyalty/identity structure* can be integrated with first hand material from all the periods under discussion, the degree of significance of this match, and its depth, should be examined carefully.

There can be little doubt that the first hand accounts of soldiers from the twentieth century can usefully be examined in the light of the model. There are, however, several difficulties associated with earlier periods.

In the mid nineteenth century material, there are much fewer references than in later periods to levels below the battalion or regiment. This may indicate either that these levels were less significant in the lives of those authors than of those of later eras, which would imply that the model is not valid for the period, or simply that they were irrelevant to the story that the individuals were telling, which would not challenge the model's validity.

The first possibility is supported by the fact that unit organisation, at least in the infantry, was much less complex in the mid nineteenth century and earlier than it later became. There were few, if any, enduring organisational segments below company level upon which the conventions of the *loyalty/identity structure* could focus. Platoons were a temporary organisation for battle only, and there was no equivalent of the modern section.

However, it is also possible that the authors felt it more appropriate to identify with the battalion or regimental level of the *loyalty/identity structure* when they were writing. According to the model, a *loyalty/identity segment* only becomes an appropriate focus for attention when it is compared or opposed to a similar segment. By this argument, identification with levels below the unit are not appropriate to people who are telling their story to a general audience, as in the case of memoirs, or to a particular audience outside the military unit, as in the case of letters, because such audiences are organisationally external to the unit. In all these cases, the concept of the *residual focus of loyalty* provides a good predictive model of the level that the authors will use.

The synthesis between these views, which is espoused here, is that the concept of *a loyalty/identity structure* with *a residual focus of loyalty* is a useful tool with which to examine the social workings of a unit in the British Army. However, the nature of *the* appropriate *loyalty/identity structure* (and in particular its shape) is heavily influenced by the organisational structure of the unit in question, which is different in different historical periods. Specifically, the present highly stratified *loyalty/identity structure* that runs from very small groups equivalent to infantry sections up to the unit and beyond is not appropriate to the times examined in this thesis before the First World War.

In the eighteenth century, there was a further organisational feature that does not fit with the model of the *loyalty/identity structure* of the twentieth century British Army. This was the practice of creating enduring specialist composite battalions by brigading the grenadier and light companies (the ‘flank companies’) of infantry regiments. The grenadier battalions were used as assault troops and the light companies for skirmishing¹⁴⁶. Using the model, these battalions could be viewed as *ad hoc* functional groups, perhaps analogous to the modern battle group that is formed from elements of several units under an infantry or armoured corps headquarters, and therefore more of the nature of the *functional structure* than the *loyalty/identity structure*. However, this would be to distort the real case because once they had been formed their structure could endure far beyond that of the modern battle group and they could develop their own unit identity that cannot be assigned purely to the *functional structure*.

A useful illustration is provided by John Peebles’ experience as a lieutenant, captain lieutenant and finally captain in the 42nd Foot in America between 1776 and 1782. Lieutenant Peebles was in the grenadier company of the 42nd when the Regiment arrived in America and was therefore deployed to one of the battalions of grenadiers (the fourth) with his company, being appointed adjutant of that battalion. Later in the same year (1776) this battalion was broken up and he was transferred with his company to the third battalion of grenadiers. He and his company were then transferred to the second battalion of grenadiers in February 1777. In November of that year he was promoted to captain lieutenant and returned to the main body of the 42nd, but in the following summer he was promoted again

and went back to the grenadiers as the company commander. He spent the rest of his active service in this role until he went on half pay in 1782.¹⁴⁷

There is a discernable thread of loyalty and identity running through Peebles's diary, but this is divided between his home Regiment, the 42nd Foot, and whichever was his home battalion of grenadiers at the time, as these following examples show.

We begin with a diary entry from 1776, 'Sunday 29th. The Battalion went to Church inform our compy. dress'd in britches for the first time, what would Ld. E: say if he saw us,'¹⁴⁸. In this passage, the 'Battalion' is the fourth battalion of grenadiers, of which Peebles is the Adjutant. He identifies with both the battalion and 'our compy' (the 42nd Grenadier Company), whilst in commenting on the change from the wearing of the kilt to britches he identifies himself with the customs of the 42nd Regiment.

Moving on to the following year we see that 'Cadet Potts came down from Brunswick to day on his way to N:York says all well there & likewise with the Regt. our people had another skirmish with the Rebels lately, & killed a parcel of them'¹⁴⁹. Here, 'our people' refers to the 42nd, yet Peebles is a member of the fourth battalion of grenadiers, deployed in a different area to the 42nd.

In our third example from Peebles, from July 1779, he identifies himself with his grenadier battalion when he regrets the damage done to their reputation by making the laconic entry, 'maurading & desertion, for shame Grenrs'¹⁵⁰.

It is clear from these and other entries in his diary that the two-fold loyalty and identity that Peebles expresses, both to his grenadier battalion and to his Regiment, is deeply felt. Both the 42nd Foot and the various battalions of grenadiers to which he belonged were stable organisational elements, and he is loyal to both, identifies with both, and shows little sign of feeling that one was a more legitimate focus for identity or loyalty than the other. Comparing this situation to that captured in the model, we see that there is no mechanism in the model's depiction of the *loyalty/identity structure* of the present day to allow for such a two-fold strand of loyalty and identity, because the model is structured by a single series of nesting groups. We cannot therefore say that the *loyalty/identity structure* of the model properly covers the situation in which Peebles, and many others in infantry flank companies, found themselves.

We may conclude, then, that the *loyalty/identity structure* as set out in Chapter Three could not be used unamended to enlighten our understanding of the mid eighteenth century first hand material. It seems that although there is evidence to support the modelling of a kind of *loyalty/identity structure* for the period, and although there is a clear logical link between the types of attitudes and expectations portrayed in the model and those expressed by eighteenth century soldiers, the shape of the *loyalty/identity structure* for the mid eighteenth century infantry units would have to be different to that of the twentieth.

Although it is sketchy, the seventeenth century material from the Royalist army also indicates that there may have been significant differences in the *loyalty/identity structure* compared to what the model sets out for the present day. In particular, there are indications that the basic organisational module may often have been the sub unit rather than the unit. Whilst individuals mentioned their regiments as an important and relevant element, reorganisation of sub units between regiments seems to pass without particular comment. Hodgson tells us baldly, for example, that in 1645 'Our company was appointed for Colonel Bright, to make up his regiment' adding that Bright 'had some companies come from about Sheffield before us'¹⁵¹. If the Hodgson and his men had felt a strong identification with their current regiment, this transfer would almost certainly have prompted him to record some form of adverse feelings (as he does in other parts of his memoir¹⁵²). In the same way, we have noted above¹⁵³ how the horse officer Richard Atkyns arranged the transfer of his troop from one regiment to another at his men's request. This implies that the *loyalty/identity structure* may have been focused at sub unit rather than at unit level, or at least that there was no consistent focus on the unit level as either *loyalty hot spot* or *residual focus of loyalty*. At the very least such considerations should caution us against applying the model of the *loyalty/identity structure* of the British Army in the twentieth century to seventeenth century British soldiers.

Assessment

It seems clear, therefore, that the model of the *loyalty/identity structure* of the units of the British Army today cannot be applied in any significant detail before the twentieth century without risk of distorting the material to fit the model. However, the concept of a specifically redrawn *loyalty/identity structure* as a means of analysing the daily life of British soldiers at any period may well be useful.

The functional structure

*'I've been in the saddle for hours and hours
I've stuck it as long as I could.
I've stuck it and stuck it and now I say "fuckit!",
My bollocks are not made of wood!'*¹⁵⁴

*'When cannons are roaring
And bullets are flying,
He that should honour win
Must not fear dying.'*¹⁵⁵

In Chapter Three we described the *functional structure* as consisting in the ideas, rules and conventions of behaviour that are connected with carrying out what soldiers see as soldierly tasks. We looked briefly at the nature of those soldierly tasks, the groupings which arise from the *functional structure*, and the attitudes and mental models which soldiers hold concerning soldierly functions. The chosen test for the model in this section is whether or not it can be shown that there existed a distinct set of ideas and attitudes concerning soldierly tasks during the selected historical periods, and whether this set of ideas and attitudes is covered by the model.

In the mid and early twentieth century, the soldiers' functional experience and attitudes seem to have much in common with those of today. Accounts of functional scenes are readily recognisable to those with contemporary military experience. Take, for example, this description of an unofficial roadside drill practised by Gunner Hanbury's light anti-aircraft battery,

'When the convoy pulled into the roadside for the 10 minute check-halt, one man from each Bedford tractor, jumped out to join the line of road sentries across the road. On the roadside, two men filled the square punctured tin with earth, sprinkling it with petrol, lit, to boil the dixie of water for a quick brew-up.

Inside the cabin, bread was quickly sliced, spread with marmite and jam, and before the order "Mount!" everyone had their share, gun-teams, road sentries, sergeants, and officers all doing a stint along with the Don Rs [dispatch riders].

*How the provisions were acquired was nobody's business.'*¹⁵⁶

Hanbury also gives anecdotes in his letters which have as a common thread a comical false confidence on the part of officers in their ability to perform military tasks. For instance, during a battle camp, with instruction from a First World War veteran, Captain Catchpole,

‘In the late afternoon when the Captain was explaining that hedges were not obstacles, but dealt with by charging head on and bursting through, Captain Jameson of B Troop suddenly appeared on the scene and offered to demonstrate the technique to follow - if it was all right by Captain Catchpole.

Captain Catchpole gave a curt nod and burly captain Jameson borrowed a rifle, told us to watch closely, then yelling like a Dervish charged at breakneck speed, unfortunately slipping and losing his momentum about 10 feet from the hedge.

In desperation he swallow-dived into the hedge and when the threshing and struggling finally subdued, all that was visible were two brown boots. In the silence that followed, Captain Catchpole nodded to the two nearest lads to grab a boot each and rescue the red-faced trapped Captain who sheepishly grinned then slipped away. From then on he was nicknamed Captain BB Jameson (Brown Boots).’¹⁵⁷

In the first of these two cases, Hanbury is stressing the smooth teamwork and task knowledge of the disparate elements in the convoy in producing food and drink for all the members, whether they could help in its preparation or not. In the second, he is highlighting the inability of Jameson to meet the military standard that they all subscribe to, a standard of aggression and competence at basic infantry tasks which is still current today.

The existence of a shared fund of ideas and attitudes to soldierly tasks can be inferred from a description by Lucas of feelings that he had detected in British soldiers towards the Germans, which can be explained by using the concept of the *functional structure*, as it presently stands,

‘... the farther removed from the battle line a soldier was the more antagonistic he was to the Germans. ... I have met infantrymen and tankmen who had nothing but praise for the soldierly qualities of our former enemies against whom they had been fighting, in some instances, for many years.’¹⁵⁸

These views are echoed by Shipster throughout his memoir of fighting in Burma and India in the Second World War¹⁵⁹. In spite of being wounded three times and losing a great number of friends, he maintains an attitude of respect towards the Japanese soldiers against whom he fought and he is openly sympathetic to their plight on their desperate withdrawal in 1945.

Using the concept of the *functional structure* we can deduce that, immersed as they were in the business of soldiering, the infantrymen and tankmen's respect for the enemy arose from the fact that they met the same functional standards and shared their preoccupations with the fine detail of soldiering. This contrasted with those in the rear, who had little or no liability to engage functionally with the enemy and to make these functional comparisons.

George Macdonald Fraser gives us another insight into the existence of a shared fund of ideas about the 'right' way to do soldierly tasks when he describes his own incompetence the first time he meets an enemy soldier in Burma 1945. He has just returned to his section after entering two apparently deserted Japanese bunkers alone, and after giving a third a cursory look. The enemy soldier appears from apparently nowhere and attempts to carry out a suicide bombing with a land mine. However, this soldier is killed by another, more experienced, member of the infantry section (Nick) before he can get properly into position. Fraser, 'Jock', is then chided by his colleague Nick,

“Might ha' bin thee, Jock boy. Ye shoulda give us a shout, man.”

I explained why I hadn't, and he shook his head. “Nivver ga in on yer own, son. That's 'ow ye finish up dyin' Tojo's way. Ye wanna die yer own fookin' way.”

“Git fell in, you two!” It was [*sergeant*] Hutton again. “Standin' about matterin' wid yer thumbs in yer bums an' yer minds in neutral!...”¹⁶⁰

This passage gives us two immediate insights into the way that these soldiers addressed function. First, Nick is contrasting his ability with that of Jock, and resorting to a common standard of conduct ('Nivver ga in on yer own'). Then the sergeant contrasts their casual and un-functional behaviour (as he sees it) with the soldierly way that they ought to be behaving. These features are entirely consistent with the *functional structure* in the model.

First hand information from the First World War also indicates a similar preoccupation with functional matters, and no significant difference from the *functional structure* in the model.

We begin with a set of observation reported by Sheffield,

'Pte. S.B. Abbot (86th M.G. Coy.) condemned one of his officers (nicknamed 'The Orphan') as a 'thruster', prepared to endanger his men's lives by unnecessary displays of excess zeal in 'straffing' enemy positions, while simultaneously appearing to be over-concerned for his own safety. Abbot implicitly compared The Orphan with another officer, referred to respectfully as Mr Street, who was 'a splendid man',

a paternalist who was mourned as ‘our brave and kind officer’ when he was killed in April 1917. The essence of leadership is diverting the cohesion of the group into the ends desired by the military hierarchy, but this example demonstrates that if officers are perceived to be too eager to take risks, and thus jeopardise their troops, at the very least they forfeit the respect of their men.’¹⁶¹

These feelings integrate well with those expressed in the 1970s by the soldiers about the ambitious subaltern, Harry Cooper, in their remarks on the walls of the ablutions in Northern Ireland that we looked at earlier¹⁶²: they criticised Cooper’s attempt to establish a reputation as a functionally competent officer by taking unnecessary operational risks.

Private Ernest Atkins provides us with another illustration that sits well with the *functional structure* in the model. He suffered from short sight, but he was highly motivated to become a good soldier and so he had to adopt several coping strategies to get round the military requirements of his initial training in 1914. One of these coping strategies was to claim that he would fire his weapon instead of engaging in bayonet fighting,

‘So I must learn defence against the enemy’s bayonet and shoot him while we are fencing. This does not please the sergeant, who tries all ways to get at me. “Your defence is good but you don’t attack. What’s your idea - to keep him trying to reach you until he drops dead from exhaustion?” I said, “No, but to shoot him while I am fencing. I have shot you many times in imagination.”’¹⁶³

This attitude was logical, but it did not chime with the accepted functional conventions of the time which stressed the importance of the aggressive use of the bayonet in hand-to-hand fighting.

We take an extract from Private David Jones’s poetic autobiography of the First World War as the third and final example from that era of the encoding of function in words familiar today. As part of the description of his battalion’s departure from a training camp in England for France in 1915, Jones quotes a NCO’s words aimed at ensuring that they march in a soldierly fashion,

‘Dress to the right - no - other right.
Keep those slopes.
Keep those sections of four.
Pick those knees up.
Throw those chests out.
Hold those heads up.

Stop that talking.
Keep those chins in.
Left left lef' - lef' righ' lef' - you Private Ball it's you I've got me glad-eye on.'¹⁶⁴

We can see from the first hand accounts of British soldiers of the mid nineteenth century that they too had a shared set of expectations and ideas about how military functions should be carried out, though the nature of these expectations and ideas is less congruent with those of today.

In the first set of examples, Lieutenant General Richard Barter comments on the operations following the break-in to Delhi. We begin with his views about an operation to clear part of the city on 18 September 1857, of which he says, 'It was the most wretchedly managed affair: the column marched up a narrow lane towards the Enemy without even a file of men thrown out to feel the way;'¹⁶⁵. This passage shows that Barter, then a Captain, had a set of ideas about the right way that this function should have been carried out, a standard that was not achieved by the local commander. It is also clear from the way that Barter writes ('wretchedly managed ... without even a file') that he is telling his readers that there were functional conventions (shared sets of ideas) that the commander was not observing.

He is also firmly critical of the ability of the brigade commander, Colonel Edward Greathed, during the pursuit beyond Delhi on 28 September of the same year. Barter writes,

'Greadhed smoothed his moustache and seemed inclined to sit there for ever and let things go on as they were going. ... we were beginning to weary of the thing and were whispering one to another our wonder how long this was to last when a voice from the right of our line answered the question in true Irish fashion by asking another ... as he shouted out, "Arrah are we going to stop here all day? Lit's go and take the bloody battery!" The effect was magical. With a cheer¹⁶⁶ the men and officers jumped to their feet and over the bank we tore, while we could see that the 8th too had caught the infection, and were on the move to our right. Of Greadhed we saw no more that day.'¹⁶⁷

This passage tells of a contrast which appears to be illuminated by the attitudes expectations belonging to the *functional structure*. The brigade commander is incompetent and does nothing. The unnamed Irish soldier calls upon his comrades to take action and they all join in (except Greadhed) with enthusiastic aggression, presumably because it was obvious to them from their shared fund of ideas that this was the right thing to do.

Barter passes similarly critical comments on the ability of one of his colleagues, a few days later during the pursuit after the fall of Delhi,

‘Captain DaCosta, 58th Native Infantry, who ... though a very gallant man was one of the most thoroughly incompetent officers I have ever met; he had not gone far when we saw that as usual he hadn’t an idea how to set about what was required of him, and I was ordered to go and take command. I jumped off my horse, and over the wall into the garden where the two Companies were drawn up as targets for the Enemy, ... [and] I threw out a cloud of skirmishers and swept the orange groves from end to end without however meeting an Enemy, for the Sepoys retreated before us and into the town which now came in sight.’¹⁶⁸

Here the contrast is between DaCosta, gallant but functionally innocent and therefore incompetent, and Barter, who has the necessary functional ability to do the task properly. The one falls below the standards of the proper way to behave on operations, while the other meets them.

Sergeant Gowing expresses the ideas current at the siege of Sebastopol when he remarks that ‘men will go anywhere with officers upon whom they can rely’ and describes the elements that make up such an officer,

‘... old soldiers - men that had been well tried upon field after field from the Alma, and we had a few that had smelt powder on many a hard-contested field in India, such as Ferozeshah, Moodkee, Sobraon, and Gujrat - men that knew well how to do their duty and were no strangers to a musket-ball whistling past their heads, who understood well a live shell in the air and knew within a little where it was going to drop. One feels much more comfortable with such men than with three times their number who have never smelt powder.’¹⁶⁹

From the same campaign, Private James Herbert of the 4th Light Dragoons writes of the fighting during the recovery from the Charge of the Light Brigade,

‘We rushed in amongst them [the Russian counter-attack], and there was renewal of the cutting, slashing, pointing, and parrying of the earlier part of the fight. There was no fancy work, but just hard, useful business, and it fulfilled its object, for we cut our way through the opposing lancers.’¹⁷⁰

Herbert draws a functional distinction between ‘fancy work’ which was not appropriate, and the ‘useful business’ which they employed.

Trumpet-Major Henry Wilkinson of the 17th Lancers gives us another glimpse of what was thought ‘proper’ in battle, remembering the Battle of Ulundi (1879),

‘The Colours were flying and the bands were playing as we advanced, and the sun shone on the glittering bayonets, lances, and rifle-barrels. That was just before we were actually and finally disposed in square, waiting for them to come on; and then, of course, we were silent enough, for we were out for business.’¹⁷¹

We may infer from this paragraph that there was common agreement (stated or unstated) that music and other martial sounds were inappropriate for times when soldiers were ‘out for business’.

Our final example from the mid nineteenth century comes from another cavalry soldier, who passes comment on the lack of importance of musketry to the cavalry in the 1870s, writing ‘... for some years musketry, was universally hated and deemed to be a degradation and a bore.’¹⁷² This statement, which would be somewhat surprising if were expressed in any part of today’s British Army, can be explained by the fact that musketry was an essentially dismounted activity, and did not fit with the cavalry’s shared mental model of ‘proper’ fighting, which was to be done on horseback with lance and sword.

In the Napoleonic period, we can see again that function was an important area of preoccupation among British soldiers. We begin with a comparison made by General Sir Thomas Brotherton between the soldierly business of operations in the forward area in the Peninsular War and the life of a civilian in Wellington’s headquarters. The occasion for this comparison was the publication by Sir George Larpent of his ‘private journal’ as Wellington’s Judge-Advocate¹⁷³. Brotherton says of Larpent,

‘His functions were confined strictly to the closet, and he had no business whatever to poke his nose in danger, ... I could not resist the temptation of giving this ‘quill-driver’ my opinion, not only as to the folly of such persons coming, ostentatiously, to the front, but as to the mischievous effect on the *morale* of the troops, by their precipitate retreat when they became frightened for, although the soldiers heartily laughed at these *amateurs*, yet, at such moments, anything that diverts the attention of troops from what ought to be their only object, viz the enemy, is hazardous.’¹⁷⁴

Here we see a contrast between what Brotherton sees as proper soldierly conduct, which is devoting one’s concentration to the enemy in a professional way, and the conduct of the

'amateur' who comes forward ostentatiously, and distracts the people who ought to be there. It is clear that Brotherton does not claim this as a personal idiosyncratic view, but holds it up as the proper way that a soldier ought to think. Such a view can only be based on a mental model of a shared standard of proper soldierly conduct.

Sergeant Morley provides us with an interesting insight into his defining attitudes to soldiering and soldierly qualities. He was taken prisoner by the French during the retreat to Corunna in 1808, and subsequently escaped and made his own way back to Portugal in a complex and difficult journey, showing considerable personal courage and determination. His successful arrival back at British-held territory could legitimately have been a source of pride to him, but the thing he notes with most emphasis in his memoir is the moment when he was issued with arms and accoutrements *'and thus once more had a regimental home'*¹⁷⁵. Here we see that Morley uses the issue of arms and accoutrements as the symbol that he is once more a full member of his *'regimental home'* and thus fully a soldier again, implying that a soldier is defined by his ability to fight (or in the present phrase, *'do the business'*). This seems to take precedence over his escape and subsequent journey which cannot therefore have been as functionally important to him as his re-achievement of the status of soldier.

To continue the theme of what constitute soldierly tasks and the exercise of soldierly status, Major Harry Ross-Lewin relates a source of serious discontent among the soldiers in garrison at Corfu in 1819, when they were used as navvies,

*'... owing in part to their being substituted for horses at the government works, and compelled to draw stone and rubbish-carts; they had, besides, to discharge the stone, both by day and night, from the vessels, according as they arrived with it from Malta. Such duty should never have been imposed on them Such treatment has a manifest tendency to degrade soldiers in their own estimation, and to break that spirit which it should be a commanding officer's care to foster and encourage.'*¹⁷⁶

It is clear that Ross-Lewin's emphasis is first on the nature of the work rather than the effort required of the soldiers. He identifies it as of a non-soldierly nature, and therefore degrading. We may speculate with some confidence, however, that he would not be likely to disapprove in the same way of military operations that required the same degree of energy expenditure from the soldiers.

Our final example from the Napoleonic period confirms the existence of a shared view that soldierly performance was an important ingredient in the status of the individual soldier, an important element in the *functional structure* as we saw in Chapter Three¹⁷⁷. In his account of the Battle of Vimero in 1808, Rifleman Benjamin Harris tells a comrade, John Lowe,

“... if you see any symptoms of my wishing to flinch in this business, I hope you will shoot me with your own hand.”

Lowe and myself survived this battle, and after it was over we sat down with our comrades and rested. Talking over various matters, Lowe told them of the conversation we had during the heat of day. From that moment, the Rifles had a great respect for me. A man is closely observed in the field, and it is indeed singular how, from his behaviour, a man loses or gains caste with his comrades.¹⁷⁸

These words show us that prowess at military tasks was an important element in a soldier's status, as Killworth has shown is the state of affairs today¹⁷⁹. This can only be the case if the soldier and his peers all subscribe to the same shared view of what constitutes functional prowess.

The evidence from the mid eighteenth century shows a similar general concern with military function, how the job should be done, and where the expertise could be expected to lie. In our first illustration, Sub-Brigadier [the most junior commissioned rank in that Regiment] Richard Davenport comments on his activities as Adjutant of the Fourth Troop of Horse Guards, a post he has recently been appointed to,

‘The morning is more than sufficient to do all my business, but an adjutant is expected to be always what they call “alert”, that is to say, he must always appear in a great hurry, or at his commanding officer's elbow, ready to execute his commands. In all these things I am very cavy [alert]¹⁸⁰, for I take care not to neglect anything of consequence. My Colonel does not give me any unnecessary trouble.’¹⁸¹

In making these amusing remarks, Davenport is playing with ideas and expectations concerning the functions an adjutant. The humour lies in the fact that his declaration that he has embraced them is made simultaneously with the implication that he is in fact only pretending to do so. However, these remarks would make no sense, and would contain only idiosyncratic humour if those expectations or attitudes were not generally shared by his fellow-soldiers.

Our second and third illustrations from the mid eighteenth century are from the perspective, respectively, of a company commander and a NCO. The company commander, Captain John Peebles, draws upon his knowledge and expectation of how things should be done when he passes adverse comment on the quality of the work of the junior officers,

‘Saturday 27th. [March 1779] ... went to the parade & look at the Companys arms & dress which I believe is rather neglected by the Subs. - the young Gentlemen of the army at present are much fonder of their pleasure than their duty’¹⁸²

While the NCO, Sergeant Roger Lamb, looks back at his initial training as a recruit in 1773,

‘[I] was put into the hands of a drill sergeant, and taught to walk and step out like a soldier. This at first was a disagreeable task to me. ... However, having at last rectified the most prominent appearance of my awkwardness, I received a set of accoutrements, and a firelock’¹⁸³

In both cases, the writers are expressing elements of the common set of values concerning military function, the first by showing how the young officers are falling below proper functional standards, and the second by reporting his transformation from the *habitus* of a civilian to a soldierly one, marked by the issue of warlike equipment.

In the next example, Mattross James Wood records how engineers were put in charge of *ad hoc* parties from different foot regiments on 26 September 1746,

‘... several parties of different regiments drawn up in order to work at the repairs of our battery, being sunk in some places two foot or more, and very much shattered with the French firing all day. Our engineers settled the Foot to work on enlarging the trenches.’¹⁸⁴

The implication is that these engineers had the necessary expertise for the task and so it was natural for them to take charge of troops over whom they had no authority in the *formal command structure*.

Finally, Hospital Assistant William Fellowes of the 37th foot gives us a glimpse of the pull of military soldierly activity at the Battle of Minden in 1769,

‘The soldiers and others, this morning, who were not employed at the moment, began to strip off and wash their shirts, and I as eagerly as the rest. But while we were in this state, suddenly the drums began to beat to arms: and so insistent was the summons that without more ado we slip’t on the wet linen and buttoned the jackets

over the soaking shirts, hurrying to form line lest our comrades would depart without us.¹⁸⁵

Here we see Fellowes describing a swift transition from informal to functional activity. It is interesting that he gives as his motivation the need to take part in the battle with his comrades, rather than the, presumably, serious disciplinary consequences of being absent from the battalion at a moment of action. This points to a primacy in this situation of the need to carry out soldierly business.

The seventeenth century material also yields evidence that soldiers had shared ideas about military function, and gave credit to those with expertise. A useful illustration is provided by Hodgeon's summing up of Colonel Bright, the commander of the regiment to which his company had been regrouped in 1645, as, 'He was but young when he first had the command; but he grew very valiant and prudent, and had his officers and soldiers under good conduct.'¹⁸⁶ We can see that in contrasting Bright's initial state of less than full functional competence with his subsequent highly competent state, Atkyns is highlighting valour and prudence as important functional virtues. We may therefore infer that these qualities formed an important element in general ideas about functional quality in a commander.

Hodgson provides us with another illuminating case. This is an incident during battle in 1648, when he arrives to give new orders from the general to a foot regiment (Ashton's) that was still forming up,

'I met with Major Jackson, that belonged to Ashton's regiment, and about three hundred men were come up; and I ordered him to march, but he said he would not, till his men were come up. A serjeant, belonging to them, asked me, where they should march? I shewed him the party he was to fight; and he, like a true bred Englishman, marched, and I caused the soldiers to follow him; which presently fell upon the enemy, and, losing that wing, the whole army gave ground and fled. Such valiant acts were done by contemptible instruments!'¹⁸⁷

Hodgson's contrast of the conduct of Major Jackson and the sergeant show the sergeant as meeting basic functional standards more completely than the major. However, by use of the word 'contemptible' Hodgson emphasises the junior status of the sergeant in the *formal command structure*. In essence therefore, this passage draws a distinction between rank in the *formal command structure* and functional competence.

Nehemiah Wharton's letters also give us an insight into functional elements of the soldier's lives of the time. In the first, we hear of a military review,

'Wednesday Sept. 14th [1642], our forces, both foot and horse, marched into the field, and the Lord General viewed us, both front, rear and flank, when the drums beating and the trumpets sounding made a harmony delectable to our friends, but terrible to our enemies.'¹⁸⁸

This passage shows that drums and trumpets were necessary elements in conducting formed military operations.

In the second Wharton writes of a regimental training session,

'Friday our regiment was commanded to meet here again to be mustered, were we exercised in the field the whole day, and the muster master came not, whereat we were all much displeased.'¹⁸⁹

The displeasure of the troops is a strong and obvious indication that the muster master was expected to attend the muster by the functional conventions of the time.

Finally, we have a description of an incident on operations,

'Thursday morning we marched in the front four miles towards Worcester, where we met one riding post from Worcester, informing us that our troops and the cavaliers were there in fight; ... Upon this report our whole regiment ran shouting for two miles together, and crying "To Worcester, to Worcester," and desired to march all night.'¹⁹⁰

We can see here that the unit of which Wharton was a member has a shared attitude of aggression towards the enemy and a shared convention that closing with them was the most appropriate thing to do.

Assessment.

We can see from the foregoing that throughout the periods discussed there existed an identifiable set of mental models concerning, and attitudes to, tasks and behaviour that fit the category 'soldierly'. Military function is a strong thread that runs through the entire history of the British Army. The reason is not difficult to determine, because military function has always been an essential element in its *raison d'être*, and it should come as no surprise that soldiers of all periods show that they hold ideas and attitudes concerning military function. Nor is it surprising that these ideas and attitudes form a significant part of their daily experience and expectations and that they expressed opinions about their ability and that of their fellow-soldiers to perform military functions. We may therefore deduce that the model of the *functional structure* has passed the first element of its test, which, it will be recalled was whether a distinct set of mental models concerning, and attitudes to, soldierly tasks could be identified in the historical material.

The second part of the test was whether or not the sets of ideas and attitudes towards function identified in the various historical periods are as depicted in the *functional structure* element of the model.

On the one hand, some of the extracts quoted above seem surprisingly close to what might be the case today. Davenport's remarks on the expectation that an adjutant will appear to be busy, for instance, and Peebles' critical remark about young officers both appear timeless, and such things might be held to argue for a commonality between the *functional structure* described in Chapter Three and the functional awareness, attitudes and mental models of earlier periods. However, the same cannot be said of all the material that we have seen in this section concerning function. Although the attitudes and expectations expressed in the accounts quoted above are clearly to do with military function, and although they have in common with the model a positive and professional attitude to the military task, the nature of the task and its basic elements differ so markedly from those of today that they fall well outside the model. Fieldcraft, for instance, was scarcely an issue for most soldiers before the Boer War, and the fine detail of expert use of sword and lance were no longer relevant after mechanization had been completed in the 1930s. Further back in time, it need scarcely be

argued that the skills required of an infantry soldier of the Napoleonic era and earlier were of a different nature to those of today, or that the drums and trumpets which Wharton noted in 1642 have no place in military function today.

These considerations can be made clear if we revisit Rifleman Harris's account of the Battle of Vimero quoted on page 283 above. We noted that Harris and his peers shared a common set of rules about the importance of defining military prowess, and that this prowess consisted in the ability not to flinch, above all else. Lack of fear was apparently rated higher than skill at arms or knowledge of minor tactics, which would not be the case in the light of today's functional values.

Our judgement must be therefore that the concept of a functional structure of some kind encapsulates many of the attitudes and actions recorded by British soldiers of earlier times, and can probably act as a convenient gateway through which to assess their mental models, but the model of the *functional structure* derived for soldiers of today does not adequately fit.

We may conclude, then, that the model of the *functional structure* has clear weaknesses when applied to historical material, and this deficiency indicates a satisfactory degree of internal rigour.

Result of test One: Does the model reflect the behaviour of British soldiers from the mid twentieth century back to the mid seventeenth century?

This section has shown that a model of four social structures in combat arms units of the British Army can be constructed from the historical material in all the selected eras, but in many cases as soon as the current model is brought to bear in detail on the patterns of soldiers' behaviour outside the present period it does not fit the material convincingly. The trend, as we have seen, is for the current model to diverge progressively from the historical material the further back in time it is applied, and this feature can give us confidence that the model is sufficiently rigorous to be sensitive to time and context.

The main exceptions to this trend are the elements of the *informal structure* which were tested, the existence of *legitimate* and *illegitimate secondary adjustments* and the

sub-model of informal relationships. Both aspects appear to match the evidence of the first hand accounts throughout all the periods investigated.

The existence of *secondary adjustments* may reasonably be assumed in any human system which is constrained by formal rules, and the distinction between *legitimate* and *illegitimate secondary adjustments* is a natural consequence of a rank and discipline structure that puts individuals in a position to decide what to permit and what rules to enforce. In creating the term ‘secondary adjustments’, Goffman¹⁹¹ was giving a name to a common human activity, and in making the distinction between ‘legitimate’ and ‘illegitimate’ I have captured an important feature in agents’ perceptions. These terms help to explain the conditions under which these activities take place, and the behaviour that results from confusion between the categories. To this extent, then, the concepts in question are a wider human phenomenon, not confined to the present-day British Army, or to Goffman’s American mental patients in the mid twentieth century. Their existence in any model of British (and presumably other) soldiers’ behaviour in any era is therefore necessary. Their general applicability is not a sign of any weakness in that part of the model.

Of the five-fold suite of relationships which comprise the sub-model of informal interaction, only the most distant and insignificant, *nodding acquaintance*, appears to be absent from the historical material, and as this is the least constrained or demanding of them it may reasonably be assumed to exist in a recognisable, if uncelebrated, form in any era. The existence of warm informal relationships between peers in any historical period should not concern us because they are self-evidently a common feature of human experience. However, the apparent general applicability of the elements in the sub-model concerned with cross-rank informal relationships is more problematical because it is out of step with received wisdom on the subject of officer-man relationships in the more distant past, as we discussed above. Nevertheless, we have seen here that there is sufficient evidence to sustain the argument that the current framework of cross-rank informal relationships has existed for at least 250 years, and maybe longer. If that is the case, as I believe it to be, then the persistence of this part of the model through time is a reflection of the persistence of the aspect that it models, and not an artificiality in the model.

Although this finding is a by-product of the testing of the model, and therefore off the main route of this chapter, it deserves further study elsewhere. A particular focus of such a study could well be a comparison of the detailed elements of these relationships in different historical periods: the analysis of the degree of deference expected from the junior participant in *association*, for example, may well reveal specific differences in that relationship between, say, the mid eighteenth and early nineteenth centuries.

So far, we have examined historical material in the light of the model to test the model's applicability to it. In the next section we will look briefly for wider issues that are not captured by the model but had significant influence on the ways that British soldiers organised and conducted themselves towards each other.

SECTION THREE - TEST QUESTION TWO: ARE THERE SIGNIFICANT ASPECTS OF THE BEHAVIOUR OF BRITISH SOLDIERS OF THE PAST THAT ARE NOT REVEALED OR ILLUMINATED BY THE MODEL?

Having applied the model directly to first hand material from British soldiers in the past, we are now going to examine influential aspects of the lives of those soldiers that the model does little or nothing to illuminate. It will be sufficient for the purpose of this chapter - to test the model - simply to demonstrate that such aspects exist, without the necessity of attempting a comprehensive record of all of them.

Primed by Stevens's analysis of the importance of 'gentlemanliness' in the specific context of the nineteenth century Rifle Brigade¹⁹², we are going to consider three further influences from the wider British society, though on a larger scale than just one regiment. Two are from the nineteenth century and earlier, and one is from the early twentieth century. These are the concept of personal honour, the practice of duelling, and some of the social effects on the British Army of its very rapid expansion in the First World War.

Honour

In the earlier periods examined in this chapter, the concept of personal honour had a greater significance than it has today. Individuals were very concerned with preserving it intact and untarnished, and it is a recurring and strong theme in the first hand material that survives to us. However, it did not appear as an issue in the interview material from the current British Army, which indicates that it is no longer a primary concern. It therefore is not reflected strongly in the model.

A typical example of personal honour as an issue in the seventeenth century is given by Captain Richard Atkyns in his description of the debate as to the status of his lieutenant in 1643. This officer had been captured by the enemy and allowed his liberty on parole, according to normal practice. However, he had been rescued by his own side whilst still on parole, and the debate was about whether or not his parole still applied after his rescue,

‘The case was agreed to be “whether a prisoner upon his parole to render himself to the enemy, being afterwards redeemed by his own party, ought to keep his parole or not”. His Lordship heard arguments on both sides; at last said thus, that there had been lately a precedent in the Council of War in a case of like nature, wherein it was resolved, that if the prisoner (being redeemed by a martial power without any consent of his own) shall afterwards refuse the command he was in before and attempt to render himself prisoner to the enemy, he shall be taken as an enemy, and be kept prisoner by his own party; the reason seems very strong because he may be prevailed upon by the enemy to betray his own party; and the freeing of his person, gives him as it were a new election; and if he choose rather to be a prisoner than a free man; it demonstrates his affection to be there. But this did not satisfy my Lieutenant, for he would not take his place as before, but marched along with the troop as my prisoner, till the taking of Bristoll (the place where he promised to render himself) and then he thought he was fully absolved from his parole, and betook himself to his employment again.’¹⁹³

The lieutenant clearly felt that his own interpretation of the code of honour took precedence over the decisions of his commander, even if they were made in the light of apparently the same code of honour. Atkyns himself must have had sympathy for his lieutenant’s point of view because he assisted him in taking him along as his ‘prisoner’.

Odintz deals at some length with the eighteenth-century British officer's concept of personal honour, showing that it was a daily preoccupation, and a significant one in their daily lives, policed by their peers¹⁹⁴, for example,

'Rough or elegant, sociable or anti-social, all officers shared a common obsession with the most personal element of the honor code, that of preserving one's reputation.'¹⁹⁵

'In situations where an officer was believed to have violated the honor code, rather than a specific Article of War, the initiative for dealing with the offender usually lay with his peers in the regiment rather than with the senior officers, the means chosen to deal with him by his fellows were usually much less formal in their initial stages, and the legal system was only utilized if the offender failed to respond adequately to less public pressures. The most common of these informal sanctions was social and professional ostracism. The officers of the regiment would refuse to serve with, "roll" with or dine with an officer who had violated the honor code.'¹⁹⁶

Nor was the concept of personal honour entirely an officer's prerogative. An other ranks' perspective is provided by two further examples, from the Peninsular War. First, there was a general willingness among soldiers to volunteer to be members of the 'forlorn hope' in sieges, which seems remarkable today. It was the task of this forlorn hope to be the first troops in the assault, and few of them were expected to survive¹⁹⁷. However, forlorn hopes were always oversubscribed several times over with volunteers¹⁹⁸. In the case of the forlorn hope for the storming of San Sebastian in 1813, for instance, this involved the selection of the party from numerous volunteers by drawing lots,

'... an order was given to every regiment in our division to send one serjeant, one corporal, and twenty privates, to assist in storming this strong place. I volunteered as soon as I heard the order read. An old corporal, John Styles by name, stammered out "A-a-a- an' I'll g-g-g-go too." In a few minutes ten serjeants, and old Styles, volunteered as stormers. We assembled at the colours, and drew lots.'¹⁹⁹

Second, here are Sergeant Anton's remarks about those who fail their test of courage,

'A man may drop behind in the field, but this is a dreadful risk to his reputation, and even attended with immediate personal danger, while within the range of shot and shells: and wo [*sic*] to the man that does it, whether through fatigue, sudden sickness, or fear; let him seek death, and welcome it from the hand of a foe, rather than give room for any surmise respecting his courage; for when others are boasting of what they have seen, suffered, or performed, he must remain in silent mortification. If he

chances to speak, some boaster cuts him short; and, even when he is not alluded to, he becomes so sensitively alive to these merited or unmerited insults, that he considers every word, sign, or gesture, pointed at him, and he is miserable among his comrades.’²⁰⁰

This passage chimes well with the general attitude expressed by Rifleman Harris above as to the priority of unflinching courage.

The categories in the model as it stands do not lead us to identify personal honour as a specifically defined and special area of concern that dominated soldiers’ attitudes and personal conduct. The most that can be said, using the model of the present day alone, is that honour should show up as a preoccupation in the *informal structure*, or possibly as a feature in the *functional structure*, but there is nothing to suggest, for instance, that *secondary adjustments* in the area of honour might not be tolerated at any level.

It seems best to view the concept of personal honour as a cultural element affecting the wider British society in former times to such an extent that British soldiers considered it a natural part of life, a view that chimes with Odintz’s statement that,

‘While the outward manifestations of [the gentlemanly] ... code varied somewhat among the elites of the Anglo-American world, the primacy of honor as the well spring of gentlemanly behavior, and the right and duty of a gentleman’s peers to pass judgement on the honorableness [*sic*] and correctness of his actions, were accepted principles throughout British society, and indeed throughout the Western world.’²⁰¹

It could be said that it was imported naturally into the Army as part of the *habitués* of those who joined it. Its lack of prominence in the model indicates therefore that the model is not sensitive to such general cultural elements outside the current period. This lack of sensitivity in the model is an important feature that ties it to the present day and makes it fail when it is applied without adjustment to previous eras.

Duelling

Duelling in the British Army was intimately bound up with the concept of personal honour among officers, and flourished especially in the eighteenth century. However, it also took place in the seventeenth century and was still a generally persistent, if formally forbidden, aspect of life in Wellington's Army, only withering away as common practice in the mid nineteenth century.²⁰²

Symonds gives us three examples of duelling, between two of the King's captains of horse, between the Earl of Peterborough and a Captain Willoughby, and between a lieutenant of horse and an unnamed trooper.²⁰³ The last case is interesting in that it appears to represent a duel between individuals of widely different social classes, which would not have been the case in the eighteenth century when duelling was confined to 'gentlemen', as Odintz shows us in his comprehensive analysis of duelling among the officers of the eighteenth century British Army²⁰⁴.

We may conclude from Odintz's analysis that duelling was formally forbidden in the mid eighteenth century but that it was also expected behaviour. This provided a clash between rule and expectation that Gilbert explores in his paper on law and honour in the eighteenth century British Army,

'The eighteenth-century army officer was caught between two conflicting modes of behaviour. To some extent he was torn between the past and the future. Personal defence of one's honour was giving way to the more dispassionate, and less bloody, legal resolution of disputes, but the relationship between the two was unclear.'²⁰⁵

It might be argued that this conflict between rule and practice provides us with a classic case of the *illegitimate secondary adjustment*. However, it was generally expected by the overwhelming majority, including members of the chain of command, that an officer would defend his honour to the extent of duelling to conserve it. It could scarcely therefore fit the category of *illegitimate secondary adjustment* if the chain of command supported it. However, it could not be called a *legitimate secondary adjustment* either, because of the near certainty of formal disciplinary action if an officer seriously hurt his opponent. Duelling was therefore in a special category of its own which is missing from the model and would have to be inserted to make it useful in describing, analysing and explaining officers' behaviour

in the eighteenth century, and probably in the seventeenth and early nineteenth centuries as well.

The requirement for officers to defend their personal honour by duelling therefore represents another area where the model is not sensitive to cultural elements in the wider society that intruded into the social fabric of the British Army. This lack of sensitivity would have to be compensated for by the insertion of specific amendments to the model for the periods in question.

Rapid expansion

The needs of the First World War in terms of military manpower dwarfed Britain's military resources in 1914, and there was a consequent surge in numbers of men joining the Army. As Holmes points out, this rapid expansion involved over five and a half million men (slightly over 22 per cent of the adult male population of the United Kingdom) during the course of the war, from a starting regular strength in 1914 of less than 250,000 men.²⁰⁶ This unprecedented expansion drew individuals into the British Army who would have had no intention of joining under the pre-war conditions, men like those described by Captain Ivar Campbell from France in a letter written in 1915, as 'little fellows from shops, civilians before, now and after ...'²⁰⁷. Furthermore, in many cases the social backgrounds of officers and other ranks were not the traditional ones. As Holmes has put it,

'The British regular army tended to mirror the social structure of Edwardian England, its officers drawn largely from traditional elites and its rank and file soldiers disproportionately representing the urban unemployed. But the volunteer New Armies, raised in response to Kitchener's call to arms, were a far less accurate reflection, and thousands of well-educated men served in the ranks. ... Conscription broke down even more traditional barriers, and in 1917-18 there were many middle-class men serving in the ranks. There is no easy correlation between rank and social class in the British army of the First World War.'²⁰⁸

Because the overwhelming majority of British soldiers in the First World War thus came from a much wider social base than before, and because there was this novel mixture of classes, it seems inevitable that there must have been significant differences in the social fabric of the First World War army, compared to that of 1913, which would have been reflected in

the ways in which the soldiers behaved. Indeed, Sheffield provides us with a specific illustration in the way that the supposedly global apparatus of discipline was applied in different units, by distinguishing between 'regular' and 'auxiliary' modes of discipline in the New Army battalions,

'Regular modes of officer-man relations and discipline were simply inappropriate. A Regular brigadier described the discipline of 6/W. Yorks as being that of 'good will', while Hurst wrote of the 'comradeship' which produced an 'easy relationship between officers and men...[which] was the despair of the more crusted Regular martinet', a form of discipline which was maintained without requiring 'the banishment of individuality and of the exercise of intellect from Regimental life'.²⁰⁹

This distinction between different modes in the application of the apparatus of discipline was obviously a reflection of the different nature and origins of the types of unit in question. However, this distinction is not easily picked up in the model, which simply captures the existence and structure of a common apparatus of rank and discipline. It does not discriminate between regular and auxiliary types of unit simply because it was constructed in an environment where there is only one type of unit, those of the regular combat arms.

Faced with a requirement to analyse the data which Sheffield has brought forward here, the best that can be done, using the model exclusively, would be to say that the *informal structure*, and particularly the relationship of *association*, was often used in preference to the firm lines of the *formal command structure* in the New Army battalions. Although that may tell us something useful about how discipline was applied, and we may be able better to visualise the process using the model, it can tell us nothing about the reasons for, or background to, this different emphasis in different types of unit.

In the same way, the model is too crude a device to give us a proper insight into the lives of individuals who had neither the ability nor willingness to be integrated into the military environment but found themselves in it because of the circumstances of war. It would be possible to use the model's category of *rogue agent* to describe such misfits, but this categorisation would not be adequate to encapsulate their behaviour or attitudes, which fall well outside the implicit assumption in the model that members of the Army embrace soldiering. A particular case in point is that of Private Alfred Hale, a well educated and quiet man of private means who had achieved modest distinction as a composer. He was

conscripted into the Army in 1917 at the age of 38, found not to be fully fit, and was employed as a batman in the Royal Flying Corps for two years. His memoir²¹⁰ is a tale of misery, misunderstanding and confusion, and we can see him progressively losing his dignity and self respect as it proceeds.

Result of test two: identification of aspects of the behaviour of British soldiers of the past that are not revealed or illuminated by the model

These three sets of examples show us, therefore, that the model has no capacity to allow for powerful cultural factors from outside the Army that significantly affect soldiers' attitudes, assumptions and behaviour. Nor can it distinguish the particular effects of rapid and significant changes in the social composition of the Army.

SECTION FOUR - CONCLUSIONS

I had earlier believed²¹¹ that the model worked well in the analysis and understanding of first hand accounts by British soldiers of all eras since the mid seventeenth century. However, I have had seriously to revise this conclusion during the research for this thesis. There are, indeed, certain areas where the fit remains good for a considerable period back in time, and at the top level the model provides a useful set of categories for all periods as we will examine further in the next chapter. However, the more detailed research reported in this chapter has shown that the model has significant limitations when applied in the historical context. In the first place, it does not fit some of the first hand evidence, and in general the lack of fit in the model becomes more pronounced the further back in time it is tested. We saw this in the clear differences from the selected aspects of the *formal command structure* in the seventeenth century, the differences from the *loyalty/identity structure* in the eighteenth century and earlier, and the differences in the attitudes and expectations expressed about the ingredients of military function in the mid nineteenth century and earlier. Secondly, the model misses some important historical cultural issues which impinged on soldiers' lives from the wider British society.

It can therefore be said with confidence that the model is not so plastic that it fits all cases and that it can be assumed to have sufficient rigour to be acceptable for its purpose, this purpose being the description, analysis, and prediction of the behaviour of current British Army soldiers in combat arms units. We can say that it has passed its test.

However, we have also seen that certain aspects of the model do indeed fit British soldiers behaviour and attitudes at least as far back as the eighteenth century, and possibly further. Particular cases are the concepts of *legitimate* and *illegitimate secondary adjustments* and the five-fold sub-model of informal relationships. Given that the model has been shown to have rigour in other areas, this suggests that the testing of the model has detected persistent cultural aspects of life in the British Army over a considerable period of time. We will address this implication in the next chapter when we consider the future uses to which the model, or variants of it, might be put in examining contemporary and historical issues in the British Army at unit level.

Notes to Chapter Five:

¹ Editor's introduction to Dean, J., *A Journal of Marlborough's Campaigns During the War of the Spanish Succession 1704-1711* (Chandler, D. (ed.)), Society for Army Historical Research Special Publication No 12, 1984, p. vii.

² Todd, W., *The Journal of Corporal Todd 1745-1762* (Cormack, A. and Jones, A. (ed.)), Stroud: Sutton Publishing Limited for the Army Records Society, 2001.

³ Personal communication with Andrew Cormack, co-editor of Todd's Journal, 30 January 2002.

⁴ McGuffie, T., *op. cit.*, p. xxi.

⁵ From Anon., 'The Rogues March', mid nineteenth century, Winstock, L., *Songs & Music of the Redcoats: A History of the War Music of the British Army 1642-1902*, London: Leo Cooper, 1970, p. 97.

⁶ From Anon., 'The Little Harness Room Across the Square', early twentieth century, Wright, Major D., RA/UH, 1 December 1996, and others.

⁷ McNeill, W., *The Pursuit of Power: Technology, Armed Force, and Society since A.D. 1000*, Oxford: Basil Blackwell, 1983, pp. 117-143.

⁸ Bellamy, C., D., 'Rank', in E. R. Holmes (ed.), *op. cit.*, 2001, pp. 755- 759.

⁹ Milligan, S., *Adolf Hitler: my Part in his Downfall*, Harmondsworth: Penguin Books Ltd., 1972, p. 112.

¹⁰ See for example, the editor's introduction to Wood, J., *Gunner at Large: The Diary of James Wood R.A. 1746-1765*, Whitworth, R. (ed.) London: Leo Cooper, 1988, p. x.

¹¹ See for example, Houlding, J., *Fit for Service: The Training of the British Army, 1715-1795*, Oxford: Clarendon Press, 1981, p. 101.

¹² See for example, Davenport, R., *To Mr Davenport: Being the Letters of Major Richard Davenport (1719-1760) to his Brother During Service in the 4th Troop of Horse Guards and 10th Dragoons, 1742-1760* (Frearson, C. (ed.)), Society for Army Historical Research Special Publication No. 9, 1968, p. 5.

¹³ See Holmes, E. R., *op. cit.*, 2001, pp. xviii-xx for a clear summary of rank and unit structure in the eighteenth and nineteenth centuries. See also Houlding, J., *op. cit.*, pp. 90-95.

¹⁴ See, for example, *Rules and Articles for the Better Government of his Majesty's Horse and Foot Guards, and all others his land-forces in Great Britain and Ireland and dominions beyond the sea*, London, 1737, cited in Gilbert, A., 'Law and Honour Among Eighteenth-Century British Army Officers', *The Historical Journal*, **19**, 1976, pp. 75-87, this p. 79.

-
- ¹⁵ Wood, J., *op. cit.*, pp. 138-139.
- ¹⁶ Todd, W., *op. cit.*, p. 16.
- ¹⁷ Symonds, R., *The Complete Military Diary* (Peachy, S. (ed.)), Leigh-on-Sea: Partizan Press, 1989, p. 53.
- ¹⁸ Hodgson, J., *Memoirs of Captain John Hodgson of Coalley-Hall, Near Halifax; Touching His Conduct in the Civil Wars, and his Troubles After the Restoration. Written by Himself*, Pontefract: Gosling Press, 1994, p. 23.
- ¹⁹ Bellamy, C., 'Military Revolutions', in Holmes, E.R. (ed.), *op. cit.*, 2001, pp. 587-588.
- ²⁰ Bellamy's citations include: 'Black, Jeremy, *A Military Revolution? Military Change and European Society 1550-1800* (London, 1991)', 'Parker, Geoffrey, *The Military Revolution: Military Innovation and the Rise of the West, 1500-1800* (Cambridge 1989), and 'Roberts, Michael, 'The Military Revolution 1560-1660' (1956), repr. in *Essays in Swedish History* (London, 1967), 195-225'.
- ²¹ Bellamy, C., 'Military Revolutions', in Holmes, E.R. (ed.), *op. cit.*, 2001, p. 587.
- ²² From Anon., 'Sergeant Goode's Song', mid twentieth century, Kirke, Colonel, R., RA/UH, 2 February 1999.
- ²³ From untitled song, mid twentieth century, recollected by Wolsey, Major H., RA/UH 25 September 1996.
- ²⁴ From Ravenscroft, T., 'The Owl', 1609, sung by British soldiers for at least 150 years. See Winstock, L., *Songs & Marches of the Roundheads and Cavaliers*. London: Leo Cooper, 1971, p. 39.
- ²⁵ Lucas, J., *Experiences of War: The British Soldier*, London: Arms and Armour Press, 1989, p. 25.
- ²⁶ Sheffield, G., *op. cit.*, pp. 195-196, citing '[Burrage A.B.] 'Ex-Pte. X', *War is War*, London: 1930, p. 74.'
- ²⁷ Campbell, C., *Letters from Camp to his Relatives During the Siege of Sebastopol*, London: Richard Bentley and Son, 1894, pp. 105.
- ²⁸ Pearsall, J. (ed.) *op. cit.*, p. 315.
- ²⁹ Barter, R., *The Siege of Delhi: Mutiny Memoirs of an Old Officer*, London: The Folio Society, 1984, p. 70.
- ³⁰ See the strictures on looting given out before the attack on Delhi quoted in Griffiths, C., A

Narrative of the Siege of Delhi with an Account of the Mutiny at Ferozepore in 1857 (Yonge, H. (ed.)), London: John Murray, 1910, pp. 143-144, and 227-228.

³¹ Morley, S., *Memoirs of a Serjeant of the 5th Regt. of Foot, Containing an Account of his Service in Hanover, South America, and the Peninsula*, Cambridge: Ken Trotman Ltd., 1999, pp. 108-109.

³² Odintz, M., *op. cit.*, 1988, p. 419.

³³ Stepler, G., *op. cit.*, 1984, pp., 85-88.

³⁴ A formal gathering of commanders, and in this case by implication a disciplinary hearing roughly equivalent to the later Court Martial.

³⁵ Atkyns, R., 'The Vindication of Richard Atkyns', in P. Young (ed.), *The Civil War*, London: Longmans, 1967, pp. 7-32, this p. 14.

³⁶ Hanbury, Gunner J., RA/UH, 18 May 1999.

³⁷ Sliepmann, *Echo of the Guns: Recollections of an Artillery Officer 1914-18*, London: Robert Hale, 1987, p. 44.

³⁸ *Ibid.*, p. 45.

³⁹ Waterfield, R., *The Memoirs of Private Waterfield, Soldier in Her Majesty's 32nd Regiment of Foot (Duke of Cornwall's Light Infantry) 1842-57* (Swinson, A. and Scott, D. (ed.)), London: Cassell, 1968, p. 61.

⁴⁰ Anton, J., *Retrospect of a Military Life During the Most Eventful Periods of the Last War*, Cambridge: Ken Trotman, 1991, p. 31.

⁴¹ Lamb, R., *Memoir of His Own Life*, Dublin, 1811, p. 74. Stepler *op. cit.* pp. 88 and 89 shows us that this sort of behaviour was a general phenomenon not restricted to Lamb's regiment.

⁴² Wharton, N., 'The Letters of Nehemiah Wharton', in S. Peachey (ed.), *The Edgehill Campaign and the Letters of Nehemiah Wharton*, Leigh-on-Sea: Partizan Press, 1997, pp. 5-27, this p. 9.

⁴³ Moynihan, M. (ed.), *People at War 1914-1918* Newton Abbot: David & Charles, 1973, p. 58.

⁴⁴ Lang, A. M., *Lahore to Lucknow: the Indian Mutiny Journal of Arthur Moffatt Lang*, London: Leo Cooper, 1992, p. 168.

⁴⁵ *Ibid.*, p. 170.

⁴⁶ Gowing, T., *Voice From the Ranks: A Personal Narrative of the Crimean Campaign by a Sergeant of the Royal Fusiliers (edited by K. Fenwick)*, London: William Heinemann Ltd.,

1954, pp. 20-21.

⁴⁷ Morley, S., *op. cit.*, p. 100.

⁴⁸ Odintz, M., *op. cit.*, p. 562, citing SRO GD26/9/513/5, 'Extract from Lt Armstrong, 17th ft [sic].'

⁴⁹ Milligan, S., *Monty: His Part in My Victory* (Hobbs Jack (ed.)), Harmondsworth: Penguin Books, 1978, p. 9.

⁵⁰ Hanbury, Gunner J., RA/UH, 9 December 97.

⁵¹ Brander, M. (ed.), *The Sword & The Pen* London: Leo Cooper, 1989, p. 130.

⁵² Jones, D., *In Parenthesis: seinyessit e gledyf ym penn mameu*, London: Faber & Faber Ltd., 1963, p. 145.

⁵³ Lloyd, A., *The War in the Trenches*, London: Book Club Associates, 1976, p. 159.

⁵⁴ Campbell, C., *op. cit.*, 1894, p. 81.

⁵⁵ Griffiths, C., *op. cit.*, p. 16.

⁵⁶ Barter, R., *op. cit.*, p. 109.

⁵⁷ Evernden, G. W., 'Diary', in G. Moore (ed.), *Three Chose War*, UK: Privately published by Geoffrey Moore, 1978, pp. 7-26, this p. 16.

⁵⁸ Cooper, J. S., *Rough Notes of Seven Campaigns in Portugal, Spain, France and America During the Years 1809-1815*, Staplehurst: Spellmount, 1996, p. 68.

⁵⁹ *Ibid.* p. 18.

⁶⁰ Pattison, L. F. H., *Personal Recollections of the Waterloo Campaign, in a Series of Letters to his Grand-Children*, Pontefract: Gosling Press, 1992, p. 34.

⁶¹ Davenport, R., *op. cit.*, pp. 20-21.

⁶² Peebles, J., *John Peebles' American War 1776-1782* (Gruber, I. (ed.)), Stroud: Sutton Publishing Limited for the Army Records Society, 1998, p. 254.

⁶³ Todd, W., *op. cit.*, p. 55.

⁶⁴ *Ibid.*, p. 79.

⁶⁵ *Ibid.*, p. 117.

⁶⁶ According to Tucker's Introduction to his *Military Memoirs* (Young, P. and Tucker, N. (ed.), *Military Memoirs: the Civil War* London: Longmans, Green and Co. Ltd., 1967, p. 40,) Gwynne 'scorns dates'.

⁶⁷ Gwynne, J., *Military Memoirs of the Great Civil War, being the Military Memoirs of John Gwynne; and an account of the Earl of Glencairn's Expedition, as General of His Majesty's Forces, in the Highlands of Scotland, in the Years 1653 & 1654 by a person who was eye and ear witness to every transaction. With an Appendix.*, Cambridge: Ken Trotman Ltd., 1987, p. 136.

⁶⁸ Wharton, N., *op. cit.*, p. 12.

⁶⁹ See, for example, Sweet, R., *The English Town, 1680-1840: Government, Society and Culture*, New York: Pearson Education Inc., 1999.

⁷⁰ Milligan, S., *op. cit.*, 1978, p. 19.

⁷¹ The date is not given in the text from which this passage is quoted. However, from the context it is either 1943 or 1944 and the likelihood is that it is the latter.

⁷² Fraser, G. M., *Quartered Save Out Here: a Recollection of the War in Burma*, London: Harvill, 1992, p. 29. The sergeant was working up to telling the soldier that he had been selected for a more dangerous position in the platoon.

⁷³ Sheffield, G., *op. cit.*, 1994.

⁷⁴ *Ibid.*, p. 14, citing Mosley, O., *My Life*, London, 1968, pp. 47-48.

⁷⁵ *Ibid.*, p. 198, citing Hamond, D., *Wisdom for Warts*, p. 9, D. Hamond papers, Liddle Collection, University of Leeds Library.

⁷⁶ *Ibid.*, p. 250, citing Griffith, W., *Up to Mametz*, London, 1981, pp. 135-136.

⁷⁷ Mills, J., *For King and Country: the Letters and Diaries of John Mills, Coldstream Guards, 1811-1814* (Fletcher, I. (ed)), Staplehurst: Spellmount Ltd., 1995, pp. 12-13.

⁷⁸ Odintz, M., *op. cit.*, p. 466.

⁷⁹ Gilbert, A. N., *op. cit.*, p. 85.

⁸⁰ Hopkins, J., 'Sergeant John Hopkins, Grenadier Company, 97th Regiment', in J. Lewis, E. (ed.), *The Mammoth Book of War Diaries & Letters: life on the battlefield in the words of the ordinary soldier, 1775 -1991*, London: Robinson, 1998, pp. 224-229, this p. 225.

⁸¹ Smith, G. L., *A Victorian RSM: From India to the Crimea*, Tunbridge Wells: Costello, 1987, p. 54.

⁸² Brotherton, T., *A Hawk at War* (Perrett, Brian (ed.)), Chipenham: Picton Publishing,, 1986, p. 11.

⁸³ Cooper, J. S., *op. cit.*, p. 88.

⁸⁴ Odintz, M., *op. cit.*, p. 447, citing Jervis, J., *Three Centuries of Robinsons*, New York, 1967, p. 91.

⁸⁵ The text of the Davenport's letter and Frearson's footnote both appear in Davenport, R., *op. cit.*, p. 81.

⁸⁶ Odintz, M., *op. cit.*, p. 409, quoting 'The Memoir of John Dorman', *The Gentleman's Magazine* Vol. LXXXIX, p. 131, Feb. 1819.

⁸⁷ Gruber, I., in Peebles, J., *op. cit.*, p. 14.

⁸⁸ Todd, *op. cit.* p. 14.

⁸⁹ *Ibid.*, p. 16.

⁹⁰ *Ibid.*, p. 20.

⁹¹ Wharton, N., *op. cit.*, p. 11.

⁹² Gwynne, J., *op. cit.*, 1987, p. 132.

⁹³ Lucas, J., *op. cit.*, pp. 115-116.

⁹⁴ Bowlby, A., *The Recollections of Rifleman Bowlby*, London: Cassell, 1999, pp. 109-110.

⁹⁵ Sheffield, G., *op. cit.*, pp. 191-192, citing Hamond, D., *op. cit.*, p. 3.

⁹⁶ Barter, R., *op. cit.*, p. 23.

⁹⁷ Gowing, T., *op. cit.*, pp. 76-77.

⁹⁸ Cooper, J. S., *op. cit.*, p. 10.

⁹⁹ Morley, S., *op. cit.*, p. 42.

¹⁰⁰ This means the light infantry company of his battalion (the 42nd Foot).

¹⁰¹ Peebles, J., *op. cit.*, 1998, pp. 187.

¹⁰² Todd, W., *op. cit.*, pp. 104-105.

¹⁰³ *Ibid.*, p. 105.

¹⁰⁴ Atkyns, R., *op. cit.*, p. 8.

¹⁰⁵ From Anon., 'Old King Cole', *circa* 1930, Jervis, Lieutenant Colonel A., RA/UH, 9 October 1996.

¹⁰⁶ From Martin, C., 'The Connaught Rangers', late nineteenth century, Winstock, L., *op. cit.*, 1970, p. 235.

¹⁰⁷ Kingsland, G., *In Quest of Glory*, Sevenoaks: Hodder and Stoughton, 1990, p.126.

¹⁰⁸ Fraser, D., *And We Shall Shock Them: The British Army in the Second World War*, London,: Hodder and Stoughton, 1983, pp. 88.

¹⁰⁹ Lucas, J., *op. cit.*, p. 23.

¹¹⁰ Hanbury, Gunner J., RA/UH, 12 February 1998.

¹¹¹ Hanbury, Gunner J., RA/UH, 9 December 1997.

¹¹² Hanbury, Gunner J., RA/UH, 27 April 1999.

¹¹³ Lucas, J., *op. cit.*, p. 100.

¹¹⁴ As part of their identity, light infantry regiments march at a faster pace than other regiments. To achieve this pace they have to take shorter steps and to an observer this resembles a fast, short stepping, trot.

¹¹⁵ Lucas, J., *op. cit.*, p. 24.

¹¹⁶ Laffin, J., *Letters from the Front 1914-1918*, London: J.M. Dent & Sons Ltd, 1973, p. 62.

¹¹⁷ Sheffield, G., *op. cit.*, p. 180, citing Chell, R., 'My First Command - Service with an Essex Battalion', *Essex Countryside*, December 1972, p. 41.

¹¹⁸ At this time, 'brigade' in the artillery referred to unit level (batteries under a HQ).

¹¹⁹ Sliepmann, *op. cit.*, p. 33.

¹²⁰ Atkins, E., 'A Few Tales of 1914-18', in Moynihan, M. (ed.), *People at War 1914-1918* Newton Abbot: David & Charles, 1973, pp. 85-104.

¹²¹ *Ibid.*, p. 85.

¹²² *Ibid.*, p. 89.

¹²³ The date of this remark is not given by Moynihan. However, from the context it appears to have been early in the war.

¹²⁴ Evelyn, G., *A Diary of the Crimea* (Falls, C. (ed.)), London: Gerald Duckworth & Co Ltd, 1954, p. 119.

¹²⁵ Gowing, T., *op. cit.*, p. 10.

¹²⁶ They had not yet been issued with rifles and were one of the last infantry battalions using the musket.

¹²⁷ Barter, R., *op. cit.*, p. 73.

¹²⁸ Jocelyn, S., *With the Guards we Shall Go: A Guardsman's Letters in the Crimea 1854-1855* (Airlie M. (ed.)), London: Hodder and Stoughton Limited, 1933, p. 72.

¹²⁹ Ross-Lewin, H., *With "The Thirty-Second" in the Peninsular and Other Campaigns*, Cambridge: Ken Trotman Ltd, 2000, p. 129. The date of this remark is given as 1809.

¹³⁰ Anton, J., *op. cit.*, pp. 282-283.

¹³¹ Hennell, G., *A Gentleman Volunteer: The Letters of George Hennell from the Peninsular War 1812-1813* (Glover, M. (ed.)), London: Heinemann, 1979, p. 13.

¹³² *Ibid.*, pp. 14-15.

¹³³ Cited in Odintz, M., *op. cit.*, p. 14, as 'Howard, Michael, *Studies in War and Peace* (New York, 1972), pp. 97-98'.

¹³⁴ Odintz, M., *op. cit.*, p. 17.

¹³⁵ It seems that what Odintz means by 'primary groups' here is the body of the battalion rather than the smaller 'primary groups' explored by Janowitz (see Chapter Four pages 222 to 225).

¹³⁶ *Ibid.*, p. 18.

¹³⁷ Cited in *Ibid.*, p. 390, as 'Wilson, *Wolfe*, p. 298, James Wolfe to Hugh Lord, undated'.

¹³⁸ Todd, W., *op. cit.*, pp. 239 - 251.

¹³⁹ *Ibid.*, p. 251.

¹⁴⁰ Wharton, N., *op. cit.*, p. 15.

¹⁴¹ These men came from Sir Henry Chomley's Regiment, fellow Parliamentarians.

¹⁴² Atkyns, R., *op. cit.*, p. 12.

¹⁴³ Hopton, R., *Bellum Civile: Sir Ralph Hopton's Memoirs of the Campaign in the West, 1642 - 1644* (Wicks, A. (ed.)), Leigh on Sea: Partizan Press, 1988, p. 47.

¹⁴⁴ Symonds, R., *op. cit.*, p. 52.

¹⁴⁵ See, for example, the letter dated 26 September 1642, Wharton, N., *op. cit.*, p. 17.

¹⁴⁶ See Wood, S., 'Grenadiers', in Holmes E.R. (ed.), *op. cit.*, 2001, p. 378, and Holmes, E.R. 'Flank Companies', in *ibid*, p. 304.

¹⁴⁷ Peebles' career is set out in the editor's introductions to the various chapters of Peebles, J., *op. cit.*

¹⁴⁸ Peebles, J., *op. cit.*, p. 75.

¹⁴⁹ *Ibid.*, p. 100.

¹⁵⁰ *Ibid.*, p. 276.

¹⁵¹ Hodgson, J., *op. cit.*, p. 8.

¹⁵² We have already seen in this chapter, for instance, Hodgson's record of the men's refusal to accept the man proposed as their new commanding officer (page 256).

¹⁵³ Page 284.

¹⁵⁴ From Anon., 'The Dispatch Rider's Lament', circa 1940, Turner (Captain?) S., RA/UH, 14 October 1996.

¹⁵⁵ From Anon., 'When Cannons are Roaring', mid seventeenth century, Winstock, L., *op. cit.*, 1971, p. 43.

¹⁵⁶ Hanbury, Gunner J., RA/UH, 12 February 1998.

¹⁵⁷ Hanbury, Gunner J., RA/UH, 22 October 1999.

¹⁵⁸ Lucas, J., *op. cit.*, p. 56.

¹⁵⁹ Shipster, J., *Mist on the Rice-Fields: A Soldier's Story of the Burma Campaign and the Korean War*, Barnsley: Leo Cooper, 2000.

¹⁶⁰ Fraser, G. M., *op. cit.*, p. 9.

¹⁶¹ Sheffield, G., *op. cit.*, pp. 222-223, citing 'S.B. Abbot papers, 78/36/1, IWM, 28-30 April 1917'.

¹⁶² See Chapter Four, page 191.

¹⁶³ Atkins, E., *op. cit.*, p. 87.

-
- ¹⁶⁴ Jones, D., *op. cit.*, pp. 3-4.
- ¹⁶⁵ Barter, R., *op. cit.*, p. 67.
- ¹⁶⁶ The ‘cheer’ seems to be important in the functional structure. It is a shout of aggression and redolent of ‘doing the business’.
- ¹⁶⁷ *Ibid.*, p. 78.
- ¹⁶⁸ *Ibid.*, p. 84.
- ¹⁶⁹ Gowing, T., *op. cit.*, pp. 105-106.
- ¹⁷⁰ Herbert, J., ‘The Charge of the Light Brigade’, in Knight, I., (ed.), *Marching to the Drums: Eyewitness Accounts of War from the Kabul Massacre to the Siege of Mafikeng*, London: Greenhill Books, 1999, pp. 35 to 43, this p. 40.
- ¹⁷¹ Wilkinson, H., ‘The Fight for Natal’, in Knight I. (ed.), *op. cit.*, pp. 258-265, this pp. 262 - 263.
- ¹⁷² Robertson, Sir W., quoted in McGuffie, T., *op. cit.*, p. 82.
- ¹⁷³ Larpent, G., *The Private Journal of Judge-Advocate Larpent, Attached to the Head-Quarters of Lord Wellington During the Peninsular War, from 1812 to its Close*, London: Richard Bendley, 1854.
- ¹⁷⁴ Brotherton, T., *op. cit.*, pp. 29-30. Original emphases.
- ¹⁷⁵ Morley, S., *op. cit.*, p. 85.
- ¹⁷⁶ Ross-Lewin, H., *op. cit.*, pp. 349-350.
- ¹⁷⁷ See Chapter Three, page 121.
- ¹⁷⁸ Harris, B., *op. cit.*, p. 62.
- ¹⁷⁹ Killworth, P., *op. cit.*, 1997, pp.114-123.
- ¹⁸⁰ i.e., ‘cavee’, or on the look-out, from the Latin, ‘cave’.
- ¹⁸¹ Davenport, R., *op. cit.*, p. 27.
- ¹⁸² Peebles, J., *op. cit.*, p. 254.
- ¹⁸³ Lamb, R., *op. cit.*, pp. 61-62.
- ¹⁸⁴ Wood, J., *op. cit.*, p. 21.

-
- ¹⁸⁵ Holmes, E. R., *op. cit.*, 2001, p. 22, citing Hargreaves, R. *This Happy Breed: Sidelights on Soldiers and Soldiering*, London: 1951, p. 42.
- ¹⁸⁶ Hodgson, J., *op. cit.*, p. 8.
- ¹⁸⁷ Hodgson, J., *op. cit.*, p. 14-15.
- ¹⁸⁸ Wharton, N., *op. cit.*, p. 17.
- ¹⁸⁹ *Ibid.*, p. 17.
- ¹⁹⁰ *Ibid.*, p. 18.
- ¹⁹¹ Goffman, E., *op. cit.*, 1968.
- ¹⁹² Stevens, C., *op. cit.*
- ¹⁹³ Atkyns, R., *op. cit.*, pp. 27-28.
- ¹⁹⁴ Odintz, M., *op. cit.*, pp. 492-574. See also Brumwell, S., *Redcoats: The British Soldier and War in the Americas, 1755-1764*, Cambridge: Cambridge University Press, 2002, pp. 89-91.
- ¹⁹⁵ Odintz, M., *op. cit.*, p. 508.
- ¹⁹⁶ *Ibid.*, p. 571.
- ¹⁹⁷ Siege techniques in the Peninsular War, including the role of the forlorn hope are described in Myatt, F., *British Sieges of the Peninsular War*, London: Guild Publishing, 1987, pp. 8-15.
- ¹⁹⁸ See Haythornthwaite, P. J., *The Napoleonic Source Book*, London: Arms and Armour, 1995, p. 114, and Holmes, E. R., 'Forlorn Hope', in Holmes E. R. (ed.), *op. cit.*, 2001, p. 306.
- ¹⁹⁹ Cooper, J. S., *op. cit.*, pp. 100-101.
- ²⁰⁰ Anton, J., *op. cit.*, p. 77.
- ²⁰¹ Odintz, M., *op. cit.*, p. 492.
- ²⁰² Holmes, E. R., *op. cit.*, 2001, pp. 284-288.
- ²⁰³ Symonds, R., *op. cit.*, pp. 15, 16, and 76.
- ²⁰⁴ Odintz, M., *op. cit.*, pp. 508-536.
- ²⁰⁵ Gilbert, A. N., *op. cit.*, p. 86.
- ²⁰⁶ Holmes, E. R., *The Western Front*, London: BBC Worldwide Ltd., 1999, pp. 52.

²⁰⁷ Laffin, J., *op. cit.*, 1973, p. 10.

²⁰⁸ Holmes, E. R., *op. cit.*, 1999, pp. 11-12.

²⁰⁹ Sheffield, G., *op. cit.*, p. 45, citing Tempest, E., *History of the 6th Battalion West Yorkshire Regiment*, Bradford: 1921, p. 6, and Hurst, G. *With the Manchesters in the East*, Manchester: 1917, p. 2.

²¹⁰ Hale, A., *The Ordeal of Alfred M. Hale: The Memoirs of a Soldier Servant* (Fussell, P. (ed.)), London: Leo Cooper, 1975.

²¹¹ Kirke, C., *op. cit.*, 1994, and Kirke, C., *op. cit.*, 2000.

CHAPTER SIX - USES OF THE MODEL TO EXAMINE HISTORICAL AND CONTEMPORARY ISSUES

SECTION ONE - INTRODUCTION

The aim of this thesis has been to ‘present a model generated using social anthropological techniques, which can be used with a degree of confidence to describe, analyse and predict the behaviour of British soldiers in regular combat arms units in the current British Army’ (Chapter One, page 3). This aim has been met. It now remains for us to look for ways in which this model might be used in the future, building on the work presented so far.

Two principal areas will be explored. First, building on the findings of the previous chapter, we will examine how existing elements or variants of the model might be used to gain a better understanding of British soldiers at regimental duty in the past. Secondly, we will look at certain specific issues that are of concern to the British Army of today.

The emphasis of this chapter is on identifying promising areas for future work, rather than presenting a fully-researched and argued picture of any particular area. However, where possible, and where relevant, elements of the research conducted for this thesis will be brought forward to shed light on particular aspects.

SECTION TWO - THE PAST

A General Unifying Framework for Analysis

We have seen in Chapter Five that the model cannot be applied uncritically to describe, analyse and explain British soldiers’ behaviour in all eras. This implies that specially constructed, time-specific, models would be required for each historical context to take account of detailed features of behaviour in that context and of powerful influences from the wider British society that were specific to that era. However, at no stage in Chapter Five was it necessary to amend the overall four-fold construction at the top level of the model, of *formal, informal, loyalty/identity, and functional structures*. Even where significant time-

specific aspects were found, such as in the *loyalty/identity structure* of the eighteenth century or in the *functional structure* before the First World War, it was apparent that the four basic elements of the model still provided a suitable analytical structure. It is possible, therefore, to use these top level elements as a unifying framework with which to consider the British Army throughout his history, whilst adapting the lower levels as necessary to deal with particular eras or contexts.

We also noted in the last chapter that the model's typology of informal relationships provided a useful characterisation of informal interactions in British Army units well back into the past, and so it, too, may be used with confidence in analysing historical material.

We will now examine the use of the top level of the model, and where appropriate the typology of informal relationships, to enhance our understanding of British Army issues in the past in four different ways. In the first, we examine its use as a check list to guide the historian to examine all aspects of a military context, in the second we explore its use as a means to test the genuineness of what purports to be first hand material, in the third we consider it as a means to detect and track change and observe continuity, and finally we examine two apparent paradoxes.

In all that follows, the overall use that the selected elements of the model offer is the improvement of our understanding of the social milieu inhabited by the soldiers whose experiences we are examining, and the reasons for their particular behaviour. In essence, the model provides a way of penetrating what Cobbett called 'the Secrets of the Army' which he likened to 'those of Free Masonry; it is absolutely necessary to become a brother of the blade before you can become at all acquainted with the arcania [*sic*] of the profession'¹.

A Check List of Factors

An important element of any historical study is the need to provide a balanced and appropriate analysis. When the subject is British soldiers, such an analysis would be greatly helped by the check list of significant areas provided by the top level of the model, the headings of the four *social structures*. This check list provides a gateway through which to approach the material and to increase the likelihood that enquiry is made into all the significant

factors that would have influenced the behaviour and attitudes of the protagonists. The three examples which follow illustrate this point.

Example One: Baynes's analysis of morale in the 2nd Scottish Rifles in 1915

In *Morale: a Study of Men and Courage*², Baynes analyses the motivation of the men of the 2nd Scottish Rifles at Neuve Chapelle in 1915. As part of his exploration of the pre-war background of the soldiers concerned, when they were stationed in Malta, he sums up the factors motivating their behaviour as follows,

‘One should think of the Privates of the 2nd Scottish Rifles in Malta, therefore, as men of many varied types, with numerous different facets to their characters, but held together by toughness of spirit, strong discipline, and most important of all, fierce loyalty to the Regiment. This last quality cannot be over-emphasized - it is essential to realize that it was the strongest single influence on the lives of everyone in the battalion.’³

and he restates his view of the importance of loyalty to the Regiment in his comments on the conduct of the battalion in battle,

‘But if anyone wants to know what was the quintessence of the morale of the pre-1914 Army - what was the rock of its foundation - then the answer is the Regiment. Everything else was important, but if the actions of the soldiers of the Scottish Rifles at Neuve Chapelle are to be explained in a few words one can only say that they did it for the Regiment.’⁴

Use of the top level of the model leads us to question the balance in this analysis. In the first place, we may observe that Baynes has included at most only three of the four structures in making his case. ‘Strong discipline’ belongs to the *formal command structure*, and ‘fierce loyalty to the Regiment’ belongs to the *loyalty/identity structure*. ‘Toughness of spirit’ could probably be mapped onto the *functional structure*, but there is no mention here of the *informal structure*, and in particular the horizontal and vertical bonds of *friendship, association and informal access* which, as the model indicates, provide strong personal threads within a unit. Secondly, in focusing monolithically on the Regiment as the locus of loyalty, Baynes here neglects the influence of the other levels in the *loyalty/identity structure*.

These omissions are all the more surprising because Baynes clearly identifies all the missing elements in his text, as the following extracts show.

Taking the *informal structure* first, and using the typology of relationships, we can see in this first extract that he is obviously aware of the importance of what is modelled as *friendship*,

‘Two men who had become mates or “muckers” in the Army were closer to each other than most brothers, and often developed a joint identity so that no sensible N.C.O. would dream of telling one to do a job without detailing the other at the same time.’⁵

and in this second that he is aware of rank-asymmetrical informal relationships when he gives a delightful portrait of an informal relationship between a platoon commander, Lieutenant Kennedy, and one of his soldiers,

‘It is interesting to note that Kennedy had a Private Mason in his platoon, whom he describes as a “great gaunt Clydesider”, who had rejoined as a reservist after several years out of the Army working in the mines. There he had become involved with some men of violent Communist opinions and at times in the trenches he would tell Kennedy of what he and his friends would do to the capitalists and bosses after the War. It was blood-curdling stuff, in spite of which Mason was a most loyal and willing soldier, and went out of his way to almost mother Kennedy, and to give him cups of tea and extra rations at frequent intervals. Apparently officers of his own Regiment were exempt from the fury of his class-hatred.’⁶

This portrait contains some of the typical signs of *association* set out in Chapter Three (pages 100 to 102). The officer and the soldier spend a great deal of time together and speak of matters well outside the immediate military situation, and the soldier looks after the officer’s material needs whilst the officer seems to have shielded the soldier from any disciplinary consequences of his anti-establishment views. Furthermore, this was no isolated case: Baynes subsequently lists ‘the excellent officer-other rank relationship’ as an important ingredient in the battalion’s morale in his overall summary towards the end of the book⁷.

He was also aware of the importance of the other levels in the *loyalty/identity structure* apart from the Regiment, and the dynamic quality of these different foci for loyalty,

‘Trust in the group is an essential part of the soldier’s development. At the lowest levels the individual is dependent on his immediate fellows to an extraordinary degree. A private soldier in action finds that his section becomes the centre of his life. He find his platoon and company important as well, and as far as reputation is concerned he thinks occasionally about the battalion and division he is in.’⁸

This brief critique, using the top level of the model as a check list, has therefore shown that Baynes’s analysis is focused too strongly on the Regiment and he has missed the significance of other important factors in spite of observing them.

Example Two: the collapse of the 63rd Regiment in the Crimea

We now turn to a unit whose morale was the very opposite of the Scottish Rifles. Mawton has made available to us the letter written by the Commanding Officer of the 63rd Foot, Lieutenant Colonel The Honourable Robert Alexander George Dalzell, in which he attempts to explain why his battalion had ceased to be effective in the Crimea in January 1855⁹. Dalzell had taken over command of the battalion after it had lost its commanding officer and many of its NCOs at the Battle of Inkerman where it did well, fighting ‘like fun’¹⁰. There is a *prima facie* case for concluding that the new commanding officer must have been incompetent, in the light of the unit’s success under his predecessor and its collapse under him. This case is embraced by Mawton, who says,

‘The Peter Principle was not defined in an aphorism until the 1960s, but Dalzell’s command of the 63rd (The West Suffolk) Regiment of Foot is a superb example of a man being promoted to the level of his own incompetence.’¹¹

The top level of the model allows us to make a balanced adjudication of the case for Dalzell’s defence, put in his letter, which, taken from Mawton’s article, is reproduced in Appendix E with my comments inserted into the text. All of those comments were generated by use of the top level of the model, and, in brief, they show that Dalzell had very real problems in all four *social structures*:

Formal Command Structure. Dalzell's position in the *formal command structure* was weak, and he did not have a strong chain of command to shore it up.

- He had only recently been appointed Commanding Officer, after a popular and successful predecessor, and had been appointed at a time when conditions were difficult. He was therefore bound to appear less capable than his predecessor.

- There was inconsistency in the application of discipline by the officers. This inconsistency would have lowered the expectations of the soldiers about disciplinary standards.

- There was a shortage of experienced NCOs, especially after the battalion's losses at Inkerman. The means to instil and maintain discipline was therefore weakened.

Informal Structure. Many of the positive, bonding, elements of the *informal structure* were missing, whereas negative ones had grown up:

- There was a persistent habit among the soldiers of carrying out *illegitimate secondary adjustments*, even to the extent of harming their own colleagues. This behaviour would have diminished the trust between officers and men, and between peers.

- The regiment had lost its camp kettles during the advance on Sevastopol, which led to the break-up of the soldiers' informal eating groups. This would have removed one of the important vehicles for *friendship*.

- The shortage of NCOs reduced the informal channels of communication between the officers and their men.

Loyalty/Identity Structure. Again, many of the elements that might have provided forces for bonding and cohesion in the *loyalty/identity structure* were missing.

- The officers had mixed, or at best diluted, loyalty as many of them had recently transferred in from other regiments.
- There was a lack of any feeling of competition with other regiments. The benefits of the desire to be 'the best' or of being superior to other units were lost.

Functional Structure. There was no sense of operational purpose in the unit.

- The officers had displayed a marked lack of attention to operational matters. This would have lessened the importance of 'doing the business' in the eyes of the soldiers.
- Survival had become the focus of activity rather than fighting the enemy.

We may speculate as to whether a different individual would have been able to retain the coherence of the battalion, and we may note that in places Dalzell appears both peevish and miserable (neither of which properties would have been valued in a commanding officer). However, the balanced and neutral view provided by use of the model leads us to conclude that Dalzell's problems were both genuine and serious. No *social structure* offered him any firm ground from which to achieve a restoration of confidence and discipline among his soldiers, so, whatever he tried to do it was unlikely to succeed. It would have required a truly exceptional man to retain the control that he lost. Use of the model shows us that Dalzell was right to claim that the situation was a special case, and there is no real indication that Mawton is right to say that he was especially incompetent. The most we can say is that he was not truly exceptional.

Example Three: the interpretation of historical texts

The model is also useful in a more general sense as a guide to the interpretation of historical texts by making us aware of the powerful influence of what are modelled as *social structures* on the attitudes and expectations of individual soldiers. So, for example, when we are told by Odintz that,

‘In 1776 Lady Sarah Lennox praised the collective character of her brother’s regiment, the 25th, to a friend by writing that “I have heard (and indeed seen in some degree) that all the officers are remarkable for their good conduct in every respect: their principles, their friendship, their generosity, manners - and many for their learning - and all for their military and humane turn.”’¹²

the model would guide us to be suspicious of this insider’s view of a Regiment. Lady Sarah Lennox may pass these remarks on as fact, but the model makes us aware that her brother was bound to say good things about his Regiment, by the conventions of the *loyalty/identity structure*. We should be similarly suspicious when Odintz tells us in the same passage that,

‘The diary of Thomas Hughes of the 53rd contains descriptions of the other regiments he came in contact with in Canada in the 1780’s, in which he lists the collective attributes of their officer corps. The officers of the 65th were “all young men, great martinets, but so completely germanised both in dress and manoeuvres that it was some time before we could think them our brother soldiers.”’¹³

and that Hughes’s opinion of the officers of the 34th was that they were, ‘high living wastrels, who “keep horses, give balls and races, and gamble”’¹⁴. In both cases we may view these diary entries somewhat differently, even if we accept that they were written in good faith, if we accept that the influence of the *loyalty/identity structure* is likely to encourage Hughes to think of his Regiment as in some ways superior to the ones about which he is writing.

Such considerations provide us with a useful corrective against accepting as fact the opinion of a soldier on the members of another unit. Although the 53rd (Hughes’s own Regiment) comes out as better than the others in Hughes’s diary, we may consider it likely, for example, that the members of the 65th and the 34th believed that their Regiments were superior to the 53rd, and we would expect to see a different picture of all three units if members of each had left us their views.

Conclusion

These three examples from three different centuries have demonstrated the practicality of using the top level of the model to produce a check list of factors for historical analysis, and the extra insights to be gained from doing so.

Testing for Authenticity

We may also use the model to explore the genuineness of what appear to be diaries or memoirs written by soldiers. Letters written by soldiers to those with no military experience would be excluded from this test because, as we noted in Chapter Two (page 68) the authors might naturally exclude mention of soldierly concerns. However, if the text of a journal or memoir does not have within it indications of four areas of preoccupation matching the four *social structures* then its genuineness should at least be questioned. On the other hand, the presence of material consistent with the four *social structures* would be evidence that such a text is genuine.

A particular case is the well-known anonymous memoir, *A Soldier of the 71st*, which purports to have been written by a private soldier in 1818, covering the period 1806 to 1815¹⁵. The author is only identified by the initials 'T.S.', and by the name 'Tom' used in the text. Reid has pointed out that the muster rolls of the 71st Foot show that the events described in the memoir could not all have been experienced by the same individual, and concludes that the memoir was probably written by 'a man named Howells ... [who] did not himself serve in the 71st, but he may very well have ghosted and heavily "improved" T.S.'s genuine reminiscences'¹⁶.

If we apply the model to this memoir, we may examine its authenticity in a novel way. Scrutiny of the book reveals that many of the features that the model predicts are present. Orders are given and received, and there is a background of discipline and authority (*formal command structure*). The functions of a light infantry soldier are well described (both skirmishing and in close order), as are the minor tactics of Napoleonic British infantry (*functional structure*), and there are several allusions to T.S.'s peers (and in particular to an

individual, Donald M'Donald, who may well have been a *close friend*) that are consistent with the expected behaviour from that part of the *informal structure*. However, there are aspects missing from the memoir which the model indicates should be present. In particular, most of the military activities are reported on the large scale, listing the activities of the various regiments and of distinguished commanders, but little is given of the activities of the constituent parts of the 71st itself or of its officers. There are no allusions to any particular company, and only very occasional allusions to the identity or span of command of any of the officers. Furthermore, the only conversations reported between the officers and the men take place during battle, and no cross-rank informal relationships appear at all. The activities, attitudes, or characters of NCOs are not featured.

Aspects of the *loyalty/identity structure* and the *informal structure* which the model predicts should be present are therefore missing, and this should lead us at the very least to question the memoir's authenticity. However, its immediacy is obvious. It is packed with incidents that are exciting and interesting, capturing both the heroic and the dreadful aspects of the Peninsular War and giving the clear impression of eye-witness accounts. Moreover, where they can be checked, apart from the individual career of 'T.S.' the events described all appear to be genuine, or at the least fully consistent with other contemporary accounts.

These considerations point in two divergent directions: the genuine spirit of the eyewitness accounts of particular incidents is at variance with the lack of full compatibility with the model. This is entirely consistent with Reid's hypothesis: someone has taken some detailed and genuine information from at least one soldier who was on the spot and woven a narrative out of it. However, because of the missing elements, we may add to Reid's findings that use of the model indicates that it is unlikely that the editor was himself a soldier.

Detecting and Tracking Change and Continuity

We noted in Chapter Five that some aspects of the lives of British soldiers in the past were so different from those of today that the model does not have the capacity properly to represent them. Therefore, for a complete tracking of the *social structures* through the British Army's history, several different, time-specific, versions of the model would need to be created. Where such models differed in specific areas, these differences would provide us with a means to track significant changes, and, conversely, lack of differences would indicate areas of continuity.

We have already seen an example of the power of the model to throw changes into relief when we examined the *formal command structure* in the seventeenth century, in Chapter Five (pages 231 and 232). Significant differences between the seventeenth century *formal command structure* and that of the eighteenth century were indications of the 'military revolution' which took place over that period.

Another example concerns the concept of personal honour, a further aspect which we examined in Chapter Five (pages 291 to 295). We saw that it was a significant element in British soldiers' lives of the eighteenth century and early nineteenth century but has lessened in importance between then and now. Therefore, a model of the *social structures* in the eighteenth century British Army would have to include a specific element to account for the primacy of personal honour, while the model of the *social structures* of the Army in the late twentieth century does not include such an element. This implies that a succession of time-specific models covering the intervening years would show us over what period of time the importance of personal honour diminished, what other aspects changed over the same period, and help us investigate how they may be linked.

The production of a series of models capturing *social structures* in the British Army through time would enable us not only to track changes but also to recognise and identify factors that have remained relatively unchanged. Again, we have already started this process in Chapter Five, by remarking on the continuity of the use of *secondary adjustments* over 350 years and of the appropriateness of the typology of informal relationships over at least 300 years (pages 233 to 239, 260, and 288 to 289).

A specific instance is the long history of a particular use of cross-rank informal relationships. We will see from the following cases, spanning 200 years, that the same elements of the present model capture the situation: a subordinate by-passes an awkward superior using an existing informal relationship with a more senior individual.

The first is the case from the recent past of the 'Difficult Sub Unit Commander' in Chapter Four (pages 174 to 176) in which a company sergeant-major, unable to move his company commander, spoke directly to the RSM, using an existing informal relationship. It will be recalled that the RSM went to the Commanding Officer and shortly afterwards the company commander's behaviour changed.

This case has remarkable similarity to others at different time periods. One of them has already appeared in Chapter Five, a case in the Second World War in which a corporal went to his company commander to warn him that one of the company subalterns was not the hero that he was thought to be (page 256). The following are further examples from earlier periods. The first comes from the First World War,

'Sergeant Noble ... has told of a small incident shortly after the battalion arrived in France in 1914. At this stage it was thought that spies behind the British lines might be sending information to the Germans by carrier pigeon. The order therefore came from G.H.Q. for troops at the front to watch out for pigeons crossing their lines in the direction of the enemy trenches. Noble's story is this:

Newly arrived officers sometimes seemed to treat N.C.O.s as inferior. One morning I was posting a sentry, day duty in the trench, and I said "Keep a sharp look out for pigeons." The officer went "Ha, ha", the sentry likewise. I felt humiliated. I reported to my C.S.M. (Cully) who reported to the Major, and through the batman I learnt that the officer received a good ticking off.' ¹⁷

The second is an incident during the Siege of Sevastopol, in 1855,

'One day in March I was one of the sergeants with a party of men that had been sent to Balaclava to bring up supplies in the way of biscuit and pork, or salt junk (salt beef). We had a young officer with us, well mounted, who had but little compassion for poor fellows who were doing their best, trudging through the mud up to their ankles, with a heavy load upon their backs. The party were not going fast enough to suit the whim of our young and inexperienced commander, who called out to the writer:

"Take this man's name, Sergeant, and make a prisoner of him when we get home."

The unfortunate man was doing his best to keep up, and he gave our young officer such a contemptuous look as I shall not forget as long as I live. Throwing his load of biscuit down in the mud, he exclaimed:

“Man indade! Soger indade! I’m only a poor broken-down commissariat mule” ...

The poor fellow was made a prisoner of at once, for insubordination. But when I explained the case to our Colonel he took quite a different view of the matter, forgave the man, and presented him with a pair of good warm socks and a pair of new boots; for the poor fellow had nothing but uppers and no soles for his old ones. And in order to teach our smart young officer how to respect men who were trying to do their duty sentenced him to three extra fatigues to Balaclava - and to walk it, the same as any other man.’¹⁸

The third describes the smoothing out of a difficult relationship between a newly-arrived company commander and his pay sergeant in 1812. The pay sergeant recalls,

‘I soon found the captain to be a disciplinarian of the old school: he required books and returns which would have been a load for a horse. But on speaking to the Adjutant, he reasoned him out of these notions.’¹⁹

The ubiquitous Corporal Todd also provides indirect evidence of the existence of this sort of channel for communications even further back in time. Employed against his will in 1761 as his battalion’s Pioneer Corporal (an arduous and dangerous task that took him away from his *friends* in his company), he was confined unjustly by the Quartermaster in October of that year for allegedly failing to ensure that the officers’ privy was properly screened. His pioneer section came to him and offered to go in a body straight to the Commanding Officer or the Major to set the record straight, but Todd forbade them, hoping that this incident will lead to his sacking as Pioneer Corporal and a subsequent return to his company.²⁰

The identification of similar examples of continuity would enable us to identify long-enduring elements in the British Army’s organisational culture. This information would not only provide longitudinal links between any series of time-specific models that were produced, but they would also be able to inform those who are planning change in the modern British Army. In essence, if particular elements in the *social structures* that inform the lives of soldiers have lasted for a long time then we should be very cautious indeed in planning to introduce change that would significantly alter them.

Investigation of Paradoxes

The model can also assist in addressing areas where historians disagree, or where the apparent facts present paradoxes. Two examples of such areas from the eighteenth century will be now be explored, using, respectively, the top level only of the model and the typology of informal relationships.

The first is a disagreement between Frey and Guy concerning the cohesion of infantry units in the eighteenth century, as identified by Brumwell²¹. For Frey, Regimental pride and tradition served to produce a ‘brotherhood of men’²², whilst for Guy this is a ‘wistful characterization’, particularly in view of the poor quality of the soldiers and the constant recourse to drafting large numbers of men between regiments when the need arose to bring a battalion up to strength for operations²³.

In an attempt to reconcile these views, Brumwell points out that the situation was probably not quite as black as Guy paints,

‘Whilst it is impossible to deny the prevalence of drafting in the British Army of the eighteenth century, it is also necessary to remember that for every soldier who found himself transferred from one unit to another in bewildering succession, there were others who spent all or most of their military career in a single regiment. This was particularly true of those battalions which possessed sufficient seniority in the line to avoid disbandment at the close of hostilities. In contrast to such ‘young’ corps as Bagshawe’s own 93rd Foot, which was little more than a feeder unit for other regiments, these were unlikely to be drafted wholesale with the coming of peace. Even where drafting did occur, the men selected were often those who had been received as drafts from other units, so leaving a rump of veterans who spent their entire service - from enlistment to death or discharge - in the same regiment.’²⁴

thus echoing Odintz’s view, expressed separately from this debate,

‘The practice of freely drafting private soldiers from one regiment to another prevented the regimental orientation of the ranker from becoming too extreme, though soldiers were often adept at transferring their loyalties from one corps to another. Similarly, each regiment contained a number of officers who developed no particular attachment to that corps and who were willing to transfer frequently in search of promotion. However, there were usually enough long-term members of the regiment, particularly among the officers, to ensure the maintenance of a collective identity.’²⁵

Although Brumwell tries to offer us a middle way, and although Odintz's study supports him, we can do even better to reconcile the extremes represented by Frey and Guy by using the top level of the model. If we look for potential sources of unit cohesion from all four structures, then we can see that there are several other factors apart from Regimental pride and tradition that might have enhanced cohesion in units, even in the turbulent circumstances highlighted by Guy. Such factors might be,

Formal Command Structure

- Fair and firm exercise of discipline, using all parts of the chain of command, over newcomers and long-term members alike.

Informal Structure

- Encouragement to form appropriate informal relationships, so that peers welcomed newcomers, and so that superiors and subordinates exercised *association* and *informal access* as widely as possible with them.
- Firm and consistent application of the distinction between *legitimate* and *illegitimate secondary adjustments* by those in authority.

Loyalty/Identity Structure

- Encouragement of newcomers to identify with, and embrace membership of, their new company and their new Regiment, in the expectation that those newcomers would be familiar with the existence and nature of an adaptable *loyalty/identity structure*.

Functional Structure

- The carrying out of meaningful, soldierly, group tasks at company and battalion level.

These considerations would lead us to a better understanding of the nature of the problem that Frey and Guy attempt to address. We may question both the inevitability of the fragmenting effects noted by Guy and the confident expectation by Frey of bonding through regimental factors. We should search instead for a much wider range of variable factors, guided by the model, and thus understand that they will give rise to different degrees of cohesion or disunity in particular cases.

The second paradox appears in the paper by Gilbert on 'Law and Honour Among Eighteenth-Century British Army Officers' which we looked at in Chapter Five (page 250). In this paper Gilbert tells us that cross-rank informal relationships between officers and men were not tolerated in the eighteenth century, drawing his evidence from a set of three Courts Martial in which officers are accused of familiarity with the rank and file. Gilbert concludes that these cases indicate 'how great the gap between officers and men really was in the eighteenth-century army'²⁶. However, we have seen from first hand accounts by both officers and soldiers that warm informal relationships between officers and other ranks, crossing this 'great gap', were indeed a feature of regimental life in the eighteenth century.

The first two Courts Martial support Gilbert's deduction about the gulf between officers and common soldiers fully. The first, in 1761, concerned three officers who failed to get up from dinner and leave when they discovered that one of their female guests had brought a common soldier with her, albeit dressed as a gentleman. Their defence was that they did not treat him like a gentleman²⁷. This defence appears to show that the protagonists knew that they were in the wrong. Their only justification for themselves was that they behaved as if the individual had no status, but the fact remains that, in remaining at the table they were following the conventions of *friendship*, which would have not been an appropriate relationship with a common soldier. They did not obey the conventions of the time.

In the second, in 1762, an officer was found seated with common soldiers in a punch house and was accused of drinking with common soldiers. His defence was that he had simply sat down for moment to remove something from his shoe²⁸. This defence is clearly an attempt to distance himself from the soldiers concerned and to deny any informal interaction between them. This, too, therefore supports Gilbert's thesis.

The third Court Martial, however, presents a different picture. In 1760, Ensign Hill was accused of 'drinking and lying with the private men', following two incidents in an inn²⁹. In the first, he was seen drinking with the men, and in the second he was known to have visited a private room at night which was occupied by a corporal. His defence to the first charge was that, although he had sat with the men, he ensured that they 'continued to preserve that respect which is due to an officer and look'd upon and behaved to me as such during the whole time of my being with them'³⁰. His defence to the second charge was that he had entered the corporal's room only to ask him to help him off with his boots, in the absence of the waiters and hostlers who had gone to bed. Gilbert observes that Hill would not have defended himself in this way unless he felt that such defence had a chance of success, and notes with some apparent puzzlement that,

'... while it was considered dishonourable to consort with private soldiers, it was not always clear what this meant in practice. Under what circumstances could an officer sit down with common soldiers? Could he drink with them if they treated him with respect?'³¹

The typology of informal relationships provides the key to the logic of Hill's defence, and thus an answer to Gilbert's questions. Hill's defence to the first charge can be seen as an attempt to establish that the informal interaction was in the form of *association*, with all concerned preserving the superiority and inferiority and client/patron elements that are a feature of that relationship. His defence to the second charge was to claim that he was exercising *informal access*, in this case going without special arrangement to a junior person for a necessary favour.

If viewed in the light of the typology of informal relationships, therefore, we may go further than Gilbert was able to. The first two cases amounted to officers behaving as if they were in the peer relationship of *friendship* with common soldiers (eating and drinking

together), while the defence in the third case tried to establish the permissible cross-rank informal relationships of *association* and *informal access*.

Conclusion

Our exploration in this section has shown us that the application of parts of the existing model to the historical domain are likely to improve our ability to analyse first hand historical data.

We may further speculate that considerable additional analytical benefits would arise from the construction of time-specific models of *social structures* in the British Army. We now move from historical to current issues.

SECTION THREE - THE PRESENT

Introduction

This section explores how the model might be applied to areas that are of present concern in the British Army, by a brief examination of its potential to provide insight and guidance in two areas. These are the training of officer cadets and young officers in leadership, and the integration of women into combat arms units. They were selected because leadership training is a subject of perennial concern to the Army, and the integration of women into the combat arms has been of increasing importance over the past fifteen years for both legal/sociological reasons (the increasing preoccupation with 'equal opportunities') and the growing shortage of male recruits³².

The particular virtue of the model which makes it suitable for the examination of such issues is that it provides a valid, logical and neutral analytical framework with which to address military issues that have a centre of gravity at unit level. These virtues make it potentially suitable as a tool with which to address aspects that are either emotive or beset by prejudice, or both. Indeed, this potential has already been recognized by members of the Centre for Human Sciences, Farnborough, insofar as aspects of the model have already been

included in three of their studies for the Ministry of Defence under the Corporate Research Programme³³.

Training of Officer Cadets and Young Officers in Leadership and Management

Introduction

The Army recognizes that there is a significant overlap between the terms ‘leadership’ and ‘management’, and uses them together to encompass the practical skills and theoretical knowledge that are required to handle personnel in associated military tasks and environments³⁴. To this extent, the word ‘leadership’ incorporates a significant element of ‘management’ when it is used alone, and this practice is followed here.

In the Conclusion of his comprehensive review of ‘leadership training’, and its application in training officers in the Army in 1995, Rodley declared that ‘The Army’s approach to leadership training and development is limited’³⁵. Whereas he acknowledged that the foundational instruction in leadership for officer cadets at the Royal Military Academy Sandhurst (RMAS) met its remit effectively, his main concern was with the effectiveness of leadership training thereafter, which he found inadequate. In particular, he questioned the ‘primary mechanism by which leadership is learned ...’ through ‘on-the-job experience and “osmosis” through observation and subsequent emulation of one’s superiors’.³⁶ This section shows how the model can be used to identify and address particular issues raised by Rodley’s observations.

The Current System

The training in leadership and management at Sandhurst has as its core a widely accepted body of literature covering the associated theory. This theoretical core is taught by the academic and military staff of the Academy and combined with specific practical sessions and discussions to meet the needs of young officers. In all major respects it is still the same as that examined by Rodley³⁷, and is not expected to change substantially in the near future.

However, the detailed contents and delivery of the leadership and management training package at Sandhurst are being reviewed and made compatible with the Joint Services Systems Approach to Training³⁸ (SAT), to which we will return later. The changes are expected to come into effect in the final term of 2002.

Although, as Rodley says, this training is capable of establishing a very reasonable theoretical baseline for young officers, there are general difficulties with the subsequent process which he describes as ‘osmosis’ at regimental duty. In particular, as he observes, ‘this approach is not systematic and leaves much to chance’³⁹. Rodley’s findings are supported by a general feeling among officers and NCOs at regimental duty that each newly-arrived officer still has a lot to learn about the realities of leadership and man-management, as the following, typical, quotations from my fieldwork show,

- Interviewer: “What do you dread most in a new young officer from Sandhurst?”

Infantry Senior NCO: “Full of bright ideas from Sandhurst that don’t work.”⁴⁰

*

- Interviewer: “I have heard it said that a young officer at Sandhurst is trained to think that he knows it all when he arrives in the battalion.”

Infantry Private Soldier: “That is a very good statement. Because 90% of the officers within this battalion now wouldn’t listen to a [private soldier] at all, even if he [the officer] was wrong. ... Most of them would go ‘Don’t be stupid. That’s what I get paid so much a day for.’”⁴¹

*

- Interviewer: “Do you find that young officers are properly prepared how to behave to sergeants, corporals, private soldiers?”

Infantry Junior NCO: “The only thing I can say to that really in my experience is that sometimes they’ve been very arrogant when they’ve come from Sandhurst. Not willing to learn from people that are junior from them in rank.”⁴²

*

- [A captain describes how he learned his way round his unit immediately after his arrival from training, six years earlier] ‘by a bit of innate intuition and by seeing other people fail, rather than by what he had been taught at Sandhurst.’⁴³

*

- Royal Armoured Corps Late Entry Captain, “Young officers have difficulties in relaxing at first when they arrive and they have to learn to relate to soldiers.”⁴⁴

*

- Interviewer, to Infantry junior NCO: “Think of the three most recently arrived young officers from Sandhurst that you have had anything serious to do with. Do you think they came prepared?”

“No Sir.”

“What did they have to learn, to be good officers?”

“I think, to be prepared for battalion life.”⁴⁵

There is a spread of eight years between these quotations, indicating that the difficulties in the situation of a young officer have changed little over that period. It is, in effect, a running sore at regimental duty.

This weakness in the current leadership and management training system has been formally recognized by a recent review of officers’ careers⁴⁶, and as a consequence a two week leadership and management training package for young officers in their first tour at regimental duty has been developed. This, *The Junior Officer Leadership Programme*⁴⁷, will be delivered by Army Education Centres to officers who have served in their units for at least a year but less than two years. It largely repeats the material in which the officers were instructed at Sandhurst, and encourages them to set it against their experience at regimental duty.⁴⁸

One of the significant sources of this weakness has been the fact that the officer cadets do not have any contact with soldiers at regimental duty while they are at Sandhurst. The only soldiers that they see are highly unrepresentative of the ones whom they will encounter once they reach their units: there are virtually no private soldiers at Sandhurst, the NCO and warrant officer instructors are specially selected, and there are no junior officers⁴⁹.

Although, therefore, the theoretical foundation is sound, the officer cadets are given no means to connect it to the realities of life at regimental duty. *The Junior Officer Leadership Programme* may or may not help them to make the connection but in any case they will not experience it until their second year at regimental duty.

Using the Model to Search for Improvements

If this situation is to be improved, the instruction at Sandhurst should attempt to provide a bridge between leadership theory and the practicalities of life in a unit. At the least, this should increase the likelihood of effective ‘osmosis’ subsequently, and at best give the young officer a clear and direct awareness of what this ‘osmosis’ is expected indirectly to achieve. The model allows us to build an instructional module that could be used to achieve this purpose. The rest of this subsection shows how that module might be built.

At the highest level of the new draft Sandhurst leadership and management training package, following the usages of the Joint Services Systems Approach to Training (SAT)⁵⁰, is the ‘Training Objective’ (TO) which encapsulates the package’s purpose. This reads, ‘TO 8, Demonstrate Leadership and Management’.⁵¹

According to SAT, an array of ‘Enabling Objectives’ (EO) is required, phrased to set out what the trainees can be expected to do at the end of the instruction. Appropriate phrasing of an EO to overcome the problem brought out by Rodley and reflected in my interviewees would be ‘To understand the practical realities of life in a military unit’.

EOs should be followed by a more detailed set of ‘teaching points’ (TP) providing a sequenced framework for the development of individual lessons. As the central purpose of the model is to represent the background to, and framework for, daily life in a military unit, we may expect it to be of considerable use in generating the teaching points for the suggested enabling objective, as we will now see.

At the top level, the four *social structures* provide four headings to consider when producing teaching points, each heading indicating a separate domain in which a successful leader must be able to exercise his or her leadership and management. The more detailed information at lower levels in the model can be used to provide more focused information for

the young officer to help him or her to understand the nature of life in a unit and what constitutes successful leadership. For instance, at the top level, the model indicates that it is important that the leader should be able to function successfully in all four structures: if he or she were only capable of functioning as a leader in, say, three out of the four then they would fail to lead successfully when the fourth is the *operating structure*. The more focused detail below the top level would provide direct information to generate personal goals in such areas as carrying out 'soldierly' tasks, using the appropriate terms of address in different circumstances, and understanding the importance of the different levels of *loyalty/identity segment*.

To illustrate these points the four *social structures* will be used, taking the typical case of a young male second lieutenant, to produce short summaries of standards that he would have to achieve to be a successful leader,

Formal Command Structure

- He should be able to issue orders clearly and authoritatively, to listen to reports from below, and to understand and obey orders from above. His appearance and behaviour should be consistent with the disciplinary customs of the unit. He should understand that each soldier has a unique place in the unit with which that soldier identifies.

Informal Structure

- He should know the qualitative differences between informal relationships, and build appropriate ones. Examples would be *association* with the senior NCOs in his sub unit (and especially any under his command) *informal access* with his private soldiers, *friendship* with his follow-subalterns, and *association* or *informal access* with his sub unit commander. He should be prepared to allow relationships of *association* to develop with his junior NCOs and private soldiers over time.

- On the other hand, he should not attempt to achieve, or encourage the development of, inappropriate relationships such as *friendship* with his NCOs or privates.
- He should be aware of, and observe, appropriate terms of address for the various relationships, but have his personal strategy ready for the *special informal circumstances* when the conventions of terms of address may be suspended.

Loyalty/Identity Structure

- He should take an active part in supporting the *loyalty/identity segment* that he commands, both during events where pride and prestige are at stake (such as competitions) and during celebrations of his segment's identity (such as parties).
- Because of the *loyalty/identity structure's* flexibility, he should also take an active part in supporting the segments above the one he commands, such as the sub unit and the unit, and he should acknowledge his soldiers' membership of the segments below the one which he commands, and encourage them to exercise that membership.
- He should also learn the details of his Regiment's, unit's, and sub unit's history and traditions and be seen to identify with them.
- He should support all sporting occasions that any of his *loyalty/identity segments* partake in, and should participate in as many as he can.

Functional Structure

- He should perform his own function well, showing both personal (soldierly) skills, special-to-arm skills, and the ability to exercise professional military command effectively. He should show that he recognises good performance and congratulate those who show it, and give encouragement to those who fall short but in his judgement are trying to perform well.

- He should show concern for the maintenance and improvement of individual and collective training standards.

Such short summaries give us detailed practical goals that leadership and management training for young officers should be seeking to achieve, and from which it would be possible for a course designer at Sandhurst to create the necessary teaching module. This is demonstrated in greater detail Appendix F where I have constructed such a module.

At a subsequent stage, probably at the special-to-arm young officers' course that is the usual stage between Sandhurst training and deployment to a unit, a further, more focused degree of detail could be provided. In particular, this new material ought to cover the particular areas of the *loyalty/identity structure* and the *functional structure* that are pertinent to the special nature of the units that they are joining.

This analysis and the training module in Appendix F were put to the SO2 Leadership and the Colonel Training at Sandhurst in February 2002. Their immediate reaction was that it had the potential to provide an important link that had previously been missing, and they have since adopted the model as a tool in their restructuring of the leadership syllabus. A letter explaining the situation is in Appendix G.

Integration of Women into the Combat Arms of the British Army

Introduction

The purpose of this subsection is to examine the potential of the model to help us to address the integration of women into the combat arms units of the British Army.

Integration of women into the regular logistic units of the British Army is well under way. As at 1 January 2002, there were 1,648 adult trained women in the Royal Logistic Corps (RLC) (11.2% of the strength of the RLC), 218 (2.4%) in the Royal Electrical and Mechanical Engineers, and 1,326 (29.7%) in the Adjutant General's Corps (Staff and Personnel Services), for example. The Royal Army Medical Corps is 22.2% female⁵². However, the research for this thesis did not include logistic units, so at this stage we cannot

be certain if the model is entirely appropriate to them. In this subsection we will therefore concentrate entirely on regular combat arms units.

The integration of women into armed forces is a much debated subject, especially in the USA⁵³, with the combat arms a particular battleground because of the tradition and assumptions therein of ‘male’ attributes centred on aggression and violence⁵⁴. An overview of the literature indicates that this area is a fraught and complex one, encompassing many strands of argument. Some, like Bracken⁵⁵, stress the political pressure for the entry of women into all parts of the British Army against what could be seen as reactionary defensive measures on its part. Some, such as Gemmell⁵⁶, point out that the medical stress on women who are striving to meet a gender-free physical standard is greater than that on men, and express concern over the consequent failure of the British Army in exercising its duty of care towards its women. On the other hand, others, exemplified by Kennedy-Pipe, seek to show that the physical nastiness of war is declining in the era of long-range stand-off engagements and so women’s physical limitations are becoming irrelevant⁵⁷. Some adduce arguments that women should be welcomed into all parts of the Army because they bring special gender-specific capabilities whilst physical strength is not such a requirement as it used to be⁵⁸. Yet others are concerned at what they see as negative consequences for unit and small group bonding that are likely to arise from the mixing of the sexes, as Simons does⁵⁹. These arguments are admirably summed up in Dandeker’s entry in the *Oxford Companion to Military History*⁶⁰, which concludes that,

‘In the UK, it is likely that the remaining rules excluding them from the front-line positions will be removed, although whether this would, in fact, lead to more than a small minority of women with the inclination and ability to meet the standards demanded of infantry roles remains doubtful. Controversial issues connected with the training and working relations of gender-integrated units will remain.’

Kennedy-Pipe provides a complementary review, which revisits many of these arguments but adds a useful summary of the political dimension to this debate,

‘... the gendered nature of the military establishment is arguably significant for the place of women within society generally. The feminist argument was and is a simple one: men have ‘captured’ the state, so women must reclaim it. Equality for women

can be achieved first by gaining equal opportunities in education, in social institutions and in the workplace and then through the gradual achievement of parity of representation in the central offices of the state: within the legislature, the judiciary and, of course the military. Here, as Jill Steans has pointed out, the armed services and military institutions are regarded as especially important to women trying to achieve high office. To paraphrase Steans, the military plays a special role in the ideological structure of patriarchy because the notion of combat plays 'such a central role in the construction of manhood and in the construction of the social order'.⁶¹

The area is clouded by two further considerations. On the one hand, of the seven 'combat arms', only three currently do not in fact have women members. These are the infantry, Household Cavalry and the Royal Armoured Corps, and even in the units of these arms it is possible for women to be present in small numbers as attached personnel (clerks, for example, or chefs or technicians). Of the others, in conventional war, the Royal Artillery are organised to deploy women to the front line as members of forward observation parties, the Royal Engineers intend to deploy women on combat and assault engineering tasks that bring them well up into the contact zone, and female Army Air Corps air crew are expected to fly over territory held by the enemy. Even in the Royal Signals, which in theory does not have a role at the very front, mixed-sex detachments are expected to set up and maintain communications in areas where direct enemy interference can be expected. If it is expressed in absolutes, the argument is therefore not so much about 'women in the front line' as 'women members of infantry and armoured Regiments'.

On the other hand, the relative number of women in many of these 'combat' situations remains small. There are very few women in forward observation parties, similarly few Royal Engineers (because currently only officers may be women and they do not form a large proportion of the Royal Engineer officer corps)⁶², and there are few Army helicopter air crew who are women.⁶³

It should also be remembered that (as at November 2002) there are no women in those areas of the Army where physical strength and endurance are major qualifying factors, the Commando Brigade, the Parachute units, and the Special Air Service, although one woman has now passed Commando Course and has been posted to, but not yet joined, 3 Commando Brigade Logistic Regiment.⁶⁴

Use of the Model

The purpose of this subsection is to explore how a version of the model may be used to illuminate our understanding of the practicalities of life in mixed-sex combat arms units, to highlight particular areas of difficulty and suggest practical means to overcome those difficulties. The issue is mapped on pages 337 to 345 using the model and potentially successful ways forward are derived from the model on pages 346 to 349. It is stressed, however, that although what follows appears to be a useful way forward, and reflects promising strands that emerged in researching the main thrust of this thesis, further work would be needed to confirm the full range of its usefulness, and to gauge the significance of any changes since the main bulk of the interviews was conducted.

In Chapter Three, it was made clear that the model was developed in units that were virtually all male (see Chapter Three, page 76). A few female soldiers were interviewed however, and some male soldiers with experience in mixed units, so enough data has been gathered to achieve provisional position on this subject, as a starting point for more targeted research in the future.

The first step is to define the terms ‘sex’ and ‘gender’, which, in line with general social science practice⁶⁵ are used in this subsection as precise terms:

‘Sex’ is a biological category used to differentiate male and female. It is absolute.

‘Gender’ is a cultural category, encapsulating social attitudes towards the sexes and customary assumptions about them. It is variable between cultures, and can change with time within a single culture.

The next step is to examine what changes are likely to be needed to the ‘virtually all-male’ model to account for the mixing of sexes. The principal adjustment that seems to be required is to the suite of informal relationships, which currently have no element in them to describe or encapsulate sexual attraction. To that end, three additional relationships were identified.

The first is a cross-sex relationship that is asymmetrical in rank where the senior party assumes either a protective or dominating role towards the other. For example, as one male warrant officer put it,

“There’s a lot of women in the Army that can play the soft option. They can find a senior rank, a junior rank or whatever, that’s a bit soft on them and they’ll [exploit them].”⁶⁶

This is not modelled as a relationship which either party expect will lead to sexual intercourse. I have called it *parent/child*, noting that, in most cases, the initiative lies with the senior party, who can continue to dominate the life of the junior even if he or she rejects the relationship. Whilst something similar to *parent/child* can be found in a single sex environment, where a senior person favours or oppresses a junior, the cross-sex element seems to give the relationship considerably more power and influence in the lives of soldiers, and it seems to occur more often in a mixed-sex environment. It therefore needs to be considered as a separate category for mixed-sex units.

The second and third relationships are logical outcomes of sexual attraction, where sexual intercourse is considered by at least one of the parties as a reasonable possibility.

They are:

- A cross-sex relationship based on sexual attraction, referred to here as *mutual desire*.

- A cross-sex relationship that is one-sided, which we may call *unreciprocated desire*.

If we now apply the model, as adjusted, to soldiers’ lives in a mixed-sex unit, we may predict with confidence that a necessary condition for the successful integration of women into the unit must be their integration into all four of the *social structures*. As in our consideration of leadership above, if integration is only partial, say into three out of the structures instead of four, then problems will arise when the fourth structure is the *operating structure*. We will now examine each of the *social structures* in turn.

Formal Command Structure

It would be hard to produce a convincing biological argument why women cannot be integrated into the *formal command structure*. There seem to be no such factors that might preclude a woman either taking or giving orders, assuming responsibility, working under or enforcing discipline, or from possessing a unique place in a unit's organisation. There are, however, some cultural, gender-based, factors that might make the position of a woman in the chain of command difficult. These include:

- Unwillingness by men to be put in the wrong (by the discipline system) in front of women. The presence of women seems to amplify the disgrace felt by the individual male soldier when he is being told off by a superior. As a female major put it, "I don't think men like being disciplined by women. As a gut reaction ... They're not used to women being in authority. It is not a social standard."⁶⁷ This aspect may well fade in an increasingly gender-equal society, but in any case it need not be an obstacle to gender-free soldiering: used sensitively it could be used by women to enhance their power of discipline as it would provide them with an extra dimension of command.

- A second factor is dress. Women are treated in many arenas of British culture as legitimate subjects for sexual desire. Television, newspapers and films regularly portray women's bodies as visually exciting objects for male entertainment. If the military are to promote gender-free attitudes in the *formal command structure* it is therefore important that female military uniform should not reflect this gender attitude. The model therefore suggests that neither those who give orders nor those to whom they are given should be dressed in a way that is particularly visually appealing to the opposite sex. Interestingly, these observations, which were generated entirely through the model, were subsequently found to echo some of the issues in Hillman's paper on the clothing of women in US military academies.⁶⁸

Loyalty/Identity Structure

There seems to be no reason why women should be incapable of full integration into the *loyalty/identity structure*. In the same way that people of all ranks can belong equally to the relevant groups so can people of both sexes. All members of the unit, regardless of sex, should therefore be encouraged to support all the *loyalty/identity segments* to which they belong, and exercise membership of them. In itself, this is likely to be an organisationally beneficial bonding process.

Functional Structure

It will be recalled that one of the major aspects of the *functional structure* is the carrying out by soldiers of tasks that are seen as 'soldierly' according to shared mental models. Whilst women may perfectly well become members of functional groups and carry out many military tasks, there are biological reasons why certain tasks are beyond the physical capabilities of all but a very few of them. For example, the bringing into action of an AS 90 field gun may be accomplished by a group of soldiers regardless of sex because of the mechanical assistance provided by the on-board hydraulic systems, but the setting up and handling of the ammunition for the gun requires physical strength and stamina beyond most women. A gun may fire well over 100 shells weighing over 90 lbs. in a battlefield day, and each one has to be lifted manually and carried over several metres.

This important point is also supported by recent research which has indicated that while properly 'conditioned' [mentally and physically prepared] women can do as well as many men at physically demanding tasks, 'women will work closer to their maximum physical capacity for all components of physical activity, and therefore will fatigue much faster than men'⁶⁹. This probably accounts for the greater proportion of women than men who are routinely temporarily medically downgraded due to medical problems: 6% of male officers compared to 10.5% of female officers and 10.4% of male non-commissioned personnel compared to 15.8% of non-commissioned women as at 1 January 2002⁷⁰. This figure

excludes female personnel downgraded because of pregnancy (a further 3.1% of officers and 5.8% of other ranks).

The importance of soldierly credibility in the *functional structure* was brought out in an interview with an infantry Junior NCO towards the end of the research period. He had explained that there were several women from the Adjutant General's Corps in the battalion, mainly clerks and chefs. Only two of them had any credibility in his eyes as soldiers, and one in particular was a

“...great girl. The thing is, she's been on the Spencer trophy [a physically taxing competition for the Infantry]. Now, she doesn't look like a bloke, she acts a little bit like a bloke, she likes rugby, she's into, like, physical sports and that. She's dinky - but she done the forty-two miles, done all the stands, done the river crossing, everything,... excellent. The blokes really respect her for it.”

On the other hand,

“the rest of the women don't [do the physical stuff]. Bad. Because they seem to get this sick chit thing. Just going down the med centre and the doctor covering their bum, puts the umbrella up and gives them a chit and passes [the problem] on to someone else. That's wrong.”

Interviewer: “So if they do the business, you think they're good?”

“Yes. Correct Sir.”⁷¹

This is mirrored in the words of a female officer, speaking of how she won the respect of the soldiers who worked with her in a unit headquarters, “By working hard and being good at what you do. Simple as that.”⁷².

Apart from biological factors, there are also gender factors which deserve attention. For example, it is culturally less acceptable in Britain for women to exert and receive violence than for men to do so. This factor may be changing, as is illustrated by the fact that it seems now to be more acceptable than it used to be (say, in the 1950s) for female police officers to risk injury and death. However, there is some way to go before TV pictures of British women in battle will be as acceptable to our society as pictures of men in battle⁷³.

Whatever functional policy is developed, however, care should be taken at all levels to ensure that all involved (women and men, senior and junior) should see it as fair and

reasonable, favouring neither sex. The result of an apparently unfair policy would be the generation within the *functional structure* of barriers that might be transferred to the other structures and thus damage social cohesion within the unit. The following case is a representative illustration,

- '[The informant, male, senior NCO] raised the question of the forthcoming deployment to Northern Ireland. Originally, the women were going on the same basis as the men. Now, however, several of the women originally earmarked are not to go, and so they will displace men from the rear party. They were originally to take part just like the men but that has been changed, and only a very few women are going - and in administrative posts only. Not only that, but they [the women in the rear party] will do courses connected to promotion (Advanced trades courses) that the men can not do because they will be away. This is seen as a bit of an unfair advantage.'⁷⁴

We can see here that the male soldiers' resentment was increased by what they saw as a three-fold unfair advantage: access to family and social life in the home base, early qualification for promotion, and an easier time with normal working hours rather than the intense activity on operations. And all because they were *women*.

Although little specific evidence was collected on this point, it may well be that full integration of women into the *functional structure* will involve more than simple functional integration - 'proving themselves' on an individual basis. There were hints of attitudinal factors in the minds of the men that led them to expect that females would be below standard functionally, and where appropriate these factors will have to be taken account of as well.⁷⁵

Informal Structure

Of the four structures, the *informal structure* seems to be the arena for the greatest challenges to the integration of women into the combat arms, particularly with respect to the nature of informal relationships. While there is nothing to prevent men and women forming relationships of *friendship*, *association*, and *informal access* across the sexes, our culture (particularly as it is expressed in the mass media) puts much more emphasis on the sexual aspects of cross-gender relationships than on the non-sexual ones. As a consequence, where the sexes are mixed in a self-contained social group such as a military unit, sexual tension

seems to be an inevitable consequence. This point is illustrated by the following extract from an interview with a female major,

Interviewer: "I have said that it is not possible for any cross-gender activity to be free of sexual tension. Do you think I am right?"

Major: "My gut feeling would like you not to be right, because I would like to think that you could be very good friends with a male officer and not have to worry about the sexual tension side - that's what I'd like to think. But my experiences over the last fourteen years have probably... if I have to say, I would say that you were right. Unfortunately."⁷⁶

Another female major, who had seen service in the ranks up to sergeant before she was commissioned, said about making informal relationships with male colleagues,

"I think you've got to be careful in forming relationships on a friend basis. I think that the reason why you've got to be careful is some people can misconstrue it and I think that's where the difficulty comes."⁷⁷

and a male view comes from an officer who had commanded a mixed sub unit a few years earlier, speaking of the way he felt when he was in the presence of female soldiers under his command,

"... on the face of it, other people looking at it would think it was a completely sexual-free relationship but my experience would be I don't think I have ever had one - even if it's only 'she's a very pretty girl', or whatever else."⁷⁸

Apart from this generalized sexual tension, the additional, cross gender, informal relationships identified above (*parent/child*, *mutual desire*, and *unreciprocated desire*) are potentially highly dysfunctional within the military social structures. For example:

Parent/Child

- Discipline can be affected by the *parent/child* relationship, in that the 'child' might be treated more leniently than other soldiers, or might be subjected to pressure through harassment or bullying.
- The *functional structure* might be affected by the favouring of the 'child' in the allocation of tasks. For instance, one servicewoman interviewed during the study told of the derogatory nickname given to her fellow (female) soldier of 'Silver Platter' because she was always favoured by the (male) sergeant major. Apparently he took pity on her obvious distress whenever she seemed to be about to be given a difficult or dirty job to do.⁷⁹
- There may also be unwelcome effects in the *informal structure*. The favoured 'child' can experience envy and rejection by his or her fellows which can lead to rifts in the relationships of *friendship*. Rejection can also happen to the bullied or harassed 'child', though in that case it is equally possible that his or her peers might side with the victim against the 'parent'. Should that occur, the relationships of *association* and *informal access* that they might have had with the 'parent' would become damaged.

Mutual Desire

- Sexual attraction is no respecter of persons or rank, and it is only to be expected that soldiers will feel attracted to particular individuals of the opposite sex. Furthermore, sexual attraction is unlikely to be confined by considerations such as rank and organisational structure. However, if *mutual desire* exists between people of widely differing ranks there is a risk that it will seriously interfere with the operation of the systems of authority and discipline in the *formal command structure*.

Similarly, just as *parent/child* relationships can affect the *functional structure* by creating an easy forum for favouritism, so can relationships of *mutual desire*.

- As we have seen, a great deal of the life of a unit depends on the operation of the *informal structure*, and in particular the informal relationships of *friendship*, *association*, and *informal access*. The introduction of *mutual desire* within the networks built out of those relationships has potentially major consequences. For instance, groups of *friends* can be divided or disrupted by competition for the establishment of such relationships, and *association*, which is in essence a close but asymmetrical relationship, would be turned into an equal partnership if it was replaced by *mutual desire*.

Unreciprocated Desire

- *Unreciprocated desire* has the potential to be highly dysfunctional. If it exists between individuals who would otherwise be in positions of *friendship* if both were males (members of the same Royal Signals detachment or Royal Artillery gun crew, for example) then the likelihood of there being the mutual trust and cooperation that would normally result is small. Equally, if it exists between people who might otherwise be in a relationship of *association* the benefits of that bond would be lost. In these situations, one could confidently expect the relationships to be cool at best, and savagely divisive at worst.

In summary, as a female major put it succinctly in an interview, “Get men and women together and they are not sensible. And the human factor and the sexual factor will be there”.⁸⁰

Deductions

Having used the model to highlight possible points of difficulty for a mixed-sex combat arms unit, we may now use it to look for guidance as to how successful integration of women into such a unit may be achieved. The model can help us to identify how the advantages provided by the *social structures* might be exploited, and to focus on promising ways to avoid the dangers that we have identified.

Provided that the hierarchy of the unit is aware of the problems caused by letting gender issues intrude into the *formal command structure*, the model suggests that the integration of women into that structure can be achieved simply, and we have seen that the *loyalty/identity structure* presents no obstacle to the integration of women. The *functional structure* contains no absolute barrier to the integration of women (though it must be accepted that some physical tasks in the unit will be beyond most women). The main proviso should be that the unit's policy is carefully balanced to ensure that fair play is seen to be exercised and that unjustified assumptions of poor performance by the women are shown to be false. The major pitfalls appear in the *informal structure*, and the question remains as to how they should be negotiated.

The most fruitful avenue of approach appears to be to examine ways of ensuring that, when they occur, relationships of *parent/child*, *mutual desire*, and *unreciprocated desire* cause the least possible dysfunction in the system of social relations within a unit. It would be sensible therefore for commanders to develop appropriate strategies to manage those situations. The following are illustrations of what such a management strategy might include,

Parent/child. By the logic of the relationship, the dominant protagonist in *parent/child* seems most likely to be the senior one: if he or she (and where the majority of the personnel in the unit is male it is most likely to be a man) resists the formation of the relationship then it can not be formed; if the junior partner resists then the senior one has the option to increase the pressure and to make life difficult for the junior. The occurrence of such relationships could be minimised therefore if commanders at all levels were watchful for them and insisted (through the medium of either the *formal command* or *informal* structures) that the senior party terminate them as soon as they are detected.

Mutual desire. Because it is a relationship involving strong drives and emotions, it is self-evident that *mutual desire* cannot be terminated by firm action by commanders. Other, less direct, means must be sought if it arises between individuals for which it is not organisationally appropriate. The following seem to be promising management strategies,

- Through as many of the *social structures* as possible, making it known that sexual relationships between ranks where the gap is so wide as to preclude *friendship* are formally forbidden. This will not prevent such relationships arising, but it will discourage a proportion of those potentially involved in them, and leave everyone in no doubt that they are inappropriate.

- Minimising the occurrence of sexual relationships between individuals who might otherwise have been in *association* or *informal access*, and minimising the chances of groups of *friends* being broken up by competition for sexual access to fellow members of the group. Because most of these non-sexual informal relationships are usually formed between people who are in the same sub unit, this may be achieved by encouraging all concerned to form relationships of *mutual desire* as far as possible in and beyond the more distant organisational segments: if possible outside the unit and certainly outside the sub unit. In cases where this fails, consideration should be given to moving one of the parties out of the sub unit. Interestingly, such minimizing of the occurrence of sexual relationships within the sub unit may not be as problematical as it first seems, because it appears to have advantages that are felt by those involved. It is significant that, of the small sample of women interviewed who were currently serving at regimental duty (seven), all maintained that both they and their friends were more content if they formed their sexual relationships outside the immediate group, and preferably outside the unit itself. This view was echoed by the majority of women officers

subsequently interviewed at the Royal Military College of Science, one of whom was distinctly forthright, “Never never never do it on your own doorstep, it always ends in tears”.⁸¹

- Encouraging men and women to form appropriate non-sexual relationships (*friendship, association, informal access*). A key factor in this would be the full integration of women into the *loyalty/identity structure*, which provides a socially stable area where all are equally members of the relevant groups regardless of rank and sex. In parallel, it would seem advantageous to integrate male and female accommodation so that informal groups may form more easily and to remove the air of mystery and challenge (important ingredients of ‘separateness’) that inevitably seems to surround ‘female only’ accommodation in the minds of the men.

Unreciprocated Desire. As with *mutual desire*, it cannot be assumed that all members of the unit will have complete control over their emotions. *Unreciprocated desire* is therefore likely to arise from time to time whatever the formal instructions and orders are. Commanders should therefore make it a high priority within the management of their unit to identify when such relationships are arising, and organisationally separate the parties as soon as possible. The model suggests, again, that a separation within the unit across a sub unit boundary would have a reasonable chance of success. Wider separation, perhaps by posting one of the parties to another unit or sending them on an appropriate career course, would also have the same effect.

Finally, the model suggests a further factor which would assist in managing any gender-based difficulties within a unit. If there were a substantial female chain of command in place, containing significant numbers of women senior NCOs and captains, and at least one major, then informal channels of communication would be available to both sexes right through the unit chain of command via the common non-sexual informal relationships. Issues

could then be detected, raised, and dealt with through informal channels that did not cross the sexes. I originally made this prediction in my defence fellowship⁸², and it was encouraging to see it confirmed during an interview five years later with a male officer from a mixed corps, “Your predictions that things would change as those things changed, certainly is borne out by what I have [seen].”⁸³

Other Issues

We have just seen that the model has the capacity to address the integration of women into combat arms units in a neutral and logical way. However, just as in the historical domain, it would be a mistake to use the model in isolation from wider aspects. Whereas in many ways the first of our ‘current issues, leadership training for young officers, is a self-contained one within the Army, the integration of women has wider implications that require a larger perspective.

An obvious example of these wider implications is the attitude of soldiers’ spouses and other long term domestic partners to their living and working with members of the opposite sex, sometimes far away and in a close-knit environment. As one major said, remembering her time as a subaltern in a sub unit which frequently had to work away from barracks,

“...the only really serious hassle I got was from my OC’s [company commander’s] wife, who took a dislike to me.”

Interviewer: “Why?”

Major: “Because as she put it I was spending more time with her husband than she was. And she gave me a phone call one day and told me what she thought and I told her in no uncertain terms that she was wrong.”⁸⁴

The husband or wife of a soldier is not fully part of their spouse’s unit, and is not involved in the military social structures. However, spouses exert considerable influence on servicemen and women in the domestic arena⁸⁵. Their views and attitudes should therefore be considered

in the wider context of equal opportunities policies if any changes or developments are to be generally accepted by soldiers.

A second example, and one that falls well beyond the borders of the model, is the attitude of Allies in any future conflict. The attitudes to gender held by foreign nations to which our soldiers are deployed may be significant. It is possible, for example, for Middle Eastern attitudes to women to affect their employability in international HQs or joint commands.

Assessment

We have seen in this section that the model can be brought to bear on issues of current concern in the British Army and that the results are revealing. In such contexts, use of the model has two significant advantages. First, it provides a logical, neutral, and repeatable analytical framework for use in areas perhaps not generally noted for logic and neutrality when they are debated. Second, given that the model was constructed from social anthropological research within the British Army we can also be confident that the recommendations produced by using it are in tune with its organisational culture and therefore much more likely to be acceptable to its members than any which are not. However, when the model is used in any analysis it is important to look out for wider issues that it does not reach.

Notes to Chapter Six:

¹ Cobbett, W., *The Soldier's Friend; or Considerations on the Late Pretended Augmentation of the Subsistence of the Private Soldiers*, London: 1792, p. 9 (published anonymously), as quoted in Stepler, G., *op. cit.*, p. 60.

² Baynes, J., *op. cit.*, 1987.

³ *Ibid.*, 1987, p. 43.

⁴ *Ibid.*, p. 163.

⁵ *Ibid.*, p. 149.

⁶ *Ibid.*, p. 148.

⁷ *Ibid.*, 1987, p. 253.

⁸ *Ibid.*, p. 102.

⁹ Mawton, M., >A Not a Very Nice Regiment=: Her Majesty's 63rd (The West Suffolk) Regiment of Foot=, *Journal of the Society for Army Historical Research*, **LXXVI**, 1998, pp. 73-87.

¹⁰ *Ibid.*, p. 73, citing Dallas, Lieutenant Colonel G., Unpublished letter dated 14 January 1855.

¹¹ Mawton, M., *op. cit.*, p. 86.

¹² Odintz, M., *op. cit.*, p. 489, citing >Fitzgerald, *Correspondence of Emily*, vol. II, 197, *Lady Sarah Lennox to Duchess of Leinster*, Stoke, Aug. 19, 1776=.

¹³ Odintz, M., *op. cit.*, p. 489, citing >Hughes, *Diary*, p. 141, entry for June, 1785=.

¹⁴ Odintz, M., *op. cit.*, p. 489, citing Hughes, *op. cit.*, p. 156, entry for June [no date given] 1785.

¹⁵ Anon, (>T.S.=) *A Soldier of the Seventy-First: The Journal of a Soldier of the Highland Light Infantry 1806-1815* (Hibbert, C. (ed.)), London: Leo Cooper, 1975.

¹⁶ Reid, S., >Who Was the Soldier of the 71st?=: *Journal of the Society for Army Historical Research*, **78**, 2000, pp. 138-139.

¹⁷ Baynes, J., *op. cit.*, 1987, pp. 176-177.

¹⁸ Gowing, T., *op. cit.*, 75-76.

¹⁹ Morley, S., *op. cit.*, p. 105.

²⁰ Todd, W., *op. cit.*, pp. 208-209.

²¹ Brumwell, S., >Rank and File: A Profile of One of Wolfe=s Regiments=, *Journal of the Society for Army Historical Research*, **79**, Spring 2001, pp. 3 to 24. See also Brumwell, S., *op. cit.* 2002, pp. 112 to 114.

²² Brumwell cites Frey, S., *The British Soldier in America: a Social History of Military Life in the Revolutionary Period* (Austin, 1981), p. 112.

²³ Guy, A., *Colonel Samuel Bagshawe and the Army of George II, 1731-1762.*, London: The Bodley Head for the Army Records Society, 1990., pp. 15-17.

²⁴ Brumwell, S., *op. cit.*, 2001, p. 15.

²⁵ Odintz, M., *op. cit.*, p. 25. Odintz uses as a particular example the case of Roger Lamb who, according to his *Journal of the American War* (Dublin, 1809) served loyally in two units as a NCO, the 9th and the 23rd.

²⁶ Gilbert, A., *op. cit.*, pp. 85-86.

²⁷ *Ibid.*, p. 85, citing W.O. 71/75. Lt Sherwin *et al.* Court Martial, July 1761.

²⁸ Gilbert, A., *op. cit.*, p. 86, citing W.O. 71/75. Lt Rose Court Martial, April 1762.

²⁹ Gilbert, A., *op. cit.*, p. 86, citing W.O. 71/47. Lt Hill Court Martial, September 1760.

³⁰ Gilbert, A., *op. cit.*, p. 86.

³¹ *Ibid.*, p. 86.

³² This shortage was strongly brought out in the MOD=s report on Manning and Recruiting in the Lean Years of the Nineties (MARILYN), MOD, *The Marilyn Report* (D/DM(A)/12/114 M1(A) dated Nov 88), 1988.

³³ These studies are: Proud, A., *Potential Effects of Army Unit Culture on Implementation of DBL*, Defence Evaluation and Research Agency, 1999; Rugg-Gunn, M., McLeod, R., Cunningham, D. and Green, A., *Attitudinal Factors Influencing Military Performance and the Potential for Training Interventions* (DERA/CHS/MID/TR01034/1.0), Defence Evaluation and Research Agency, 2001; and Lister, S. G., Mortlock, M., Mains-Smith, N. and Ellshaw, C., *Challenger 2 Commander Performance* (QINETIQ/CHS/CAP/CR/020187/1.0), QinetiQ, 2002. The first two were published when the Centre for Human Sciences was part of the now defunct Defence Evaluation and Research Agency, and the third after its transition into the newly-created QinetiQ.

³⁴ MOD, >Operational Task Statements, Appendix to Job Analysis Report (DP&RG Report No 2/01)=, *Review of Officer Career Courses (ROCC) Training Needs Analysis*, D/AG/11024/2[DP&RG], dated June 2001, p. C1.

³⁵ Rodley, I., *Leadership Training and Development*, M.Phil, Lancaster University, 1995, p. 189.

³⁶ *Ibid.*, p. 189.

³⁷ MOD, >Notes for Instructors: Leadership Term 2, Notes for Instructors, L30-L58=, *The Commissioning Course*, The Royal Military Academy Sandhurst, February 1993. This document was in use up to May 2002.

³⁸ These requirements are set out in MOD, >The Joint Service Systems Approach to Training (JS SAT) Quality Standard=, *Defence Council Instructions, Joint Service*, No. 85 (1 June 2001). This document sets out a standard which the Ministry of Defence has formally adopted.

³⁹ Rodley, I., *op. cit.* p. 189.

⁴⁰ Fieldnotes, 17 March 1994.

⁴¹ Fieldnotes, 14 January 1994.

⁴² Fieldnotes, 19 March 2002.

⁴³ Fieldnotes, 19 March 2002.

⁴⁴ Fieldnotes, 7 March 2002.

⁴⁵ Fieldnotes, 19 March 2002.

⁴⁶ MOD, *op. cit.* June 2001 (ROCC).

⁴⁷ MOD, *Junior Officer Leadership Programme Student Handbook*, March 2001.

⁴⁸ Fieldnotes, 25 February 2002. Conversation with the SO2 Leadership at Royal Military Academy Sandhurst, 4 March 2002.

⁴⁹ Fieldnotes, 25 February 2002.

⁵⁰ MOD *op. cit.*, 2001 (JS SAT).

⁵¹ RMAS Draft Leadership Scalar, dated March 02.

⁵² These figures are given in MOD, Directorate of Manning (Army), *The Monthly Manning Report (MMR)*, (D/DM(A)82/27 dated 4 February 2002) Annex F.

⁵³ See, for example, Segal, D., R., Wechsler Segal, M. and Booth, B., A Gender and Sexual Orientation Diversity in Modern Military Forces: Cross-National Patterns≡, in Katzenstein, M., and Reppy, J. (eds.), *Beyond Zero Tolerance: Discrimination in Military Culture*, New York: Roman & Littlefield Publishers, Inc., 1999, pp. 225-250, this pp. 228-229.

⁵⁴ This aspect is addressed, for example, in Hockey, J., *op. cit.*, pp. 112-122.

⁵⁵ Bracken, P., >Women in the Army=, in H. Strachan (ed.), *The British Army, Manpower and Society into the Twenty-First Century*, London: Frank Cass, 2001, pp. 105 to 118.

⁵⁶ Gemmell, I., >Injuries Among Female Army Recruits: A Conflict of Legislation=, *Journal of the Royal Society of Medicine*, **2002**, 1998, pp. 23-27.

⁵⁷ Kennedy-Pipe, C., >Women and the Military=, *The Journal of Strategic Studies*, **23**, (December 2000), 2000, pp. 32-50.

⁵⁸ Examples of this genre are few, but include Wechsler Segal, M., >Military Culture and Military Families=, in Katzenstein, M., and Reppy, J. (eds.), *op. cit.*, pp. 251-261., this p. 256 (on women in military forces in general), and for the British Army the film sequence >Torchlight= in the MOD=s annual sequence of equal opportunities instructional videos 1999 *et seq.*

⁵⁹ Simons, A., >Women Can Never ABelong≡ in Combat=, *Orbis*, **44**, 2000, pp. 451-461.

⁶⁰ Dandeker, C., >Women in the Military=, in E. R. Holmes (ed.), *op. cit.*, pp. 999 to 1002.

⁶¹ Kennedy-Pipe, C., *op. cit.*, p. 35, citing Steans, J., *Gender and International Relations: An Introduction*, London: Polity Press, 1998.

⁶² As at February 2002, there were 49 Female Royal Engineer officers and 411 female members of the Royal Artillery (figures from Annex F of Directorate of Manning (Army), *op. cit.* dated 4 February 2002)= . Of these, most of the Royal Engineer officers have employment categories that could lead them sufficiently far forward to be considered to be >in combat=, but only a very small proportion of the female Royal Artillery personnel are employed in forward observation parties.

⁶³ Conversation with Headquarters Directorate of Army Aviation, SO 1G1, 5 March 2002. The figures as at March 2002 were 20 female air crew, 18 officers and two other ranks. Of the 20, nine were capbadged Army Air Corps and eleven were on flying tours from other Regiments and Corps.

⁶⁴ Conversation with MOD, Services Personnel Policy Branch, 15 November 2002.

⁶⁵ See, for example, Giddens, A., and Birdsall, K., *Sociology* (Fourth Edition), Cambridge: Polity Press, 2001, pp. 689 and 698.

⁶⁶ Fieldnotes, 31 March 1994.

⁶⁷ Fieldnotes, 14 July 1998.

⁶⁸ Hillman, E., >Dressed to Kill? The Paradox of Women in Military Uniforms=, in Katzenstein, M., and Reppy, J. (eds.), *op. cit.*, pp. 65-80.

⁶⁹ Greeves, J., >Physical Training of Women in the Military=, *Journal of Defence Science*, **6**, 2001, pp. 228 to 238, this p. 229.

⁷⁰ MOD, Directorate of Manning (Army), *op. cit.* dated 4 February 2002)=, p. 2.

⁷¹ Fieldnotes, 19 March 2002.

⁷² Fieldnotes, 26 June 1998.

⁷³ This point is explored briefly in Dandeker, C., *op. cit.*, p. 1001.

⁷⁴ Fieldnotes, 31 March 1994.

⁷⁵ See, for example, Kümmel=s, recent remarks about conditions in the Bundeswehr (Kümmel G., >Complete Access: Women in the Bundeswehr and Male Ambivalence=, *Armed Forces and Society*, **28**, 2002, pp. 555-573, this p. 563), which is in harmony with Hockey=s earlier (1986) study on the British Army, Hockey, *op. cit.*, p. 34-36, and 115.

⁷⁶ Fieldnotes, 26 June 1998.

⁷⁷ Fieldnotes, 25 June 1998.

⁷⁸ Fieldnotes, 14 January 2000.

⁷⁹ Fieldnotes, 26 April 1994.

⁸⁰ Fieldnotes, 26 June 1998.

⁸¹ *Ibid.*

⁸² Kirke, *op. cit.*, 1994, p. 7-9.

⁸³ Fieldnotes, 14 January 2000.

⁸⁴ Fieldnotes, 26 June 1998.

⁸⁵ See, for example, Wechsler Segal, M., >The Military and the Family as Greedy Institutions=, in Moskos C., and Wood F. (eds.), *op. cit.*, pp. 79 to 97.

CHAPTER SEVEN - CONCLUSIONS AND IMPLICATIONS

Introduction

This short chapter identifies the major conclusions from the work and looks at its implications for the British Army, for Social Anthropology, and for other academic disciplines.

Major Conclusions

The principal conclusion is that the concept of ‘social structures’, identifiably different bodies of ideas, rules and conventions of behaviour, each coherent in itself but only brought into operation in appropriate contexts, has provided the means to construct a lucid and effective model of the collective assumptions and shared expectations - the norms - of members of the regular combat arms units of the current British Army. This model, described in Chapter Three and demonstrated in Chapter Four, provides a means to describe, analyse, and predict the behaviour of soldiers at regimental duty in those units. One of its particular strengths is that it has the capacity to penetrate all the constituent parts of such a unit whilst retaining a view of that unit as an integrated whole. It is novel, mature, and can be put into immediate use within its field.

Being solidly based in fieldwork and drawn up by an insider, the model is in tune with the attitudes and expectations of the people whose behaviour and norms it claims to encapsulate. Its use is therefore likely to be acceptable to them, as anecdotally confirmed throughout the research.

The focus on norms is particularly appropriate for a study of the British Army because norms are an important ingredient of everyday life among soldiers: they are regularly thrown into relief in the light of daily events in units, and are regularly embraced by soldiers as part of their organisational culture. However, the model should not be treated as an ethnography in itself, but rather an ethnographer’s tool for use in examining soldiers’ behaviour in combat arms units. It successfully maps the norms and conventions under which soldiers live, but specific ethnographic enquiry must always examine the interaction with these norms by

individual agents.

Uses of the model and implications for further research

The British Army

The tool provided by the model has the potential to be useful to the British Army in many parts of the personnel policy area, where that policy impacts at unit level. We have already seen in Chapter Six that it can be used with advantage to provide analysis and suggest policy in the fields of leadership training and the integration of women into combat arms units. Indeed, the letters from the SO2 Training at RMAS and from MOD Personnel Services Branch at Appendix G specifically endorse its use in those areas. Moreover, it has the potential to contribute to our understanding of wider equal opportunities issues, as the letter (also at Appendix G) from the Tri Service Equal Opportunities Training Centre (TSEOTC) shows.

It can also provide a means to gain an overall understanding of the British army when time is too short to allow the individual gradually to absorb it. For example, the Royal Army Chaplains Department have used a version of the model to help new Padres understand life at regimental duty, as part of their very brief military training package (see Appendix G). It has also been suggested that the model would assist in the design of the rehabilitation package for soldiers who have failed to embrace Army organisational culture and have had consequent psychiatric illness.¹ Work in all these areas is in progress.

Furthermore, the model is of potential use in helping outsiders understand life in the British Army. This is potentially important for the Army because, as the end of National Service recedes into the past, with the continuing decline in numbers of Service personnel since then, fewer and fewer people have direct or indirect experience of the Armed Forces in general, and the Army in particular. This is particularly marked in the field of journalism², which has potentially serious implications for the general understanding of the Army in the wider British society.

Social Anthropology

This work has contributed new elements to the discipline of Social Anthropology. In the first place, although this thesis is not an ethnography, the description and demonstration of the model in Chapters Three and Four are rich in ethnographic detail and provide a coherent portrait of a significant part of the British Army in the past few years.

We have also seen some small developments in Social Anthropological theory. First is the analytical concept of '*social structures*' as identifiably different bodies of ideas, rules and conventions of behaviour, each coherent in itself but only brought into action in appropriate contexts and dormant in others. Whilst it has some common ground with Goffman's characterisation of 'frames', this concept of *social structures* enters the area of social organisation which he specifically eschews and it leads to different, but complementary, insights. In this area it can be expected to be of more practical use than the concept of a single overarching 'social structure', especially among groups of people where norms are prominent in their lives: where the observer can establish a consistent link between context and behaviour, then the attempt to capture the ingredients of these differences into separate categories - *social structures* - can be of considerable assistance in organising the resulting analysis.

Second is the idea that a model of *social structures* can be visualised as a map of the social terrain within which individuals work out their own practice and develop and exercise their own attitudes and expectations. Such a model can act as a bridge between Durkheimian ideas of the compelling force of 'society' on its members and the more modern theoretical paradigms which stress the primacy of those members' agency and practice. It can thus derive advantages from both sets of ideas and help to ameliorate the tension between them. Like a map, *social structures* provide no more than guidance and information to the members of a social group and the individuals can choose to follow or to reject them in any context or at any time. From the lessons learned during this research, it appears that it is necessary to keep two ideas in mind when using this device: on the one hand, individuals are always free to make their own choice of route, often confirming the accuracy of the map but in some cases making alterations to it (the processes captured by Giddens in the concept of

‘structuration’); on the other hand, some terrain will be so constraining that the vast majority of individuals will choose a very small number of possible routes through it (the constrained choices representing regularities ascribed by Durkheim and others to compelling societal forces).

Third, the differentiation of Goffman’s original idea of ‘secondary adjustments’ into *legitimate* and *illegitimate* has been shown to provide a useful means to capture a particular agent’s perception of a rule-bending or rule-breaking activity. It also can be used as a vehicle to explain how two individuals may fundamentally disagree, sometimes to their great surprise, about the propriety of a particular action.

The fourth contribution is the typology of informal relationships described in Chapter Three, which has been shown to be useful in historical as well as contemporary contexts.

It is interesting that these concepts emerged out of research on a military institution, and we may speculate that the necessity to identify and describe them in this study has something to do with the nature of such institutions. It seems to me that they were a necessary part of my analysis because of the highly structured lives of soldiers at regimental duty in regular combat arms units. This highly structured aspect seems to have its origin in the special environment of military operations which brings with it the necessity for a formal body of rules, a rank structure, an emphasis on military function, and the necessity of belonging. However, whatever its origin, it provides a forum where the regular patterns of daily interaction are clearly observable. It is more than likely that, now they have been articulated, these concepts can be imported to other areas of social anthropological inquiry where such structure is less obvious.

Looking to the future, the tiny body of existing social anthropological research into the British Army can certainly be increased using the approaches developed for this thesis. The model, as it stands, could be used immediately as a tool for ethnographic study of a particular unit. It could also provide an axis of research for the comparative study of life in different regular combat arms units. We could compare, for example, the different approaches to the elements modelled in the *formal command structure* in line and Guards infantry units, and how any differences we find are expressed in the *loyalty/identity structures* of those units. It would also be an interesting exercise to compare the balance of importance placed between

the different *social structures* in different units and in different types of unit, to see if there is any theme that can be traced within discrete organisational areas - the different arms, for example, or the different divisions of infantry.

There is considerable scope for development of parallel models for use in other areas of the British Army, beyond the regular units of the combat arms. An obvious such area is the regular logistic units. Whilst it seems unlikely that they differ radically from the combat arms units that we have been considering, it would probably be necessary to adjust the model to take account of such factors as a greater interaction with civilians in the context of daily work, a much more evenly balanced ratio between the sexes, and the integration of military practices with civilian ones. Furthermore, there is no reason to suppose that a single model would be applicable globally to 'the logistic corps' in the same way as a single general model captures the salient features of soldiers' lives in combat arms units. Indeed, preliminary research in the Army Medical Corps has revealed the likely presence of what may be modelled as a fifth *social structure*, which captures a domain within which doctors interact when they are practising medicine. I have provisionally called this the *professional structure*, defined by the shared experience of clinical training within a speciality and shared expectations of clinical training within other specialities. For example, two anaesthetists who have never met have a shared understanding of anaesthetics and a common experience of training in the speciality which will provide sufficient common ground for mutual understanding and speedy bonding in a medical functional context.³

A further area for social anthropological inquiry is the Territorial Army, where the soldiers' military lives are very likely to be affected by their parallel experiences in civilian life, which implies that the model would have to be expanded to include the civilian dimension.

The theoretical concepts and approach of this study are also of course available for use in other military contexts than the British Army. My preliminary work with the US Air Force, for example, showed that at least the top level of the model and the typology of relationships was appropriate for that arena⁴, and I have received encouraging interest in informal discussions with members of the Canadian military at the Royal Military College of Science between 1998 and 2000 and at a recent (2002) seminar⁵. However, further detailed work is needed to ensure that the applicability of the model is more than superficial, and to

construct a suitable version for the new arenas. My brief visit to a Gurkha unit, for example, showed that the model was useful, but by no means sufficient, to account for the soldiers' behaviour⁶ and other models of organising principles had to be brought forward.

Other Academic Disciplines

Finally, the model has obvious potential to inform research beyond Social Anthropology.

A field which we have already explored in Chapter Five is Military History. We saw there that parts of the current model were highly applicable to the study of the British Army of the past, and there is certainly potential to use it, or a variant of it, as a single unifying framework for making comparisons between eras. This framework would build on the analysis in Chapter Five which has shown us that the top level of the model, the differentiation of *secondary adjustments* into *legitimate* and *illegitimate*, and the typology of informal relationships can be used as they stand to contribute to our understanding of the behaviour of British soldiers at least as far back as the mid eighteenth century. However, this unifying framework would have to be capable of connecting with other issues from the wider British society, beyond the scope of the current model, that impacted on the soldiers' behaviour.

It would also be illuminating to create further, more detailed, time-specific models of the same type to examine in detail the British Army in particular historical contexts. Such models would enable the historian to describe, analyse and explain British soldiers' behaviour in a novel way that is likely to be in harmony with their actual experience, and to track and describe changes in the Army's organisational culture.

Beyond the military context, there is an obvious use for the concept of *social structures* as a model in the field of Organization Theory because this concept was created for the study of a particular organisation. In pursuit of this idea, I carried out tentative research at the Centre for Human Sciences (initially part of the Defence Evaluation and Research Agency and latterly QinetiQ) between mid 2001 and early 2002. I have concluded from these preliminary observations that the modelling of *social structures* would probably help to encapsulate the different behaviours of the members of staff in different contexts, and to identify the existence of hierarchies of influence and power that are not formally established.

This indicates that the concept of separate *social structures* may provide an axis for future research to describe and map the illusive area of what Likert called ‘intervening variables’ forty years ago and for which the search goes on,

‘Much less attention is given, however, to another class of variables [other than productivity and output, which Likert calls ‘end-result variables’] which significantly influence the end results. These variables, seriously neglected in present measurements, reflect the current condition of the internal state of the organization: its loyalty, skills, motivations, and capacity for effective interaction, communication, and decision-making. For easy reference these variables will be called *intervening variables*.’⁷

Conclusion

Whatever the nature of the follow-on research, we can be sure that this thesis contains a portrait of the world in which the soldiers in the regular combat arms units of the British Army are immersed. Although academic words such as *social structures*, *illegitimate secondary adjustments*, or *association* may leave them unimpressed, and although, as one hard-bitten warrant officer told me before he saw the model, “It’s bound to be crap”⁸, all British soldiers who have seen the model and heard me explain it, including this critic, have agreed that it describes their lives. Perhaps the most concise view was expressed by a major who told me that, from his point of view, it was “articulated common sense”.⁹ If this is true, then I take it as a compliment, for that, surely, is what scholarship should be.

Notes to Chapter Seven:

¹ Conversation with Capt M. Kiernan RAMC, Military Training and Rehabilitation Unit, Dutchess of Kent Psychiatric Hospital, Catterick, 20 June 2002.

² Conversation with Professor Christopher Bellamy, former Defence Correspondent of *The Independent*, 4 November 2002.

³ Fieldnotes, 13 June 2001.

⁴ Fieldnotes, 22 June 1994, summarized in Kirke, C., *op. cit.*, 1994, pp 6-2 to 6-4.

⁵ Inter-University Seminar on Armed Forces and Society, Kingston Ontario, 24-26 October 2002.

⁶ Fieldnotes, 21 July 1994, summarized in Kirke *op. cit.*, 1994, pp. 6-4 to 6-8.

⁷ Likert, R., *New Patterns in Management International Student Edition*, New York: McGraw-Hill Company, Inc., 1961, p. 61.

⁸ Fieldnotes, 25 July 1994.

⁹ Fieldnotes, 25 February 2002.

**APPENDIX A: REPRODUCTION OF KIRKE, C., 'A MODEL FOR THE ANALYSIS
OF FIGHTING SPIRIT IN THE BRITISH ARMY'**

Kirke, C., 'A Model for the Analysis of Fighting Spirit in the British Army', in Strachan, H. (ed.) *The British Army, Manpower and Society into the Twenty-First Century*, London: Frank Cass, 2000, pp. 227-241 is attached.

Photocopy of chapter attached in the original

APPENDIX B: TEXT OF WORK IN PRESS

The text of Kirke, C., 'Postmodernism to Structure: An Upstream Journey for the Military Recruit?' (in press), is attached.

From: McConville, T., and Holmes, E. R., (eds.), *Defence Management in Uncertain Times*, London: Frank Cass, 2003, pp 139-155.

POSTMODERNISM TO STRUCTURE: AN UPSTREAM JOURNEY FOR THE MILITARY RECRUIT?

Introduction

It is axiomatic in the British Army that recruits experience 'culture shock' as they make the transition from young civilian to trained soldier, and that they always have done. This chapter is focused at the particular form of this culture shock in the early twenty-first century. The views expressed within it are entirely those of the author and do not reflect official opinion or thought.

As the vast bulk of recruits join the Army in their late teens or early twenties the civilian milieu from which they make their transition to the Army is contemporary British youth culture. Whilst this is not a seamless entity throughout the British Isles, there are some constant, or at least very common, features in British youth culture which have at their core certain ingredients first seen in the late twentieth century intellectual movement that has come to be called 'Postmodernism'. We will first, therefore, describe the postmodernist movement and the resultant elements of British youth culture. Then we will examine the organizational culture of the British Army to assess the gap that recruits have to cross in their transition from one to the other. Finally we will briefly consider the implications for the recruit.

Postmodernism

Like many intellectual movements, Postmodernism arose in reaction against existing trends in

thinking. In this case, the ruling paradigm was that of ‘modernity’, the body of ideas that blossomed in Europe in the eighteenth century but had roots that went back to the Renaissance. Modernity sought to break away from what were seen as the confusions and superstitions of the past and replace them with rationality and objective science.

‘The postulates [in modernity] of the thinking self and the mechanistic universe opened the way for the explosion of knowledge under the banner of what Jurgen Habermas called the “Enlightenment project.” It became the goal of the human intellectual quest to unlock the secrets of the universe in order to master nature for human benefit and create a better world. This quest led to the modernity characteristic of the twentieth century which has sought to bring rational management to life in order to improve human existence through technology (1, p. 4).

Important assumptions of modernity and the Enlightenment project were that knowledge could be only be acquired by reasoned rational and dispassionate inquiry, and that this knowledge gave access to fundamental truths that had an independent and lasting existence.

Postmodernism appeared as an identifiable intellectual phenomenon in western universities in the 1970s, though its roots can be traced back to earlier bodies of thought exemplified by the ‘critical theory’ movement in the 1930s. Although it is by its very nature diffuse and fragmented into a mass of ‘postmodernisms’, its general tenets challenge Enlightenment assumptions, question the existence of fundamental or objective truth, and suggest that no aspect of life is fixed or durable. Instead, human perception is socially conditioned: what are interpreted as ‘truths’ are in fact conditioned by the attitudes and expectations prevalent in the observer’s society. Creative individuals are therefore free from any assumptions rooted in the past and can express themselves in any way that they feel is right. As Harvey puts it,

‘Fiction, fragmentation, collage, and eclecticism, all suffused with a sense of ephemerality and chaos, are, perhaps, the themes that dominate in today’s practices of architecture and urban design. And there is, evidently, much in common here with practices and thinking in many other realms such as art, literature, social theory, psychology, and philosophy.’(2, p. 98).

Sarup amplifies this point,

Among the central features associated with postmodernism in the arts are: the deletion of the boundary between art and everyday life; the collapse of the hierarchical distinction between elite and popular culture; a stylistic eclecticism and the mixing of codes. There is parody, pastiche, irony and playfulness. Many commentators stress that postmodernists espouse a model which emphasises not depth but surface. ... It is also said that in postmodernism there is: a shift of emphasis from content to form or style; a transformation of reality into images; the fragmentation of time into a series of perpetual presents (3, p. 132).

However, these freedoms also bring doubts and uncertainties which go far beyond the creative world of the arts and the intellectuals. If what people see as ‘truth’ is simply a socially conditioned reaction to the way in which they experience the world, then many of the fundamental structures of people’s everyday lives are called into question. Thus Postmodernism has escaped from the world of the intellectuals into popular culture, including that of Britain. We can see its influence in everyday life in a number of ways. In particular, aspects of our culture that provided frameworks and form to the attitudes and expectations of ordinary people before the 1980s have now been replaced with ephemeral free-formed elements that lack enduring structure. We can see this effect, for instance, by observing the now established preference for the use of sound bites and pastiche in broadcasting rather than coherent in-depth analysis, the great importance in politics given to ‘image’ and ‘message’ which concentrate on the immediate and the superficial, and, arguably, the general reduction in the expectation that marriage will involve a lasting exclusive commitment.

Examples of the major contrasts that exist between the Enlightenment and Postmodernism are given in the following table:

Enlightenment	Postmodernism
Structure	Chaos
Constants	Transience
Objective Truth	Experience
System	Syncretism

Method	Inspiration
Certainty	Uncertainty

Table 1: Illustrative contrasts between Enlightenment and Postmodern paradigms

In Britain, youth culture can be seen as representing the current extreme of the penetration of Postmodernism in popular culture. External frameworks and order have been replaced by the primacy of individual experience and self-expression. Rules are at best tolerated and questioned, and are often rejected. Youth music has moved from the limited number of accepted enduring categories of the 1950s and 1960s (such as ‘ballad’, ‘rock and roll’, and ‘jazz’) to a multiplex and fragmented array of changing and in some cases transient categories (‘house’, ‘hard rock’, ‘soft rock’, ‘nu-metal’, ‘heavy metal’, ‘dance’, ‘hip-hop’, ‘techno’, ‘rap’, ‘reggae’, ‘garage’, and so on). When it is performed or broadcast it is frequently combined with visual images that have no particular connection to the music and are presented in an apparently random and unconnected stream. Dancing has no structure at all – or rather, it has the structure of the instant, the context, and the inspiration of the moment. Drugs, the ultimate celebration of experience and illusion over the mundane facts of every-day life, are perceived by many young people as a legitimate form of recreation. Religion, for those who practise it, often follows the New Age patterns of self-realisation through experience rather than worship of a constant, powerful, and loving external entity. Sex is a legitimate form of recreation rather than part of a long-term bonding process. In short, life is lived in the experience of the moment, with the transient structure of the moment and any idea of permanence or overall structure is irrelevant.

These aspects have been brought out clearly by Cray, in *Postmodern Culture and Youth Discipleship*, in which he focuses on the social and cultural forms which shape young people’s lives and expectations. For him, ‘One of the many paradoxes of the postmodern world is that there is a great emphasis on image, appearance and style. “Enjoy the surface” is a piece of postmodern wisdom. ... The postmodern self tries to construct its own continuously changing centre.’ (4, pp. 17 and 18).

This then is the environment which the majority of recruits consider natural and normal when they join the Armed Services. As the research which underpins this chapter was carried out almost exclusively in the British Army, it is to that institution and its organizational culture that we will turn now.

Social Structure

The analysis which follows is based on the concept of 'social structure'. The idea of 'social structure' is in essence a framework for everyday life to which all integrated members of the society or human group in question subscribe. It is expressed in the regularities of the day to day activity of those people where,

'the events which comprise human behaviour exhibit regularities whose forms are mutually interdependent, over and above their interdependence in the personality-behaviour systems of each individual actor.' (5, p. xviii).

Giddens has put it more succinctly as 'some kind of patterning of social behaviour', adding that,

'As ordinarily used in the social sciences, 'structure' tends to be employed with the more enduring aspects of social systems in mind The most important aspects of structure are rules and resources recursively involved in institutions. (6, pp. 16, and 23-24).

For the purposes of this chapter, therefore 'social structure' will be used in the following sense: a body of ideas, rules and conventions of behaviour which governs how groups of people or individuals organize and conduct themselves vis-a-vis each other. Conceptually therefore it therefore provides the indispensable background to, and framework for, daily life.

It is now widely accepted that the concept of 'social structure' provides a static image of a human group, which includes an implicit assumption that individuals automatically subscribe to it. The concept therefore needs to be balanced by a consideration of the dynamics of everyday life: individuals make their own decisions about how to behave. Indeed, in their behaviour, or the processes of everyday life, they reproduce or develop the underlying assumptions of their lives, and

thus by their practice they have an effect on the social structure. This has been captured by Giddens in the term 'structuration', which is,

'best thought of as a useful term designating the process of expression and reproduction of social structure (or structural systems) in the informed behaviour of agents 'who draw upon rules and resources in the diversity of action contexts'. (6, p. 24).

A useful analogy by which social structure may be distinguished from process is that of a map. Social structure provides a cognitive map of the social terrain in which the individual finds himself or herself, and that individual navigates his or her own path through it in the process of living. Such a concept proposes the existence of a common structured body of rules and shared expectations within a cultural group whilst still allowing scope for individuals to act in ways of their own choice, and sometimes even to amend the map. In this sense, the model set out below describes the common map which is available to soldiers: each will find his or her own way through the terrain represented by it.

The Organizational Culture of the British Army

This section briefly examines the new rule-set, the new social map, which the recruit confronts in his or her first few weeks as a soldier. In particular, it presents a summary of a model which seeks to capture the organizational culture of the British Army. This model was first published in 2000 (7) and has since been developed slightly. It has been constructed during a period of one year's full time research under the MOD Defence Fellowship Scheme followed by five years research as a part time PhD candidate with Cranfield University (RMCS). The principle subject for the research was the observed behaviour of soldiers of all ranks from private soldier to lieutenant colonel at regimental duty, and their experiences and attitudes expressed in 119 individual interviews and a small number of focus group sessions.

The main field within which the research was conducted was units of the 'combat arms', that is to say those which can be expected to be involved as formed units in the forward battle area in conventional operations. These units comprise the Household Cavalry, the Royal Armoured Corps,

the Royal Artillery, the Infantry, the Royal Engineers, the Royal Signals, and the Army Air Corps. However, strong indications emerged during the research that the attitudes, expectations, and behaviour encountered in those units are generically similar to those of remainder of the British Army. Certainly for the purposes of this chapter we may consider them representative of the overall organizational culture which the recruit enters when he or she joins any part of it.

Initially, the work was aimed at identifying the ‘social structure’ of life at regimental duty in the Army. However, it soon became clear that no single framework could be developed to capture a body of ideas, rules and conventions of behaviour which matched the observed behaviour of soldiers. Different contexts seemed to demand behaviour that was substantially different to that in other contexts. Attention was therefore given to the identification of the range of possible contexts at regimental duty.

Four different families of contexts were identified, each with appropriate behavioural frameworks. These were identified as four separate but contiguous social structures, which were brought together to form the top level of a model that provides a powerful means to describe, analyze and predict soldiers’ behaviour. This top level is sufficient for the purposes of this chapter, representing as it does a generic insight into the organizational culture of the Army. However, it should be born in mind that investigation of more specific areas of that culture would involve using greater degrees of complexity in the model.

As far as the observed behaviour of the soldiers was concerned, therefore, this model seeks to capture the fact that soldiers’ behaviour differs in different contexts, but these contexts can be described satisfactorily by a minimum of four categories, within each of which the expected patterns of behaviour are broadly similar. We may call these four categories of contexts, four ‘social structures’.

The four social structures

It was found analytically convenient in constructing the model to ascribe specific meanings to certain

terms. Whenever these words are used in this chapter, therefore, they are printed in *italics* and defined on first use.

The four social structures comprise:

1. The *formal command structure*, which is the structure through which a soldier at the bottom receives orders from the person at the top. It is embedded in and expressed by the hierarchy of rank and the formal arrangement of the unit into layer upon layer of organizational elements. It contains the mechanisms for the enforcement of discipline, for the downward issue of orders and instructions and for the upward issue of reports, and it provides the framework for official responsibility.
2. The *informal structure*, which consists in unwritten conventions of behaviour in the absence of formal constraints, including behaviour off-duty and in relaxed duty contexts. An important element in this structure is the web of informal relationships within the unit. Individuals come into personal contact with other people within the unit, of any rank, and establish inter-personal relationships with them. Although it might appear at first sight that the quality and intensity of such relationships are determined by free choice on the part of the individual (because they are informal), the network of a soldier's informal relationships is for the most part constrained by his rank and position in the unit.
3. The *loyalty/identity structure*, which is manifested most obviously in a nesting series of different sized groups which are defined by opposition to and contrast with other groups of equal status in the *formal command structure*. The structure itself, the 'body of ideas, rules and conventions of behaviour', consists in the attitudes, feelings and expectations of soldiers towards these groups and their membership. Thus an infantry soldier would express his identity as a member of his platoon and feel loyalty to it in competition with other platoons of the same company. However, where his company is in competition with other companies, these attitudes and feelings would be transferred to the company, rather than the platoon, and this process is continued up to levels beyond the unit (and down to those

below the platoon).

4. The *functional structure*, which consists in attitudes, feelings and expectations connected with the carrying out of specific tasks and military activities. Where groups are formed to carry out such functions, they might exactly reflect the *formal command structure* (which provides an easy and quick means of creating any group within a unit) or they might be independent of it. For example, an infantry platoon (a basic element in the infantry command structure) tends to carry out military functions on exercise and operations as a formed body. In contrast, a 'rear party' which remains in barracks while the rest of the unit is away (perhaps on leave or on an operational tour of duty) is usually made up of soldiers from all over the unit, brought together into an *ad hoc* grouping.

These four social structures are illustrated in Figure 1.

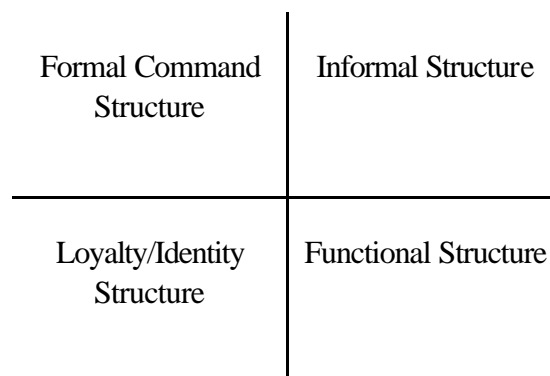

Figure 1: The Four Social Structures

Other elements to the model

The four *social structures* provide the core of the model, but to make the model practicable in use certain qualifying elements need to be added.

First, it is explicit in the model that soldiers only exercise one social structure at a time, though the transition between different social structures may occur rapidly as the context changes. Take, for example, this typical vignette:

Observation: An officer approaches a group of soldiers who are relaxing near their vehicle during a break from maintaining it. The senior member of the group brings it to attention and salutes the officer. The officer returns the salute, and tells them to “carry on”. The group relaxes and a few minutes later the members return to their vehicle maintenance.

Analysis: The soldiers are exercising the *informal structure* as they relax. The approach of the officer necessitates a change to the *formal command structure*. He or she returns them to the *informal structure* by telling them to “carry on”, and they subsequently move to the *functional structure* when they return to work.

The structure of the moment is named in the model the ‘*operating structure*’.

It may be argued that it is unrealistic to insist upon the modelling of one single *operating structure* at any one instant, and it must be accepted as a possible artificiality in the model. However, it remains a useful device in practice. First, it matches a very high proportion of the soldiers’ behaviour observed during the research: as we have just seen, their behaviour does indeed change with the context of the moment. Second, this assumption encourages the observer to look for the moments of transition between structures, even in ambiguous and confusing situations, and thus detect subtle changes in context.

The second qualifying element is a constant factor which exists in all the social structures, which is best called ‘*superiority and inferiority*’. Each social structure has an embedded idea of hierarchy: for the *formal command structure* it is rank; for the *informal structure* there are informal hierarchies of power and prestige (see, (8) for example); for the *functional structure* there is the importance given to the variability between individuals in their military skills and their ability to carry out military tasks; and in the *loyalty/identity structure* each element assumes itself ‘the best’ in some way.

Third, it should be borne in mind that although the four *social structures* in the model have

been described separately, they do not exist in isolation from each other. They inform each other in matters of detail and are intertwined and overlaid in an intricate and complex pattern. The resulting interconnections, which are experienced in the soldiers' daily lives, engender a flexibility and suppleness in the social system that under normal circumstances prevents insurmountable structural barriers arising between individuals or groups within a unit.

Informal relationships

The *informal structure* seemed to be the most chaotic and complex of the four because its rules and conventions of behaviour are generated and reproduced entirely by the mutual consent and cooperation of those operating within it. However, the patterns of informal relationships that emerged during the research were so clear that it was possible to construct the following typology, which represents a sub-model in its own right.

Five identifiably different types of informal relationship were identified, as follows:

1. *Close Friendship*. As defined in the model, '*close friendship*' consists in a durable relationship that transcends the military environment, where there is a large measure of trust and respect between the parties and few barriers to discussion of highly personal matters. In interviews with soldiers of all ranks it was established that, for virtually every one, a useful test to identify *close friendship* would be to determine whether the relationship would survive unchanged if one of the parties was prepared to shed tears in the presence of the other. It is a rare and special relationship. In the words of a warrant officer in an Infantry battalion "I've maybe made only two or three close friends in my career, though I've had plenty of military friends." This rarity is an important feature. It is sufficient to recognize existence of the relationship, but we must also acknowledge that it is sufficiently scarce that it is not a regular feature of regimental life for many individuals.

2. *Friendship*. The term '*friendship*' is used specifically in the model to refer to a less intense relationship which is frequently found to exist between soldiers within the *informal*

structure. It can have all the appearance of *close friendship*, in that individuals constantly seek each other's company, will help each other if they are in trouble, and will be prepared to share almost anything if the need arises, but it falls short of the depth and intensity of the other relationship. Thus, during an interview one soldier said of his particular circle of mates that he would be more than prepared to help any one of them: if a bloke was feeling unhappy then his friends would naturally take him out drinking to cheer him up. However, if a mate wanted to discuss deeply personal matters then he "would not want to know!". Bonds of *friendship* are usually formed within narrow bands of rank. For example, private soldiers may form *friendships* with lance corporals, but a *friendship* with a full corporal may attract disapproval. Similarly, warrant officers may form *friendships* with sergeants that they have known for some time, but there will always be a certain distance in the relationship (particularly if they are in the same sub unit). Senior lieutenants may form *friendships* with captains, but junior second lieutenants are unlikely to do so. Although there are no formally stated regulations which proscribe *friendships* growing up between people of widely diverse rank, such relationships are frowned upon because they are held to be potentially compromising for discipline.

3. *Association*. It is often found that two soldiers separated by rank distance wide enough to exclude *friendship* between them will come into regular contact and will form an informal bond of mutual trust and respect that falls short of *friendship* as defined above, but is nevertheless an important bonding feature. Such a relationship will probably arise, for example, between an Infantry platoon sergeant and his platoon commander, and adjutant and his or her chief clerk or between an Artillery battery sergeant major and his or her battery commander. This relationship was given the name '*association*' in the study.

4. *Informal Access*. It is recognized, though not officially laid down, that each individual has a right to speak informally and without a formal appointment with certain other people who are at a certain degree of structural distance (superiors in his chain of command for instance), even though a link of *association* does not exist between them. Thus a junior officer can expect to be able to have '*informal access*' to his sub-unit commander, as a

private soldier can to his platoon or troop commander. Similarly, any member of a Sergeants' Mess can expect to have opportunities informally to approach the Regimental Sergeant Major.

5. *Nodding Acquaintance*. The term '*nodding acquaintance*' encompasses all the informal relationships which are not encompassed by the other terms. In essence, it is a relationship where the parties know each other by sight, but not necessarily by name, and they acknowledge each other's existence and common participation in the same segment of the *formal command structure*. The relationship may remain as it is, or it may grow into any one of the others listed above.

A diagram illustrating these relationships is at Figure 2. 'Ego' represents an individual who is somewhere in the middle of the rank structure (somewhere between sergeant and captain) and who therefore has informal relationships with those senior and junior to himself or herself.

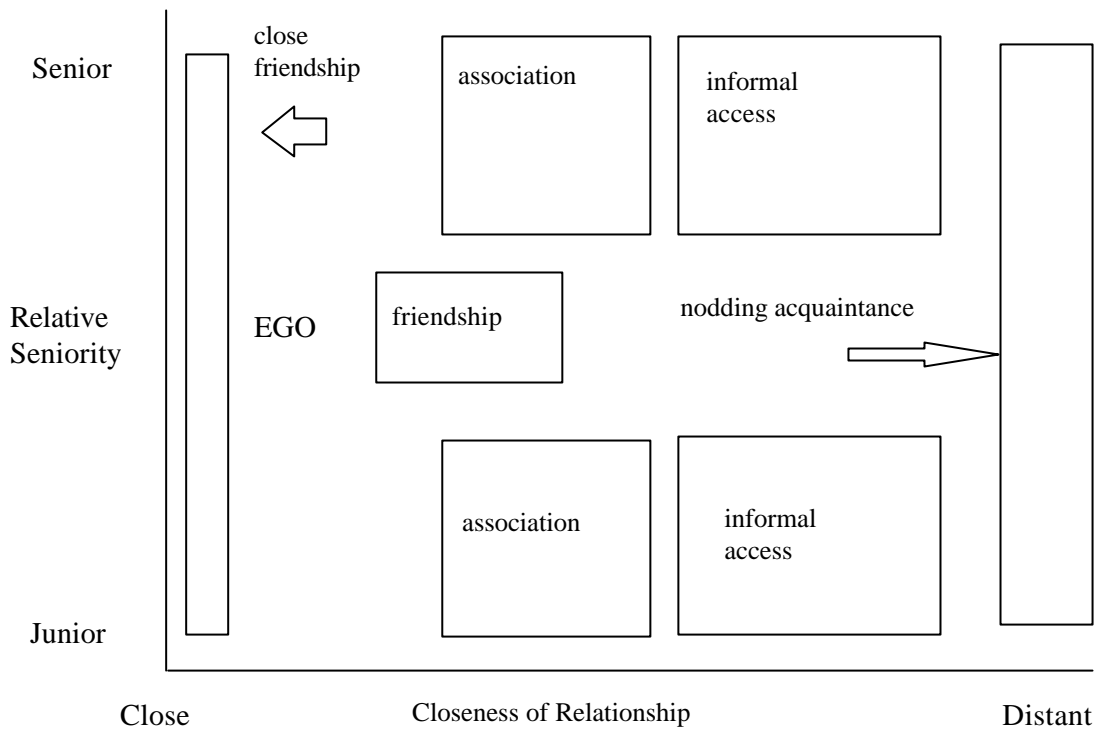

Figure 2: Informal Relationships

In reading this diagram it is important to note that the spaces between the boxes are voids. They show either areas where potential relationships do not exist (as, for example, a rank-based relationship – *association* or *informal access* - between peers) or they are there simply to differentiate between the boxes (as in the gaps between *informal access* and *association*).

In the horizontal axes of the boxes, the diagram allows for different degrees of closeness within each box: the further to the left the stronger. This reflects the fact that, apart from *close friendship*, which is by definition a strong mutual bond, and *nodding acquaintance*, which is essentially weak, a significant variable in any particular case is the strength of the relationship.

The Nature of the Model

During the research it became clear that the organizational culture of the British Army is particularly amenable to analysis by the identification of rule sets, and that these rule sets fell into only

four separate definable categories. There was some concern that this was an artifact of the research, but it was eventually concluded that it actually reflected the fact that the existence of such rule sets was indeed accepted as part of the organizational culture by its participants. It was also observed that there is an inherent tendency for soldiers to want to know what is ‘appropriate’ and what is ‘right’ and to expect such behaviour from their fellow-soldiers. Individually and corporately they find themselves articulating this tendency in the course of their daily lives. Examples are easy to find. The *formal command structure* encompasses unambiguous rank structures, publicly displayed in such things as badges of rank, and written codes of behaviour – *Queen’s Regulations* (9), the *Manual of Military Law* (10), the *Drill Manual* (11), and unit-authored Daily Routine Orders. The *informal structure* includes a significant level of pressure to ‘fit in’ with one’s peers, subordinates and superiors, in an appropriate part of a rank-dependent array of informal relationships as captured in the Figure 2. Functional prowess is an important feature in the *functional structure* and soldiers openly judge each other’s value by their functional attitudes and standards of achievement, and units lay down the way that many operational and peacetime tasks should be carried out in Standing Operating Procedures. The *loyalty/identity structure* appears clearly delineated in the organizational structure of the unit and, above the unit, in distinctions of dress and in unique unit customs and artifacts, and the soldiers articulate loyalty/identity values in their actions and conversation.

Although model was derived entirely from participant observation in the British Army and from interviews with soldiers, as the investigation evolved, it was found to have something in common with other concepts in social science. In the first place, the rules sets identified had something in common with Giddens’ use of Goffman’s concept of ‘frames’,

‘Frames are clusters of rules which help to constitute and regulate activities, defining them as activities of a certain sort and as subject to a given range of sanctions. Whenever individuals come together in a specific context they confront (but, in the vast majority of circumstances, answer without any difficulty whatsoever) the question, ‘What is going on here?’[...] ‘What is going on?’ is unlikely to admit of a simple answer because in all social situations there may be many things ‘going on’ simultaneously. But participants in interaction address this question characteristically on the level of practice, gearing their conduct to that of others. ... Framing as constitutive of, and constricted by, encounters ‘makes sense’ of the activities in which participants engage, both for themselves and for others.’(6, p. 87).

Secondly, the idea of a limited number of such rule sets that interacted in a complex system had common ground with Geertz's concept of 'planes of social organization' in Bali. These 'planes' consisted in a set of seven interacting and intersecting organizational components which between them could be used to account for form and variation in Balinese village social life (12).

Whilst the model's construction and application to the British Army are novel, therefore, it remains within the broad main stream of social scientific thought.

Implications for the Recruit

It will by now be fully apparent that the organizational culture of the British Army is entirely alien to the youth culture described earlier. Where this youth culture lacks any idea of solid structure, contains an assumption that all aspects are ephemeral, and values feelings and experience over external standards, British Army organizational culture is highly structured, based on clear shared rules (both written and unwritten), and contains a constant assumption of hierarchy. In essence, where youth culture is postmodern, British Army organizational structure is anything but.

This, then, is a key element of the 'culture shock' experienced by recruits to the British Army. They have to make a considerable cultural leap, greater than their forebears who came from the more structured youth culture of the past (4, pp. 3-4) and this leap concerns their basic expectations of life and their deeply held assumptions and attitudes. To make matters more difficult for them, they have to do this in an environment, the Army Training Regiment, which is controlled by staff who tend to be highly socialised into the culture that the recruits are trying to join.

Currently, no allowance appears to be made for the difficulties which many recruits must experience in making this cultural transition, and it is entirely possible that a proportion of the numbers currently lost during recruit training are lost primarily because of it. It would seem sensible therefore to consider incorporating this factor in the structure of the recruit training programme. Instead of demanding that individuals leap directly from their familiar cultural milieu into the alien

culture of the Army, there may be considerable benefit in deliberately creating a bridge between the two and helping them to cross it in the early weeks of their training.

No quick answer can be offered here as to how such a bridge might be constructed. Its design would be a matter for future work, but however it is done, it will be important for the designer to have a good appreciation of both contemporary youth culture and Army organizational culture, the two ends of the bridge. It is hoped that this chapter has contributed to the process.

References:

1. Grenz S. *A Primer on Postmodernism*. Cambridge: William B. Erdmans Publishing Company, 1996.
2. Harvey D. *The Condition of Postmodernity: An Enquiry into the Origins of Cultural Change*. Oxford: Basil Blackwell, 1980.
3. Sarup M. *An Introductory Guide to Post-structuralism and Postmodernism (Second Edition)*. London: Harvester Wheatsheaf, 1993.
4. Cray, G. *Postmodern Culture and Youth Discipleship: Commitment or Looking Cool?* Cambridge: Grove Book Limited, 1998.
5. Gluckman M., and Eggan, F. "Introduction", in Banton M, ed. *The Relevance of Models for Social Anthropology*. London: Tavistock Publications, 1965: pp. ix-xl.
6. Giddens A. *The Constitution of Society: Outline of the Theory of Structuration*. Cambridge: Polity Press, 1984.
7. Kirke C. "A Model for the Analysis of Fighting Spirit in the British Army", in Strachan H, ed. *The British Army, Manpower and Society into the Twenty-First Century*. London: Frank Cass, 2000: pp. 227 - 241.
8. Killworth P. *Culture and Power in the British Army: Hierarchies, Boundaries and Construction*. Cambridge: Cambridge University PhD Thesis, 1997.
9. MOD. *The Queen's Regulations for The Army 1975 (Including Amendment 24)*. London: HMSO, March 2001.
10. MOD. *Manual of Military Law Part I, 12th Edition*. London: HMSO, 1 May 2001.

11. MOD. *The Drill Manual*. D/DAT/13/28/97. 1990.
12. Geertz C. 'Form and Variation in Balinese Village Structure'. *American Anthropologist* 1959; **61**:pp. 991-1012.

APPENDIX C: SAMPLE INTERVIEW QUESTIONS

In most cases, I began the interviews by asking the interviewee to tell me when he or she joined the Army and to tell me about his or her service so far. In some cases, this provided a sufficient framework, with supplementary questions from me, for the whole interview. In others, I asked questions aimed at getting them to speak about the details of daily life in their experience and thus to explore with them the structural elements of their relationships with other soldiers. Examples of these questions are:

To Privates, NCOs and Warrant Officers

When you arrived in your unit, how did you become accepted by the people who were there already?

Were some of your fellow soldiers obviously more powerful and influential than others? What made the difference between those who had power and those who had not?

What makes somebody have an easy time settling in, and what makes them have a hard time?

When people eat together, is there a pattern as to who sits with whom?

When people go out together, is there a pattern as to who goes out with whom?

Are there any groups of soldiers in your [company/squadron/battery] who are always together? Why do you think that they stick together?

What makes soldiers stick together?

Which parts of the regiment/battalion do your friends come from?

Does anything change between a group of friends if one of them gets married?

What do you call the Junior NCOs? Is there a difference on and off duty?

Could a private/NCO be friendly with a Senior NCO/Officer? Where, in your opinion, are the limits?

What do you call the Senior NCOs? Is there a difference in different circumstances?

What difference does it make to a soldier when they are promoted to Junior NCO/Senior NCO?

How do you get on with people senior/junior to you? How do you relate to them? What sort of conversations would you have with them?

Are soldiers joining today different to how you were when you joined?

Who organises the cleaning routine in your barrack block? On what basis are the jobs handed out?

What sort of things divides people who have been friends?

What, in your opinion, makes a good officer/NCO?

What, in your opinion, makes a bad officer/NCO?

When you are off duty, what do you wear?

What do you expect an officer/soldier to wear off duty?

What do people do when they get angry with one of the hierarchy?

What happens if someone in authority gets things wrong? How are they corrected?

Is there any characteristic that stands out in your battalion/regiment?

What are the common experiences of people in your battalion/regiment/battery/squadron/company?

Which is the best sub unit in your regiment/battalion?

Can you describe the daily routine of your company/squadron/battery?

To Officers

I asked many of the same questions in the previous list, suitably modified for the new context. In addition, I also asked questions like those which follow more often of officers than soldiers:

How well do you get on with your platoon sergeant/company sergeant major/etc?

What happens in all-ranks parties/smokers etc?

How important is the history of your regiment/battalion/squadron etc?

How well do you get on with [a senior officer]?

What makes for good and bad morale in your regiment/battalion?

Do officers share personal difficulties with each other?

What do you think of the regimental system?

What are the main differences between [x unit and y unit] in which you have served?
How well do you know the details of your soldiers= everyday lives?

How is discipline in your battalion/regiment actually controlled?

If there was a really incompetent OC, how would he be sorted out?

Do the soldiers laugh at the officers?

When, if ever, would you address a junior soldier by a nickname?

What role do the senior private soldiers play in your battalion/regiment?

How can soldiers communicate informally with their superiors?

Description of the Model

From time to time I described the model to some of the interviewees, choosing a cross section of ranks and cap badges. Without exception these interviewees agreed about the value of considering the four separate social structures. The more detailed part, breaking down the informal structure into different types of relationship, was considered to need improvement at the start of the study. However, after it reached the form it is presented in this thesis it was accepted as readily as the four-structure model. There was general agreement wherever I went that these two models described the interviewees= lives well.

APPENDIX D BACKGROUND INFORMATION ON THE STRUCTURE AND ORGANIZATION OF COMBAT ARMS UNITS IN THE BRITISH ARMY

This appendix is for those who are not familiar with the organization of the British Army combat arms units. It provides a sufficient (though highly simplified) description of the rank structure found at unit level and basic elements of unit organization.

The Rank Structure of the Units in the British Army

A >unit= is a formally organized body of soldiers between approximately 400 and 600 strong commanded by a lieutenant colonel. It is the largest military group within the terms of reference of the study, and is generally considered within the Services as the basic group out of which operational military forces are built. Each individual in the unit has his seniority and responsibilities encoded in a military rank, and it is this structure of rank that this appendix describes.

The structure of the system of rank throughout the units of British Army is identical, so that soldiers of the same rank are given similar responsibilities and are paid the same. However, the details of the nomenclature varies between types of unit - and indeed between units of the same type with different history and traditions. This appendix provides a sufficient summary of the rank structure to enable the non-military reader to understand the thesis, but it is not a complete guide.

The main categories of rank and their sub-divisions are as follows, starting from the most junior:

Other Ranks

Private Soldiers

Junior NCOs

Senior NCOs

Sergeants

Warrant Officers

Commissioned Officers

Junior Officers

Field Officers

Senior Officers

Table 1

The nomenclature of rank in the combat arms units is shown in the following table. The seniority of the rank increases down the table.

Rank Category	Royal Armoured Corps	Royal Artillery	Royal Engineers	Infantry	Royal Signals	Army Air Corps
Private Soldier	Trooper	Gunner	Sapper	Depends on regiment. Examples are: Private, Fusilier, Rifleman	Signaller	Airtrooper
Junior NCO	Lance Corporal	Lance Bombardier	Lance Corporal	Lance Corporal	Lance Corporal	Lance Corporal
Junior NCO	Corporal	Bombardier	Corporal	Corporal	Corporal	Corporal
Sergeant	Sergeant	Sergeant	Sergeant	Sergeant	Sergeant	Sergeant
Sergeant	Staff Sergeant	Staff Sergeant	Staff Sergeant	Colour Sergeant	Staff Sergeant	Staff Sergeant
Warrant Officer	Warrant Officer Class 2 ¹	Warrant Officer Class 2 ¹	Warrant Officer Class 2 ¹	Warrant Officer Class 2 ¹	Warrant Officer Class 2 ¹	Warrant Officer Class 2 ¹

NOTES

1. Written >WO2=, but never called AWO2≅. Always formally addressed as ASergeant Major≅, or by his appointment, such as ACSM≅ which stands for >Company Sergeant Major=.

Rank Category	Royal Armoured Corps	Royal Artillery	Royal Engineers	Infantry	Royal Signals	Army Air Corps
Warrant Officer	Warrant Officer Class 1 ²	Warrant Officer Class 1 ²	Warrant Officer Class 1 ²	Warrant Officer Class 1 ²	Warrant Officer Class 1 ²	Warrant Officer Class 1 ²
Junior Officer	Second Lieutenant ³	Second Lieutenant ³	Second Lieutenant ³	Second Lieutenant ³	Second Lieutenant ³	Second Lieutenant ³
Junior Officer	Lieutenant ³	Lieutenant ³	Lieutenant ³	Lieutenant ³	Lieutenant ³	Lieutenant ³
Junior Officer	Captain	Captain	Captain	Captain	Captain	Captain
Field Officer	Major	Major	Major	Major	Major	Major
Senior Officer	Lieutenant Colonel	Lieutenant Colonel	Lieutenant Colonel	Lieutenant Colonel	Lieutenant Colonel	Lieutenant Colonel

NOTES:

3. Together Second Lieutenants and Lieutenants are known as Asubalterns≡, sometimes shortened in speech to Asubbies≡. They are formally addressed as AMister≡ plus surname.

2. Written >WO1=, but, like the WO2, never called AWO1≡. A WO1 is usually formally addressed either as AMister≡ plus surname, or by appointment, such as ARSM≡ which stands for >Regimental Sergeant Major=.

The Organizational Structure of the Combat Arms Units of the British Army

The combat arms units of the British Army are all divided on broadly the same pattern, but the nomenclature varies between types. The basic principles are:

- All units are divided up into a structure of ever greater numbers of smaller sets of groups, so that the pattern resembles a pyramid.
- There is a prescribed level of rank to command each size of group, and the smaller the group the more junior the rank of its commander.
- Every commander has a second in command, who is junior to him.
- In every officer's command there is a senior NCO, with whom the officer works closely.
- A subaltern's command may be commanded by a warrant officer or senior NCO. Otherwise, all commands are tied to the prescribed rank.

Table 2 on the next page gives the names of the various sets of groups, listed under the headings of the combat arms that they are typical of.

Table 2

The categories of groups to be commanded are as follows, in decreasing order of size going down the table:

Royal Armoured Corps	Royal Artillery	Royal Engineers	Infantry	Royal Signals	Army Air Corps	Quantity (approximate) per previous level	Commander's Rank
Regiment	Regiment	Regiment	Battalion	Regiment	Regiment		Lieutenant Colonel
Squadron	Battery	Squadron	Company	Squadron	Squadron	Four	Major
Troop	Troop	Troop	Platoon	Troop	Flight	Three	Captain or Lieutenant, depending on type
Tank	Section	Section	Section	Section		Two or three, depending on type	Sergeant or Corporal, depending on type

The details of the organization of a particular unit can change with the role to which it is assigned, and to a certain extent with the ideas of different commanding officers. However, for the purposes of the thesis the basic principles of unit organization should be seen as unchanging - or at least as changing so slowly as to appear stable.

The following two pages give (very simplified) examples of the structure of an artillery regiment and an infantry battalion.

Illustrations

As an illustration, here is what is known in the Army as a >wiring diagram=, or >family tree= of an artillery regiment:

27 Field Regiment, commanded by a lieutenant colonel, with a major as second in command

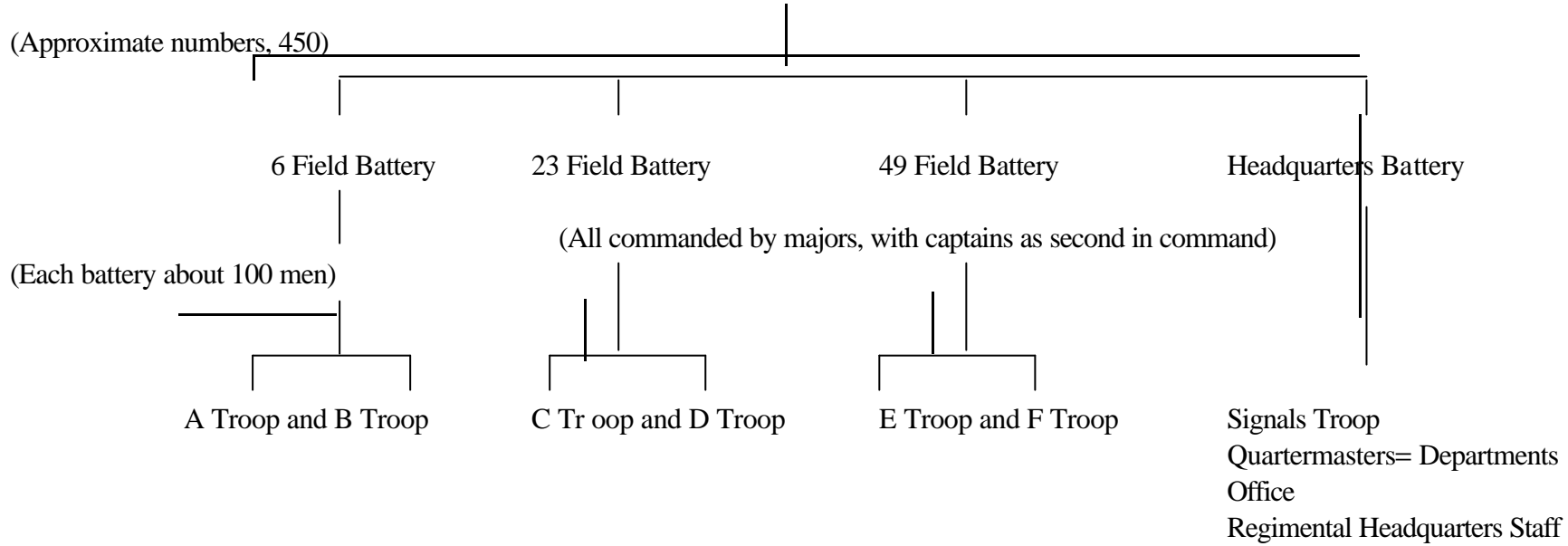

(All troops commanded by captains, with either a subaltern or a senior NCO as second in command)

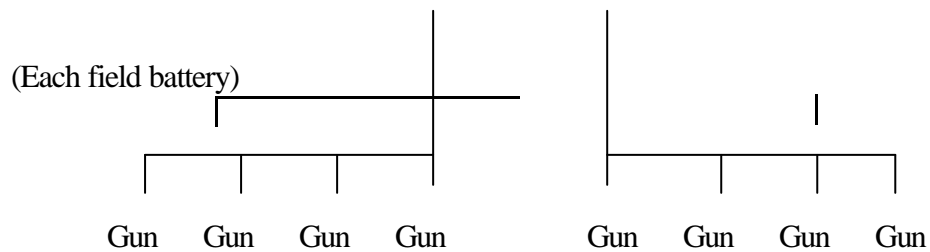

Note that this simplified organization chart omits other components of the battery, such as the administrative and command elements.

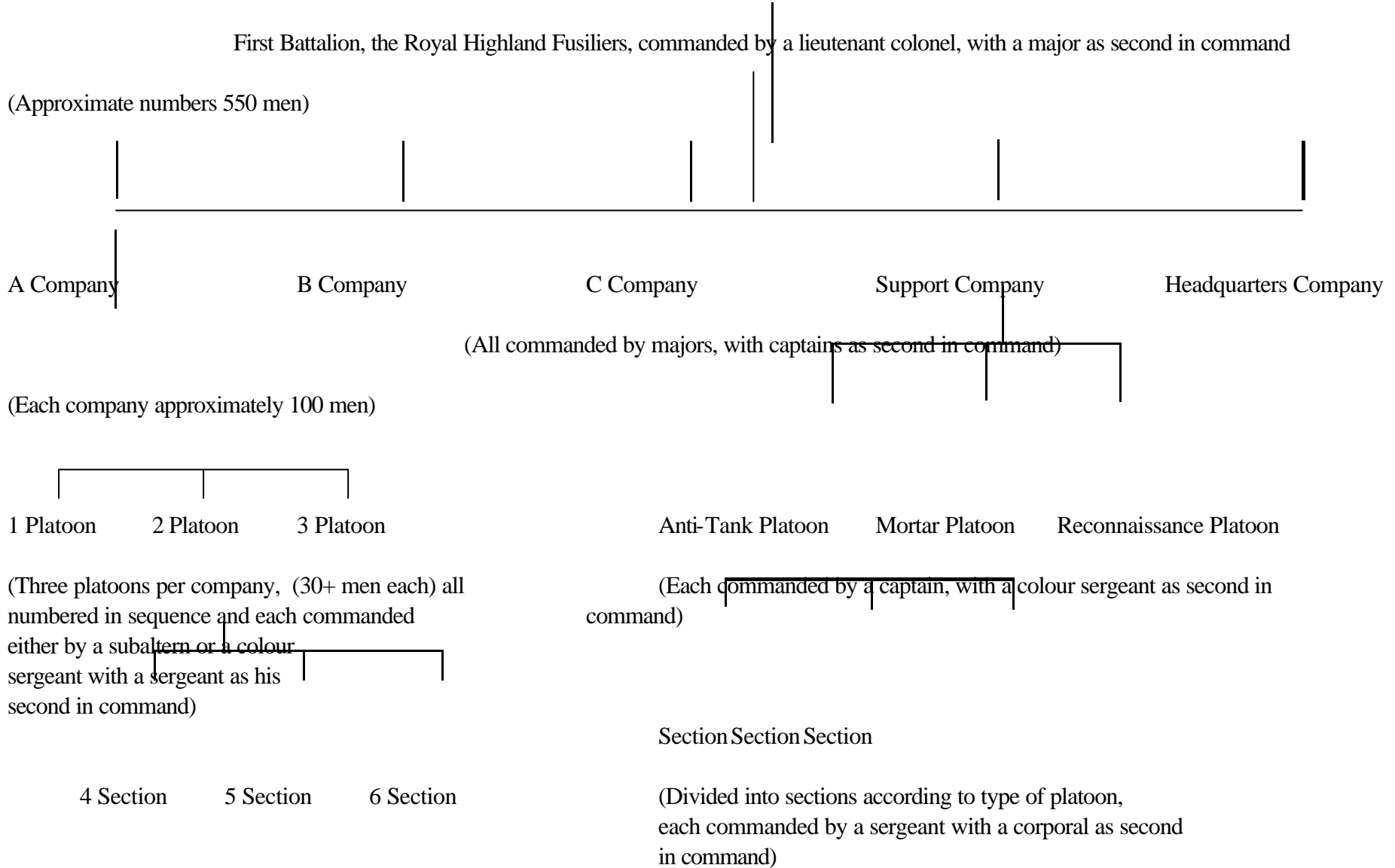

(Three sections (8+men each), all numbered in sequence,
per platoon each commanded by a corporal
with a lance corporal as his second in command)

*[Note: infantry platoons are usually reorganised for Northern Ireland into
two >multiples= of 4 x four-man patrols. The platoon commander commands
one multiple, the platoon sergeant the other.]*

APPENDIX E: LIEUTENANT COLONEL DALZELL'S LETTER 24 JANUARY 1855

This appendix contains the text of a letter by Lieutenant Colonel the Honourable Robert Alexander George Dalzell, written after his regiment, 63rd Foot had ceased to be effective in January 1855, reproduced from Mawton, M. H., “‘Not a Very Nice Regiment’: Her Majesty’s 63rd (The West Suffolk) Regiment of Foot’ *Journal of the Society for Army Historical Research* LXXVI, 1998, pp. 73-87.

The letter is addressed to Major-General Sir John Campbell, Bt. General Officer Commanding the 4th Division, to which the 63rd belonged. Mawton has retained ‘all idiosyncrasies of grammar, spelling and punctuation ... except where they obscure the author’s meaning (p. 76)’.

It is used as an illustration of analysis using the model. Analytical observations are inserted into the text in **bold**, preceded by the word ‘**Comment**’.

Balaklava Janry 24th 1855

Sir,

I had the honor of receiving last evening your letter of the 21st inst., transmitting ‘the Report of the Adjutant-General of the Army after he had inspected the Regiment under my Command (on the 15th inst.) and calling upon me for a full explanation of the causes which may, in my opinion, have led to its present inefficient state, as well as of those irregularities to which the Report refers, and for which I must be held to be more immediately responsible’.

I shall not trouble Field-Marshal Lord Raglan, or yourself, with many introductory observations or assurances of the deep regret I feel that such a report should have been made of a Regiment with which I have any connection, or to pourtray the distress and anxiety of mind I have been undergoing for weeks past whilst observing the rapidly increasing inefficiency of the Corps, and awaiting the moment which I foresaw must arrive when I should have to render an account of my charge.

Both His Lordship and your self will, I am sure, sympathize in my position, (to render which *most thoroughly painful* there is but one item wanting - the disapproval of my own conscience!) especially when I state that I am reduced to the alternative of either lamely surrendering the professional character, which, for twenty years, I have been endeavouring to establish for myself, or, in defence of it, to impute blame, if not directly, at least by implication, to other Officers, whom the robbery of reputation would probably leave, like myself, poor indeed!

Of these two courses, I am compelled to prefer the latter.

I have served nineteen months with the 63rd Regiment, but have only been responsible for its efficiency since 5th November, having early in the day at the Battle of Inkerman succeeded to the command on the death of the late lamented Lieut. Coll. Swyny.

I cannot suppose therefore that F.M. Lord Raglan, or yourself, will be of a different opinion from the

several Officers of Rank who have soothed me with their conviction that I cannot fairly be held blameable for much of what may be unsatisfactory in the state of the Corps, or that, as a new Commanding Officer - I could be expected during a period of unmitigated suffering and downward career of nearly, (if not) every Regiment in the Crimea to put an indifferent Corps to rights, or even to maintain things as they were. Had I any doubt on this subject, I could not in justice to myself abstain from preferring a request that the case should be thoroughly investigated by a Court of Enquiry, - and indeed should I fail in now submitting such a statement as may exculpate me to that extent, and secure me from the additional anxiety of a further enquiry by a long correspondence or otherwise, I trust His Lordship will be pleased to place that method of self-justification at my disposal at his earliest convenience.

The causes that have led to the present lamentably inefficient state of the 63rd Regt have, in my opinion, been

1st Its want of good system.

In this view I am borne out by the remark of the Officer Commanding the Brigade, with which it has just ceased to serve. Colonel Garrett 'I was sure you would have a great deal of trouble with the 63rd the result of indiscipline for years past.'

2nd The badness of its material.

3rd Singularly adverse circumstances.

With reference to the first, my earliest insight into the interior economy of the Regiment convinced me that it was below par.

"To all intents and purposes it was an 'easy going' Regiment and a system of rule, hot and cold alternately, had produced the usual effect.

[Comment: *Formal command structure not working as it should - not setting unambiguous limits and prescribing behaviour.*]

The body of Officers was composed, in an unusual proportion, of those who for private convenience had exchanged into it, - (of the Captains seven have done so). The absence of any sentiment akin to 'esprit de corps' was very palpable,

[Comment: *No evidence of loyalty/identity structure among the officers.*]

and for a long time I was really unable to discern, what is generally easily discovered, whether there were any, and what, Officers zealously and heartily attached to the Service, and eager for advancement. Two Comps were certainly in better order than the rest, and I gladly adopted the belief that their Captains were of the stamp I wished to find. In lieu of such stimulants to exertion and the correct performance of duty, I found a general indifference, indolence, and carelessness,

such as I had never seen equalled during my intercourse with many Regiments which I had known more or less intimately in Garrisons, and elsewhere -

[Comment: *Functional structure: officers not stressing the importance of 'doing the job' and not demanding that the soldiers were functionally proficient. This would have tended to undermine the *raison d'être* of a unit on operations.]*

such an idea as a prevalent desire and effort to establish and maintain their own particular Regiment on a footing, equal if not superior, to other Corps, never once betrayed its existence - and this living almost exclusively for self from day to day, and the total absence of 'esprit de corps' is one of the greatest obstacles in the path of its Commanding Officer at this moment.

[Comment: *No feeling of competition with other units - loyalty/identity structure deficient.]*

I am bound, on the other hand to remark that the utmost cordiality in social intercourse has been characteristic of the Officers of this Regiment, that their errors have been rather those of omission rather than commission, professionally, and that I dare say several Officers of fair promise would have come to light had military predilections been fostered from the earliest period of their career, and the conviction forced home amongst them, that to continue receiving pay whilst performing duty at best luke-warmly is not proof of spirit. Such having been neglected, they have habitually performed their duties loosely and carelessly, (I speak, not without an exception, but of the great majority.) - The Non Commnd Officers observing this as they could not fail to do, imitating a bad example, fell into similar ways, and allowed irregularities to pass unnoticed for the sake of an easy life - and became convinced that the Regiment did not honestly deserve what alone I had ever heard mentioned in its praise, viz, 'that it was very well behaved'.

[Comment: *Informal structure acting as a channel for the message from the officers downwards that formal command and functional standards need not be enforced.]*

Crime was screened not suppressed. Habits of respectful alacrity and implicit and ready obedience could not be expected among the Privates, not of extreme cleanliness and regularity. On such a defective basis, as this, the Regiment was thrice augmented from the very scum of Dublin.

[Comment: *Formal Command structure not being exercised. Too many legitimate secondary adjustments.]*

Decay is often insidiously at work within whilst the outside for a while looks fair enough - so it was with this Regiment, but only to make its annihilation more complete. It managed however to hold together, and to escape downright disgrace until it became my unenviable lot to be at its head, though it assuredly bore no high place in the estimation of Major-General Cochrane, in whose district in Ireland it was when I first joined it. In February we gave away Volunteers to Regiments destined for Turkey. The number was not large, but the men were of the best, - formed soldiers, who would be valuable on active service, - Lieut. Cl. Swyny, an Officer of the most scrupulous honor, making it a sine qua non that none of indifferent character should be offered as transfers. In

the same month the 63rd itself was ordered to augment and twice more in April and May first to 1000, then to 1200 and lastly to 1400. Of these mostly recruits, 148 were under 18 years of age, and nearly all our recruits were gathered from the riff raff of the Irish Metropolis, morally and physically the least desirable kind of Recruits a Regiment could be liable to enlist. Petty theft became most prevalent amongst us from that time, and much of the after confusion in the Corps was caused by the pilfering of these young soldiers, and their incorrigible propensity to use, if not to steal, their Comrades Arms, necessaries, Rations etc. whilst such practices were feasible, these Recruits managed, though always lazily, to turn out for duty, but when, as became the case, honest individual exertion was requisite to maintain not only appearances on Parade, but actual existence such as the labor of wood and water carrying etc. etc. these helpless, ignorant and indolent fellows rapidly became noneffective. It may be inferred what these men physically were from the Adjutant Generals Report that the men whom he inspected on Parade, and who had outlasted the others were 'undersized and not fit for the Service at all'.

The augmentations were doubtless conducted injudiciously fast, - but the desire to complete to the War Establishment was predominant, - and the how was not sufficiently attended to.

[Comment: The removal of experienced and regimental-minded soldiers removed a steady influence from those who remained. This influence would have been exercised through the *informal* and *functional* structures.]

[Comment: The regiment was too full of those who preferred *secondary adjustments* to *functional* proficiency. This indicates faults in the *functional structure*, and an imbalance in favour of the *informal structure*.]

We happened to be stationed in the Linen Hall Barracks, avowedly the least respectably situated in Dublin, as also the least favorable for converting Recruits into useful Soldiers. Their old haunts and associates remained within easy access whilst the only Drill ground was remote and the Barrack itself not such a school as was most likely to impress on a Recruit how clean and regular a Regiment, and each individual member of it, could, and ought to be.

[Comment: The soldiers were open to influences outside the military structures that acted contrary to the establishment of a positive unit identity.]

After fruitless efforts to get our station changed to the Royal Barracks where the 63rd would have been under the eye of the General Officer, one wing was dissevered from Head Quarters by being sent to Cork. The other ere long followed, and thus concentrated under very favourable local circumstances, had the Corps been allowed a month or two for training, its claim to discipline and efficiency might in a degree have been established, but unfortunately in ten days it embarked for Turkey. This embarkation was such a failure, as can never be forgotten by those who witnessed it! The Ship Avon was not calculated to hold the 1200 men (200 of the 46th Regiment included) who were ordered into her, but the confusion of our Embarkation which displeased Major-General Maunsell and the Asst Quarter Master General extremely was unquestionably attributable less to that than to the deficiencies of the Regiment, as a Regiment. Officers, and NonCommnd Officers

careless, inattentive, and not professing authority over their men, and the men themselves in great part raw, ignorant, brutish towards each other, headstrong and unmindful of the orders of their superiors.

[Comment: Faults in the *formal command structure* at both officer and NCO level, left the men in an undisciplined atmosphere.]

To get such Soldiers into their proper places, as also their Arms, Accoutrements, etc. was not to be accomplished even after disembarking, and marching on board a second time. I was so impressed with the unhandiness of the Regiment, that I stated to the Asst Quarter Master General and the present Asst Adjutant General in Edinburgh, who accompanied us down the river, that in my opinion, the Regt was quite unfit for active service.

[Comment: Faults in the *functional structure* were making themselves apparent. It seems that not only were the soldiers badly trained, but that they had no mature mental model of what constituted soldierly behaviour.]

Despite the vast quantity of Gunpowder on Board, the crowded state of the decks, especially at night, and the inevitable confusion, dirt and irregularity that prevailed during our Voyage, notwithstanding daily Parades and most uphill endeavours to bring men and things into shape, we reached the Bosphorus without an accident, and some days afterwards encamped in the Sultans Valley near Beycos. There an improvement was progressing, and something was being learnt, but our sojourn was very brief, and we re-embarked without effecting much towards efficiency, and landed in the Crimea on the 14th Sept. From that moment hardships and privations commenced and rapidly increased to their present extent, and the powers of a Regiment, constituted as this has been, composed in a great measure of the rawest, most helpless, most improvident, most indolent, and most undisciplined materials have been thoroughly overtaxed. Instead of being able to use, and profit by, and render available, resources already existing in the Regiment, those resources have had to be created at the very period when they were most needed in their utmost perfection. Whilst a childlike helplessness, and want of physical stamina amongst the men hung like a log round the neck of their Commanding Officer, no Childlike freedom from crime made amends for them morally! A hard days work under a broiling sun on the beach near Lake Touzla, w[h]ere the 63rd was left in rear of the Army collecting scattered stores etc. ready for reshipment, was the precursor on the 19th Sept. of a first days march through an enemys country, which did not terminate till late at night. Next day when we were expecting every minute to reach our final halting place, an inspiring address from Brigr Genl Torrens led the Regiment on for miles with the object of participating in the Battle of the Alma - but this most severe march before so many young soldiers had recovered from the first day, which is avowedly the most trying of a march on all Troops,

[Comment: Dalzell is calling on a shared model from the *functional structure*.]

was quite too much for them, and combined with copious draughts of cold river water from which neither persuasion nor force could turn them when heated caused Cholera to break out amongst us

next day. Its ravages led to our removal to the heights and when the Army moved forward, the 63rd was still the Rearmost Regiment of the column which was not in favor of inexperienced marchers.

During the fortnight of comparative inactivity after the 4th Division took post before Sebastopol, there was not that improvement in the appearance of the 63rd Soldiers that we had hoped for. Naturally deficient in Stamina and unacquainted with those means of husbanding their strength and 'saving themselves' that older Soldiers acquire, there was an exhausted look about our many young Soldiers - and this had not disappeared when the Duty of the Trenches commenced. It was not likely to do so from that time. During the fatigue of the march, most of the Camp Kettles had been thrown away, indeed rather than be late for a share in the Battle of the Alma, the Soldiers had been directed to discard anything that they could not carry, and the Camp Kettles, from their unwieldiness and, as compared to great Coats and Blankets, valuelessness, had gone first. This has ever since been a mis-fortune. For long after our arrival before Sebastopol, fresh ones were not forthcoming, - the regular system of cooking by messes was interrupted, and when each man had to look out for his own meals, the many indolent men mostly went without more nutritious fare than biscuit. Soon after fresh Camp kettles had been issued, fuel became scarce, - at least dry fuel, and latterly fuel of any kind.

[Comment: The absence of stable eating/messing groups would have adversely affected informal bonding in the *informal structure*. If the soldiers were each on his own in looking for food, it was a bad sign as far as the informal structure was concerned.]

On the 5th November was fought the Battle of Inkerman. In my return to Camp that Evening as Commanding Officer of the 63rd, I had no reason to congratulate myself under the auspicious circumstances under which I commenced my responsibility. I was the only Field Officer present. All the Captains were wounded or absent sick, except three, (one of whom left for Scutari sick in ten days and has never since rejoined) the Adjutant was wounded, and left immediately with the other wounded officers, and I had to look (where zeal, as I have already asserted did not abound) for a Subaltern to act in his stead, who, when found, was quite ignorant of his new duties. The Regiment had been without a Sergeant-Major since our landing at Lake Touzla, - of Pay and Colour Sergeants, on whom so much depends whether the Captains are zealous or not, there were only three not wounded or sick, and one of these having to act as Sergeant-Major was thenceforth but little with his company.

[Comment: We do not know how many of the Senior NCOs were non-effective before Inkerman, but this implies that there were enough of them up to the battle.]

[Comment: The absence of senior NCOs after Inkerman could well have contributed to the subsequent collapse of the battalion. Their influence would have been missed in all four structures.]

[Comment: So far, it is clear that the lattice of informal relationships that might have been expected to be operating was much less effective in supporting military performance than

in a 'typical' regiment: the old soldiers who might have acted as role models for the new men had been reduced in numbers, the largest peer group consisted of the new locally-recruited (Irish) men, group bonding round eating arrangements was not taking place and, according to the CO, the NCO's were not setting an example of behaviour - and by not doing so were sending an informal message that 'soldierly' behaviour was not required.]

The Paymaster had been left on board ship, sick, with his clerk. The first I have never seen since, the last has only recently rejoined and has again left sick. Their Books papers etc., and indeed all the Regimental Documents passing through their Department were accidentally (as appeared before a Court of Enquiry which I assembled,) burnt on the 5th Decr when they had just been transferred by the Paymaster at Balaklava on his way to England, to the Committee of Paymastership, whereby the Regimental Pay Lists are six months in arrear!

Whilst there was this paucity of auxiliaries to assist me in conducting the business of the Regiment, there were men enough left, and of the class to require much supervision and correction.

On the 14th Novr the terrific Gale blew down all the Tents of the 63rd which were on the very exposed top of the Hill. Many were greatly damaged and had to be used in a very tattered state, the requisite number of new Tents not being immediately issuable. The General impression then was that this was but the first of a series of Gales to which we should be subjected, and as there was no likelihood (from enquiries that I made of the Asst Quarter Master General) of the troops being soon hutted, I caused holes to be dug wherein to sink the Tents which thus became much less exposed to the winds, and these same holes, by throwing a wall of stones or earth across, could be readily roofed over should wood be forthcoming.

The wet weather, however, overtook us before the original plan of drainage could be effected, and it was necessary to shift the Tents on to the high ground again. The exposure of that night sent many men to Hospital, and laid the seeds of much sickness besides, combined with other after causes such as the frequency and severity of duties, not only in the Trenches but on Fatigues to Balaklava, conveying back to Camp Clothing Wood Food etc. etc. for which Beasts and Carts were not to be had. The Sick List of the 63rd at once ran up to a high figure, and my means of carrying on the duties of the Regiment became fewer and fewer, and my difficulties greater and greater, as the weather grew worse and the Sick List increased, whilst Rations at times were insufficient and irregularly issued and duty painfully severe. (In six days I have myself had three tours of duty in the Trenches and after passing a night (when not sliding or staggering my Rounds over the slushy and slippery ground) sitting or lying in a pool of mud to which a ditch in England would be a paradise in comparison, I have returned to my Tent, not to rest for even a few hours but to resume my Orderly Room and other Regimental Duties, and to note that my cases were not diminishing nor my prospects improving, but that during every absence some more men had gone sick, if not died, and my Dutymen consequently become fewer).

[Comment: Under these testing conditions, all the *social structures* would need to be operating strongly in the lives of the soldiers to retain their regimental solidarity and their application to military duty. The other battalions in the area were under the same physical

pressure but presumably they had stronger *social structures* that brought them through in a better state.]

The great majority of the men of the 63rd were Irish, and the same natural indolence, dirty habits, want of forethought and defects of character that have had so much to say to Ireland's backwardness as a Nation, have produced their effect in the smaller compass of a Regiment.

[Comment: Dalzell is invoking a cultural stereotype here, but it may be that the national culture from which these soldiers came made it necessary to change their *habitués* to make them value and aspire to soldierly qualities. Such a change would normally have been brought about through recruit training, which he has already pointed out was too short to be successful.]

To awaken the younger soldiers to smartness and other soldier-like qualifications some months ago was a most difficult task though they were in health, - when unaided by the example of a fair proportion of pattern men, which, as already stated, did not exist in the 63rd - to arouse them to any effort or exertion whilst under the influence of incipient sickness became really impossible at last despondency took hold on the men - and it appeared their determination to die - rather than struggle to live - and so fast did they die that the Surgeon (from whose Medical skill alone I could expect much owing to the (sole present) Asst. Surgeon's being less than a year in the service) became mentally prostrate and was ordered away by a Medical Board.

Since then two Surgeons from the Staff have successfully been attached to take charge of the Hospital, which was cleared by their sick being sent to Scutari before we moved to Balaklava on the 20th inst.

I have omitted to mention as unquestionably bearing on the subject of causes of the present inefficiency of this Regiment, that the practice of Non Comm'd Officers and other obeying orders implicitly and with the utmost despatch if it ever existed in the Corps, had fallen into desuetude before I became acquainted with it. I need not enlarge upon the train of evil consequences that must result from a disregard of the maxim that 'obedience is the first duty of a Soldier'.

[Comment: *Formal Command Structure* not working.]

When an officer in any position of authority such as mine cannot rely on the punctual fulfillment of his orders, the contretemps and irregularities and neglects that constantly come to light involve him in almost inextricable difficulties and the wear and tear of mind and body is doubled and is enough to break down not only the best intentioned, but most able man. It can hardly I presume be supposed that whilst this decay of the 63rd Regt has been going on with equal rapidity and certainty, of late, I, its Lieut Colonel could only look on unconcernedly absorbed in my own private affairs, or be otherwise than deeply affected not only at its progress, but by my inability to stay it in any degree!

And surely, Sir, it can no longer, if you credit my statement, be matter of surprize to F.M. Lord

Raglan or yourself that an Inspecting General should have been unable to represent what remains of the Regiment under my Command in the Crimea in a more satisfactory light, or that some traces even should betray that I may myself have succumbed to the force of adverse circumstances, and have not been able to display uninterruptedly, energy - almost superhuman! That I have at least stuck to the post of Duty and considered my Regiment as of paramount importance has been proved by my having only twice quitted the Camp since the 5th November - once to ride to Balaklava on business, and once for a couple of hours walk to dissipate my isolated wretchedness at the continued downward course of the Corps - notwithstanding my earnest, zealous and best intentioned efforts and designs for its benefit! I appeal to His Lordship's and your sense of justice to decide whether because some irregularities may have attracted the notice of the Adjutants General of the Army, it is any proof that I have been guilty of general neglect of duty, to Her Majesty, my Regiment, and yourselves, or whether I can fairly be blamed for the inefficiency of a Regiment, the seeds of whose decay were sown before I became its responsible head!

With reference to 'those irregularities for which I must be held more immediately responsible' I beg to offer the following remarks in addition to what has gone before explanatory of them in some measure.

The Arms and Accoutrements of some of the few men under Arms for the Adjutants Generals inspection had not been long in their possession. The History of our Arms and Accoutrements is complicated. During the march on Sebastopol men at various times fell sick and with their Arms and Accoutrements went on board Ship - When they rejoined the Regiment some had Arms etc. of one Regt, some of another, and some were no more wrong than that they had arms belonging to other Companies of their own Regiment, and on being taxed with carelessness in receiving other than their own proper Arms etc. they asserted that they had remonstrated without success. Some men being constantly absent on Duty it was no easy matter to effect even the exchanges between Companies especially as no Memd. [Memoranda, i.e. the Regimental Documents which had been accidentally burnt] were forthcoming of the number of each mans proper Arms and Accoutrements. Further confusion arose in the Trenches and indeed elsewhere from men snatching up A (and A) that were not their own - which was no more than one would expect from such imperfectly trained Soldiers as abounded in the Regiment who were prone to adopt the readiest means, right or wrong.

[Comment: The soldiers had not fully acquired the soldierly instinct to keep their own weapons and equipment close to them and treat them as vital personal property.

Functional structure.]

Again when after the Battle of Inkerman, I sent a party under an Officer to recover from the field whatever Arms etc. might be lying there belonging to the 63rd, instead of strictly confining themselves to what it was our especial duty not to be lost, they brought back property of other Regiments in many cases - not in addition to, but chiefly in lieu of what there was reason to believe they might have found!

Such were some of the causes of scarcely a single man having either the Arms and Accouts that were originally served out to him, or having even sets similarly marked which I wished for a long

time in vain to rectify. At last I succeeded in parading all the Arms and Accoutrements at once, and a re-issue in complete sets took place very shortly before the General Inspection.

The Arms and Accts had however been standing out for some days before the task could be completed, and had unquestionably got into a very bad state. I reckoned, notwithstanding the small number of men at my disposal, that by degrees I should get all well cleaned and regular. It was not however to be accomplished in a few days and the Armourer Sergeant falling sick, as everyone else did, exactly when I most wanted him, did not hasten the work. I had in truth detained the A and A for a while, after I became aware indirectly that surplus A and A were to be sent to Balaklava, feeling thoroughly ashamed to give them into Store in such a state! No order ever reached the Regiment to do so, and they had accumulated in such numbers owing to the Non Effective List swelling so fast, that I had not the means, for want of men of sending them to the Ordnance Stores afterwards. I was not present when the Adjutant Genl saw the Regiment and visited the Tents, but I believe that A and A in one of the unoccupied Tents to have belonged to men who that very day were sent away to Scutari without having been in Hospital at all for want of sufficient accommodation. This was an instance of so many Arms and Accouts being thrown on my hands simultaneously, that I had not enough Effective men left to convey them to Balaklava, even exclusive of previous accumulations. With regard to the Ammunition, it had been our practice to fill up such pouches of Effective men as required renewing from the pouches of Non Effectives, and the loose rounds were for obvious reasons taken first, at once destroying uniformity, but at no other cost in times when many loose rounds are soon fired away.

One of my earliest orders after assuming command of the Regt was as to the regulation of the Tents, - it was most specific, and I so far insisted on the Drainage in particular being secured that I would not allow the men to occupy the Tents on our new ground until a drain had been formed round each and such existed when the Adjutant General visited the Camp. The snow, however, had blocked them up I am well aware and had formed obstructions at the doorways by drifting, but besides the unfavourableness of the weather, the Regiment was so reduced in number and is dejected and worn out physically that that was not the first day when it had been found impracticable to maintain any semblance even of order and regularity in the Tents. To frustrate the endeavours that had been made to secure to the Regiment better health and more comfort, extreme indolence and obstinacy had been constantly at work. The spades and pick axes were wantonly but cunningly broken and secreted for fuel - and neither leniency nor punishment had effected much in improving the disposition of some of these ill conditioned fellows when they passed from my hands into the Hospital.

[Comment: The soldiers had placed their own physical needs above the military task. This indicates that the *functional structure* had collapsed.]

Were this a reply to charges of mis-rule distinctly brought against me, I should record how that I had remonstrated with, reprimanded and appealed to Officers, - reduced Non Comd Officers and flogged Privates until the Surgeon interfered, and left me too much at their mercy considering how few means of improving discipline are at the hands of a Regiml Commanding Officer on Active Service - which I beg to add to the list of adverse circumstances that have conduced to the present

inefficiency of the 63rd Regiment.

[Comment: Here Dalzell shows that he had tried several management techniques, some informal and some formal. The fact that none of them worked confirms that the *formal command structure* was not acting as a means to direct the men's behaviour and that he did not have sufficient links in the *informal structure* to improve things by that means. This may well have been through the loss of informal bonds because of the casualties.]

I have the honour to be

Sir

Your obedient humble Servant

Robt. A. G. Dalzell
Lt Col Comg 63rd Regt.

[Comment: The fact that he had to use several leadership techniques - and that this included 'remonstrating' and 'appealing' implies that his leadership and management techniques were not suited to the situation - but it was a very difficult situation for everybody concerned.]

APPENDIX F: A LEADERSHIP AND MANAGEMENT TRAINING MODULE FOR OFFICER CADETS BASED ON THE MODEL

The purpose of this appendix is to provide an illustration of how one of the leadership and management training modules for officer cadets at the Royal Military Academy Sandhurst (RMAS) might be constructed using the model.

The master format for all training in the Services is given by a Defence Council Instruction setting out the 'Joint Service Systems Approach to Training' (SAT)¹. Accordingly, the module generated in this appendix conforms to its provisions.

At the highest level within any SAT-compliant teaching module, there is a general 'training objective' (TO), defined as a statement that defines what the trainee should be able to do at the end of training. The current Leadership and Management Module TO reads,

'Demonstrate Leadership and Management'

Below the TOs comes the Instructional Specifications (ISpec), defining the 'content, structure and sequence of instruction', and providing 'instructors with the minimum information needed to deliver the training'. An important element in the ISpec is a suite of 'enabling objectives' (EO), which 'specify what trainees can do at the end of instruction that they could not do at the start', below each of which come 'teaching points' (TP) which 'are key points contained within the development of the section of the ISpec. In essence, TPs are short summaries of the contents of the teaching periods.

The area for leadership and management instruction which the model is best suited to inform is the realities of exercising leadership and management at regimental duty, which, according to Rodley's analysis² is an important missing area in the RMAS syllabus. Whilst he finds the theoretical instruction on leadership and management at RMAS is effective, he doubts the effectiveness of the current policy whereby the young officer is expected to acquire his or her leadership and management skills though 'on-the-job experience and Aosmosis³ through observation and subsequent emulation of one's superiors'.³

An EO to achieve the purpose of filling this gap might read:

'To understand the practical realities of life in a military unit.'

An important element in the construction of a teaching point is the length of the teaching period in the timetable. In the case of RMAS it is 45 minutes, which includes a time for questions during, and at the end of, the period⁴.

It is now possible to derive the individual teaching points to fulfil the EO, using the model to

construct instructional periods of 45 minutes. Making the reasonable assumption that up to seven periods could be made available to cover this enabling objective, the contents of these periods would cover:

Period One: Introduction. The context-dependent nature of life in a unit. The four-structure model, the concept of the *operating structure*. The importance of functioning successfully as a leader in all four structures so that whatever the context the leader is still dominant.

Period Two: The *formal command structure*. The need for an officer to issue orders clearly and authoritatively, to listen to reports from below, and to understand and obey orders from above. The importance of appearance and behaviour that is consistent with disciplinary customs of the unit. The importance to each soldier of his/her unique place in the unit with which that soldier identifies.

Period Three: The structure of the *informal structure*. The nature of the five-fold suite of informal relationships and their qualitative differences. Appropriate and inappropriate terms of address in different informal contexts. The nature of *legitimate* and *illegitimate secondary adjustments*, the importance of the individual's perspective on them, and who sets the standards.

Period Four: Appropriate behaviour for the *informal structure*. Building appropriate informal relationships. Examples: *association* with the senior NCOs in his sub-unit (and especially any under his/her command) *informal access* with his/her private soldiers, *friendship* with his/her follow-subalterns, and *association* or *informal access* with his/her sub-unit commander. *Association* to develop with his/her junior NCOs and private soldiers over time. The importance of not attempting to achieve, or encouraging the development of, inappropriate relationships such as *friendship* with NCOs or privates. Whose advice to take on the subject of *secondary adjustments*, and the establishment of a consistent personal policy for *secondary adjustments* and the *special informal circumstances* when the conventions of terms of address may be suspended.

Period Five: The *loyalty/identity structure*. Taking an active part in supporting the *loyalty/identity segment* that he/she commands, both during events where pride and prestige are at stake (such as competitions) and during celebrations of his segment's identity (such as parties). Taking an active part in supporting the segments above the one he/she commands, and acknowledging the soldiers' membership of the segments below the one which he/she commands and encouraging them in exercising their membership of them. The importance of the Regiment's/Corps', unit's, and sub-unit's history and traditions and of being seen to identify with them. The necessity of supporting all sporting occasions that any of his/her *loyalty/identity segments* partake in, and of participating in as many as he/she can.

Period Six: The *Functional Structure*. The importance of an officer performing his/her own function well, showing both personal (soldierly) skills, special-to-arm skills, and the ability to exercise professional military command effectively. The importance of an officer appearing soldierly. The importance of recognizing good performance and congratulating those who show it, and giving encouragement to those who fall short but in his/her judgement are trying to perform well. The need show concern for the maintenance and improvement of individual and collective training standards.

Period Seven: Discussion of issues with officers and NCOs with experience at regimental duty, to enable students to ask questions and test out the theory that they have been taught with practitioners in an informal atmosphere.

It will be seen that the contents of these teaching periods were generated entirely from the model, with the four *social structures* providing four useful main headings. The greater degree of detail provided by the lower levels in the model provides more focused information for the young officer to help him or her to understand the nature of life in a unit and what constitutes successful leadership and management. For instance, at the top level, the model indicates that it is important that the officer should be able to function successfully in all four structures: if he or she were not capable of functioning as a leader in some of the *social structures* then they would fail to lead successfully when any of them formed the *operating structure*. At a lower level, the more focused detail in the four structures would provide direct information and personal goals to do with elements such as what constitutes 'soldierly' tasks, the appropriate terms of address in different circumstances, and the importance of the different levels of *loyalty/identity segment*.

It remains to generate the seven 'teaching points'. The first consideration is that the contents of the seven periods laid out above needs to be summarised in short phrases. Secondly, as the enabling objective is couched in practical terms, it would be better if the academic language in the model were modified to give a more practical feel to the instruction. For this module, therefore, it is suggested that the four *social structures* are re-expressed in terms of simple verbal nouns which carry the message of what actions the leader has to take in each *social structure* to exercise their leadership skills, as follows:

Formal Command Structure: Commanding and Obeying

Informal Structure: Relaxing

Loyalty/Identity Structure: Belonging

Functional Structure: Doing the Business

and that *secondary adjustments* are treated as 'rule-bending'.

The finished suggested set of EOs and TPs is therefore as follows:

EO 8.*⁵: To understand the practical realities of life in a military unit.

TP		
1	Introduction	The importance of context. The four types of context. The concept of the dominant context (<i>operating structure</i>). The importance of functioning successfully as a leader in all types of context.
2	Commanding and Obeying	The flow of commanding and reporting. The duty of obedience. The importance of appearance and behaviour. The unique position of each soldier.
3	Relaxing (1): the system.	The structure of the informal activity. The five-fold suite of informal relationships and their qualitative differences. Appropriate and inappropriate terms of address. 'Legitimate' and 'illegitimate' rule-bending; who sets the standards.
4	Relaxing (2): how should the leader behave?	Building appropriate informal relationships. Whose advice to take about rule-bending. Establishing a consistent personal policy about rule-bending, and the special occasions when the conventions of terms of address may be suspended.
5	Belonging	Supporting the team that the leader commands in all types of context. Supporting the larger and smaller teams. The soldier's perspective. The importance of the Regiment's/Corps', unit's, and sub-unit's history and traditions. Supporting and taking part in sport.
6	Doing the Business	The importance of an officer performing his/her own function well and looking the part. Attitudes to the soldiers' and NCOs' performance. The need show concern for the maintenance and improvement of individual and collective training standards.
7	Discussion	Small group discussion with experienced officer and NCO about the practicalities of leadership and management at regimental duty.

Notes to Appendix F:

1. MOD, AThe Joint Service Systems Approach to Training (JS SAT) Quality Standard, *Defence Council Instructions, Joint Service*, 85 (1 June 2001),2001. The definitions which follow are all taken from page 9 of that publication.

2. Rodley, I. J., *Leadership Training and Development, a Thesis for the Degree of M.Phil, Lancaster*, Lancaster University, 1995.

3. These Conclusions appear in *ibid.* 185-191.

4. Conversation with SO2 Leadership RMAS, 5 March 2002.

5. The number to be added later by the person constructing the ISpec.

APPENDIX G: LETTERS SHOWING ACCEPTANCE OF THE MODEL BY MOD INSTITUTIONS

The attached letters show how the model has been received by the following MOD institutions:

The Tri-Service Equal Opportunities Training Centre, Shrivenham, dated 12 July 2002

Ministry of Defence, Directorate of Service Personnel Policy, dated 15 July 2002

The Royal Military Academy Sandhurst, dated 26 July 2002

Assistant Chaplain General, 4 Division, dated 26 July 2002

Photocopies of letters attached in the original

BIBLIOGRAPHY

AUTHOR'S FIELD NOTES

Note Books and Computer Files

Manuscript journal incorporating field notes; episodic, 1974 to 1989.

Field notes, originals in notebooks, consolidated into computer files; continuous, 1993 to 2002.

Interview Transcripts

Originals on audio tapes supplemented by notebooks, consolidated into computer files, comprising:

115 interviews with British soldiers (less Gurkhas) 1993 to 2002 (see Table 1.2, page 28).

13 interviews with members of the Gurkhas (4 British, 9 Nepalese) (see Table 1.3, page 29).

7 interviews with United States Air Force personnel (see Table 1.4 page 29).

4 group sessions (see Table 1.5 page 30).

PRIMARY SOURCES

Unpublished Primary Sources

Gardiner, I., *Some Realities of Command at Company Level in War*, unpublished lecture script delivered at Royal Military College of Science, Shrivenham, 2000.

Hanbury, J., *Donnie's War* unpublished memoir of the Second World War, 1939 to 1945, undated, *circa* 1965.

Kirke, R., *Aldershot to Anzio and Back Again, 1938 to 1944*, unpublished memoir of the Second World War, undated, *circa* 1992.

Royal Artillery Unrecorded Heritage (RA/UH), author's collection. Various dates, 1997-2002.

Published Primary Sources

- Anon., *A Royal Dragoon in the Spanish Succession War* (Atkinson, C. T. (ed.)), Society for Army Historical Research Special Publication No 5., 1938.
- Anon., *A Soldier of the Seventy-First: The Journal of a Soldier of the Highland Light Infantry 1806-1815* (Hibbert, C. (ed.)), London: Leo Cooper, 1975.
- Anon., *Memorials of Captain Headley Vicars, 97th Regiment*, London: James Nisbet & Co., undated.
- Anton, J., *Retrospect of a Military Life During the Most Eventful Periods of the Last War*, Cambridge: Ken Trotman, 1991.
- Bairnsfather, B., *Fragments from France*, London: The Knickerbocker Press, 1917.
- Bancroft, N. W., *From Recruit to Staff Sergeant*, Hornchurch: Ian Henry Publications, 1979.
- Barter, R., *The Siege of Delhi: Mutiny Memoirs of an Old Officer*, London: The Folio Society, 1984.
- Bishop, M., *The Life and Adventures of Matthew Bishop etc*, London: 1744.
- Blackader, J., *The Life and Diary of Lieut. Col. J. Blackader, of the Cameronian Regiment, and Deputy Governor of Sterling Castle, who Served with Distinguished Honour in the Wars Under King William and the Duke of Marlborough, and Afterwards in the Rebellion of 1715 in Scotland* (Crichton, A., (ed.)), Edinburgh: H. S. Baynes, 1824.
- Blaze, E., *Life in Napoleon's Army: the Memoirs of Captain Elzear Blaze*, London: Greenhill Books, 1995.
- Bowlby, A., *The Recollections of Rifleman Bowlby*, London: Cassell, 1999.
- Brotherton, T., *A Hawk at War* (Perrett, Brian (ed.)), Chipenham: Picton Publishing, 1986.
- Campbell, C. F., *Letters from Camp to his Relatives During the Siege of Sebastopol*, London: Richard Bentley and Son, 1894.
- Clifford, Henry, *Henry Clifford V.C. His Letters and Sketches From the Crimea* (Fitzherbert, Cuthbert (ed.)), London: Michael Joseph, 1956.

- Cooper, J. S., *Rough Notes of Seven Campaigns in Portugal, Spain, France and America During the Years 1809-1815*, Staplehurst: Spellmount, 1996.
- Craig, J., '>Extracts from Letters Written by Private James Craig to his Family from South Africa at the Height of the Boer War (edited by James Guild)', *The Journal of the Royal Artillery*, **CXXVII**, No. 2, 2000, pp. 42 - 44.
- Davenport, R., *To Mr Davenport, being Letters of Major Richard Davenport (1719-1760) to his brother during service in the 4th Troop of Horse Guards and 10th Dragoons, 1742-1760* (Frearson, C.W. (ed.)), Society for Army Historical Research Special Publication No 9., 1968.
- Dean, J., *A Journal of Marlborough's Campaigns During the War of the Spanish Succession 1704-1711* (Chandler, D. (ed.)), Society for Army Historical Research Special Publication No 12, 1984.
- Dickson, A., *The Dickson Manuscripts: Being Diaries, Letters, Maps, Account Books, With Various Other Papers of the Late Major-General Alexander Dickson, G.C.B., K.C.H., K.T.S., Royal Artillery, Series "C" - From 1809 to 1818* (Leslie, J. (ed.)) Cambridge: Ken Trotman, 1988.
- Dyneley, T., *Letters Written by Lieut.-General Thomas Dyneley C.B., R.A., While on Active Service Between the Years 1806 and 1815* (Whinyates, F. (ed.)), London: Ken Trotman, 1984.
- Evelyn, G., *A Diary of the Crimea* (Falls, C. (ed.)), London: Gerald Duckworth & Co Ltd, 1954.
- Eyre, V., *Journal of an Afghan Prisoner*, London: Routledge & Kegan Paul Ltd., 1976.
- Fraser, G. M., *Quartered Save Out Here: a Recollection of the War in Burma*, London: Harvill, 1992.
- Gatliff, H., *Stations, Gentlemen! Memoirs of James Gatliff* (Gatliff, H. (ed.)), London: Faber and Faber Limited, 1938.
- Gleig, G., *The Subaltern: A Chronicle of the Peninsular War*, London: Leo Cooper, undated.
- Godman, T., *The Fields of War: A young Cavalryman's Crimea Campaign* (Warner, P. (ed.)), London: John Murray, 1977.

- Gowing, T., *Voice From the Ranks: A Personal Narrative of the Crimean Campaign by a Sergeant of the Royal Fusiliers* (edited by K. Fenwick), London: William Heinemann Ltd., 1954.
- Graves, R., *Goodbye to All That*, Harmondsworth: Penguin Books Ltd., 1960.
- Griffiths, C., *A Narrative of the Siege of Delhi with an Account of the Mutiny at Ferozepore in 1857* (Yonge, H. (ed.)), London: John Murray, 1910.
- Gwynne, J., *Military Memoirs of the Great Civil War, being the Military Memoirs of John Gwynne; and an account of the Earl of Glencairn's Expedition, as General of His Majesty's Forces, in the Highlands of Scotland, in the Years 1653 & 1654 by a person who was eye and ear witness to every transaction. With an Appendix.*, Cambridge: Ken Trotman Ltd., 1987.
- Hale, A. M., *The Ordeal of Alfred M. Hale: Memoirs of a Soldier Servant* (Fussell, P. (ed.)), London: Leo Cooper, 1975.
- Hamilton, A., *Hamilton's Campaign with Moore and Wellington During the Peninsular War*, Staplehurst: Spellmount, 1998.
- Harris, B., *A Dorset Rifleman: The Recollections of Benjamin Harris* (Hatherway, E. (ed.)), Swanage: Shinglepicker, 1996.
- Harris, S. W., '>The Nile Expedition of 1898 and Omdurman - the Diary of Sergeant S.W. Harris, Grenadier Guards (Harris, J. (ed.))', *Journal of the Society for Army Historical Research*, **78**, 2000, pp. 11- 28.
- Hennell, G., *A Gentleman Volunteer: The Letters of George Hennell from the Peninsular War 1812-1813* (Glover, M. (ed.)), London: Heinemann, 1979.
- Hodgson, J., *Memoirs of Captain John Hodgson of Coalley-Hall, Near Halifax; Touching His Conduct in the Civil Wars, and his Troubles After the Restoration. Written by Himself*, Pontefract: Gosling Press, 1994.
- Holles, R., *The Guide to Real Subversive Soldiering*, London: Elm Tree Books, 1985.
- Hopton, R., *Bellum Civile: Sir Ralph Hopton's Memoirs of the Campaign in the West, 1642 - 1644* (Wicks, A. (ed.)), Leigh on Sea: Partizan Press, 1988.
- Image, J. G., *The Crimean Journal of Lieutenant Image* (Ross, D. (ed.)), Manitoba: Manitoba Museum of Man and Nature, 1971.

- Jocelyn, S., *With the Guards we Shall Go: A Guardsman's Letters in the Crimea 1854-1855* (Airlie M. (ed.)), London: Hodder and Stoughton Limited, 1933.
- Jones, D., *In Parenthesis: seinnnyessit e gledyfym penn mameu*, London: Faber & Faber Ltd., 1963.
- Kincaid, J., *Adventures in the Rifle Brigade and Random Shots from a Rifleman (abridged)*, Glasgow: Richard Drew Publishing, 1981.
- Kingsland, G., *In Quest of Glory*, Sevenoaks: Hodder and Stoughton, 1990.
- Lang, A. M., *Lahore to Lucknow: the Indian Mutiny Journal of Arthur Moffatt Lang*, London: Leo Cooper, 1992.
- Larpent, G., *The Private Journal of Judge-Advocate Larpent, Attached to the Headquarters of Lord Wellington During the Peninsular War, from 1812 to its Close*, London: Richard Bentley, 1854.
- Long, R., *Peninsular Cavalry General (1811-13): The Correspondence of Lieutenant-General Robert Ballard Long* (McGuffie, T. (ed.)), London: George G. Harrap & Co. Ltd., 1951.
- Mercer, C., *Journal of the Waterloo Campaign*, London: Peter Davies, 1969.
- Milligan, S., *Adolf Hitler: my Part in his Downfall*, Harmondsworth: Penguin Books Ltd., 1972.
- Milligan, S., *Rommel? Gunner Who?: A Confrontation in the Desert* (Hobbs J. (ed.)), Harmondsworth: Penguin Books Ltd., 1976.
- Milligan, S., *Monty: His Part in My Victory* (Hobbs J. (ed.)), Harmondsworth: Penguin Books Ltd., 1978.
- Milligan, S., *Goodbye Soldier*, Harmondsworth: Penguin Books Ltd., 1987.
- Millner, J., *A Compendious Journal of all the Marches, Famous Battles, Sieges, and Other Most Note-Worthy, Heroical, and Ever Memorable Actions of the Triumphant Armies of the Ever-Glorious Confederate High Allies in their Late and Victorious War Against the Powerful Armies of Proud and Lofty France in and on the Confines of Holland, Germany, and Flanders, so far as our Successful British Troops Extended in Conjunction Therein. Digested into Twelve Campaigns, Begun A.D. 1701 and Ended in 1712.*, London: 1733.
- Mills, J., *For King and Country: the Letters and Diaries of John Mills, Coldstream Guards, 1811-1814* (Fletcher, I. (ed.)), Staplehurst: Spellmount Ltd., 1995.

- Morley, S., *Memoirs of a Serjeant of the 5th Regt. of Foot, Containing an Account of his Service in Hanover, South America, and the Peninsula*, Cambridge: Ken Trotman Ltd., 1999.
- Moyle Sherer, G., *Recollections of the Peninsula*, London: Longman, Hurst, Rees, Orme, Brown, and Green, 1824.
- Murray, J., '>Field Surgeon at the Battle of Aliwal: the letters of Dr John Murray during the First Sikh War' (Fraser, J. (ed.)), *Journal of the Society for Army Historical Research*, **LXXII**, 1994, pp. 35-48.
- Oughton, J., *By Dint of Labour and Perseverance: a journal recording two months in northern Germany kept by Lieutenant Colonel James Adolphus Oughton, commanding 1st battalion 37th Regiment of Foot, 1758*, (Wood S. (ed.)) Society for Army Historical Research Special Publication No 14, 1997.
- Pattison, L. F. H., *Personal Recollections of the Waterloo Campaign, in a Series of Letters to his Grand-Children*, Pontefract: Gosling Press, 1992.
- Peebles, J., *John Peebles' American War 1776-1782* (Gruber, I. (ed.)), Stroud: Sutton Publishing Limited for the Army Records Society, 1998.
- Ross-Lewin, H., *With "The Thirty-Second" in the Peninsular and Other Campaigns*, Cambridge: Ken Trotman Ltd, 2000.
- Swabey, W., *Diary of Campaigns in the Peninsular for the Years 1811, 12, and 13* (Whinyates, W. (ed.)), London: Ken Trotman, 1984.
- Shipp, J., *The Path of Glory: Being the Memoirs of the Extraordinary Military Career of John Shipp Written by Himself* (Stranks, C. (ed.)), London: Chatto & Windus, 1969.
- Shipster, J., *Mist on the Rice-Fields: A Soldier's Story of the Burma Campaign and the Korean War*, Barnsley: Leo Cooper, 2000.
- Sliepmann, *Echo of the Guns: Recollections of an Artillery Officer 1914-18*, London: Robert Hale, 1987.
- Smith, E., *Even the Brave Falter*, London: Robert Hale Ltd., 1978.
- Smith, G. L., *A Victorian RSM: From India to the Crimea*, Tunbridge Wells: Costello, 1987.

- Surtees, W., *Twenty-Five Years in the Rifle Brigade*, London: Frederick Muller Ltd., 1973.
- Sweetman, J., >A territorial Subaltern at War, 1917-18', *Journal of the Society for Army Historical Research*, **77**, 1999, pp. 210-217.
- Symonds, R., *The Complete Military Diary* (Peachy, S. (ed.)), Leigh-on-Sea: Partizan Press, 1989.
- Taylor, A., >Letters from the Crimea', *RUSI Journal*, August 1994, pp. 51-60.
- Todd, W., *The Journal of Corporal Todd 1745-1762* (Cormack, A. and Jones, A. (ed.)), Stroud: Sutton Publishing Limited for the Army Records Society, 2001.
- Tomkinson, W., *Diary of a Cavalry Officer in the Peninsular War and Waterloo Campaign 1809-1815*, (Tomkinson, J. (ed.)), London: Frederick Muller Ltd, 1971.
- Travers, H., >The Boer War Diary of Lieutenant Hugh Price Travers' (Travers, T. (ed.)), *Journal of the Society for Army Historical Research*, **79**, 2001, pp. 131-144.
- Vines, S., >VE Day 1945', *Gunner*, September 1995, pp. 65-66.
- Walker, R., >The Boer War Diaries of Lt Col F.C. Mayrick (Part II)', *Journal of the Society for Army Historical Research*, **LXXIII**, 1995, pp. 155-180.
- Waterfield, R., *The Memoirs of Private Waterfield, Soldier in Her Majesty's 32nd Regiment of Foot (Duke of Cornwall's Light Infantry) 1842-57* (Swinson, A. and Scott, D. (ed.)), London: Cassell, 1968.
- Wellesley, E., *Letters of a Victorian Army Officer* (Carver M. (ed.)), Stroud: Alan Sutton Publishing Ltd., 1995.
- Wharton, N., >The Letters of Nehemiah Wharton', S. Peachey (ed.), *The Edgehill Campaign and the Letters of Nehemiah Wharton*, Leigh-on-Sea: Partizan Press, 1997, pp. 5-27.
- Wheatley, E., *The Wheatley Diary: A Journal and Sketchbook Kept During the Peninsular War and the Waterloo Campaign* (Hibbert, C. (ed.)), London: Longmans, 1964.
- Wheeler, W., *The Letters of Private Wheeler 1809-1828* (Liddell Hart, B. (ed.)), Bath: Cedric Chivers Ltd., 1971.
- Wood, J., *Gunner at Large: The Diary of James Wood*, R.A.(Whitworth R. (ed.)), London: Leo Cooper, 1988.

Published Compilations of Primary Sources

- Brander, M. (ed.), *The Sword & The Pen* London: Leo Cooper, 1989.
- Chandler D. (ed.), *Robert Parker and Comte de Merode-Westerloo: The Marlborough Wars*, London: Longmans, 1968.
- Knight, I. (ed.), *Marching to the Drums: Eyewitness Accounts of War from the Kabul Massacre to the Siege of Mafikeng*, London: Greenhill Books, 1999.
- Laffin, J. (ed.), *Letters from the Front 1914-1918*, London: J.M. Dent & Sons Ltd, 1973.
- Lewis, J. (ed.) *The Mammoth Book of War Diaries & Letters: life on the battlefield in the words of the ordinary soldier, 1775 -1991*, London: Robinson, 1998.
- Moore, G. (ed.), *Three Chose War*, Privately published by Geoffrey Moore: 1978.
- Moynihan, M. (ed.), *People at War 1914-1918* Newton Abbot: David & Charles, 1973.
- Palmer, R. (ed.), *The Rambling Soldier: Life in the Lower Ranks, 1750-1900, Through Soldiers' Songs and Writings*, Harmondsworth, Kestrel Books, 1977.
- Young, P. and Tucker, N. (eds.), *Military Memoirs: the Civil War* London: Longmans, Green and Co. Ltd., 1967.

SECONDARY SOURCES

Unpublished Official Documents

- Atherton, R., Weston, K., Wingfield, T., Hampson, A., Kallmeier, V., *The Army Continuous Attitude Survey: Report Five, Main Data Report*, (DERA CHS/MID/CR980158/1.0), Defence Evaluation and Research Agency, August 1988.
- Atherton, R., James, M., Weston, K., Wingfield, T., *The Army Continuous Attitude Survey: Report Three, Main Data Report* (DERA/CHS/HS3/CR 980036/1.0), Defence Evaluation and Research Agency, January 1988.
- Atherton, R., Weston, K., Wingfield, T., Thwaites, S., *The Army Continuous Attitude Survey: Report Twelve, Main Data Report* (DERA/CHS/MID/CR 000248/1.0), Defence Evaluation and Research Agency, May 2000.

- Atherton, R., Weston, K., Hampson, A., Wingfield, T., *The Army Continuous Attitude Survey: Report Six: Main Data Report*, (DERA/CHS/MID/CR980216/1.0), Defence Evaluation and Research Agency, November 1988.
- Atherton, R., Hampson, A., Weston, K. and Kallmeier, V., *The Army Continuous Attitude Survey: Report Four, Main Data Report* (DERA/CHS/MID/CR 980115/1.0), Defence Evaluation and Research Agency, April 1998.
- Brennen, S. D., Weston-Lovelock, K. J. and Morgan, C. A., *Factors Affecting the Recruitment and Retention of Women in the Armed Forces: Obstacles to be Overcome* (DERA/CHS/HS3/WP98006/1.0), Defence Evaluation and Research Agency, 1998.
- Hampson, A. and Lawton, D., *Army Personnel Research Establishment Continuous Attitude Survey (Soldiers) Period Ending 30 June 1992*, MOD: APRE Report 92RO33, 1992.
- James, M., Schmit, V., Weston, K., Price, J., Hampson, A., *The Army Continuous Attitude Survey: Report One, Main Data Report* (DERA/CHS/HS3/CR 97143/1.0), Defence Evaluation and Research Agency, August 1997.
- James, M., Weston, K., Hampson, A., Jarman, J., *The Army Continuous Attitude Survey: Report Two, Main Data Report* (DERA/CHS/HS3/CR 97255/1.0), Defence Evaluation and Research Agency, November 1997.
- Kirke, C., *The Anthropological Analysis of Leadership*, Staff College Project, 1981.
- Kirke, C., *Social Structures in the Combat Arms Units of the British Army*, MOD Defence Fellowship, 17 October 1994.
- Knudson, K., Durand, D. and Stretch, R., *Assessment of the Impact of Pre-Military and Military Trauma on the Physical and Psychological Well-Being of Female and Male Active Duty Soldiers*, Washington DC: Walter Reed Army Institute of Research 20302-5100, 1996.
- Lister, S. G., Bridges, A. P., Kirke, C. M. S., McGuffog, A. and Summers, A., *Corporate Culture and Its Impact on Defence Effectiveness* (QINETIQ/CHS/CAP/CR010521/1.0), QinetiQ Ltd., 2002.
- Lister, S. G., Mortlock, M., Mains-Smith, N. E. and Ellshaw, C. C., *Challenger 2 Commander Performance* (QINETIQ/CHS/CAP/CR/020187/1.0), QinetiQ, 2002.
- MOD, *Army Continuous Attitude Survey Serving Personnel (2), Main Report (draft)* (AG/DAPS Science/TR/8/2002/1.0) dated August 2002.

- MOD, *Army Doctrine Publication Volume 1: Operations*, June 1994.
- MOD, *Army Doctrine Publication Volume 2: Command*, April 1995.
- MOD, *Army Doctrine Publication Volume 3: Soldiering*, February 2000.
- MOD, Directorate of Manning (Army), >The Monthly Manning Report (MMR) (D/DM(A)82/27 dated 4 December 2001)’.
- MOD, Directorate of Manning (Army), >The Monthly Manning Report (MMR) (D/DM(A)82/27 dated 4 February 2002)’.
- MOD, *The Drill Manual, D/DAT/13/28/97*, 1990.
- MOD, *Education for Promotion Level 2*, MOD, 1994.
- MOD, >The Joint Service Systems Approach to Training (JS SAT) Quality Standard’, *Defence Council Instructions, Joint Service*, 85 (1 June 2001), 2001.
- MOD, *Junior Officer Leadership Programme Student Handbook*, March 2001.
- MOD, *The Marilyn Report (D/DM(A)/12/114 MI(A) dated Nov 88)*, 1988.
- MOD, >Notes for Instructors: Leadership Term 2, Notes for Instructors, L30-L58,’ *The Commissioning Course, The Royal Military Academy Sandhurst*, February 1993,
- MOD, > “Operational Task Statements, Appendix to Job Analysis Report (DP&RG Report No 2/01)” ‘, *Review of Officer Career Courses (ROCC) Training Needs Analysis, D/AG/11024/2[DP&RG]*, June 2001.
- Proud, A., *Potential Effects of Army Unit Culture on Implementation of DBL*, Defence Evaluation and Research Agency, 1999.
- Rugg-Gunn, M., McLeod, R., Cunningham, D. and Green, A., *Attitudinal Factors Influencing Military Performance and the Potential for Training Interventions (DERA/CHS/MID/TR01034/1.0)*, Defence Evaluation and Research Agency, 2001.

Published Official Documents

- Bett, M., *Managing People in Tomorrow’s Armed Forces*, HMSO, 1995.
- European Court of Human Rights press release, >Hearings, 23-24 October 2001’, 18 October 2001.

MOD, *The Army List Part III Biographical*, London: HMSO, 1983.

MOD, *Manual of Military Law Part I, 12th Edition*, London: HMSO, 1 May 2001.

MOD, *The Queen's Regulations for The Army 1975 (Including Amendment 24)*, London: HMSO, March 2001.

MOD, Army Briefing Note serial number 25.02, released by DCCA, '>Update on Issues Relating to Deepcut Press Coverage', 7 November 2002.

University Theses and Dissertations

Dendy, S., *The British Garrison in the Siege of Kut-al-Amara, 1915-16: A Study in Morale*, M.A., University of Leeds, 1997.

Hollinger, A., *The Forgotten Army: The British Army System, 1716-1746*, M.A., Emory University (Atlanta, Georgia), 1976.

Irwin, A., *The Social Organization of Soldiering: A Canadian Infantry Company in the Field*, Ph.D., University of Manchester, 2002.

Killworth, P., *Culture and Power in the British Army: hierarchies, Boundaries and Construction*, Ph.D., University of Cambridge, 1997.

Odintz, M., *The British Officer Corps, 1754-1783 (2 vols.)*, Ph.D., University of Michigan, 1988.

Rodley, I., *Leadership Training and Development*, M.Phil, Lancaster University, 1995.

Sheffield, G., *Officer-Man Relations, Morale and Discipline in the British Army 1902-22*, Ph.D., King's College, London, 1994.

Steppler, G., *The Common Soldier in the Reign of George III, 1760-1793*, D. Phil., Oxford University, 1984.

Stevens, C., *The Rifle Brigade 1800 to c. 1870: A Study of Social, Cultural and Religious Attitudes*, Ph.D., University of Sheffield, 1995.

Articles

- Asad, T., >Anthropology and the Analysis of Ideology', *Man (N.S.)*, **14**, 1979, pp. 607-627.
- Boer, P., >Small Unit Cohesion: The Case of Fighter Squadron 3-V1.G.IV', *Armed Forces and Society*, **28**, 2001, pp. 33-54.
- Brumwell, S., >Rank and File: A Profile of One of Wolfe's Regiments', *Journal of the Society for Army Historical Research*, **79**, 2001, pp. 3-24.
- Burke, J., >Army bullies force desertions to a record', *Observer*, 4 June 2000.
- Ellis, J., >Drummers for the Devil? The Black Soldiers of the 29th (Worcestershire) Regiment of Foot, 1759-1843', *Journal of the Society for Army Historical Research*, **80**, 2002, pp. 186-202.
- Field, K. and Nagl, J., >Combat Roles for Women: A Modest Proposal', *Parameters, US Army War College Quarterly*, Summer 2001, 74-88 (www.army.mil/usawc/Parameters/01summer/field.htm).
- Fraser, J., >Europeans Who Sided With the Mutineers in India 1857-9: the Christian bandsmen of the native infantry regiments.', *Journal of the Society for Army Historical Research*, **79**, 2001, pp. 119-130.
- French, C., >The Fashioning of Esprit de Corps in the 51st Highland Division from St Valery to El Alamein', *Journal for Society for Army Historical Research*, **77**, 1999, pp. 275 - 292.
- Gat, A., >Female Participation in War: Bio-Cultural Interactions', *The Journal of Strategic Studies*, **23**, 2000, 21-31.
- Geertz, C., >Form and Variation in Balinese Village Structure', *American Anthropologist*, **61**, 1959, pp. 991-1012.
- Gemmell, I., >Injuries Among Female Army Recruits: A Conflict of Legislation', *Journal of the Royal Society of Medicine*, **2002**, 1998, pp. 23-27.
- Gilbert, A., >Law and Honour Among Eighteenth-Century British Army Officers', *The Historical Journal*, **19**, 1976, pp. 75-87.
- Goldschmidt, W., >A Perspective on Anthropology', *American Anthropologist*, **102**, pp. 789-807, 2000.

- Goodenough, W., >Anthropology in the 20th Century and Beyond', *American Anthropologist*, **104**, pp. 423-440, 2002.
- Greeves, J., >Physical Training of Women in the Military', *Journal of Defence Science*, **6**, 2001, pp. 228-238.
- Hamby, J., >The Mutiny Wagon Wheel: A Leadership Model for Mutiny in Combat', *Armed Forces and Society*, **28**, 2002., pp. 575-600.
- Hannerz, U., >When Culture is Everywhere: Reflections on a Favorite Concept', *Ethnos*, **58**, 1993, pp. 95-111.
- Hussain, A., and Ishaq M., >British Pakistani Muslims' Perceptions of the Armed Forces', *Armed Forces and Society*, **28**, 2002, pp. 601-618.
- Jarvie, I., >The Emergence of British Social Anthropology According to George Stocking', *Philosophy of the Social Sciences*, **31**, 2001, pp. 267-274.
- Kennedy-Pipe, C., >Women and the Military', *The Journal of Strategic Studies*, **23**, 2000, pp. 32-50.
- Killworth, P., >The British Army in Northern Ireland: Internal Security Operations, Training, and the Cease-Fire', *Cambridge Anthropology*, **20**, No. 3, 1998, pp. 1-20.
- Kirke, C., >Social Structures in the Peninsular Army', *RUSI Journal*, Summer 1988, pp. 65-71.
- Kümmel, G., >Complete Access: Women in the Bundeswehr and Male Ambivalence', *Armed Forces and Society*, **28**, 2002, pp. 555-573.
- Latter, E., >The Indian Army in Mesopotamia 1914-18, Part II', *Journal of the Society for Army Historical Research*, **LXXII**, 1995, pp. 160-179.
- Laville, S., and Gregoriadis, L., >Recruits "still ruled by fear at Army base"', *Daily Telegraph*, 18 July 2002
- Lewis, D., >Revealing, Widening, Deepening? A Review of the Existing and Potential Contribution of Anthropological Approaches to "Third Sector" Research.', *Human Organization*, **58**, 1999, pp. 73-81.
- Lieven, M., >A Victorian Genre: Military Memoirs and the Anglo-Zulu War', *Journal of the Society for Army Historical Research*, **77**, 1999, pp. 106-121.

- Lindholm, C., >Logical and Moral Dilemmas of Postmodernism', *Journal of the Royal Anthropological Institute*, **3**, 1997, pp. 747-760.
- Loyal, S., and Barnes, B., >"Agency" as a Red Herring in Social Theory', *Philosophy of the Social Sciences*, **31**, 2001, pp. 507-524.
- Mawton, M. H., > "Not a Very Nice Regiment": Her Majesty's 63rd (The West Suffolk) Regiment of Foot', *Journal of the Society for Army Historical Research*, **LXXVI**, 1998, pp. 73-87.
- McClure, P. and Broughton, W., >Measuring the Cohesion of Military Communities', *Armed Forces and Society*, **26**, 2000, pp. 473-487.
- Mileham, P., >Military Virtues 1: The Right to be Different', *Defense Analysis*, **14**, 1998, pp. 169-190.
- Mileham, P., >Military Virtues 2: The British Army Ethos', *Defense Analysis*, **14**, 1998, pp. 227-246.
- Mitchell, J. >Quantitative Methods and Statistical Reasoning in Social Anthropology' *Sudan Society* **II**, 1963.
- Morill, C., >Conflict Management, Honor, and Organizational Change', *American Journal of Sociology*, **97**, 1991, pp. 585 to 621.
- Norton-Taylor, R., >Army acts as 43% of troops condemn bullying', *Guardian*, 12 November 2002.
- Ortner, S., >Theory in Anthropology Since the Sixties', *Comparative Studies in Society and History*, **26**, 1984, pp. 126-166
- Reid, S., >Captain John Urquhart: a Study in Promotion in the Late Georgian Army', *Journal of the Society for Army Historical Research*, **77**, 1999, pp. 165-171.
- Reid, S., >Who Was the Soldier of the 71st?', *Journal of the Society for Army Historical Research*, **78**, 2000, pp. 138-139.
- Robbins, C., >The "F" Word', *Journal of the Society for Army Historical Research*, **LXXV**, 1997, pp. 270-271
- Rubin, G. R., >The Non-Confirmation of Captain Carey's Court Martial, 1879', *Journal of the Society for Army Historical Research*, **79**, 2001, pp. 219-232.

- Sapsted, D., >Soldier “at point of suicide over bullying”, *Daily Telegraph*, 3 February 2001.
- Shils, E. A. and Janowitz, M., >Cohesion and Disintegration in the Wehrmacht in World War II’, *Public Opinion Quarterly*, **12**, 1948, pp. 280-315.
- Simons, A., >Women Can Never “Belong” in Combat’, *Orbis*, **44**, 2000, pp. 451-461.
- Simons, A., >Women in Combat Units: It’s Still a Bad Idea’, *Parameters, US Army War College Quarterly*, Summer 2001, pp. 89-100 (www.army.mil/usawc/Parameters/01summer/simons.htm).
- Snider, D., >America’s Postmodern Military?’, *World Policy Journal*, Spring 2000, pp. 47-54.
- Sökefeld, M., >Reconsidering Identity’, *Anthropos*, **96**, 2001, pp. 527-544.
- Springett, R., >More of a Man?’, *Contact*, Spring 1999, pp. 8-10.
- Stewart, P., >Complexity Theories, Social Theory, and the Question of Social Complexity’, *Philosophy of the Social Sciences*, **31**, 2001, pp. 323-360.
- Walker, G., >Society and Culture in Sociological and Anthropological Tradition’, *History of the Human Sciences*, **14**, 2001, pp. 30-55.
- Withey, W. R., >Physiological Limits to Human Physical Performance: an Overview’, *Journal of Defence Science*, **6**, 3, 2001, pp. 178-188.

Books and Monographs

- Andreski, S., *Military Organization and Society*, London: Routledge & Kegan Paul Ltd., 1968.
- Anon., *QSR NUD*IST Users Guide*, London: Sage Publications Ltd., 1997.
- Arthur, M., *When this Bloody War is Over: Soldiers’ Songs of the First World War*, London: Piatkus, 2001.
- Banton, M. (ed.), *The Relevance of Models for Social Anthropology* London: Tavistock Publications, 1965.
- Banton, M. (ed.), *The Social Anthropology of Complex Societies*, London: Tavistock Publications, 1968,

- Barker, D., *Soldiering On: an Unofficial Portrait of the British Army*, London: Andre Deutsch, 1981.
- Barnes, J., *Social Networks*, USA: Addison-Wesley Publishing Company Inc, 1972.
- Baynes, J., *Morale: a Study of Men and Courage*, London: Leo Cooper, 1987.
- Baynes, J., *The Soldier in Modern Society*, London: Eyre Methuen, 1972.
- Beattie, J., *Other Cultures: Aims, Methods and Achievements in Social Anthropology*, London: Routledge & Kegan Paul Ltd., 1966.
- Beevor, A., *Inside the British Army*, London: Chatto and Windus, 1990.
- Bellamy, C., *The Evolution of Modern Land Warfare: Theory and Practice*, London: Routledge, 1990.
- Bird, J. (ed.), *Mapping the Futures: Local Cultures, Global Change*, London: Routledge, 1993.
- Bista, D. B., *Fatalism and Development: Nepal's struggle for modernization*, Calcutta: Orient Longman Ltd., 1991.
- Bourdieu, P., *The Logic of Practice* (translated by Nice, R.), Cambridge: Polity Press, 1990.
- Bourdieu, P., *Language and Symbolic Power* (Thompson, J. (ed.), translated by Raymond, G. and Adamson, M.), Cambridge: Polity Press, 1991.
- Brereton, J. M., *The British Soldier: a social history from 1661 to the present day*, London: The Bodley Head, 1986.
- Brumwell, S., *Redcoats: The British Soldier and War in the Americas, 1755-1763*, Cambridge: Cambridge University Press, 2002.
- Bryman, A., and Cramer, D., *Quantitative Data Analysis for Social Scientists*, London: Routledge, 1994.
- Burawoy, M. and Others, *Ethnography Unbound: Power and Resistance in the Modern Metropolis*, Berkeley University of California Press: University of California Press, 1991.
- Calhoun, C., et. al., *Bourdieu: Critical Perspectives*, Cambridge: Polity Press, 1993.

- Chapman, B., *The Science of Society: An Introduction to Sociology*, London: George Allen & Unwin Ltd., 1967.
- Clifford, J. and Marcus, G., *Writing Culture: the Poetics and Politics of Ethnography*, Berkeley: University of California Press, 1986.
- Coates C., and Pellegrin, R. (ed.), *Military Sociology: a Study of American Military Institutions and Military Life*, Maryland: University Park Maryland, Social Science Press 1965.
- Creswell, J. W., *Qualitative Inquiry and Research Design: Choosing among five traditions*, London: Sage Publications Ltd., 1998.
- De Sola Pool, I., *The Social Impact of the Telephone*, Cambridge Mass: MIT Press, 1981.
- Duignan, P. and Gann, L., *Political Correctness: A Critique*, Hoover Institution: Stanford University, 1995.
- Durkheim, E., *The Rules of Sociological Method*, London: Macmillan, 1982.
- Durkheim, E., *Suicide: a study in sociology* (Simpson, G. (ed.)), London: Routledge & Kegan Paul Ltd., 1951.
- Epstein, A. (ed.), *The Craft of Social Anthropology*, London: Tavistock Publications, 1967.
- Feld, M., *The Structure of Violence: armed forces as social systems*, London: Sage Publications, 1977.
- Fielding, J., and Gilbert, G., *Understanding Social Statistics*, London: Sage Publications, 2000.
- Fletcher, I., *In Hell Before Daylight: The Siege and Storming of the Fortress of Badajoz, 16 March to 6 April 1812*, New York: The Baton Press, 1984.
- Fortes, M., (ed.) *Social Structure: Studies Presented to A. A. Radcliffe-Brown*, New York: Russell & Russell Inc, 1963.
- Fraser, D., *And We Shall Shock Them: The British Army in the Second World War*, London,: Hodder and Stoughton, 1983.
- Freud, S., *The Essentials of Psycho-Analysis* (Freud, A. (ed.)), London: Hogarth and the Institute of Psycho-Analysis, 1986.

- Gal, R. and Mengelsdorff, D., *Handbook of Military Psychology*, Chichester: Wiley, 1991.
- Geertz, C., *The Interpretation of Cultures: Selected Essays*, London: Fontana Press, 1993.
- Giddens, A., *The Constitution of Society: Outline of the Theory of Structuration*, Cambridge: Polity Press, 1986.
- Giddens, A. and Turner, J., *Social Theory Today*, Cambridge: Polity Press, 1987.
- Giddens, A., *Modernity and Self-Identity: Self and Society in the Late Modern Age*, Cambridge: Polity Press, 1991.
- Giddens, A., and Person, C., *Conversations with Anthony Giddens*, Cambridge: Polity Press, 1998.
- Giddens, A., and Birdsall, K., *Sociology* (Fourth Edition), Cambridge: Polity Press, 2001.
- Ginzberg, E., *Breakdown and Recovery, Vol 2 of "The Ineffective Soldier: Lessons for Management and the Nation"*, New York: Columbia University Press, 1959.
- Glaser, B., and Strauss, A., *The discovery of Grounded Theory: Strategies for Qualitative Research*, London: Weidenfeld and Nicolson, 1968.
- Goffman, E., *Asylums: Essays on the Social Situation of Mental Patients and Other Inmates*, Harmondsworth: Penguin Books Ltd., 1968.
- Goffman, E., *Encounters*, Harmondsworth: Allen Lane and the Penguin Press, 1972.
- Goffman, E., *Frame Analysis: An Essay on the Organization of Experience*, Harmondsworth: Penguin Books Ltd., 1974.
- Goody, J. (ed.), *The Developmental Cycle in Domestic Groups*, Cambridge: Cambridge University Press, 1971.
- Grenz, S., *A Primer on Postmodernism*, Cambridge: William B. Erdmans Publishing Company, 1996.
- Grimshaw, A. and Hart, K., *Anthropology and the Crisis of Intellectuals*, Cambridge: Prickly Pear Press, 1993.
- Guy, A. J., *Colonel Samuel Bagshawe and the Army of George II, 1731-1762.*, London: The Bodley Head for the Army Records Society, 1990.

- Harvey, D., *The Condition of Postmodernity: An Enquiry into the Origins of Cultural Change*, Oxford: Basil Blackwell, 1980.
- Haythornthwaite, P. J., *The Napoleonic Source Book*, London: Arms and Armour, 1995.
- Hinde, R., and Watson, H., (eds.), *War: A Cruel Necessity? The Bases of Institutional Violence.*, London: Tauris 1995.
- Hockey, J., *Squaddies: Portrait of a Subculture*, Exeter: University of Exeter, 1986.
- Hofstede, G., *Cultures and Organizations: Software of the Mind*, London: HarperCollins, 1994.
- Holmes, E. R., *Firing Line*, Harmondsworth: Penguin Books Ltd., 1987.
- Holmes, E. R., *The Western Front*, London: BBC Worldwide Ltd., 1999.
- Holmes, E. R. (ed.), *The Oxford Companion to Military History*, Oxford: Oxford University Press, 2001.
- Holmes, E. R., *Redcoat: The British Soldier in the Age of Horse and Musket*, London: HarperCollins, 2001.
- Houlding, J., *Fit for Service: The Training of the British Army, 1715-1795*, Oxford: Clarendon Press, 1981.
- Howe, L., *Being Unemployed in Northern Ireland*, Cambridge: Cambridge University Press, 1990.
- Hutcheson, G., and Sofroniou, N., *The Multivariate Social Scientist: Introductory Statistics Using Generalized Linear Methods*, London: Sage Publications, 1999.
- Hutton, J., *Caste in India: its Nature, Function and Origins*, London: Oxford University Press, 1951.
- Jackson, A. (ed.), *Anthropology at Home* London: Tavistock, 1987.
- Janowitz, M., *The Professional Soldier: a social and political portrait*, Glencoe Ill: The Free Press, 1960.
- Janowitz, M., *Sociology and the Military Establishment (revised edition)*, New York: Russell Sage Foundation, revised edition, 1965.

- Jolly, R., *Military Man Family Man: Crown Property*, London: Brassey's Defence Publishers, 1987.
- Jolly, R., *Military Man Family Man: Crown Property*, London: Brassey's (UK), 1992.
- Katzenstein, M., and Reppy, J. (ed.), *Beyond Zero Tolerance: Discrimination in Military Culture*, New York: Roman & Littlefield Publishers, Inc., 1999.
- Kay, P. (ed.), *Explorations in Mathematical Anthropology*, Cambridge, Massachusetts: M.I.T. Press, 1971.
- Klein, M., *Lives People Live: a textbook of transactional analysis*, Chichester: Wiley, 1980.
- Kuper, A., *Anthropologists and Anthropology: the British School 1922-1972*, London: Allen Lane, 1973.
- Kuper, A. (ed.), *The Social Anthropology of Radcliffe-Brown*, London: Routledge and Kegan Paul, 1977.
- Ladurie, E., *Montaillou: Cathars and Catholics in a French Village 1294-1324* (translated by Bray B.), London: Scolar Press, 1978.
- Laffin, J., *Tommy Atkins: the Story of an English Soldier*, London: White Lion Publishers Limited, 1966.
- Lamb, D., *Mutinies: 1917-1920*, London and Oxford: Solidarity, 1977.
- Lawrence, T. E., *Crusader Castles*, London: Golden Cockerel Press, 1936.
- Leach, E., *Lévi-Strauss*, London: Fontana, 1970.
- Leach, E., *Political Systems of Highland Burma: a study of Kachin social structure*, London: The Athlone Press, 1970.
- Levison, D., and Ember, M., *Encyclopedia of Cultural Anthropology*, New York: Henry Holt and Company, 1996.
- Lévi-Strauss, C., *Structural Anthropology* (translated by Jacobson, C., and Schoepf, B.) Harmondsworth: Penguin University Books, 1972.
- Lewis, I. M. (ed.), *History and Social Anthropology* London: Tavistock Publications, 1968.

- Likert, R., *New Patterns in Management International Student Edition*, New York: McGraw-Hill Company, Inc., 1961.
- Lloyd, A., *The War in the Trenches*, London: Book Club Associates, 1976.
- Loomba, N., *Management - a Quantitative Perspective*, London: Collier Macmillan, 1978.
- Lucas, J., *Experiences of War: The British Soldier*, London: Arms and Armour Press, 1989.
- Macdonald, L., *They Called it Passchendaele*, London: Michael Joseph, 1978.
- Macfarlane, A. and Gurung, I., *The Gurungs of Nepal: A Guide to the Gurungs*, Nepal: Ratna Pustak Bhandar, 1990.
- Madrigal, L., *Statistics for Anthropology*, Cambridge: Cambridge University Press, 1998.
- Mair, L., *An Introduction to Social Anthropology*, Oxford: Clarendon Press, 1965.
- Malinowski, B., *Argonauts of the Western Pacific: an account of native enterprise and adventure in the archipelagoes of Melanesian New Guinea*, London: George Routledge & Sons Ltd., 1922.
- McGuffie, T. H., *Rank and File: The Common Soldier at Peace and War 1642-1914*, London: Hutchinson & Co. Ltd., 1964.
- McNeill, W., *The Pursuit of Power: Technology, Armed Force, and Society since A.D. 1000*, Oxford: Basil Blackwell, 1983.
- Merton, R. and Lazarsfeld, P. (ed.), *Studies in the Scope and Method of "The American Soldier"* Glencoe Ill: The Free Press, 1950.
- Mitchel, J. (ed.), *Numerical Techniques in Social Anthropology*, Philadelphia: Institute for the Study of Human Issues, Inc., 1980.
- Moore, G., *Vincent of the 41st*, Huntingdon: privately published by Geoffrey Moore, 1979.
- Moskos, C. and Wood, F., (eds.), *The Military: More than Just a Job?*, London: Pergamon-Brassey's International Defense Publishers Inc, 1988.
- Myatt, F., *British Sieges of the Peninsular War*, London: Guild Publishing, 1987.
- Nettleton, S., and Watson, J., *The Body in Everyday Life*, Cambridge: Routledge, 1998.

- Norris, C., *The Truth About Postmodernism*, Oxford: Blackwell, 1993.
- Ohnuki-Tierney, E. (ed.), *Culture Through Time: Anthropological Approaches*, California: Stanford University Press, 1990.
- Ortner, S., B., *The Sherpas Through their Rituals*, Cambridge: Cambridge University Press, 1978.
- Parker, R., *Men of Dunwich: the Story of a Vanished Town*, London: Collins, 1978.
- Parker, T., *Soldier, Soldier*, London: Heinemann, 1985.
- Parkin, M. and King, D., *Economics (second edition)*, New York: Addison-Wesley Publishers Ltd., 1995.
- Pearsall, J., (ed.), *The New Oxford Dictionary of English*, Oxford: Clarendon Press, 1998.
- Pope, G., *The Biological Bases of Human Behaviour*, London: Allyn and Bacon, 2000.
- Pugh, D., and Hickson, D, *Writers on Organizations (Fourth Edition)*, Harmondsworth: Penguin Books, 1971.
- Rapport, N., *Diverse World-Views in an English Village*, Edinburgh: Edinburgh University Press, 1993.
- Redfield, R., *Human Nature and the Study of Society*, Chicago: University of Chicago Press, 1962.
- Reppy, J. (ed.), *Beyond Zero Tolerance: Discrimination in Military Culture*, New York: Rowman & Littlefield Publishers Inc., 1999.
- Robbins, S., *Organization Theory: Structure, Design, and Applications*, New Jersey: Prentice-Hall International Inc., Third Edition, 1990.
- Rodger, N., *The Wooden World: An Anatomy of the Georgian Navy*, London: Fontana Press, 1988.
- Rookmaaker, H., *Modern Art and the Death of a Culture*, Wheaton Illinois: Crossway Books, 1994.
- Sabean, D., *Property, Production, and Family Life in Neckarhausen, 1700 - 1870*, Cambridge: Cambridge University Press, 1990.

- Sanger, J., *The Compleat Observer? A Field Research Guide to Observation*, London: The Falmer Press, 1996.
- Sarup, M., *An Introductory Guide to Post-structuralism and Postmodernism (Second Edition)*, London: Harvester Wheatsheaf, 1993.
- Scheurich, J., *Research Method in the Postmodern*, London: The Falmer Press, 1997.
- Sharp, J. and Howard, K., *The Management of a Student Research Project, Second Edition*, Aldershot: Gower, 1996.
- Shibutani, T., *The Derelicts of Company K: a Sociological Study of Demoralization*, Berkeley: University of California Press 1978.
- Simpson, W., *Working with Sources: Case Studies in Twentieth-Century History*, Cheltenham: Stanley Thornes (Publishers) Ltd., 1988.
- Smith, T. and Jarkko, L., *National Pride: a Cross-national Analysis*, National Opinion Research Center/University of Chicago GSS Cross-national Report No 19, : May 1998.
- Stewart, N., *Mates and Muchachos: Unit cohesion in the Falklands/Malvinas War*, New York: Brassey's (US) Inc., 1991.
- Stills, D. (ed.), *The International Encyclopaedia of the Social Sciences*, Macmillan and Company & the Free Press, 1968.
- Strachan, H., *European Armies and the Conduct of War*, London: Routledge, 1983.
- Strachan, H., *Wellington's Legacy: The Reform of the British Army 1830-54*, Manchester: Manchester University Press, 1984.
- Strachan, H. (ed.), *The British Army, Manpower and Society into the Twenty-First Century*, London: Frank Cass, 2001.
- Strauss, A., et. al., *Psychiatric Ideologies and Institutions*, London: Transaction Books, 1981.
- Sweet, R., *The English Town, 1680-1840: Government, Society and Culture*, New York: Pearson Education Inc., 1999.
- Tannenbaum, A., *Social Psychology of the Work Organization*, London: Tavistock Publications, 1973.

- Tiger, L., *Men in Groups*, London: Thomas Nelson and Sons Ltd., 1970.
- Trevelyan, G., *England Under the Stuarts (Tenth Edition)*, London: Methuen & Co. Ltd., 1922.
- Trompenaars, F. and Hampden-Turner, C., *Riding the Waves of Culture: Understanding Cultural Diversity in Business*, London: Nicholas Brealey Publishing Ltd., 1997.
- Van Doorn, J. (ed.), *Armed Forces and Society*, The Hague: Moulton, 1968.
- von Zugbach, R., *Power and Prestige in the British Army*, Aldershot: Avebury, 1988.
- Waites, B., *A Class Society at War: England 1914-1918*, Leamington Spa: Berg Publishers Ltd, 1987.
- Wilson, B., *Systems: Concepts, Methodologies, and Applications*, Chichester: John Wiley & Sons, 1990.
- Wilson, B., *Soft Systems Methodology: Conceptual Model Building and its Contribution*, Chichester: John Wiley & Sons Ltd, 2001.
- Winstock, L., *Songs & Music of the Redcoats 1642-1902*, London: Leo Cooper, 1970.
- Winstock, L., *Songs & Marches of the Roundheads & Cavaliers*, London: Leo Cooper, 1971.
- Yardley, M. and Sewell, D., *A New Model Army*, London: WH Allen & Co Plc., 1989.
- Young, M., *An Inside Job: Policing and Police Culture in Britain*, Oxford: Clarendon Press, 1991.