



Ammonia for civil aviation: A design and performance study for aircraft and turbofan engine

Sarath Sasi^{a,*}, Christos Mourouzidis^b, David John Rajendran^c, Ioannis Roumeliotis^d, Vassilios Pachidis^e, Justin Norman^f

^a Rolls-Royce University Technology Centre, Cranfield University, UK

^b Lecturer in Engine-Aircraft Integrated Design, Centre for Propulsion and Thermal Power Engineering, Rolls-Royce University Technology Centre, Cranfield University, UK

^c Lecturer in Aero Systems Design for Future Propulsion Architectures, Centre for Propulsion and Thermal Power Engineering, Rolls-Royce University Technology Centre, Cranfield University, UK

^d Head of Gas Turbine Engineering Group and Reader in Gas Turbine Technology & Thermal Systems Integration, Centre for Propulsion and Thermal Power Engineering, Rolls-Royce University Technology Centre, Cranfield University, UK

^e Head of Centre for Propulsion and Thermal Power Engineering, Centre for Propulsion and Thermal Power Engineering, Rolls-Royce University Technology Centre, Cranfield University, UK

^f Functional Coach – Operability & Controls, Rolls Royce plc, Derby, UK

ARTICLE INFO

Keywords:

Ammonia
Hydrogen
Alternative aviation fuels
Turbofan engines

ABSTRACT

The 2050 net zero targets for aviation to decarbonize the industry means that solutions need to be delivered that can help achieve those targets. Transitioning to zero carbon aviation fuel is an effective solution to achieve those targets. This research article aims to highlight the potential design and performance implications of using Ammonia as a zero-carbon fuel for civil aviation through a retrofit case study conducted for an Airbus A350-1000 equivalent aircraft. The impacts on both turbofan design and aircraft payload-range capability are presented. A feasibility study of using Ammonia as a Hydrogen carrier for civil aviation is also presented. The turbofan design impacts, and payload range capability are assessed using Cranfield University's in-house gas turbine performance tool TURBOMATCH and NASA FLOPS respectively. A 3-point turbofan cycle design strategy is utilized for redesigning turbofan engine cycles using Ammonia as a fuel. Ammonia fuel conditioning assessment is made using REFPROP to investigate its impact on turbofan design. Utilizing pure Ammonia as an aircraft fuel can provide significant turbofan redesign opportunities. Fuel conditioning assessment revealed that for a 430 kN thrust class engine, 2.1 MW of thermal power is required to condition Ammonia fuel at take-off. As a result, various strategies to condition the fuel and its significant impact on turbofan design are presented indicating fuel conditioning as a major design driver for Ammonia fuelled turbofan engines in the future. Although upon initial preliminary assessment, Ammonia utilized as a Hydrogen carrier showcased potential by providing additional mission range capability when compared to a pure Ammonia burning aircraft, the significant thermal energy required to crack (decompose) Ammonia into Hydrogen highlighted the challenges at aircraft mission level and Hydrogen turbofan design implications. It is found that energy requirement (power) to crack Ammonia into Hydrogen are significant which is approximately an order of magnitude higher than Ammonia fuel conditioning itself.

1. Introduction

Recent announcements from ICAO (International Civil Aviation Organization) voting for net zero aviation by 2050 [1] showcases the

efforts made to decarbonize aviation industry in order to keep the global temperature rise within 1.5 °C in accordance with Paris Agreement. In 2021, IATA announced their plans to achieve net zero by 2050 to respect the same. Solutions need to be identified that can help achieve these

* Corresponding author.

E-mail addresses: sarath.sasi@cranfield.ac.uk (S. Sasi), c.mourouzidis@cranfield.ac.uk (C. Mourouzidis), d.rajendran@cranfield.ac.uk (D.J. Rajendran), i.roumeliotis@cranfield.ac.uk (I. Roumeliotis), v.pachidis@cranfield.ac.uk (V. Pachidis), justin.norman@rolls-royce.com (J. Norman).

<https://doi.org/10.1016/j.enconman.2024.118294>

Received 8 December 2023; Received in revised form 26 February 2024; Accepted 7 March 2024

Available online 6 April 2024

0196-8904/© 2024 The Author(s). Published by Elsevier Ltd. This is an open access article under the CC BY-NC-ND license (<http://creativecommons.org/licenses/by-nc-nd/4.0/>).

targets to decarbonize aviation industry. Currently, as per the ASTM standards [2], blending synthetic aviation fuels from 10 % to 50 % with Jet-A is allowed. Up to 80 % reduction in life cycle carbon emissions is expected with the use of sustainable aviation fuels [3,4]. However, it still produces inflight emissions as this fuel is still a hydrocarbon with the additional challenge of scaling its production up in a sustainable manner. One of the solutions to negate the inflight emissions is to switch to zero carbon fuels. Ammonia is one such zero carbon fuel.

Kailos [5] investigated Ammonia for the US Army in the 1960's with its application limited to helicopter and propeller driven aircraft. The study was mainly motivated by fuel supply logistic reasons and not environmental. The study concluded that Ammonia was not a favorable candidate for military applications due to the significant limitations in the payload carrying capability. Newhall and Starkman [6] investigated Ammonia as gas turbine fuel theoretically and proved that Ammonia powered gas turbine can provide very high thermal efficiencies that is up to 10 % or higher than a gas turbine powered by a hydrocarbon fuel. Verkamp et al [7] states that neat Ammonia suffers from limited flame stability in gas turbine burners and pre-cracking or partial dissociation enables proper usage of Ammonia as a gas turbine fuel. Pratt [8] also reports similar findings about the challenges of burning Ammonia in gas turbine combustors mainly attributable to the slow chemical reaction kinetics which leads to flame blowouts. A military hypersonic research aircraft, X-15, was powered by a rocket engine using anhydrous Ammonia and liquid Oxygen as fuel in the 1950 s [9]. Studies where Ammonia is combusted with more reactive fuels such as Kerosene and Methane in micro gas turbines are reported by Iki et al [10] and Kurata et al [11]. Goldman et al [12] investigated electrofuels for aviation. The study reports that using alternative fuels leads to an increase in power output from gas turbines. This conclusion was based on an investigation of a single turbine operating point. The study also suggests cracking Ammonia into a mixture of Ammonia and Hydrogen before injection into the combustion chamber as this can enhance the low reactivity of Ammonia to allow stable burning in the combustion chambers. Reaction Engines [13] completed a proof of concept study that uses Ammonia as fuel for aircraft. Some Ammonia is cracked into Hydrogen and Nitrogen using heat exchangers and catalysts after which the fuel mix (Ammonia and Hydrogen) is then fed into the combustion chamber. Raytheon Technologies [14] discusses the application of Ammonia as aircraft fuel where it is cracked into Hydrogen and fed into combustion chambers. They are also investigating Ammonia as a fuel for electrified aviation applications through their ZAPTurbo program [15]. Mashruk et al [16] investigated experimentally, combustion of Ammonia and Hydrogen mixture in the ratio of 70/30 NH₃/H₂ blend by volume percentage. It reported adding 30 % H₂ by vol increases the flame speed compared to pure Ammonia flames. Aviation H2, an Australian company is aiming to test liquid Ammonia for a Falcon-50 bizjet [17]. It aims to crack Ammonia partially into Hydrogen and Ammonia with the help of a cracking unit using energy from the exhaust and burn in the combustion chambers. Otto et al [18] assessed Ammonia as an aircraft fuel for a Boeing B737-8 variant aircraft. Ammonia is carried in liquid state in the wings. The liquid Ammonia is used as a heat sink to enable system wide performance improvements. Since it is stored at 239 K, it is used for intercooling and bleed air cooling. The cracking unit converts gaseous Ammonia into Hydrogen before it is fed into combustion chamber. Phillip [19] reviews different sustainable energy carriers for aviation that includes synthetic kerosene, Hydrogen, Ammonia, Natural Gas, Alcohols and battery. However, it is reported that Ammonia is not a viable sustainable energy carrier for aviation citing low specific energy, high toxicity and corrosive qualities as reasons which result in poor aircraft performance and challenging fuel handling qualities. Sasi et al [20] assessed the impacts of alternative aviation fuels on aircraft and engine. However, in the case of Ammonia fuel, the study does not assess the impact of Ammonia on engine size and weight, impact of fuel conditioning requirements on engine design and Ammonia's role as a Hydrogen carrier for civil aviation.

Table 1 provides the physical and chemical properties of Ammonia and Hydrogen.

These recent studies and activities show the increasing interest and relevance of Ammonia as a carbon free fuel for aviation. In the studies mentioned above, there exist gaps that demand further assessments. There is no assessment of the payload-range capability of the Ammonia powered aircraft for civil aviation. The turbofan design and performance implications when operating with Ammonia fuel are not assessed or quantified. It's impact on turbofan engine size and weight is not assessed. The fuel conditioning requirements in terms of thermal power and its impact on turbofan design is not explored. The implications of using Ammonia as a Hydrogen carrier for aviation are missing. The aim of this research article is to address these gaps, explore and quantify the impacts that can potentially influence the future research and development of first-generation Ammonia powered aircraft and turbofan engine.

2. Methodology

To investigate the research gaps, a methodology based on Cranfield University's EPIDOSYS (Engine Preliminary Integrated Design Optimisation SYSTEM) platform is utilized as shown in Fig. 1.

Ammonia and Hydrogen fuel is integrated into TURBOMATCH [24] for the assessment. The thermofluid models of these fuels that is required for the performance assessment of gas turbines are based on the stoichiometric combustion data with air [23]. No combustion dissociation effects are considered. ATLAS [25] is a gas turbine size and weight estimation software from Cranfield University. It has been adapted to accommodate alternative fuels through the fuel properties obtained from NASA CEA (Chemical Equilibrium with Applications). CEA [26] is a software that is able to calculate thermodynamic and transport properties of combustion products in chemical equilibrium with each other. In order to assess the payload-range capability, NASA FLOPS (Flight Optimisation System) [27] is used. It is a multidisciplinary aircraft preliminary design and analysis package developed by the NASA Langley Research Centre. The flight assessment reported in this study considers the fuel storage implications. Gravimetric index [28] is used to quantify storage implications which is defined as:

$$\eta_{grav} = \frac{M_f}{M_f + M_t} \quad (1)$$

where:

η_{grav} – Gravimetric tank efficiency/Gravimetric index (GI).

M_f – Mass of fuel.

M_t – Mass of tank.

Liquid Ammonia is assumed to be stored at 239 K in the wings as in [18]. The GI parameter helps to quantify/impose the weights of insulation needed for Ammonia fuel on the aircraft. A value of 97 % is assumed in this study as Ammonia is a relatively high boiling point fuel with lower insulation requirements in contrast to cryogenic fuels like Liquid Hydrogen. A 3-point turbofan cycle design strategy that includes fuel conditioning requirements is utilized to design the turbofan cycles with the process flowchart shown in Fig. 2. The decision variables and the constraints are given in Table 2.

Table 1

Physical and chemical properties of Ammonia and Hydrogen [12,21–23]; Note: * denotes at boiling point.

Properties	Ammonia	Hydrogen
*Density (kg/m ³)	684	71.4
*Boiling Point (K)	239.1	21
Molecular Weight (g/mol)	17	2
Lower Heating Value (MJ/kg)	18.61	120
*Specific Heat Capacity (kJ/kg.K)	4.6	8.68
Autoignition Temperature (K)	630	560

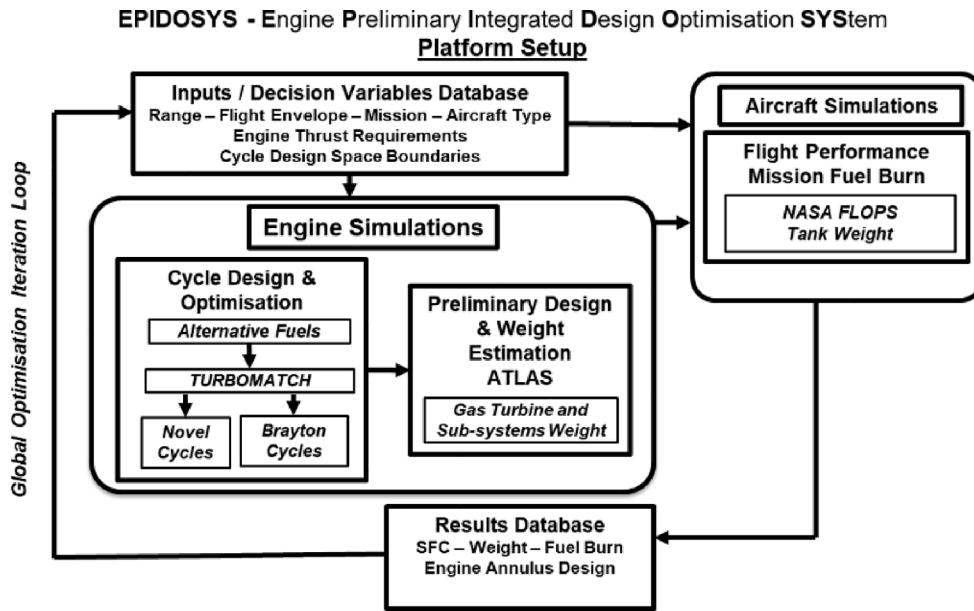

Fig. 1. Cranfield University's EPIDOSYS Platform based methodology.

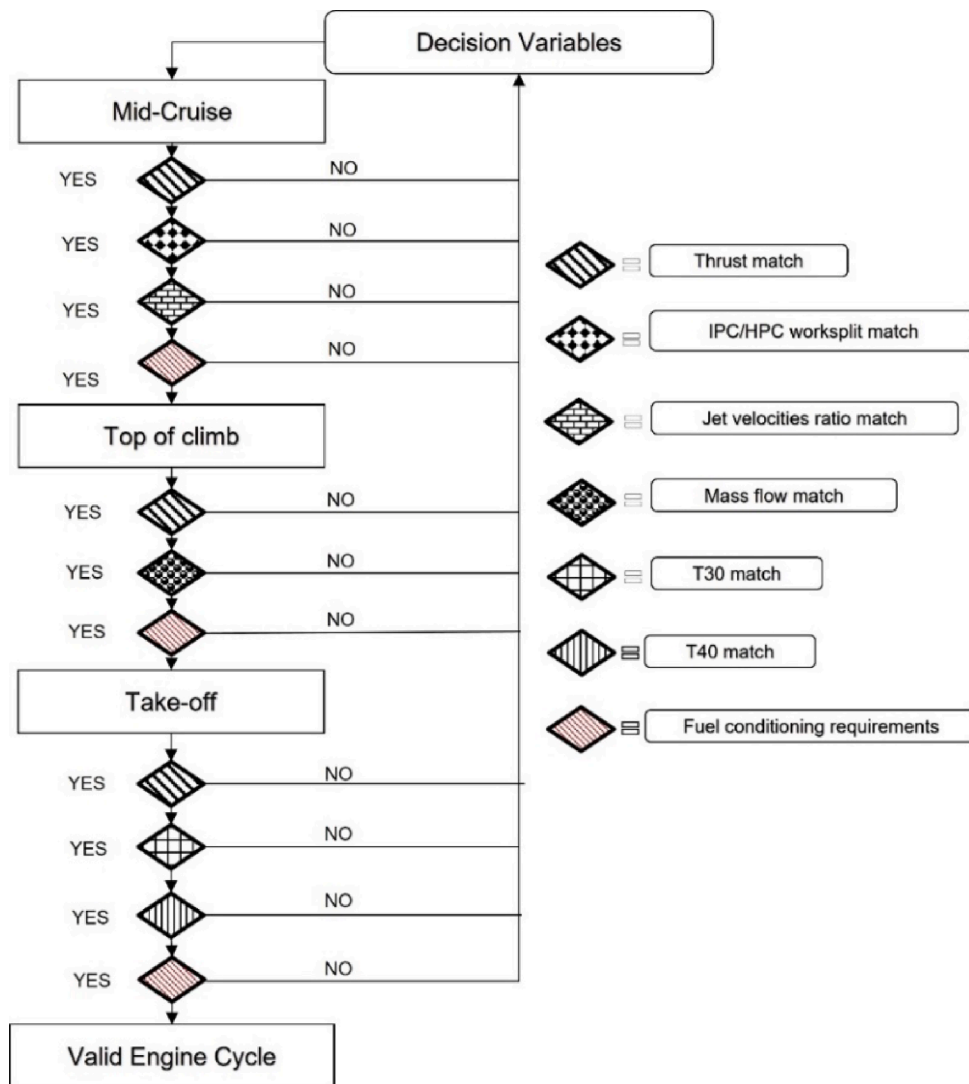

Fig. 2. 3-point turbofan cycle design strategy with fuel conditioning process flowchart.

Table 2
Decision variables and constraints for cycle design.

Decision Variables	Constraints
Mid-cruise T40	Take-off T40
IPC PR	Take-off T30
HPC PR	IPC/HPC PR split
Fan Tip PR	TOC Massflow
Mid-Cruise BPR	Jet Velocities Ratio
Delta T/Power Off-takes	Fuel Heating Power

In this study, 3-point cycle design is performed for the same take-off T40's as the baseline kerosene turbofan engine cycle to have identical peak cycle temperatures, same take-off T30's as the baseline to have identical HPC blade exit temperatures, same core compressor pressure ratio split as the baseline, same fan size (diameter) as the baseline and a range of jet velocities ratios (bypass nozzle cold velocity to core nozzle hot velocity) to minimize the specific fuel consumption while respecting the above constraints. The fuel conditioning requirement (heating power) is calculated using REFPROP [29]. The maximum hot and cold section temperatures along with the turbomachinery component efficiencies are presented in Table 3. The turbomachinery component efficiencies have been assumed to be of year 2020 based on Sebastian et al [30].

2.1. Aircraft and turbofan engine model

An Airbus A350-1000 equivalent model is developed with the help of NASA Flops and TURBOMATCH using the data from [31] with characteristics of the modelled aircraft shown in Table 4.

This paper deals with the application of a 3-spool turbofan engine architecture. A 3-spool high bypass ratio turbofan engine is modelled as presented in Fig. 3.

The 3-spool turbofan model consists of a single stage fan, an 8 stage intermediate pressure compressor, a 6 stage high pressure compressor, an annular combustor, a single stage high pressure turbine, a 2 stage intermediate pressure turbine, a 6 stage low pressure turbine and 2 nozzles (bypass and core) since it is an unmixed separate exhaust system.

The modelled kerosene turbofan performance data for 3 points namely MCR, MCL and MTO are presented in Table 5.

The integrated kerosene powered aircraft and engine model is validated with the help of a payload-range diagram comparison with the data obtained from [31]. The comparison is presented in Fig. 4.

The error of the model between 3 points namely max-payload, max-fuel and ferry range compared to Public Data are within 2–3 %. With regards to the aim of the study, which is to compare at a top level, the impacts of Ammonia fuel, this margin is deemed to be satisfactory.

3. Results and discussion

3.1. Aircraft and turbofan engine for Ammonia

Ammonia aircraft is modelled with the support of gravimetric index

Table 3
Cycle temperatures and efficiencies for the modelled turbofan engines.

Variables	Value
T40 (K)	1912
T30 (K)	963
$\eta_{poly,Fan}$	0.948
$\eta_{poly,IPC}$	0.917
$\eta_{poly,HPC}$	0.921
$\eta_{poly,HPT}$	0.893
$\eta_{poly,IPT}$	0.898
$\eta_{poly,LPT}$	0.924

Table 4
Aircraft model top level design specifications.

Performance	Value
MTOW (kg)	316,000
PAX	369
Design Range (nm)	8077
Max Fuel (kg)	122,500
No of Engines	2
Cruise Altitude (m)	10,668
Cruise Mach	0.85

correlations to consider the fuel storage implications on aircraft performance. The study is a retrofit exercise meaning no visible changes to the airframe is made to maintain the same drag polar of the aircraft and hence, the fan size of the turbofan engine is kept the same. This is modelled for the design PAX of 369 while respecting MTOW. A payload range diagram shows the mission capability of an Ammonia fuelled aircraft compared to the baseline kerosene variant. It should be noted that the MTOW is respected to be within the structural limitations of the aircraft. The payload range diagram comparing Ammonia powered and kerosene powered A350-1000 equivalent aircraft for 369 PAX is presented in Fig. 5.

The lower heating value of Ammonia is 18.61 MJ/kg whereas kerosene/Jet-A is 43.12 MJ/kg. The impact of LHV on aircraft performance is clearly visible from Fig. 5 by the reduction in range. This can be explained by Breguet range equation [32] below:

$$Range = \frac{LHV}{g} * \eta_{overall} * \frac{L}{D} * \ln\left(\frac{W_i}{W_f}\right) \quad (2)$$

where:

$\eta_{overall}$ – Overall Efficiency.

$\frac{L}{D}$ – Aerodynamic Efficiency.

g – acceleration due to gravity.

W_i – Initial weight.

W_f – Final weight.

Range is directly proportional to the LHV of the fuel. Another notable feature is that MTOW line is steeper for Ammonia compared to kerosene. This shows the less energetic nature of Ammonia. This highlights that any change in weights due to future technological breakthroughs will have a lower impact on Ammonia aircraft compared to the kerosene counterpart.

The top-level aircraft comparison for design PAX between Ammonia and kerosene powered variants is presented in Table 6.

From Table 6, the main points for the Ammonia aircraft to be noted are as follows:

- Block energy consumption per pax.nm is reduced by 3.1 %
- Water emissions per pax.nm are increased by 2.95 times
- Global warming potential considering the emitted CO₂ and H₂O, Ammonia reduces the global warming impact by 75 %
- Range reduced by 56.2 %

The GWP (Global Warming Potential) has been defined in the following manner:

$$GWP = \frac{\text{radiative forcing of 1kg of pollutant}}{\text{radiative forcing of 1kg of CO}_2} \quad (3)$$

The equivalent CO₂ when accounting for water vapor emissions is obtained using the formula in (4).

$$\frac{CO2eq}{pax.nm} = \frac{CO2}{pax.nm} + (GWP * \frac{H2O}{pax.nm}) \quad (4)$$

GWP value for water vapor at 10,668 m is assumed to be 0.29 from data reported by Khandelwal et al [33]. Water vapor causes global warming

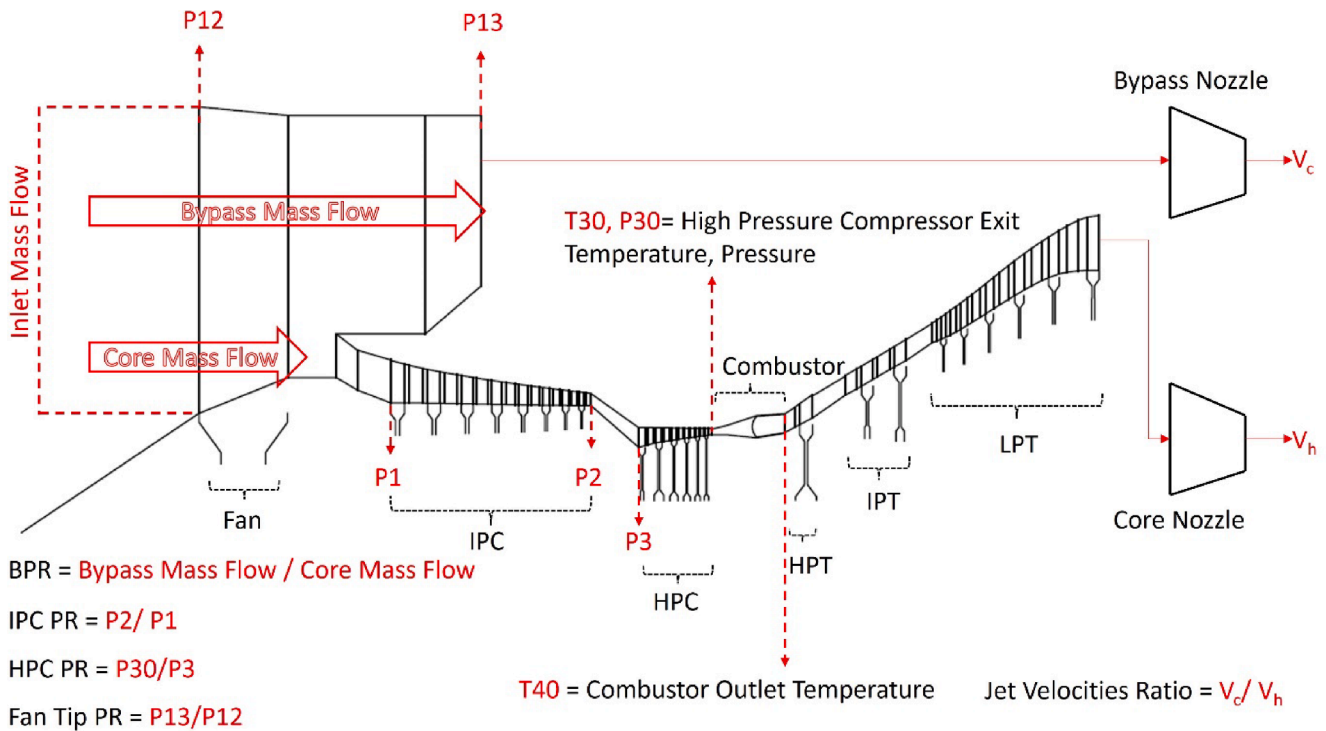

Fig. 3. Schematic of a 3-spool turbofan engine.

Table 5
Performance of modelled turbofan.

	MCR	MCL	MTO
ISA dT	0	+ 10	+ 15
Mach No	0.85	0.85	0.25
Altitude (m)	10,668	10,668	0
FN (N)	64,630	84,000	345,100
BPR	9.6	8.7	8.9
T40 (K)	1500	1704.4	1912.3
OPR	41.1	50	47
Sp.Thrust (N.s/kg)	119.52	148.17	244.76
SFC (g/kN.s)	13.99	14.84	10.22

effect from 10 km altitude onwards and hence the effects of water vapor are considered only for the cruise segment. The effects of contrails are not considered in this study. CO₂ and H₂O emissions are calculated based on stoichiometric relations for kerosene and Ammonia combustion without any dissociation. The turbofan engine cycle design and performance comparison are presented in Table 7. All performance parameters are at design point MCR unless explicitly stated.

Table 7 shows the turbofan design and performance impacts when operating with Ammonia fuel. The fuel injection temperature of both kerosene and Ammonia has been assumed to be 300 K. It is found that when the turbofan cycle is redesigned using Ammonia as a fuel for the same fan size, take-off T40 and take-off T30, a turbofan engine is envisaged with a smaller core size or in other words, a higher BPR as is

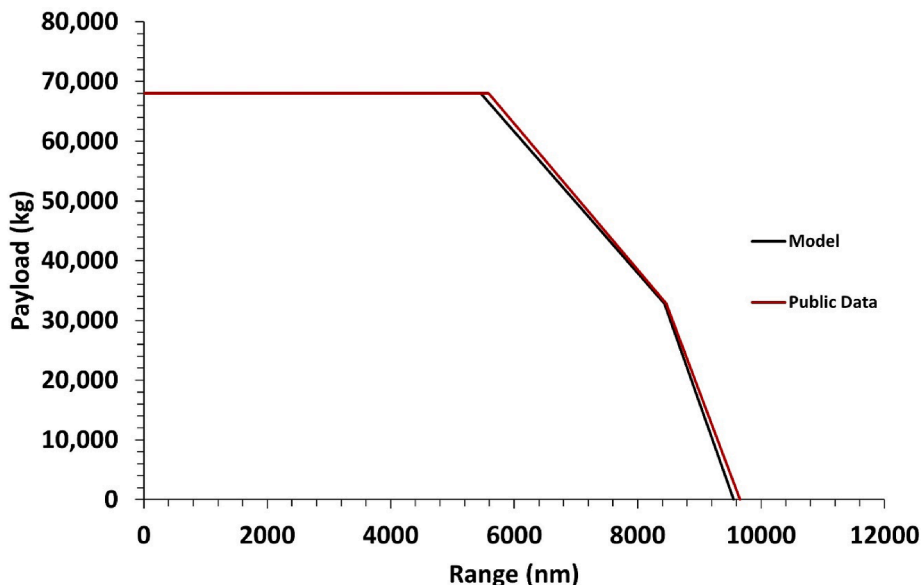

Fig. 4. Airbus A350-1000 payload range validation.

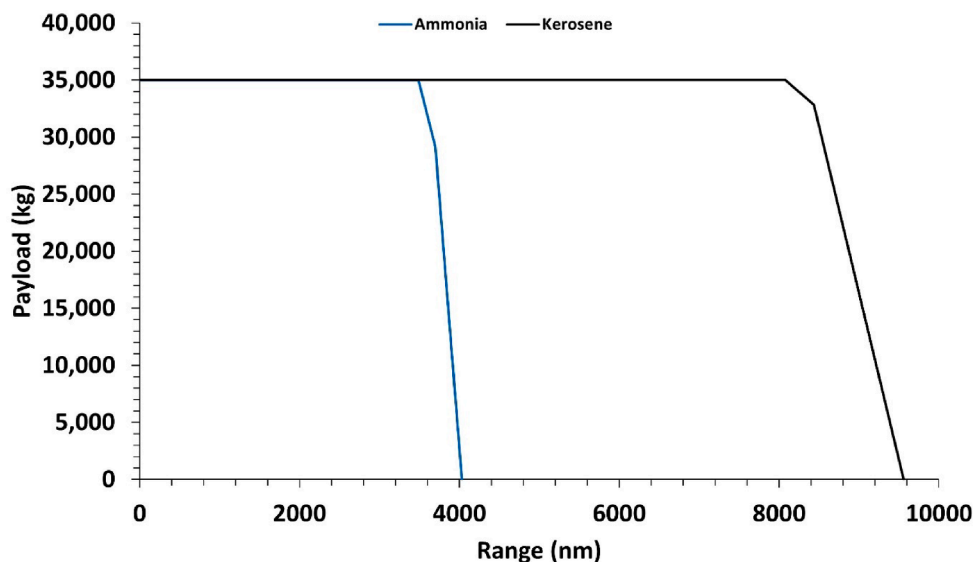

Fig. 5. Payload range comparison.

Table 6

Top level aircraft performance comparison between kerosene and Ammonia powered variants.

	Kerosene	Ammonia	Units
MTOW	316,000	316,000	kg
OEW	159,000	161,000	kg
PAYLOAD	35,000	35,000	kg
FUEL	122,000	120,000	kg
Range	8077	3538	nm
Block Energy	1.61	1.56	MJ/pax.nm
CO ₂ /pax.nm	0.113		kg/pax.nm
H ₂ O/pax.nm	0.045	0.133	kg/pax.nm
CO ₂ eq/pax.nm	0.125	0.032	kg/pax.nm

Table 7

Turbofan cycle design and performance comparison.

	Kerosene	Ammonia
BPR	9.6	13.0
ESFC (J/N. s)	603.4	566.0
SFC (g/kN. s)	13.99	30.42
T40 (K)	1500.0	1549.8
OPR	41.1	40.8
Sp.Thrust (N.s/kg)	119.52	118.55
MCR FN (N)	64,630	64,100
MCL FN (N)	84,000	83,300
MTO FN (N)	345,100	345,100
Fan Diameter (m)	3	3
MTO T40 (K)	1912	1912
MTO T30 (K)	963	963

presented. ESFC (energy specific fuel consumption) is a measure of overall efficiency of the turbofan engine in terms of energy consumed. It shows that Ammonia provides higher overall efficiencies. In this case, a 6 % ESFC benefit is obtained. The higher potential working fluid entering the hot core section after combusting Ammonia fuel is the reason behind significant turbofan redesign capability and energy efficiency compared to kerosene engine.

Preliminary engine annulus diagram has been generated using ATLAS and is presented in Fig. 6.

The blade geometrical non dimensional parameters (space to chord ratios and aspect ratios) were kept the same for generating the annulus diagram. The impact of smaller core size on length of the engine is observed. A 9.37 % reduction in engine weight compared to kerosene

engine is obtained for the Ammonia turbofan engine mainly due to reduction in core size.

As Ammonia is a nitrogen hydride, it is a fuel that has a nitrogen in it. Fuel NO_x (nitrogen oxide) emissions could be produced when burning Ammonia in addition to thermal NO_x due to atmospheric nitrogen. However, the adiabatic flame temperature of Ammonia is lower than hydrocarbons and this could lead to lower thermal NO_x emissions. The laminar flame speeds are low since Ammonia is a low reactive fuel leading to challenges in stabilizing the flame in the burners. Even though Ammonia being a gas that is lighter than air, its toxicity warrants precautionary measures while handling to avoid any safety hazards based on the details outlined in a study [34]. It reports an OSHA (Occupational Health and Safety Administration) exposure limit of 50 ppm with further exposure having different health impacts.

3.2. Fuel conditioning assessment

A fuel conditioning assessment is conducted to investigate its impact on turbofan engine design. The tank conditions for Ammonia fuel are assumed to be 1 atm and 239 K while the combustor injection conditions are said to be 25 % more than HPC P30 and 300 K to ensure stable combustion. In Fig. 7, the phase of Ammonia is represented in a pressure vs enthalpy diagram for the Ammonia turbofan engine represented in the previous section (Table 7).

From Fig. 7, it is observed that for the 3 operating conditions investigated namely MCR, MCL and MTO, Ammonia exists as a sub-cooled liquid. This indicates handling conditions to be favourable when considering the fuel management system. However, there could be possibilities of cavitation occurring as these points are close to the vapor dome. The thermal power for fuel conditioning is evaluated and presented in Table 8.

In this assessment, 3 point thrust requirements for Ammonia fuelled turbofan engines are kept same as mentioned previously in Table 7. The reason behind this is to assess the impact of fuel conditioning on the turbofan design while delivering the same thrust. The strategies investigated to condition the fuel using the turbofan engines as an energy/power source are electric heating, preheater, intercooling, bleed air heating and exhaust gas heating. For strategies where heat exchangers are needed, a total pressure loss in the flowpath is assumed due to the operation of heat exchanger. This will be for intercooling, exhaust gas heating and bleed air heating.

A brief description of the fuel conditioning strategy is presented in the following subsections and then finally the cycle design results are

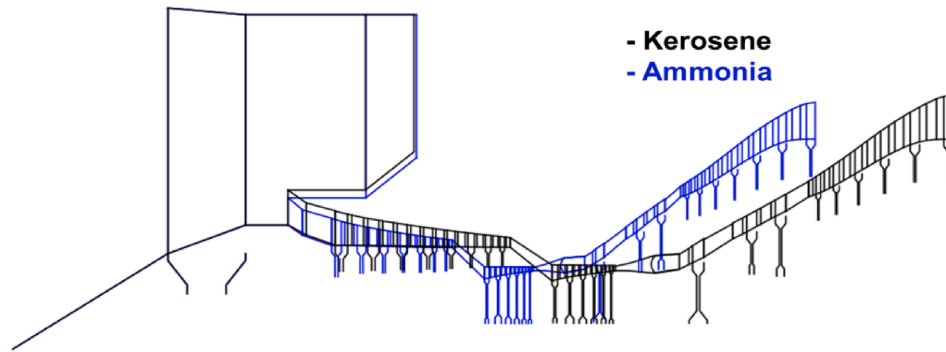

Fig. 6. Turbofan engine annulus diagram.

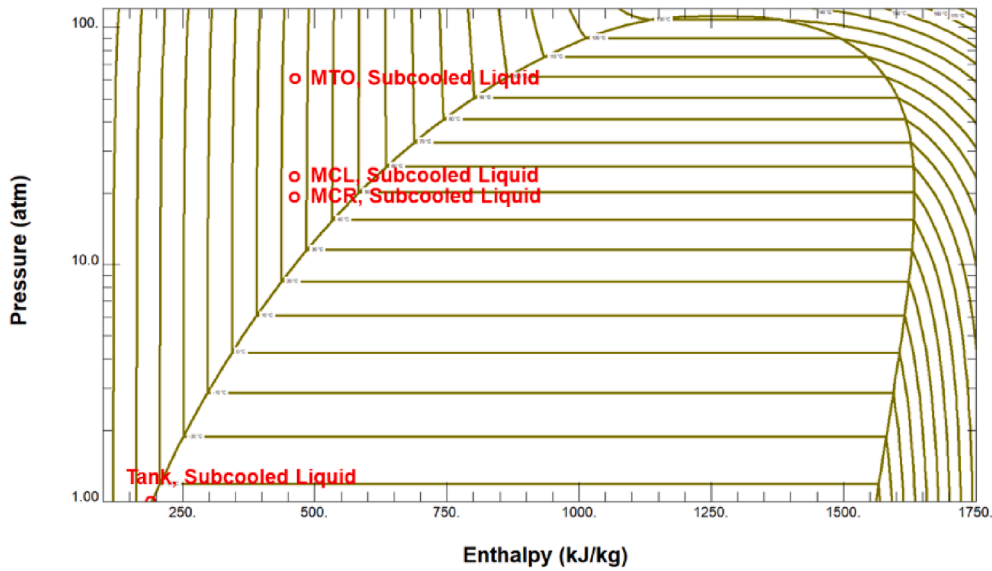

Fig. 7. Ammonia Phase in MCR, MCL, MTO and Tank conditions.

Table 8
Ammonia fuel conditioning requirements in terms of thermal power.

	MCR	MCL	MTO	Units
Fuel Flows	1.95	2.70	7.62	kg/s
dh (Injection - Tank)	271,840	272,020	273,680	J/kg
Thermal Power	529,890	734,040	2085,470	W

discussed.

3.2.1. Electric heating

In this strategy, an electric heater is considered to be drawing power from the high pressure turbine. The power transfer line for such a system is envisaged with a gearbox connected to an electric heater via a generator. The pump is assumed to draw fuel from the tanks and pressurise it to the required pressures where the electric heater will heat it to the required injection temperature before entry into the combustor. The fuel conditioning requirement (heating power) is extracted from the HPT and in this way, the impact on the engine cycle can be assessed. The envisaged schematic of such a system for a 3 spool architecture is showcased in Fig. 8.

3.2.2. Preheating with bleed air

In this strategy, an external preheater system is assumed to be installed on the aircraft at an appropriate location. An additional combustor will burn Ammonia fuel with the air that is bled between IPC

and HPC. The combustion is assumed to be stoichiometric for this assessment. A heat exchanger will transfer the energy released from combustion to preheat Ammonia. The bleeding of air from the engine will impact the cycle performance and design. The envisaged schematic of such a system for a 3 spool architecture is showcased in Fig. 9.

3.2.3. Intercooling

In this strategy, a heat exchanger is assumed to be installed between IPC and HPC. Heat from the cold end of the engine is used to condition Ammonia from 239 K to 300 K. In this process, the temperature levels of the compressor air drop leading to reduction in HPC work and blade exit temperatures. However, in this assessment, the engine cycle is redesigned to maintain the same level of HPC blade exit temperatures at take-off as the baseline kerosene engine cycle. A 4 % total pressure loss in the flowpath is assumed due to the operation of a heat exchanger.

The pressurised fuel is passed through the heat exchanger that is situated between the IPC and the HPC to heat Ammonia before injection into the combustion chamber. The schematic of such a system for a 3-spool engine architecture is showcased in Fig. 10.

3.2.4. Bleed air heating

In this strategy, hot air that is bled after the HPC to cool the HPT NGV blades is used to provide energy to condition the fuel with a heat exchanger. This allows reduction of cooling flows since the air entering the NGV stream is now colder and more effective in cooling the blades. This is expected to impact the cycle design. The fuel is drawn from the

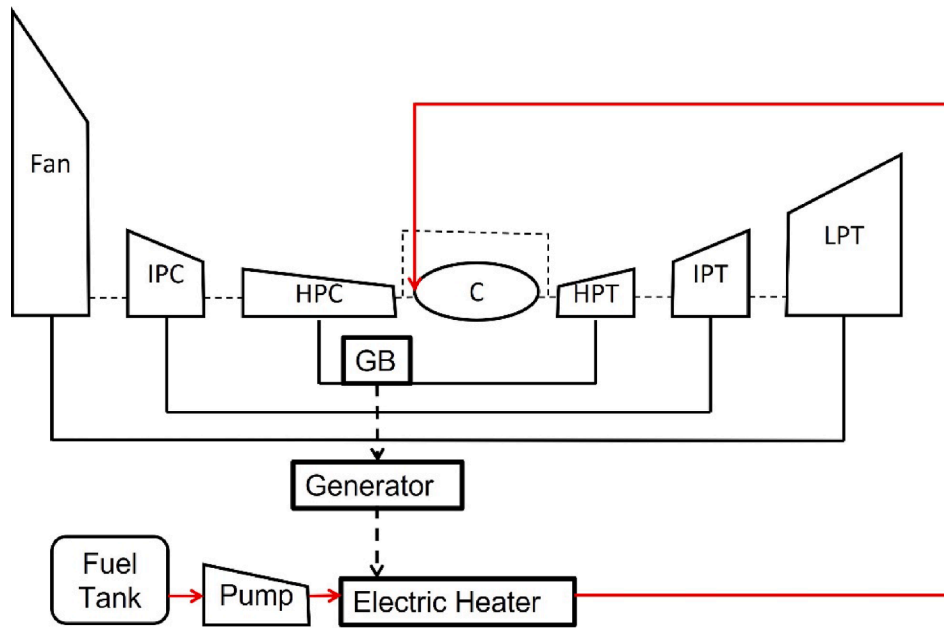

Fig. 8. Schematic of an electric heating fuel conditioning setup on a 3-spool engine architecture.

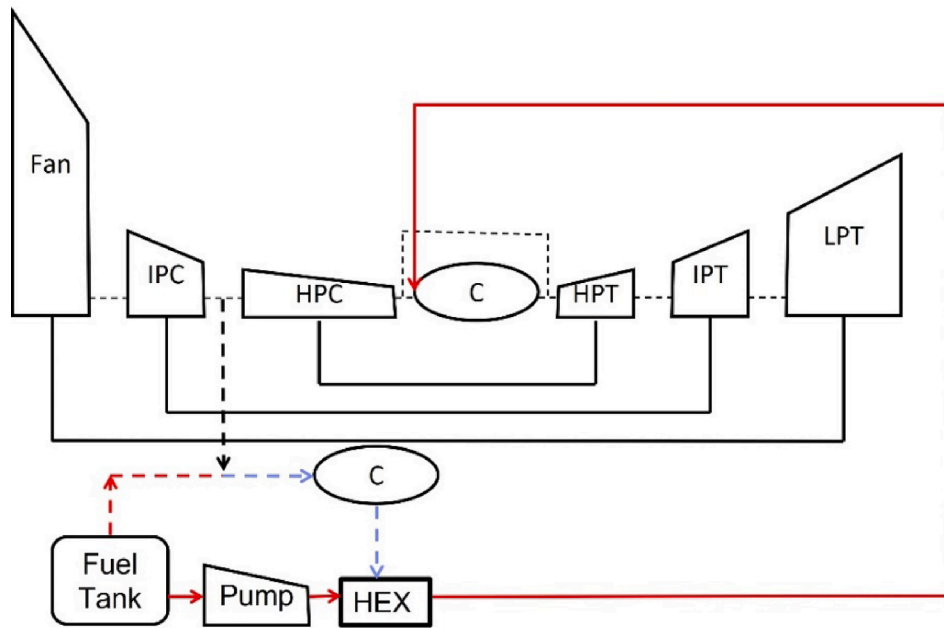

Fig. 9. Schematic of a preheater fuel conditioning setup on a 3-spool engine architecture.

tanks, pressurised using the pumps and heated up to the required temperature using a heat exchanger. The schematic of such a system for a 3-spool engine architecture is showcased in Fig. 11.

3.2.5. Exhaust heating

In this strategy, the exhaust gases exiting the LPT is utilized to provide energy to condition the fuel. A 4 % total pressure drop in the flowpath is assumed due to the operation of the heat exchanger.

Extracting energy from the core stream after the LPT will impact the cycle performance due to the total pressure and temperature loss. The fuel is drawn from the tank and pressurised using the pump after which the heat exchanger increases the temperature of Ammonia. The schematic of such a system for a 3-spool architecture is showcased in Fig. 12.

3.2.6. Impact of Ammonia conditioning on turbofan design and performance

Cycle design is performed using the 3-point design strategy for the same fan size, same take-off T40 and T30 as the baseline kerosene engine cycle. The cycles are compared to case where fuel conditioning is not utilized (no fuel conditioning). Fig. 13 presents the top-level impacts at design point MCR when fuel conditioning is performed using the engine as the energy/power source. Table 9 presents the MCR T40 and OPR differences in absolute degree kelvin and percentages respectively. Table 10 presents the 3-point thermal power requirements to condition the fuel according to the fuel conditioning strategy assessed.

From Fig. 13, it is found that all the strategies are penalizing in terms of SFC when compared to a cycle which does not consider fuel conditioning. It is found that since the cycles are redesigned for the same 3-

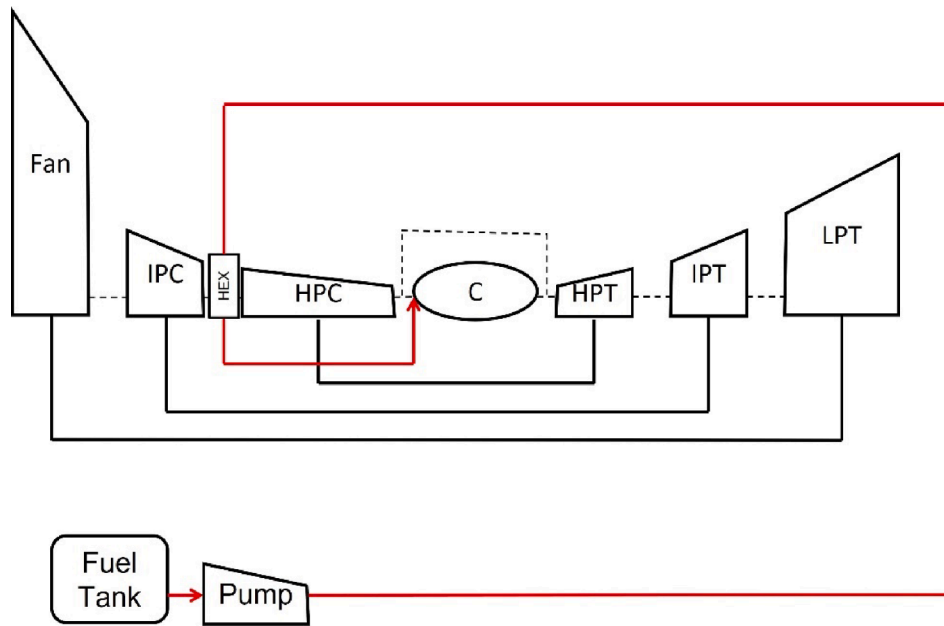

Fig. 10. Schematic of an intercooling fuel conditioning setup on a 3-spool engine architecture.

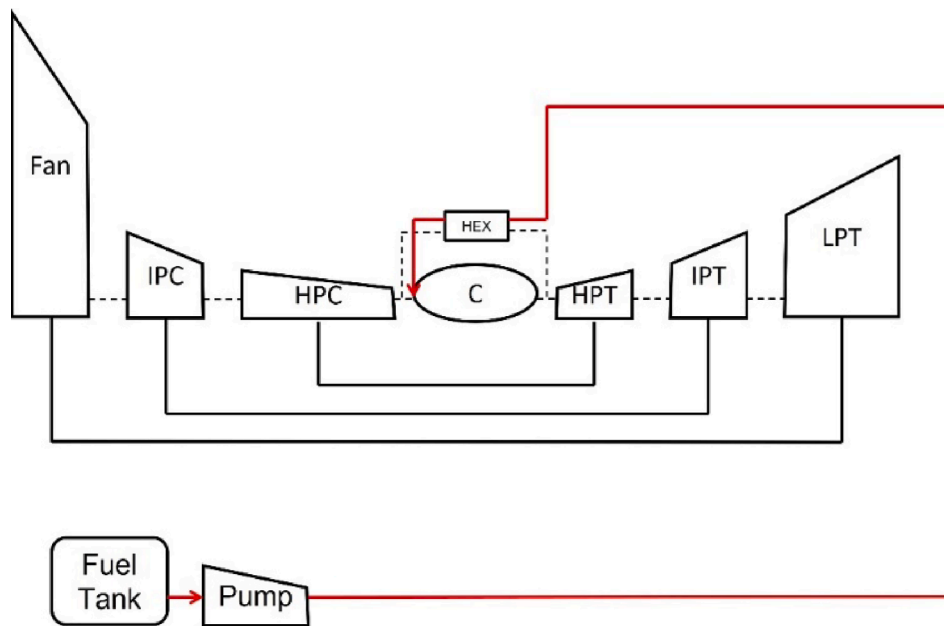

Fig. 11. Schematic of a bleed air fuel conditioning setup on a 3-spool engine architecture.

point thrust requirements, the core size is increased to account for the higher fuel conditioning requirements while maintaining the thrust. In the case of bleed air heating, the cooling flows are reduced by 1.7 % and as result, the core produces more power. Consequently, for the same thrust, the core size is reduced. However, since the cooling flows reduction is greater than the core size reduction, the relative air mass flows into the combustor are increased which increases the SFC for the same thrust. The electric heater is the most penalizing strategy in terms of SFC. Correspondingly, its higher thermal power requirements are

observed in Table 10. The SFC penalty of preheater with bleed air strategy includes the Ammonia fuel burned in the preheater setup along with the SFC penalty of bleed air. Exhaust heating strategy causes the engine to lose thrust. Since the cycles are redesigned for the same thrust, the core size is increased for the same take-off T40. Intercooling provides the least penalizing cycle design in terms of SFC. Intercooling allows cooler temperatures at the HPC blade exit. Since, the cycles are redesigned to the same take-off T30, the OPR is higher. This is observed in Table 9 and as a result, to drive the higher OPR, higher T40 is needed.

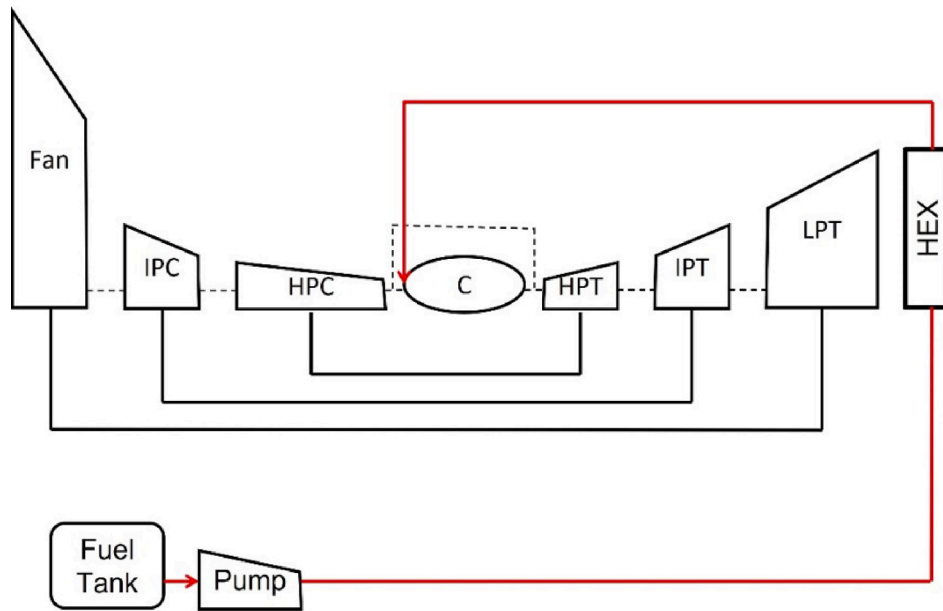

Fig. 12. Schematic of an exhaust fuel conditioning setup on a 3-spool engine architecture.

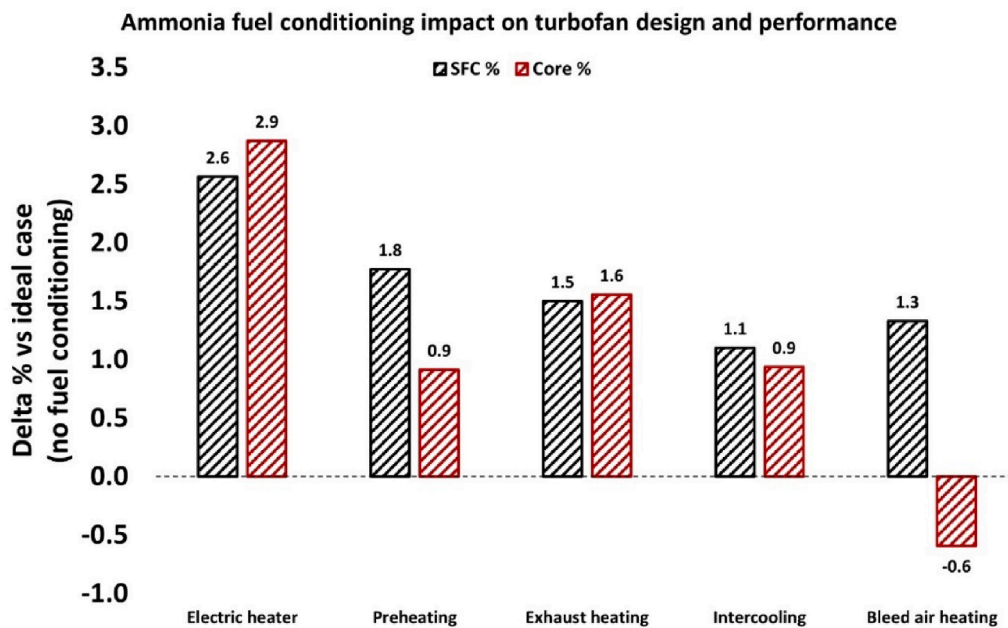

Fig. 13. Fuel conditioning impact on turbofan design and performance at MCR.

Table 9
MCR T40 and OPR differences compared to ideal case (no fuel conditioning).

	E. heater	Preheating with bleed air	Exhaust heating	Intercooling	Bleed air heating
T40 (K)	-1.66	-1.01	-0.46	1.55	0.06
OPR (%)	0.13	-0.03	-0.06	3.57	0.00

Table 10
3-point thermal power requirements.

	E.Heater	Preheating with bleed air	Exhaust heating	Intercooling	Bleed air heating
MCR (W)	543,000	532,000	538,000	536,000	537,000
MCL (W)	752,000	737,000	745,000	742,000	744,000
MTO (W)	2143,000	2093,000	2118,000	2107,000	2112,000

Rest of the strategies does not impact the design T40 and OPR as much as intercooling does. The maximum thermal power for fuel conditioning occurs at take-off requiring approximately 2.1 MW for 430 kN thrust class engine. It is worth noting that even after considering the fuel conditioning requirements of Ammonia fuel, BPR is still found to be

higher than the respective kerosene engine cycle. Considering the electric heater strategy which resulted in maximum increase in core size, the BPR is 12.6 compared to BPR 9.6 of kerosene cycle, all for the same fan size. This provides evidence that Ammonia as a fuel for turbofan engines could potentially lead to smaller and more compact cores in the future.

3.3. Ammonia as a hydrogen carrier

The significant range penalty posed by Ammonia aircraft was discussed earlier. A top-level assessment is conducted to investigate whether any mission benefits might be possible if Ammonia is used as a Hydrogen carrier. In literature, a study by the US department of energy [34] has reported that commercial cracking reactors for producing Hydrogen from Ammonia typically weigh around 2000–5000 kg and occupy 3–6 m³ of space while accounting for the cracking system efficiencies. These systems require catalysts and operating temperatures typically in the range of 773 K. More recently, Yuan et al [35,36] developed a photocatalytic technique which utilized LEDs (Light Emitting Diodes) at room temperatures to extract Hydrogen from Ammonia. Due to the preliminary nature of this assessment, the weight and efficiencies of such systems has not been considered as this is a field of continuous development.

In this assessment, Ammonia is carried in the wings with the same assumptions made earlier regarding storage. Ammonia is assumed to be converted to 100 % gaseous Hydrogen and burned in Hydrogen turbofan engines. Due to this conversion, Hydrogen is assumed to be injected at 300 K into the combustor. MTOW is maintained to respect the structural limitations of the aircraft. Since this is a retrofit exercise, the Hydrogen turbofan cycle is redesigned for the same fan size, same take-off T40 and take-off T30 as the baseline kerosene variant. The Hydrogen turbofan engine at design point MCR is presented in Table 11.

From Table 11, it is observed that even though the turbofan design impact of Hydrogen is not as high as Ammonia, it is still higher than kerosene variant since the BPR is higher. When comparing the ESFC with kerosene, it offers 2.5 % ESFC benefits. Hence, using Hydrogen as a fuel for future turbofan engines also provides opportunities to have smaller and compact cores compared to kerosene turbofan engines. The preliminary aircraft mission assessment shows that additional range is possible as presented in Table 12.

An additional range of 8.7 % is obtained when Ammonia is used as a Hydrogen carrier. This is obtained with a Hydrogen turbofan engine that is not redesigned as much as an Ammonia turbofan engine. The reason for this is that when Ammonia is used as a Hydrogen carrier, more energy is available in the tanks than when pure Ammonia is considered. To explain this, energy density MJ/L of the two cases are compared. Energy density of Ammonia is 12.7 MJ/L. Ammonia contains 3/17 mass ratio of Hydrogen in it. The density of Ammonia at its boiling point is 0.682 kg/L. Hence, Ammonia contains 0.120 kg/L of Hydrogen which translates into 14.4 MJ/L. This highlights the higher energy carrying capacity of Ammonia as a Hydrogen carrier and Ammonia's higher hydrogen content per volume compared to pure liquid Hydrogen whose density is only 0.071 kg/L.

Table 11
Design and performance of a Hydrogen fuelled turbofan engine.

	Hydrogen
BPR	10.7
ESFC (J/N. s)	588.1
SFC (gr/kN. s)	4.9
T40 (K)	1519.9
OPR	41.0
MCR FN (N)	64,100
MCL FN (N)	83,300
MTO FN (N)	345,100

Table 12
Performance of Ammonia as Hydrogen carrier at mission level.

	NH ₃ as H ₂ carrier	NH ₃	Units
MTOW	316,000	316,000	kg
OEW	162,000	161,000	kg
PAYLOAD	35,000	35,000	kg
FUEL	119,000	120,000	kg
Range	3847	3538	nm

Since this positive aspect of additional range capability is identified, an investigation is conducted to assess the impact of Ammonia cracking energy on this additional range capability.

Ammonia cracking (decomposition) into Hydrogen is given by the Eq. (5):

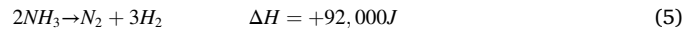

From Eq. (5), it is understood that for one mole of Ammonia, 46,000 J of endothermic energy is required to crack Ammonia into 1.5 mol of Hydrogen i.e 30,600 J is required for every mole of Hydrogen consumed by the turbofan engine. Following this philosophy, the impact of Ammonia cracking on Hydrogen turbofan cycle design is assessed through two strategies namely, electric heater drawing power from the high pressure turbine and exhaust heating utilizing a heat exchanger with 4 % pressure loss in the flow path. The Hydrogen turbofan engine is redesigned with 3-point cycle design strategy for the same fan size (diameter), take-off T40 and T30 as the baseline Hydrogen turbofan engine. The 3-point thrust requirements are the maintained the same to examine the impact on the cycles while delivering the same thrust. Ammonia cracking energy impact on Hydrogen turbofan engine is presented in Table 13.

The 3-point thermal power requirements to crack Ammonia based on strategies investigated are presented in Table 14.

It is observed from Table 13 that taking energy from exhaust is least penalizing compared to electric heating variant since the SFC increment is less in the exhaust heating. As a result, the change in Hydrogen turbofan design is less. In this case, the BPR reduced (core size increased 3.7 % compared to baseline) for the same fan size, take-off T40 and T30. Electric heating variant causes significant change in the Hydrogen turbofan design as this is observed by the reduction in BPR (core size has been increased 33.6 % compared to baseline). On observing the thermal power requirements to crack Ammonia into Hydrogen (Table 14) based on the Hydrogen turbofan engine fuel consumption rates, the thermal power is an order of magnitude higher compared to ones presented in Table 10 to condition Ammonia fuel itself. This shows the significant energy requirement to crack Ammonia into Hydrogen.

As a result of the increased SFC which accounts for the energy needed to crack Ammonia into Hydrogen, the electric heating variant results in 17.2 % loss in range compared to a pure Ammonia burning aircraft. The exhaust heating variant reduces the additional range capability from 8.7 % to 4.2 %. However, it must be noted that the additional cracking systems weight and efficiency are not considered in this preliminary assessment which might highly likely negate this range benefit compared to the pure Ammonia burning aircraft.

Table 13
Ammonia cracking impact on design and performance of Hydrogen Turbofan engine.

	Hydrogen (Baseline)	Electric Heater	Exhaust Heating
BPR	10.7	7.8	10.2
ESFC (J/N. s)	588.1	762.6	612.7
SFC (gr/kN. s)	4.9	6.3	5.1
T40 (K)	1519.9	1502.2	1524.1
OPR	41.0	41.3	41.3

Table 14
3-point thermal power requirements to crack Ammonia.

	Exhaust Heating	Electric Heating
MCR (W)	4984,000	6231,000
MCL (W)	6935,000	8491,000
MTO (W)	19591,000	24967,000

4. Conclusions

The impact of using Ammonia for civil aviation as a carbon free fuel is assessed through a retrofit case study involving an Airbus A350-1000 equivalent aircraft. It is found that due to the reduced lower heating value of Ammonia compared to kerosene, the payload-range capability of an Ammonia powered aircraft is significantly affected. Alternatively, the aircraft will need to be redesigned to compete with a kerosene counterpart for the same payload range capability. This will probably lead to a heavier aircraft with higher thrust requirements. The global warming reduction potential of Ammonia powered aircraft is up to 75 %. This reduction is without the effects of contrails as this is beyond the scope of the study. Reduction in block energy consumption was observed up to 3.1 %. Reduced LHV of Ammonia means any weight saving technology in the future is expected to have a lower impact on Ammonia aircraft compared to kerosene variant.

Using Ammonia as a fuel for future turbofan engines allows significant engine redesign opportunities having both smaller and compact cores with higher thermal efficiencies. For the investigated case, smaller and compact cores (smaller engine footprint) resulted a lighter engine with 9.37 % reduction in engine weight compared to kerosene counterpart of same thrust class.

One should note that Ammonia fuelled turbofan engines can have a greater tendency to generate fuel NO_x since Ammonia as a nitrogen hydride has nitrogen in it. However, since the adiabatic flame temperatures of Ammonia combustion are lower, the thermal NO_x due to atmospheric nitrogen could be lower. These two factors can be competing in terms of the total NO_x produced. Precautionary measures must be considered while handling Ammonia fuel due to its toxic nature.

Fuel conditioning assessment revealed that under the engine operating conditions for the 3 points namely MCR, MCR and MTO, Ammonia existed as a subcooled liquid and hence indicated favourable handling conditions for the fuel management system. The thermal power requirement for fuel conditioning is found to be maximum at the maximum power condition for the engine i.e. MTO of approximately 2.1 MW for the investigated thrust class of 430 kN. Various strategies to implement fuel conditioning are investigated namely electric heating, preheating with bleed air, intercooling, bleed air heating and exhaust heating. Their impact on turbofan design is assessed with Intercooling showcasing least penalizing performance and design when a 3 point cycle design approach is considered. The various core size differences (different BPRs) resulting from the assessed fuel conditioning strategies indicates fuel conditioning to be a major design driver for future Ammonia fuelled turbofan engines.

From preliminary initial assessments, Ammonia used as Hydrogen carrier showed promise as it provided a range extension of 8.7 %. This is attributed to the fact that more energy is available in tanks when Ammonia is used as a Hydrogen carrier as compared to pure Ammonia case. However, when considering the energy required to crack Ammonia into Hydrogen, the additional range capability reduces highlighting the challenges at mission level once the cracking systems weight and efficiencies are considered. The significant energy requirement to crack Ammonia into Hydrogen which is an order of magnitude higher than Ammonia fuel conditioning itself, has significant Hydrogen turbofan design implications in terms of core size and operating temperatures.

CRedit authorship contribution statement

Sarath Sasi: Writing – review & editing, Writing – original draft, Visualization, Formal analysis, Data curation, Conceptualization. **Christos Mourouzis:** Supervision. **David John Rajendran:** Supervision. **Ioannis Roumeliotis:** Supervision. **Vassilios Pachidis:** Supervision. **Justin Norman:** Supervision.

Declaration of competing interest

The authors declare that they have no known competing financial interests or personal relationships that could have appeared to influence the work reported in this paper.

Data availability

The data used for the research are public domain data as referenced appropriately in the manuscript.

Acknowledgements

The author would like to acknowledge Rolls-Royce plc and Cranfield University for funding this doctoral program.

References

- [1] "Long term global aspirational goal (LTAG) for international aviation." <https://www.icao.int/environmental-protection/Pages/LTAG.aspx> (accessed Jan. 26, 2023).
- [2] Astm. "ASTM D7566 standard specification for aviation turbine fuel containing synthesized hydrocarbons", in annual book of ASTM. Standards 2022:1–40. <https://doi.org/10.1520/D7566-22A>.
- [3] "Aircraft Technology Roadmap to 2050," IATA, 2019. <https://www.iata.org/contentassets/8d19e716636a47c184e7221c77563c93/Technology-roadmap-2050.pdf> (accessed Sep. 27, 2022).
- [4] Lokesh K, Sethi V, Nikolaidis T, Goodger E, Nalianda D. Life cycle greenhouse gas analysis of biojet fuels with a technical investigation into their impact on jet engine performance. *Biomass Bioenergy* 2015;77:26–44. <https://doi.org/10.1016/j.biombioe.2015.03.005>.
- [5] N. C. Kailos, "Utilization of Ammonia as an Alternative Fuel in Army Aircraft Engines: USAAVLABS Technical Report 66-52," p. 63, 1966, [Online]. Available: <https://apps.dtic.mil/sti/pdfs/AD0638360.pdf>.
- [6] Newhall HK, Starkman ES. Theoretical performance of ammonia as a gas turbine fuel. *SAE Tech Pap* 1966. <https://doi.org/10.4271/660768>.
- [7] Verkamp FJ, Hardin MC, Williams JR. Ammonia combustion properties and performance in gas-turbine burners. *Symp Combust* 1967;11(1):985–92. [https://doi.org/10.1016/S0082-0784\(67\)80225-X](https://doi.org/10.1016/S0082-0784(67)80225-X).
- [8] D. . Pratt, "Performance of ammonia-fired gas-turbine combustors," *Tech. Rep. No.9, DA-04-200-AMC-791(x), Berkeley Univ. Calif.*, 1967, [Online]. Available: <http://www.dtic.mil/dtic/tr/fulltext/u2/657585.pdf>.
- [9] Stillwell WH. X-15 research results. Report, NASA, Washington, DC, USA: Tech; 1965.
- [10] Iki N, et al. Micro gas turbine firing kerosene and ammonia. *Proc ASME Turbo Expo Aug.* 2015;8. <https://doi.org/10.1115/GT2015-43689>.
- [11] Kurata O, et al. Performances and emission characteristics of NH₃-air and NH₃CH₄-air combustion gas-turbine power generations. *Proc Combust Inst Jan.* 2017;36(3):3351–9. <https://doi.org/10.1016/J.PROCI.2016.07.088>.
- [12] Goldmann A, et al. A study on electrofuels in aviation. *Energies* 2018;11(2):1–23. <https://doi.org/10.3390/en11020392>.
- [13] "Reaction Engines, STFC engaged in ground-breaking study on ammonia fuel for a sustainable aviation propulsion system | Reaction Engines - Making Beyond Possible." <https://reactionengines.co.uk/reaction-engines-stfc-engaged-in-ground-breaking-study-on-ammonia-fuel-for-a-sustainable-aviation-propulsion-system/>.
- [14] "News | Ammonia could fuel the future of sustainable flight | RTX." <https://www.rtx.com/news/2020/12/09/ammonia-could-fuel-the-future-of-sustainable-flight>.
- [15] "Zero-carbon Ammonia-Powered Turboelectric (ZAPTURBO) Propulsion System." <https://arpa-e.energy.gov/technologies/projects/zero-carbon-ammonia-powered-turboelectric-zapturbo-propulsion-system>.
- [16] Mashruk S, Zitouni SE, Brequigny P, Mounaim-Rousselle C, Valera-Medina A. Combustion performances of premixed ammonia/hydrogen/air laminar and swirling flames for a wide range of equivalence ratios. *Int J Hydrogen Energy* 2022; 47(97):41170–82. <https://doi.org/10.1016/j.ijhydene.2022.09.165>.
- [17] Blain L. First ammonia-powered jet flight in 2023: a roadmap to clean aviation. (accessed Jun 2022;05:2022). <https://newatlas.com/aircraft/aviation-h2-ammonia-fuel-jet-aircraft/>.
- [18] Otto M, Vesely L, Kapat J, Stoia M, Applegate ND, Natsui G. Ammonia as an aircraft fuel: thermal assessment from airport to wake. *Proc ASME Turbo Expo* 2022;2: 1–13. <https://doi.org/10.1115/GT2022-84359>.

- [19] Ansell PJ. Review of sustainable energy carriers for aviation: benefits, challenges, and future viability. *Prog Aerosp Sci Aug.* 2023;141:100919. <https://doi.org/10.1016/J.PAEROSCI.2023.100919>.
- [20] S. Sasi, C. Mourouzidis, I. Roumeliotis, T. Nikolaidis, V. Pachidis, and J. Norman, "Impacts of Alternative Aviation Fuels on Engine Cycle Design and Aircraft Mission Capability," in *ASME Turbo Expo 2023: Turbomachinery Technical Conference and Exposition*, Jun. 2023. doi: : 10.1115/GT2023-101114.
- [21] A. H. Lefebvre and D. R. Ballal, *Gas Turbine Combustion Third Edition*, Third. CRC Press, 2010. doi: 10.1201/9781420086058.
- [22] Bicer Y, Dincer I. Life cycle evaluation of hydrogen and other potential fuels for aircrafts. *Int J Hydrogen Energy* 2017;42(16):10722–38. <https://doi.org/10.1016/j.ijhydene.2016.12.119>.
- [23] Goodger EM. *Alternative Fuels* London: Macmillan Education UK 1980. <https://doi.org/10.1007/978-1-349-04364-4>.
- [24] MacMillan WL. Development of a modular-type computer program for the calculation of gas turbine off-design performance. Cranf Univ PhD Thesis 1974.
- [25] P. Lolis, "Development of a Preliminary Weight Estimation Method for Advanced Turbofan Engines," *Cranf. Univ. PhD Thesis*, no. July, p. 214, 2014, [Online]. Available: <https://dspace.lib.cranfield.ac.uk/handle/1826/9244>.
- [26] S. G. and B. J. McBride, "Computer Program for Calculation of Complex Chemical Equilibrium Compositions and Applications." NASA Reference Publication 1311, 1996.
- [27] McCullers L. "FLOPS flight optimization system user's guide, release 8.21. ATK space division. NASA Langley Research Center" 2011.
- [28] F. C. and H. 2 J. Undertaking. "Hydrogen-powered aviation : a fact-based study of hydrogen technology, economics, and climate impact by 2050", publications. Office 2020. <https://doi.org/10.2843/471510>.
- [29] E. W. L. and I. H. B. and M. L. H. and M. O. McLinden, "REFPROP." 2018. doi: <https://doi.org/10.18434/T4/1502528>.
- [30] Samuelsson S, Gronstedt T, Kyprianidis KG. Consistent conceptual design and performance modeling of aero engines. *Proc ASME Turbo Expo Aug.* 2015;3. <https://doi.org/10.1115/GT2015-43331>.
- [31] Airbus. "Airport and Maintenance Planning" 2022. <https://www.airbus.com/en/airport-operations-and-technical-data/aircraft-characteristics>.
- [32] "13.3 Aircraft Range: the Breguet Range Equation." <https://web.mit.edu/16.unified/www/FALL/thermodynamics/notes/node98.html>.
- [33] Khandelwal B, Karakurt A, Sekaran PR, Sethi V, Singh R. Hydrogen powered aircraft: the future of air transport. *Prog Aerosp Sci* 2013;60:45–59. <https://doi.org/10.1016/j.paerosci.2012.12.002>.
- [34] U.S. Department of Energy, "Potential Roles of Ammonia in a Hydrogen Economy," *Energy*, pp. 1–23, 2006, [Online]. Available: https://www.hydrogen.energy.gov/pdfs/nh3_paper.pdf.
- [35] Y. Yuan et al., "Earth-abundant photocatalyst for H2 generation from NH3 with light-emitting diode illumination," *Science (80-.)*, vol. 378, no. 6622, pp. 889–893, Nov. 2022, doi: 10.1126/science.abn5636.
- [36] S. Writers, "Researchers create green fuel with the flip of a light switch," 2022. https://www.oilgasdaily.com/reports/Researchers_create_green_fuel_with_the_flip_of_a_light_switch_999.html.

Ammonia for civil aviation: a design and performance study for aircraft and turbofan engine

Sasi, Sarath

2024-05-01

Attribution-NonCommercial-NoDerivatives 4.0 International

Sasi S, Mourouzidis C, Rajendran DJ, et al., (2024) Ammonia for civil aviation: a design and performance study for aircraft and turbofan engine. *Energy Conversion and Management*, Volume 307, May 2024, Article number 118294

<https://doi.org/10.1016/j.enconman.2024.118294>

Downloaded from CERES Research Repository, Cranfield University