



THE COLLEGE OF AERONAUTICS  
CRANFIELD

DEVELOPMENT OF A 3-COMPONENT STRAIN-GAUGE  
FOR USE ON THE WHIRLING ARM

by

W. G. Holloway, W. Osbourn and P. E. Kumar

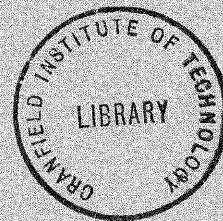

October, 1969



THE COLLEGE OF AERONAUTICS

DEPARTMENT OF AERODYNAMICS

Development of a 3-component strain-gauge  
for use on the Whirling Arm

- by -

W.G. Holloway, W. Osbourn and P.E. Kumar

S U M M A R Y

This note covers the development of two strain-gauge balances for use on the Whirling Arm Facility of the College. The main requirements for this balance were:- (a) to withstand 700 lbs of sideload without it interfering with the lift, drag and pitching moment measurements, (b) to have a high sensitivity without too heavy a structure. The balance originally designed for this purpose proved to be unacceptable because of undue interference due to sideload and the non-repetitive nature of its calibration curves. With the information gained from this first balance a second balance of exceedingly simpler design, was manufactured and was found to give good calibration curves and sensitivity, with little interference from sideloads. A trouble free method of recording the signals from the strain-gauge bridges is being developed and should be operating within the near future.

It is concluded that a new model, with its c.g. lying on the transverse centre-line of the balance, will be needed if sideload interference is to be further reduced.

Contents

	<u>Page No.</u>
Summary	
List of symbols	1
1.0 Introduction	2
1.1.0 Mk. I balance	2
1.1.1 Calibration of Mk. I balances	2
2.0 Design of a new strain-gauge balance	3
2.1.0 Calibration of Mk. 2 balance prototype	3
2.1.1 Calibration of Mk. 2 balances	
3.0 Installation of new balances of the Whirling Arm	6
3.1.0 Instrumentation	6
3.2.0 Static calibration of balances	7
Future programme	8
Conclusions	8
References	9
Figures	



List of symbols

$S_{1,2,3}$	Deflections on recorder due to strain gauge bridges 1,2,3 (in.)
$f_{1-6}$	} calibration factors
$\epsilon_{1-6}$	
$h_{1-6}$	
L	Lift (lbf.)
N	Yawing moment (lbf. in.)
Y	Sidelforce (lbf.)
M	Pitching moment (lbf. in.)
D	Drag (lbf.)
	Rolling moment (lbf. in.)
x	Point of application of lift load measured from balance centre-line (at quarter chord).
z	Point of application of drag load measured from balance neutral axis.

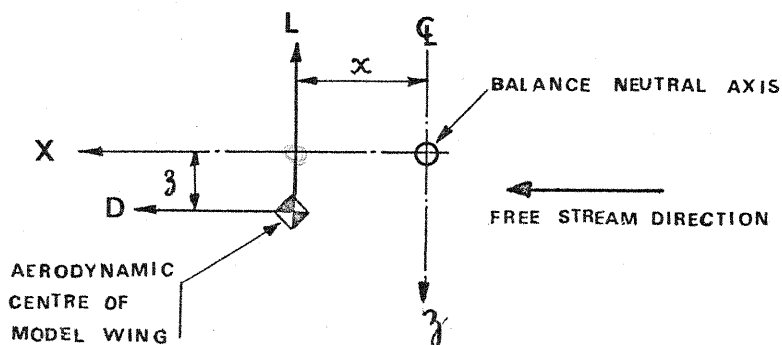

## 1.0 Introduction

Strain-gauge balances are unique in that they are designed specifically for a given model or a particular testing facility, and the balance needed for use on the Whirling Arm facility was by no means an exception to this rule. It was decided a 3-component balance to measure lift, drag and pitching moment acting on the model. The requirements for such a balance were:-

- (1) Structural strength to withstand up to 700 lbs of sideload resulting from the centrifugal forces acting on the model with very little deformation of the balance as a whole.
- (2) Little or no interference on the balance components due to this large sideload.
- (3) As high a sensitivity as possible, compatible with (1), to measure lifts up to 165 lbf., drags up to 20 lbf. and pitching moments up to 1000 lb.in.
- (4) The need to manufacture two identical balances to be mounted between the model and its struts.

### 1.1.0 Mk. I balance:

Fig.1 shows a general arrangement and a diagrammatic sketch of the first design (to be referred to as Mk. I) of the balance. The relevant dimensions of the strain-gauged members can be seen in Fig. 2. The model and the attached balance(s) were pivoted about a spindle rigidly attached to the support strut and precision ball-bearing races were incorporated between the spindle and the 'live' body of the balance. This was in order to eliminate any large friction losses in the relative displacements between the spindle and the balance body. Loads were transmitted through ball-point contacts onto the lift and moment component members in the hope of isolating other interference loads. All forces and moments produced bending stresses in their relevant structural members, but also induced compressive stresses due to interference on the other members.

The strain-gauges had been initially attached along the neutral axes of each of the balance component members, in order to eliminate sideload effects. This proved to be very unsatisfactory with regard to the output signal strength from the strain-gauge bridges (determined during preliminary testing) and the gauges were reattached towards the 'built-in' ends of each balance member. The balances were then calibrated.

### 1.1.1 Calibration of Mk. I balances

The calibration rig for these balances can be seen in Figures 3 and 4(a) and (b). The two balances were mounted on the model struts, which are used on the Whirling Arm, and were interconnected by bolting onto a rigid metal plate simulating the model wing. The signals from the lift, drag and pitching moment bridges of each balance were fed into a 6-channel speedomax recorder. A drag load was applied at the centre-line of the metal plate and the signals from the strain-gauge bridges recorded on the

speedomax chart. This was repeated for successively increasing and decreasing drag loads and the curves of Fig. 5 were obtained. It can be seen that the moment bridges were most sensitive to drag loads whilst the drag bridges themselves had large hysteresis loops on application and removal of the load. This was thought to be due to misalignment of the ball tips restraining the balance components and readjustment of these yielded the results shown in Fig. 6. Although the drag balances had no hysteresis, the lift and moment balances were far too sensitive to drag. Moreover, since the slopes of the traces are different in Figs. 5 and 6, it was concluded that their repeatability over a period of time would be uncertain especially when the ball-tips grew slack. Checks with the lift balance structurally isolated resulted in Figure 7. The moment balance was far too sensitive to drag loads, sideloads (along the balance centre line) and combinations of sideloads, drag and lift were applied to the balances and various minor modifications, such as removing the balance bearing journals and spacers, were also made. The result were, however, disappointing in all cases with non-linear calibration curves being the rule rather than the exception. In view of this it was decided to attach the lift component ball restrains directly onto the struts in order to get more movement on the lift balance relative to earth. This modification resulted in a significant improvement in the linearity of the curves and the drag balance was found to be almost free of lift and moment interference as can be seen in Fig. 8. However, the zeros of the lift and moment balances kept shifting due to slip between the ball tips and the strut and consequently this configuration was found to be unsatisfactory.

It was suggested that, in view of the complexity of the present balance, a simplified approach would yield more workable results. A configuration using two drag balances in tandem mounted from a single strut (as seen in Fig. 9) was considered first. The drag and moment calibration (the latter due to 14 lbf. lift acting at different chordwise stations) can be seen in Figs. 10(a) and 10(b). The curves are seen to be reasonably linear. The effects of different values of lift and drag loads and their combination with sideloads was also investigated and the results were found to be linear. It was thus thought that a new strain-gauge balance based on the tandem-balance principle warranted further investigation.

## 2.0 Design of a new strain-gauge balance

The prototype of this new balance can be seen in Fig. 11 installed on the calibration rig. The relevant dimensions and strain-gauge positions are noted in Fig. 12(a) whilst the bridge circuit used can be seen in Fig. 12(b).

### 2.1.0 Calibration of Mk. 2 balance prototype

Typical calibration curves obtained can be seen in Figs. 13(a), (b) and (c). There is no interference on the drag balance due to the application of a pitching moment (or lift). A drag load interferes with the lift and moment bridges and a sideload effects all three bridges. However, the linearity of the calibration is good and it was decided to go ahead with the new design and make two balances for use on the Whirling Arm.

#### 2.1.1 Calibration of Mk. 2 balances

It was decided to calibrate each balance separately at first and to then

calibrate them combined in situ on the whirling arm. This would show up any differences in signal characteristic due to errors in manufacture between the two balances. All calibrations were made with a bridge voltage of 6v. and all deflections of the speedomax pointer were taken positive to the right and negative to the left.

The balances were calibrated with the application of lift, drag and sideloads (the latter being applied 2.57 m. aft of the balance transverse centre lines and  $\frac{3}{4}$  in. below their bases), in various combinations and with the applications of each load on its own.

General expressions for the output signals from the strain gauge balances can be written as:

$$\left. \begin{aligned} S_1 &= f_1L + f_2N + f_3Y + f_4M + f_5D + f_6 \\ S_2 &= g_1L + g_2N + g_3Y + g_4M + g_5D + g_6 \\ S_3 &= h_1L + h_2N + h_3Y + h_4M + h_5D + h_6 \end{aligned} \right\} \quad (1)$$

Although the present balance is essentially a 3-component one (L,D,M), interference effects due to yawing and rolling moments and sideloads will effect the main lift, drag and pitching moment signals being recorded.

The application of a lift load alone will give a signal  $S_1 = f_1L + f_4L.x$  and similarly for  $S_2$  and  $S_3$ .

$$\left. \begin{aligned} \therefore \frac{S_1}{L} &= f_1 + f_4x \\ \text{and } \frac{S_2}{L} &= g_1 + g_4x \\ \frac{S_3}{L} &= h_1 + h_4x \end{aligned} \right\} \quad (2)$$

A drag load acting on its own will, in general, give

$$\begin{aligned} S_1 &= f_4M + f_5D \\ &= f_4D.z + f_5D \end{aligned}$$

and hence

$$\left. \begin{aligned} S_1/D &= f_4z + f_5 \\ S_2/D &= g_4z + g_5 \\ S_3/D &= h_4z + h_5 \end{aligned} \right\} \quad (3)$$

Since in the present calibration tests the point of application of the sideload Y was not varied, the values of N and  $\dots$  arose only as a result of varying Y. Subsequently it was not possible to obtain  $(f,g,h)_{2,3,6}$  discretely. Their collective influence was obtained from recordings of the values of  $S_{1,2,3}$  due to varying sideloads.





$$\left. \begin{aligned} S_1 &= - 0.175D + x'_y \\ S_2 &= - 0.150L - .078M + 0.212D + p'_2 \\ S_3 &= + 0.170L - .084M + 0.214D + p'_3 \end{aligned} \right\} \quad (5)$$

The relations (4) and (5) enable the lift, drag and pitching moments to be determined once the sideload and S are known.

The errors involved in the estimation of L, D and M entail:

- (a) the sensitivity of the speedomax,
- (b) the accurate determination of the application point for the loads,
- (c) ensuring that the sideload acts normal to the fore-and-aft line of the balance, and in a horizontal plane,
- (d) the stability of the bridge voltage,
- (e) the filtering of random mains interference,
- (f) the linearisation of some of the calibration curves.

With a sensitivity of 50 $\mu$ V/inch and a stable bridge voltage of 6V the lift, drag and pitching moments could be estimated to within  $\pm 3\%$ , and this was found to be acceptable for the time being in view of the simplicity of the design and the method of estimation.

The large difference between the curves of figs. 14(c) and 15(c) seems due to the difficulty in positioning the strain-gauges accurately in identical locations on the two balances. The curve of  $p_3$  for balance No. 1 is the worst case giving sideload interference deflections of the same order as the values of  $S_3$ .

It must be pointed out that the present calibration were done with the sideload acting along the transverse centre line of the balance and below its base. The centre of gravity of the current model wing, however, lies 2.67 in. aft of this centre line and  $\frac{3}{4}$ " below the base of the balance. This means that both yawing and rolling moments result. The effect of this offset c. of g. is allowed for in the calibration of the balances in situ on the Whirling Arm (see section 3.2.0).

### 3.0 Installation of new balances on the Whirling Arm

The balances can be seen mounted from the model wing struts on the Whirling Arm platform in fig. 16. Description and further details of the Whirling Arm can be found in ref. 1.

#### 3.1.0 Instrumentation

In order to obtain the six signals from the balances (3 signals per balance) in the control room it was decided to use the speedomax as a channel switch and amplifier prior to recording on a chart recorder in the control room. The speedomax was consequently mounted in the centre of the arm (as seen in fig. 17) along with its power supply. The signals from each of the balance bridges were fed to the speedomax, via the channel switch, by

means of shielded 6 core cables and the signal from the speedomax was transmitted to the control room via the mercury troughs available on the central column of the arm. The channel switching was remotely controlled from the control room using another set of mercury troughs; a channel indicator being mounted in the control room. The mains for the speedomax and the power supply were obtained via a pair of slip rings on the control column.

Fig. 18 shows a schematic arrangement of the link-up between the strain gauge balance and the control room.

### 3.2.0 Static calibration of balances

The whirling arm was locked in position and a tie-rod was attached, at one of its ends, to a lug located at the centre of gravity of the model wing profile and at the other end to a 400 lb. spring balance located outside the channel (the tie-rod passed through a small hole cut in the outer channel wall). Ensuring that the sideways pull on the model due to the spring balance (centrifugal load simulation) acted horizontally and at right angles to the wing end face, the balances were calibrated separately. The sideload interference on the lift, drag and pitching moment was found to be prohibitive. Further rate of strain gauges were mounted onto the model struts to obtain cancelling signals for the sideload interference but these proved to be unsatisfactory.

It became apparent that the way in which the strain gauge balances had been previously calibrated was not representative of the way in which they were now mounted on the wing. Previously each balance had been calibrated on a single strut whereas now cross-interference between the two model struts was occurring as a result of the main spar of the model. The balances were, therefore, primed as shown in the sketch below and the sideload interference was reduced to an acceptable level.

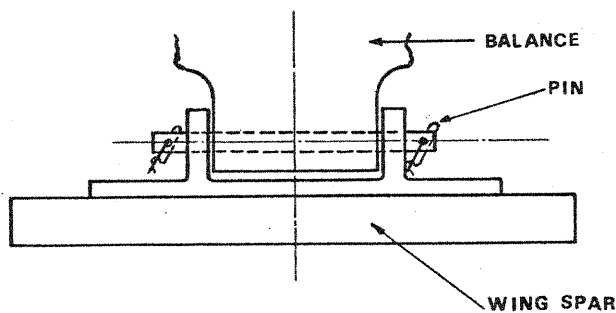

One of the major problems to date has been the effect of dampness on the circuitry of the speedomax. As two days produced the same zeros and, in addition, earthing problems resulted in more time being spent troubleshooting than in actual calibration of the balances. It was decided to use a separate system consisting of solid-state amplifiers, one for each bridge of the balance, which would eliminate the need for the speedomax and the channel switch.

Further details of the circuit and equipment used can be found in C.o.A. Electrical and Control Engineering Internal Technical Memo. 12 by B. Moffitt.

In addition to these amplifiers, precision helical potentiometers enabled each balance bridge to be zeroed prior to a calibration test (or a run) and consequently made the task of selecting a range on the recording instrument much easier. These zeroing potentiometers are coupled to the strain-gauge bridges via mercury troughs.

#### Future programme

One of the main difficulties in the design of the strain gauge balances has been the very large sideload as a result of centrifugal forces on the model. Moreover, since the balances are located at the quarter chord line of the present model whereas the model centre of gravity lies aft of this, a yawing moment results. Both the sideload and this yawing moment lead to non-linear calibration curves with interference between balance bridges.

A means of eliminating some of these effects would be to manufacture another lighter model wing with its centre of gravity at the model attachment point. This, in addition to giving smaller sideloads would also be advantageous towards the safety aspect of operation. It is to be recommended that a lighter model for specific use on the Whirling Arm be manufactured in the future.

The immediate task is the re-calibration of the strain gauge balances as soon as the electronics have been proved.

#### Conclusions

Much work has gone into the development of a suitable strain-gauge balance for use on the Whirling Arm Facility. After considerable testing the design of the 11k. 2 balance was found to be acceptable within the scope of the requirements. Calibration of this balance on the Whirling Arm will be completed as soon as the low drift amplifiers, necessary for the strain-gauge bridges, have been assembled and tested.

With the present model wing and its centre of gravity position, it is impossible to eliminate the sideload interference on the lift, drag and pitching moment bridges of the balance. It is concluded that for satisfactory operation the model c.g. should coincide with, or be as near as possible to,



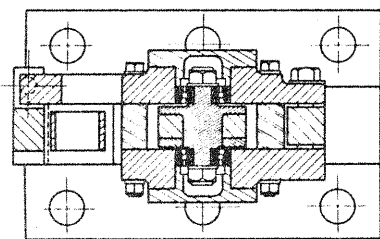
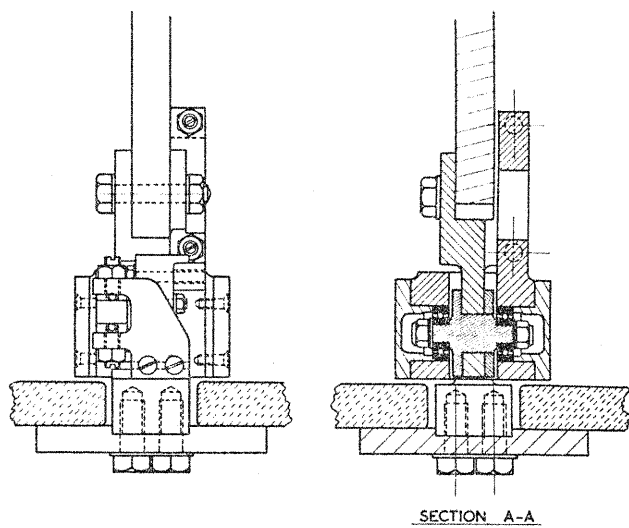
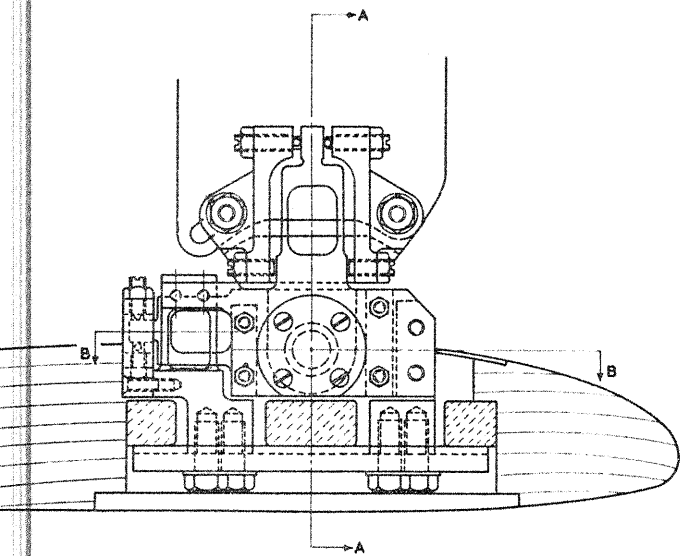

SECTION B-B

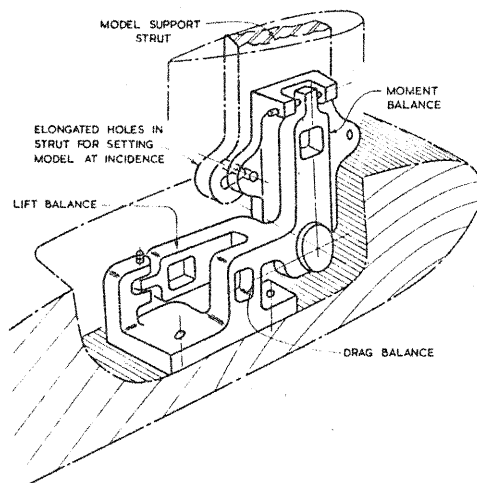

DIAGRAMMATIC SKETCH SHOWING THE STRAIN MEMBERS IN THE BALANCE.

FIG. I. THREE COMPONENT STRAIN GAUGE BALANCE FOR MODELS ON THE WHIRLING ARM.

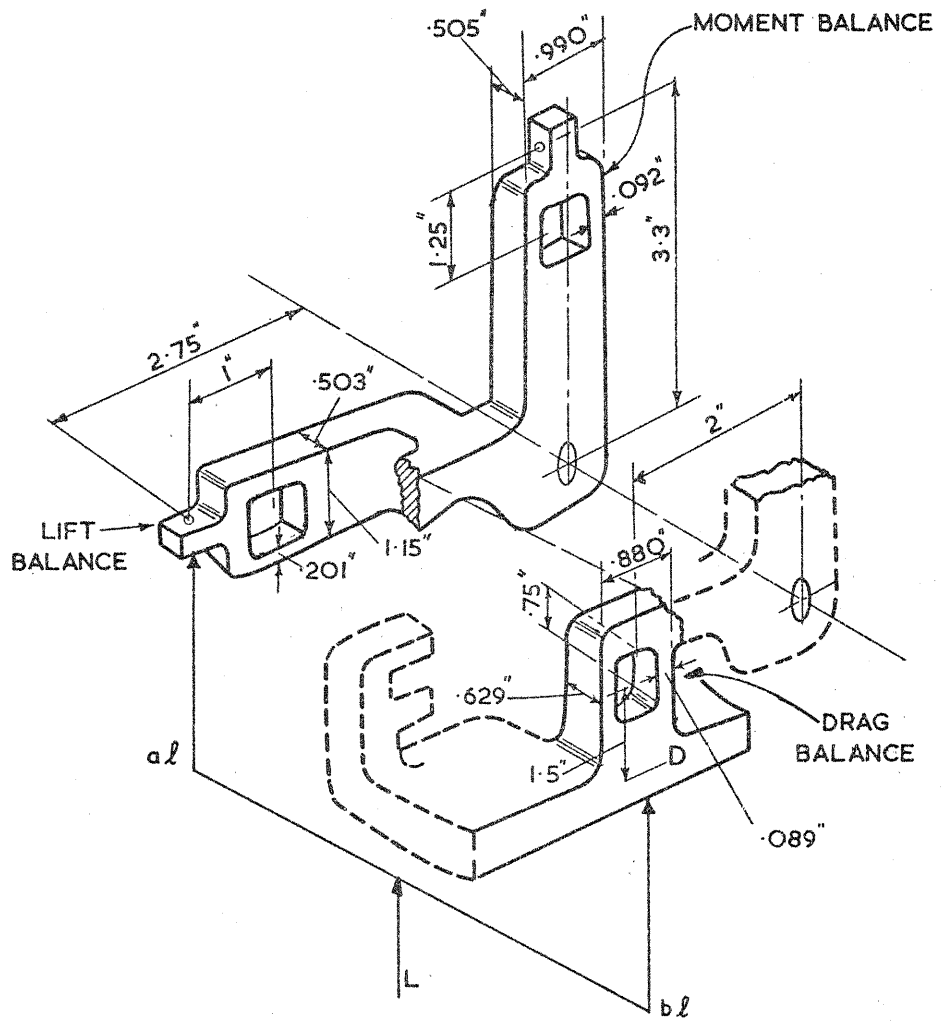

FIG.2. DIMENSIONS OF STRAIN GAUGE MEMBERS.

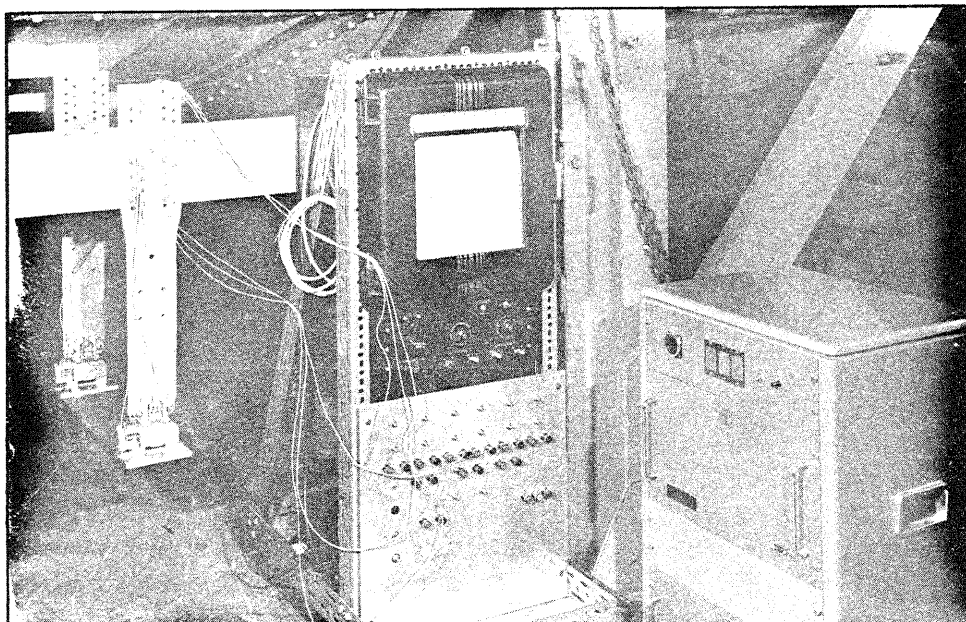

FIG. 3 CALIBRATION RIG FOR MK. 1 BALANCES

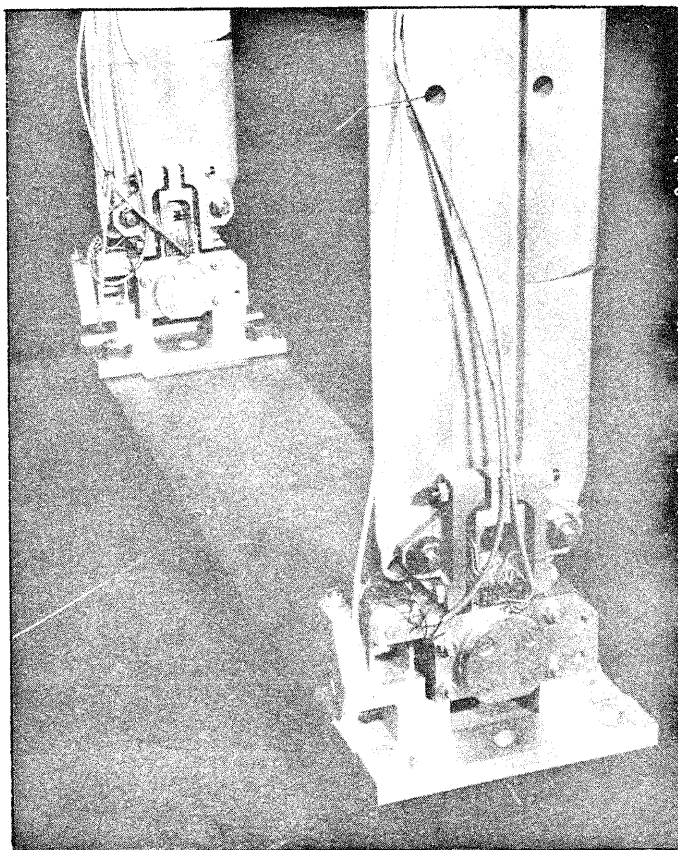

FIG. 4(a) MK. 1 BALANCES

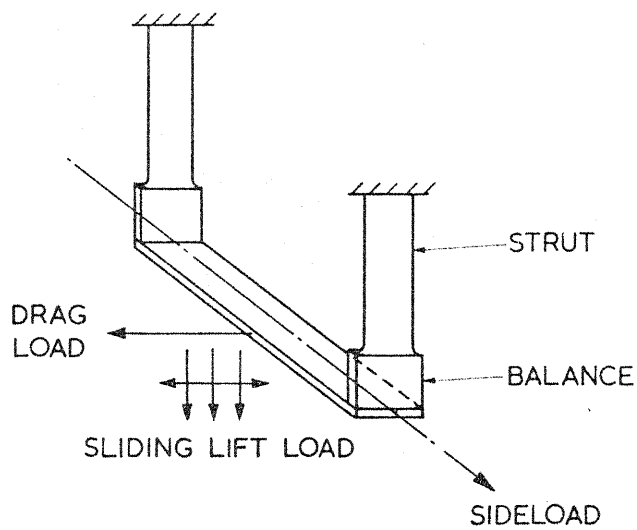

FIG. 4.(b) SCHEMATIC LAYOUT OF CALIBRATION RIG.

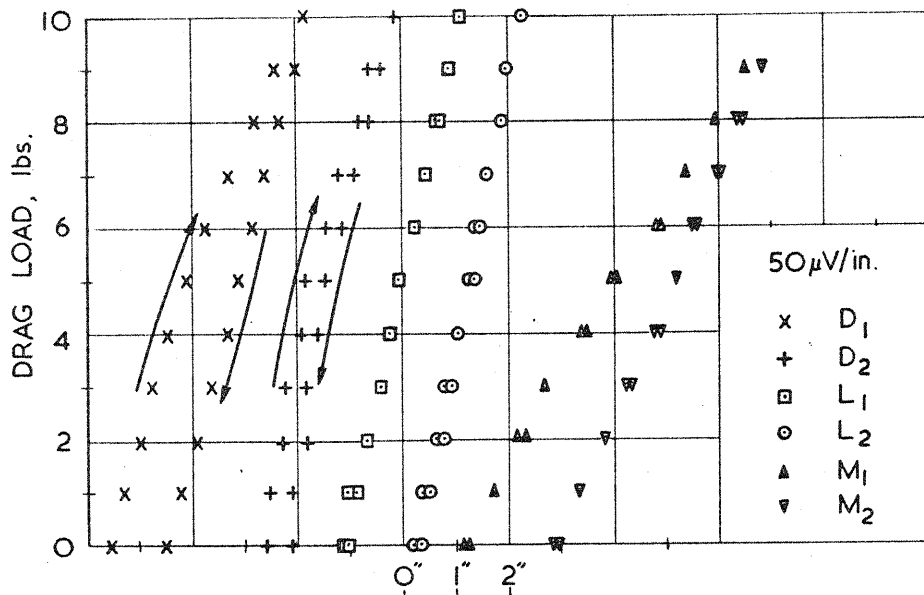

FIG. 5. DRAG CALIBRATIONS SHOWING HYSTERESIS ON DRAG BALANCES DUE TO MISALIGNMENT OF BALL TIPS.



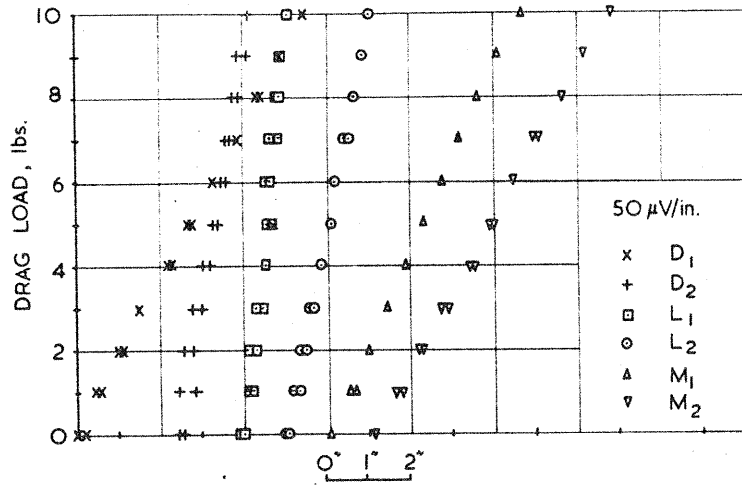

FIG.6. DRAG CALIBRATIONS WITH BALL TIPS ADJUSTED.

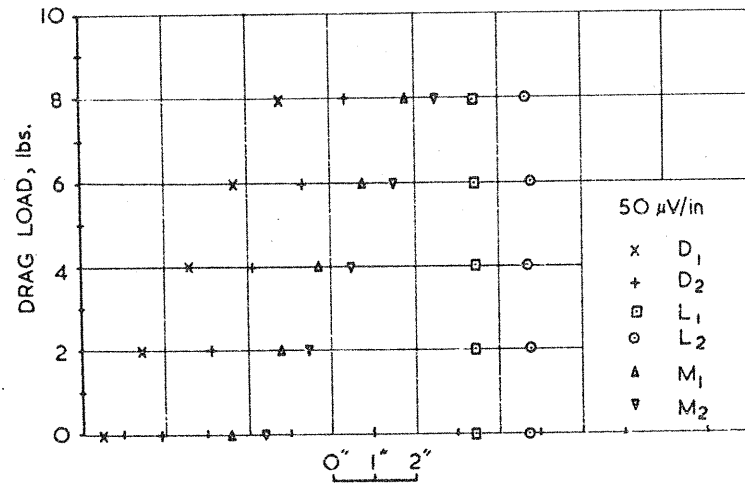

FIG.7. DRAG CALIBRATIONS WITH LIFT BALANCE ISOLATED.

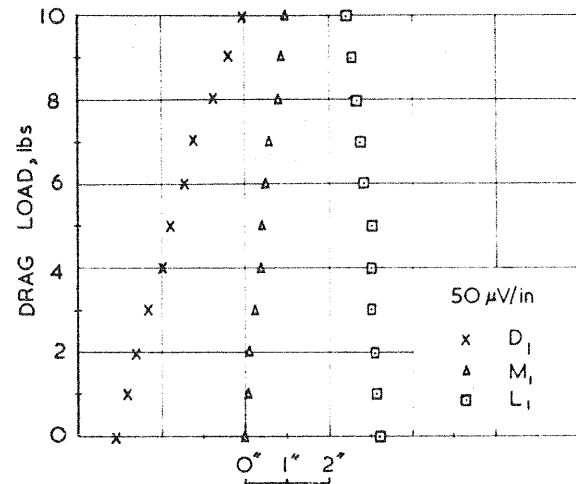

FIG.8. DRAG CALIBRATIONS WITH BALL TIPS BEARING AGAINST STRUT.

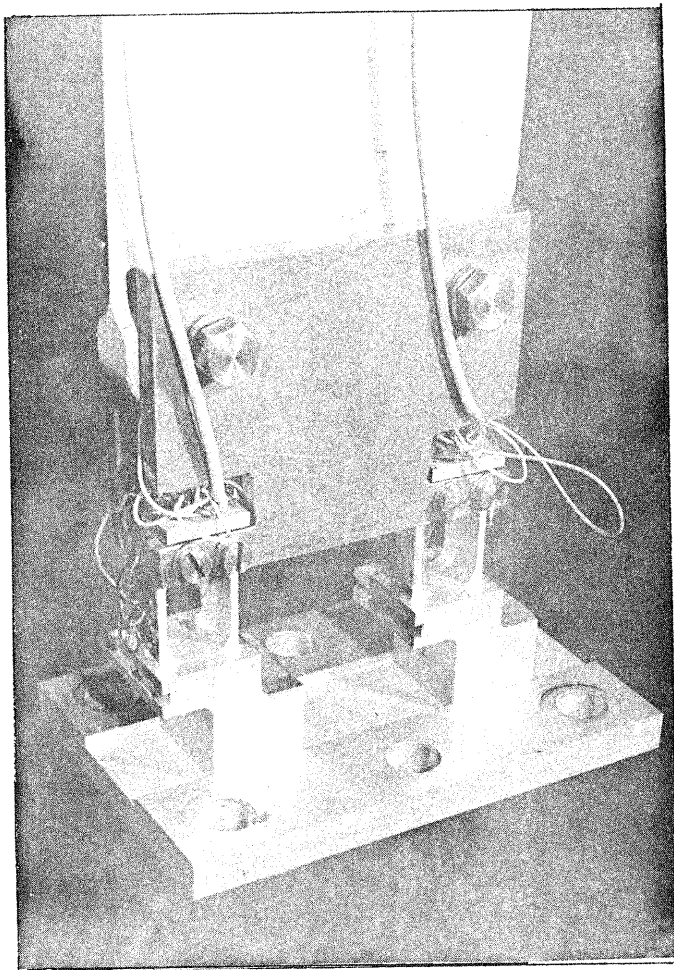

FIG. 9 DRAG BALANCES IN TANDEM

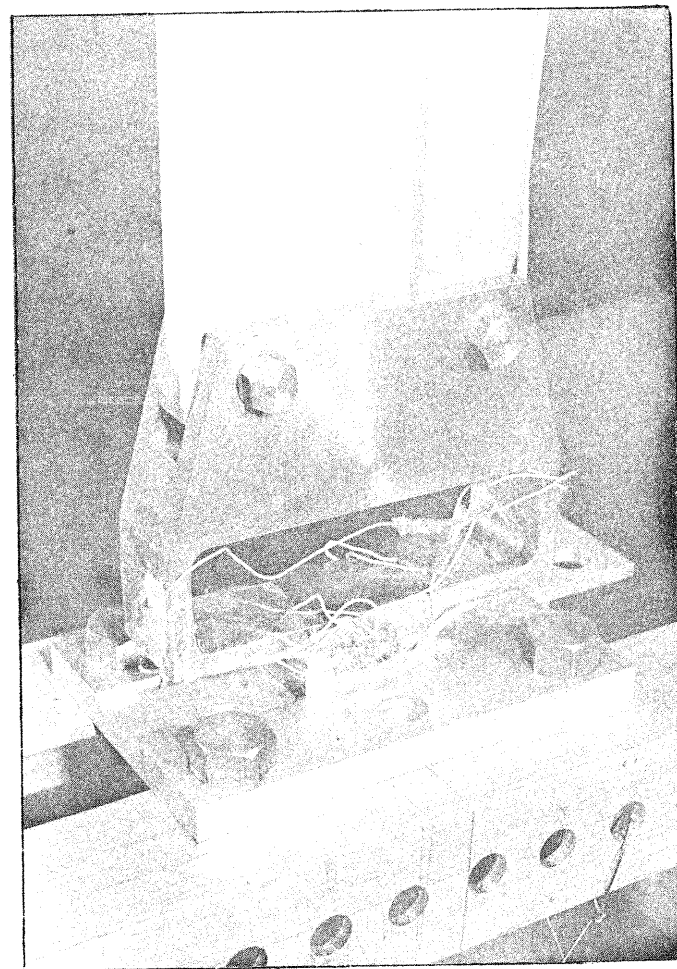

FIG. 11 PROTOTYPE OF MK. 2 BALANCE

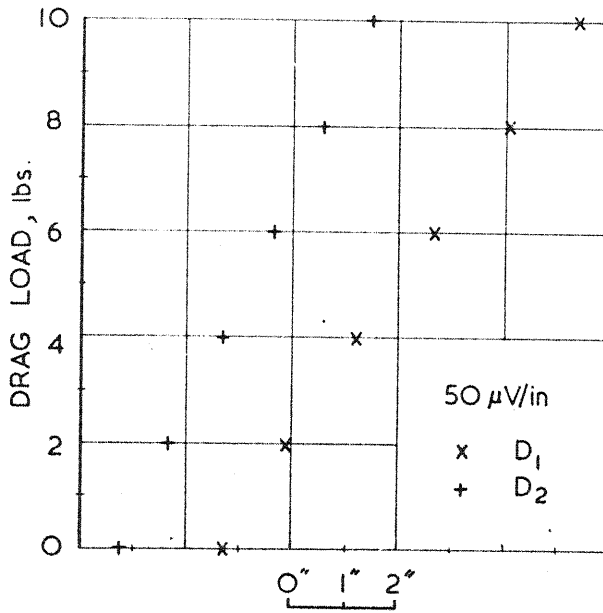

FIG.10a. DRAG CALIBRATION WITH DRAG BALANCES IN TANDEM.

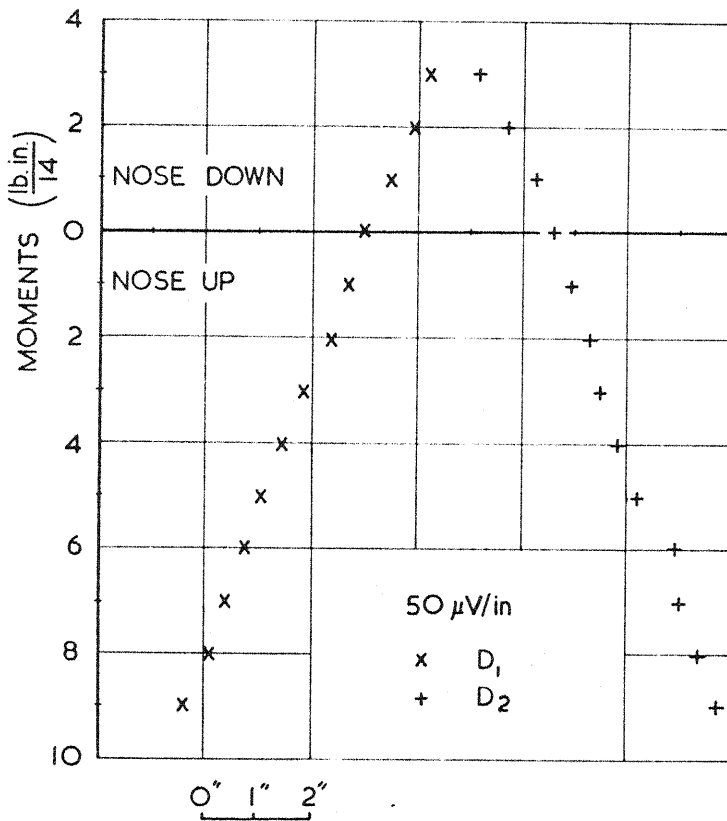

FIG.10 b. MOMENT CALIBRATION WITH DRAG BALANCES IN TANDEM (14 lb. LIFT ACTING AT DIFFERENT CHORDWISE POSITIONS)

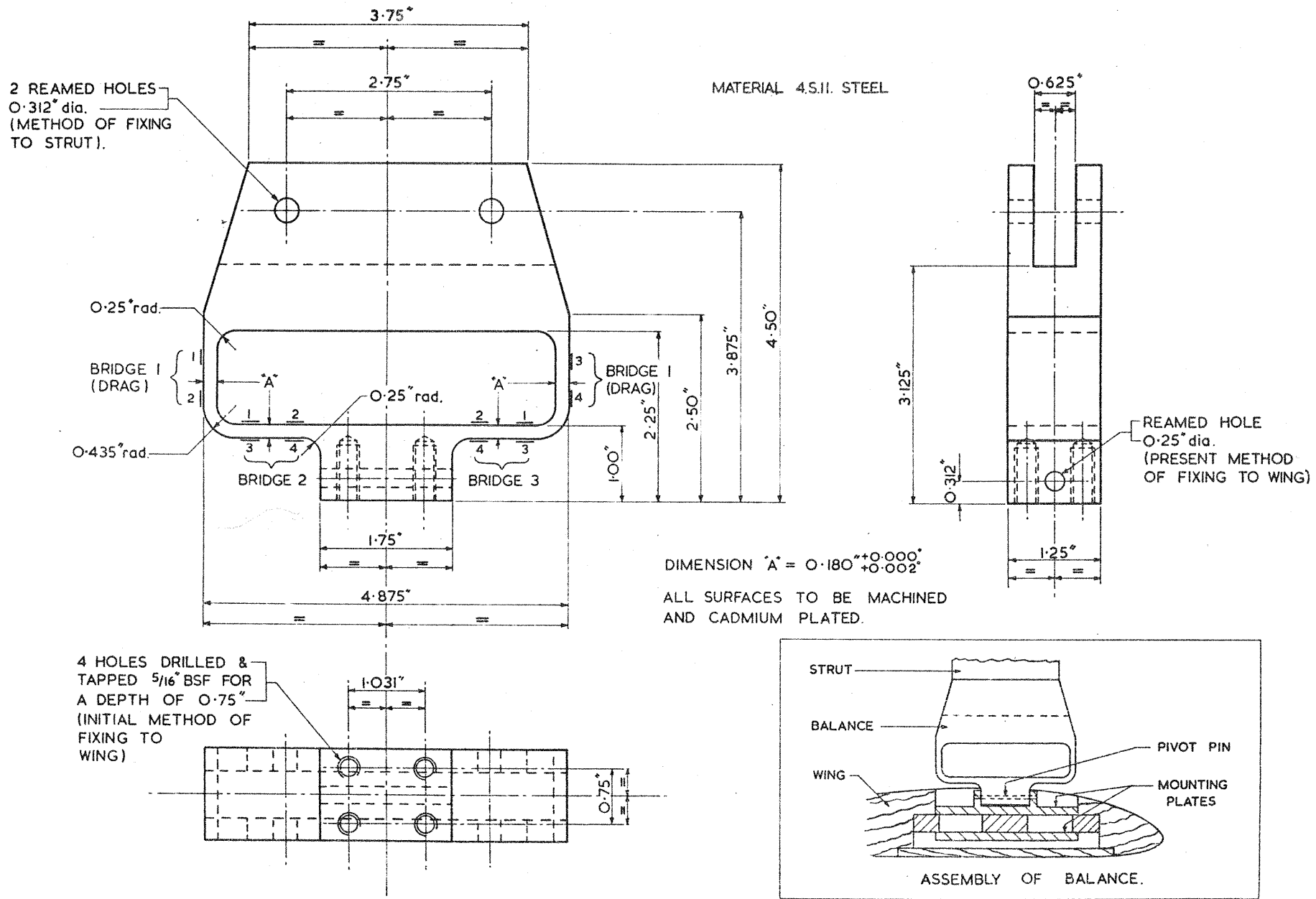
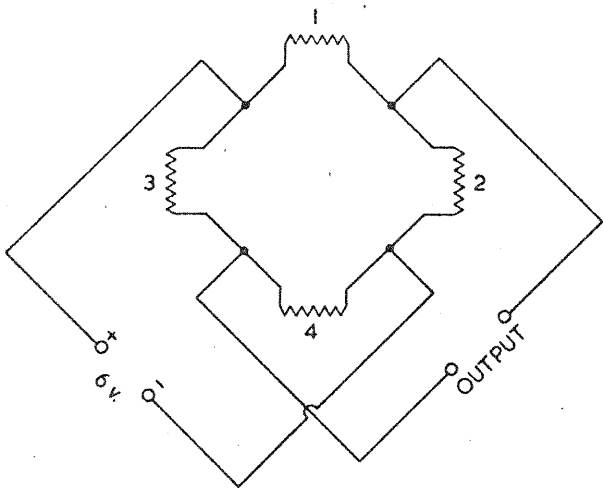

FIG. 12.(a) STRAIN GAUGE BALANCE Mk.II.

BRIDGE 1 (DRAG)



BRIDGES 2 & 3 ARE IDENTICAL TO BRIDGE 1.

FIG. 12.(b). CIRCUIT USED FOR STRAIN GAUGE BRIDGES.

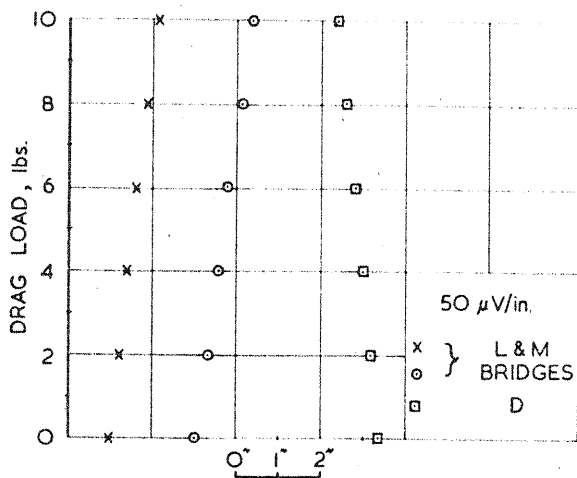

FIG. 13 a. DRAG CALIBRATION OF NEW BALANCE

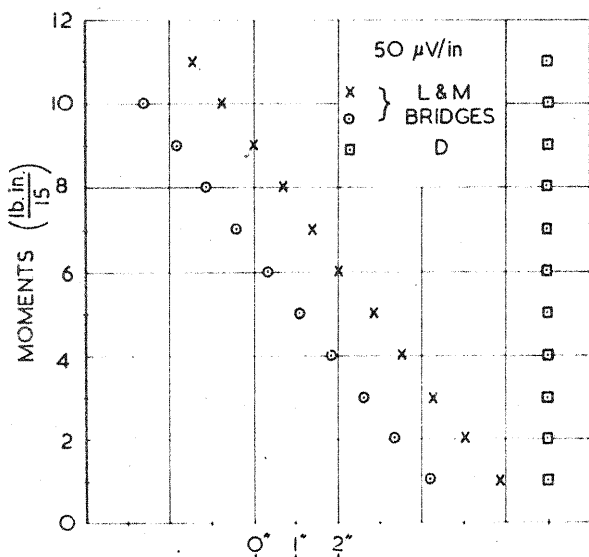

FIG. 13 b. EFFECT OF 15 lb. LIFT ACTING AT VARIOUS CHORDWISE STATIONS.

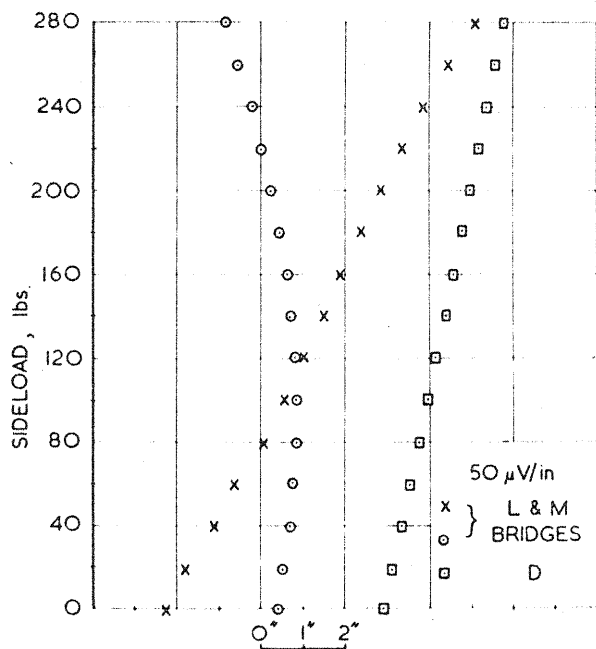

FIG. 13 c. EFFECT OF SIDELOAD ON BRIDGE ZEROES.

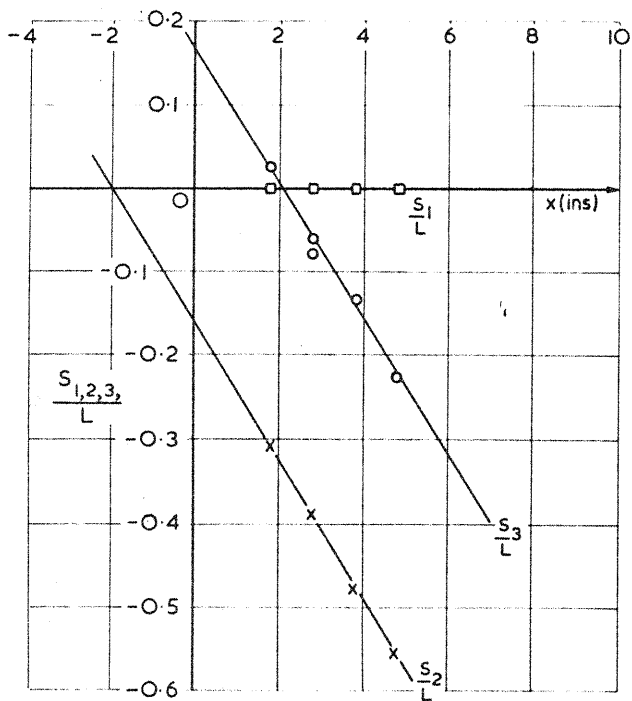

FIG. 14 (a). CALIBRATION DUE TO LIFT LOADS (BALANCE No.1)

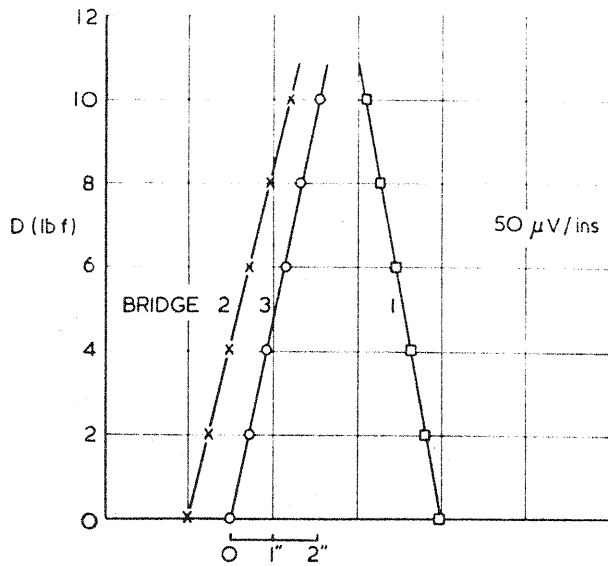

FIG. 14 (b). CALIBRATION DUE TO DRAG LOADS (BALANCE No.1)

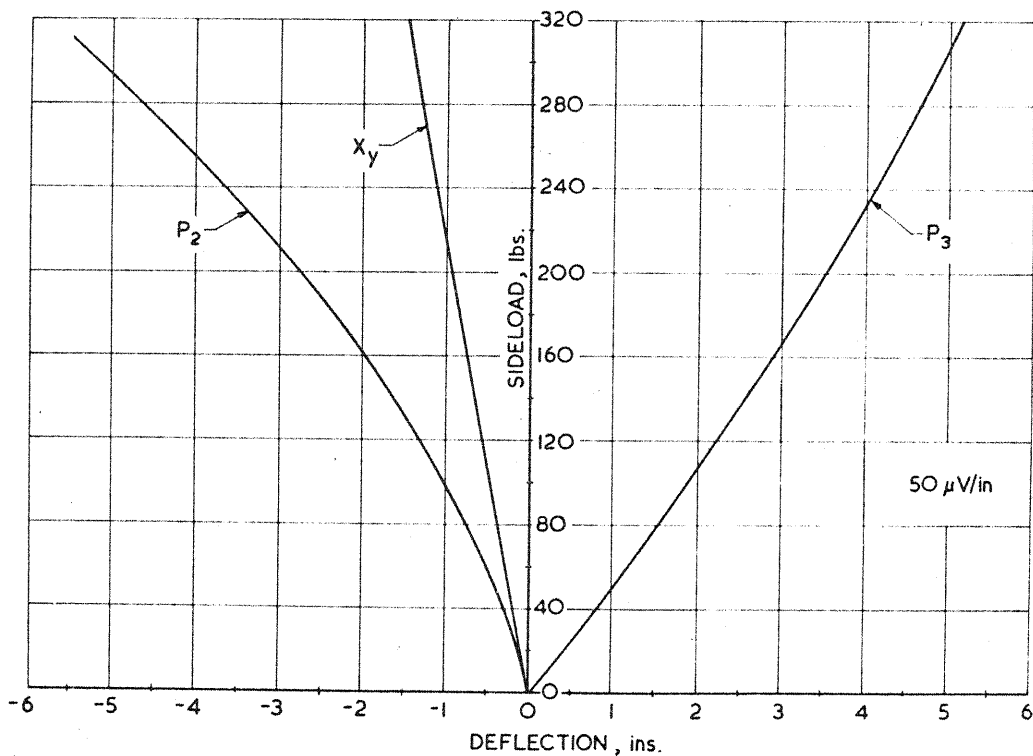

FIG. 14 (c) BALANCE No. 1.

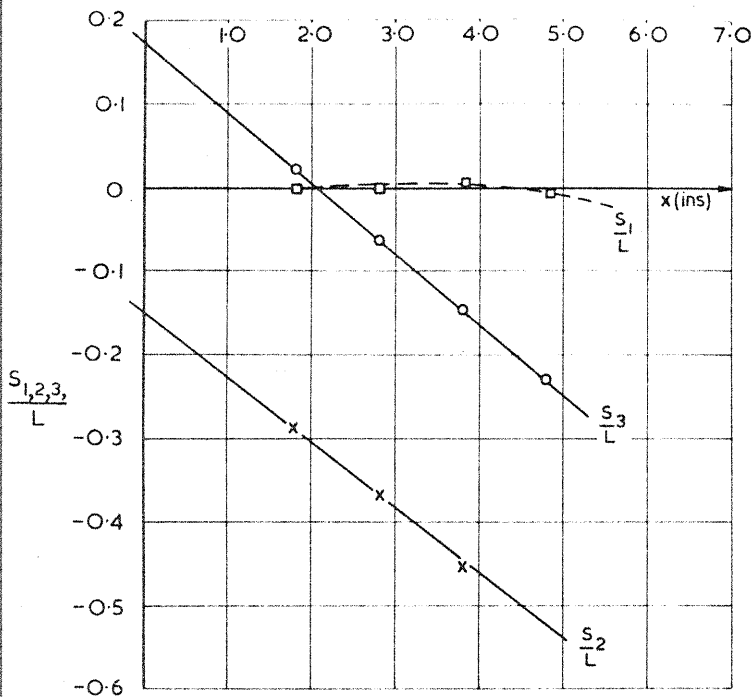

FIG. 15(a). CALIBRATION DUE TO LIFT LOADS (BALANCE No. 2)

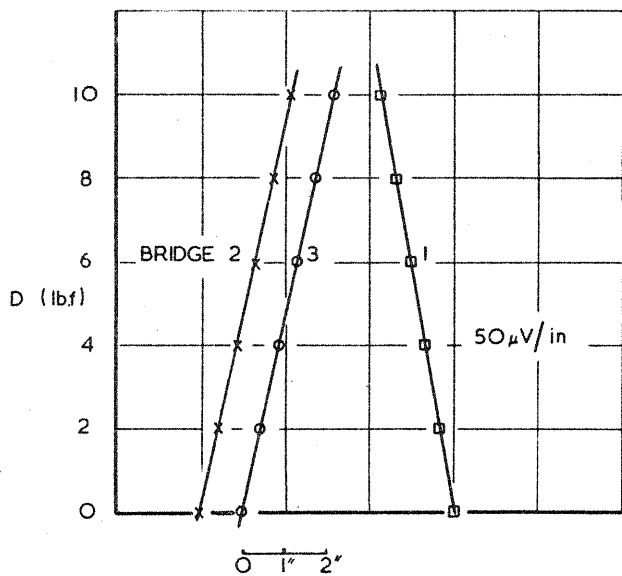

FIG. 15(b). CALIBRATION DUE TO DRAG LOADS (BALANCE No. 2)

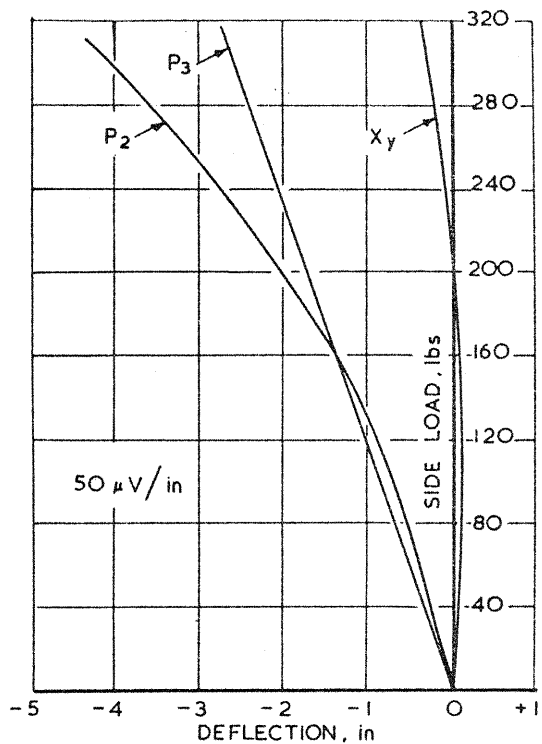

FIG. 15(d). BALANCE No. 2

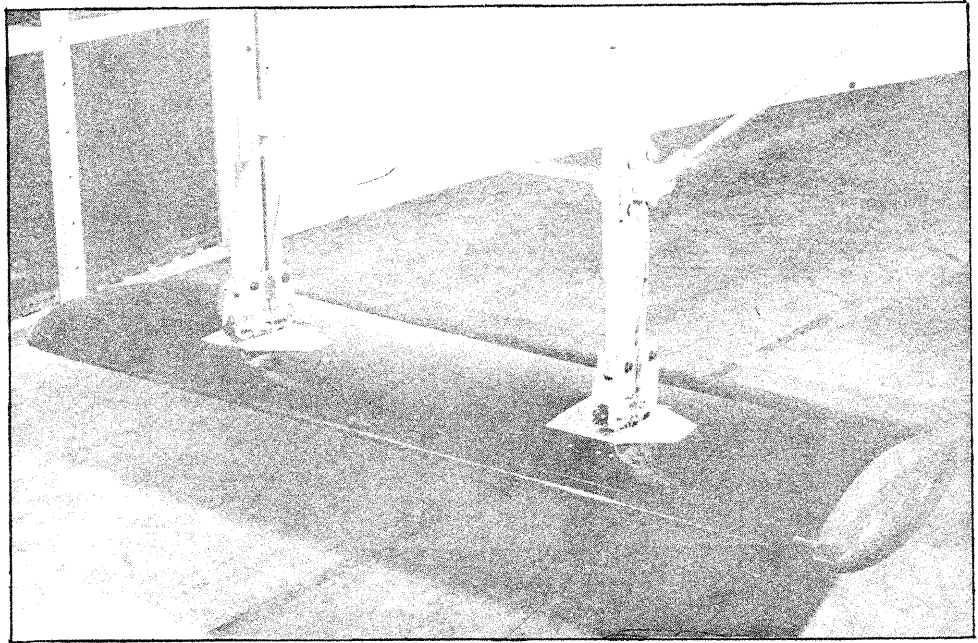

FIG. 16 MK. 2 BALANCES ON THE WHIRLING ARM

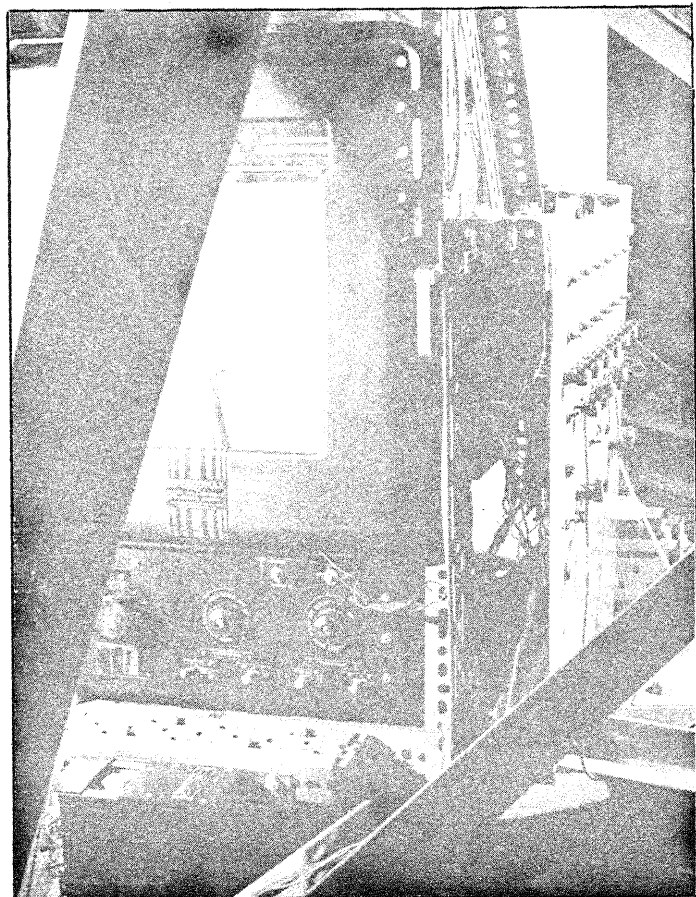

FIG. 17 "SPEEDOMAX" RECORDER MOUNTED ON THE WHIRLING ARM



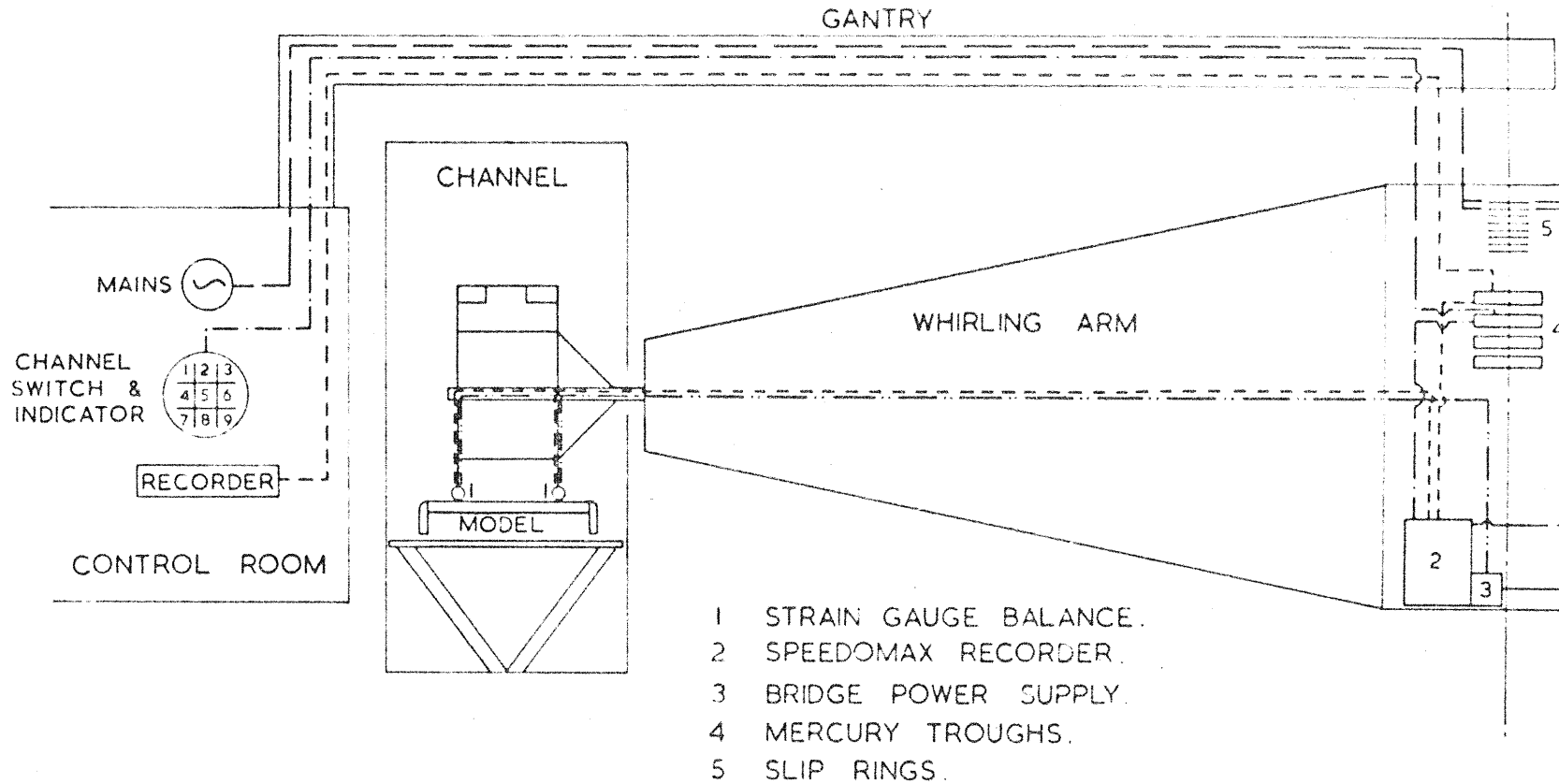

FIG.18. SCHEMATIC LAYOUT OF METHOD OF TRANSMITTING SIGNALS FROM THE STRAIN-GAUGE BALANCES TO THE CONTROL ROOM.

(THIS METHOD IS TO BE ALTERED IN THE FUTURE).