

Review of More Electric Engines for Civil Aircraft

Yixiong Liu¹

AECC Shenyang Engine Research Institute, Shenyang, China

Da Mo²

AECC Shenyang Engine Research Institute, Shenyang, China

Devaiah Nalianda³

Centre for Propulsion Engineering, School of Aerospace, Transport and Manufacturing, Cranfield University, Bedfordshire, MK43 0AL, United Kingdom

Yiguang Li⁴

Centre for Propulsion Engineering, School of Aerospace, Transport and Manufacturing, Cranfield University, Bedfordshire, MK43 0AL, United Kingdom

Ioannis Roumeliotis⁵

Centre for Propulsion Engineering, School of Aerospace, Transport and Manufacturing, Cranfield University, Bedfordshire, MK43 0AL, United Kingdom

Abstract

More electric engines (MEEs) and more electric aircraft (MEA) are mainly implemented to address the global warming issue and make engines more fuel efficient. Developing technology has made them applicable. This paper presents a detailed introduction to the MEE for civil aircraft, including its architecture, characteristics and performance, as well as the potential benefits of fuel consumption and emissions reduction. It is obvious that the adoption of electric components, such as active magnet bearings, electric starters and generators and electric fuel pumps, is beneficial. It is especially

¹ Senior Engineer

² Senior Engineer, Corresponding author: dada1204@126.com

³ Senior Lecturer

⁴ Reader

⁵ Senior Lecturer

advantageous when mechanical, hydraulic and pneumatic systems with great weight and complex structures are eliminated. Moreover, the exploration of electric propulsion systems indicates that the potential profits are large and tempting. The challenges and technology bottlenecks for MEEs are also discussed. With the further development of battery and motor technology, the MEE will undoubtedly play a dominant role in the civil aircraft market.

Key words: More electric engine, More electric aircraft, Electric components, Electric propulsion system, Civil aircraft

1. Introduction

Civil aviation has seen a soaring increase in recent years, which is greatly attributed to rapidly developing economies, prosperous tourism and close international cooperation, as shown in **Fig. 1** [1]. This has encouraged the aviation industry and upset environmental protection groups because if more aircraft are put into use, more fossil fuel is consumed, which would produce unacceptable amounts of emissions such as carbon dioxide (CO₂) and nitrogen oxide (NO_x). According to Reference [2], the CO₂ emitted by aircraft reached 2% of total CO₂ emissions in 2008. As global warming is becoming a worldwide concern, the Advisory Council for Aviation Research and Innovation in Europe (ACARE) fully understood the issue and set a short-term goal for the aviation industry of reducing CO₂ and nitrogen dioxide emissions by 50% and 80%, respectively, by 2020. Moreover, further reductions of 25% and 10% are required for CO₂ and NO_x by 2050 as a long-term task [2]. A summary of emission target goals for the industry is shown in **Fig. 2** [2][3].

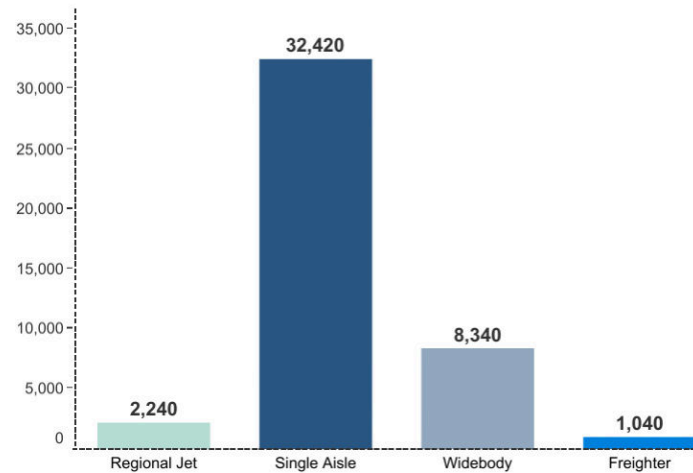

Fig. 1 Boeing deliveries in 2019 [1]

CO ₂ -Emission		Vision 2020	SRIA 2020	SRIA 2035	SRIA 2050
Air Traffic per passenger kilometer		-50%	-43%	-60%	-75%
Contribution	Airframe	-25%	-20%	-30%	-68%
	Engine	-20%	-20%	-30%	
	Air traffic management	-12%	-7%	-12%	-12%
	Operation	-4%	-4%	-7%	-12%
NO _x -Emission		Vision 2020		SRIA 2035	SRIA 2050
Air traffic per passenger kilometer		-80%		-84%	-90%
Margin rel. ICAO LTO CAEP6		-60%		-65%	-75%
Noise-Emission		Vision 2020		SRIA 2035	SRIA 2050
Aircraft		-10 EPNdB		-11 EPNdB	-15 EPNdB

Fig. 2 Emission reduction goals [2][3]

In fact, manufacturers are dedicated to seeking solutions to burn less fuel not only because of environmental issues but also because of economic benefits. First, the concepts of more electric aircraft (MEA) and more electric engines (MEEs) were developed simply to replace the secondary power systems in hydraulic, pneumatic and mechanical systems with electric systems. In a conventional aircraft, hydraulic power is mostly used to drive landing gear, retraction, braking and engine actuation. Although it is robust and has a higher power density, its drawbacks of heavy weight, higher leakage possibility and large-scale size outweigh its advantages. The pneumatic power system extracts energy from the bleed air and mainly serves the environment control system and anti-ice system. However, air bleeding comes at the expense of making the gas turbine engine less efficient with lower thermal efficiency, and it worsens the specific fuel consumption (SFC). In regard to the mechanical system, the part of greatest concern is the gearbox, which transports the power from the power source to the components. Its disadvantages are obvious; for example, the transmission efficiency needs to be taken into consideration because of friction. Additionally, the bearing wear and extra cooling oil contribute to the unsatisfactory performance. Then, the electric power system appeared in the 1940s [4], and it began

to be treated as a source for the secondary power system. In fact, the introduction of electric power has simplified the aircraft internal structure and engine configuration by eliminating the extraction of air from the compressor, removing the drive gearbox and replacing the lubricating oil system. The engine is more efficient since there is little or no bleed air, which can improve SFC and reduce fuel consumption. Currently, electric power can be utilized for actuation systems, ice protection systems, control systems and fuel pumping [5]. The accomplishment of MEA depends greatly on MEE technology, including active magnetic bearing (AMB) systems, actuation systems, actuators, generators, and distributed control systems, which are the primary parts of MEEs. Numerous investigations have been conducted on the MEE. In fact, the most successful cases of electric power application are the Boeing 787 and Airbus 380, which mount more electrical systems than any other previous planes [4][6]. For example, the A380 partially equips its flight control actuators with electric power [7]. Moreover, the B787's environmental control system and ice protection system have been taken over by electric systems [8], thus eliminating the bleeding air system, improving the engine efficiency and reducing fuel consumption. Comparisons between MEEs and traditional systems are depicted in **Fig. 3** [9].

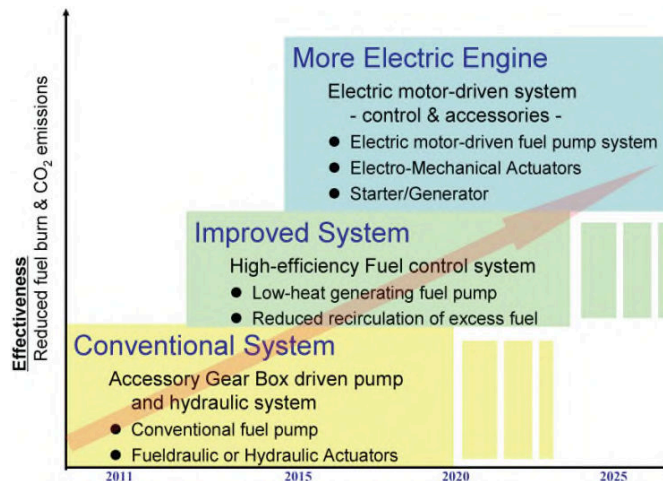

Fig. 3 MEE and traditional system comparison [9]

From the perspective of improving fuel efficiency, the most effective approach is to refine the propulsion system or the gas turbine (GT) that provides thrust for aircraft takeoff, climbing and cruising. Although the geared turbofan (GTF) engine proved to be an effective measure to improve propulsive efficiency and curb emissions [10], researchers around the world are attempting to find a way to implement electric power for conventional GTs. Six types of electric propulsion systems combining

electric trains and conventional GTs were proposed by NASA [11]. There have been several explorations of electric engine development. Boeing super ultra green aircraft research (SUGAR) would benefit from the parallel hybrid electric engine, which is predicted to cut back the fuel flow and reduce SFC by up to 75% under cruise conditions; see **Fig. 4** [12]. NASA N3X and Airbus General Aviation are also examples of exploring the usage of electric propulsion systems, as shown in **Fig. 5** [11]. The benefits are obvious and dramatic: on-board fuel consumption is lower and emissions are correspondingly lower.



Fig. 4 Boeing SUGAR aircraft [12]



Fig. 5 NASA N3X aircraft [11]

This paper first introduces the key components and electric propulsion system of the MEE. Then, overall performance improvements of the MEE are discussed, as well as the economic and environmental benefits. In addition, the evolution of technologies and possible challenges for the MEE are described. Moreover, applications of the MEE and their future development are highlighted. Finally, conclusions summarizing all the key points of the MEE for civil aircraft are obtained.

2. Architecture of the MEE

As mentioned above, the main components of MEA and MEEs include AMBs, flight control systems (FCSs), environmental control systems (ECSs), distributed control systems (DCSs), ice protection systems (IPSs), electric fuel pumps (EFPs), electric starters/generators (SGs) and electric actuators

(EAs). The typical no-bleed engine configuration can be seen in **Fig. 6**. The energy generated by the GT is transported to generators and then supplies electric power for the actuators, starters, air conditioning system, icing protection system, cabin pressurization, fuel pumping and so on.

This chapter not only describes the details of the AMB, SG, EA and EFP but also covers the electric propulsion system.

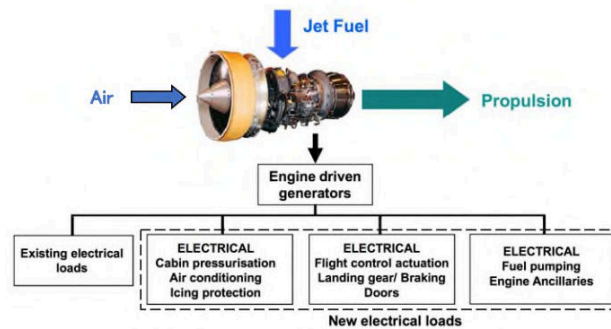

Fig. 6 No-bleed engine architecture of the MEA [5]

2.1 Active Magnetic Bearing

The bearing system plays a crucial role in maintaining the engine shaft, rotors and stators. The working condition of roll and ball bearings for the conventional GT is harsh, with high temperatures, high rotation speeds, and complex cooling and sealing requirements. Besides, the bearings support high-pressure components and low-pressure components. Therefore, the complexity and weight as well as the maintenance cost are tremendous. Then, the concept of AMBs is adopted, which takes advantage of magnetic suspension theory and uses electromagnetic force to separate the rotor and stator. The architecture of the AMB system is shown in **Fig. 7**, consisting of electromagnetic bearings, gap sensors, a controller and a power amplifier [13][14]. The working theory is that the system utilizes noncontact gap sensors to monitor the shaft dynamics, such as the accelerated velocity and vibration amplitude, and then transmits the signal through the controller to make comparisons with the desired values. If they do not match, power adjustment commands are sent, and adjustment is performed by the electromagnetic bearing via the power amplifier.

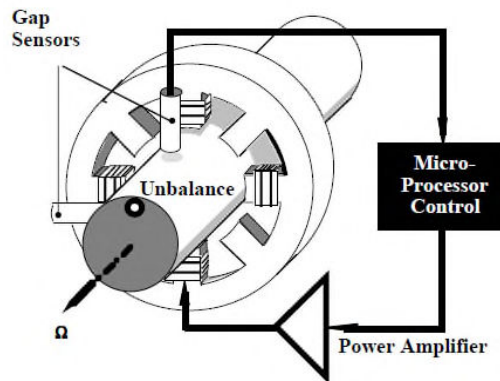
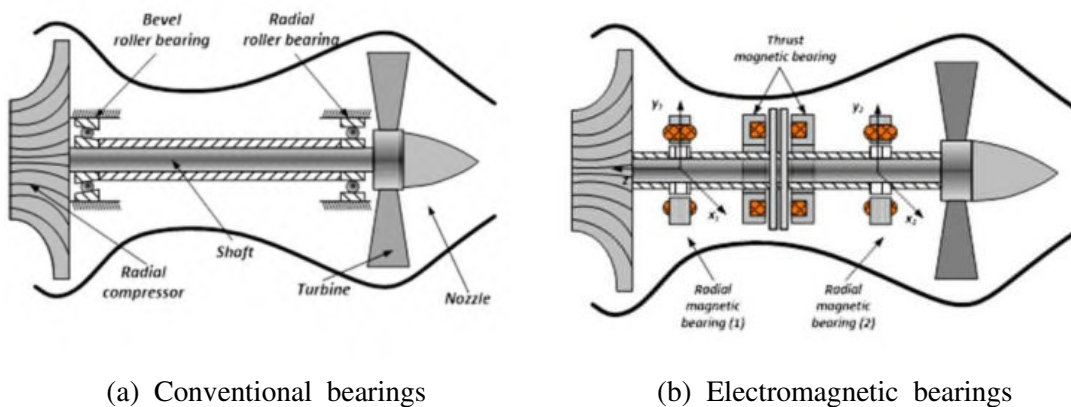

Fig. 7 Architecture of the AMB system [14]

A comparison between the conventional bearing system and the AMB system is shown in **Fig. 8**. The electromagnetic bearings eliminate the physical connection between them, thus eliminating the oil system and reducing friction losses as well as weight penalties. Moreover, since the AMB system is under the supervision of the active control system, it can actively indicate the shaft dynamics during engine operation, which provides a good way to monitor, analyze and diagnose issues in the whole engine.



(a) Conventional bearings

(b) Electromagnetic bearings

Fig. 8 Comparison between conventional bearings and AMBs [15]

2.2 Electric Starter/Generator

The electric SG for the MEE has two different uses. The SG first starts the engine and assists it at idling speed. After that, it becomes a generator, which converts the engine shaft power into electricity and supplies the other electric systems of the MEA. Currently, three kinds of SG systems are commonly employed in the aviation industry. They are the three-phase, brushless, synchronous SG, the switched reluctance SG, and the permanent magnet SG [16]. **Fig. 9** shows the electric SG. For the first type of SG, the second stage excites the first stage via a diode rectifier, and the third stage receives excitation from the permanent magnets; therefore, the system is self-sustaining and can output power at a wide

range of frequencies. Additionally, it has a noncontact brush, featuring high reliability and durability, and is well accepted in the industry [17]. Switched reluctance SGs can be operated under fault conditions [18] and endure higher speed and worse working conditions with relatively high power density. Finally, the permanent magnet generator is thought to be ideal for the MEE because of its high reliability, durability, and power-to-weight ratio [19]. In addition, it suits the distributed propulsion system well.

The increasing demands for electricity on board exceed the ability of traditional constant-speed constant-frequency systems (CSCFs). Therefore, as a promising alternative, the variable-speed constant-frequency (VSCF) system has emerged, which removes the constant-speed drive (CSD). VSCF will prove itself as a better solution for SGs in the near future.

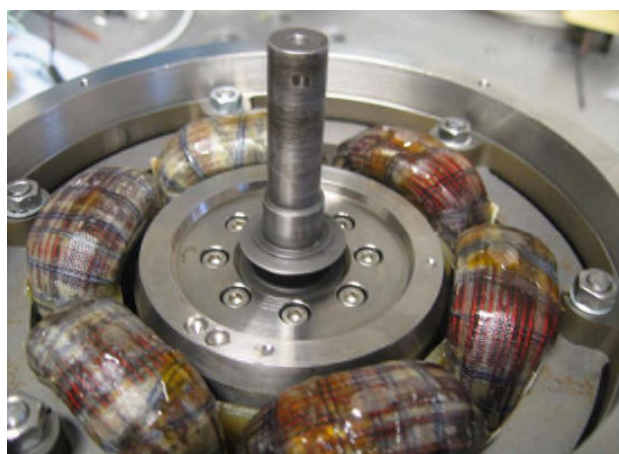

Fig. 9 An electric SG [20]

2.3 Electric Actuator

Electric actuation has made fault detection easier since there are an increasing number of electric components mounted in the engine and aircraft. As shown in **Fig. 10**, electrohydrostatic actuators (EHAs) and electromechanical actuators (EMAs) are the most common electric actuators [21]. For the EHA, the electric motor provides pressure and actuates the hydraulic system, which is connected to a pump. For the EMA, the motor is linked to a gearbox and a ballscrew, and the power from the electric motor is then converted to the actuator's motion. Undoubtedly, the EMA possesses the merits of a low weight and simplified structure, which are important for MEE design. In addition, the attrition rate and degradation can be detected by the control system. Kang [22] proposed a dynamic power consumption estimation method for the primary and secondary control surface EMAs. Furthermore, both the

numerical simulation and flight test validation were carried out to uncover the advantages of EMAs.

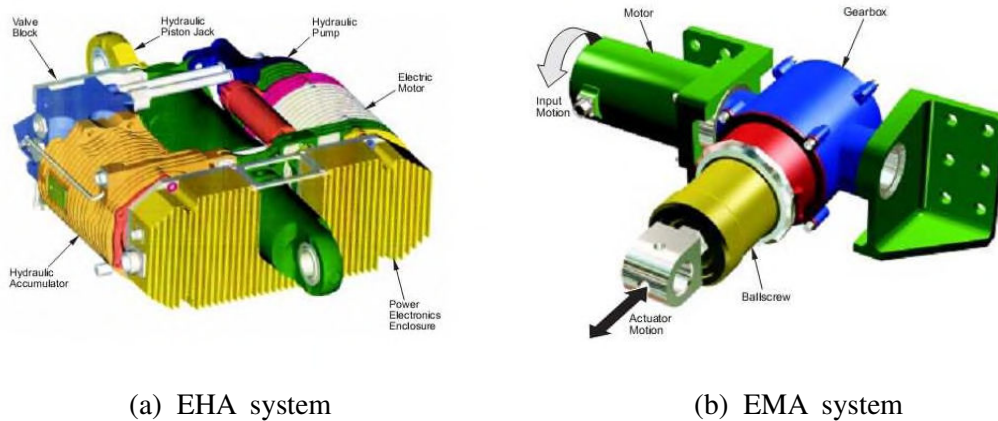
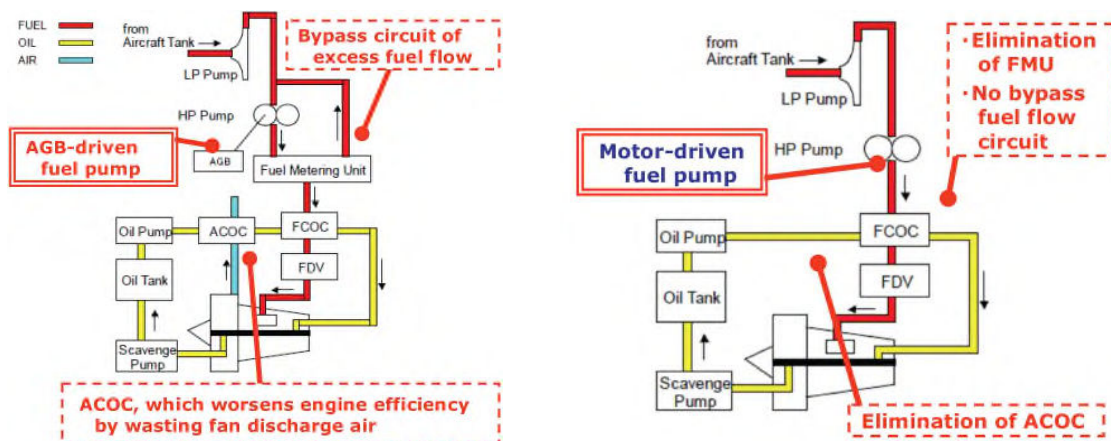

Fig. 10 EHA and EMA [21]

2.4 Electric Fuel and Oil System

The fuel system is an important component since it provides all the fuel needed to boost the engine and keep the engine working. The conventional fuel system is comprised of a fuel tank, fuel metering unit, and fuel pump connected to the accessory gearbox (AGB), as shown in **Fig. 11**. If the engine accelerates, there is an increased fuel requirement, and then the AGB drives the fuel from the tank to the pump. The fuel flow is determined by the metering unit. The excess fuel returns from the bypass circuit via valves to the fuel tank, with a reduction in efficiency and an increase in fuel temperature. However, the electric fuel system eliminates the AGB, metering unit, bypass valves, and air-cooled oil cooler, making it possible to reduce weight and improve oil heat management and system efficiency [9]. These goals are achieved by utilizing a motor-driven fuel pump, fuel pressurizing valve and pressure sensors. According to [9], the cruise SFC and total flight mission block fuel enjoy an approximate 1% reduction by applying the electric fuel system, as shown in **Fig. 12**.



(a) Traditional fuel system

(b) Electric fuel system

Fig. 11 Configuration of the fuel pump system [9]

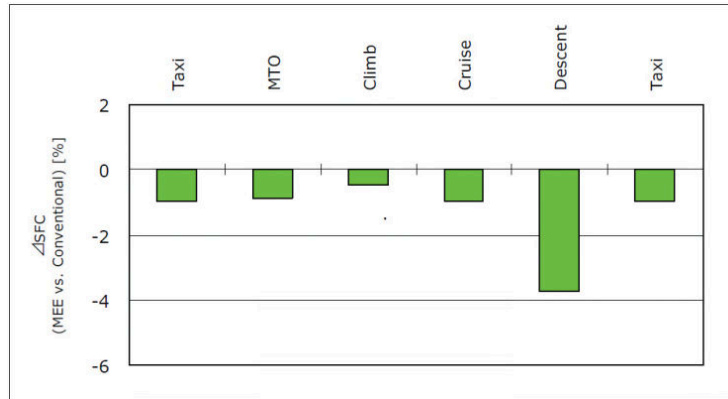

Fig. 12 SFC improvement for the MEE [9]

2.5 Electric Propulsion System

In addition to the electric components discussed above, in recent years, there has been an increasing demand for propulsion systems to be electrified. The electric energy derived from the battery or engine becomes the source that drives the fan.

2.5.1 Series hybrid electric propulsion system

Fig. 13 shows a typical series hybrid electric propulsion system (SHEPS). The GT engine is linked to the motor drive, which is mechanically linked to the fans. The GT is utilized to boost the motors, and then the fuel energy is converted to electricity, which boosts the fan to produce thrust. The on-board battery could also be an alternative energy source. The concept of the SHEPS is suitable for distributed propulsion systems and turbopropellers.

However, since there are some losses during the battery discharge process, not all the output power of the GT or battery pack is fully utilized. Normally, for current state-of-the-art systems, the motor and battery efficiencies are 0.92 and 0.95, respectively, and the motor specific power and battery specific energy are approximately 5 kW/kg and 200 W-hr/kg [23], indicating that there is too much loss in the SHEPS. The drawbacks of the battery pack weight might offset its SFC improvement simply because the electric power has to be equal to the fuel energy, which is an enormous amount of power with an unacceptable battery or motor weight penalty.

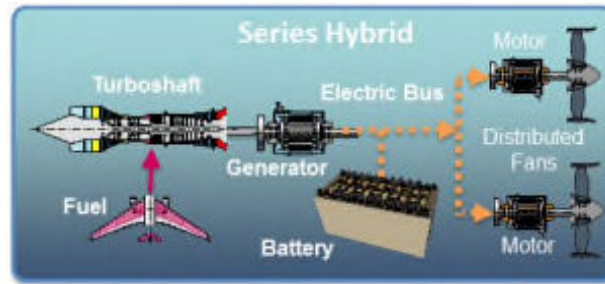

Fig. 13 Series hybrid electric propulsion system [11]

2.5.2 Parallel hybrid electric propulsion system

Fig. 14 shows the configuration of the parallel hybrid electric propulsion system (PHEPS). The most obvious difference between the SHEPS and PHEPS is that the GT and electric engine are connected to the fan and supply power of the PHEPS. This makes the PHEPS more flexible and could avoid the battery and motor weight penalty since not too much energy is needed from the electric engine.

For this kind of configuration, there are two strategies of employing electric power. The first method is to use electric power to make up for thrust-demanding segments, such as the takeoff (TO) and top of climb (ToC) phases [24]. In this case, the engine could be sized at its optimum performance point, and the engine size might be reduced. Moreover, the turbine blade stress and life cycle could greatly benefit from the decreased turbine entry temperature (TET), SFC, block fuel and emissions improvements. However, there is a potential risk that cannot be ignored. In the case of an emergency, the battery may not function properly when the whole engine power is needed for safety purposes. This could also be a barrier to engine certification.

The other strategy is to carefully split the conventional engine power and the electric power over the whole flight envelope to take full advantage of the hybrid engine. Thus, the conventional GT is still designed for the maximum power requirement segment, although it is slightly heavier than the engine mentioned in the first method. However, the weight reduction from the electric engine could compensate for this.

In summary, the flexibility and operability of the PHEPS have provided engine manufacturers with an opportunity to explore and design a hybrid engine to save money and reduce toxic exhaust gases. Series/parallel hybrid electric propulsion would clearly combine the SHEPS and PHEPS and could also be a good choice for the MEE.

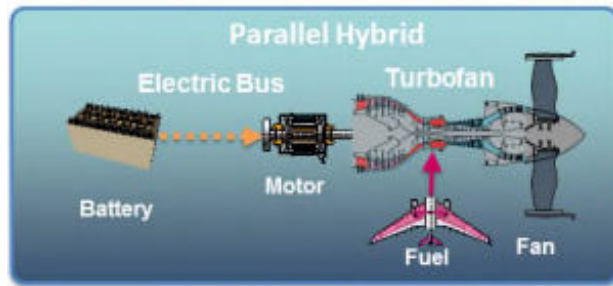
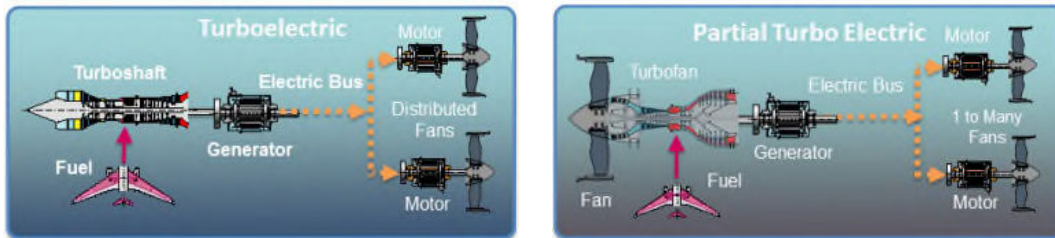

Fig. 14 Parallel hybrid electric propulsion system [11]

2.5.3 Turboelectric propulsion system

A turboelectric propulsion system (TEPS) does not require a battery pack for propulsive power, so the weight of the electric engine is dramatically decreased. Consequently, it is no longer confined by battery technology, as shown in **Fig. 15**. For the full TEPS, all the output power from the GT is converted into electric power and drives the individually distributed fan with the motor. The partial TEPS has two sources of engine power, i.e., the gas turbine and electric engine, although the energy of the electric engine comes from the gas turbine. The advantage of this configuration is that it is much easier for the electric engine to transfer energy to the distributed fans. According to [11], the TEPS has been identified as the most feasible electric propulsion system entering service within the next one to three decades.



(a) Turboelectric engine

(b) Partial turboelectric engine

Fig. 15 Turboelectric propulsion system [11]

2.5.4 All-electric propulsion system

Fig. 16 demonstrates the conceptual design of the all-electric propulsion system (AEPS). Clearly, as a very ambitious design, the AEPS is predicted to be available only on small aircraft because of the large battery mass. As a consequence, relatively little emission is achieved. From this perspective, unmanned and commuter aircraft would be good choices for the AEPS. For example, Byun utilized the electric-powered UAV for thrust control loop design [25]. Considering the technological limitations, there is still a long way to go for the AEPS to enter civil aircraft market.

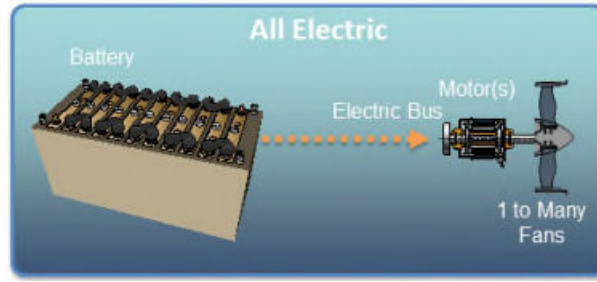

Fig. 16 All-electric propulsion system [11]

3 Performance of the MEE

The profits of utilizing so many electric components together in the engine are difficult to estimate; therefore, for the electric components, the main advantages are weight, efficiency, durability and operability. However, from the perspective of the fuel consumption and emissions of the whole flight mission, it would be better to understand the benefits that electric propulsion systems bring.

3.1 Flight Mission Profile for Civil Aircraft

First, a typical flight mission profile for civil aircraft is plotted in **Fig. 17**. There are three main parts, of which the trip fuel part is the most important. It can be divided into a few segments, such as taxiing out, takeoff, climb, cruise, descent, land, and taxiing in. Among them, the maximum TET always occurs at takeoff, while the ToC is power demanding, and the cruise segment burns the highest amount of fuel.

Regarding diversions, more stored fuel than the fuel to be consumed is prepared on board in case the plane cannot arrive at the planned airport or must travel to an alternative airport. Additionally, reserve fuel must be taken into consideration to cope with unpredictable emergency conditions.

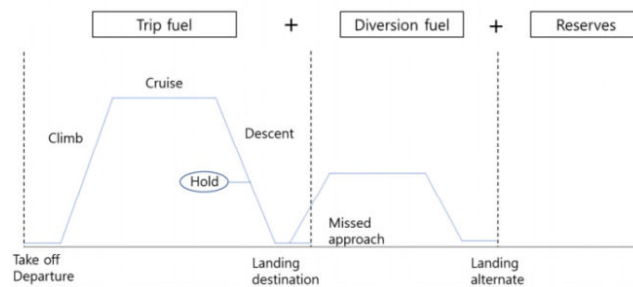

Fig. 17 Typical flight mission profile for civil aircraft [26]

3.2 Benefits of Electric Components

There are numerous studies on the benefits of utilizing electric components. The most common characteristics of these parts are that they reduce the weight and simplify the structure, making fuel efficiency and maintenance much easier. For the AMB, its ability to endure high temperature and high

speed is vital, and it can operate in environments of 600 °C and 50000 rpm [27]. Reference [28] shows that the electric SG system can start the engine at a rate of 55% in no more than 40 s and that the stator current is 20% less than the nominal value. Reference [29] reveals that the reluctance switch SG can perform a 15-second engine starting procedure from 0 rpm to 25000 rpm with a system efficiency exceeding 80% over most of the working speed range. In regard to EA, Reference [21] sets 737-800 as the baseline to investigate the EHA and EMA system and finds that the hybrid EHA system enjoys a 9% weight reduction compared to the all-EHA system. Reference [9] compares the EFP and conventional fuel pump systems and finds that the SFC at cruise and during the mission dropped by 1% each by implementing the EFP system.

3.3 Benefits of Electric Propulsion Systems

3.3.1 Engine Sizing

In the previous section, strategies to add electric power to conventional GTs were discussed. However, for series hybrid, turboelectric and all-electric engines, there seems to be no good way to minimize the size of the engine due to the battery weight penalty. Regarding the parallel hybrid and partial turboelectric engines, since the conventional GT is also part of the energy source, the power split or thrust split could be investigated to balance the GT weight and battery weight.

Reference [23] designed the conventional geared turbofan (cGTF) and hybrid geared turbofan (hGTF) engines. The cGTF is based on the SUGAR aircraft, while the hGTF is sized according to the T4 limit, and the core size of the hGTF has decreased by 17% compared to its competitor. Reference [30] shows a 50% weight reduction in the core engine, which is sized to cruise conditions. The problem is that the takeoff weight increases by at least 10% for a short-range mission. Hence, it is necessary to size the engine properly from a trade-off perspective.

3.3.2 Performance

For a conventional gas turbine, SFC is an appropriate parameter to assess the engine, but for the electric system, it would be better to calculate the thrust specific power consumption (TSPC) [31], as shown in Equation 1. This indicates the power provided by the core GT and electric engine compared to the net thrust and incorporates the effects of the electric energy consumed.

$$TSPC = \frac{P_{Supply}}{F} = \frac{P_{Fuel} + P_{Battery}}{F} \quad (1)$$

However, when electric energy is injected, the steady point performance always moves toward peak efficiency, meaning that the system is more efficient if the battery weight penalty is neglected. Thus, another important and effective way to evaluate aircraft performance is to adopt the concept of the energy specific aircraft range (ESAR) [31], which is related to the flight range and energy consumed.

$$ESAR = \frac{dR}{dE} = \frac{V \times \frac{L}{D}}{TSPC \times W} \quad (2)$$

In Equation 2, V is the airplane flight speed, L/D is the lift/drag coefficient, and W is the airplane weight.

Additionally, block fuel consumption and economic cost comparisons would be a good choice. Reference [26] conducted a thorough investigation of a hybrid electric engine by setting up six cases with different electric power injection plans in different segments with a Rolls-Royce Ultrafan as the baseline engine. Both long-range and short-range flights, 3500 km and 900 km respectively, were simulated to search for the optimal design. The results showed that when electric power is injected at the TO, climb, and descent segments, the fuel saved is 0.4% and 5.66% for the 3500 km and 900 km flight missions, respectively, while the energy consumption is reduced by 2.6% and increased by 0.7% for the 900 km and 3500 km flight missions, respectively. This comparison reveals that it is beneficial to apply electric engines for short-range missions with current technology. For long-range travel, it is better to wait for a breakthrough in battery technology. Moreover, Reference [30] analyzed a parallel hybrid electric engine combined with turboprop. The mission concept of operation (CoO) for 250 km incorporated electric power at the TO and climb, which resulted in 30% and 25% reductions in fuel and energy costs, respectively. This reference assumes battery specific energy deploying 2030 technology. A comprehensive research regarding optimization of the hybrid electric propulsion system for A320-type aircraft revealed that the optimum flight range for the PHEPS was about 600 nm with 12.55% fuel reduction [32]. More importantly, it uncovered that further benefits would be achieved with the battery technology development.

3.4 Emissions

CO₂, NO_x, and noise, which are the most concerning exhaust outcomes of the GT, have been strictly regulated by the International Civil Aviation Organization (ICAO). The introduction of MEEs could dramatically reduce emission problems, especially carbon dioxide and noise issues. CO₂ contributes most to global warming because of its strong ability to absorb heat from the sun and reradiate it to the environment. In fact, the CO₂ produced by the GT could simply be connected to the fuel burn. More fuel means a greater chemical reaction in the combustor. Fortunately, fuel is reduced when electric power is injected, so CO₂ emissions could be reduced to some extent.

For mitigating noise disturbance, the electric propulsion system claims little effect since the noise of SUGAR VOLT is only 1 EPNdB lower than that of SUGAR HIGH [12]. Reference [33] estimated the noise level by comparing a 1 MW motor application with a lower fan pressure ratio, although the results were not optimistic. However, this does not mean that electric power has no potential to decrease noise emissions. On the contrary, electric power has made it possible to design engines with a higher bypass ratio (BPR). Additionally, less power is needed from the core GT, resulting in a smaller engine size and making the fan noise lower than that of the conventional GT. In addition, as the enthalpy drop across the low-pressure turbine (LPT) blades also decreases, the exhaust velocity could be lowered, and the noise would decrease. N3X is said to be 64 EPNdB quieter than the current architecture [34]. Since CO₂ and noise regulations could be even more stringent in the future, there is an urgent need to explore the redesign of engines considering electric energy.

4 Challenges and Future Development

Before moving to the conclusions, some challenges facing the MEE and its future development should be stated. There are a few problems that the MEE/MEA has to address in order to embrace a larger market. The first and most important is the weight of the motor and battery. The specific power of the motor and specific energy of the battery are still not high enough to eliminate the weight penalty, especially when the very large power requirement of the electric propulsion system is taken into consideration. In addition, the need for cryocooling might lead to an inefficient motor. Moreover, the life cycle of the battery should also be considered. The second issue that cannot be ignored is safety and

certification. More electric components in the engine mean more unknowns and uncertainty, so it would be difficult to prove that the MEE could satisfy the requirements of legislation. The integration of aircraft and engines should also be considered in order to make the system work in the most efficient way and burn less fuel as well as enable easy maintenance.

However, there is no doubt that the MEE is promising and will be promoted as long as there are breakthroughs in battery and motor technology. Then, it will see a prospering market in the aviation industry, especially for civil aircraft.

5 Conclusions

This paper presents a thorough introduction to the MEE for civil aircraft. The architecture of electric components and electric propulsion systems are depicted with the advantages of utilizing electric assemblies. Afterwards, the benefits of utilizing the MEE are discussed from the perspective of mission fuel consumption and emissions. It is worth mentioning that if the electric propulsion system were accessible, there would be nonnegligible benefits regarding fuel consumption and energy usage. Consequently, the targets of saving money and curbing emission are achieved concurrently. Although there are still some barriers to be overcome, the prospects for the MEE in civil aircraft are excellent.

Declaration of interests

The authors declare that they have no known competing financial interests or personal relationships that could have appeared to influence the work reported in this paper.

Acknowledgement

The authors would like to thank the AECC Shenyang Engine Research Institute for funding and support.

References

- [1] Boeing Commercial Market Outlook 2019-2038, [Online] Available:<http://www.boeing.com/commercial/market/commercial-market-outlook>.
- [2] Advisory Council for Aeronautics Research in Europe. (2010, June). Aeronautics and Air Transport: Beyond Vision 2020 towards 2050 [Online]. Available: <http://www.acare4europe.org/docs/towards2050.pdf>.
- [3] Strategic Research and Innovation Agenda Volume 1. (2012). Advisory Council for Aviation Research and Innovation in Europe. Available: <https://www.acare4europe.org/sites/acare4europe.org/files/document/ACARE-Strategic-Research-Innovation-Volume-1.pdf>.
- [4] Yi tao Liu, Junxiang Deng, Chao Liu, etc. (2018). Energy optimization analysis of the more electric aircraft. IOP Conference Series: Earth and Environment Science, 113 (2018) 0112152, 1-7. <https://doi.org/10.1088/1755-1315/113/1/012152>
- [5] P. Wheeler. (2016). Technology for the more and all electric aircraft of the future. 2016 IEEE International Conference on Automatica (ICA-ACCA), Curico, 2016, 1-5. <https://doi.org/10.1109/ICA-ACCA.2016.7778519>
- [6] L. Setlak and R. Kowalik. (2017). Modern technological solutions in generation, transmission and distribution of electricity in “conventional” vs. “More Electric” Aircrafts. 2017 Progress in Applied Electrical Engineering (PAEE), Koscielisko, 2017, 1-6, <https://doi.org/10.1109/PAEE.2017.8009008>
- [7] E. Alcorta-Garcia, A. Zolghadri and P. Goupil. (2011). A Nonlinear Observer-Based Strategy for Aircraft Oscillatory Failure Detection: A380 Case Study. IEEE Transactions on Aerospace and Electronic Systems, 47(4), 2792-2806. <https://doi.org/10.1109/TAES.2011.6034665>
- [8] A. Ghodbane, M. Saad, C. Hobeika, J. –. Boland and C. Thibeault. (2016). Design of a tolerant flight control system in response to multiple actuator control signal faults induced by cosmic rays. IEEE Transactions on Aerospace and Electronic Systems, 52(2), 681-697, <https://doi.org/10.1109/TAES.2015.140787>.

- [9] Noriko Morioka, Hitoshi Oyori. (2011). Fuel pump system configuration for the more electric engine. Aerospace Technology Conference and Exposition, 1-10. <https://doi.org/10.4271/2011-01-2563>
- [10] Da Mo.(2021). Conceptual design of a two-shaft high bypass turbofan engine for entry-into-service 2025. Cranfield University, MSc Thesis.
- [11] National Academies of Sciences, Engineering, and Medicine (2016). Commercial aircraft propulsion and energy systems research: reducing global carbon emissions. Washington, DC: The National Academies Press.<https://doi.org/10.17226/23490>
- [12] M. K. Bradley, C. K. Droney. (2015). Subsonic Ultra green aircraft research: phase II – volume II – hybrid electric design exploration, NASA/CR–2015–218704. <https://doi.org/2060/20150017039>
- [13] D. Eaton, J. Rama and S. Singhal. (2010). Magnetic bearing applications & economics. 2010 Record of Conference Papers Industry Applications Society 57th Annual Petroleum and Chemical Industry Conference (PCIC), 1-9, <http://doi.org/10.1109/PCIC.2010.5666819>
- [14] Li sun. (2013). A review of more electric engine technology and the preliminary application to a long range bizjet engine. Cranfield University MSc Thesis. <https://mta.cranfield.ac.uk/handle/1826.1/6695>
- [15] Henzel Maciej, Falkowski Krzysztof, Olejnik Aleksander. (2018). The analysis of “more electric engine” technology to improve the environmental performance of aircraft jet engine. E3S Web of Conferences. 46. 00029. <https://doi.org/10.1051/e3sconf/20184600029>
- [16] Tao Yang, Fei Gao, Serhiy Bozhko, etc. (2018). Power electronic systems for aircraft. Control of Power Electronic Converters and Systems. 2, 333-368. <https://doi.org/10.1016/B978-0-12-816136-4.00025-7>
- [17] M. A. Zharkov and V. E. Sidorov. (2019). Electric Starter System for Launching a Gas Turbine Aircraft Engine. 2019 20th International Conference of Young Specialists on Micro/Nanotechnologies and Electron Devices (EDM), 700-704. <https://doi.org/10.1109/EDM.2019.8823513>

- [18] Song Shoujun, Liu Weigu, Dieter Peitsch, etc. (2010). Detailed design of a high speed switched reluctance starter/generator for more/all electric aircraft. *Chinese Journal of Aeronautics*, 23(2), 216-226. [https://doi.org/10.1016/S1000-9361\(09\)60208-9](https://doi.org/10.1016/S1000-9361(09)60208-9)
- [19] A. J. Mitcham, J. J. A. Cullen. (2002). Permanent magnet generator options for the More Electric Aircraft. 2002 International Conference on Power Electronics, Machines and Drives, 241-245, <https://doi.org/10.1049/cp:20020121>
- [20] B. S. Bhangu and K. Rajashekara. (2011). Control strategy for electric starter generators embedded in gas turbine engine for aerospace applications. 2011 IEEE Energy Conversion Congress and Exposition, Phoenix, AZ, 1461-1467. <https://doi.org/10.1109/ECCE.2011.6063953>.
- [21] Imon Chakraborty, David Trawick, David Jackson, etc. (2013). Electric control surface actuator design optimization and allocation for the more electric aircraft. *AIAA Aviation*, 1-17, <https://doi.org/10.2514/6.2013-4283>.
- [22] Kang, J.G., Kwon, J.Y. & Lee, M.S. A Dynamic Power Consumption Estimation Method of Electro-mechanical Actuator for UAV Modeling and Simulation. *Int. J. Aeronaut. Space Sci.* (2021). <https://doi.org/10.1007/s42405-021-00417-4>
- [23] Charles E.L, Larry W.H, Jonathon R., etc. (2016). Parallel hybrid gas-electric geared turbofan engine conceptual design and benefits analysis. *AIAA* 2016-4610, 1-13. <https://doi.org/10.2514/6.2016-4610>.
- [24] Angel Aymat. (2018). Appropriate aircraft configuration for hybrid electric propulsion. Cranfield University MSc Thesis. <https://mta.cranfield.ac.uk/handle/1826.1/13634>
- [25] Byun, H., Park, S. Thrust Control Loop Design for Electric-Powered UAV. *JASS* 19, 100–110 (2018). <https://doi.org/10.1007/s42405-018-0003-9>
- [26] Jihoon Yang. (2018). Development of performance model for the prediction of trip energy for a generic electric hybrid engine on transport aircraft. Cranfield University MSc Thesis. <https://mta.cranfield.ac.uk/handle/1826.1/13598>.
- [27] Corrigan Robert, Montague Gerald, Jansen Mark etc. (2003). Design and Fabrication of High-Temperature, Radial Magnetic Bearing for Turbomachinery. NASA/TM-2003-212300, ARL-TR-

2954.

- [28] M. A. Zharkov, V. E. Sidorov. (2019). Electric Starter System for Launching a Gas Turbine Aircraft Engine. 20th International Conference of Young Specialists on Micro/Nanotechnologies and Electron Devices (EDM), 700-704. <https://doi.org/10.1109/EDM.2019.8823513>.
- [29] J. Sun, Z. Kuang, H. Wu, S. Wang and G. Ning. (2011). Implementation of a high-speed switched reluctance starter/generator system. International Conference on Electrical Machines and Systems, 1-5, <https://doi.org/10.1109/ICEMS.2011.6073921>
- [30] Todd Spierling, Charles Lents. (2019). Parallel hybrid propulsion system for a regional turboprop: conceptual design and benefits analysis. AIAA 2019-4466, 1-13. <https://doi.org/10.2514/6.2019-4466>
- [31] C. Pornet, C. Gologan, P.C. Vratny, etc. (2015). Methodology for Sizing and Performance Assessment of Hybrid Energy Aircraft. Journal of Aircraft, 52(1), 341-352. <https://doi.org/10.2514/1.C032716>
- [32] Yixiong Liu.(2021). Optimization of hybrid electric propulsion system. Cranfield University, MSc Thesis.
- [33] T. Donateo, A. Ficarella. (2017) Designing a hybrid electric powertrain for an unmanned aircraft with a commercial optimization software, SAE International Journal of Aerospace, 10(1),1-11, <https://doi.org/10.4271/2017-01-9000>
- [34] J.J. Berton, W.J. Haller. (2014). A noise and emissions assessment of the N3-X transport, 52nd Aerospace Sciences Meeting, National Harbor, MD. <https://doi.org/10.2514/6.2014-0594>.

List of Figures

- Fig. 18** Boeing deliveries in 2019 [1]
- Fig. 19** Emission reduction goals [2-3]
- Fig. 20** MEE and traditional system comparison [9]
- Fig. 21** Boeing SUGAR aircraft [11]
- Fig. 22** NASA N3X aircraft [10]
- Fig. 23** No-bleed engine architecture of the MEA [5]
- Fig. 24** Architecture of the AMB system [13]
- Fig. 8** Comparison between conventional bearings and AMBs [14]
- Fig. 25** An electric SG [19]
- Fig. 26** EHA and EMA [20]
- Fig. 27** Configuration of the fuel pump system [9]
- Fig. 28** SFC improvement for the MEE [9]
- Fig. 29** Series hybrid electric propulsion system [10]
- Fig. 30** Parallel hybrid electric propulsion system [10]
- Fig. 31** Turboelectric propulsion system [10]
- Fig. 16** All-electric propulsion system [10]
- Fig. 32** Typical flight mission profile for civil aircraft [23]

Review of more electric engines for civil aircraft

Liu, Yixiong

2022-05-12

Liu Y, Mo D, Nalianda D, et al., (2022) Review of more electric engines for civil aircraft.
International Journal of Aeronautical and Space Sciences, Volume 23, Issue 4, September
2022, pp. 784-793

<https://doi.org/10.1007/s42405-022-00469-0>

Downloaded from CERES Research Repository, Cranfield University