

# Failures Mapping for Aircraft Electrical Actuation System Health Management

Chengwei Wang<sup>1</sup>, Ip-Shing Fan<sup>2</sup>, and Stephen King<sup>3</sup>

<sup>1,2,3</sup>*Integrated Vehicle Health Management Centre (IVHM), School of Aerospace, Transport and Manufacturing (SATM), Cranfield University, Bedford, MK43 0AL, UK*

[Chengwei.wang@cranfield.ac.uk](mailto:Chengwei.wang@cranfield.ac.uk)

[I.S.Fan@cranfield.ac.uk](mailto:I.S.Fan@cranfield.ac.uk)

[S.P.King@cranfield.ac.uk](mailto:S.P.King@cranfield.ac.uk)

## ABSTRACT

This paper presents the different types of failure that may occur in flight control electrical actuation systems. Within an aircraft, actuation systems are essential to deliver physical actions. Large actuators operate the landing gears and small actuators adjust passenger seats. As developing, aircraft systems have become more electrical to reduce the weight and complexity of hydraulic circuits, which could improve fuel efficiency and lower  $NO_x$  emissions. Electrical Actuation (EA) are one of those newly electrified systems. It can be categorized into two types, Electro-Hydraulic Actuation (EHA) and Electro-Mechanical Actuation (EMA) systems. Emerging electric and hydrogen fuel aircraft will rely on all-electric actuation. While electrical actuation seems simpler than hydraulic at the systems level, the subsystems and components are more varied and complex. The aim of the overall project is to develop a highly representative Digital Twin (DT) for predictive maintenance of electrical flight control systems. A comprehensive understanding of actuation system failure characteristics is fundamental for effective design and maintenance. This research focuses on the flight control systems including the ailerons, rudders, flaps, spoilers, and related systems. The study uses the Cranfield University Boeing 737 as the basis to elaborate the different types of actuators in the flight control system. The Aircraft Maintenance Manual (AMM) provides a baseline for current maintenance practices, effort, and costs. Equivalent EHA and EMA to replace the 737 systems are evaluated. In this paper, the components and their failure characteristics are elaborated in a matrix. The approach to model these characteristics in DT for aircraft flight control system health management is discussed. This paper contributes to the design, operation and support of aircraft systems.

Chengwei Wang *et al.* This is an open-access article distributed under the terms of the Creative Commons Attribution 3.0 United States License, which permits unrestricted use, distribution, and reproduction in any medium, provided the original author and source are credited.

## 1. INTRODUCTION

The use of Electrical Actuators in aircraft is increasingly adopted in recent years along with the development and use of the “Power-by-Wire” (PbW) technology. On modern aircraft, the number of actuators is on the increase. Small actuators are widely used in aircraft subsystems, such as adjusting passenger seats and controlling the cargo door. Large actuators are used in flight control and landing gear systems.

Electro-Hydraulic Actuator and Electro-Mechanical Actuator technologies have been considered mature and found in service on multiple recent large passenger aircraft types. Compared to fully hydraulic primary and secondary flight control system used in the older Boeing 737s, EMAs and EHAs replace some of the hydraulic actuators in the newer Boeing 787 as shown in Figure 1. EMAs are used for driving mid-spoiler surfaces, and trimmable horizontal stabilizers. In the Airbus 380 (no longer in production) and the new Airbus 350 XWB, EMAs are used for driving secondary flight control (flaps and slats) whereas EHAs are used for driving both primary (aileron, elevator, and rudder) and secondary flight control (spoiler and trimmer) shown in Figure 2 and summarized in Table 1.

As more EA systems are used in aircrafts, the loss of local redundancy prompted urgent concern for updates in the generic maintenance rules to manage these new systems:

- Electrical components will need to be inspected as work tasks in maintenance activities.
- An increase in testing, e.g., high current test is necessary to validate the flexibility of junction installations.
- Procedures will need to change to ensure operators safety during removal & installation.

Table 1. EA systems in flight control on Boeing 787 and Airbus 350 XWB

Aircraft Type	Primary Flight Control			Secondary Flight Control			
	Aileron	Elevator	Rudder	Flaps	Slats	Spoiler	Trimmer
Boeing 787	EHA	EHA		EHA		EHA, EMA	EMA
Airbus 350 XWB	Hydraulic, EHSA	EHSA		EMA		Hydraulic, EBHA	EHSA

- Maintenance planning will be impacted when employing preventive maintenance, or scheduled maintenance.

Intelligent predictive maintenance scheduling needs to be developed for better and more economical maintenance without comprising safety redundancy.

This study reviews the development and working principles of EA systems, discusses on failure characteristics at component/subsystem level, and consolidate the base for DT model development. The paper is structured as follows. Section 2 reviews the trend of aircraft electrification and its benefits as a basis. Section 3 discusses the advantages and limitations of EA systems, including EMA and EHA, by comparing with the traditional centralized hydraulic actuation system, and to establish the economic basis of employing EA systems in modern new passenger and cargo aircrafts. Section 4, 5 and 6 describe the structure and configurations of different types of EA systems. The study uses the Cranfield University Boeing 737 as the baseline to elaborate the different types of actuators in the flight control system. In Section 7 and 8, the authors discuss the failure characteristics at component and system levels. Two matrices are used to summarize the interconnections between system, component, failure characteristics and features. Section 9 explains the approach to model these characteristics in DT for aircraft flight control system health management. Section 10 concludes the paper.

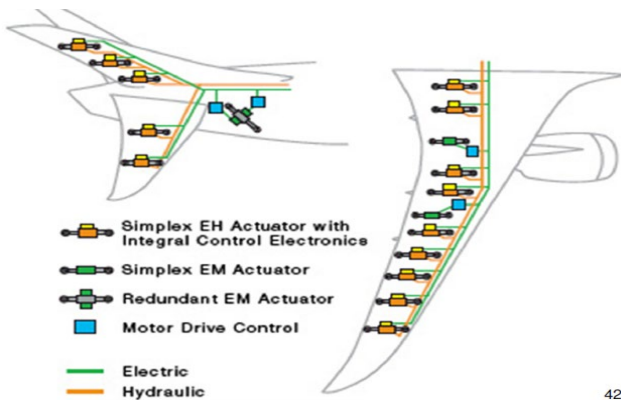

Figure 1. Boeing 787 primary flight control system (MOOG. Servo Hydraulic Technology in Flight Control)

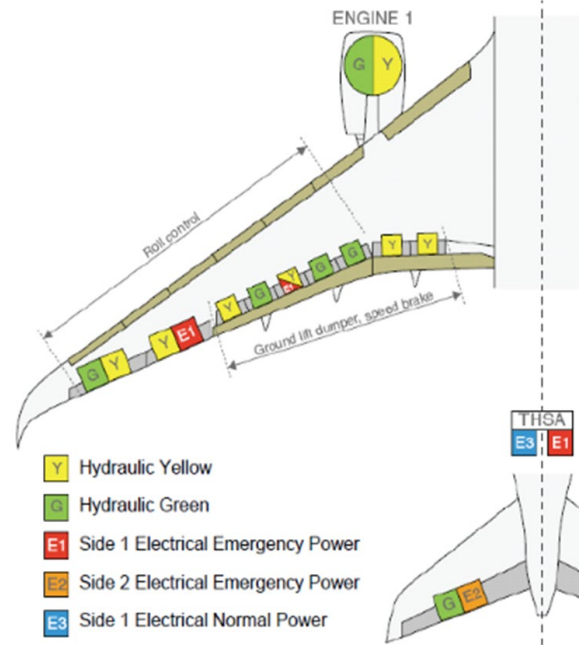

Figure 2. Airbus 350 XWB actuator and power source distribution on left wing, engine, and elevator (AIRBUS. A350 XWB: Flight Control)

## 2. BACKGROUND

The concern on higher jet fuel prices and operational cost, and the need of aviation sustainability and greenhouse emission reduction (Zaporozhets et al., 2020; Emmanouil, 2020; Janson et al., 2017) have been driving aircraft development. Sustainable Aviation Fuels (SAFs) was developed and used partially in the aviation industry with an advantage of 80% emission reduction during its full lifecycle. With the development of high output density power supply (Chakraborty et al., 2013; Terao et al., 2019), another development is the More Electric Aircraft (MEA) concept. It uses mainly electrical and electric-hybrid systems instead of combinations of secondary power sources, e.g., hydraulic, pneumatic, and mechanical, to realize certain operations.

Aircraft Electrification (AE) has various benefits. It allows for interchangeability and re-configurability as the conventional aircraft systems have reached a so-called “technology saturation” (Chakraborty et al., 2013). There is concern about increasing complexity of traditional systems and inability to design and optimize them (Telford et al.,

Table 2. Comparison between centralized hydraulic actuation and electrical actuation systems

	Advantage	Weakness/Limitation
Centralized Hydraulic Actuation	Stable, mature Time-tested and proven solution High-amount historical experience	Technology saturation Essentially redundance Added weight, complex subsystem
Electrical Actuation	Weight reduction Operation vulnerability Improved efficiency Largely eliminate losses by PbW system Transferable historical experience Simpler, lighter	Overheating/thermal dynamics issue Increased electrical power requirement Power quality concern Electromagnetic interference Mechanical jamming

2012). Aircraft electrification also brings benefits in aircraft weight reduction and power efficiency.

Lower carbon emission is another significant advantage of electrification. Aviation emissions have accelerated in recent years. The development and extension of commercial aviation continue to raise the industry’s contribution to global emissions (Overton, 2019), which reached to 915 million tons of CO<sub>2</sub> in 2019, an increase of 29% since 2013 (Graver et al., 2020). According to the EU’s Flightpath 2050 Program, it sets a goal of decreasing 75% CO<sub>2</sub> emissions per passenger kilometer and a 90% reduction in NO<sub>x</sub> emissions. With the use of fuel cell, it is expected to reduce fuel consumption by 1 to 5% and increase its efficiency by 1 to 3%.

AE can be a driver for increasing the sustainability of connectivity within cities. It is also believed to generate lower perceived noise emission, quieter during operation in another word, which benefits urban area and could meet the target of 65% reduction in Flightpath 2050 program.

There are several electric aircrafts that took to the sky. The Finnish Pipistrel Alpha Electro, a two-seat electric plane, took off in August 2018. This is believed to be a milestone for the Finnish aviation to enter a more nature-friendly future. In September 2020, Cranfield University supported ZeroAvia to successfully deliver the world’s first hydrogen fuel cell powered aircraft, which is a big move towards zero-emission aviation.

### 3. ADVANTAGES AND LIMITATIONS OF EA SYSTEMS

This section detailed discuss advantages and limitations of electrical actuation system compared to traditional centralized hydraulic actuation system. The comparison is summarized in Table 2.

Centralized hydraulic has the advantage of being a time-tested and proven solution whose operational characteristics are well-understood through decades of aeronautical experience. As a result, there is a wealth of historical experience on the centralized hydraulic actuation system.

Nevertheless, it has reached “technology saturation”, the point of diminishing return beyond which further improvements in operational efficiency are increasingly difficult to achieve. The flight control redundancy mandated by civil regulations essentially requires the incorporation of independent hydraulic lines/systems, which add both weight and complexity but can still be at risk from common-cause failures.

#### 3.1. Advantages

Electrical actuation system offers design benefits in terms of reduced weight and operational vulnerability, improved efficiency, etc.

**Improved efficiency** can be evaluated in the comparison: traditional centralized systems need to remain energized during the whole duration of the flight. In contrast, the “Power-by-Wire” system only provide the exact function required without concerns of excess or reduced power being supplied, largely eliminating the continuous losses that occur within a hydraulic circuit. This was first used in commercial aviation on the Airbus A380; and developed from the “Fly-By-Wire” firstly used in commercial aviation on Boeing 777. Similar electric approach is shown to bring 3% in lower lifecycle costs and a 6% decrease in gross take-off weight. This evolution speeded up the use of more advanced controllers, which was limited in the earlier stages of their implementation in the hydro-mechanical domain (Maré and Fu, 2017).

Significant **weight reduction** is achieved by using for flight and is summarized in Table 3. Relevant implementations can be found on A380. Using electrical signalling allows for 10% reduction of the trim horizontal stabilizer area. On A350, electrical signalling increases the aerodynamic efficiency through differential flap setting, and adaptive dropped hinged flaps (Maré and Fu, 2017).

The reduction in aircraft empty weight directly translates into reduced cost of ownership and operation.

Table 3. Weight reduction and implementation of Airbus aircraft products (Maré and Fu, 2017)

	Model				
	A300-B4	A310	A320	A340	
				A340-200	A340-500/600
Weight reduction	0	-300kg	-200kg	N/A	-50kg*
Implementation	0	-45% of rudder actuator weight**			

\*50kg mass reduction is compared to A340-200

\*\*A 45% mass reduction was achieved in A340 series compared to A300.

**3.2. Limitations**

Regarding the weakness of EA, the thermal dynamics of the actuator units is a crucial consideration since they act as localized sources of heat. The increased electrical quality requirement and the nature of the power draw requires a more elaborate consideration of power quality management and electromagnetic interference. From the design point, there is a disparity in the amount of historical experience available for hydraulic actuators versus electrical ones.

Comparing EHA to EMA, though it is heavier and more complicated, it is more suitable for side-by-side implementation with centralized hydraulics, as demonstrated EBHA units. Some historical experience with components is also transferable to the design of EHAs. The EHA system in the linear modeling method has other disadvantages, such as ignoring feedback loops with certain nonlinearity, and simplifying the friction, especially the static friction. The EMA is simpler and lighter, but it has the risk of mechanical jamming and overheating problems.

**4. ELECTRICAL ACTUATION SYSTEM**

There are four types of Electrical Actuation systems to replace traditional hydraulic ones.

**4.1. Electro-Mechanical Actuation system**

The Electro-Mechanical Actuation system is an explicit class of motion control technology systems in which it converts electricity to mechanical force to perform some type of work, e.g., control the speed and/or the position of the end-use, by means of an electric motor and a mechanical transmission, such as a reduction gearbox or a worm screw driver (SAE, 2020). The system generally consists of an Electronic Control Unit (ECU), an Electronic Power Unit (EPU), an electric motor, a mechanical drive and a position sensor.

**4.2. Electro-Hydraulic Actuation servo system**

The Electro-Hydraulic Actuation servo (EHA) system has electric and hydraulic circuits collaborating to drive a hydraulic actuator. According to MOOG, a typical EHA consists of six major elements (shown as Figure 3): (1)

control electronics (for example, control computer in the cockpit, or guidance system) to create command input signals; (2) servo-amplifier to provide a low power actuating signal, differentiating input signal from feedback signal generated by feedback transducer; (3) servo-valve which responds to actuating signal and controls the flow within the hydraulic circuits to the (4) actuator’s piston or cylinder; (5) power supply, normally an electric motor and pump, delivering high-pressure flow of hydraulic fluid within circuits; (6) a feedback transducer measures the position of the actuator (fully extended or retrieve or in progress) and converts this measurement into a proportional signal. The signal will be fed back to the servo-amplifier.

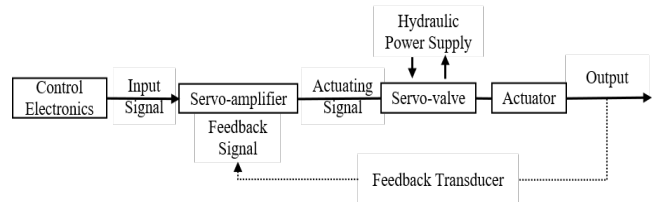

Figure 3. Schematic of a typical EHA (MOOG)

**4.3. Electro-Hydro-Static actuation system**

The Electro-Hydro-Static Actuation system (EHSA) employs an electric motor to drive a bidirectional hydraulic pump of typically fixed displacement by adjusting its steering and flow output. This completely self-contained system combines electric and electrohydraulic actuation elements. It receives power from an electric source and input a command signal (controls from cockpit via PbW) into motion. A typical EHSA includes a servomotor, hydraulic pump, accumulator, and servo-actuator (MOOG), shown as Figure 4.

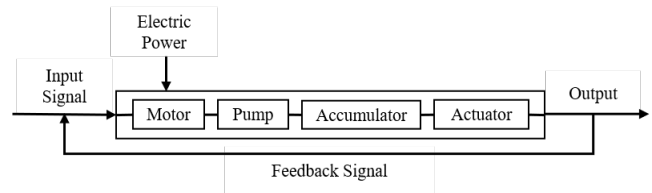

Figure 4. Schematic of a typical EHSA (MOOG)

Differentiating from EHA, it is the servo motor, or a stepping motor, to be controlled after the input signal (target command signal) and feedback signal are amplified.

#### 4.4. Electrical-Backup Hydraulic Actuation system

The Electrical-Backup Hydraulic Actuation system (EBHA) is totally segregated from the normal flight control system and is a combination of a conventional servocontrol and an EHA. In normal mode, it operates as conventional actuator. If there is a hydraulic failure, it operates as EHA.

### 5. CONFIGURATIONS OF EA SYSTEMS

This section discusses on several working configurations of EMAs and EHSAs.

#### 5.1. EMA

In general, an EMA (shown as Figure 5, also mentioned in Section 4.1) is comprised of an Electronic Control Unit (ECU), an Electronic Power Unit (EPU), an Electric Motor (EM), a Mechanical Drive (MD) and a position sensor.

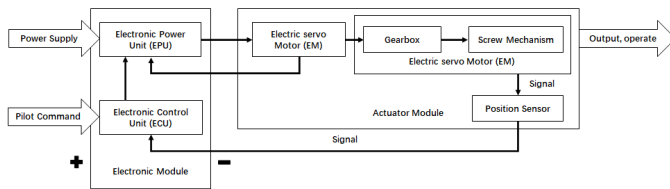

Figure 5. Schematic of a gear-driven EMA (Qiao et al., 2017)

#### 5.2. EHSA

According to the controlling mode of motor and pump, EHSA can be categorized into three types: Variable Pump and Fixed Motor (EHSA-VPFM), Fixed Pump and Variable Motor (EHSA-FPVM), Variable Pump and Variable Motor (EHSA-VPVM).

##### 5.2.1. EHSA-VPFM

The EHSA-VPFM (shown as Figure 6) employs a fixed-speed motor and a servo motor to control the swash plate angle of the axial piston pump and pump displacement. (Alle, Hiremath, Makaram, Subramanian, and Talukdar, 2016).

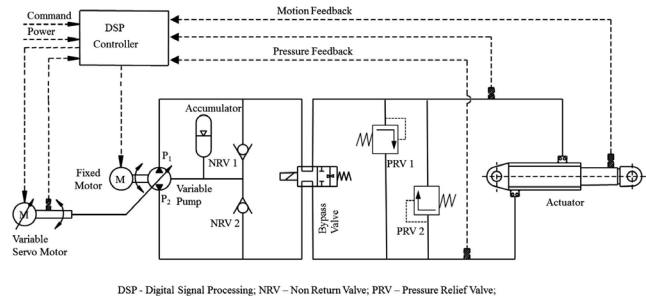

Figure 6. Schematic of an EHSA-VPFM (Alle et al., 2016)

##### 5.2.2. EHSA-FPVM

The EHSA-FPVM (shown as Figure 7) has slower dynamic response than EHSA-VPFM, but its efficiency is relatively higher (Fu, Yang, Qi, Zhang, 2011), and it benefits from its simple structure. In this system, a bi-directional pump rotates at variable speeds and directions driven by an electric motor. As a result, the oil flow and supply pressure are variable to drive the symmetrical actuator.

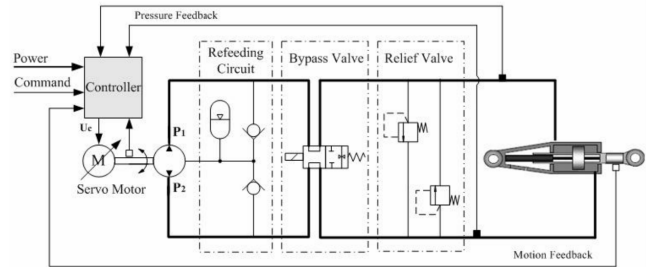

Figure 7. Schematic of an EHSA-FPVM

Kang et al. (2008) proposed a block diagram modeling method of the EHSA-FPVM to address concerns mentioned in Section 3.2. A nonlinear accuracy model is established by block diagrams, which contains more information than conventional linear model. The comparison analysis indicates the effect of EHSA refeeding circuit on reducing the pressure ripple. A gain-variable PID controller is introduced and efficiently compensates the friction. Huang et al. (2020) researched on a novel configuration, Active Load-Sensitive Electro-Hydrostatic Actuator (ALS-EHSA), by adding an active load sensing circuit, which consists of a pressure follow servo valve and a shuttle valve, on the EHSA-FPVM system. The proposed ALS-EHSA can reduce motor heating. Thanks to higher impedance, it reaches smaller displacement tracking error, near zero speed.

##### 5.2.3. EHSA-VPVM

The structure of an EHSA-VPVM is shown as Figure 8. It consists of bi-directional variable pump, controller sensors, hydraulic system, and two servo motors that adjust the displacement of pump and the rotational speed of the pump respectively.

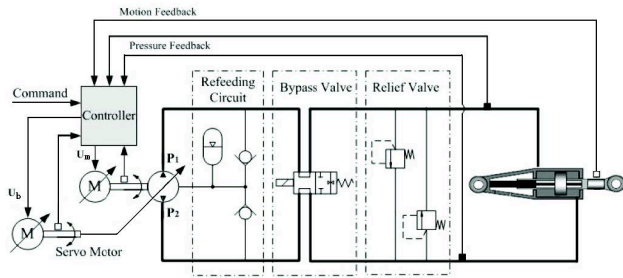

Figure 8. Schematic of an EHSA-VPVM

## 6. COMPONENTS OF EA SYSTEMS

In a complex EA, multiple components collaboratively operate to realize certain required commands from the pilot, e.g., the extension and retraction of flaps, controlling primary flight control surface. In another word, proper operation of these functions depends on stable performance of the components. Random faults happening in one of components could cause failure to the whole system.

Therefore, this section introduces and discusses the main components involved in the different types of EAs. Moreover, this section builds a foundation for evaluating the failure characteristics of systems in the next section.

### 6.1. Electrical motor

Considering the overall volume and mass, as well as long in-flight operation of an aircraft, a compact motor with high reliability and high-power density is required in flight control. In an electric aircraft, the speed of the motor would be in the range of 16000-24000 rpm or sometimes even higher in order to increase the power density. The choice of motors normally depends on the power supply on board. Common motor options are permanent magnet synchronous motor (PMSM), brushless DC (BLDC) motor, and switched reluctance (SR) motor. For example, the PMSM motor can be a suitable choice for its advantages in high performance, higher power density than induction motors in same ratings range, and fast acceleration and deceleration. While BLDCs are more cost-effective.

### 6.2. Gearbox

If the output of an EMA is rotary, the last component of the kinematic chain will be a gearbox, which is interposed between the motor and the screw providing speed reduction. The main purpose of the gearbox is to decelerate the low-torque servo motor and drive a screw mechanism to reach low speed and high torque. Harmonic gear reducers or cycloidal reducers is commonly used due to its compact structure, ease to achieve zero backlash, high reduction ratio and efficiency.

### 6.3. Screw Mechanism

If the output of an EMA is linear the last component of the kinematic chain will be a power screw, most of the time featuring the rolling element. The motor shaft is directly connected to the screw. This mechanism is employed to transform the rotary motion to linear motion with a required force. Overall weight of the actuator tends to reduce when the transmission ratio increases (Liscouët et al., 2008). While higher transmission ratio can cause a decrease in efficiency and imply a higher rotating input speed. Therefore, the balance between the reducer transmission ratio and the lead of the screw mechanism needs to be considered.

### 6.4. ECU

As mentioned in Section 4.1 and 4.3, each EA system has a suitable ECU controller, working at 28 Vdc power from external power supply. The ECU receives input command signal from cockpit and transfer to the next processes, including servo motors and EPU. For example, specific voltage input and torque output will be requested by the ECU and been transferred to the motor. Additional temperature sensors are usually installed on the controller housing close to the connectors for flight conditions with high external load. This aims at recording the external temperature changes and trigger alarm at high temperature (Qiao et al. 2017).

### 6.5. Hydraulic pump

Hydraulic pump in the EHSA is used to convert the torque input received form the motor into hydrostatic pressure and flow in the hydraulic circuits. Referring to Section 5.2, different types of pumps are used in different configurations of EHSA. Gear pumps is exclusive to the fixed displacement type, axial piston pumps and vane pumps can be either of the fixed displacement type or of the variable displacement type.

### 6.6. Hydraulic actuator

Hydraulic actuator, the operating element of an EHSA, can covert hydraulic pressure and flow into force and velocity of the actuator (Alle et al., 2016). For example, on Airbus 350 XWB, hydraulic actuators of EHSA are used to transfer linear motion and power to extend or retrieve spoilers, flaps, and slats in flight control.

## 7. FAILURE CHARACTERISTICS OF COMPONENTS

This section focuses on different failures that may occur during operations and consequences impact the subsystems.

### 7.1. Overheating

Operating temperature is always a concern on mechanism operation. Considering the transmission mechanism responds to commands and only operates for a short period, during which the heat generated from mechanical interaction itself,

e.g., gear meshing, barely attributes overheating issue and then it can be eliminated. Overheating is mainly generated within the electrical servo motor.

There are several reasons for overheating:

**Voltage unbalance** can produce serious overheating in motors due to the high negative sequence current which flows with a relatively small out-of-balance component. Normally, the motor operates with rated voltage applied and provide rated power. Transient response to pilot's commands and emergency when the voltage applied exceeds its rating. It causes sharp increase in the core magnetic flux density and iron loss and causes the motor to overheat.

**Overload** is caused by an increase in the load driven by the motor or mechanical jamming in the driven mechanism. Also, mechanical failure happens when rotor and stator are rubbed together, and the rotor is stuck in position.

The **lack of lubricating** oil or grease causes sleeve bearing damage. Electric motors use either rolling or sleeve bearings of lubricated inner and outer ring metal surfaces to reduce friction. These balls or rollers hold the load and support the motor shaft so that the rotor can rotate smoothly and stably. It is normal to choose bearings which will give a life of 50,000-100,000h running, or even 200,000h on the larger motors. Hence, it is essential to ensure minimum wear in normal operation and achieve sufficient use life. Worn shaft collars could failed to isolate the inner bearing from the outside air. Therefore, air will be absorbed in and deteriorate the lubricant grease, corrode balls or rollers. This issue leads to power fluctuation, and uneven and unstable rotor operation as a result, with excessive heat generated.

## 7.2. Mechanical jamming

**Mechanical jamming** happens in both motors and transmission mechanisms. As stated in Section 7.1, the rotor rubbed with the stator causes failure of overheating. In the gearbox, worm gear and bearings lead to unstable axial rotation and vibration of transmission shaft. Deteriorated or contamination-collected lubricant grease accelerates tooth wear. Normal failures happen under the above circumstances include gear teeth fracture, teeth surface fatigue pitting, surface glued and plastic deformation.

## 7.3. Hydraulic leakage

Hydraulic cylinder is the actuator in the hydraulic system, and its failure directly affects the normal operation of the system. The **leakage** of hydraulic cylinder is a major failure mode usually caused by failure or damage of the seal. Air will be absorbed due to worn piston seal or cylinder barrel, which can accelerate wear and tear, excessive internal leakage, and cause **pressure loss** and piston retrieve failure. It should be detected as early as possible to avoid further breakdowns of the system.

## 7.4. Electric cable wear

The extreme environment these devices operating in, e.g., temperature variation and variable pressure levels, can accelerate **cable wear** in an electric circuit. This may lead to short circuit, higher resistance, overheating or fracture, and loss control in the end.

The control cables in the wing and nacelle area are near high temperature sources. Deterioration of lubricants will occur at a faster rate than on other control cables.

## 7.5. Unstable power supply

**Power generation breakdown** is another hidden danger. In the circumstance that one or more of the aircraft's power source fails, and the remaining sources cannot provide sufficient power to maintain the whole system in normal operation until emergency landing would lead to a catastrophe. The constraint frequently imposed by the power supply is the maximum current or kilovolt-amperes which may be drawn during starting, a condition which may be met either by a lower starting current design of motor or by use of some form of soft-start device to reduce the current drawn during starting. When considering the supply constraints, the source impedance must also be considered to ensure that there is sufficient voltage at the machine terminals to overcome the load torque, leaving sufficient torque in hand to accelerate the motor against load.

## 8. FAILURE FEATURES

Features such as input voltage, output torque, temperature can simultaneously reflect a system's operational status. Failure identification involves selecting features from relevant aspects and filtering unclear features or interference. Further data analysis against parameter uncertainties improves failure identification.

### 8.1. Features at component level

Correlating components in Section 6 and failure characteristics in Section 7, features can be linked and correlated, as shown in Table 4. For example, bearings that are corroded or lack of lubrication cannot support rotors rotating in a stable condition, irregular vibration could be detected. The frequency of vibration and the vibration of the rotor or the motor can be set as feature references. The two values of frequency and amplitude of normal operation, natural operational condition, can be used as thresholds. When abnormal conditions occur, the feature signals will activate the trigger, which can be a clue of failure in bearings and the specific components involved.

### 8.2. Failure effects at subsystem level

In Table 5, the fault of systems is traced to specific ranges of failure characteristics at the component level. When a fault alarm shows up in EMA, indicating an abnormal operation, it

Table 4. A summary of fault, related features and measurement reference of components of EA systems

Subsystems/Components	Fault	Feature	Unit
Electric Motor	Electrical overload	Excessive voltage input	+ΔV
		Excessive torque output	+ΔN·m
Mechanism Transmission (Gearbox, screw mechanism)	Overheating	Temperature	+Δ°C
	Irregular vibration	Frequency	(times)
		Amplitude	+Δmm
ECU	Fluid leakage	Pressure drops	+ΔPa
		Shortened displacement	-Δx
Hydraulic Pump	Jamming	Delayed response	+Δt
	Electric cable wear	Irregular torque output	+ΔNM
Hydraulic Actuator		Unstable power supply	Excessive voltage
	Short circuit (Excessive amplitude)		+ΔA
	Excessive resistance		+ΔΩ
		Voltage input drop	-ΔV
		Amplitude input drop	-ΔA
		Insufficient torque output	-ΔN·m

may be caused by electric overload, overheating, irregular vibration (normally caused by worn bearings), gear jamming or unstable power supply, or even worn electric cable.

If a temperature rise is reported in the flight control system, troubleshooting through tracing back to the component level can help to distinguish whether the cause is the motor or the ECU, or either mechanism or hydraulic mechanisms.

This matrix forms the basis for further research on DT modelling, failure simulation, and efficient and sufficient fault diagnosis and locating.

**9. HEALTH MONITORING METHODS**

Since the development of EA, several configurations of it have been used in recent commercial aircrafts. This section discusses current maintenance methods captured from the

Aircraft Maintenance Manual as well as state-of-the art techniques to be applied to future aircraft maintenance activities.

**9.1. Current method during maintenance**

According to the Aircraft Maintenance Manual of the Cranfield University Boeing 737, the MSG-3 based preventive/scheduled maintenance program is practiced. Using the inspection of the spoiler part in flight control system as an example (AMM TASK 27-61-00). Current maintenance schedule is divided into two parts, covering in different maintenance checks level. One is to thoroughly inspect the system, including the spoiler control cables, the spoiler mixer and the spoiler actuator (TASK number 27-61-00-211-801). Another one is to carry out general visual

Table 5. A summary of interconnection from system level to component level and their fault characteristics

EA System	Component	Fault
EMA	Gearbox	Electric motor
	Screw mechanism	
EHSA	-VPVM	ECU
	-FPVM	Hydraulic Pump
	-VPFM	Hydraulic actuator
		Electrical overload
		Overheating
		Irregular vibration
		Fluid leakage
		Jamming
		Electric cable wear
		Unstable power supply

inspection on the flight spoiler actuator from the ground (TASK 27-61-00-210-801).

In the thorough inspection TASK 27-61-00-211-801, certain aircraft areas are checked, including left and right main wheel well, both trailing edges outboard and inboard of flap and spoiler, and fixed trailing edges between them, on both left and right wings. The maintenance technician will access the control panels to operate certain surfaces prior, during and after the inspection. The AMM also stated that only corrosion-preventive grease and lint-free cloth are permitted.

Following with a ground visual inspection TASK 27-61-00-210-801, maintenance technicians will do a general visual inspection of the ground and flight spoiler actuators looking for security of installation, leaks, corrosion, and obvious damages. After completing above subtasks, together with other preventive maintenance activity, the maintenance technician can sign-off the aircraft to be ready to go.

Current preventive maintenance reserves sufficient safety redundancy as a system/subsystem will be inspected within a certain flight hour interval according to the check level. A component will be replaced when either found faulty or reaches its pre-set use life. However, in practice, replaced components usually have remaining life, depending on the component, operational environment and human (pilot, maintenance technician) operation behaviours. Therefore, it is more economical and sustainable to seek a better maintenance program to maximize the usage of component/subsystem's life without sacrificing the safety and overall operational flight time as well as turnaround time.

## 9.2. Potential method

Predictive maintenance can be a potential solution to efficiently monitor EA health. Such maintenance activity is scheduled based on operations of facilities and systems themselves. It employs the Internet of Things (IoT), Big Data and further DT technology. DT is a software design pattern (Gartner, 2019) that presents a physical object to gain a clearer picture of real-world performance and duplicate operations of an asset in real-time referring to real-time collected data from the asset and deduce reliable operation decisions (Qi and Park, 2020), e.g., responding to changes in time and adding value.

### 9.2.1. Industrial employment

Rolls-Royce released its world-largest aero-engine in early 2021. Referring to the company's IntelligentEngine vision, a DT model is built for each fan blade to store real-life test data, allowing engineers to predict in-service performance.

Air France Industries, KLM Engineering & Maintenance Adaptiveness (AFI KLM E&M) developed the Prognos system, a Big Data-based predictive maintenance solution, which is adapted to multiple aircraft systems and relevant

operations, including Engine, EPCOR for APU, fleet MRO scheduling and inventory optimization.

### 9.2.2. Research development

Ezhilarasu et al. (2019) investigated the feasibility of DT being combined with Integrated Vehicle Health Management (IVHM) as a decision tool. One of the key roles it can play is to form a platform for integrating information to monitor operations and then duplicate the health status of the complex systems like an aircraft.

Xu et al. (2020) proposed a DT-driven analysis framework (DTAF) for optimizing gas exchange system of 2-stroke heavy fuel aircraft engine. In this research, different DT modules interact with their targeted physical entities of engine and work collaboratively within the DT virtual group. With continuous interaction and correction of DT modules, and real-time data exchange between physical test platforms, DTAF is proven to be efficient and reliable.

Alvarez et al. (2019) developed an DT-corporate solution to aircraft loss of control caused by incorrect measurement readings of the Pitot tube and Air Data Computer (ADC) computing false. This solution aims at using real-time data from other airborne sensors and the virtual sensor DT represented to correctly estimate true airspeed in real-time. The study shows the additional DT virtual sensor can increase the accuracy of the estimation even during downward of the velocity and the altitude.

## 9.3. Comparison between stated methods

As a mature method, preventive maintenance is well established and regulated alongside the development of aircraft. It benefits from abundant historical documentation, long service experience, and well-trained technicians. Though, regular repetitive activities may lead to human errors. In the crash of Alaska Airlines Flight 261 (NTSB AAR, 2000), the jammed longitudinal trim control system was caused by missed maintenance activities, including no effective lubrication, excessive and accelerated jackscrew wear. The human error is a symptom of ineffective task-by-task engineering analysis and justification.

Predictive maintenance could avoid unnecessary downtime caused by redundant interventions (Zhen et al., 2018). It also prevents losses caused by cascading failures which are affected by untimely maintenance actions. In another word, predictive maintenance helps to increase system reliability while brings down its cost. However, adding more smart techniques and sensors to a certain system adds cost. Predictive maintenance also introduces unplanned dynamics to maintenance demand scheduling and a challenge to the economics of practical maintenance planning.

## 10. CONCLUSION

This paper discusses in detail EA systems used in aircraft flight control system, including the origin, working principles, subsystem configurations and environmental constraints:

- 1) Background investigation shows AE has become established practice, and EA systems have generally been mature and achieved extensive application on commercial aircrafts.
- 2) A comparison of traditional centralized hydraulic actuation is conducted through access to the AMM of the Cranfield University Boeing 737. The comparison between centralized hydraulic actuation system and EA system is presented to demonstrate the advantages of EA systems, also pointing out key concerns regarding designing and maintenance.
- 3) Different types of EA systems are described, which includes the EMA, and three configurations of EHSAs.
- 4) A detailed analysis is carried out on EA systems by breaking down to the component level, including electrical motor, transmission mechanism, hydraulic pump and cylinder. Failure characteristics of components are evaluated.
- 5) A matrix helping to trace failure in system level via subsystem/component level is presented. It relates the failure characteristics and helps define outstanding features that can be used to indicate correlated faults in further studies.
- 6) Maintenance methods including those carried out in current maintenance activities and novel technologies which are shown in the trend in research are briefly reviewed.

The authors are building on this work to develop a data-driven DT model to represent real EA systems. The validated DT model will be used to support predictive maintenance for EA system health management.

## REFERENCE

MOOG. *Primary Flight Control Actuation System for 787*. Available at: <https://www.moog.com/products/actuation-systems/aircraft/primary-flight-control-actuation-system-for-787.html> (accessed: 10 Dec 2020)

AIRBUS. *A350 XWB: Flight Control, Flight Deck and Systems Briefing for Pilots*, p. 8-9. Available at: <https://www.parlonsaviation.com/wp-content/uploads/2017/12/a350-flight-controls.pdf> (accessed: 10 Dec 2020)

Y. Terao, A. Seta, H. Ohsaki, H. Oyori, N. Morioka. (2019). *Lightweight Design of Fully Superconducting Motors for*

*Electrical Aircraft Propulsion Systems*, IEEE Transaction on Applied Superconductivity, Vol. 29, No. 5, Aug 2019. DOI: 10.1109/TASC.2019.2902323.

Chakraborty, D. Jackson, D. Trawick. (2013). *Development of a Sizing and Analysis Tool for Electrohydrostatic and Electromechanical Actuators for the More Electric Aircraft*, 2013 Aviation Technology, Integration, and Operations Conference, AIAA AVIATION Forum, Aug 2013. DOI: 10.2514/6.2013-4282.

Zaporozhets, V. Isaenko, K. Synylo. (2020). *Trends on current and forecasted aircraft hybrid electric architectures and their impact on environment*, Energy, Vol. 211, Nov 2020. DOI: 10.1016/j.energy.2020.118814.

K. Emmanouil. (2020). *Reliability in the era of electrification in aviation: A systems approach*, Microelectronics Reliability, Vol. 114, Nov 2020. DOI: 10.1016/j.microrel.2020.113945.

R. H. Janson, C. Bowman, A. Jankovsky, R. Dyson, J. Felder. (2017). *Overview of NASA Electrified Aircraft Propulsion Research for Large Subsonic Transports*, 53rd AIAA/SAE/ASEE Joint Propulsion Conference, AIAA Propulsion and Energy Forum, Jul 2017. DOI: 10.2514/6.2017-1701.

IATA. *Developing Sustainable Aviation Fuel (SAF)*. Available at: <https://www.iata.org/en/programs/environment/sustainable-aviation-fuels/#tab-2> (accessed: 10 Dec 2020)

R. D. Telford, S. J. Galloway, G.M. Burt. (2012). *Evaluating the Reliability & Availability of More-Electric Aircraft Power Systems*, 2012 47th IUPEC, Sep. 2012. DOI: 10.1109/IUPEC.2012.6398542.

P. Traverse, I. Lacaze, J. Souyris. (2004). *Airbus Fly-by-Wire: A Total Approach to Dependability*, IFIP International Federation for Information Processing, Vol. 156. DOI: 10.1007/978-1-4020-8157-6\_18.

G.F. Bartley. (2001). *Boeing B-777: Fly-By-Wire Flight Controls*, Chap. 11, the Avionics Handbook, Boca Raton, CRC Press. Available at: [https://www.davi.ws/avionics/TheAvionicsHandbook\\_Contents.pdf](https://www.davi.ws/avionics/TheAvionicsHandbook_Contents.pdf) (accessed: 10 Dec 2020)

J. W. Ramsey. (2001). *Power-by-Wire*, Aviation Today. Available at: <https://www.aviationtoday.com/2001/05/01/power-by-wire/> (accessed: 10 Dec 2020)

J. Overton. (2019). *Fact Sheet: The Growth in Greenhouse Gas Emissions for Commercial Aviation*, Environmental and Energy Study Institute, Oct 2019. Available at: <https://www.eesi.org/papers/view/fact-sheet-the-growth-in-greenhouse-gas-emissions-from-commercial-aviation> (accessed: 10 Dec 2020)

ATAG. *Facts & Figures*. Available at: <https://www.atag.org/facts-figures.html> (accessed: 10 Dec 2020)

B. Graver, D. Rutherford, S. Zheng. (2020). *CO2 Emissions from commercial aviation: 2013, 2018, and 2019*, the

- International Council on Clean Transportation, Oct 2020.
- European Commission. *Flightpath 2050: Europe's Vision for Aviation*. Available at: <https://ec.europa.eu/transport/sites/transport/files/modes/air/doc/flightpath2050.pdf> (accessed: 10 Dec 2020)
- IATA. *Aircraft Technology Roadmap to 2050*. Available at: <https://www.iata.org/contentassets/8d19e716636a47c184e7221c77563c93/technology20roadmap20to20205020no20foreword.pdf> (accessed: 10 Dec 2020)
- Pipistrel. *First flight of an electric aircraft in Finland*. Available at: <https://www.pipistrel-aircraft.com/first-flight-of-an-electric-aircraft-in-finland/> (accessed: 10 Dec 2020)
- Cranfield University. *Cranfield supports ZeroAvia's world first hydrogen-electric passenger aircraft flight*. Available at: <https://www.cranfield.ac.uk/press/news-2020/cranfield-supports-zeroavias-world-first-hydrogen-electric-passenger-aircraft-flight> (accessed: 10 Dec 2020)
- SAE. *AIR8012: Prognostics and Health Management Guidelines for Electro-Mechanical Actuators*, SAE International. DOI: 10.4271/AIR8012.
- MOOG. Electrohydrostatic. Available at: <https://www.moog.com/products/actuators-servoactuators/actuation-technologies/electrohydrostatic.html> (accessed: 20 Feb 2022)
- MOOG. Electrohydraulic. Available at: <https://www.moog.com/products/actuators-servoactuators/actuation-technologies/electrohydraulic/> (accessed: 20 Feb 2022)
- J. Maré, J. Fu (2017). *Review on signal-by-wire and power-by-wire actuation for more electric aircraft*, Chinese Journal of Aeronautics, 2017, 30(3), pp. 857-870. DOI: 10.1016/j.cja.2017.03.013
- G. Qiao, G. Liu, Z. Shi, Y. Wang, S. Ma, and T. C. Lim (2017). *A review of electromechanical actuators for More/All Electric aircraft systems*, Journal of Mechanical Engineering Science, 2018, Vol. 232 (22), pp. 4128-4151.
- N. Alle, S. S. Hiremath, S. Makaram, K. Subramaniam and A. Talukdar (2016). *Review on electro hydrostatic actuator for flight control*, International Journal of Fluid Power, 2016, Vol. 17, NO. 2, pp. 125-145.
- Y. Fu, B. Yang, H. Qi, Y. Zhang (2011). *Optimization of the Control Strategy for EHA-VPVM System*, Proceedings of 2011 International Conference on Electronic & Mechanical Engineering and Information Technology, 2011, pp. 1856-1859. DOI: 10.1109/EMEIT.2011.6023001
- R. Kang, Z. Jiao, S. Wu, Y. Shang, J. Maré. (2008). *The Nonlinear Accuracy Model of Electro-Hydrostatic Actuator, 2008 IEEE Conference on Robotics, Automation and Mechatronics*, 2008, pp. 107-111, DOI: 10.1109/RAMECH.2008.4681367.
- L. Huang, T. Yu, Z. Jiao, Y. Li. (2020). *Active Load-Sensitive Electro-Hydrostatic Actuator for More Electric Aircraft*, Appl. Sci. 2020, 10(19), 6978. DOI: 10.3390/app10196978.
- J. Liscouët, J. Maré, S. Orioux (2008). *Automated Generation, Selection and Evaluation of Architectures for Electromechanical Actuators*, 26<sup>th</sup> International Congress of the Aeronautical Sciences, 2008, pp. 14-19.
- Gartner. *Gartner Survey Reveals Digital Twins Are Entering Mainstream Use*. Available at: <https://www.gartner.com/en/newsroom/press-releases/2019-02-20-gartner-survey-reveals-digital-twins-are-entering-mai> (accessed: 10 Dec 2020)
- B. Qi, H.S. Park. (2020). *Data-driven digital twin model for predicting grinding force*, IOP Conf. Ser.: Mater. Sci. Eng. 916 012092. DOI: 10.1088/1757-899X/916/1/012092.
- Rolls-Royce, (2019). *How Digital Twin technology can enhance Aviation*. Our stories - How Digital Twin technology can enhance Aviation –Rolls-Royce (Accessed: 9 May 2021)
- AFI KLM E&M. *Prognos*. Available at: The MRO Lab - PROGNOSE® - Predictive Maintenance (afiklmem.com) (accessed: 19 May 2021)
- C.M. Ezhilarasu, Z. Skaf, I.K. Jennions. (2019). *Understanding the role of a Digital Twin in Integrated Vehicle Health Management (IVHM)*, 2019 IEEE Int. Conf. SMC, Oct 2019. DOI: 10.1109/SMC.2019.8914244.
- Z. Xu, F. Ji, S. Ding, Y. Zhao, Y. Zhou, Q. Zhang, F. Du. (2020). *Digital twin-driven optimisation of gas exchange system of 2-stroke heavy fuel aircraft engine*, Journal of manufacturing Systems. DOI: 10.1016/j.jmsy.2020.08.002.
- O.H. Alvarez, L.B.G. Zea, C. Bil, M.L. Fravolini, M. Napolitano. (2019). *Digital Twin Concept for Aircraft System Failure Detection and correction*, AIAA Aviation Forum, June 2019. DOI: 10.2514/6.2019-2887.
- National Transportation Safety Board, Washington D.C. (2000). *Aircraft Accident Report: Loss of Control and Impact with Pacific Ocean Alaska Airlines Flight 261. McDonnell Douglas MD-83, N963AS. About 2.7 Miles North of Anacapa Island, California*. January 31, 2000, NTSB/AAR-02/01. Available at: <https://www.nts.gov/investigations/AccidentReports/Reports/AAR0201.pdf> (accessed: 12 March 2022)
- S. Zhen, Z. Wu, K. Xu, Q. Wang, P. Han, H. Yang, Y. Chen. (2018). *Predictive Maintenance White Paper*, Shanghai Industrial Technology Institute. Available at: <https://www.siti.sh.cn/> (accessed: 12 March 2022)

## BIOGRAPHIE



**Chengwei Wang** is currently a PhD research student at Cranfield University, Bedfordshire, UK. He was born in Yancheng, China in 1996. He obtained his dual bachelor's degree with First Class Honours in Mechanical Engineering Technology from The University of Greenwich, UK, and the Yancheng Institute of Technology, China in 2018. He received his master's degree

in Aerospace Manufacturing from Cranfield University in 2019. He previously participated as a research assistant in the Natural Resources Institute, University of Greenwich for a 3-month internship. His research focuses on understanding failure characteristics of electrical actuation systems on aircrafts and the development of applied Digital Twin techniques for aircraft system health management. He is also interested in bringing digital techniques into the aviation sector.



**Ip-Shing Fan** is currently on the Education and Scholarship pathway. He was born and studied in Hong Kong, graduated with First Class Honours in Industrial Engineering. He completed his graduate engineer training at Qualidux Industrial Co Ltd in Hong Kong. He was awarded the Commonwealth Scholarship and completed his PhD in Computer

Integrated Manufacturing in Cranfield. After returning to Hong Kong, he worked as CAD/CAM Manager in Qualidux Industrial Co Ltd, responsible for the introduction of CAD, CAM, and CNC in plastic injection design and engineering. In 1990, Fan started to work in The CIM Institute, endowed by IBM in Cranfield, to carry out research, education, and consultancy in new applications of computers in manufacturing. He led many European and UK funded research programs to create new tools and methods in

knowledge-based engineering design, business performance, quality management, supply chain, and complexity science. He has a passion to understand the underlying reasons and develop better approaches to help organizations work more effectively. He looks at the world with a socio-technical lens to explore the complex interactions between people systems and technology systems. The knowledge span includes system engineering, business process analysis, quality and performance management system, organization design and behaviour, technology induced change, human psychology and motivation. The application domains include aerospace, engineering, manufacturing, business services, IT, education, health, local government.



**Stephen King** is currently a part-time senior Lecturer in Advanced Analytics having recently retired from Rolls-Royce (April 2020) where he was an Engineering Associate Fellow and EHM Specialist working within the Rolls-Royce Digital organisation. During his 41-year career at Rolls-Royce he held positions within the Measurement

Engineering group, Electronics and Measurement Techniques department, Strategic Research Centre, Business Process Improvement Centre, Controls Engineering and System Design Engineering. Prior to this he worked for Electronic Flow Meters where he was responsible for the test and commissioning of flow measurement systems in the oil and gas industry. His main interests are in the use of data mining and advanced analytical techniques for asset health monitoring applications. He holds a degree in Mathematics and Computer Science and a PhD in the application of expert systems for vibration analysis. In addition to being a Chartered Engineer, he is a Fellow member of both the Institution of Engineering and Technology and the Institute of Mathematics and its Applications.

# Failures mapping for aircraft electrical actuation system health management

Wang, Chengwei

2022-06-29

Attribution 3.0 International

---

Wang CW, Fan IS, King S. (2022) Failures mapping for aircraft electrical actuation system health management. In: 7th European Conference of the PHM Society (PHME 2022), 6-8 July 2022, Turin, Italy

<https://doi.org/10.36001/phme.2022.v7i1.3354>

*Downloaded from CERES Research Repository, Cranfield University*