

Barriers to adoption of industry 4.0 and sustainability: a case study with SMEs

Shashank Kumar, Rakesh D. Raut, Emel Aktas, Balkrishna E. Narkhede & Vidyadhar V. Gedam

To cite this article: Shashank Kumar, Rakesh D. Raut, Emel Aktas, Balkrishna E. Narkhede & Vidyadhar V. Gedam (2023) Barriers to adoption of industry 4.0 and sustainability: a case study with SMEs, International Journal of Computer Integrated Manufacturing, 36:5, 657-677, DOI: [10.1080/0951192X.2022.2128217](https://doi.org/10.1080/0951192X.2022.2128217)

To link to this article: <https://doi.org/10.1080/0951192X.2022.2128217>



© 2022 The Author(s). Published by Informa UK Limited, trading as Taylor & Francis Group.



[View supplementary material](#)



Published online: 11 Oct 2022.



[Submit your article to this journal](#)



Article views: 2398



[View related articles](#)





[View Crossmark data](#)



Citing articles: 2 [View citing articles](#)

Barriers to adoption of industry 4.0 and sustainability: a case study with SMEs

Shashank Kumar ^a, Rakesh D. Raut ^a, Emel Aktas ^b, Balkrishna E. Narkhede ^a and Vidyadhar V. Gedam ^c

^aDepartment of Operations and Supply Chain Management, National Institute of Industrial Engineering (NITIE), Mumbai, Maharashtra, India;

^bDepartment of Logistics, Procurement and Supply Chain Management, School of Management, Cranfield University; ^cSustainability Management, National Institute of Industrial Engineering (NITIE), Powai, Mumbai, India

ABSTRACT

The concepts of sustainable supply chains and Industry 4.0 are progressively getting attention in different domains. Companies have started developing and implementing these practices in their business models. However, several challenges influence the adoption of sustainability and Industry 4.0 (I4.0) in small and medium-sized enterprises (SMEs). This study aimed (i) to identify the adoption barriers of sustainability and I4.0 and (ii) to establish the interrelationship among these barriers for SMEs. An extensive literature search supported by interviews with supply chain practitioners from three SMEs identified 12 critical barriers to adoption. The barriers are then ranked using 'Interpretive Structural Modeling'. The results suggest that the 'lack of resources' and the 'lack of employee's competence/expertise' are the most influencing barriers. Changing government regulations on the allocation of capital and financial incentives for SMEs to encourage training and skills development programs could promote sustainable supply chains and practices. The study also reflects short-, medium- and long-term planning strategies for supply chain practitioners for adoption of sustainability and I4.0 in SMEs.

ARTICLE HISTORY

Received 5 October 2021

Accepted 12 September 2022

KEYWORDS

Supply chain; sustainability; barriers; sustainable and industry 4.0; interpretive structural modeling; SMEs

1. Introduction

The concern about sustainability is increasing among supply chain decision-makers and academics since the beginning of the last century (Manupati et al. 2020). Government and organizational policies strive to systematically integrate sustainability into supply chain practices to improve 'ecological', 'social', and 'financial' performance (Kumar et al. 2021a). The increasing demand for sustainable goods among consumers has generated interest among supply chain stakeholders for sustainability learning and practices (Naughton, Golgeci, and Arslan 2020). Although the initiative for sustainability has been increasing the performance of an organization, SMEs' top management has been worried about implementing it due to high cost and extra resource burden. Organizations have started forming alliances with public and private firms to acquire knowledge and support sustainability in the supply chain process (Benešová et al. 2021). In addition to external support, organizations have started transforming their supply chain processes through innovative technologies enabling 'sustainability oriented capabilities' (Demirel and Kesidou

2019) since emerging technologies have the potential to affect an organization's sustainability performance (Nimawat and Gidwani 2021).

The trend of technology adoption and its application in the supply chain (SC) has been increasing since 2011, after the rise in the concept of the fourth industrial revolution or Industry 4.0 (I4.0) (Da Silva et al. 2020). I4.0 is the fourth industrial revolution (Figure 1), which is explained as integration of smart technologies like IoT, big data, cyber-physical systems, additive manufacturing, sensors, artificial intelligence, blockchain, etc. (Sanchez, Exposito, and Aguilar 2020). It is a concept in which digital sensors, smart products, and intelligent devices coordinate with each other, engage with the ecosystem to perform operations with less human involvement (Gilchrist 2016). The growing number of research studies linking SC sustainability and Industry 4.0 application, claiming that it can generate sustainable SC opportunities such as resource management or sustainable growth, as well as a sustainable business model transformation (Saqib and Zhang 2021). Despite there are financial and infrastructural barriers in incorporating the I4.0 in

CONTACT Emel Aktas  emel.aktas@cranfield.ac.uk  Department of Logistics, Procurement and Supply Chain Management, School of Management, Cranfield University, College Road, MK43 0AL, Cranfield, UK

 Supplemental data for this article can be accessed online at <https://doi.org/10.1080/0951192X.2022.2128217>.

© 2022 The Author(s). Published by Informa UK Limited, trading as Taylor & Francis Group.

This is an Open Access article distributed under the terms of the Creative Commons Attribution License (<http://creativecommons.org/licenses/by/4.0/>), which permits unrestricted use, distribution, and reproduction in any medium, provided the original work is properly cited.

Industry 1.0: from agriculture to industrial society
Using steam engines, craft production

Industry 2.0: from late 19th century to early 1980s
Using electricity, mass production

Industry 3.0: from 1980s to 2010s
Using information and analogue to digital devices, mass customisation

Industry 4.0: from 2010s to near future
Using Internet of Things, big data analytics, cyber-physical systems, smart factories

Figure 1. Evolution of industry 4.0. (Adapted from Yin, Stecke, and Li 2018)

current working environment, the studies (Ghobakhloo and Fathi 2020) have demonstrated the advantages of incorporating I4.0 in manufacturing for SC sustainability.

Large enterprises appear to be making the shift to I4.0 at a faster rate than ‘small and medium-sized businesses (SMEs)’, as it needs substantial planning, policy, and organizational support (Agostini and Nosella 2020). Today, SMEs contribute to ‘90%’ of businesses and ‘50%’ of jobs worldwide, with a share of ‘40%’ of Gross Domestic Product (GDP) in developing countries (The World Bank 2020). The implementation of green manufacturing practices that are considered as part of sustainable practices is vital to SMEs’ existence in the global market (Karuppiyah et al. 2020). Unfortunately, the process of applying I4.0 is not convenient for many SMEs due to the scarcity of formalized procedures and limited resources (Dassisti et al. 2018). As SMEs play a significant role in most economies, particularly in developing countries that account for potential job growth and sustainable economic progress, it becomes critical to implement I4.0 to compete in domestic and international markets (Masood and Sonntag 2020). However, due to varied demands and diversified consumer needs in sustainable industrial contexts, SMEs are having difficulty implementing I4.0 (Chen, Liu, and Wang 2021). In literature a limited research work promotes the SC sustainability and I4.0 in context of SMEs. However, few studies combined the implementation of SC sustainability and I4.0 within SMEs by highlighting and identifying issues and barriers. There is need

to understand the challenges and barriers that includes awareness-raising policies, initiatives, constraints, and business frameworks for effective transformation of SMEs. In literature there is limited access of research questions like (1) What kind of challenges SMEs are facing while adopting sustainability and I4.0? (2) Is there any relationship among these challenges? and if it is there, (3) how to approach it, to reduce its impact during adoption of I4.0 for sustainable practices? With the primary aim to make it possible for SMEs to achieve sustainable practices through I4.0, this paper attempted to answers the above research questions by formulating the following research objectives (RO) for this study:

- RO1.** To identify the adoption barriers of sustainability and I4.0 in SMEs.
- RO2.** To obtain the interrelationships between the identified barriers.
- RO3.** To develop guidelines to increase the adoption of sustainability and I4.0 practices by SMEs.

The rest of the paper is organized as follows. **Section 2** reviews the literature on the adoption of sustainability and I4.0 in SMEs, identifying the barriers and research gaps. **Section 3** explains the research methodology. **Section 4** presents the identified barriers to the adoption of sustainability and I4.0 in SMEs, along with the data collection process. Data analysis and the results are demonstrated in **Section 5**.

Section 6 provides a discussion of the study, and Section 7 depicts the conclusions, managerial implications, limitations, and future research directions.

2. Literature review

For the purpose of presenting the backdrop of this study, a comprehensive review of articles published in Scopus and Web of Science was conducted to gain insights into sustainability and Industry 4.0 practices in SMEs. The search was limited to articles written in English and published in peer-reviewed journals. In the article title, keywords like ('Industry 4.0' AND 'Sustainability') and ('Industry 4.0' OR 'Sustainability') were searched. The search was then filtered using terms like 'SMEs', 'Industry 4.0 adoption', and 'sustainable practices'. Abstract and title filtration techniques were used to make the final selection of publications included in the literature review of this study.

SC practitioners are continually looking to implement emerging technologies to improve their business processes and ensure sustainability (Li et al. 2020). Organizations worldwide are now witnessing significant transitions (called the fourth industrial revolution) in the SC process and operations via digitalization and integration of modern technologies into practice (Ingaldi and Ulewicz 2020). The business community adopted the concepts of Sustainability and Sustainable Development (SD), encompassing the economic, environmental, and social dimensions (Carroll and Shabana 2010). Sustainability can be regarded as an umbrella construct that encompasses concepts and ideas such as corporate responsibility, business ethics, corporate citizenship, and sustainable development (Fonseca 2015). On a theoretical level, sustainability is supported by Stakeholder Theory (Freeman 2010; Freeman and Dmytryiev 2017) that emphasizes the relevance of a firm's relationships with its critical stakeholders, which will lead to better performance. By integrating business and societal considerations, stakeholder value is created, and organizations can make positive and enduring impacts on society (e.g. new jobs creation, pollution reduction, and support to vulnerable people or social and community projects), increase goodwill and trust and promote the access to resources and capabilities it needs to achieve enduring success (Fonseca 2015; McWilliams and Siegel 2011). Moreover, according to Frynas and Yamahaki (2016), other theories also

support the external drivers (e.g. resource-dependence theory) and the internal drivers of sustainability (e.g. the resource-based view (RBV) and agency theory). In the next section, the conceptual background related to the adoption and application of sustainability and I4.0 is presented.

2.1 Adoption of I4.0 in SMEs

Despite the increasing interest of SMEs in I4.0, there is less adoption of automated technologies in their SC operations due to the lack of standardized processes, inefficient knowledge, and high technology costs (Dassisti et al. 2018; Mittal et al. 2018). The adoption of I4.0 in SMEs' SCs faces organizational, environmental, economic, and innovation-related challenges. Sevinç, Gür, and Eren (2018) ranked 14 challenges using analytic hierarchy process (AHP) and analytic network process (ANP), reporting that the high investment cost of I4.0 and unpredictable returns are preventing organizations from adopting it. Prause (2019) developed a technology adoption model by considering 11 intra-organizational factors, among which market uncertainty was the most crucial challenge. External rather than internal factors influence the application of I4.0 technology by SMEs. Li, Fast-Berglund, and Paulin (2019) claimed that the premature stage of I4.0 and organizational culture did not allow full access to resources and information for complete adoption of technologies. Eggers (2020) considered SMEs' short-term strategy a significant challenge affecting the long-term and high investment in technologies. Cerezo-Narv et al. (2019) argued that by identifying the strengths, weaknesses, opportunities, and threats (SWOT), SMEs could employ I4.0. In another industry-based survey study, Masood and Sonntag (2020) found that SMEs in developed and developing countries wanted to adopt the I4.0 but the 'lack of financial support' was the central issue preventing adoption. Agostini and Nosella (2020) reported positive relationships between management support and I4.0 adoption. The study also identified that top management played an essential role in decision-making and coordination between different players. Nwaiwu et al. (2020) examined the importance of organization strategy, organization structure, human resources, competitiveness, and SMEs' operations as adoption challenges. The study showed that the management

of human resources would be a significant part of the transition phase. Moeuf et al. (2020) highlighted the importance of training programs and top management's participation for successful adoption of I4.0 in SMEs. Saad, Bahadori, and Jafarnejad (2021) proposed a methodology that allow the SMEs in evaluating the strength and weakness of technologies associated with I4.0 for their operations. Ghobakhloo and Iranmanesh (2021) describe the resource management and organization competency as major success factor for digital transformation of SMEs and mentioned that the digitization with I4.0 is more complex as compared to traditional automation system due to involvement of multiple dynamic factors.

2.2 Sustainability in SMEs

The establishment of sustainable practices inside SMEs is critical for the growth of the economy. Sustainability in SMEs is described as the principles and action of small, micro, and medium-sized firms conducting their operations in environmentally accountable ways in relation to nationally and internationally recognized societal, ecological, and economic dimensions (Dey et al. 2020). SMEs have become fully cognizant of the influence of their business recognition and relationships with various stakeholders because of increased public awareness of businesses' actions regarding sustainability problems (Siegel et al. 2019). In the context of SMEs, the concept of sustainability has been described as a method of achieving long-term benefits for their firm, since it may help organizations in becoming more cost-effective, manage the business risks, and create new sources of income (Choudhary et al. 2019).

2.3 Adoption of sustainability in SMEs

Several studies concerned the environmental advantages of sustainability in SMEs, but sustainability is yet to be adopted wholly and adequately. Lawrence et al. (2006) explained that an organization should not focus on self-serving sustainability, but they must show concern about others. Masurel (2007) reported that to improve the working conditions, satisfy legislation, and maintain cleanness, SMEs must invest in SC sustainability. Klewitz and Hansen (2014) analyzed sustainable strategic behaviors (resistant, reactive, anticipatory, sustainability-rooted, and innovation-

based) with the process-, organization-, and product-based innovation. SMEs that have adopted innovation-based strategy sought environmental and social change while adopting a sustainability-rooted strategy focused on product, process, and innovation principles.

Further, it was explained that an organization's resistant behavior ignored the environmental pressures, government policies, and anticipatory behavior for future innovation and requirements. Salimzadeh and Courvisanos (2015) reported that SMEs' engagement with SC sustainability would improve product quality and relations with employees and customers. However, factors like the wrong perception of an organization towards low environmental impact, fewer resources, and high cost restrict the adoption of sustainability practices. Hsu, Yuan Chang, and Luo (2017) claimed that SMEs had started considering the environmental factors in their strategy, but it was not easy to deploy them due to limited resources. Siegel et al. (2019) listed 'manpower constraint', 'financial constraint', 'poor management and leadership', 'lack of strategy', and 'internal resistance' as significant barriers for SMEs to achieve sustainability. Eikelenboom and de Jong (2019) underlined the need for a balance between the three pillars (social, economic, and environment) of sustainability for effective, sustainable SC practices while Choudhary et al. (2019) and De Steur, Gellynck, and Canavari (2019) mentioned that it was not easy for SMEs to adopt and change the environmental strategy for sustainability practices due to limited resources. Saqib and Zhang (2021) mentioned that resource and finance management of larger firm is way better than SMEs. Further it was explained that lack the awareness of sustainable practices and its benefits are making the adoption more challenging for SMEs.

2.4 Adoption of sustainability and I4.0 in SMEs

The research in multidisciplinary areas of sustainability and I4.0 is evolving faster than research focusing on distinct areas of I4.0 or sustainability. The integration of sustainable SC and I4.0 has been the focus of SMEs for years, but they failed to adopt these concepts effectively due to different challenges. In a preliminary study to handle the SC sustainability for SMEs using I4.0 and emerging technologies, Bag et al. (2018)

presented a framework that would enable the company's ability to implement I4.0 sustainably. Müller, Buliga, and Ingo Voigt (2018) reported that the implementation of I4.0 to achieve SC sustainability provided more opportunities for large companies than SMEs due to strategy and resource constraints. Birkel et al. (2019) examined that SMEs are always under the threat of resource shortages and loss due to the high investment need for achieving sustainability through I4.0. Yadav et al. (2020) developed an enabler-based SC sustainability framework to increase its adoption using I4.0. Bai et al. (2020) claimed organizations could achieve significant, sustainable practices if technologies related to I4.0 would get evaluated and implemented for each dimension of sustainability. Beier et al. (2020) and Dutta et al. (2020) considered sustainability as an external 'add-on feature' of I4.0 that would support initiatives related to environmental benefits. Although there are many advantages of integrating sustainability and I4.0, SMEs struggle to adopt I4.0 for environmental benefits.

2.5 Adoption barriers of sustainability and I4.0

In this section, Sustainability and I4.0 adoption barriers identified from the literature are listed in Table 1.

Table 1 presents 43 barriers to sustainability and I4.0 identified from 24 unique references. Nine of these 43 barriers were applicable to sustainability: 'lack of relevant technology', 'lack of customer pressure', 'lack of data' 'lack of suitable business process models', 'absence of a green disposal system', 'lack of effective implementation policies', 'lack of environmentally focused capabilities', 'lack of intention to become sustainable', and 'perception of no environmental impact'. Five were applicable to I4.0: 'short-term strategy', 'employees' resistance to change", 'No deployment of digital engineering', 'the need for hardware and software upgrading', 'lack of seamless integration capability', and 29 were applicable to both. These 29 barriers were discussed with industry experts for further classification, addition, and modification from an industrial point of view.

2.6 Research techniques employed for adoption studies in SMEs

Summary of papers published on SMEs' adoption of sustainability and I4.0 are given in Table 2.

Many of the research methods in Table 2 can be considered within the broad discipline of multiple criteria decision making models, highlighting the multidimensional nature of the problem.

2.7 Research gaps

Although many research papers examined sustainability and I4.0 adoption, Müller, Buliga, and Ingo Voigt (2018) assert that the transition of traditional business processes into an automated process is still challenging for SMEs. Most of the current frameworks/models/roadmaps are not related to real issues and lack the implementation mechanisms, making it more difficult for SMEs to adopt them (Mittal et al. 2018). Research conducted by Rossit, Tohmé, and Frutos (2019) demonstrate that SMEs in underdeveloped nations face challenges in achieving sustainability and that businesses desire to employ technology to help them do so. A market report explains that there are 63.4 million small businesses in India that are using energy equivalent to 50 million metric tons of oil per year (Kajol and Shankar 2021) and responsible for 30% of the country's pollution. Although literature discussed the different challenges and issues in implementing the I4.0 and sustainability separately, the weak linkages of the concept of I4.0 and sustainability for SMEs need further investigation (Beier et al. 2020; Cerezo-Narv et al. 2019; Luthra et al. 2020).

In terms of research methodologies, different methods were employed to study the adoption of sustainability and I4.0 in SMEs (see Table 2). The methods like the best-worst, AHP, ANP, and DEMATEL have been used in previous studies. These methods are generally used for getting the best and worst factors, ranking of the factors, or identifying the cause-and-effect factors. The goal of our study is to establish a relationship between the components rather than to prioritize or rank them, which can be done using the ISM technique. However, the employment of the ISM technique for the sustainability com-

Table 1. Barriers to sustainability and I4.0 adoption.

Barriers	Sustainability	I4.0	References
"Lack of suitable tools"	Yes	Yes	Leng et al. (2020)
	Yes	—	Kalmykova et al. (2018)
"Semantic interoperability"	Yes	Yes	Rajput and Singh (2021)
"Lack of relevant technology"	Yes	—	Kirchherr et al. (2018)
"Outdated and less flexible laws and regulations"	Yes	Yes	Leng et al. (2020)
	Yes	Yes	Pham et al. (2019)
	Yes	—	Salimzadeh and Courvisanos (2015)
"Process digitalization"	Yes	Yes	Rajput and Singh (2019)
"Short-term strategy"	—	Yes	Müller, Buliga, and Ingo Voigt (2018)
"Lack of customer pressure"	Yes	—	Salimzadeh and Courvisanos (2015)
"Technology standards and specifications"	Yes	Yes	Rajput and Singh (2019)
"Limited awareness and interest"	Yes	Yes	Leng et al. (2020)
	Yes	Yes	Pham et al. (2019)
	Yes	—	Salimzadeh and Courvisanos (2015)
"Lack of clarity about implementation"	Yes	—	Salimzadeh and Courvisanos (2015)
	Yes	Yes	Bai et al. (2020)
"Lack of cultural feasibility"	Yes	Yes	Pham et al. (2019)
"Lack of data transparency"	Yes	Yes	Leng et al. (2020)
	Yes	Yes	Pham et al. (2019)
"Lack of data"	Yes	—	Kirchherr et al. (2018)
"Lack of government support"	—	Yes	Gu et al. (2019)
	Yes	Yes	Ingaldi and Ulewicz (2020)
	Yes	Yes	Pham et al. (2019)
"Lack of quality infrastructure"	Yes	Yes	Pham et al. (2019)
	Yes	Yes	Rajput and Singh (2019)
"Lack of skilled specialists"	Yes	Yes	Ahmad et al. (2020)
	Yes	Yes	Ingaldi and Ulewicz (2020)
	—	Yes	Ivascu (2020)
	Yes	—	Munsamy, Telukdarie, and Fresner (2019)
"Perception of job insecurity"	Yes	Yes	Birkel et al. (2019)
	—	Yes	Leong et al. (2020)
"Lack of training"	Yes	Yes	Tiwari and Khan (2020)
	Yes	Yes	Ingaldi and Ulewicz (2020)
	Yes	—	Munsamy, Telukdarie, and Fresner (2019)
"Lack of suitable business process models"	Yes	Yes	Birkel et al. (2019)
	Yes	—	Munsamy, Telukdarie, and Fresner (2019)
"Lack of protocols and standards"	Yes	Yes	Rajput and Singh (2019)
"High investment cost"	—	Yes	Ghobakhloo and Fathi (2020)
	Yes	Yes	Ingaldi and Ulewicz (2020)
	—	Yes	Ivascu (2020)
	Yes	Yes	Rajput and Singh (2019)
	—	Yes	Gu et al. (2019)
"Lack of privacy, integrity, confidentiality, and trust"	Yes	Yes	Leng et al. (2020)
	Yes	—	Tiwari et al. (2019)

(Continued)

Table 1. (Continued).

Barriers	Sustainability	I4.0	References
"Lack of knowledge"	Yes	Yes	Bai et al. (2020)
"Top management support"	Yes	Yes	Ahmad et al. (2020)
"Lack of resources"	Yes	Yes	Birkel et al. (2019)
	—	Yes	Cerezo-Narv et al. (2019)
"Employees' resistance to change"	—	Yes	Ivascu (2020)
"Lack of Integration and adoption in the system"	Yes	Yes	Ahmad et al. (2020)
	Yes	Yes	Bai et al. (2020)
	—	Yes	Jabbour et al. (2020)
	—	Yes	Gu et al. (2019)
"Lack of energy balance system"	Yes	Yes	Birkel et al. (2019)
"Lack of specialized support"	Yes	Yes	Ingaldi and Ulewicz (2020)
"Lack of adequate environmental sustainability"	Yes	Yes	Ingaldi and Ulewicz (2020)
"Lack of technological infrastructure"	Yes	Yes	Ingaldi and Ulewicz (2020)
"Employees' competence and skills in the market"	Yes	Yes	Ingaldi and Ulewicz (2020)
"Lack of understanding of the organizational goals"	Yes	Yes	Ingaldi and Ulewicz (2020)
"Absence of a green disposal system"	Yes	—	Karupiah et al. (2020)
"Lack of effective implementation policies"	Yes	—	Chofreh et al. (2020)
"No deployment of digital engineering"	—	Yes	Belinski et al. (2020)
"The need for hardware and software upgrading"	—	Yes	Leng et al. (2020)
"Lack of environmentally focused capabilities"	Yes	—	Lawrence et al. (2006)
"Lack of intention to become sustainable"	Yes	—	Leng et al. (2020)
"Cost and complexity"	Yes	Yes	Ahmad et al. (2020)
"Less vendor services"	Yes	Yes	Ahmad et al. (2020)
"Perception of no environmental impact"	Yes	—	Lawrence et al. (2006)
"Lack of seamless integration capability"	—	Yes	Ghobakhloo and Fathi (2020)

ponent, which analyses the perspectives of different SMEs, is limited. The addressed research disparities suggest the need for a further study and development of industry-oriented framework that could present barriers of sustainability and I4.0 together for strategic planning and its systematic implementation using ISM methods in SMEs.

3. Research methodology

To achieve the research objectives of this study, initially, the adoption barriers of I4.0-sustainability practices for SMEs are established by an extensive literature review. The identified barriers were discussed with a panel of experts, including SME practitioners and academicians from India. Later, the finalized barriers are presented to three Indian origin SMEs for further validation. The selection of Indian SMEs is based on the fact that most of the literature was focused on developed countries, and minimal insights were available related to organizations in developing countries (Rahman et al. 2020). Then a comparative study of three SME organizations is carried out using three different ISM models. Finally, MICMAC analysis is performed in which the identified barriers are clustered into four groups as per their dependence power and driving power.

3.1 Interpretive structural modeling

'Interpretive Structural Modeling (ISM)' is an interactive process that represents the complex system in a systematic way (Warfield 1974). It has been used to find the interrelationships between criteria/factors/barriers and structure the related concepts for any particular activity (Kumar et al. 2021b). The ISM method includes the following steps:

Step 1: Construct the 'structural self-interaction matrix (SSIM)' utilizing the symbol 'V', 'A', 'X', and 'O' with the help of experts. The SSIM matrix represents the relation between different barriers.

V: when barrier 'i' is influencing barrier 'j'

A: when barrier 'i' is influenced by barrier 'j'

X: when both barrier 'i' and 'j' influenced each other

O: when no connect among 'i' and 'j'

Step 2: Convert the SSIM into 'initial reachability matrix (IRM)' using the rules in Table 3:

Step 3: Prepare the 'final reachability matrix (FRM)'. In this step a transitivity check is performed to get FRM from IRM. As per the rule of transitivity, if 'i' affects 'j' and 'j' affects 'k', 'i' will also affect 'k'. This process helps in establishing the indirect relation and removing the biasness (Kumar et al. 2021c).

Step 4: Level partitioning is done in this step using FRM. For each barrier, we develop a 'reachability set' (RS), an 'antecedent set' (AS), and an 'intersection set' (IS). The 'reachability set' of each barrier is formed using the elements present in that row, including itself. The 'antecedent set' of each barrier is formed using the elements present in that column, including itself. The 'intersection set' contains a common element of 'reachability set' and 'antecedent set'. The barrier(s) for which elements in 'reachability set' and 'intersection set' are the same would be the part of partition-*l*. These barriers are then removed from the list, and the same process is repeated till all the barriers are assigned in partitions.

Step 5: Construct the digraph using the partition level. Placed the barriers of *partition-l* at the top of ISM model and so on.

3.2 MICMAC analysis

We perform the MICMAC analysis by dividing the barriers into four clusters based on their driving power and dependence power. The four clusters have been named as 'Autonomous', 'Dependent', 'Linkage', and 'Independent'. Elements come under the 'autonomous cluster' with low dependence and driving power, and they do not connect with the system. Elements related to the 'dependent cluster' are having low driving and high dependence power. They generally appear at the top of the ISM model. Linkage elements have high driving and dependence power, while the independent cluster elements have high driving and low dependence power. They are considered as the base of the ISM model and generally found at the bottom level.

4. Data collection and analysis

To examine and validate the barriers identified from the literature, expert discussions were conducted. A total of 15 experts having experience

Table 2. Research methods employed for studies in SMEs.

Author (s)	Research Methods	Focus of research
Agostini and Nosella (2020)	The survey, regression analysis	I4.0
Bai et al. (2020)	Hesitant fuzzy set, cumulative prospect theory, VIKOR	Sustainability & I4.0
Masood and Sonntag (2020)	Survey	I4.0
Moeuf et al. (2020)	Delphi	I4.0
Yadav et al. (2020)	Robust Best Worst	Sustainability & I4.0
Ghobakhloo (2019)	ISM, MICMAC	Sustainability & I4.0
Singh et al. (2019)	Grey DEMATEL	Sustainability & I4.0
Steur, Gellynck, and Canavari (2019)	Survey	Sustainability
Sevinç, Gür, and Eren (2018)	AHP, ANP	I4.0
Shibin et al. (2018)	TISM; MICMAC; CFA; SEM	Sustainability & I4.0
Hsu, Yuan Chang, and Luo (2017)	QFD, FDM, FEAHP, TOPSIS	Sustainability
Salimzadeh and Courvisanos (2015)	Literature search	Sustainability
Lawrence et al. (2006)	Survey	Sustainability

Table 3. SSIM to IRM conversion rule.

(i, j) in SSIM	(i, j) in IRM	(j, i) in IRM
V	1	0
A	0	1
X	1	1
O	0	0

of more than 5 years were selected for this study (**demographic details are shown in Appendix**). Three experts were from the 'Ministry of Micro Small & Medium Enterprises India' associated with the policy formation team. Three experts were from the 'research and development' department working for the development of Indian SMEs, and nine experts were from three automotive SMEs located in India named 'A', 'B', and 'C'. The identified barriers were discussed with these experts for further modification. After brainstorming and three rounds of discussion with experts, it was found that the identified barriers can be classified into 12 significant barriers, and sub barriers (see [Table 4](#)). A matrix consisting of 12 adoption barriers was provided to each company's experts to fill and develop the SSIM. In the rest of the paper, case A, case B, and case C references are used for these three SMEs. SSIM obtained for case A, case B and case C are shown in **Appendix**.

- (1) **Case A:** 28 years old connecting rod manufacturing company has the mission to deliver

a quality product. It has a semi-automatic system for testing and detection of components. This organization is practicing the lean sustainable development program and transforming its work environment towards more automation.

- (2) **Case B:** It is a 21-year-old manufacturer of cylinder liner and piston. This company is now committed to invest in the latest innovation and transformation to ensure flawless processes and eco-friendly products. This organization is aiming to start investment in I4.0 and sustainable practices.
- (3) **Case C:** It is a 28-year-old crankshaft manufacturing company having the aim to provide innovative, cost-effective, and environment friendly goods. This company always values safety, sustainability, and Kaizen in their business practices. This organization has been using waste reduction and sustainable practices but now planning to invest in I4.0. The more details of these organizations are provided in the **Appendix** Section.

Table 4. Proposed list of barriers.

Barriers	Sub-barriers	Description	References
Lack of Infrastructure (LI)	Physical and IT infrastructure	Limited technological and physical infrastructure available that cannot be transformed and integrate the modern-day practices.	Ingaldi and Ulewicz (2020); Pham et al. (2019)
Lack of Awareness (LA)	Perception of no environmental impact, Perception of job insecurity, no customer pressure	Sustainability and I4.0 are a comparatively new concept, and there is a common understanding of the real impact and contribution of these concepts. Managers are also perceiving little financial benefit from environmental investments.	Birkel et al. (2019); Leong et al. (2020); Lawrence et al. (2006)
Lack of Cultural Feasibility (LCF)	Resistance to change a tradition followed by business and communities, social ethics, and value	Workers' performance may be linked to accessibility to new working conditions and could be the reason to adopt the change. Moral concern, emotional connection with existing systems are the challenges for adoption.	Pham et al. (2019)
Lack of Resources (LR)	Tools, suitable technology, low energy balance, data unavailability, less alternative, resource unavailability, vendor services	Plenty of resources are not supported and cannot illustrate the appropriate time and expense for sustainability and I4.0 adoption. Despite the availability of funding to implement new technology with a view to sustainability and Industry 4.0, service providers' unavailability is becoming a big obstacle.	Kalmykova et al. (2018); Birkel et al. (2019); Ahmad et al. (2020); Leng et al. (2020)
Lack of Employee's Competence/ expertise (LEC)	Less trained and skilled workforce, no training program, sustainability knowledge	Low insight into policies to address environmental issues. The concept is new to the systems, meaning that workers need to learn new skills and continuously update existing skills.	Ivascu (2020); Munsamy, Telukdarie, and Fresner (2019)
Lack of Government and Organizational Support (LGOS)	Financial investment, organization vision, and goal, outdated and less flexible policies and regulation, no protocols and standards, no incentives/subsidies/loan	Government and organization support is essential for implementing costly types of machinery in the financing, incentives, preparation, etc. Present regulations are out of date to convince the adoption of a new philosophy. In general, the management team is not aware of how important it is to transform companies to succeed.	Leng et al. (2020); Rajput and Singh (2019)
Low Cost of Virgin Product (LCVP)		Virgin material is available in the market at a very cheap cost.	Expert opinion
Lack of implementation Plan and Policy for Sustainability (LPPS)	No focused environmental capabilities, short term strategy, no conceptual guidance for integration and adoption in the system	Appropriate guidelines for the adoption of sustainable practices are not available. Innovations continue to be incorporated into conventional manufacturing processes, making reliability problems much more relevant.	Müller, Buliga, and Ingo Voigt (2018); Bai et al. (2020)
Lack of Trust (LT)	Privacy, data transparency, confidentiality	Malfunctioning of technology is the biggest issue for SMEs to trust with high investment.	Leng et al. (2020); Tiwari et al. (2019)
Lack of Business Model (LBM)	Poor research and development, fewer integration capabilities, technological integrity	Established business models cannot integrate with the current structure. The absence of seamless convergence of traditional enterprise networks, facilities, and processes with modern networking systems into a single interconnected digital environment that provides a seamless stream of data has proved to be extremely difficult.	Munsamy, Telukdarie, and Fresner (2019); Jabbour et al. (2020)
Lack of Intention to Sustainability (LIS)	No hardware and software upgradation, deployment of digital engineering, no support from stakeholder for the digital environment	Interaction and contact with all partners during the implementation process remain a significant challenge. The interest of the stakeholder will be the most significant factor to be included in this implementation.	Belinski et al. (2020); Leng et al. (2020)
High Investment Cost (HIC)		Cost is often the first problem in the implementation of any equipment, device, or upgrade. I4.0 appears to be exceptionally costly. Benefits exist, and investment cannot be measured quickly and precisely. The company would have to bear the expense of replacing some ancient physical structures and today is digital equipment/software systems.	Ahmad et al. (2020)

Table 5. Case A-FRM.

Barriers	LI	LA	LCF	LR	LEC	LGOS	LCVP	LPPS	LT	LBM	LIS	HIC	Driving power
LI	1	0	0	0	0	0	1	0	1	1	0	0	4
LA	1	1	1	0	1	1	1	0	1	1	0	0	8
LCF	1	0	1	0	0	0	0	0	1	0	0	0	3
LR	1	1	1	1	1	1	1	1	1	1	1	1	12
LEC	1	1	0	0	1	0	1	1	1	1	0	1	8
LGOS	1	1	1	0	0	1	1	0	1	1	1	1	9
LCVP	1	1	1	0	1	1	1	1	1	1	1	1	11
LPPS	1	1	1	0	1	0	1	1	1	1	0	1	9
LT	1	1	0	0	1	1	1	0	1	1	0	0	7
LBM	1	0	0	0	0	0	1	0	1	1	0	0	4
LIS	1	1	1	0	0	0	1	0	1	1	1	0	7
HIC	1	1	1	0	0	0	1	0	1	1	0	1	7
Dependence	12	9	8	1	6	5	11	4	12	11	4	6	

Table 6. Case A- partition.

	Reachability set	Antecedent set	Intersection set	Partition
LI	LI, LCVP, LT, LBM	LI, LA, LCF, LR, LEC, LGOS, LCVP, LPPS, LT, LBM, LIS, HIC	LI, LCVP, LT, LBM	I
LA	LI, LA, LCF, LEC, LGOS, LCVP, LT, LBM	LA, LR, LEC, LGOS, LCVP, LPPS, LT, LIS, HIC	LA, LEC, LGOS, LCVP, LT	III
LCF	LI, LCF, LT	LA, LCF, LR, LGOS, LCVP, LPPS, LIS, HIC	LCF	II
LR	LI, LA, LCF, LR, LEC, LGOS, LCVP, LPPS, LT, LBM, LIS, HIC	LR	LR	VI
LEC	LI, LA, LEC, LCVP, LPPS, LT, LBM, HIC	LA, LR, LEC, LCVP, LPPS, LT	LA, LEC, LCVP, LPPS, LT	V
LGOS	LI, LA, LCF, LGOS, LCVP, LT, LBM, LIS, HIC	LA, LR, LGOS, LCVP, LT	LA, LGOS, LCVP, LT	V
LCVP	LI, LA, LCF, LEC, LGOS, LCVP, LPPS, LT, LBM, LIS, HIC	LI, LA, LR, LEC, LGOS, LCVP, LPPS, LT, LBM, LIS, HIC	LI, LA, LEC, LGOS, LCVP, LPPS, LT, LBM, LIS, HIC	III
LPPS	LI, LA, LCF, LEC, LCVP, LPPS, LT, LBM	LR, LEC, LCVP, LPPS	LEC, LCVP, LPPS	IV
LT	LI, LA, LEC, LGOS, LCVP, LT, LBM	LI, LA, LCF, LR, LEC, LGOS, LCVP, LPPS, LT, LBM, LIS, HIC	LI, LA, LEC, LGOS, LCVP, LT, LBM	I
LBM	LI, LCVP, LT, LBM	LI, LA, LR, LEC, LGOS, LCVP, LPPS, LT, LBM, LIS, HIC	LI, LCVP, LT	I
LIS	LI, LA, LCF, LCVP, LT, LBM, LIS	LR, LGOS, LCVP, LIS	LCVP, LIS	IV
HIC	LI, LA, LCF, LCVP, LT, LBM, HIC	LR, LEC, LGOS, LCVP, LPPS, HIC	LCVP, HIC	IV

Table 7. Case B-FRM.

Barriers	LI	LA	LCF	LR	LEC	LGOS	LCVP	LPPS	LT	LBM	LIS	HIC	Driving power
LI	1	1	1	1	0	0	1	0	1	1	0	0	7
LA	1	1	1	0	0	0	1	0	1	1	0	0	6
LCF	1	1	1	1	1	1	1	1	1	1	1	1	12
LR	1	1	1	1	1	1	1	1	1	1	1	1	12
LEC	1	1	0	0	1	0	1	1	1	1	1	1	9
LGOS	1	1	0	0	0	1	1	0	1	1	1	1	8
LCVP	1	1	0	0	1	1	1	1	1	1	1	1	10
LPPS	1	1	1	0	1	0	1	1	1	1	1	1	10
LT	1	1	1	0	1	1	1	0	1	1	0	0	8
LBM	1	0	0	0	0	0	1	0	1	1	0	0	4
LIS	1	1	1	0	0	0	0	0	1	1	1	0	6
HIC	1	1	0	0	0	0	0	0	1	1	0	1	5
Dependence	12	11	7	3	6	5	10	5	12	12	7	7	

4.1 Data analysis and result

In data analysis all (for case A, case B and Case C) the SSIM are converted into IRM using rules shown in Table 3. Then the IRM is converted into FRM (see Table 5, Table 7, Table 9) to remove the transitivity as explained in Step 3. From FRM, the level partition (see Table 6, Table 8, Table 10) for each case was performed to build the ISM

model. The detail of IRM and level partitions are shown in **Appendix**.

4.1.1 Case A

The diagram of barriers for case A is shown in Figure 2.

The developed model can be divided into low-level barriers, middle-level barriers, and top-level barriers. At

Table 8. Case B partition.

	Reachability set	Antecedent set	Intersection set	Partition
LI	LI, LA, LCF, LR, LCVP, LT, LBM	LI, LA, LCF, LR, LEC, LGOS, LCVP, LPPS, LT, LBM, LIS, HIC	LI, LA, LCF, LR, LCVP, LT, LBM	I
LA	LI, LA, LCF, LCVP, LT, LBM	LI, LA, LCF, LR, LEC, LGOS, LCVP, LPPS, LT, LIS, HIC	LI, LA, LCF, LCVP, LT	II
CF	LI, LA, LCF, LR, LEC, LGOS, LCVP, LPPS, LT, LBM, LIS, HIC	LI, LA, LCF, LR, LPPS, LT, LIS	LI, LA, CF, LR, LPPS, LT, LIS	VI
LR	LI, LA, CF, LR, LEC, LGOS, LCVP, LPPS, LT, LBM, LIS, HIC	LI, CF, LR	LI, CF, LR	VI
LEC	LI, LA, LEC, LCVP, LPPS, LT, LBM, LIS, HIC	LCF, LR, LEC, LCVP, LPPS, LT	LEC, LCVP, LPPS, LT	V
LGOS	LI, LA, LGOS, LCVP, LT, LBM, LIS, HIC	LCF, LR, LGOS, LCVP, LT	LGOS, LCVP, LT	IV
LCVP	LI, LA, LEC, LGOS, LCVP, LPPS, LT, LBM, LIS, HIC	LI, LA, LCF, LR, LEC, LGOS, LCVP, LPPS, LT, LBM	LI, LA, LEC, LGOS, LCVP, LPPS, LT, LBM	IV
LPPS	LI, LA, LCF, LEC, LCVP, LPPS, LT, LBM, LIS, HIC	LCF, LR, LEC, LCVP, LPPS	LCF, LEC, LCVP, LPPS	IV
LT	LI, LA, LCF, LEC, LGOS, LCVP, LT, LBM	LI, LA, LCF, LR, LEC, LGOS, LCVP, LPPS, LT, LIS, HIC	LI, LA, LCF, LEC, LGOS, LCVP, LT, LBM	I
LBM	LI, LCVP, LT, LBM	LI, LA, LCF, LR, LEC, LGOS, LCVP, LPPS, LT, LIS, HIC	LI, LCVP, LT, LBM	I
LIS	LI, LA, LCF, LT, LBM, LIS	LCF, LR, LEC, LGOS, LCVP, LPPS, LIS	LCF, LIS	III
HIC	LI, LA, LT, LBM, HIC	LCF, LR, LEC, LGOS, LCVP, LPPS, HIC	HIC	III

Table 9. Case C-FRM.

Barriers	LI	LA	LCF	LR	LEC	LGOS	LCVP	LPPS	LT	LBM	LIS	HIC	Driving power
LI	1	0	0	0	0	0	1	0	1	1	0	0	4
LA	1	1	1	0	1	1	1	0	1	1	0	0	8
LCF	1	0	1	0	0	0	0	0	1	0	0	0	3
LR	1	1	1	1	1	1	1	1	1	1	1	1	12
LEC	1	1	0	0	1	0	1	1	1	1	0	1	8
LGOS	1	1	1	0	0	1	1	0	1	1	1	1	9
LCVP	1	1	0	0	1	1	1	1	1	1	1	1	10
LPPS	1	1	1	0	1	0	1	1	1	1	0	1	9
LT	1	0	0	0	1	1	1	0	1	1	0	0	6
LBM	1	0	0	0	0	0	1	0	1	1	0	0	4
LIS	1	1	1	0	0	0	1	0	1	1	1	0	7
HIC	1	1	1	0	0	0	1	0	1	1	0	1	7
Dependence	12	8	7	1	6	5	11	4	12	11	4	6	

Table 10. Case C partition.

	Reachability set	Antecedent set	Intersection set	Partition
LI	LI, LCVP, LT, LBM	LI, LA, LCF, LR, LEC, LGOS, LCVP, LPPS, LT, LBM, LIS, HIC	LI, LCVP, LT, LBM	I
LA	LI, LA, LCF, LEC, LGOS, LCVP, LT, LBM	LA, LR, LEC, LGOS, LCVP, LPPS, LIS, HIC	LA, LCF, LEC, LGOS, LCVP	II
LCF	LI, LCF, LT	LA, LCF, LR, LGOS, LPPS, LIS, HIC	LCF	II
LR	LI, LA, LCF, LR, LEC, LGOS, LCVP, LPPS, LT, LBM, LIS, HIC	LR	LR	V
LEC	LI, LA, LEC, LCVP, LPPS, LT, LBM, HIC	LA, LR, LEC, LCVP, LPPS, LT	LA, LEC, LCVP, LPPS, LT	IV
LGOS	LI, LA, LCF, LGOS, LCVP, LT, LBM, LIS, HIC	LA, LR, LGOS, LCVP, LT	LA, LGOS, LCVP, LT	IV
LCVP	LI, LA, LEC, LGOS, LCVP, LPPS, LT, LBM, LIS, HIC	LI, LA, LR, LEC, LGOS, LCVP, LPPS, LT, LBM, LIS, HIC	LI, LA, LEC, LGOS, LCVP, LPPS, LT, LBM, LIS, HIC	I
LPPS	LI, LA, LCF, LEC, LCVP, LPPS, LT, LBM, HIC	LR, LEC, LCVP, LPPS	LEC, LCVP, LPPS	IV
LT	LI, LEC, LGOS, LCVP, LT, LBM	LI, LA, LCF, LR, LEC, LGOS, LCVP, LPPS, LT, LBM, LIS, HIC	LI, LEC, LGOS, LCVP, LT, LBM	I
LBM	LI, LCVP, LT, LBM	LI, LA, LR, LEC, LGOS, LCVP, LPPS, LT, LBM, LIS, HIC	LI, LCVP, LT, LBM	I
LIS	LI, LA, LCF, LCVP, LT, LBM, LIS	LR, LGOS, LCVP, LIS	LCVP, LIS	III
HIC	LI, LA, LCF, LCVP, LT, LBM, HIC	LR, LEC, LGOS, LCVP, LPPS, HIC	LCVP, HIC	III

the bottom level, there are barriers related to lack of resources (LR), lack of employee's competence/expertise (LEC), and lack of government and organization support (LGOS). These barriers are the foundation of

the ISM model that is driving the other barriers above them. Policymakers need to pay more attention to these barriers if they plan to transform the business structure for adopting Sustainability and I4.0 practices.

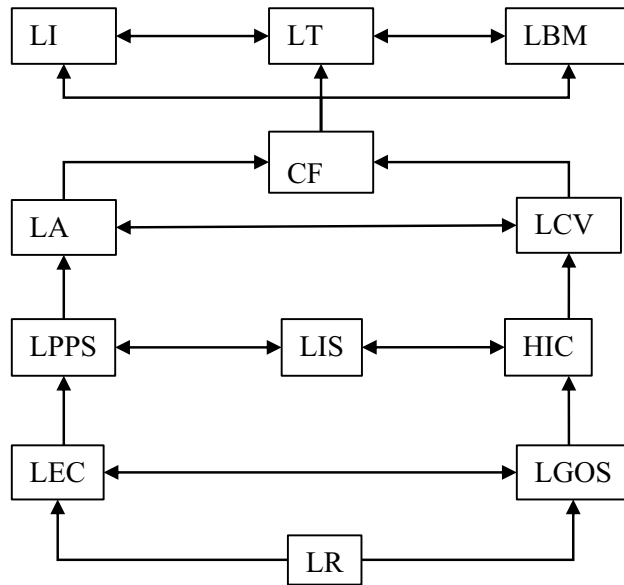

Figure 2. Diagram of Case A.

Driving Power ↑	12	LR											
	11							LCVP					
	10	Independent Barrier					Linkage Barrier						
	9			LPPS	LGOS								
	8					LEC			LA				
	7			LIS		HIC							LT
	6												
	5												
	4										LBM	LI	
	3								LCF				
	2	Autonomous Barrier					Dependent Barrier						
	1												
	1	2	3	4	5	6	7	8	9	10	11	12	
	Dependence Power →												

Figure 3. Driver-dependence diagram of Case A.

Lack of awareness (LA), Lack of Cultural feasibility (LCF), low cost of the virgin product (LCVP), lack of implementation plan and policy for sustainability (LPPS), lack of intention to sustainability (LIS), and high investment cost (HIC) comes under middle-level barriers. These barriers are driven by the bottom-level barrier and

can influence the barriers above them. Top-level barriers consist of a lack of infrastructure (LI), lack of trust (LT), and lack of business model (LBM). These barriers have very low influencing power compared to other barriers in the model and can be eliminated easily once the bottom and low-level barriers are removed.

The result of MICMAC analysis for case 'A' is shown in Figure 3. No barrier appeared in the autonomous cluster that shows that all the selected barriers are relevant for case 'A' and would impact the adoption strategy of Sustainability and I4.0. Three barriers (lack of infrastructure (LI), Lack of Cultural feasibility (LCF), and lack of business model (LBM)) are identified as dependent clusters. Due to low dependence and driving power, the dependent cluster element generally appears on the top of the model. The lack of awareness (LA), low cost of the virgin product (LCVP), and lack of trust (LT) appeared in the linkage cluster during analysis of a case 'A'. Barriers fall under the linkage cluster must be handled carefully due to unstable and volatile nature. The decision related to these barriers can influence the overall transformation process of organization. Lack of resources (LR), lack of employee's competence/expertise (LEC), lack of government and organization support (LGOS), lack of implementation plan and policy for sustainability (LPPS), lack of intention to sustainability (LIS), and high investment cost (HIC) are the most significant barriers as they fall under the independent cluster. Independent clusters need special attention from decision-makers as they are a driver for other barriers.

4.1.2 Case B

The diagram of the case 'B' is shown in Figure 4. At the bottom level, there are barriers related to

lack of resources (LR), Lack of Cultural feasibility (LCF), and lack of employee's competence/expertise (LEC). Decision-makers of case 'B' must be more concerned about these barriers for significantly adopting the Sustainability and I4.0 practices. Lack of awareness (LA), lack of government and organization support (LGOS), low cost of the virgin product (LCVP), lack of implementation plan and policy for sustainability (LPPS), lack of intention to sustainability (LIS), and high investment cost (HIC) comes under middle-level barriers. These barriers are driven by the bottom-level barrier and can influence the barriers above them. Top-level barriers consist of a lack of infrastructure (LI), lack of trust (LT) and lack of business model (LBM). These barriers are having very low influencing power as compared to other barriers in the model.

The result of MICMAC analysis for case 'B' is shown in Figure 5. In this case, no barrier appeared in the autonomous cluster. Four barriers (lack of awareness (LA), lack of business model (LBM), lack of intention to sustainability (LIS), and high investment cost (HIC)) is identified as a dependent barrier. The decision related to linkage barriers can influence the adoption process Sustainability and I4.0 for this organization. The lack of infrastructure (LI), Lack of Cultural feasibility (LCF), low cost of the virgin product (LCVP), and lack of trust (LT) appeared in the linkage cluster. Following the MICMAC

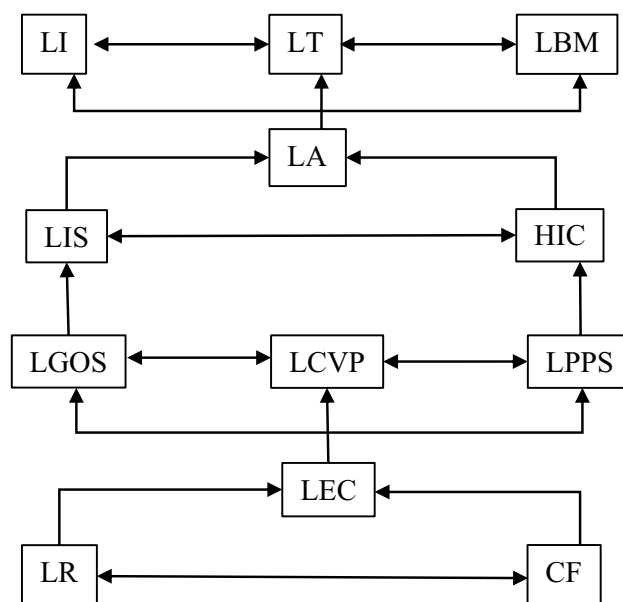

Figure 4. Diagram of Case B.

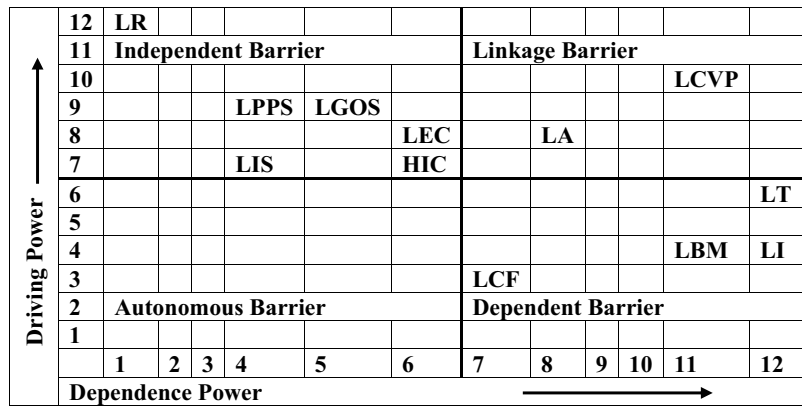

Figure 7. Driver-dependence diagram of Case C.

cost of the virgin product (LCVP) appeared in the linkage cluster during analysis. The decision related to the linkage cluster can influence the other barriers and adoption process due to high driving and dependence power. Lack of resources (LR), lack of employee’s competence/expertise (LEC), lack of government and organization support (LGOS), lack of implementation plan and policy for sustainability (LPPS), lack of intention to sustainability (LIS), and high investment cost (HIC) are the most significant barriers for the case ‘C’ that is placed in an independent cluster.

5. Discussion

This research addressed three SMEs’ cases to understand their views and perspectives to simplify the adoption barriers of sustainability and I4.0. The barriers were derived from the literature and finalized with the help of experts’ opinion and input. Further, the barriers were analyzed using the ISM approach to find the interrelation among them. The analysis of ISM resulted in a different hierarchy for three SMEs. The way barriers are placed on a different level and in the cluster for different SMEs shows a different kind of strategy and the development under SMEs related to

sustainability and I4.0 adoption. The difference in the organizational structure and operational practices, of SMEs resulted into three different ISM model. A comparative discussion of results is shown in Table 11 to get the common barriers (see Table 11) among three SME.

Lack of resources (LR) and lack of employees’ competence/expertise (LEC) emerged as the most dominating barrier for adopting sustainability and I4.0 in all the cases. These two barriers appear at the bottom level of the hierarchy and consistently found their place in the independent cluster. Therefore, it is also evident that management should develop, implement, and prepare strategies carefully to direct decisions related to the workforce resources and hiring to promote SMEs’ transformation. This finding is in line with previous studies by (Dey et al. 2020; Raj et al. 2020) that highlight the importance of SMEs’ resources. Belinski et al. (2020) and Ingaldi and Ulewicz (2020) report the significance of training and learning for industry professionals and academic students to tackle the barrier of lack of expert and skilled workforce to adopt to the fast-changing technical environment. The previous research argues that government and organization ought to strengthen

Table 11. Summary of barriers in ISM and cluster analysis.

ISM model analysis				
	A	B	C	Common
Top level	LI, LT, LBM	LI, LT, LBM	LI, LCVP, LT, LBM	LI, LT, LBM
Middle level	LA, LCF, LCVP, LPPS, LIS, HIC	LA, LGOS, LCVP, LPPS, LIS, HIC	LA, LCF, LIS, HIC	LA, LIS, HIC
Bottom level	LR, LEC, LGOS	LCF, LR, LEC	LR, LEC, LGOS, LPPS	LR, LEC
Cluster analysis				
Autonomous	---	---	---	---
Independent	LR, LEC, LGOS, LPPS, LIS, HIC	LR, LEC, LGOS, LPPS	LR, LEC, LGOS, LPPS, LIS, HIC	LR, LEC, LGOS, LPPS
Linkage	LA, LCVP, LT	LI, LCF, LCVP, LT	LA, LCVP	LCVP
Dependent	LI, LCF, LBM	LA, LBM, LIS, HIC	LI, LCF, LT, LBM	LBM

norms and legislation and reduce political and economic barriers to encourage SMEs' transformation. This result is supported by the observations of the previous research work by Shibin et al. (2018) and Karuppiah et al. (2020) who state that in rising economies, institutional impediments and constraints necessitate innovative supply chain models that balance economic, social, and environmental concerns with government laws and regulations. In case 'A' and case 'C', the lack of government and organization support (LGOS) appeared as more dominant as compared to the case 'B'. This may be because the SME belongs to case 'B' have already started the technology implementation and have required things like legal papers, experts, a well-defined project, etc. to get support from the government.

Furthermore, the SME associated with case 'B' is in the transformation stage and invested in the latest innovation, are facing Cultural feasibility, as they appear more critical than LGOS. This outcome is aligned with the study of Pham et al. (2019) that asserts the social-cultural limitation is a critical barrier that requires government intervention while implementing new concepts and ideas. Lack of awareness (LA), lack of intention to sustainability (LIS), and high investment cost (HIC) are the other influencing barriers at the bottom level recognized in the context of SMEs. Reducing these barriers' impact is a very challenging task as it may include the awareness program for both consumers and producers when economies and market shifts in the direction of sustainability. The organization must provide customers with a variety of environmentally sustainable goods and services. In this respect, research organizations should use and develop various methods and services to increase the acceptance of sustainability and I4.0 (Salimzadeh and Courvisanos 2015). The high investment cost is considered less necessary in this analysis than other barriers, which is aligned with the findings of Steur, Gellynck, and Canavari (2019), who discuss that in case of innovation management, financial investment have importance as compared to labor investment and level of satisfaction. In the ISM model, lack of implementation plan and policy for sustainability (LPPS) has been considered as the most significant barrier that is supported by the findings of Das and Rangarajan (2019) that state that policy strategies and competitive synergies have a positive impact on the sustainability competence of an organization.

Literature reported that SMEs' practitioners are struggling with their short-term strategy due to small size business and less predictable benefits. Lack of infrastructure (LI), lack of trust (LT), and lack of business model (LBM) are identified as the least significant barrier in the context of the adoption of sustainability and I4.0 in SMEs. Some barriers are identified to be more influential than others, but the result of MICMAC shows that all the barriers selected for the studies are valid as no barriers fall under the autonomous cluster.

6. Conclusion

The adoption of sustainable practices and I4.0 has become the primary agenda for SME's SC practitioners to get a competitive advantage in the global market. This study is carried out to identify the adoption barriers of sustainability and I4.0 in SMEs. Based on a comprehensive literature search and discussion with experts from three SMEs, 12 critical barriers were selected for this study. Furthermore, the study examined the interrelationship between the barriers using the ISM approach. The ISM results are complemented with MICMAC to classify barriers into four groups: independent, dependent, linkage, and autonomous. The study highlights the common trend of these barriers for different SMEs for effective implementation of adoption and reduction of failures in the process.

The study added value in the existing literature by complementing and extending the emerging role of I4.0 (Masood and Sonntag 2020; Moeuf et al. 2020) as well as the role of sustainability (Ramanathan et al. 2020; Steur, Gellynck, and Canavari 2019) in SMEs by developing a framework of adoption barriers of integrated sustainability and Industry 4.0.

6.1 Managerial implications

This study's findings provide insights to practitioners in SMEs about the challenges faced in adopting sustainability and I4.0 practices. SMEs have been regularly facing issues related to strategy development (Siegel et al. 2019). The presented analysis can be illuminated and interpreted in short-, medium- and long- term action for strategy development. The organization, those planning to adopt sustainability and I4.0 shortly, can develop the strategies like case 'A' and case 'C'. These organizations need to

follow the existing government rules and regulations and prepare the full project plan to get the support of the government. To promote the adoption of sustainability and I4.0, the government must create incentives and rewards for organizations, and organizations must plan the same for their workforce. The SMEs that have already started the adoption process like case 'B' need to focus more on workers' training and skill-building to reduce the fear of culture change and job loss. Following a training and skills development program, companies should offer their employees some sort of bonus or promotion based on their knowledge of sustainability and I4.0. Analysis of the common trend of barriers would help to develop the short-, medium- and long- term strategy for SMEs. As bottom-level barriers are the foundation and driving the other barriers, they need to be removed first. These barriers can be part of a short-term strategy and can be easily eliminated due to their independent nature (see Table 11). The study's findings advise that businesses should invest in cutting-edge tools and technology that are both environmentally friendly and energy efficient. The use of vendors that can supply timely services would be more beneficial in reducing the impact of a lack of resources. The middle-level barrier is the link between the low-level and top-level barriers, so the research and development sector need to pay more attention while designing the strategy for middle-level barriers. A small change in the strategy related to middle-level barriers and barriers in the linkage cluster may impact the complete adoption process. These barriers can be part of medium-term planning. Barriers in the dependent cluster and at the top-level can be considered for long-term strategy as these barriers will take some time to remove.

6.2 Limitations and future research directions

Some drawbacks and questions resulting from this analysis offer more grounds for future analysis. The location and type of industry influence SMEs' decision-making on sustainable activities (Dutta et al. 2020; Steur, Gellynck, and Canavari 2019). Because the current study is focused on Indian SMEs, it is necessary to understand the results in the context of other countries and to evaluate them as a benchmark in future research on SMEs. During this study,

employees from the R&D department with decision-making authority were appropriate for discussion and data gathering, so the study's output is based on input from a restricted group of specialists. So, the same study can be further extended with different MCDM techniques like DEMATEL, best-worst analysis, or ANP to rank the importance of these barriers. In a recent study, El Baz et al. (2022) use the best and worst method to rank sustainability-oriented Industry 4.0 projects to express the essential importance of driving factors in such processes. The study can also be stretched to investigate if structural equation modelling can be implemented with a large number of respondents in an Indian context, as Jayashree et al. (2022) did for Malaysian firms. Further comments from various sectors should be obtained and analyzed to generalize research findings using different MCDM techniques.

Given the limitations stated above, this research work sheds light on sustainability and I4.0 practices in SMEs by highlighting the complexity of barriers and adopting sustainable supply chain practices through the help of I4.0 technologies.

Disclosure statement

No potential conflict of interest was reported by the author(s).

ORCID

Shashank Kumar  <http://orcid.org/0000-0003-0841-987X>

Rakesh D. Raut  <http://orcid.org/0000-0002-0469-1326>

Emel Aktas  <http://orcid.org/0000-0003-3509-6703>

Balkrishna E. Narkhede  <http://orcid.org/0000-0002-9277-3005>

Vidyadhar V. Gedam  <http://orcid.org/0000-0002-8083-1263>

References

- Agostini, L., and A. Nosella. 2020. "The Adoption of Industry 4.0 Technologies in Smes : Results of an International Study." *Management Decision* 58 (4): 625–643. doi:10.1108/MD-09-2018-0973.
- Ahmad, S., S. Miskon, R. Alabdan, and I. Tlili. 2020. "Towards Sustainable Textile and Apparel Industry: Exploring the Role of Business Intelligence Systems in the Era of Industry 4.0." *Sustainability* 12 (7): 2632. <https://doi.org/10.3390/su12072632>.
- Bag, S., A. Telukdarie, J. H. C. Pretorius, and S. Gupta. 2018. "Industry 4.0 and Supply Chain Sustainability: Framework

- and Future Research Directions." *Benchmarking: An International Journal* 1463–5771. doi:10.1108/BIJ-03-2018-0056.
- Bai, C., P. Dallasega, G. Orzes, and J. Sarkis. 2020. "Industry 4.0 Technologies Assessment: A Sustainability Perspective." *International Journal of Production Economics* 229: 107776. Elsevier B.V. doi:10.1016/j.ijpe.2020.107776.
- Beier, G., A. Ullrich, S. Niehoff, M. Reißig, and M. Habich. 2020. "Industry 4.0: How It is Defined from a Sociotechnical Perspective and How Much Sustainability It Includes – a Literature Review." *Journal of Cleaner Production* 259: 120856. doi:10.1016/j.jclepro.2020.120856.
- Belinski, R., A. M. M. Peixe, G. F. Frederico, and J. Arturo Garza-Reyes. 2020. "Organizational Learning and Industry 4.0: Findings from a Systematic Literature Review and Research Agenda." *Benchmarking: An International Journal* 27 (8): 2435–2457. doi:10.1108/BIJ-04-2020-0158.
- Benešová, A., J. Basl, J. Tupa, and F. Steiner. 2021. "Design of a Business Readiness Model to Realise a Green Industry 4.0 Company." *International Journal of Computer Integrated Manufacturing* 34 (9): 920–932. Taylor & Francis. doi:10.1080/0951192X.2021.1946858.
- Birkel, H. S., J. W. Veile, J. M. Müller, E. Hartmann, and K. Ingo Voigt. 2019. "Development of a Risk Framework for Industry 4.0 in the Context of Sustainability for Established Manufacturers." *Sustainability (Switzerland)* 11 (2): 1–27. doi:10.3390/su11020384.
- Carroll, A. B., and K. M. Shabana. 2010. "The Business Case for Corporate Social Responsibility: A Review of Concepts, Research and Practice." *International Journal of Management Reviews* 12 (1): 85–105.
- Cerezo-Narv, A., D. Garc, M. Otero-Mateo, and P. Ballesteros-P. 2019. "Standardizing Innovation Management : An Opportunity for Smes in the Aerospace Industry." *Processes* 7 (282): 1–42.
- Chen, J., L. Liu, and Y. Wang. 2021. "Business Model Innovation and Growth of Manufacturing Smes: A Social Exchange Perspective." *Journal of Manufacturing Technology Management* 32 (2): 290–312. doi:10.1108/JMTM-03-2020-0089.
- Chofreh, A. G., F. Ariani Goni, J. Jaromír Klemes, M. Noman Malik, and H. Hayat Khan. 2020. "Development of Guidelines for the Implementation of Sustainable Enterprise Resource Planning Systems." *Journal of Cleaner Production* 244. doi:10.1016/j.jclepro.2019.118655.
- Choudhary, S., R. Nayak, M. Dora, N. Mishra, and A. Ghadge. 2019. "An Integrated Lean and Green Approach for Improving Sustainability Performance: A Case Study of a Packaging Manufacturing SME in the U.K." *Production Planning and Control* 30 (5–6): 353–368. Taylor & Francis. doi:10.1080/09537287.2018.1501811.
- Da Silva, V. L., J. L. Kovalski, R. N. Pagani, J. D. M. Silva, and A. Corsi. 2020. "Implementation of Industry 4.0 Concept in Companies: Empirical Evidences." *International Journal of Computer Integrated Manufacturing* 33 (4): 325–342. Taylor & Francis. doi:10.1080/0951192X.2019.1699258.
- Das, M., and K. Rangarajan. 2019. "Impact of Policy Initiatives and Collaborative Synergy on Sustainability and Business Growth of Indian Smes." *Indian Growth and Development Review* 1753–8254. doi:10.1108/IGDR-09-2019-0095.
- Dassisti, M., A. Giovannini, P. Merla, M. Chimienti, and H. Panetto. 2018. "An Approach to Support Industry 4.0 Adoption in Smes Using a Core-Metamodel." *Annual Reviews in Control*. Elsevier Ltd: 1–9. doi:10.1016/j.arcontrol.2018.11.001.
- Demirel, P., and E. Kesidou. 2019. "Sustainability-Oriented Capabilities for Eco-Innovation: Meeting the Regulatory, Technology, and Market Demands." *Business Strategy and the Environment* 28 (5): 847–857. doi:10.1002/bse.2286.
- De Steur, H., X. Gellynck, and M. Canavari. 2019. "Drivers, Adoption, and Evaluation of Sustainability Practices in Italian Wine Smes." *Business Strategy and the Environment* 1–19. doi:10.1002/bse.2436.
- Dey, P. K., C. Malesios, D. De, P. Budhwar, S. Chowdhury, and W. Cheffi. 2020. "Circular Economy to Enhance Sustainability of Small and Medium-Sized Enterprises." *Business Strategy and the Environment* 1–25. doi:10.1002/bse.2492.
- Dutta, G., R. Kumar, R. Sindhwani, and R. Kumar Singh. 2020. "Digital Transformation Priorities of India's Discrete Manufacturing Smes – a Conceptual Study in Perspective of Industry 4.0." *Competitiveness Review* 30 (3): 289–314.
- Eggers, F. 2020. "Masters of Disasters? Challenges and Opportunities for SMEs in Times of Crisis." *Journal of Business Research* 116: 199–208 <https://doi.org/10.1016/j.jbusres.2020.05.025>.
- Eikelenboom, M., and G. de Jong. 2019. "The Impact of Dynamic Capabilities on the Sustainability Performance of Smes." *Journal of Cleaner Production* 235: 1360–1370. Elsevier Ltd. doi:10.1016/j.jclepro.2019.07.013.
- El Baz, J., S. Tiwari, T. Akenroye, A. Cherrafi, and R. Derrouiche. 2022. "A Framework of Sustainability Drivers and Externalities for Industry 4.0 Technologies Using the Best-Worst Method." *Journal of Cleaner Production* 344: 130909. doi:https://doi.org/10.1016/j.jclepro.2022.130909.
- Fonseca, L. M. 2015. "Strategic Drivers for Implementing Sustainability Programs in Portuguese Organizations—let's Listen to Aristotle: From Triple to Quadruple Bottom Line." *Sustainability: The Journal of Record* 8 (3): 136–142. doi:10.1089/SUS.2015.29004.
- Fonseca, L., A. Amaral, and J. Oliveira. 2021. "Quality 4.0: The EFQM 2020 Model and Industry 4.0 Relationships and Implications." *Sustainability* 13 (6): 3107. doi:10.3390/su13063107.
- Freeman, R. E. 2010. *Strategic Management: A Stakeholder Approach*. New York: Cambridge university press.
- Freeman, R. E., and S. Dmytriyev. 2017. "Corporate Social Responsibility and Stakeholder Theory: Learning from Each Other." *Symphonya* 1: 7–15.
- Frynas, J. G., and C. Yamahaki. 2016. "Corporate Social Responsibility: Review and Roadmap of Theoretical Perspectives." *Business Ethics: A European Review* 25 (3): 258–285. doi:10.1111/beer.12115.

- Ghobakhloo, M. 2019. "Industry 4.0, Digitization, and Opportunities for Sustainability." *Journal of Cleaner Production*. Elsevier B.V. doi:10.1016/j.jclepro.2019.119869.
- Ghobakhloo, M., and M. Fathi. 2020. "Corporate Survival in Industry 4.0 Era: The Enabling Role of Lean-Digitized Manufacturing." *Journal of Manufacturing Technology Management* 31 (1): 1–30.
- Ghobakhloo, M., and M. Iranmanesh. 2021. "Digital Transformation Success Under Industry 4.0: A Strategic Guideline for Manufacturing Smes." *Journal of Manufacturing Technology Management* 32 (8): 1533–1556. doi:10.1108/JMTM-11-2020-0455.
- Gilchrist, A. 2016. *Industry 4.0: The Industrial Internet of Things*. Heidelberg: Springer.
- Gu, F., J. Guo, P. Hall, and X. Gu. 2019. "An Integrated Architecture for Implementing Extended Producer Responsibility in the Context of Industry 4.0." *International Journal of Production Research* 57 (5): 1458–1477. <https://doi.org/10.1080/00207543.2018.1489161>.
- Hsu, C. H., A. Yuan Chang, and W. Luo. 2017. "Identifying Key Performance Factors for Sustainability Development of Smes – Integrating QFD and Fuzzy MADM Methods." *Journal of Cleaner Production* 161: 629–645. Elsevier Ltd. doi:10.1016/j.jclepro.2017.05.063.
- Ingaldi, M., and R. Ulewicz. 2020. "Problems with the Implementation of Industry 4.0 in Enterprises from the SME Sector." *Sustainability* 12 (1). doi:10.3390/SU12010217.
- Ivascu, L. 2020. "Measuring the Implications of Sustainable Manufacturing in the Context of Industry 4.0." *Processes* 8 (5): 585. <https://doi.org/10.3390/pr8050585>.
- Jabbour, C. J. C., P. D. C. Fiorini, N. O. Ndubisi, M. M. Queiroz, and É. L. Piato. 2020. "Digitally-Enabled Sustainable Supply Chains in the 21st Century: A Review and a Research Agenda." *The Science of the Total Environment* 725: 138177. <https://doi.org/10.1016/j.scitotenv.2020.138177>
- Jayashree, S., M. N. H. Reza, C. A. N. Malarvizhi, A. Gunasekaran, and M. A. Rauf. 2022. "Testing an Adoption Model for Industry 4.0 and Sustainability: A Malaysian Scenario." *Sustainable Production and Consumption* 31: 313–330. doi:10.1016/j.spc.2022.02.015.
- Jena, M. C., S. K. Mishra, and H. S. Moharana. 2020. "Application of Industry 4.0 to Enhance Sustainable Manufacturing." *Environmental Progress & Sustainable Energy* 39 (1): 13360. doi:10.1002/ep.13360.
- Kajol, S. Z., and Z. Shankar. 2021. "India's MSME Sector Largest After China's. But No One is Talking About Its Role in Emissions." <https://theprint.in/opinion/indias-msme-sector-largest-after-chinas-but-no-one-is-talking-about-its-role-in-emissions/745629/>.
- Kalmykova, Y., M. Sadagopan, and L. Rosado. 2018. "Circular Economy—from Review of Theories and Practices to Development of Implementation Tools." *Resour. Conserv. Recycl* 135: 190–201. <https://doi.org/10.1016/j.resconrec.2017.10.034>.
- Karuppiah, K., B. Sankaranarayanan, S. Mithun Ali, and P. Chowdhury. 2020. "An Integrated Approach to Modeling the Barriers in Implementing Green Manufacturing Practices in Smes." *Journal of Cleaner Production* 265: 121737. doi:10.1016/j.jclepro.2020.121737.
- Kirchherr, J., L. Piscicelli, R. Bour, A. Huibrechtse-Truijens, M. Hekkert, E. Kostense-Smit, and J. Muller. 2018. "Barriers to the Circular Economy: Evidence from the European Union (EU)." *Ecological Economics* 150: 264–272. <https://doi.org/10.1016/j.ecolecon.2018.04.028>
- Klewitz, J., and E. G. Hansen. 2014. "Sustainability-Oriented Innovation of Smes: A Systematic Review." *Journal of Cleaner Production* 65: 57–75. Elsevier Ltd. doi:10.1016/j.jclepro.2013.07.017.
- Kumar, S., R. D. Raut, V. S. Narwane, B. E. Narkhede, and K. Muduli. 2021a. "Implementation Barriers of Smart Technology in Indian Sustainable Warehouse by Using a Delphi-ISM-ANP Approach." *International Journal of Productivity and Performance Management*. doi:10.1108/IJPPM-10-2020-0511.
- Kumar, S., R. D. Raut, K. Nayal, S. Kraus, V. Surendra Yadav, and B. E. Narkhede. 2021b. "To Identify Industry 4.0 and Circular Economy Adoption Barriers in the Agriculture Supply Chain by Using ISM-ANP." *Journal of Cleaner Production* 293: 126023. doi:10.1016/j.jclepro.2021.126023.
- Kumar, S., R. D. Raut, M. M. Queiroz, and B. E. Narkhede. 2021c. "Mapping the Barriers of AI Implementations in the Public Distribution System: The Indian Experience." *Technology in Society* 67: 101737. Elsevier Ltd. doi:10.1016/j.techsoc.2021.101737.
- Lawrence, S. R., E. Collins, K. Pavlovich, and M. Arunachalam. 2006. "Sustainability Practices of Smes: The Case of NZ." *Business Strategy and the Environment* 15 (4): 242–257. doi:10.1002/bse.533.
- Leng, J., G. Ruan, P. Jiang, K. Xu, Q. Liu, X. Zhou, and C. Liu. 2020. "Blockchain-Empowered Sustainable Manufacturing and Product Lifecycle Management in Industry 4.0: A Survey." *Renewable and Sustainable Energy Reviews* 132: 110112. Elsevier Ltd. doi:10.1016/j.rser.2020.110112.
- Leong, W. D., S. Yong Teng, B. Shen How, S. Lin Ngan, A. Abd Rahman, S. G. P. Chee Pin Tan, and H. Loong Lam. 2020. "Enhancing the Adaptability: Lean and Green Strategy Towards the Industry Revolution 4.0." *Journal of Cleaner Production* 273: 122870. Elsevier Ltd. doi:10.1016/j.jclepro.2020.122870.
- Li, D., Å. Fast-Berglund, and D. Paulin. 2019. "Current and Future Industry 4.0 Capabilities for Information and Knowledge Sharing Case of Two Swedish Smes." *International Journal of Advanced Manufacturing Technology* 105 (9): 3951–3963. doi:10.1007/s00170-019-03942-5.
- Li, J., A. Maiti, M. Springer, and T. Gray. 2020. "Blockchain for Supply Chain Quality Management: Challenges and Opportunities in Context of Open Manufacturing and Industrial Internet of Things." *International Journal of Computer Integrated Manufacturing* 33 (12): 1321–1355. Taylor & Francis. doi:10.1080/0951192X.2020.1815853.
- Linder, C. 2019. "Customer Orientation and Operations: The Role of Manufacturing Capabilities in Small-And Medium-Sized Enterprises." *International Journal of*

- Production Economics* 216: 105–117. doi:10.1016/j.ijpe.2019.04.030.
- Lins, T. S., R. Augusto, and R. Oliveira. 2019. "Cyber-Physical Production Systems Retrofitting in Context of Industry 4.0." *Computers & Industrial Engineering* 139: 106193. <https://doi.org/10.1016/j.cie.2019.106193>.
- Luthra, S., A. Kumar, E. Kazimieras Zavadskas, S. Kumar Mangla, and J. Arturo Garza-Reyes. 2020. "Industry 4.0 as an Enabler of Sustainability Diffusion in Supply Chain: An Analysis of Influential Strength of Drivers in an Emerging Economy." *International Journal of Production Research* 58 (5): 1505–1521. Taylor & Francis. doi:10.1080/00207543.2019.1660828.
- Machado, C. G., M. Peter Winroth, and E. H. D. Ribeiro da Silva. 2020. "Sustainable Manufacturing in Industry 4.0: An Emerging Research Agenda." *International Journal of Production Research* 58 (5): 1462–1484. doi:10.1080/00207543.2019.1652777.
- Manupati, V. K., T. Schoenherr, M. Ramkumar, S. M. Wagner, S. K. Pabba, and R. I. R. Singh. 2020. "A Blockchain-Based Approach for a Multi-Echelon Sustainable Supply Chain." *International Journal of Production Research* 58 (7): 2222–2241. doi:10.1080/00207543.2019.1683248.
- Masood, T., and P. Sonntag. 2020. "Computers in Industry 4.0: Adoption Challenges and Benefits for Smes." *Computers in Industry* 121: 103261. Elsevier B.V. doi:10.1016/j.compind.2020.103261.
- Masurel, E. 2007. "Why Smes Invest in Environmental Measures: Sustainability Evidence from Small and Medium-Sized Printing Firms." *Business Strategy and the Environment* 16 (3): 190–201. doi:10.1002/bse.478.
- McWilliams, A., and D. S. Siegel. 2011. "Creating and Capturing Value: Strategic Corporate Social Responsibility, Resource-Based Theory, and Sustainable Competitive Advantage." *Journal of Management* 37 (5): 1480–1495. doi:10.1177/0149206310385696.
- Mittal, S., M. Ahmad, D. Romero, and T. Wuest. 2018. "A Critical Review of Smart Manufacturing & Industry 4.0 Maturity Models: Implications for Small and Medium-Sized Enterprises (SMEs)." *Journal of Manufacturing Systems* 49: 194–214. Elsevier. doi:10.1016/j.jmsy.2018.10.005.
- Moeuf, A., S. Lamouri, R. Pellerin, S. Tamayo-Giraldo, E. Tobon-Valencia, R. Eburdy, A. Moeuf, S. Lamouri, R. Pellerin, and S. Tamayo-Giraldo. 2020. "Identification of Critical Success Factors, Risks and Opportunities of Industry 4.0 in Smes." *International Journal of Production Research* 58 (5): 1384–1400. Taylor & Francis. doi:10.1080/00207543.2019.1636323.
- Müller, J. M., O. Buliga, and K. Ingo Voigt. 2018. "Fortune Favors the Prepared: How Smes Approach Business Model Innovations in Industry 4.0." *Technological Forecasting and Social Change* no. September 2017: 0–1. Elsevier. doi:10.1016/j.techfore.2017.12.019
- Müller, J. M., D. Kiel, and K. Ingo Voigt. 2018. "What Drives the Implementation of Industry 4.0? The Role of Opportunities and Challenges in the Context of Sustainability." *Sustainability (Switzerland)* 10 (1). doi:10.3390/su10010247.
- Munsamy, M., A. Telukdarie, and J. Fresner. 2019. "Business Process Centric Energy Modelling." *Business Process Management Journal* 25 (7): 1867–1890. doi:10.1108/BPMJ-08-2018-0217.
- Nam, T. 2019. "Technology Usage, Expected Job Sustainability, and Perceived Job Insecurity." *Technological Forecasting and Social Change* 138: 155–165. Elsevier.
- Naughton, S., I. Golgeci, and A. Arslan. 2020. "Supply Chain Agility as an Acclimatisation Process to Environmental Uncertainty and Organisational Vulnerabilities: Insights from British Smes." *Production Planning and Control* 31 (14): 1164–1177. Taylor & Francis. doi:10.1080/09537287.2019.1701130.
- Nimawat, D., and B. D. Gidwani. 2021. "Prioritization of Barriers for Industry 4.0 Adoption in the Context of Indian Manufacturing Industries Using AHP and ANP Analysis." *International Journal of Computer Integrated Manufacturing*. Taylor & Francis: 1–23. doi:10.1080/0951192X.2021.1963481.
- Nwaiwu, F., M. Duduci, F. Chromjakova, and C.-A. Funke Otekhile. 2020. "Industry 4.0 Concepts Within the Czech SME Manufacturing Sector: An Empirical Assessment of Critical Success Factors." *Business: Theory and Practice* 21 (1): 58–70.
- Pham, T. T., T. Chi Kuo, M. Lang Tseng, R. R. Tan, K. Tan, D. Satria Ika, and C. Joe Lin. 2019. "Industry 4.0 to Accelerate the Circular Economy: A Case Study of Electric Scooter Sharing." *Sustainability* 11 (23): 1–16. doi:10.3390/su11236661.
- Prause, M. 2019. "Challenges of Industry 4.0 Technology Adoption for Smes: The Case of Japan." *Sustainability* 11 (5807): 1–13.
- Rahman, T., S. Mithun Ali, M. Abdul Moktadir, and S. Kusi-Sarpong. 2020. "Evaluating Barriers to Implementing Green Supply Chain Management: An Example from an Emerging Economy." *Production Planning and Control* 31 (8): 673–698. Taylor & Francis. doi:10.1080/09537287.2019.1674939.
- Raj, A., G. Dwivedi, A. Sharma, A. B. L. de Sousa Jabbour, and S. Rajak. 2020. "Barriers to the Adoption of Industry 4.0 Technologies in the Manufacturing Sector: An Inter-Country Comparative Perspective." *International Journal of Production Economics* 224: 107546. Elsevier B.V. doi:10.1016/j.ijpe.2019.107546.
- Rajput, S., and S. P. Singh. 2021. "Industry 4.0 – Challenges to Implement Circular Economy". *Benchmarking: An International Journal* 28 (5): 1717–1739.
- Ramanathan, U., E. Mazzola, U. Mohan, M. Bruccoleri, A. Awasthi, and J. Arturo Garza-Reyes. 2020. "How Selection of Collaborating Partners Impact on the Green Performance of Global Businesses? An Empirical Study of Green Sustainability." *Production Planning and Control*. Taylor & Francis: 1–16. doi:10.1080/09537287.2020.1796133.
- Rossit, D. A., F. Tohmé, and M. Frutos. 2019. "Industry 4.0: Smart Scheduling." *International Journal of Production Research* 57 (12): 3802–3813. doi:10.1080/00207543.2018.1504248.
- Saad, S. M., R. Bahadori, and H. Jafarnejad. 2021. "The Smart SME Technology Readiness Assessment Methodology in the Context of Industry 4.0." *Journal of Manufacturing Technology Management*. 32 (5): 1037–1065. ahead-of-p (ahead-of-print). doi:10.1108/jmtm-07-2020-0267.

- Salimzadeh, P., and J. Courvisanos. 2015. "A Conceptual Framework for Assessing Sustainable Development in Regional Smes." *Journal of Environmental Assessment Policy and Management* 17 (4): 1–17. doi:10.1142/S1464333215500398.
- Sanchez, M., E. Exposito, and J. Aguilar. 2020. "Industry 4.0: Survey from a System Integration Perspective." *International Journal of Computer Integrated Manufacturing* 33 (10–11): 1017–1041. Taylor & Francis. doi:10.1080/0951192X.2020.1775295.
- Saqib, Z. A., and Q. Zhang. 2021. "Impact of Sustainable Practices on Sustainable Performance: The Moderating Role of Supply Chain Visibility." *Journal of Manufacturing Technology Management* 32 (7): 1421–1443. doi:10.1108/JMTM-10-2020-0403.
- Sevinç, A., S. Gür, and T. Eren. 2018. "Analysis of the Difficulties of Smes in Industry 4.0 Applications by Analytical Hierarchy Process and Analytical Network Process ,." *Porcesses* 6 (264): 1–16. doi:10.3390/pr6120264.
- Shibin, K. T., R. Dubey, A. Gunasekaran, Z. Luo, T. Papadopoulos, and D. Roubaud. 2018. "Frugal Innovation for Supply Chain Sustainability in Smes: Multi-Method Research Design." *Production Planning and Control* 29 (11): 908–927. Taylor & Francis. doi:10.1080/09537287.2018.1493139.
- Siegel, R., J. Antony, J. Arturo Garza-Reyes, A. Cherrafi, and B. Lameijer. 2019. "Integrated Green Lean Approach and Sustainability for Smes: From Literature Review to a Conceptual Framework." *Journal of Cleaner Production* 240. doi:10.1016/j.jclepro.2019.118205.
- Singh, R. K., S. Luthra, S. Kumar, and S. Uniyal. 2019. "Resources, Conservation & Recycling Applications of Information and Communication Technology for Sustainable Growth of Smes in India Food Industry." *Resources, Conservation & Recycling* 147 (January): 10–18. Elsevier. doi:10.1016/j.resconrec.2019.04.014.
- Tiwari, P., P. V. Ilavarasan, and S. Punia. 2019. "Content Analysis of Literature on Big Data in Smart Cities." *Benchmarking* 28 (5): 1837–1857. <https://doi.org/10.1108/BIJ-12-2018-0442>.
- Tiwari, K., and M. S. Khan. 2020. "Sustainability Accounting and Reporting in the Industry 4.0." *Journal of Cleaner Production* 258: 120783. <https://doi.org/10.1016/j.jclepro.2020.120783>
- Ubaid, A. M., F. T. Dweiri, and U. Ojiako. 2020. "Organizational Excellence Methodologies (OEMs): A Systematic Literature Review." *International Journal of Systems Assurance Engineering and Management*. 11 (6): 1395–1432. Springer India. doi:10.1007/s13198-020-01017-3.
- Warfield, J. N. 1974. "Developing Subsystem Matrices in Structural Modeling." *IEEE Transactions on Systems, Man, and Cybernetics* 4 (1): 51–81.
- Wijethilake, C., and B. Upadhaya. 2020. "Market Drivers of Sustainability and Sustainability Learning Capabilities: The Moderating Role of Sustainability Control Systems." *Business Strategy and the Environment*, no. August 2019: 1–13. doi:10.1002/bse.2503.
- The World Bank. 2020. "Small and Medium Enterprises (SMES) Finance." <https://www.worldbank.org/en/topic/smefinance> .
- Yadav, G., A. Kumar, S. Luthra, J. Arturo Garza-Reyes, V. Kumar, and L. Batista. 2020. "A Framework to Achieve Sustainability in Manufacturing Organisations of Developing Economies Using Industry 4.0 Technologies' Enablers." *Computers in Industry* 122: 103280. Elsevier B.V. doi:10.1016/j.compind.2020.103280.
- Yin, Y., K. E. Stecke, and D. Li. 2018. "The Evolution of Production Systems from Industry 2.0 Through Industry 4.0." *International Journal of Production Research* 56 (1–2): 848–861. doi:10.1080/00207543.2017.1403664.
- Zambon, I., M. Cecchini, G. Egidi, M. Grazia Saporito, and A. Colantoni. 2019. "Development for Smes." *Processes* 7 (36): 1–16. doi:10.3390/pr7010036.

Barriers to adoption of industry 4.0 and sustainability: a case study with SMEs

Kumar, Shashank

2022-10-11

Attribution 4.0 International

Kumar S, Raut RD, Aktas E, et al., (2023) Barriers to adoption of industry 4.0 and sustainability: a case study with SMEs, *International Journal of Computer Integrated Manufacturing*, Volume 36, Issue 5, 2023, pp. 657-677

<https://doi.org/10.1080/0951192X.2022.2128217>

Downloaded from CERES Research Repository, Cranfield University