

**Forensic fractography of bone: fracture origins from  
impacts, and an improved understanding of the failure  
mechanism involved in beveling**

**Angi M. Christensen**

Federal Bureau of Investigation Laboratory

**John M. Rickman**

Cranfield Forensic Institute, Cranfield University,  
Defence Academy of the United Kingdom

**Hugh E. Berryman**

Middle Tennessee State University

## **Abstract**

Fractography involves the study of fractures and cracks in a material in order to understand the cause of failure. Even as a complex, highly hierarchical composite, bone is a material that obeys physical laws, including cracking behavior. The fields of fractography and fracture mechanics therefore have much to offer in our understanding of bone's response to loading and force. Here we discuss how fractography can be used in the assessment of fractures originating from impacts including those from projectiles. Fractures and fracture patterns frequently associated with impact trauma—including radial fractures, circumferential fractures, and beveling—are described and used interpretively in forensic analyses; however, the mechanisms for their production and arrangement are often underutilized in fully understanding the trauma event. These mechanisms are reviewed here from a fractography perspective. Furthermore, a review is presented of new data indicating that beveling in bone associated with impacts, especially with projectiles, is produced by cone cracking, a process that is also well documented in other brittle materials. This information can be used to enhance understanding of impact trauma in general, as well as in the context of specific forensic cases. Moreover, describing and interpreting skeletal trauma within the context of fracture mechanics and fractography has the advantage of aligning the nomenclature used in forensic anthropology with that used in other scientific fields, particularly those involved in the study of material failure. To facilitate this alignment, we provide discussion and definitions for various fractography-related terms.

**Key Words:** fractography, beveling, skeletal trauma, impacts, fracture mechanics, cone cracking

## *Introduction*

Skeletal trauma analysis is an important contribution of forensic anthropologists to the medicolegal system. Skeletal fracture patterns and features are often examined to assess trauma mechanism (for example, blunt, sharp, or projectile), as well as other aspects of the trauma event (such as timing, direction, and magnitude). Traditionally these analyses focused on the overall fracture pattern of the bone including fragment shape and intersection of fracture margins, often emphasizing categorization of fractures into types.

Forensic skeletal trauma analysis has experienced a recent shift from emphasizing typological and morphological description to interpretation based on bone's mechanical properties and its response to force (the action of one object on another) and different loading regimes (the way forces are applied to an object). It is also recognized that this shift should involve consideration of the nomenclature used in these analyses (e.g., Ubelaker 2019; L'Abbé et al. 2019). The fracture analysis principles and nomenclature used in skeletal trauma analyses should ideally be aligned with those used in the other sciences that study material failure (with many of these having been long established in other sciences prior to their application in forensic anthropology). For example, anthropologists (as well as pathologists and clinicians) typically refer to any discontinuity in bone as a "fracture." In fracture mechanics, "fracture" refers to the separation of an object or material into two or more pieces, while a "crack" refers to the plane of separation in a structure (so a crack might be a fracture in progress).

Fracture is a function of the application of enough stress (load per unit area) to cause a crack to propagate through a structure. If there is a crack in a structure but there is no stress acting on it, it will not fracture; if the stresses are large but the crack is very small, it may not propagate.

Fracture can result from a single event that creates and propagates a crack, or it may result from a series of events involving the introduction of a crack and then subsequent loading(s) that causes it to propagate. The fracture pattern and fracture surfaces contain clues to the intrinsic and extrinsic factors responsible for fracture morphology. The origins and propagation of cracks (whether or not the material fractures into multiple pieces) are of significant interest in the study of material failure.

The earliest papers presented by anthropologists that explored bone trauma appeared in the early 1990s at the American Academy of Forensic Sciences annual meetings (e.g., Berryman et al. 1990; 1991a; 1991b; Symes et al. 1991; Smith et al. 1991; 1992). While these papers were largely descriptive with a basic understanding of the biomechanics responsible, they were validated through observations made at autopsy where fracture patterns and the extrinsic factors that produced them were discoverable. Anthropologists developed terms (e.g., radiating fractures, concentric fractures, breakaway spurs, internal and external bevel, bone plugs, spall) as a necessity to describe these observations, but these terms often lacked a basis in materials science. This paper examines skeletal fractures within the context of failure analysis, including an assessment of the production of the bevel (defined as the angling of fracture propagation produced by an impact creating a defect that is larger on one surface of the structure than the other) associated with blunt impacts and impacts associated with projectiles (referring to an object projected by an external force, which may be at a low or high velocity). This discussion will also serve to facilitate the alignment of some of the terms typically used by forensic anthropologists to describe bone fracture patterns with terms already used by materials scientists.

### *Overview of Fractography*

Fractography refers to the study of fractures and cracks in a material in order to understand the cause of failure. Even as a complex, highly hierarchical composite, bone is a material that obeys the laws of physics and mechanics, including cracking behavior. The fields of fractography and fracture mechanics therefore have much to offer in our understanding of bone's response to loading and force.

The use of fractography to study bone is not new, with much work emphasizing the analysis of fracture surfaces (often using scanning electron microscopy), which can reveal significant information about bone biomechanical properties and failure. Fracture surface analysis can yield information about the mode by which the crack has propagated through the material (e.g., Hull 1999; Martens et al. 1986; Vashishth et al. 2000). Analysis of fracture surfaces of human tibiae subjected to bending revealed ductile failure mechanisms along the side subjected to tension (Kimura et al. 1977). Similarly, analysis of femoral fracture surfaces created by bending tests revealed fiber pull-out on the tensile surface but not on the compressive side (Braidotti et al. 1997). Fracture surfaces may also provide information about why failure occurred at the microstructural level (Corondon & Haworth 1986; Wise et al. 2007). Examination of fracture surface morphology in human long bones demonstrated that the fracture site contained fewer osteons, less percentage volume of osteons, and osteons with smaller cross-sectional area than bone adjacent to it (Corondon & Haworth 1986). Examination of the path of the crack through the microstructures of compact bone has also been demonstrated to reveal information about strain rate (the change in strain (change in dimension relative to initial length) of a material with respect to time). At low loading rates, cracks in compact bone follow a tortuous route along paths of least resistance such as osteonal interfaces; in contrast, at higher strain rates the crack shows no preference for such

weak interfaces and propagates through all microscopic components (Piekarksi 1970; Pope & Outwater 1972). This characteristic strain rate effect on fracture morphology has subsequently been shown to be of some use in differentiating blast trauma from lower strain rate traumatic events (Pechníková et al. 2015).

More recently, principles of fractography have been applied specifically to forensic anthropological questions. Several studies have demonstrated the utility of fractography for interpreting aspects of skeletal fractures including crack propagation direction. In an assessment of femora fractured experimentally in 3-point bending, anthropologists and fractographers analyzed the presence and orientation of fracture surface features and found them to be reliable indicators of fracture origin location and propagation direction, as well as finding very strong agreement between assessors (Christensen et al. 2018). In a review of an autopsy sample of blunt trauma cases, fractographic features were found to corroborate autopsy soft tissue and radiologic findings, as well as traditional forensic anthropological skeletal trauma analyses (Love & Christensen 2018). The added value of examining fracture surfaces and not merely relying on classification of 2-dimensional fragment shape has been recognized for the assessment and interpretation of the various failure modes involved in “butterfly” fractures (L’Abbé et al. 2019). A study of complex fractures found that fracture surface features support fracture propagation ground truth as documented through high-speed video (Isa et al. 2020). Most studies have focused on fractures resulting from blunt trauma, but some fracture surface features have also been noted in association with American Civil War projectile traumas (Lillard & Christensen In Press). It has also been shown that some fractographic features can be seen in traditional medical and postmortem CT scans (Christensen & Hatch 2019; Christensen & Decker 2020), suggesting that fractography may be applicable to a broader scope of contexts than dry bones. Projectile impact

fracture mechanisms have also been elucidated using high-speed video and micro-CT (Rickman & Shackel 2019a; 2019b); these mechanisms and others will be discussed in more detail in the following sections.

Despite the complex fracture patterns that can be observed in skeletal trauma, there are only three fracture modes underlying crack propagation (Figure 1). *Mode I* (opening) fracture designates a tensile stress acting normal (perpendicular) to the plane at the crack tip, as the two faces of material on either side of the crack are pulled apart. Mode I fracture is particularly significant to the study of bone fracture patterns because bone is weakest in tension. *Mode II* (shearing) fracture occurs due to in-plane shear, a stress acting parallel to the plane of the crack and perpendicular to the crack tip. Mode II loading influences crack growth direction. *Mode III* (tearing) fracture occurs due to out-of-plane shear, a stress acting parallel to the crack plane and parallel to the crack tip. It is important to note that while each of these fracture modes can be experimentally induced by applying the appropriate stresses, fracture *in vivo* is likely to result from mixed-mode loading due to such factors as bone shape and the orientation of the crack in relation to the applied load (Zimmerman et al. 2009).

[Fig. 1]

### *Fracture origins from impacts*

The failure modes operative during impact-related fracture are complex and depend upon a variety of intrinsic factors (target and impacting material characteristics including elastic properties, geometry, and density) and extrinsic factors (including projectile velocity, mass, striking-surface area and design) (Zukas 1982). Bone presents a particularly complex material for failure analyses

due to its hierarchical structure, in which failure can occur on multiple scales (Currey 2002). Despite this microstructural complexity, bone typically exhibits brittle, ceramic-type behavior (undergoing little plastic deformation and having low energy absorption before failure) at high strain rates (Smith et al. 1993). Many of the fractography principles involved in failure of ceramics and other brittle materials are therefore informative and relevant to impact failure in bone (see for example, Quinn 2016). Importantly to understanding impact-related failure, most fractures involve uniaxial or biaxial stress states (or stresses in either one or two dimensions). Impacts, however, involve a triaxial stress state, with stresses in all three directions (Figure 2).

[Fig. 2]

A fracture origin refers both to the location as well as the flaw or discontinuity from which a fracture began. The term “flaw” does not necessarily refer to something negative – it is recognized that brittle materials (including bone) are imperfect and contain irregularities and inhomogeneities that can represent the site where a fracture initiates. Fracture origins in manufactured materials may result from, for example, manufacturing defects, machining, corrosion, or wear. They may be on the interior of a structure or on the surface. They may consist of inclusions of another material type, irregularities within the same material, or voids in the material. They can result from temperature differentials or be produced by impacts with sharp, blunt, or fast-moving objects.

In forensic anthropological contexts, fracture origins are often created by sudden impacts (for example, with blunt objects, the ground, a bullet, or a blade). These impacts cause dynamic crack initiation and propagation. In skeletal trauma analyses, fracture origins are typically of interest in understanding the location where a bone was impacted (i.e., from where the force originated). Much work has therefore focused on the relationship between fracture patterns and impact

location, such as whether fracture origins are at the impact site or elsewhere (e.g., Gurdjian et al. 1947, 1950; Kroman et al. 2011; Isa et al. 2018; Isa et al. 2019; Powel et al. 2012). The relationship is somewhat complex, however, and the location of the fracture origin will depend on where the tensile stresses are greatest. Fracture origin is related to a number of factors in addition to impact location including loading regime, surface area of loading, elastic properties of the two impacting materials (e.g., the bone and the projectile), stress concentrators, and structure geometry.

Stress concentrators (a feature within a structure that results in greater stresses in its vicinity than are present in areas more remote from it) are important considerations because they may function as a crack origin in an area not otherwise expected based on overall material properties or geometry. Stress concentrators generally include voids/cavities, inclusions, compositional irregularities, and microdamage. If stress concentrators are located in the stress field created by an impactor, the crack will originate at that location. For example, a nutrient foramen opening in tubular bone creates a surface flaw that can act as a stress concentrator. Cracks have indeed been noted to originate at nutrient foramen openings in tests of impacted bone (Christensen et al. 2018, Rickman & Shackel 2019a) (Figure 3). Other foramina in bones and even openings in cranial sutures may also act as stress concentrators. Grain boundaries (the interfaces between two crystallites in a polycrystalline material) can be vulnerable areas in coarse grained materials, though boundaries and discontinuities in bone such as lamellar interfaces and cement lines between osteons and surrounding bone may also serve to arrest fracture advance (Piekarski 1970; Burr et al. 1988; Pope & Outwater 1972). Microdamage (diffuse damage and microcracks in bone caused by normal physiological loading) may also give rise to residual strains that could act as stress concentrators. Aging and disease can also significantly affect the mechanical properties of bone

and increase strength limiting features including increased porosity and the accumulation of microdamage, both of which can increase the potential for failure (Morgan et al. 2018).

[Fig. 3]

Cracks do not necessarily originate at the impact site and can initiate adjacent or even remote to the impact site. Lower forces or impacts from objects with large surface areas may not necessarily create cracking on the impacted side of a structure. Bending force can create tensile stresses on the opposite side and trigger crack growth at that location. For example, a blunt impact to the cranium will create tension on the endocranial surface, and cracks will originate endocranially. These fractures may not necessarily propagate all the way through to the ectocranial surface. For blunt objects impacting glass plates, the object can create bending forces such that the crack originates from a flaw (a stress concentrator) at the edge of the plate, with the crack running back to the impact site (Quinn 2016). Similar crack initiation and propagation has been observed in blunt cranial impacts (Gurdjian et al. 1947, 1950; Isa et al. 2019). In tubular bones, it is well understood that impacts can impose bending stresses (such as the bumper of a car impacting a tibia), creating tension on the side of the bone opposite the impact, which is where the crack will originate.

Identification of the fracture origin is often a relevant and informative part of the investigation into material failure. Fracture origins can be identified using a number of approaches and by examining several features of the fractured structure. In certain materials, fragment size and shape may be related to the fracture origin. For example, in fractured tempered glass, it is often possible to find the two fragments adjacent to the origin based on their larger size and distinctive morphology compared to the other fragments (Figure 4). Fracture origins can also be identified based on

features of the fracture surface (e.g., Christensen et al. 2018), with fracture origins typically having smoother surfaces, becoming more featured with increasing crack speed and instability. Other features related to fracture origins from impacts include fracture patterns, which are addressed in the following section.

[Fig. 4]

*Fracture patterns from impacts: radial, circumferential, and cone cracks*

Impacts can create localized damage at the impact site that may represent the origin of the fracture, including crushing, chips, patterned marks, impressions, and displaced fragments. The impact event may transfer intervening materials into the target material, or the target material may retain fragments of the impacting material. Impact sites may therefore be evidenced by inclusions of debris such as tissue, hair, metal fragments, or other materials. In addition to surface damage, impacts may produce microcracks that penetrate beneath the impact site. These cracks may occur in the absence of impact site damage, and their extent may not necessarily be correlated with surface damage.

At higher velocities, radial cracks (cracks extending outward from a point of impact, sometimes also called radiating fractures) may be generated from the impact site originating from within the zone of the contact and propagating outward. These tend to be easy to identify and interpret, as the cracks fan out away from the impact site such that the radiating crack pattern leads back to converge in the middle (Figure 5, left). In addition to being informative as to the impact location, radiating fractures in other brittle materials also have relationships to other intrinsic and extrinsic factors. In indentation testing, the sums of the lengths of cracks emanating from an impact are related to the extrinsic load and the intrinsic material toughness (Palmqvist 1957). Much more

research is needed to understand these implications for skeletal trauma analysis, but further investigation of radial cracks in bone from a fractography perspective may reveal that these cracks can provide more information about the trauma event than just the impact location.

[Fig. 5]

If the structure is continually loaded, the segments created by the radial fractures can bend inward, causing them to break in bending, leading to circumferential cracks (arc-shaped cracks surrounding an impact site as a result of bending of a structural segment) (Figure 5, right). These roughly circular, semi-circular, or arc-shaped fractures are often offset by the radial fractures confirming that the radial fractures preceded the secondary circumferential fractures. In lower velocity impacts, the maximum tension is on the impacted side of the material and the circumferential fracture therefore initiates ectocranially, propagating toward the endocranial surface. With high-velocity perforating impacts to crania (because the cranium is an enclosed structure), the segments produced by radial fractures may be pushed outward due to the temporary cavity created by energy transfer from the projectile, resulting in circumferential fractures that initiate on the endocranial surface. Note that the term *concentric* has traditionally been used interchangeably with *circumferential* by anthropologists and others to refer to this fracture pattern. Technically, *concentric* refers to multiple generations of arc-shaped fractures sharing a common center (rather than a single arc). In glass fractures, for example, *concentric* describes the nature of multiple arrest lines from cyclical loading or the arrangement of Wallner lines about the crack origin (Figure 6). Concentric fractures are less common but occasionally seen in high-velocity projectile impacts to bone (Figure 7).

[Fig. 6]

[Fig. 7]

When ceramics and glasses are indented or impacted by round or hemispherical projectiles, a common failure mechanism is a cone crack, which is a conoidal fracture resulting from an object impacting or passing through a brittle material), first described in the late nineteenth century by Hertz (1896) (and therefore sometimes referred to as Hertzian cone cracking). When the applied load reaches a critical value (dependent on the elastic properties of the two materials), a ring crack (the circular-shaped origin associated with a cone crack) originates in the zone of maximum tension located just outside of and concentric with the indenter contact radius (Figures 8 and 9) (Frank & Lawn 1967; Lawn 1998). For impact that does not involve penetration of the target by the projectile, there is a relationship between the size of the projectile and the ring crack, such that the impacting object is larger than the crack ring on the impacted surface (Quinn 2016).

[Fig. 8]

[Fig. 9]

As with many other fractures, a cone crack will propagate along paths that maximize strain energy release, typically normal to the greatest tensile stresses, with in-plane shear stress influencing crack growth direction. On the surface, the first principle stress is tensile, with a maximum value at the edge of the contact circle, and is responsible for the formation of the initial shallow ring. The initial ring crack propagates normal to the free surface of the structure for a very short distance. The ring depth is approximately uniform around the circumference, and at this point the stresses are axi-symmetric (Warren et al. 1995). With increasing load, the crack tip stress intensity factor (a value used in mechanics to predict the stress state near a crack tip caused by a remote load or residual stresses) around the ring crack increase until a critical value is reached, at which point the

crack will propagate outward for a distance that is related to the load (Lawn 1995, Warren et al. 1995). The angle of the cone crack depends on the material's Poisson's ratio (or the ratio of lateral and axial strain for a structure in uniaxial stress) as well as shear stresses, structure thickness, and method of support (Fischer-Cripps 2007). Propagation of a cone crack through the full thickness of a structure results in the formation of a conoid (cone shaped piece) of material (which may remain intact for lower impact velocities) and leaves behind a conoidal void. This conoid typically undergoes comminution (the breaking up of bone into smaller pieces) if the impact is ultimately a perforation event (Zaera et al. 1998; Kaufmann et al. 2003).

Cone cracking is well understood to be the mechanism responsible for bevel production in other brittle materials such as glass, for example when a bullet passes through a window (Figure 10). Projectile impacts to bone result in a fracture pattern that bears a striking resemblance to cone cracking in ceramics and glasses. This pattern consists of a circular fracture with an associated conoidal bevel flaring in the direction of projectile travel (Berryman et al. 1998) (Figure 11). However, despite the considerable morphological similarity between beveled fractures in bones and those seen in other brittle materials subsequent to cone cracking, few of the hypotheses proposed for the formation of beveling in bone considered cone cracking as a mechanism. Such hypotheses have included lack of support of the inner table (Shattock 1923), bevel formation through bending and associated compressive/tensile failure under the projectile (Rhine & Curran 1990), bevel production due to projectile deformation and enlargement during perforation (Byers 2002), bevel formation due to shear forces angling fractures toward fixed bone ends (Berryman et al. 2018; Berryman 2019), and perhaps the most widely cited, bevel formation by plug-and-spall (Peterson 1991, Komar & Buikstra 2008; Symes et al. 2012; Kimmerle & Baraybar 2008; Kieser

et al. 2011). Note that in impact dynamics, “spall” refers to a wave-induced fracture phenomenon, while in anthropology the term “spall” is typically used to refer to fragmentation.

[Fig. 10]

[Fig. 11]

Many of these hypotheses may be reasonably challenged on both mechanistic and, based on new experimental evidence, fractographic grounds. Recent experimental observation of bevel formation using high speed videography found no evidence of a shear plug on the exiting side of the bone (Rickman & Shackel 2019a). The plug-and-spall hypothesis suggests that a cortical shear plug creates the bevel by either shearing through the trabeculae (Kimmerle and Baraybar 2008) or through the accumulation of material ahead of it (Kieser et al 2011). However, cross-sectional analysis of projectile fractures in non-human flat bones using micro-computerized tomography ( $\mu$ CT) has revealed that the fracture edge of the bevel is present behind fragments of bone attached to the inner cortical plate (Figure 12), which precludes bevel formation via impact with a plug or accumulated material (Rickman & Shackel 2019a). In an experimental series, low velocity (<100 m/s or 328 f/s; note, a Daisy Red Ryder BB gun has a muzzle velocity of 350 f/s) impacts were utilized to capture the fracture processes operative during projectile impact and demonstrated that the bevel is created in the absence of projectile exit (Rickman & Shackel 2019b), ruling out projectile deformation and cortical shear plugging in bevel formation. Moreover, when documented plugs have been recovered subsequent to impact, they have consisted of all three layers of the flat bone and fit into the bevel with a part-counterpart relationship (Murphy et al. 2010, Murphy et al. 2014, Bird & Fleishman 2015).

[Fig. 12]

In an alternative hypothesis for bevel production, conoidal fractures in sandwich bones are proposed to be produced through a process of cone cracking (Rickman & Shackel 2019a). (In mechanics, “sandwich-structured composites” are those with stiff faces separated by a lightweight core; some bones including cranial bones and scapulae are configured this way, with two layers of cortical bone separated by diploë. This is an efficient way to resist mechanical loads with the least amount of material possible, because this configuration has a large moment of inertia and high bending stiffness for the material’s weight). In cone cracking of sandwich bone, a cone crack initiates at the moment of impact in the outer cortical layer and propagates through the trabeculae one cell at a time to the inner cortical layer. Fractographic evidence for this includes angulated cortical fracture edges at the cortical entry and trans-laminar crack propagation across the trabecular and inner cortical bone (Figure 13). At high velocity, this mechanism results in the momentary formation of a conoid of bone consisting of all three flat bone layers that immediately fragments to form the bony ejecta, although fragments of the cortical floor of the conoid may remain intact and attached to the margin of the bevel.

[Fig. 13]

Of the previously presented hypotheses, cone cracking is most closely approximated by bevel formation due to shear forces angling fractures toward fixed or cantilevered bone ends (Berryman et al. 2018; Berryman 2019) (Figure 14), which is essentially occurring in a circular fashion. The area of bone around an impact such as a gunshot entrance is cantilevered or fixed. The ring crack opens initially under tension, then propagates outward by shear at the crack tip. This mechanics of bevel formation also explain why circumferential fractures resulting from low-velocity impacts that initiate on the ectocranial surface will be beveled internally, while those from high-velocity projectiles that initiate on the endocranial surface will be beveled externally (Berryman et al. 2018;

Berryman 2019; Hart 2005). In impacts from high-velocity bullets, rifling in the gun barrel imparts a spin to the bullet giving it gyroscopic stability in flight and greatly increasing accuracy. Upon contact with bone, this spin may transmit additional stresses that may influence cone dimension and morphology. The geometry of the impacted bone on the impact side may also reflect characteristics of the projectile (Smith et al. 1991).

[Fig. 14]

Work utilizing low-velocity impacts has successfully captured the formation of both ring and cone cracks in the outer cortical layer (Rickman & Shackel 2019b) and produced intact and fragmentary bone conoids (Rickman & Shackel 2019b). An almost fully intact conoid produced by this experimental work is shown in Figure 12. Significantly, the morphology of this conoid is identical to those recovered in human bone (Murphy et al. 2010; Murphy et al. 2014; Bird & Fleishman 2015) as well as in other brittle materials.

Cone cracking underlies bevel production from low through to high velocity, which explains why beveled fractures can be produced as a result of blunt and low velocity projectile impact (e.g., see Vermeij et al. 2012; Spatola 2015; Quatrehomme et al. 2015). Furthermore, this raises the important questions of what information can, and cannot, be accurately derived from blunt trauma impact sites or projectile entrance/exit sites. In synthetic brittle materials, cone crack angle (measured as the half-angle of the cone) is known to decrease with increasing impact velocity (Knight et al. 1977; Chaudhri 2015), resulting in less flared cones at higher velocity. This relationship has been successfully utilized in glass to estimate projectile impact velocity from the cone angle (Myamoto & Murakami 2000). Cone crack angle is also known to vary with specimen thickness (Myamoto & Murakami 2000) and angle of impact (Chaudhri 2015). Preliminary work

on the angle of the entry cortical fracture edge has revealed considerable variation between specimens and even within specimens around the circumference of the cortical entry (Rickman & Shackel 2019a). Further experimental work is needed on the angle of beveled fractures in bone to establish the intrinsic and extrinsic factors that influence bevel geometry.

Bevel geometry is also of significance in forensic anthropology due to its use as a trajectory indicator. While areas of asymmetric beveling in relation to the central axis are considered to reveal projectile trajectory (Rhine & Curran 1990; Spitz 2006), experimental data has found a poor correlation between these variables (Quatrehomme & İşcan 1998). Asymmetric beveling has also been found to be more common than symmetric beveling (Quatrehomme & İşcan 1998), even in association with perpendicular impact (Rickman & Shackel 2019a; Rickman & Shackel 2019b). The fact that the bevel is formed at the moment of impact rather than during projectile exit means that bevel symmetry must be determined by the initial angle of the cone crack and the subsequent path it takes through the bone (Rickman & Shackel 2018), as well as intrinsic factors such as bone geometry. Accordingly, although trajectory is likely to play some part in determining cone crack geometry, caution should be applied when using this feature to determine the path taken by the projectile when an associated exit fracture is not available.

### *Discussion and Conclusion*

The fields of fractography and fracture mechanics can significantly inform our understanding of bone's response to loading and force. This is becoming more widely embraced by forensic anthropologists, and the application of the science of fractography to the study and analysis of skeletal fractures in forensic contexts represents part of the shift from a typological to a mechanics-

centered approach. As a relatively new method in forensic anthropology, fractography is not yet widely known or understood, and is not commonly taught as part of forensic anthropological educational or training programs. Fractography is also heavily based in engineering principles, and it is recognized that most forensic anthropologists do not possess engineering backgrounds. Here we have attempted to provide readers with an overall better understanding of the formation of fractures related to impacts to bone from a fractography perspective, particularly the formation of cone cracks. Importantly, failure and fracture patterns are strongly influenced by structure geometry, and within the human skeleton there is significant variation in bone shape and configuration. Therefore, the response of each bone or bone type to certain loading conditions will vary. Cone cracks, however, have also been documented in long bones (Kieser et al. 2014) so they are not limited to bones with sandwich structures. Additional research on different loading and impacting regimes may clarify the creation and appearance of cone cracks and other fracture patterns on various bone types.

In addition to improved understanding of the formation of cone cracks in bone, the assessment of beveling and other cracking patterns in terms of fracture mechanics also has the appeal of aligning anthropology with the fractography and materials science community under similar terminologies. These well-established fields have much to offer in our understanding of bone failure, but we should ensure that principles are faithfully employed and the terminology is appropriately adopted in order to avoid rendering terms meaningless or confusing by their loose application. To facilitate this alignment, we have discussed and defined various terms commonly used in fractography, failure analysis, and biomechanics. Fractography offers a wealth of information and the potential for better understanding bone trauma, and alignment of terminology and principles in the two fields is a necessary step on this new and exciting path.

*References*

- Berryman HE. A systematic approach to the interpretation of gunshot wound trauma to the cranium. *Forensic Science International* 2019;301:306-317.
- Berryman HE, Berryman JF, Saul T. Bone trauma analysis in a forensic setting: theoretical basis and a practical approach for evaluation. In Boyd CC, Boyd DC, editors: *Forensic Anthropology: Theoretical Framework and Scientific Basis*. Hoboken: Wiley & Sons Ltd; 2018.
- Berryman HE, Symes SA. Recognizing gunshot and blunt cranial trauma through fracture interpretation. In Reichs KJ, editor: *Forensic Osteology: Advances in the Identification of Human Remains*. Springfield: Charles C. Thomas, 1998:333–352.
- Berryman HE, Mincer HH, Moore JS. Forensic characteristics of antemortem, perimortem and postmortem dental fractures. In: Proceedings of the 43rd Annual Meeting of the American Academy of Forensic Sciences, 1991; Anaheim, CA.
- Berryman HE, Symes SA, O. C. Smith, Moore SJ. Bone fracture II: Gross examination of fractures. In: Proceedings of the 43rd Annual Meeting of the American Academy of Forensic Sciences, 1991; Anaheim, CA.
- Berryman HE, Smith OC, Symes SA. Biomechanics of Fracture Production, In: Proceedings of the 42nd Annual Meeting of the American Academy of Forensic Sciences, 1990; Cincinnati, OH.

Bird CE, Fleischman JM. A rare case of an intact bone plug associated with a gunshot exit wound.

*Journal of Forensic Sciences* 2015; 60 (4): 1074-1077.

Braidotti P, Branca FP, Stagni L. Scanning electron microscopy of human cortical bone failure

surfaces. *Journal of Biomechanics* 1997;30(2):155-162.

Braidotti P, Bemporad E, D'Alessio T, Sciuto SA, Stagni L. Tensile experiments and SEM

fractography on bovine subchondral bone. *Journal of Biomechanics* 2000;33(9):1153–1157.

Burr DB, Schaffler MB, Frederickson RG. Composition of the cement line and its possible

mechanical role as a local interface in human compact bone. *Journal of Biomechanics* 1988;21(11):939–945.

Byers SN. *Introduction to Forensic Anthropology*. Allyn and Bacon, Boston; 2002.

Chaudhri MM. Dynamic fracture of inorganic glasses by hard spherical and conical projectiles.

*Philosophical Transactions R* 2015;373: 20140135.

<http://dx.doi.org/10.1098/rsta.2014.0135>

Christensen AM, Hefner JT, Smith MA, Webb JB, Bottrell MC, Fenton TW. Forensic fractography

of bone: A new approach to skeletal trauma analysis. *Forensic Anthropology* 2018;1(1):32-51.

Christensen AM, Hatch GM. Forensic fractography of bone using CT scans. *Journal of Forensic*

*Radiology and Imaging* 2019;18:37-39.

Christensen AM, Decker SJ. Forensic fractography of bone using CT scans. *Proceedings of the 72nd Annual Meeting of the American Academy of Forensic Sciences*, February 17-22, 2020; Anaheim, CA.

Christensen AM, Passalacqua NV. *A Laboratory Manual for Forensic Anthropology*. Elsevier-Academic Press: San Diego CA; 2018.

Corondan G, Haworth WL. A fractographic study of human long bone. *Journal of Biomechanics* 1986;19(3):207–218.

Currey J D. *Bones: Structure and Mechanics*. New Jersey: Princeton University Press; 2002.

Fischer-Cripps AC. *Introduction to Contact Mechanics*. Mechanical Engineering Series. Boston: Springer, 2007.

Frank FC, Lawn BR. On the theory of Hertzian fracture. *Proceedings of the Royal Society*, 1967;299:291-306.

Gurdjian ES, Lissner HR, Webster JE. The mechanism of production of linear skull fracture; further studies on deformation of the skull by the stresscoat technique. *Surgery, Gynecology, & Obstetrics* 1947;85:195–210.

Gurdjian ES, Webster JE, Lissner HR. The mechanism of skull fracture. *Radiology* 1950;54:313–339.

Hart GO. Fracture pattern interpretation in the skull: differentiating blunt force from ballistics trauma using concentric fractures. *Journal of Forensic Sciences* 2005;50(6):1276-1281.

Hertz H. *Miscellaneous Papers*, 1896. Translation by Jones DE, Schott GH. London: Macmillan and Co. Ltd.

Hull D. *Fractography: observing, measuring and interpreting fracture surface topography*. Cambridge University Press, Cambridge; 1999.

Isa MA, Fenton TW, Antonelli L, Vaughan PE, Wei F. The application of fractography in trauma analysis of complex long bone fractures. *Proceedings of the 72nd Annual Meeting of the American Academy of Forensic Sciences*, February 17-22, 2020; Anaheim, CA.

Isa MI, Fenton TW, Goots AC, Watson EO, Vaughan PE, Wei F. Experimental investigation of cranial fracture initiation in blunt human head impacts. *Forensic Science International* 2019;300:51-62.

Isa MI, Fenton TW, Deland T, Haut RC. Assessing impact direction in 3-point bending of human femora: incomplete butterfly fractures and fracture surfaces. *Journal of Forensic Science* 2018;63(1):38-46.

Kieser DC, Riddell R, Kieser JA, Theis J, Swain MV. Bone microfracture observations from direct impact of slow velocity projectiles. *Journal of Archives in Military Medicine* 2014;2(1):e15614.

Knight CG, Swain MV, Chaudhri MM. Impact of small steel spheres on glass surfaces. *Journal of Materials Science* 1977;12:1573-1586.

Komar DA, Buikstra JE. *Forensic Anthropology: Contemporary Theory and Practice*. New York: Oxford University Press Inc.; 2008.

- Kroman A, Kress T, Porta D. Fracture propagation in the human cranium: a re-testing of popular theories. *Clinical Anatomy* 2011;24:308-318.
- Kieser JA, Tahere J, Agnew C, Kieser DC, Duncan W, Swain MV, Reeves MT. Morphoscopic analysis of experimentally produced bony wounds from low velocity ballistic impact. *Forensic Science, Medicine and Pathology* 2011;7:322-332.
- Kimmerle EH, Baraybar J P. *Skeletal Trauma: Identification of Injuries Resulting from Human Rights Abuses and Armed Conflict*. Boca Raton: CRC Press; 2008.
- Kimura T, Ogawa K, Kamiya M. Fractography of human intact long bone by bending. *Zeitschrift Rechtsmedizin* 1977;79:301–310.
- L'Abbé EN, Symes SA, Raymond DE, Ubelaker DH. The Rorschach butterfly, understanding bone biomechanics prior to using nomenclature in bone trauma interpretations. *Forensic Science International* 2019;299:187-194.
- Lawn BR. Indentation of ceramics with spheres: a century after Hertz. *Journal of the American Ceramic Society* 1998;81(8):1977-1994.
- Lillard K, Christensen AM. Fractography of long bones with high velocity projectile trauma. *Forensic Anthropology* 2020;In Press.
- Love JC, Christensen AM. Application of bone fractography to a medical examiner sample: A case series. *Forensic Anthropology* 2018;1(4):221-227.
- Martens M, van Audekercke R, de Meester P, Mulier JC. Mechanical behavior of femoral bones in bending loading. *Journal of Biomechanics* 1986;19(6):443–454.

Mayamoto A, Murakami Y. The morphology of the Hertzian cone in plate glass. *Journal of the Society of Materials Science, Japan* 2000;49(8):867-872.

Morgan EF, Unnikrisnan GU, Hussein AI. Bone mechanical properties in healthy and diseased states. *Annual Review of Biomedical Engineering* 2018;20:119-143.

Murphy MS, Gaither C, Goycochea E, Verano JW, Cock G. Violence and weapon-related trauma at Puruchuko-Huaquerones, Peru. *American Journal of Physical Anthropology* 2010; 142:636-649.

Murphy MS, Spatola B, Weathermon R. Allies today, enemies tomorrow: a comparative analysis of perimortem injuries along the biomechanical continuum. In Martin DL, Anderson CP (eds): *Bioarchaeological and Forensic Perspectives on Violence: How Violent Death is Interpreted from Skeletal Remains*. Cambridge: Cambridge University Press; 2014:261-288.

Palmqvist S. Method att bestamma segheten hos sproda material, sarskilt hardmetaller. *Jernkontorets Annaler* 1957;141:300-307.

Pechníková, M, Mazzarelli D, Poppa P, Gibelli D, Scossa Baggi E, Cattaneo C. Microscopic pattern of bone fractures as an indicator of blast trauma: a pilot study. *Journal of Forensic Sciences* 2015;60(5):1140-1145.

Peterson BL. External beveling of cranial gunshot entrance wounds. *Journal of Forensic Sciences* 1991;36(5):1592-1595.

Piekarski K. Fracture of bone. *Journal of Applied Physics* 1970;41:215-223.

- Pope MH, Outwater JO. The fracture characteristics of bone substance. *Journal of Biomechanics* 1972;5:457–465.
- Powell BJ, Passalacqua NV, Baumer TG, Fenton TW, Haut RC. Fracture patterns on the infant porcine skull following severe blunt impact. *Journal of Forensic Sciences* 2012;57(2):312-317.
- Quatrehomme G, Piercecchi-Marti MD, Buchet L, Alunni V. Bone beveling cause by blunt trauma: a case report. *International Journal of Legal Medicine* 2016;130(3):771-775.
- Quatrehomme G, İşcan MY. Analysis of bevelling in gunshot entrance wounds. *Forensic Science International* 1998;93:45-60.
- Quinn GD. *NIST Recommended Practice Guide: Fractography of Ceramics and Glasses*, 2nd Ed. National Institute of Standards and Technology; 2016.
- Rhine S, Curran BK. Multiple gunshot wounds to the head: An anthropological review. *Journal of Forensic Sciences* 1990;35(3):1236-1245.
- Rickman JM, Shackel J. A novel hypothesis for the formation of conoidal projectile wounds in sandwich bones. *International Journal of Legal Medicine* 2019a;133:501-519.
- Rickman JM, Shackel J. Crack propagation through sandwich bones due to low-velocity projectile impact. *International Journal of Legal Medicine* 2019b;133:1443-1459.
- Shattock SG. The disruptive phenomena in gunshot injuries; their physics. *Proceedings of the Royal Society of Medicine*. 1923;16 (Pathology section):17-34

Smith OC, Symes SA, Berryman HE, LeVaughn MA. Matching bullets to bone impact signatures. *Journal of Forensic Sciences* 1991;36(6):1736-1739.

Smith OC, Berryman HE, Symes SA, Francisco JT, Hnilica V. Atypical gunshot exit defects to the cranial vault. *Journal of Forensic Sciences* 1993;38(2):339-343.

Smith OC, Berryman HE, Symes SA, Francisco JT, Hnilica VS. Atypical gunshot exit defects to the cranial vault. In: Proceedings of the 44th Annual Meeting of the American Academy of Forensic Sciences, 1992; New Orleans, LA.

Smith O C, Berryman HE, Symes SA, Moore SJ. Bone fracture I: The physics of fracture, In: Proceedings of the 43rd Annual Meeting of the American Academy of Forensic Sciences, 1991; Anaheim, CA.

Spatola BF. Atypical gunshot and blunt force injuries: wounds along the biomechanical continuum. In Passalacqua NV, Rainwater CW (eds): *Skeletal trauma analysis: case studies in context*. West Sussex: John Wiley & Sons; 2015:7-26.

Spitz WU. Injuries by gunfire. In Spitz WU, Spitz DJ, Clark R (eds): *Spitz and Fisher's medicolegal investigation of death: guidelines for the application of pathology to crime investigation*. Springfield: Charles C Thomas Publishers; 2006

Symes SA, L'Abbé EN, Chapman EN, Wolff I, Dirkmaat DC. Interpreting traumatic injuries to bone in medicolegal investigations. In Dirkmaat DC (ed): *A Companion to Forensic Anthropology*. West Sussex: Wiley- Blackwell Publishing; 2012.

- Symes SA, Smith OC, Berryman HE, Moore SJ. Bone fracture III: Microscopic fracture analysis of bone. In: Proceedings of the 43rd Annual Meeting of the American Academy of Forensic Sciences, 1991; Anaheim, CA.
- Ubelaker DH. Recent advances in understanding hard tissue alterations related to trauma. *Forensic Science International* 2019;299:235-237.
- Vashishth D, Behiri J, Bonfield W. Crack growth resistance in cortical bone: concept of microcrack toughening. *Journal of Biomechanics* 1997;30:763–9.
- Vermeij EJ, Zoon PD, Chang SBCG, Chang SBCG, Keereweer I, Pieterman R, Gerretsen RRR. Analysis of microtraces in invasive traumas using SEM/EDS. *Forensic Science International* 2012;214(1):96-104.
- Vural M. Impact failure phenomenology of alumina ceramic targets. In Allison IM (ed): *Experimental Mechanics: Advances in Design, Testing and Analysis – Proceedings of the 11<sup>th</sup> International Conference on Experimental Mechanics*. Netherlands: AA Balkema, 1998.
- Wise LM, Wang Z, Grynpas. The use of fractography to supplement analysis of bone mechanical properties in different strains of mice. *Bone* 2007;41(4):620–630.
- Zaera R, Sánchez-Gálvez V. Analytical modelling of normal and oblique ballistic impact on ceramic/ metal lightweight armours. *International Journal of Impact Engineering* 1998;21(3):133-148.

Zimmermann EA, Gludovatz B, Schaible E, Busse B, Ritchie RO. Fracture resistance of human cortical bone across multiple length scales at physiological strain rates. *Biomaterials* 2014;35: 5472-5481

Zukas JA. Penetration and perforation of solids. In Zukas JA, Nicholas T, Swift HF, Greszczuk LB, Curran DR (eds): *Impact dynamics*, John Wiley and Sons, Inc.; 1982:155- 214.

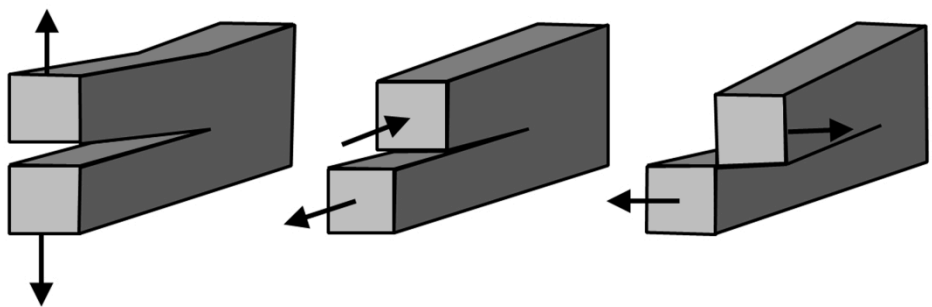

Figure 1: Fracture modes: Mode I – opening (left); Mode II – shearing (center); and Mode III – tearing (right)

254x95mm (300 x 300 DPI)

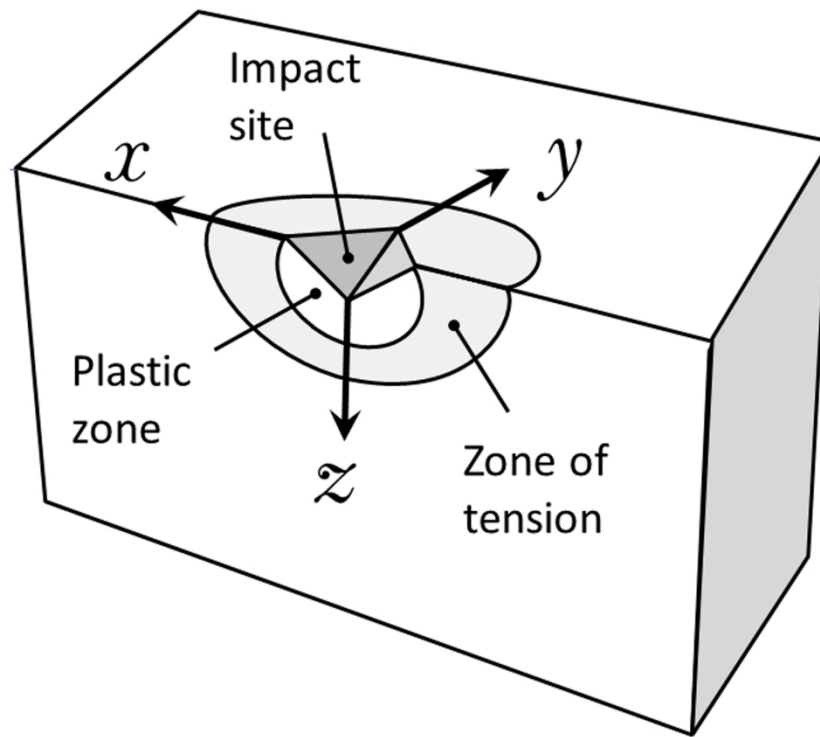

Figure 2: Cross-section of impact site showing triaxial stresses and zone of tension

254x211mm (300 x 300 DPI)



Figure 3: Crack origin at the site of a nutrient foramen opening; solid arrow indicates the nutrient foramen opening on a posterior human femur, bracket indicates the mirror zone, and the dashed arrow indicates the direction of crack propagation.

203x207mm (300 x 300 DPI)

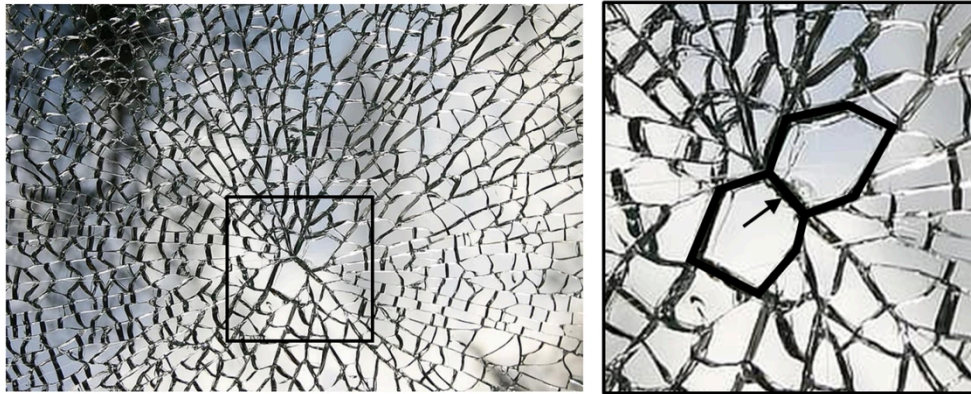

Figure 4: Fracture origin in tempered glass. Tempered glass is treated such that the outer surfaces are in compression and the interior is in tension. When failure in tempered glass is triggered by an impact, a surface crack is driven through the surface compression temper zone and into the interior tensile zone. The glass then spontaneously fractures into many small fragments due to the internal tensile stresses. The glass at the origin site cracks with branches forming adjacent polyhedrons that are larger and have a greater number of sides (usually >4) than the other fragments. The right image shows an enlargement of the boxed area on the left, with the polyhedral outlines highlighted, and the arrow indicating the fracture origin.

254x107mm (300 x 300 DPI)

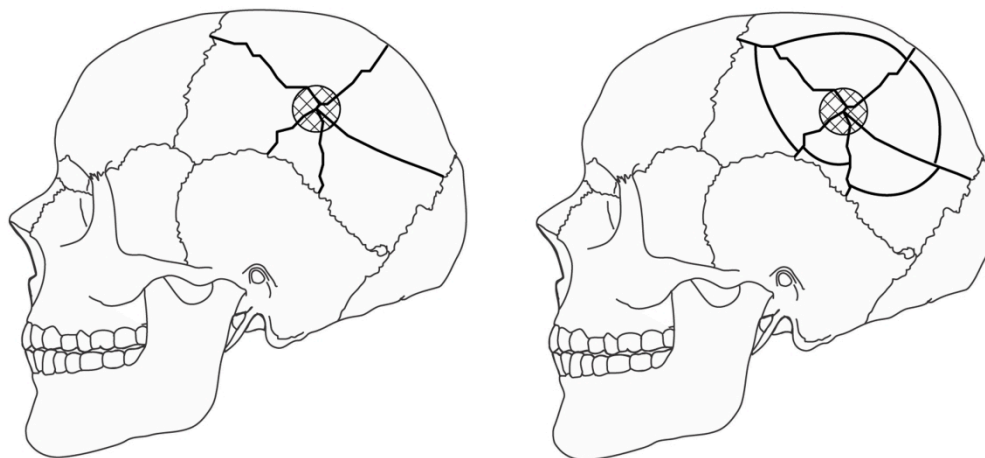

Figure 5: Radial (left) and circumferential (right) fractures in bone associated with an impact (shaded area) (modified from Christensen et al. 2019)

254x119mm (300 x 300 DPI)

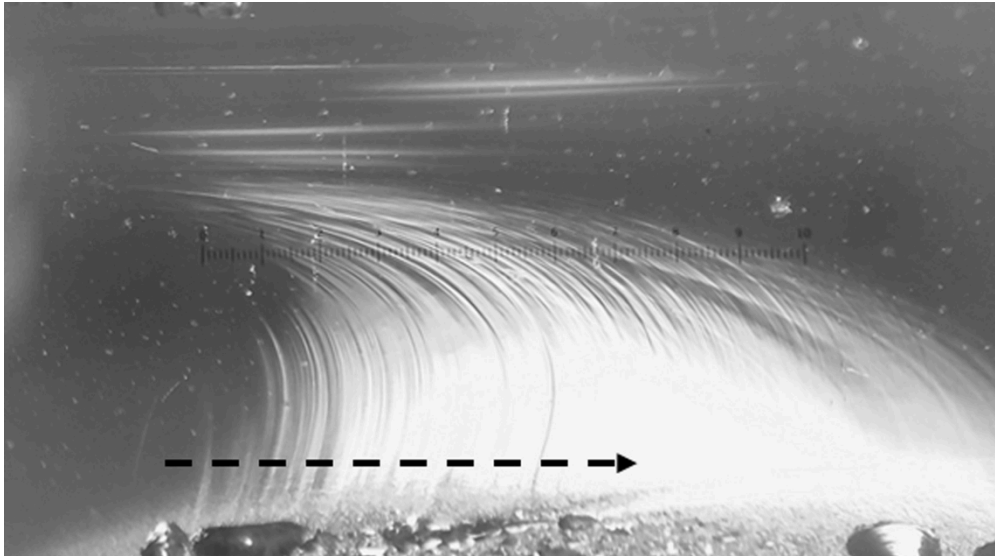

Figure 6: Wallner lines in glass, which are concentric about the fracture origin (which is to the left of the image, with the crack traveling left to right)

203x112mm (300 x 300 DPI)

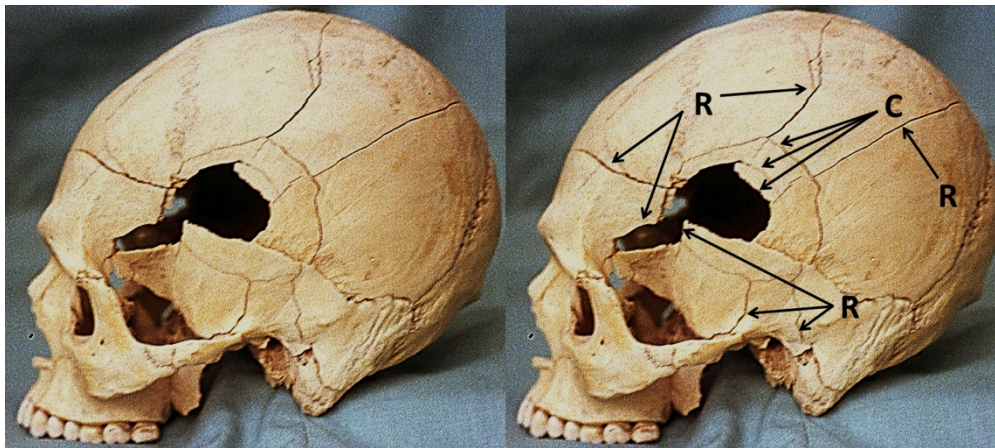

Figure 7: Gunshot trauma to a cranium (left), showing radial (R) and concentric (C) fractures (right)

254x113mm (300 x 300 DPI)

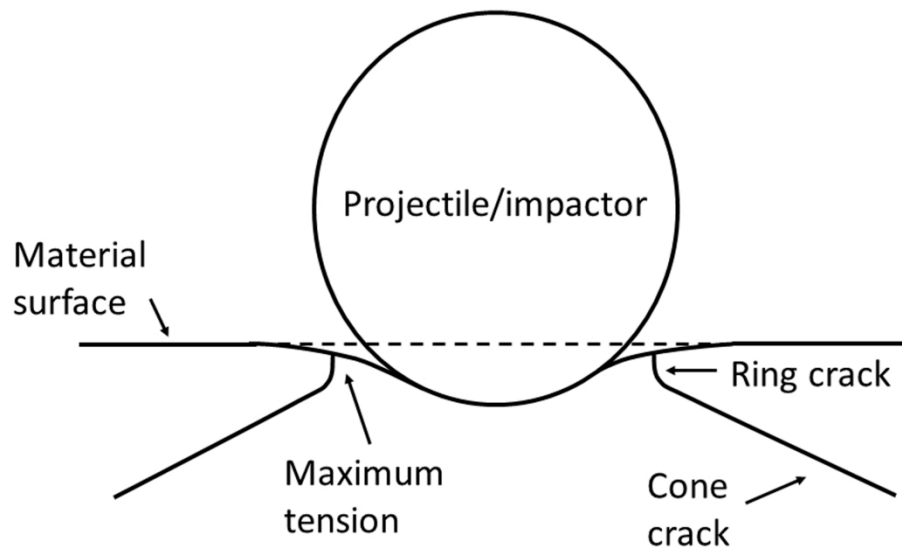

Figure 8: Schematic of a cone crack, including ring crack initiating just outside the impact zone, and flaring outward into a cone.

254x162mm (300 x 300 DPI)

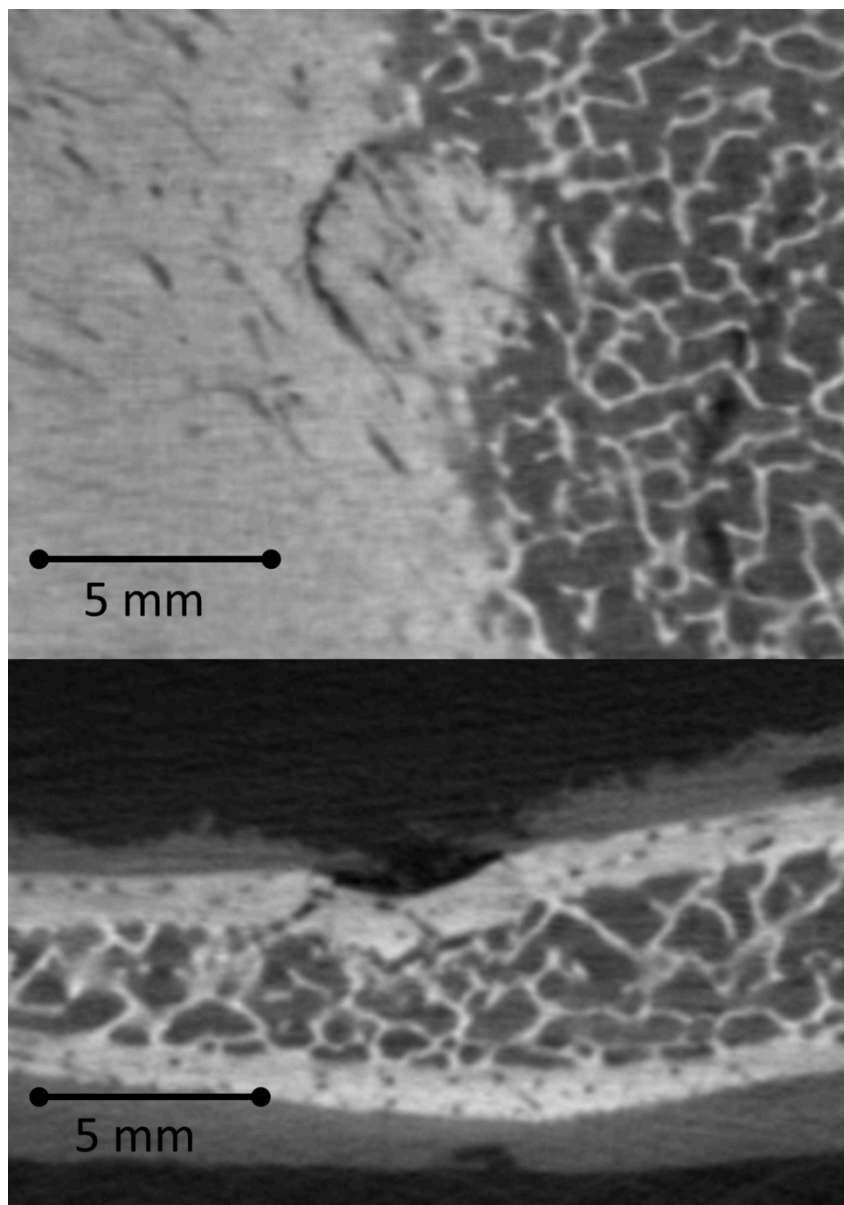

Figure 9: Ring crack with incomplete cone crack in the cortical lamina of bone impacted with 6 mm surface hardened carbon steel sphere at an incident velocity 55 m/s shown in micro-computerized tomography ( $\mu$ CT); top: transverse-sectional view from impact side; bottom: cross-sectional view.

179x254mm (300 x 300 DPI)

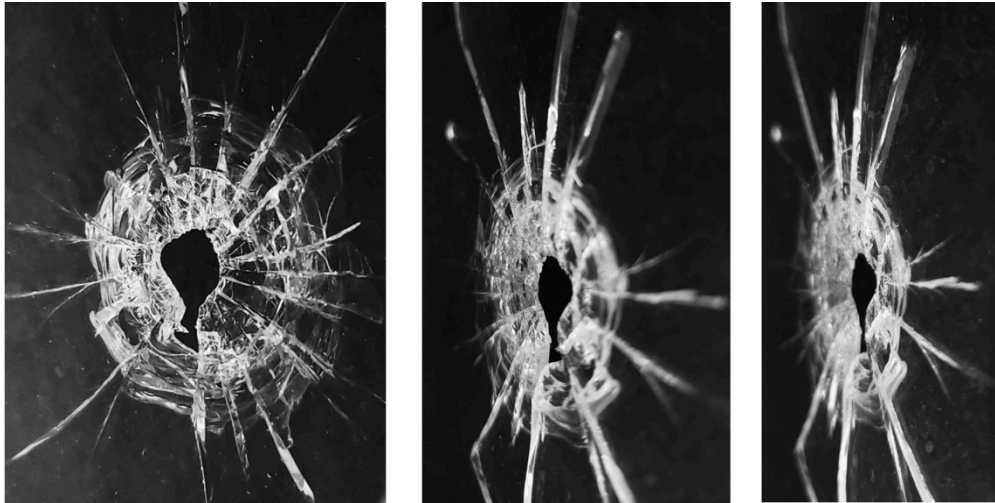

Figure 10: Cone crack and conoidal bevel (as well as radial and circumferential cracks) in glass from a projectile; left: view from projectile entrance with the bevel away from the viewer; middle and right: two oblique views of the exit with the bevel toward the viewer

254x127mm (300 x 300 DPI)



Figure 11: Conoidal bevel in bone from a projectile exit on a human cranium (from Christensen & Passalacqua 2018)

254x253mm (300 x 300 DPI)

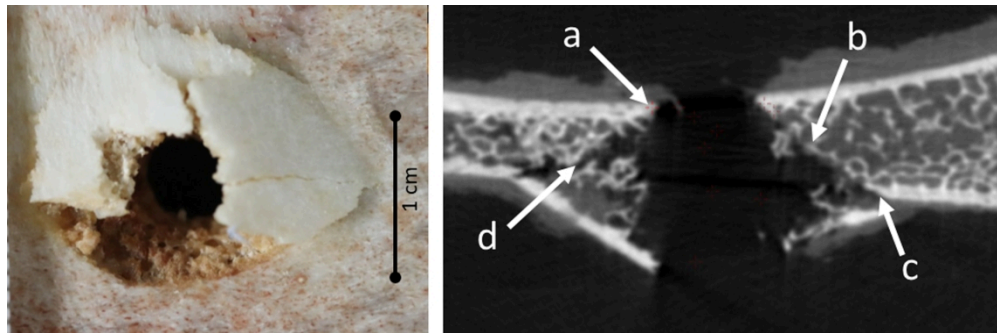

Figure 12: Cone crack in adult porcine scapula impacted with 6 mm surface hardened carbon steel sphere at 158 m/s. Left: View of exit side of impact with bevel and fragments of the cortical floor of the conoid still in situ and nearly fully covering the bevel; Right:  $\mu$ CT transverse-section of the same beveled fracture showing the entry cortical fracture edge (a), the trabecular fracture margin (b), the exit cortical fracture edge (c), and the bevel present behind the lower left fragment (d); this fracture margin could not be shielded behind a fragment if the bevel were formed by a physical interaction with a cortical shear plug.

254x83mm (300 x 300 DPI)

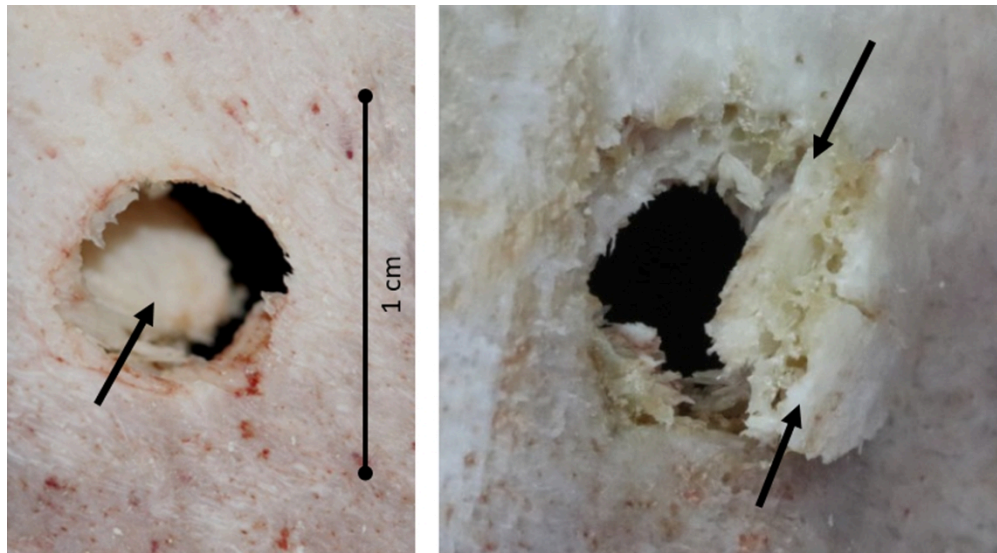

Figure 13: Cone crack in adult porcine scapula impacted with 6 mm surface hardened carbon steel sphere at 75 m/s. Left: entry fracture with cortical roof of displaced conoid (arrow) visible through the cortical entry; and right: conoid of the same fracture viewed from the side showing outer (top arrow) and inner (bottom arrow) cortical layers with trabecular lamina in the middle (see Rickman and Shackel 2019b for  $\mu$ -CT analysis of this conoid).

203x112mm (300 x 300 DPI)

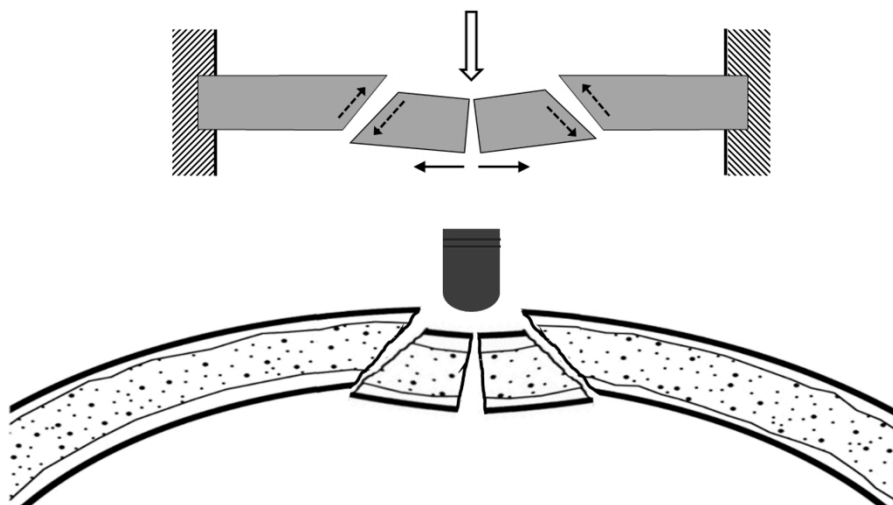

Figure 14: Shear forces causing cracks to angle toward fixed or cantilevered ends. Top: a beam with two fixed/cantilevered ends loaded by a force (open arrow) creating tension on the opposite side (solid arrows) where the fracture initiates, with shear forces (dashed arrows) contributing to the fractures angling toward the fixed ends; Bottom: similar angled/beveled fracture propagation in a cranial bone impacted by a projectile.

254x142mm (300 x 300 DPI)

# Forensic fractography of bone: fracture origins from impacts, and an improved understanding of the failure mechanism involved in beveling

Christensen, Angi M.

2021-07-23

---

Christensen AM, Rickman JM, Berryman HE. (2021) Forensic fractography of bone: fracture origins from impacts, and an improved understanding of the failure mechanism involved in beveling. *Forensic Anthropology*, Volume 4, Number 1, July 2021, Pages 57–69

<https://doi.org/10.5744/fa.2020.0041>

*Downloaded from CERES Research Repository, Cranfield University*