

CRANFIELD UNIVERSITY

ADRIAN URIONDO DEL POZO

DEVELOPMENT OF A QUALIFICATION PROCEDURE, AND  
QUALITY ASSURANCE AND QUALITY CONTROL CONCEPTS  
AND PROCEDURES FOR REPAIRING AND REPRODUCING  
PARTS WITH ADDITIVE MANUFACTURING IN MRO  
PROCESSES

SCHOOL OF AEROSPACE, TRANSPORT AND  
MANUFACTURING

MSc by Research Thesis  
Academic Year: 2014 - 2015

Supervisor: Dr. Suresh Perinpanayagam

March 2015

CRANFIELD UNIVERSITY

SCHOOL OF AEROSPACE, TRANSPORT AND  
MANUFACTURING

MSc by Research Thesis

Academic Year 2014 - 2015

ADRIAN URIONDO DEL POZO

Development of a Qualification Procedure, and Quality Assurance  
and Quality Control concepts and procedures for repairing and  
reproducing parts with additive manufacturing in MRO processes

Supervisor: Dr. Suresh Perinpanayagam  
March 2015

This thesis is submitted in partial fulfilment of the requirements for  
the degree of Master of Science

© Cranfield University 2015. All rights reserved. No part of this  
publication may be reproduced without the written permission of the  
copyright owner.

## **ABSTRACT**

This MSc by Research is focused mainly on Quality Assurance (QA) and Qualification Procedures for metal parts manufactured using new Additive Manufacturing (AM) techniques in the aerospace industry. The main aim is to understand the state of the art of these technologies and the strong regulatory framework of this industry in order to develop correct QA/QC procedures in accordance with the certification process for the technology and spare parts. These include all the testing and validation necessary to implement them in the field, as well as to maintain their capability throughout their lifecycle, specific procedures to manufacture or repair parts, workflows and records amongst others. At the end of this MSc by Research, an entire Qualification Procedure for Electron Beam Melting (EBM) and Selective Laser Melting (SLM) for reproduction of an aerospace part will be developed and defined. Also, General Procedures, Operational Instructions, and Control Procedures with its respective registers, activities, and performance indicators for both technologies will be developed. These will be part of the future Quality Assurance and Quality Management systems of those aerospace companies that implement EBM or SLM in their supply chain.

Keywords: Quality Assurance, Quality Management, Qualification, Selective Laser Melting, Electron Beam Melting, Aerospace Industry, MRO, Certification





## **ACKNOWLEDGEMENTS**

I would like to thank Dr. Suresh Perinpanayagam and Dr. Manuel Esperon Miguez at the IVHM Centre, for their supervision and help during this research. Thanks to Dr. Luis Portoles from AIMME and Dr. Jeppe Skinnerup from DTI for sharing with me the necessary knowledge about EBM and SLM respectively.

This work presented in this thesis has received funding from the European Union's Seventh Framework Programme (FP7/2007-2013) under grant agreement number 605779. This research was also supported in part by the IVHM Centre at Cranfield University.



# TABLE OF CONTENTS

|  |      |
|--|------|
| ABSTRACT .....   | i    |
| ACKNOWLEDGEMENTS.....  | iii  |
| LIST OF FIGURES.....   | viii |
| LIST OF TABLES .....   | xii  |
| LIST OF ABBREVIATIONS.....   | xiv  |
| PUBLICATIONS .....   | XVII |
| 1 INTRODUCTION.....  | 19   |
| 1.1 Background.....  | 19   |
| 1.2 Requirements for manufacturing in the aerospace industry .....             | 20   |
| 1.3 Economics and operative advantages of AM for the aerospace industry .....  | 21   |
| 1.4 Thesis outline.....  | 25   |
| 2 LITERATURE REVIEW .....  | 26   |
| 2.1 Introduction .....   | 26   |
| 2.2 Additive manufacturing .....   | 26   |
| 2.3 Classification of AM for metal components.....                             | 29   |
| 2.3.1 Electron Beam Melting .....  | 32   |
| 2.3.2 Selective Laser Melting .....  | 33   |
| 2.3.3 Comparison between SLM and EBM .....                                     | 33   |
| 2.3.4 Laser Metal Deposition .....   | 36   |
| 2.4 Aerospace alloys in AM processes.....                                      | 40   |
| 2.4.1 Titanium alloys .....  | 41   |
| 2.4.2 Nickel-based alloys .....  | 43   |
| 2.4.3 Fatigue, porosity and roughness.....                                     | 44   |
| 2.5 Modelling AM processes.....  | 45   |
| 2.5.1 Selective Laser Melting models .....                                     | 47   |
| 2.5.2 Electron Beam Melting models .....                                       | 50   |
| 2.5.3 Laser Metal Deposition models.....                                       | 52   |
| 2.6 Meso-scale material models .....   | 55   |
| 2.7 Certification in the aerospace market .....                                | 56   |
| 2.8 Current AM standards.....  | 60   |
| 2.9 Summary.....   | 65   |
| 3 Research objectives and methodology .....                                    | 67   |
| 3.1 Introduction .....   | 67   |
| 3.2 Aim and objectives.....  | 67   |
| 3.3 Problem statement.....   | 70   |
| 3.4 Methodology .....  | 72   |
| 3.4.1 Analysis of production, supply chain and workflow management system..... | 73   |
| 3.4.2 Repair processes .....   | 73   |

|   |     |
|---|-----|
| 3.4.3 Case studies .....  | 74  |
| 4 Qualification Procedure for AM .....                            | 79  |
| 4.1 Introduction .....  | 79  |
| 4.2 Qualification Procedure for EBM/SLM .....                     | 83  |
| 4.3 Boeing “bracket” Qualification Procedure .....                | 91  |
| 4.4 Case studies .....  | 109 |
| 4.4.1 Boeing “bracket” .....                                      | 109 |
| 4.4.2 CFM56 2/3 HTP shroud .....                                  | 119 |
| 4.4.3 Process specifications.....                                 | 121 |
| 5 QA/QC Procedures for EBM and SLM. ....                          | 126 |
| 5.1 Introduction .....  | 126 |
| 5.2 General QA procedures .....                                   | 128 |
| 5.2.1 Description of responsibilities.....                        | 128 |
| 5.2.2 Quotation and order management .....                        | 132 |
| 5.2.3 Identification and traceability of the product.....         | 138 |
| 5.2.4 Purchase management .....                                   | 141 |
| 5.2.5 Identification and traceability of raw materials .....      | 146 |
| 5.2.6 Control of measuring equipment .....                        | 149 |
| 5.2.7 Complaint management .....                                  | 151 |
| 5.2.8 Non-conformities, corrective, and preventive actions .....  | 152 |
| 5.2.9 Document management.....                                    | 156 |
| 5.2.10 Suppliers validation .....                                 | 158 |
| 5.2.11 Subcontracting management .....                            | 161 |
| 5.3 Operational instructions for EBM/SLM based supply chain ..... | 164 |
| 5.3.1 General build preparation.....                              | 165 |
| 5.3.2 Build preparation for EBM .....                             | 166 |
| 5.3.3 Build preparation for SLM .....                             | 168 |
| 5.3.4 Physical preparation of the EBM machine .....               | 170 |
| 5.3.5 Physical preparation of the SLM machine.....                | 172 |
| 5.3.6 Software preparation for EBM machine .....                  | 175 |
| 5.3.7 Software preparation of the SLM machine .....               | 176 |
| 5.3.8 Sandblasting the part .....                                 | 176 |
| 5.3.9 Support removal after build .....                           | 177 |
| 5.3.10 Post-processing procedure .....                            | 177 |
| 5.3.11 Powder handling, refreshing and storage .....              | 178 |
| 5.4 Control procedures for EBM/SLM-based supply chain .....       | 181 |
| 5.4.1 Powder quality control.....                                 | 181 |
| 5.4.2 Control of the manufacturing process .....                  | 182 |
| 5.4.3 Sandblasting control.....                                   | 186 |
| 5.4.4 Control of the final part.....                              | 187 |
| 6 Conclusions .....   | 189 |
| 6.1 Discussion of the research.....                               | 189 |

|   |     |
|---|-----|
| 6.2 Future work .....   | 192 |
| REFERENCES .....  | 193 |
| APPENDICES .....  | 205 |
| Appendix A Current Repair Process for the HTP Shroud CFM56 -2/3 ..... | 205 |
| Appendix B Process Flowchart .....                                    | 206 |
| Appendix C Registers .....  | 207 |
| Appendix D Examples of Build Report and Log Data .....                | 218 |
| Appendix E EBM/SLM Relevant Variables .....                           | 220 |

## LIST OF FIGURES

|  |    |
|--|----|
| Figure 1-1 (a) Near-shape process of AM permits reducing the raw material to produce a part. (b) Near-shape HPC blade. [8].....  | 22 |
| Figure 1-2 Breakeven analysis performed by Atzeni et al., 2012 comparing HPDC and SLM processes. [14].....   | 23 |
| Figure 1-3 Visual illustration of supply chain configuration. (a) Centralized, single manufacturing site. (b) Distributed, manufacturing capability at every service facility. [1] ..... | 24 |
| Figure 2-1 Units of AM machines for metal part sales by year. [37].....  | 27 |
| Figure 2-2 Final AM production parts for directly assembly. [37] .....   | 28 |
| Figure 2-3 Classification of AM processes based on different energy source and powder delivery system. ....  | 30 |
| Figure 2-4 Optical Absorption (%) of selected metal vs wavelength. [23] .....  | 31 |
| Figure 2-5 (a) EBM and (b) SLM systems schematics. (c) Atomized Cu powder (Scanning Electron Microscope, SEM image). ....  | 33 |
| Figure 2-6 Representative CoCrMo SLM microstructure ( <i>left</i> , courtesy EOS), and Ti6Al4V EBM microstructure ( <i>right</i> , courtesy Arcam AB).[23] .....                         | 36 |
| Figure 2-7 Schematic of a typical beam deposition process. [23] .....  | 37 |
| Figure 2-8 (a) Co-axial nozzle feeding and (b) single-nozzle feeding. [23] .....   | 38 |
| Figure 2-9 CoCrMo deposit on CoCrMo: (a) side view and (b) top view of deposit. [23] .....   | 38 |
| Figure 2-10 Cracks formation in (a) LMD-processed Rene 88DT and (b) SLM processed Waspaloy. (c) LENS-deposited Ti/TiC (4 layers on top of a Ti substrate). [23].....                     | 39 |
| Figure 2-11 (a)CFM-56 HTP Shroud before LMD processing, (b) filling strategy and (c) LMD-processed shroud. [8] .....   | 40 |
| Figure 2-12 (a) Ti6Al4V fabricated by EBM. (b) Ti6Al4V fabricated by SLM. (c) The TEM image for EBM-fabricated Ti6Al4V shows high dislocation density in $\alpha$ -phase. [49].....      | 42 |
| Figure 2-13 Engineering stress-strain curves for Ti6Al4V and Ti6Al4V10Mo produced by SLM. [66] .....   | 43 |
| Figure 2-14 Detailed model map for AM processes. ....  | 47 |
| Figure 2-15 Predicted Ti-6Al-4V grain morphology for low laser power (LENS) of Bulky 3-D from (a) 3-D Rosenthal Solution and (b) 3-D FEM. [26].....                                      | 48 |
| Figure 2-16 Comparison of porosity in experiment and simulation. [79] .....  | 49 |

|   |    |
|---|----|
| Figure 2-17 (a) Top view of temperature field of EBM at a constant beam current of 14mA for different scanning velocities (100, 500 and 1000 m/s). (b) Comparison of the heat distribution and fluid convection inside the molten pool (14mA and 100 m/s). (c) Section of a compact 15×15 mm wall produced by EBM of Ti6Al4V powder utilizing a 60 kV electron beam at a line of 0.3 J/mm. The 2D LBM simulation result is shown at the top right with the same scale as the experiment. [84] ..... | 51 |
| Figure 2-18 (a) Experimental vs simulated data width track. (b) Experimental vs simulated temperatures in the thermocouple model. [86].....   | 53 |
| Figure 2-19 Comparison between (a) experimental (1000 Hz c-Mos fast camera) and (b) simulated-induced melt-pools (600 W, 0.006 m s <sup>-1</sup> ), between the 2 <sup>nd</sup> and the 8 <sup>th</sup> manufactured layers. [86].....  | 53 |
| Figure 2-20 Processing maps for Ti6Al4V. Experimental results and mesoscopic simulations for SLM. [90] .....  | 55 |
| Figure 2-21 CA predicted and observed microstructure in thin-wall LENS <sup>TM</sup> (Q=370 W, V=12.5 mm/s). [26].....  | 56 |
| Figure 2-22 Components of the new aviation safety agreement format. [94]....  | 57 |
| Figure 2-23 EASA regulations. [93].....   | 59 |
| Figure 2-24 ASTM plan to develop AM standards. ....   | 61 |
| Figure 3-1 Influence of the regulatory framework in the RepAIR concept.....   | 70 |
| Figure 3-2 Feasible implementation strategy. ....   | 72 |
| Figure 4-1 Thesis overview. ....  | 80 |
| Figure 4-2 Manufacturing an aircraft component considering AM technologies. ....  | 81 |
| Figure 4-3 Repairing an aircraft component considering AM technologies. ....  | 82 |
| Figure 4-4 General approach for the Process Qualification Procedure.....  | 83 |
| Figure 4-5 Preliminary definition of AM process parameters classified in groups. ....   | 86 |
| Figure 4-6 Definition of the studies to be carried out for AM qualification (manufacturing). ....   | 89 |
| Figure 4-7 Definition of the studies to be carried out for AM qualification (repair). ....  | 90 |
| Figure 4-8 Boeing bracket-Value stream qualification procedure for EBM. ....  | 92 |
| Figure 4-9 Boeing bracket-Value stream qualification procedure for SLM.....   | 93 |
| Figure 4-10 Ti6Al4V chemical composition after processing. [101] .....  | 94 |

|  |     |
|--|-----|
| Figure 4-11 Ti6Al4V property into the allowance range .....  | 97  |
| Figure 4-12 References for Technology and Material Qualification Procedure (QP) for Ti64 grade 5. ....   | 103 |
| Figure 4-13 References for “AM Technology”. ....   | 103 |
| Figure 4-14 References for “Material”. ....  | 104 |
| Figure 4-15 References for “Geometry”, specific “Original files”. ....   | 104 |
| Figure 4-16 References for “Geometry (Sliced file)”. ....  | 105 |
| Figure 4-17 References for “Build Samples”. ....   | 105 |
| Figure 4-18 References for “Post-processing”. ....   | 106 |
| Figure 4-19 References for “Build Platform (repetition number)”. ....  | 106 |
| Figure 4-20 References example. ....   | 107 |
| Figure 4-21 QR Code example. ....  | 107 |
| Figure 4-22 Example of internal defects in a conventional welding. ....  | 108 |
| Figure 4-23 BOE Bracket drawing.....   | 109 |
| Figure 4-24 Technology/material qualification platform configuration. ....   | 116 |
| Figure 4-25 (a) EBM building platform 1. (b) Tensile “z” and microstructure witness specimens. (c) Chemical composition witness specimens..... | 118 |
| Figure 4-26 (a) SLM building platform 1. (b) “Bracket” machined. ....  | 119 |
| Figure 4-27 HTP shroud.....  | 120 |
| Figure 4-28 Current repair process. All the activities inside the red box will be substituted by AM. ....                                      | 125 |
| Figure 5-1 Thesis overview. ....   | 128 |
| Figure 5-2 Quotation and order management flowchart.....   | 134 |
| Figure 5-3 Purchase management procedure flow chart. ....  | 142 |
| Figure 5-4 Shape of the tester.....  | 148 |
| Figure 5-5 Non conformities, corrective and preventive actions. ....   | 153 |
| Figure 5-6 Supplier validation flow chart. ....  | 159 |
| Figure 5-7 Subcontracts management flow chart.....   | 162 |
| Figure 5-8 Status report model. EBM machine. ....  | 182 |
| Figure 5-9 Event report. EBM machine. ....   | 183 |
| Figure 5-10 Sensor data. SLM machine. ....   | 184 |



|   |     |
|---|-----|
| Figure 5-11 Process properties. SLM machine. .... | 185 |
| Figure 5-12 Message window. SLM machine. ....     | 185 |
| Figure 5-13 Scanner Information. SLM Machine..... | 186 |
| Figure 6-1 Qualification procedure overview.....  | 191 |
| Figure D-0-1 Offset to part. ....                 | 222 |
| Figure D-0-2 Hatch strategies. ....               | 222 |
| Figure D-0-3 Randomise hatch. ....                | 223 |
| Figure D-0-4 Mean current. ....                   | 224 |
| Figure D-0-5 Offset.....                          | 226 |
| Figure D-0-6 Thickness function. ....             | 227 |
| Figure D-0-7 Squares.....                         | 229 |

## LIST OF TABLES

|  |     |
|--|-----|
| Table 2-1 Different Terminology for SLM, EBM and LMD. [36].....  | 31  |
| Table 2-2 Differences between EBM and SLM. [23] .....  | 36  |
| Table 2-3 Alloys for various AM processes. ....  | 40  |
| Table 2-4 Static mechanical properties of Ti6Al4V without any post-process in the build direction.. .... | 43  |
| Table 2-5 Static mechanical properties of IN645 achieved by EBM. [40] .....                              | 44  |
| Table 2-6 Static mechanical properties of IN718 for SLM and EBM. [70] .....                              | 44  |
| Table 2-7 Collection of AM standards. ....   | 62  |
| Table 3-1 General QA/QC steps. ....  | 69  |
| Table 3-2 Case studies. ....   | 77  |
| Table 4-1 Powder tests based on corresponding standards. ....  | 95  |
| Table 4-2 Chemical composition test and standards. ....  | 96  |
| Table 4-3 Bulk material tests and standards. ....  | 98  |
| Table 4-4 BOE bracket process specifications.....  | 110 |
| Table 4-5 HTP data specifications. ....  | 121 |
| Table 5-1 Technical roles. ....  | 129 |
| Table 5-2 Potential quality risks associated with procedure 5.2.1.....                                   | 132 |
| Table 5-3 Potential quality risks associated with procedure 5.2.2.....                                   | 137 |
| Table 5-4 Steps involved in the identification and traceability of the product..                         | 138 |
| Table 5-5 Potential quality risks associated with procedure 5.2.3.....                                   | 140 |
| Table 5-6 Performance indicator for the 5.2.3 procedure.....   | 141 |
| Table 5-7 Potential quality risks associated with procedure 5.2.4.....                                   | 145 |
| Table 5-8 suggests the following performance indicator for this procedure. ...                           | 146 |
| Table 5-9 Performance indicator for procedure 5.2.4.....   | 146 |
| Table 5-10 Potential quality risks associated with procedure 5.2.5.....                                  | 149 |
| Table 5-11 Potential quality risks associated with procedure 5.2.6.....                                  | 151 |
| Table 5-12 Potential quality risks associated with procedure 5.2.8.....                                  | 155 |
| Table 5-13 Performance indicators for procedure 5.2.8.....   | 156 |

|   |     |
|---|-----|
| Table 5-14 Fundamental documents of the quality system .....                          | 156 |
| Table 5-15 Potential quality risks associated with procedure 5.2.9.....               | 158 |
| Table 5-16 Suppliers qualification .....  | 160 |
| Table 5-17 Performance indicator for procedure 5.2.10.....                            | 161 |
| Table 5-18 External aspect to control during the preparation of the EBM machine ..... | 167 |
| Table 5-19 External aspect to control during the preparation of the SLM machine ..... | 169 |

## LIST OF ABBREVIATIONS

|      |                                   |
|------|-----------------------------------|
| AM   | Additive Manufacturing            |
| AMC  | Acceptable Means of Compliance    |
| AMT  | Aircraft Maintenance Technician   |
| CA   | Cellular Automaton                |
| CAD  | Computer Aided Design             |
| CAM  | Computer Aided Manufacturing      |
| CFD  | Computer Fluid Dynamics           |
| CHM  | Condition Health Monitoring       |
| CNC  | Computer Numerical Control        |
| CP   | Control Procedure                 |
| CS   | Certification Specification       |
| DOA  | Design Organization Approval      |
| EASA | European Aviation Safety Agency   |
| EBM  | Electron Beam Melting             |
| FEA  | Finite Element Analysis           |
| FPI  | Fluorescent Penetrant Inspection  |
| GM   | Guide Material                    |
| GP   | General Procedure                 |
| HIP  | Hot Isostatic Pressing            |
| HM   | Health Monitoring                 |
| HTP  | High Turbine Pressure             |
| IT   | Information Technology            |
| LBM  | Lattice Boltzmann Method          |
| LC   | Laser Cladding                    |
| LMD  | Laser Metal Deposition            |
| LRU  | Line Replaceable Unit             |
| MOA  | Maintenance Organization Approval |
| MRO  | Maintenance, Repair, and Overhaul |
| NDT  | Non-Destructive Testing           |
| OEM  | Original Equipment Manufacturing  |
| OI   | Operational Instructions          |
| PFM  | Phase-Field Models                |

|      |                                     |
|------|-------------------------------------|
| POA  | Production Organization Approval    |
| QA   | Quality Assurance                   |
| QC   | Quality Control                     |
| QMS  | Quality Management System           |
| QP   | Qualification Procedure             |
| RP   | Rapid Prototyping                   |
| SEM  | Scanning Electron Microscope        |
| SLM  | Selective Laser Melting             |
| SLS  | Selective Laser Sintering           |
| STC  | Supplemental Type of Certificate    |
| TC   | Type of Certificate                 |
| TEM  | Transmission Electron Microscopy    |
| WAAM | Wire and Arc Additive Manufacturing |



## **PUBLICATIONS**

Uriondo. A, Esperón. M and Perinpanayagam. S. The Present and Future of Additive Manufacturing in the Aerospace Sector – A Review of Important Aspects. Part G: Journal of Aerospace Engineering (*Accepted on 12/2014, online version*  
<http://pig.sagepub.com/content/early/2015/01/28/0954410014568797>)





# 1 INTRODUCTION

## 1.1 Background

This MSc by Research is funded by RepAIR, a 3-year EU-funded project that commenced in June 2013 under the auspices of the Seventh Framework Programme (FP7). The aim of RepAIR is to conduct research on future repair and maintenance technologies for the aerospace industry in order to maintain the competitiveness of the sector in Europe. RepAIR focuses attention on improving onsite maintenance and repair through such technologies as Additive Manufacturing (AM) for metals and Integrated Vehicle Health Management (IVHM).

The advantages of using AM are numerous: AM allows flexible availability of parts allowing on-time maintenance, such that there is no need to stock various parts. Only raw materials need to be stored and parts can be manufactured when required on-site.

RepAIR is mainly divided into four areas of research:

- Additive Manufacturing
- Health condition monitoring
- IT platform
- Certification

Universities from the United Kingdom (UK), Germany, and Denmark, along with companies interested in developing AM technology are focused on finding the benefits and limitations of AM, analysing various different AM techniques for metals, and demonstrate the feasibility of the technology.

The IVHM Centre participates in the development of new Qualification Procedures (QP) for two different AM technologies, as well as in the development of Quality Assurance, Quality Control and Quality Management procedures for these technologies, which deal with all aspects necessary for the certification of the technology and spare parts. These include specific procedures for the AM operations in repair or manufacture process, the

elaboration of a structure for a library of spare parts and build conditions compliant with the certification requirements, the integration of these procedures, workflows, register and designs in the IT platform (quality layer), and the pilot certification of a process (technology /material/condition) under the requirements of the newly developed concept

Universities and companies work together to check the feasibility of this process from a certification point of view, which is an important constraint of the aircraft industry that cannot be avoided.

The feedback of the industry is obtained from MROs (Maintenance, Repair and Overhaul) companies established in Europe and aircraft manufacturers.

The final objective is to demonstrate with a case study the feasibility and economic interest of the integration of Condition Health Monitoring (CHM) and the AM process into the MRO structure.

## **1.2 Requirements for manufacturing in the aerospace industry**

For aerospace, AM processes must be developed to meet the industry's stringent requirements and to ensure that products can achieve the robust performance levels established by traditional manufacturing methods, as well as, comply with the regulation framework [1-3].

Requirements for commercial aircrafts parts are mainly based on the regulations of the European Aviation Safety Agency (EASA) and regulations of the Federal Aviation Administration (FAA). These regulations are extensive and detailed, but the single most pertinent regulations in the context of AM can be found in CS-25, Book 1, Subpart D, Subsections CS 25.603 and CS 25.605 [4].

- **CS 25.603 Materials**

The suitability and durability of materials used for parts, the failure of which could adversely affect safety, must:

- a. be established on the basis of experience or tests;
- b. conform to approved specifications, that ensure their having the strength and other properties assumed in the design data (See AMC 25.603(b)); and

- c. take into account the effects of environmental conditions, such as temperature and humidity.
- CS 25.605 Fabrication methods
  - a. The methods of fabrication used must produce a consistently sound structure. If a fabrication process (such as gluing, spot welding, or heat treating) requires close control to reach this objective, the process must be performed under an approved process specification.
  - b. Each new aircraft fabrication method must be substantiated by a test programme.

Those brief but clear requirements have provided the impulse for implementing new fabrication methods. Every aerospace manufacturer has internal specifications that can support the accurate design of components from a given material, based on minimum performance and safety levels. Factors that must be considered for the material performance of even the simplest components include specific yield strengths, fatigue resistance, creep resistance, operational temperature, several tests of flammability, smoke release and toxicity, electric conductivity, multiple chemical sensitivities, radiation sensitivity, appearance, processing sustainability, and cost [5].

Despite increased rates of production, the aerospace industry must still produce many parts in very small quantities (the total aircraft deliveries from Airbus and Boeing in 2015 has been around 1000 units)<sup>1</sup>. AM processes, which can form almost finished parts with less intermediate tooling, thus eliminating the associated costs and delays, are extremely attractive to the industry.

### **1.3 Economics and operative advantages of AM for the aerospace industry**

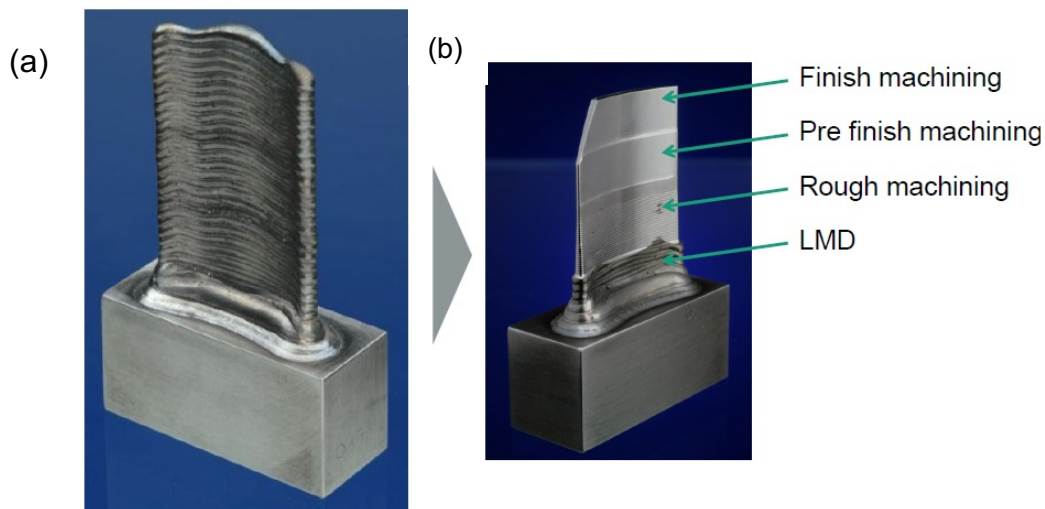
There is wide agreement on the potential applications of AM for repairing and manufacturing parts in the aerospace industry. There are many studies about the capability of this technology for designing parts in this industry [5-7];

---

<sup>1</sup> Information from [www.airbus.com](http://www.airbus.com) and [www.boeing.com](http://www.boeing.com)

repairing and manufacturing parts for turbo engines [2; 8]; in the spare part supply chain in MRO processes [1; 3]; amongst others.

The main characteristics that make this technology attractive for this industry include optimal raw material usage, reduced raw material stock size, fewer machine operations, reduced hard tooling requirements and reduced lead times when compared to other conventional manufacturing processes like forging, casting or machining. AM processes can manufacture parts close to the final geometry. This means that only the amount of material required to build up the parts is used, in contrast to other traditional processes (Figure 1-1). The buy-to-fly ratio is a measure of the material efficiency in terms of the amount of raw material needed to manufacture the final part. In contrast with traditional machining methods, which have buy-to-fly ratios between 5 and 20 [9; 10], AM can achieve values close to one [11]. Groneck [12] defines some advantages in terms of cost and cycle-time savings by switching from multi-piece built-up assembly to a single-piece.

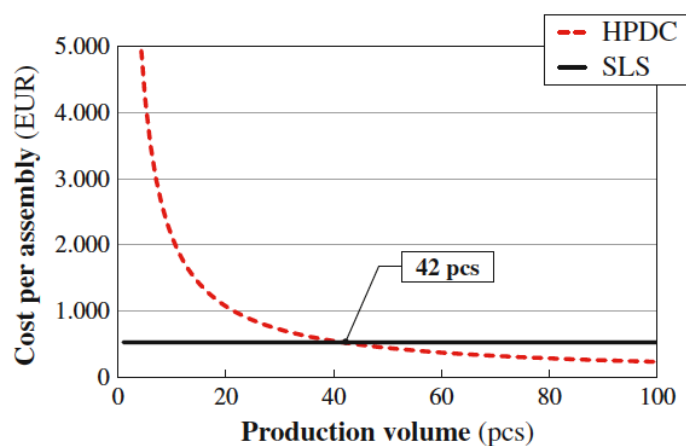


**Figure 1-1** (a) Near-shape process of AM permits reducing the raw material to produce a part. (b) Near-shape HPC blade. [8]

Other benefit of implementing AM in the repair or manufacture chain in the aerospace industry, is that it consumes less energy and emits less CO<sub>2</sub> than current manufacturing processes because, as suggested by Wood [13], using AM could reduce titanium ore extraction to 25% of the current amount

(extracting 1 kg of titanium from titanium ore produces 9 tons of CO<sub>2</sub>). Also, new supply chain configurations would reduce cost and produced CO<sub>2</sub> emissions. Khajavi et al., 2013 [1] have studied the impact of AM on the configuration of spare parts supply chains, using as a study case the spare parts supply chain of the F-18 Super Hornet fighter jet. They have studied four possible scenarios based on the supply chain configuration and the development of the AM technology. They concluded that, using the total operational cost (including downtime cost) as a reference to compare scenarios, the best supply chain configuration using the current AM technology would be centralized. However, when AM technology becomes more autonomous, less capital intensive and have shorter production time, the distributed configuration will be a better option [1].

Atzeni et al., 2012 [14] compare geometric possibilities and the cost in two different technologies for metal parts fabrication: High-Pressure Die-Casting (HPDC) and Selective Laser Sintering (SLS). Cost models of both processes are identified and applied to a case of study (landing gear of an P180 Avant II), concluding that AM technique can be economically convenient and competitive compared to traditional processes for small to medium batch production (Figure 1-2).



**Figure 1-2** Breakeven analysis performed by Atzeni et al., 2012 comparing HPDC and SLM processes. [14]

Finally, new free-form design approaches can be considered to implement new design tools, like topological optimization, in order to manufacture new complex and lightweight geometries or having new characteristics (like having a negative Poisson modulus [15]) that comply with all the technical requirements. Currently, there are many European projects, including FANTASIA [6], Karma [16], CoAMPIY [17], and Compolight [18] among others, working to implement AM in the aerospace industry.



(a) Centralized production (single manufacturing site)



(b) Distributed production (manufacturing capability at every service facility)

**Figure 1-3** Visual illustration of supply chain configuration. (a) Centralized, single manufacturing site. (b) Distributed, manufacturing capability at every service facility. [1]

## **1.4 Thesis outline**

The overall structure of this MSc by Research thesis takes the form of seven main chapters, including this chapter. Chapter 2 constitutes the literature review that has been carried out in order to have a description of the state of development of metal AM technologies where particular attention is given to Selective Laser Melting (SLM), Electron Beam Melting (EBM), and some Laser Metal Deposition (LMD) processes. Furthermore, a deeper research effort has focused on Ti and Ni alloys due to their importance in aerospace applications. Finally, the European regulatory framework for the aerospace industry as well as the necessary standards to develop new quality assurance and quality control procedures for these technologies have been reviewed and discussed.

A detailed description of the objectives and methodology used in this research is presented in Chapter 3. It is important to highlight the fact that in this project, all the certification analysis carried out has been useful to identify the rules and the possible ways to certify a manufactured or repaired AM part in the aerospace industry. However, this does not mean that a certification approval for the case studies will be issued by the Competent Authority. All the interactions with EASA in order to reach approval were not considered in the scope of the project.

The main outcomes of this work are reported in Chapters 4 and 5. In Chapter 4, a Qualification Procedure to ensure the repeatability of the manufacturing process is presented. Results of applying these procedures on two real case studies are also presented. Chapter 5 presents the new QA/QC procedures for EBM and SLM. All these procedures have been written in accordance with ISO 9001:2008, ISO 9000:2005, ISO EN 9100:2010, and EN 9110:2010. This includes not only general procedures and operative instructions, but also the control procedures to guarantee the quality manufacturing process.

All the outcomes of the research are discussed in Chapter 6 as well as the proposed future work.

## **2 LITERATURE REVIEW**

### **2.1 Introduction**

The purpose of this section is to review the state of the art in most extended AM technologies for metal parts, with particular emphasis on the relationship between material, process and metallurgical mechanisms. [19] A good knowledge of this field will help to develop new certification and Quality Assessment & Quality Management (QA/QM) processes for these technologies in the aerospace industry, one of the main objectives in the next few years. [20]

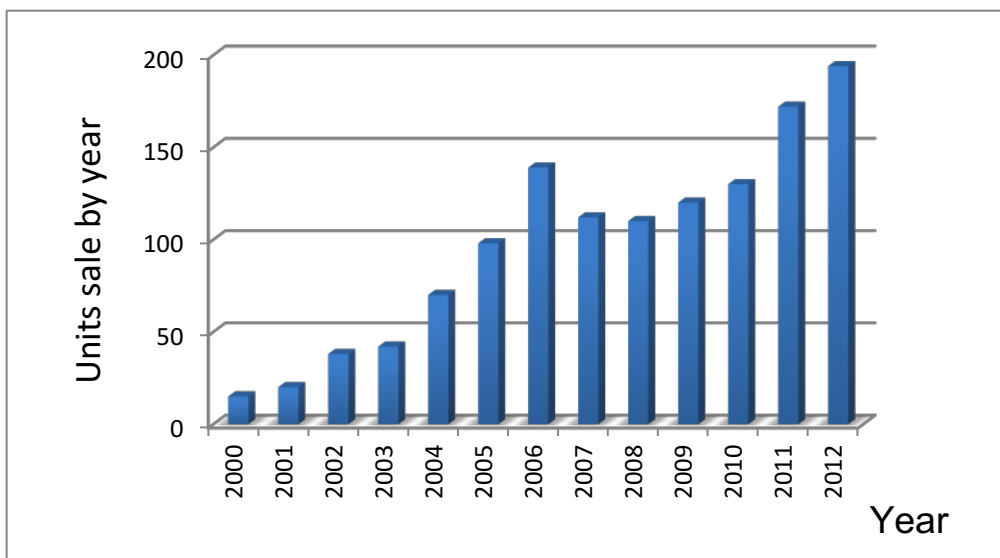
### **2.2 Additive manufacturing**

During the last few decades the manufacturing industry has developed new manufacturing techniques and technologies for low-volume production, innovative, customised, and sustainable products with a high level of complexity and technical requirements. One of these emerging technologies is AM. According to the ASTM Standard F2729-12a, AM can be defined as “the process of joining materials to make objects from 3D model data, usually layer upon layer, as opposed to subtractive manufacturing methodologies, such as traditional machining” [21]. For many years, this technology has been used to manufacture prototypes, but improvements in the accuracy of the process and materials properties have permitted some industries to build components that comply with the technical requirements for direct assembly proposes, such as air-cooling ducts for aircrafts [5] or hearing aids and prosthesis equipment (see graph represented in Figure 2-1) [22]. Rapid Prototyping (RP) is a synonym of AM that is common in the literature about AM. [7] Some authors, including Gibson et al., suggest that this term can be inadequate and does not describe the scope of this technology because it has been involved in testing, manufacturing, tooling and other activities outside of the “prototyping” definition. [23] The ASTM Standard F2729-12a defines RP as “additive manufacturing of a design, often iterative, for form, fit, or functional testing, or combination thereof”. [21] Other synonyms widely used for AM in the literature are Rapid



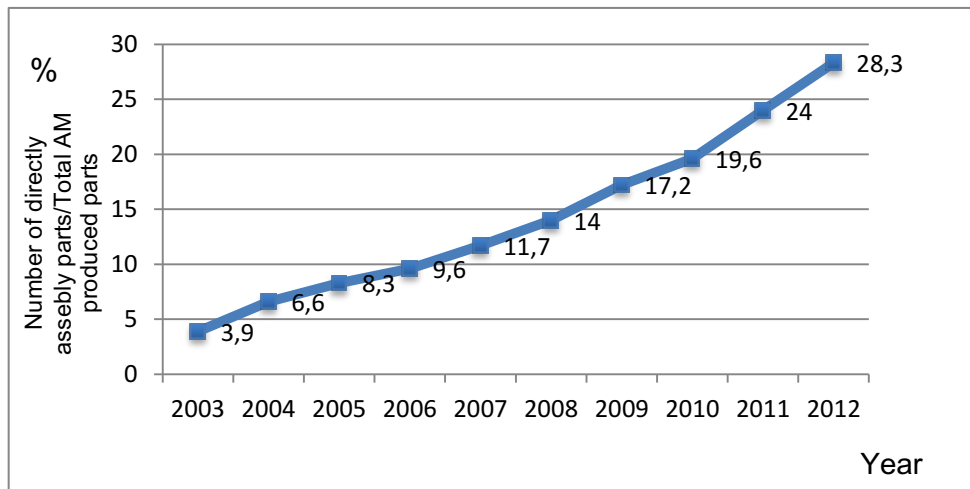
Manufacturing, [24] Additive Fabrication, Layer Manufacturing, Direct Digital Manufacturing, Free Form Fabrication, and Additive Techniques, among others.

Nowadays, many layered manufacturing techniques have been developed, such as photo-polymerisation (stereolithographic [23; 25] and its derivatives), ink-jet printing, fused deposition modelling, [26] Selective Laser Sintering (SLS,) [27] Selective Laser Melting (SLM), [28; 29] Electron Beam Melting (EBM), [30; 31] direct metal deposition, [32-34] amongst others. However, not all of them can produce metal parts. In this respect, Selective Laser Sintering (SLS), Selective Laser Melting (SLM), Laser Metal Deposition (LMD), Electron Beam Melting (EBM) and Wire and Arc Additive Manufacturing (WAAM) are presently the most versatile processes to produce complex functional metallic components (pure metals, alloys and metal matrix composites) to meet requirements from the aerospace, [5; 13; 35] defence [20] and biomedical industries. [36] Caffrey and Wohlers [37] have shown the increasing popularity of using this technology to produce metal components for industry by tracking metal-based AM machine sales by year. They recorded that approximately 20 units were sold in 2000 and close to 200 units in 2012 (see Figure 2-1). In their report, they also analyse how production of AM final parts has increased steadily over the last 10 years (see Figure 2-2).



**Figure 2-1** Units of AM machines for metal part sales by year. [37]

Levy et al. [22] consider that the competitive position of AM for metal components relative to other conventional manufacturing processes depends on the geometrical complexity and required production quantity.



**Figure 2-2** AM parts for direct assembly compared with total AM produced parts. [37]

Holmström et al. [38] suggest the following benefits of AM methods over conventional manufacturing methods.

- No tooling is needed, reducing production ramp up time and cost.
- Small production batches are feasible and economical. Possibility for quick design changes.

Product optimization for function (for example, optimised cooling channels). [5]

- The capability to produce complex geometries.
- Potential for simpler supply chains, shorter lead times, and lower inventories.

Fraizer [20] presented specific technical challenges in AM to enhancing operational readiness and energy efficiency, and reducing the total ownership cost of naval aircraft.

- Machine-to-machine variability must be understood and controlled. Industry specifications and standards for the processing of aerospace alloy components must be developed. To achieve this goal, he suggests

giving high priority to developing integrated processes, sensing monitoring, and control technologies.

- Alternatives to conventional qualification methods must be based upon validated models, probabilistic methods, and part similarities among others. New standards and advanced Non-Destructive Techniques (NDT) capable of detecting critical defects with a high degree of certainty are needed.
- New design guidelines with innovative structural characteristics are needed in order to reduce weight components.
- Physics-based models are needed in order to predict microstructure characteristics, mechanical and electrochemical properties. New alloys should be developed to optimize the process and the final properties. An understanding of how to achieve better fatigue properties and surface finish must be developed.

As has been mentioned before (see Section 1.3), the competitive position of AM for metal components relative to conventional manufacturing processes is due to the geometrical complexity and required material quantity. [22]

### **2.3 Classification of AM for metal components**

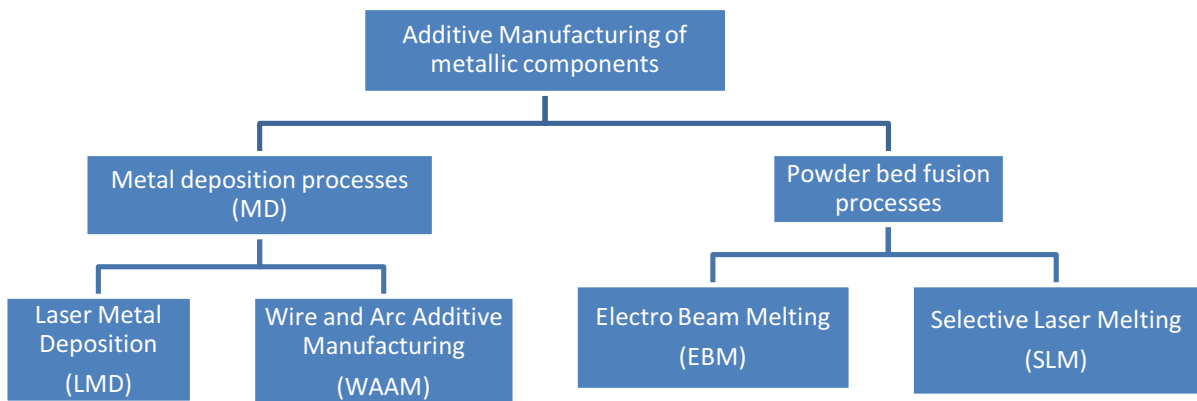
One of the most important steps in the development of AM has been the proliferation of this technology to produce metal components. Figure 2-2 shows the mean percentage of final AM parts for direct assembly in companies in which these technologies have been implemented. Although each AM technology has its particular characteristics in terms of usable material, processing procedures (Ultrasonic Consolidation process, from the company Solidica in U.S, is considered an AM technology that uses ultrasonic welding to join sheet metal laminates [39]), and capabilities. Nevertheless, most of them work using a point-wise method and use metal powder as a raw material. In this review, only SLM, EBM, LMD and WAAM are considered and described, because they are presently regarded as the AM processes most applicable to the aerospace industry. They can produce almost fully dense components (close to 99.9% density [29; 36; 40; 41]), and with limited post-processing, they

can achieve mechanical properties and other features comparable to other traditional methods.

There are many ways to classify these technologies. On the one hand, SLM and EBM are technologies that have the same set of characteristics: one or more thermal sources to melt the powder, a method to control each layer powder fusion area, and a mechanism to pre-spread a smooth powder layer. These types of technologies are referred as powder bed fusion processes.

On the other hand, unlike powder bed fusion processes, metal deposition processes melt the material as it is being deposited.

The source of energy to melt the powder depends on the process. Both SLM and LMD use a high power laser. By contrast, EBM uses an electron beam and WAAM a plasma arc. Figure 2-3 provides a schematic chart that classifies these technologies.

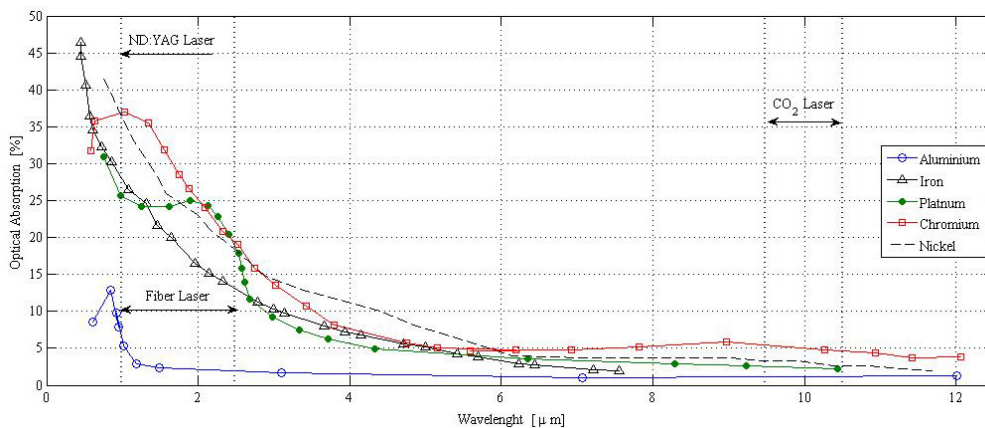


**Figure 2-3** Classification of AM processes based on different energy source and powder delivery system.

Selective Laser Sintering (SLS) is another important technology that was developed before LMD due to the continuously improved laser technology [42; 43] during the last few years including small focused spot, higher laser power and wavelengths better tuned to the absorptivity of metal powder (see Figure

2-4) [42; 44; 45]. Nowadays almost all AM machines use fibre lasers instead of CO<sub>2</sub> lasers or Nd:YAG because:

- they are easy to maintain;
- they are smaller system;
- they are more efficient in terms of energy, and
- they have a better beam quality.



**Figure 2-4** Optical Absorption (%) of selected metal vs wavelength. [23]

The following sections are a summary of the main characteristics of SLM, EBM, LMD and WAAM to understand how they work, and the different mechanism of beam energy-powder, deposition rate, processing conditions, material, and scan strategy, all of which affect the capability of each technology to obtain high performance metallic components.

Finally, it is important in to take into account that, due to the high interest in AM for metal components, various institutions and companies use different terminology for SLM, EBM, and LMD technologies (**Table 2-1**).

**Table 2-1** Different Terminology for SLM, EBM and LMD [36]

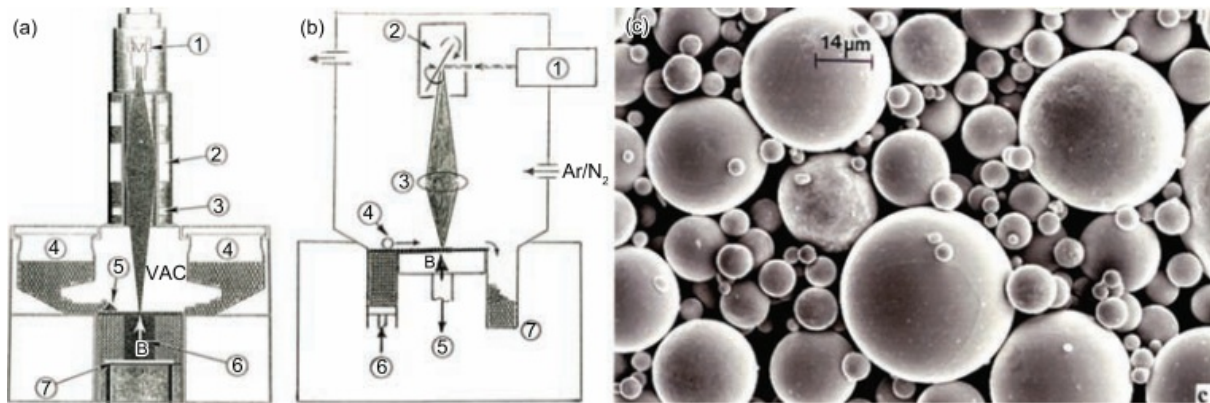
| Processes                     | Synonymous terms from institutions/companies   |
|-------------------------------|--|
| Selective Laser Melting (SLM) | <i>Direct metal laser sintering</i> (EOS GmbH, Germany)<br><i>Direct metal laser re-melting</i> (University of Liverpool, U.K)<br><i>Lasercusing</i> (Sauer Product GmbH, Germany) |
| Laser metal                   | <i>Direct Metal Deposition</i> (The University of Michigan, U.S.)  |

|                             |  |
|-----------------------------|--|
| Deposition (LMD)            | <i>Laser engineered net shaping</i> (Sandia National Laboratory, U.S.)<br><i>Directed light fabrication</i> (Los Alamos, U.S.)<br><i>Direct laser deposition</i> (University of Manchester, U.K.)<br><i>Direct laser fabrication</i> (University of Birmingham, U.K.)<br><i>Laser rapid forming</i> (North-western Polytechnical University and The Hong Kong Polytechnic University, China).<br><i>Laser melting deposition</i> (Beihang University, China) |
| Electron Beam Melting (EBM) | <i>Electron Beam Melting</i> (Arcam, Sweden)   |

### 2.3.1 Electron Beam Melting

EBM uses a high-energy electron beam to heat and melt the metal powder (c). This process uses the same principles of electron welding. [46] This process was developed at Chalmers University of Technology in Sweden, and was previously commercialized by Arcam AB. [47] Following the numbers in the Figure 2-5(a), the electron beam is generated and then accelerated in a heated filament (1) with a voltage difference of approximately 60 kV [23; 48]. This system is more efficient than a laser beam generator, because most of the energy is converted into the electron beam. This means that higher beam energies are available with lower cost.

Electrons in the beam move close to the speed of light (around 70% [48]) and, as in electron beam welding, the process has to be carried out in a vacuum, so that electrons from the beam will not interact with the atoms of the atmosphere and will be reflected.



**Figure 2-5** (a) EBM and (b) SLM systems schematics. (c) Atomized Cu powder (Scanning Electron Microscope, SEM image).

Following Figure 2-5(a), powder is normally gravity-fed from the cassettes (4) and distributed (5) onto the built table (7). The electron beam is focused with a focus coiling (2) in order to achieve the correct spot diameter and electromagnetically-positioned (3) with deflection coils that control x-y motion. The building direction (z axis) is denoted by the arrow (B).

### 2.3.2 Selective Laser Melting

SLM (see Figure 2-5(b)) uses a high energy laser beam (1) to heat and melt the metal powder (layers ~0.1 mm thick [23]) which has been raked across the build area (5) using a counter-rotating powder levelling roller (4). Powder is fed from a container (6). The powder that has not been used can be recycled (7). After finishing a layer, the build platform is lowered by one layer thickness and a new powder bed is spread. The building process takes place in a protected atmosphere (normally argon or nitrogen gas) to minimize the oxidation and degradation of the material during the process. This technology uses galvanometers (2) (mirrors) to move the laser spot from one zone to another. As in the schematic of the EBM process, the building direction (z axis) is denoted by the arrow (B).

### 2.3.3 Comparison between SLM and EBM

Both systems create a powder bed by raking or rolling powder from cassettes into a compacted layer. In each layer the laser or the electron beam melts the

metal powder depending on the technology. After that, the melted powder is rapidly solidified thanks to the inert atmosphere (SLM) or vacuum (EBM). EBM uses magnetic coils which have an almost instantaneous response because they can be moved almost from one zone to another without crossing the area in between. Moreover, mirrors of SLM have certain inertia and are attached to motors, meaning that the scanning speed of SLM depends on the mass of the mirrors and the distance from the mirrors to the powder bed and it is always going to be much lower than the magnetics coils of EBM.

The inherent characteristics of the heat source in each process also affect the material being processed. While in SLM the energy of the photons is absorbed by the powder particles, in EBM the electrons transfer their kinetic energy to the powder particles. This means that powder particles increase their negative charge. If the conductivity of the raw material is not high enough to avoid the highly-negative charge, two adverse effects could occur [23]:

- If the order of magnitude of the repulsive force is around or superior to the order of magnitude of the gravitational and frictional forces, there will be an expulsion of powder particles from the powder bed, creating a powder cloud.
- The electronegativity of the powder bed will create a more diffuse beam due to the tendency of the charged powder to repel the incoming electrons.

Those problems are not present in SLM. To avoid these negative effects in EBM the conductivity of the raw material must be high. This means that EBM can only process materials like metals, whereas SLM can process any material that absorbs energy from a laser wavelength (e.g. metals, polymers or ceramics).

Another important issue is energy cost. In EBM, most of the energy applied to the heated filament to generate the beam is converted into the kinetic energy of electrons, but in SLM only 10-20% of the total energy input is converted into the laser beam with the rest lost in the form of heat [23]. However, newer laser

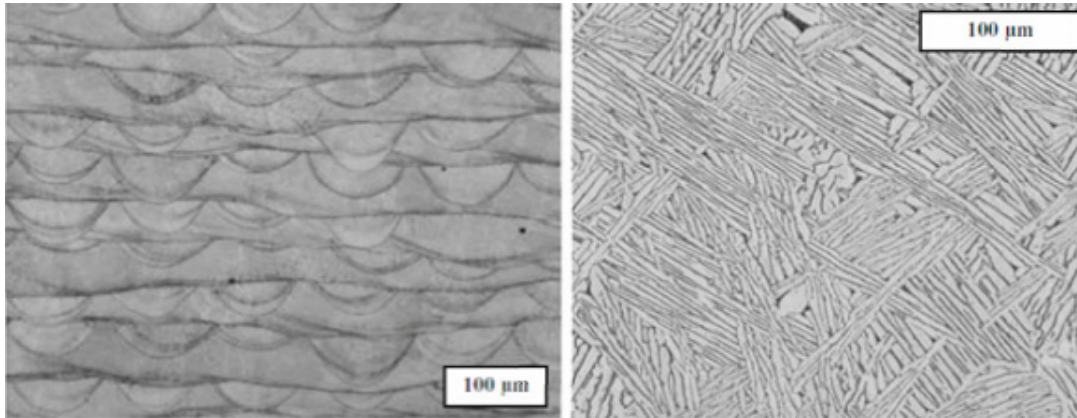


technologies (fibre lasers) are simpler in their design, more reliable, and have better energy conversion efficiency (around 70-80% for some cases) than conventional technologies. [23; 42] Therefore this might not be a major advantage of EBM over SLM.

In both EBM and SLM, the powder bed is maintained at an elevated temperature. Pre-heating the powder is necessary to minimize the laser/electron beam power requirements and to prevent the part from warping due to the high thermal gradient (curling). However, there is a difference between both heating mechanisms and the operating temperatures of both processes:

- SLM: Infrared heaters placed above the build chamber attempt to maintain the temperature of the powder bed around 90°C [49]. In some cases, there is also a resistor around the build platform to maintain this temperature.
- EBM: The total surface area is heated uniformly to a pre-set temperature by the electron beam (defocused).

As a result, the microstructure of the part changes significantly from EBM to SLM. Normally in SLM the individual scan lines are distinguishable (see Figure 2-6). [31; 50; 51] Furthermore, the inert atmosphere present in SLM processes in the build chamber favours heat conduction. The cooling rate of the melted pool makes the SLM technology creates a smaller grain size. The powder bed is held at a low temperature and sometimes grain growth does not eliminate the layering effect (see Figure 2-6). However, in EBM the higher temperature of the powder bed (close to the fusion temperature of the metal or the alloy), allows for mass diffusion between layers and creates almost an isotropic microstructure that is more representative of other traditional processes, like casting, with less porosity than SLM processes.



**Figure 2-6** Representative CoCrMo SLM microstructure (*left*, courtesy EOS), and Ti6Al4V EBM microstructure (*right*, courtesy Arcam AB). [23]

**Table 2-2** Differences between EBM and SLM. [23]

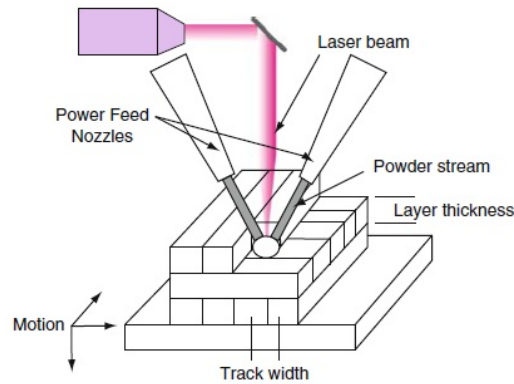
| <b>Characteristic</b>     | <b>EBM</b>           | <b>SLM</b>                      |
|---------------------------|----------------------|---------------------------------|
| <b>Thermal source</b>     | Electron beam        | Laser                           |
| <b>Atmosphere</b>         | Vacuum               | Inert gas                       |
| <b>Scanning</b>           | Deflection coils     | Galvanometers                   |
| <b>Energy absorption</b>  | Conductivity-limited | Absorptivity-limited            |
| <b>Powder pre-heating</b> | Use electron beam    | Use infrared heaters            |
| <b>Scan speed</b>         | Very fast            | Limited by the mirror's inertia |
| <b>Energy cost</b>        | Moderate             | High                            |
| <b>Surface finish</b>     | Moderate to poor     | Excellent to moderate           |
| <b>Feature resolution</b> | Moderate             | Excellent                       |
| <b>Materials</b>          | Metals <sup>2</sup>  | Polymers, metals and ceramics   |

### 2.3.4 Laser Metal Deposition

LMD is the term used to refer to all processes that are able to build parts by melting and deposition metallic material from powder or wire feedstock. Unlike powder bed fusion techniques, in LMD the raw material is melted as it is being deposited. However, there are similar processes that use an electron beam or a plasma source instead of a laser beam as a heat source [33; 52-54]. The

<sup>2</sup> Only with conductive materials

deposition head is usually an integrated collection of laser optics, powder nozzle(s), and inert gas (see Figure 2-7).

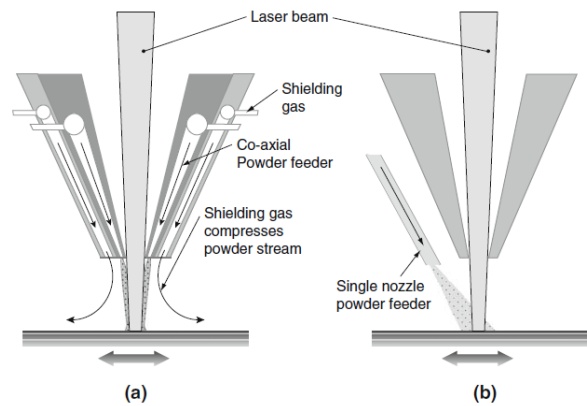


**Figure 2-7** Schematic of a typical beam deposition process. [23]

The deposition is controlled by relative motion between the substrate (it can be a new part or a part onto which additional geometry will be added) and the deposition head. In order to achieve more complex geometries, 4 or 5-axis systems with rotary tables or robotic arms are available. LMD can utilize both powder and wire feedstock as raw material. On the one hand, the capture of powder feeding is not completely efficient (not all powder is captured in the melt pool), but it is more versatile in terms of materials. On the other hand, wire feeding can achieve 100 % capture efficiency and, with a good control of geometry-related parameters (hatch width, layer thickness, wire diameter and wire feed rate) and additional machining process (such as CNC), it can produce complex, large and fully dense parts. However, the porosity at the surface can be high.

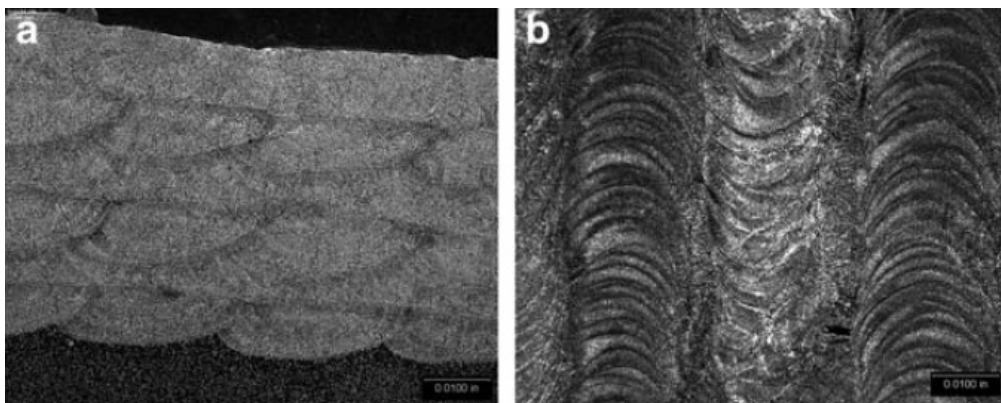
Powder is focused at the melting pool using either co-axial feeding [55], 4-nozzle feeding or single nozzle feeding. The co-axial nozzle (see Figure 2-8(a)) is designed to maximize the capture efficiency of the powder as well as to protect the melt pool from oxidation. However, its cost is higher than single-nozzle feeding (Figure 2-8(b)), which is not only simpler and cheaper, but also has the ability to deposit material into tight locations, for example inside a small conduit. Finally, the 4-nozzle feeding involves 4 nozzles separated 90 degrees

around the laser beam, and makes it easier to control the thickness of the track during the process compared to other nozzles.



**Figure 2-8** (a) Co-axial nozzle feeding and (b) single-nozzle feeding. [23]

Because these processes all involve deposition, melting, and solidification of raw material using a moving melt pool, the final parts achieve an elevated density during the build process (the porosity usually appears next to the surface of the part due to adhered partially molten particles). The typical microstructure attained is similar to the SLM process wherein each scan line creates a track of rapidly solidified material (compare Figure 2-6 and Figure 2-9).



**Figure 2-9** CoCrMo deposit on CoCrMo: (a) side view and (b) top view of deposit. [23]

LMD is a technology that is sold as a flexible platform owing to its capabilities. It can coat, build and rebuild components with complex geometries and larger volume than powder bed fusion processes. This means that the users of this technology have to identify the correct process parameters for their material,

geometry and application. Parameters, such as track scan spacing, powder feed rate, laser traverse speed, laser powder and spot size among others, are interrelated (e.g. increasing the feed rate can have the same effect as lowering the laser power). Scan strategy is also very important in part quality. Changing the scan orientation from layer to layer can minimize the residual stress and the correspondent distortion. [56-58]

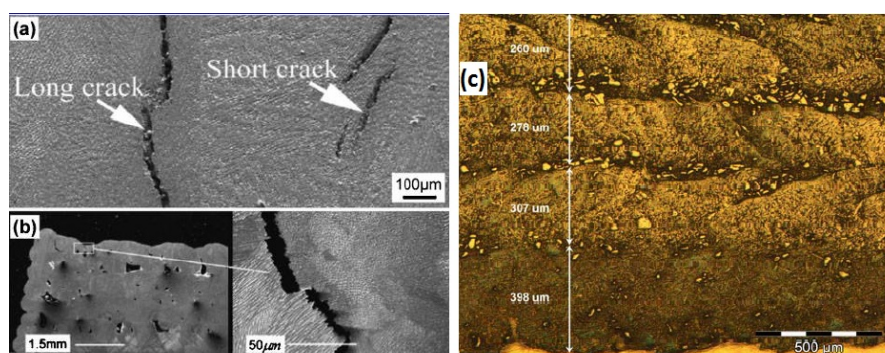
Layer thickness setting must be lower than the melt pool depth in order to produce a fully dense product.

As has been mentioned above, the cooling rates could be extremely high (from  $10^3$  to  $10^4$  C/s [59; 60]) creating a microstructure with several advantages. [23]

- Suppression of diffusion controlled solid-state phase transformations
- Formation of supersaturate solutions and no equilibrium phases
- Formation of extremely fine microstructures with non-segregation
- Formation of precipitates, inclusions, carbides, etc.

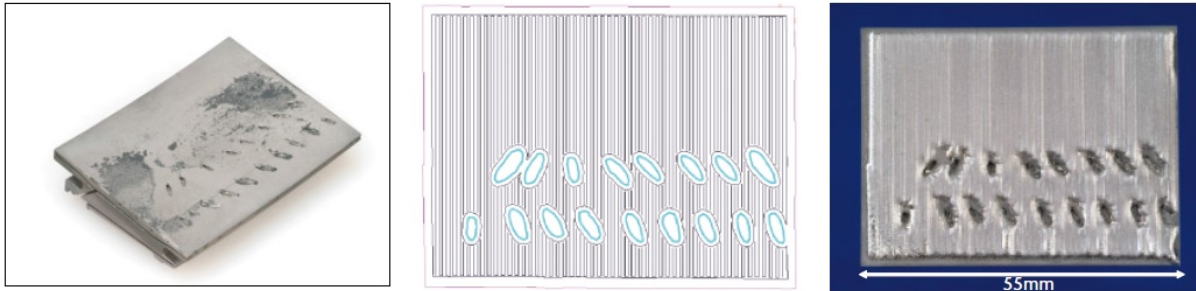
However, this is the source of one of the most significant problems in LMD processes. Residual stresses are generated as a result of this solidification, which can lead to cracking during or after part construction (see Figure 2-10(a)).

In general, parts produced using LMD exhibit superior yield and tensile strengths and a lower ductility due to their fine grain structure. The ductility of the alloy and microstructure can be modified with post-thermal treatment.



**Figure 2-10** Cracks formation in (a) LMD-processed Rene 88DT and (b) SLM processed Waspaloy. (c) LENS-deposited Ti/TiC (4 layers on top of a Ti substrate).[23]

This technology can also be used to repair components which are considered to be non-repairable by conventional methods. [61] Results from various studies [6; 8], have demonstrated the potential of this technology for repair of high-value turbo-engine components.



**Figure 2-11** (a) CFM-56 HTP Shroud before LMD processing, (b) filling strategy and (c) LMD-processed shroud. [8]

## 2.4 Aerospace alloys in AM processes

There are various alloys suitable for AM technologies. A majority of research efforts have focused on Ti, Ni and Fe-based alloys. Only Ti and Ni based alloys are reviewed and discussed here due to their importance in aerospace applications. Table 2-3 summarizes some of the main characteristics of those alloys.

**Table 2-3** Alloys for various AM processes.

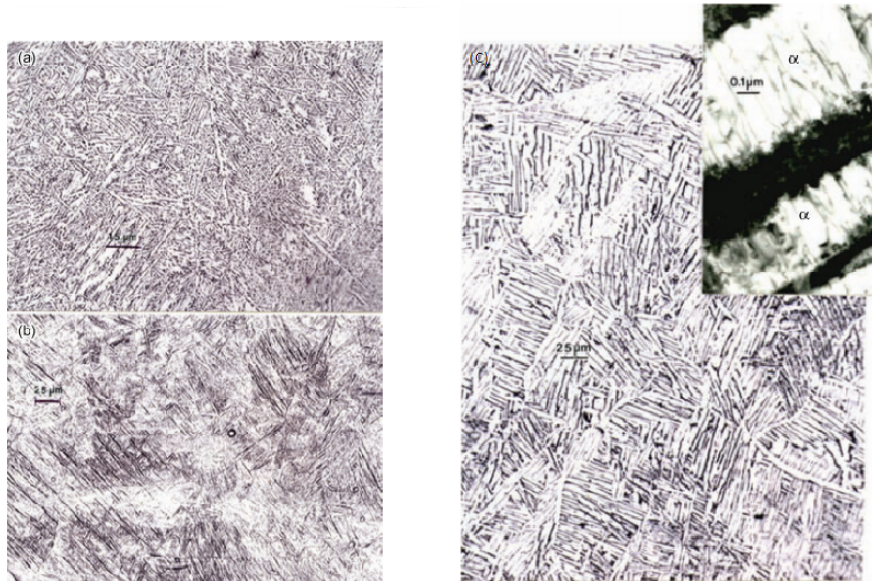
| Based element | Alloy       | Powder characteristics                                       | Ref  |
|---------------|-------------|--|------|
| Ti            | Ti6Al4V     | Particle size 25-45 $\mu\text{m}$                            | [36] |
|               | Ti6Al4V ELI | Particle size 25-45 $\mu\text{m}$                            | [36] |
| Ni            | Inconel 625 | Spherical shape (95%);<br>particle size 20-135 $\mu\text{m}$ | [36] |
|               | Waspaloy    | Average particle size 63 $\mu\text{m}$                       | [36] |
|               | Inconel 718 | Particle size 44-150 $\mu\text{m}$                           | [36] |



|           |                                    |      |
|-----------|------------------------------------|------|
| Rene 88DT | Particle size 44-150 $\mu\text{m}$ | [36] |
| HallstoyX | Particles size 20 $\mu\text{m}$    | [62] |

### 2.4.1 Titanium alloys

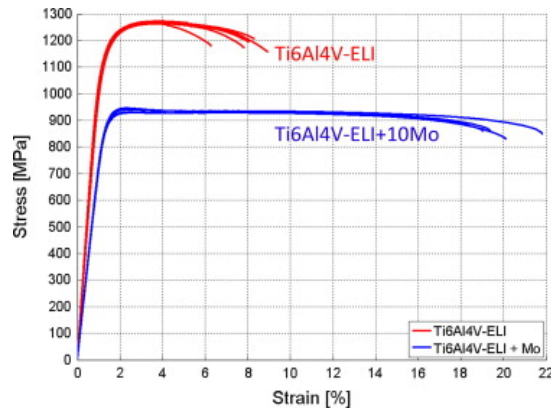
Facchini et al. [63; 64] have studied how to modify the mechanical properties of Ti6Al4V used to produce parts with heat treatments. They improved the ductility of the material by modifying the metastable martensite into a biphasic  $\alpha$ -phase acicular microstructure. This suggests how to control the martensite transformation of Ti6Al4V alloy through the variation of the parameters of AM machines. Since the cooling rate is higher for SLM than EBM, the resultant microstructure of Ti6Al4V components differs from dominant martensite to fine  $\alpha$ -phase structure respectively. This means that the hardness and the ductility will be different for both processes. Murr et al. [49] studied microstructure differences for Ti6Al4V, concluding that the hardness in SLM (41 HRC) is higher than in EBM (32 HRC) for Ti6Al4V components. They did not observe any main directional grain growth for either process. However, Thijs et al. [41] have concluded that for SLM processes the orientation of the grains is highly dependent on the scan velocity and scan strategy, the latter being a powerful tool to control the grain orientation. The analysis of Transmission Electron Microscopy (TEM) images from Murr et al. [49; 65] studies shows high dislocation density inside  $\alpha$ -phase grains in EBM processes and deformation twins in  $\alpha$ -phase in the martensitic structure (see Figure 2-12). This deformation behaviour is the consequence of the rapid cooling rate of both processes, and indicates a high level of induced thermal residual stresses. Also, due to the high cooling rate and high conductive heat transfer rate in both processes, only a small volume of precipitates ( $\text{Ti}_3\text{Al}$ ) will be formed. Thijs et al. [41] observed in their studies that if more material remains for a longer time at higher temperatures, the volume of precipitates will increase and thus the micro-hardness will be higher. To achieve this goal, they propose two alternatives: lowering the hatch spacing or the scanning velocity.



**Figure 2-12** (a) Ti6Al4V fabricated by EBM. (b) Ti6Al4V fabricated by SLM. (c) The TEM image for EBM-fabricated Ti6Al4V shows high dislocation density in  $\alpha$ -phase. [49]

Vrancken et al. [66] studied the influence of mixing Ti6Al4V ELI powder with 10 wt.% Mo powder. The mixed powder was processed by an SLM machine (LM-Q machine of the PMA Division of the Department of Mechanical Engineering, KU Leuven). The resulting microstructure consists of homogeneously-dispersed Mo particles in  $\beta$ -phase matrix with a  $\langle 100 \rangle$  cube texture in the building direction. It presents high strength ( $\sigma_{0.2}=858$  MPa) and excellent ductility ( $A=21$ ). Figure 2-13 shows their tensile test results. All the static tensile tests were performed following the recommendation of ASTM standards for additive manufacturing (ASTM E 8M for the tensile test, ASTM E11 to determinate the Yield stress and Young's modulus, and specimen dimensions of ASTM Standard E23). Table 2-4 summarizes the mechanical properties of EBM Ti6Al4V specimens.





**Figure 2-13** Engineering stress-strain curves for Ti6Al4V and Ti6Al4V10Mo produced by SLM. [66]

**Table 2-4** Static mechanical properties of Ti6Al4V without any post-process in the build direction.

| Process | YS (GPa) | UTS (GPa) | % Elongation | Ref               |
|---------|----------|-----------|--------------|-------------------|
| EBM     | 1.1-1.15 | 1.15-1.2  | 16-25        | [31]              |
|         | 0.83     | 0.915     | -            | [64]              |
|         | 0.735    | 0.775     | 2.3          | [67]              |
| SLM     | 0.865    | 0.972     | 10           | SLM Solution GmbH |
|         | 1.07     | 1.2       | 11           | EOS GmbH          |
|         | 0.835    | 0.915     | 10.6         | [63]              |
|         | 0.99     | 1.095     | 8.1          | [63]              |
| WAAM    | 803      | 918       | -            | [58]              |

### 2.4.2 Nickel-based alloys

Nickel-based alloys are used for high performance components in the aerospace industry due to their tensile properties, high damage tolerance, ability to creep at high temperature and corrosion/oxidation resistance. [68] Those alloys are strengthened by precipitates. However, AM processes result in a high cracking tendency due to the amount of elements in the intermetallic

phases. With these alloys, it is difficult to eliminate these short cracks merely by adjusting the process parameters in the machine. Hot Isostatic Pressing (HIP) procedures are required to improve the mechanical properties. Static mechanical properties of Inconel 625 processed by EBM are described in Table 2-5 [40]. HIP conditions applied were 1393 K, 100 MPa during 4 hours. Before HIP, the microstructure was characterized by columnar grains (up to 20  $\mu\text{m}$ ). Subsequently, the columnar grains recrystallized, and the metastable  $\gamma''$ -phase ( $\text{Ni}_3\text{Nb}$ ) dissolved. Murr et al. [40], suggest the modification of microstructure in different directions by modifying manufacturing-process parameters.

**Table 2-5** Static mechanical properties of IN645 achieved by EBM. [40]

| <b>Process</b> | <b>Yield strength,<br/>MPa</b> | <b>Tensile strength,<br/>MPa</b> | <b>% Elongation</b> |
|----------------|--------------------------------|----------------------------------|---------------------|
| EBM            | 410                            | 750                              | 44                  |
| EBM + HIP      | 330                            | 770                              | 69                  |

Strondl et al. [69] have studied the microstructure and phase evolution of Inconel 718 with EBM (ARCAM™) without any post-process (like HIP). They obtained a matrix consisted of  $\gamma$ -phase grains oriented in almost the same direction, like single crystals. The precipitates are aligned in the growth direction too. Mechanical properties of this alloy in various AM technologies are reported in Table 2-6.

**Table 2-6** Static mechanical properties of IN718 for SLM and EBM. [70]

| <b>AM Process</b> | <b>UTS, MPa</b> | <b>YS, MPa</b> | <b>% Elongation</b> |
|-------------------|-----------------|----------------|---------------------|
| EBM               | 910             | 580            | 22                  |
| SLM               | 904             | 552            | 16                  |

### 2.4.3 Fatigue, porosity and roughness

Roughness and porosity are the main factors that affect fatigue behaviour directly. It is very important to identify the influence of both parameters in this failure mechanism. Koike et al. [67] investigated the effect of roughness on

fatigue life in Ti6Al4V parts fabricated by EBM and SLM. They conclude that the fatigue life of SLM parts is higher than EBM. They correlated the fatigue life in cycles with the surface finish, concluding that a high level of roughness results in a shorter fatigue life. Greitmeir et al. [71] showed that surface defects had the most pronounced impact on reducing high cycle fatigue life.

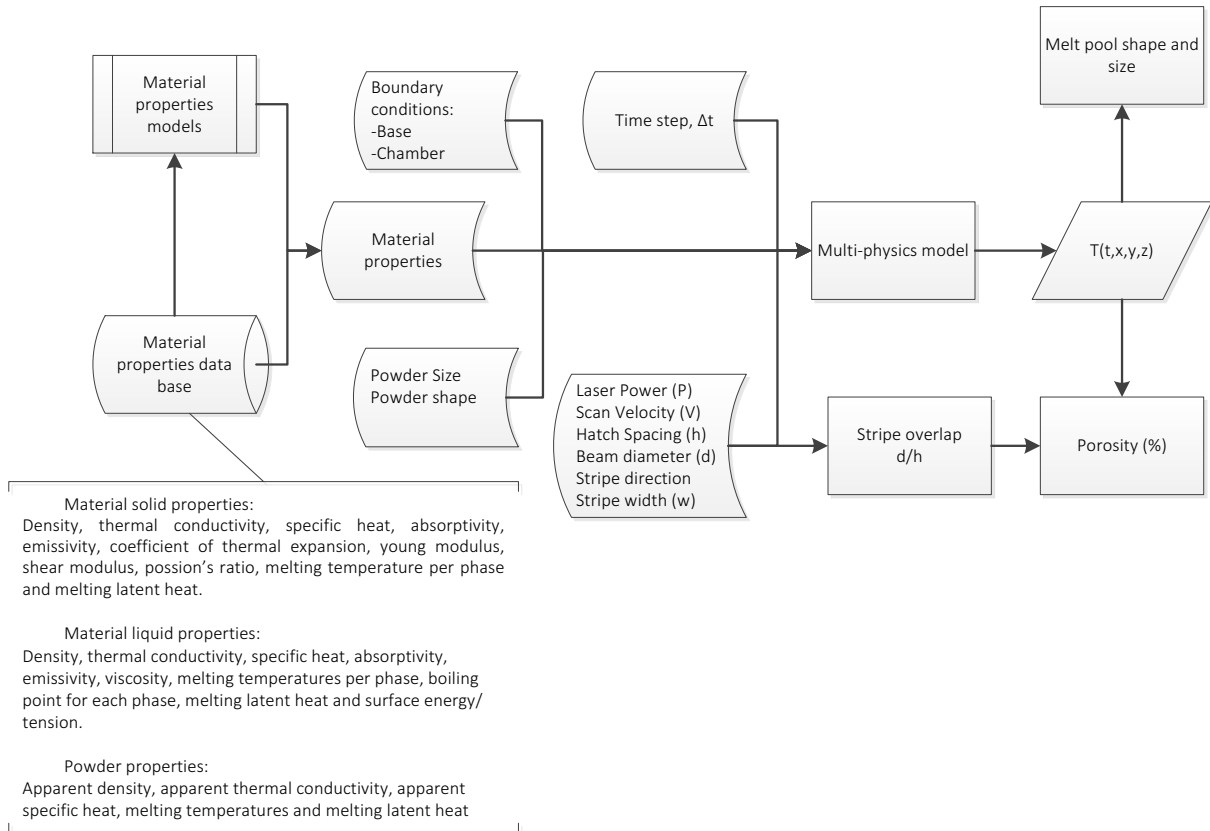
Surface roughness depends on the technology, the scan strategy, the position of the part on the build platform, and some other process parameters, like the hatch space or the scan velocity. [41; 70] Mazumuder et al. showed that for laser cladding, a type of LMD processes, the largest roughness can be measured perpendicular to the clad direction on the top surface (5% greater than in the parallel direction) and in the vertical direction on the walls (3% greater than in the horizontal direction). [72]

## **2.5 Modelling AM processes**

Certifying AM parts for aerospace applications requires a better control of the machines, as well as good process-microstructural models to predict the final properties of each part. [7; 20] This can be monitored via process variables, such as laser power, scan velocity, preheating temperatures and scan strategy among other (see scheme in Figure 2-14). Experience in welding processes and others manufacturing methods has demonstrated that both the temperature distribution as well as the temperature history have an influence on the distortion induced by residual stresses, microstructure and consequently, on fatigue behaviour. Thus, much research related to the analysis of temperature distribution in transient heat conduction for welding [73] has been applied to modelling AM processes. [74] However, none of this research takes into account all physical phenomena during the process, like non-thermal constant properties, heat of phase transformation, natural-convection in the liquid pool, latent heat of fusion, vaporization, and solidification amongst others. Neglecting these effects can result in important differences between the model and actual performance. For instance, Negi et al. [75] showed with a FEA analysis that taking into account the effect of non-constant thermal material properties as well as the effect of radiation and convection heat, predict a good temperature

distribution compared to the experimental case. Zhang et al. [76] showed that neglecting melting and re-solidification processes, and thus the density change, could result in important errors in the thermal model.

The need to maintain proper build conditions and to limit residual stresses is coupled with the desire to control part microstructure. Process maps for each alloy and AM process have been developed to understand the relationship between process variables (laser power, scan velocity, preheating temperatures, part geometry, etc.) and relevant cooling rates to obtain desirable microstructural features. [74] These process maps are developed using non-linear thermo-mechanical finite element simulation and different testing samples. They are named “process maps” because they can provide a set of key parameters to obtain desirables features like specific mechanical properties, microstructure, or porosity level, amongst others.



**Figure 2-14** Detailed model map for AM processes.

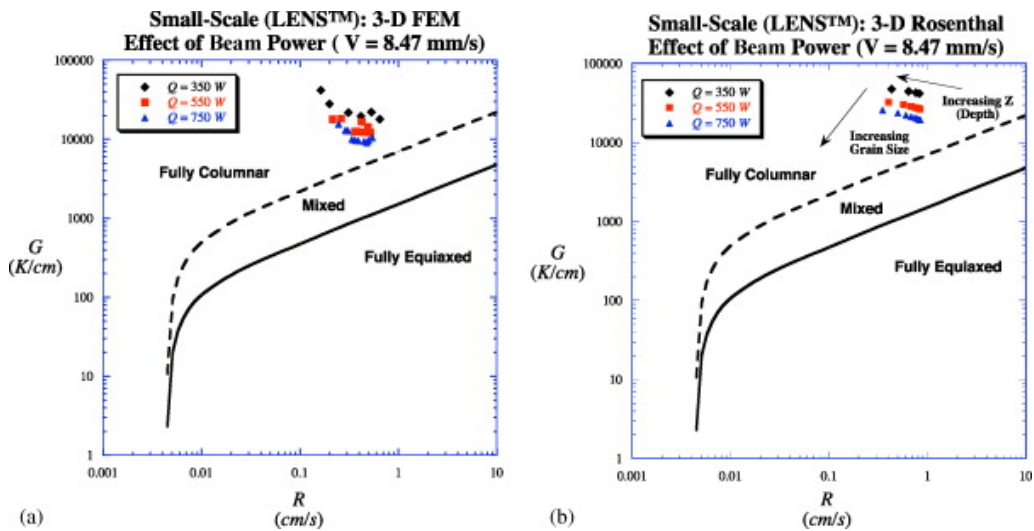
### 2.5.1 Selective Laser Melting models

SLM is a complex process with multiple physical phenomena. The laser beam interacts with the material, which at the beginning is powder, but then melts to become liquid. Heat transfer depends on the conductivity and it changes from powder to dense parts, both of them being part of the interface with the molten pool; gravity forces and temperature gradients in the pool produce natural and Marangoni convections. A good understanding of the above-mentioned phenomena will allow the control of produced parts properties, such as microstructure, porosity and residual stresses.

Verhaeghe et al. [77] developed a model to study the influence of evaporation phenomena during the process. They conclude that for high energy density inputs, evaporation occurs and its effect on the temperature-pool profile cannot be neglected. Additionally, the depth of the pool taking into account the evaporation phenomena is lower in the model. This is due to part of the input

energy being used for liquid-gas phase change. However, the size and shape of the cross-section do not agree with the experimental data. Including the Marangoni convection phenomena in the model could help to improve the model and reproduce a more realistic melt pool width and depth.

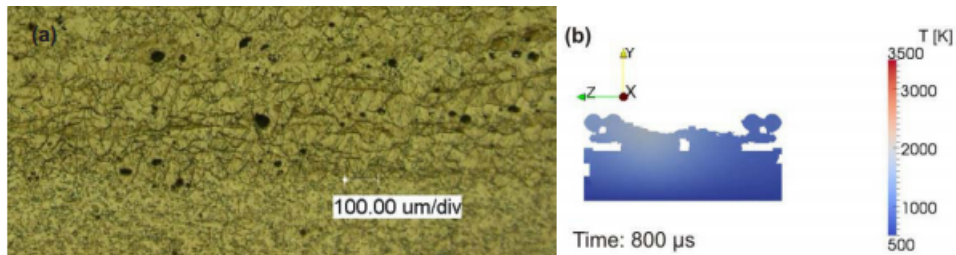
Kobryn et al. [26] have studied how power or the scan velocity process variables could affect the final microstructure of Ti6Al4V during laser processes like LMD or SLM. In their studies, they first an analytical model based on the Rosenthal solution. [78] This first approach does not take into account the nonlinear effects of temperature-dependent properties and the latent heat of the alloy. However, it shows the order of magnitude of some process variables in thin-wall and bulky structures. These results have been compared with a numerical model based on a FEA model in order to study the influence of neglected phenomenon. They conclude that the Rosenthal results for both situations, thin-wall and bulky structures, are consistent with those obtained from the numerical model (FEA) with laser power (between 350-750 W [26]) (see Figure 2-15).



**Figure 2-15** Predicted Ti-6Al-4V grain morphology for low laser power (LENS) of Bulky 3-D from (a) 3-D Rosenthal Solution and (b) 3-D FEM.<sup>3</sup> [26]

<sup>3</sup> Given the solidification cooling rate  $\frac{\partial T}{\partial t}$  and the thermal gradient  $G = |\nabla T|$ , the solidification velocity  $R$  is determined as  $R = \frac{1}{G} \frac{\partial T}{\partial t}$

Gürtler et al. [79] used the three-dimensional volume fluid method to study the effect of the powder-layer thickness, power, scan spacing and scan velocity on the process dynamics. In their model, they used part of the Otto and Schmidt models for laser material processing. [43] Realistic results for process dynamics and defects were achieved by using the parameters of industrial machines (Renishaw™ AM125).



**Figure 2-16** Comparison of porosity in experiment and simulation. [79]

Models from other technologies close to SLM (like SLS) can be used to understand the influence of other parameters, like the number of layers underneath. Chen and Zhang [80] concluded that the dimensionless intensity of the moving heat source in SLS processes to achieve the desired sintering depth and to bond the newly-sintered layer to the previously-sintered ones increases with the scan velocity.

Xiao and Zhang [81] have also studied the influence of existing sintered layers in the process, but include Marangoni and natural convections in the model. The computer code was validated by comparing the predicted cross-section for the liquid/solid interface during laser melting of a non-porous 6063 aluminium sheet with experimental results. They conclude that the fluid flow has a significant influence on the temperature field, and thus on the shape of the melt pool. Also, if the number of existing sintered layers underneath is increased, higher energy density is needed to achieve the required overlap between the layers and avoid the negative “lack of fusion” phenomena.

Several experiments have indicated that if the scan velocity falls outside of a specific interval, tracks become broken. This undesirable instability in the pool during the process is known in the literature as the “balling” effect. These

phenomena can be explained by the Plateau-Rayleigh capillary instability for high scan velocities. Gusarov et al. [82], neglecting melt flow, and thus the Marangoni convection, created a physical model taking into account radiation and heat transfer to study this “balling” effect for high scan velocities. They conclude that this simple model can be used to estimate the contact between the melted material and the layer underneath, one of the factors that helps to avoid this problem. Zhou et al. [45] suggest packing different types of metal powders with different melting points and different emissivity to avoid the “balling” phenomenon.

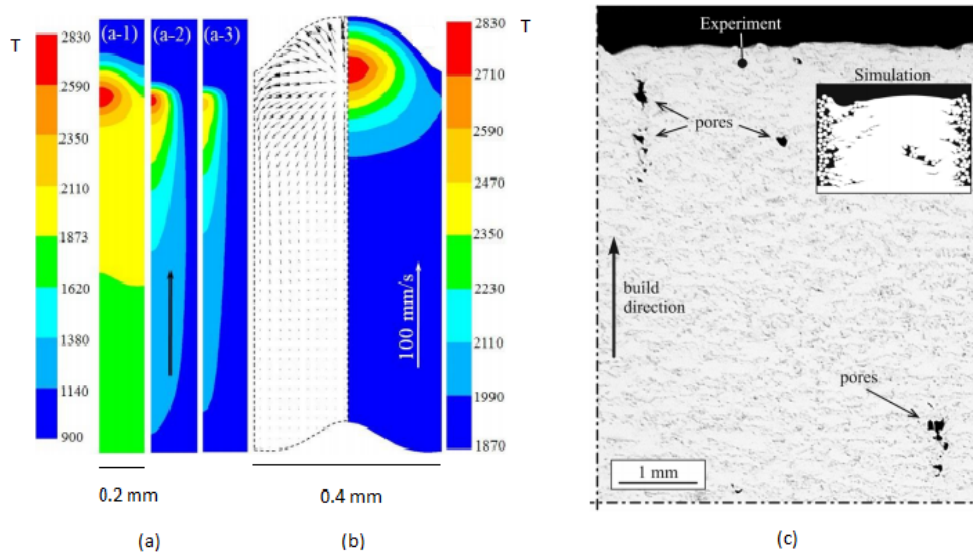
### **2.5.2 Electron Beam Melting models**

The conclusion after reviewing the literature about models for EBM processes is that there has not been as many studies as in other similar technologies like SLM or SLS. Having good models of the process is key to improve the process and having better quality parts. As has been mentioned before, EBM processes use a high power electron beam to melt the powder, so as a matter of principle, the beam-powder interaction is substantially different from other technologies like SLM or laser cladding (LC). The penetration depth of the beam into the powder is higher than the penetration depth of a laser with the same power because electrons have their own inertia and require a high number of collisions (elastic and inelastic) until their kinetic energy is absorbed by the target material. The absorption path of individual electrons can be tracked using Monte Carlo (MC) methods. [83]

Another important aspect is that the maximum energy absorbed by the material is at a considerable distance below the surface, whereas all the energy from a laser is absorbed at the surface. Klaseen et al. [84] showed the strong influence of the electron beam absorption and the depth of penetration on the quality of the part using a 2D thermal Lattice Boltzmann Method in EBM (see Figure 2-17 (c)). They have also developed a strategy to combine different semi-empirical expressions to compute the beam energy attenuation as a function of material characteristics and the incident electron energy.



Zäh and Lutzmann [44] have used a FEA model which solves the heat conduction equation modified by the implementation of an abstracted heat source, to study the influence of beam power and scan velocity on the shape of the melt pool. They validated the model using experimental data from thermocouples attached to the build platform. However, this model has been proven for a set of process variables that avoid two of the most relevant defects in this technology: ball formation and delamination.



**Figure 2-17** (a) Top view of temperature field of EBM at a constant beam current of 14 mA for different scanning velocities (100, 500 and 1000 m/s). (b) Comparison of the heat distribution and fluid convection inside the molten pool (14 mA and 100 m/s). (c) Section of a compact 15×15 mm wall produced by EBM of Ti6Al4V powder utilizing a 60 kV electron beam at a line of 0.3 J/mm. The 2D LBM simulation result is shown at the top right with the same scale as the experiment. [84]

Therefore, better models for predicting melt ball formation during EBM processes, as well as the simulation of the fluid flow in the molten phase, will be necessary.

Jamshidini et al. [85] applied a coupled CFD-FEA to study the heat and thermal stress distribution in EBM with Ti6Al4V powder. This model takes into account the fluid convection through the CFD model and combines it with the FEA model to determine the thermal stresses. They conclude that the power and the cooling rate are the more relevant factors for the thermal stresses, and the

negative temperature coefficient of surface tension is responsible for the formation of an outward flow in the molten pool on the top surface. This effect, combined with the wetting ability of the previously-solidified layer on which new material is melted, results in the formation of melt ball (melt pool instabilities).

According to Gusarov et al. [82], narrow melt pools tend to result in a “balling” effect rather than solidifying as a smooth layer.

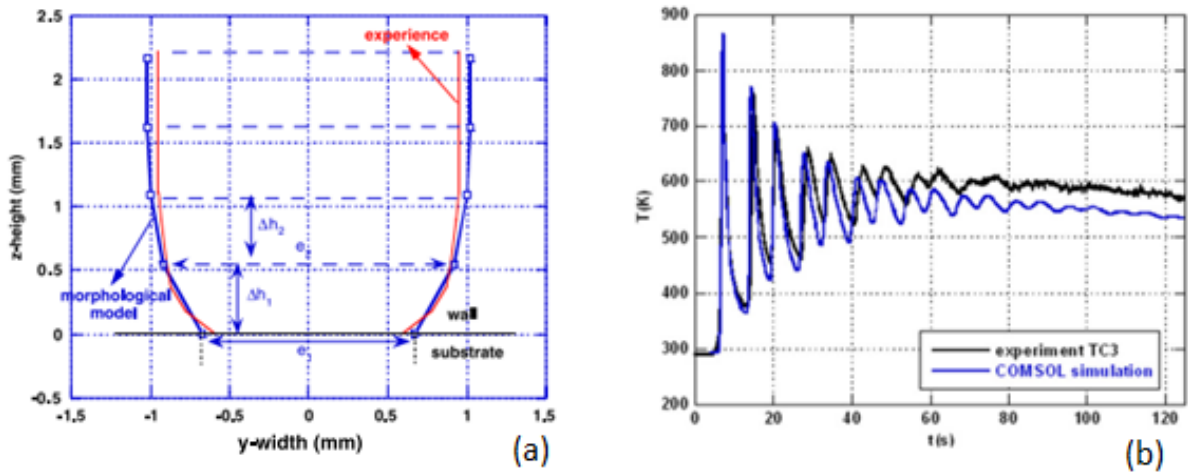
### **2.5.3 Laser Metal Deposition models**

Due to the nature of the process, only the powder melted into the pool contributes to the manufacturing process. As in other AM processes, systematic investigations have been carried out to improve the control of the process and the final quality of the part. Using sensors near the melt pool to record data is very difficult due to the laser heating. Thus, using good models constitutes the only efficient way to predict morphologies, thermal fields, etc.

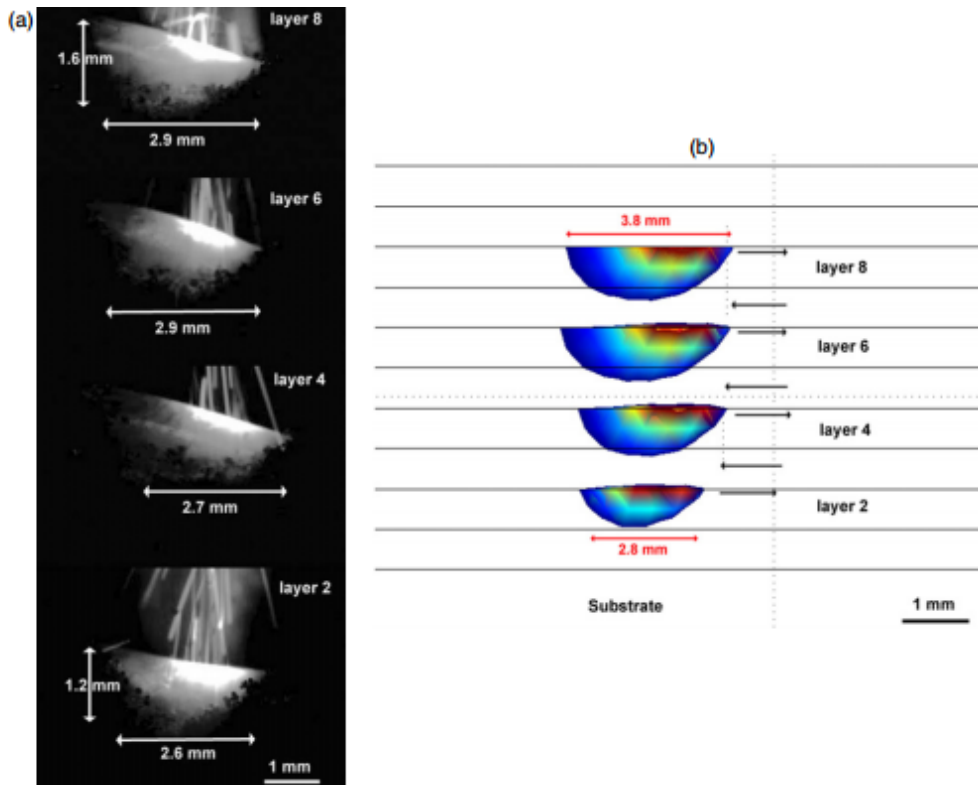
Peyre et al. [86] proposed a combined analytical-numerical model (using COMSOL Multi-physics™ software) to predict geometries and thermal fields during LMD processes with Ti6Al4V powder (see Figure 2-18 and Figure 2-19). Their two main assumptions are:

- Powder arrives at average temperature, and the local mass rate does not interact with the melt pool.
- The energy inside the pool is enough to melt the incoming powder.

To validate their model, they recorded the following parameters: the local temperature history (thermocouples and pyrometers) and the melt-pool size (fast camera). Both sets of data are consistent with simulation data for Ti6Al4V.



**Figure 2-18** (a) Experimental vs simulated data width track. (b) Experimental vs simulated temperatures in the thermocouple model. [86]



**Figure 2-19** Comparison between (a) experimental (1000 Hz c-Mos fast camera) and (b) simulated-induced melt-pools ( $600 \text{ W}$ ,  $0.006 \text{ m s}^{-1}$ ), between the 2<sup>nd</sup> and the 8<sup>th</sup> manufactured layers. [86]

There are many proposed transient models for LMD using FEA. Unlike the previous model these do not use a predictive approach for wall dimension prior

to calculations. Ye et al. [87] used one of these models to predict the temperature distribution for AISI 316 steel. Alimardani et al. [88] proposed a 3D FEA model to calculate the temperature and stress field of each layer as a function of time. This model also includes the Marangoni phenomena (capillarity forces), power attenuation, effect of angle of incidence, and the effect of external forces and displacements. They used this model to investigate how preheating the powder and clamping the part affect the temperature and stress distribution.

Finally, they conclude that preheating the powder helps to reduce residual stresses as well as settling time for the formation of a steady-state molten pool, and clamping the workpiece at specific position also can help to decrease residual stresses.

The material deposition in all FEA models for LMD has been modelled following one of these two major strategies:

- Using quiet elements: element are presented during the analysis but with very low values of thermal conductivity ( $k$ ) and specific heat ( $C_p$ ) in order to reduce conduction into this region. Its major advantages are that it is easy to implement in commercial finite elements solvers and since the number of elements does not change the number of equations is constant and solver initialization during the simulation process is not needed.
- Using inactive elements: elements are not included during the analysis until they has been added. Its major advantage is that it does not need scaling factors to minimize thermal conductivity and specific heat. However, the method is not easy to integrate into commercial finite element solvers.

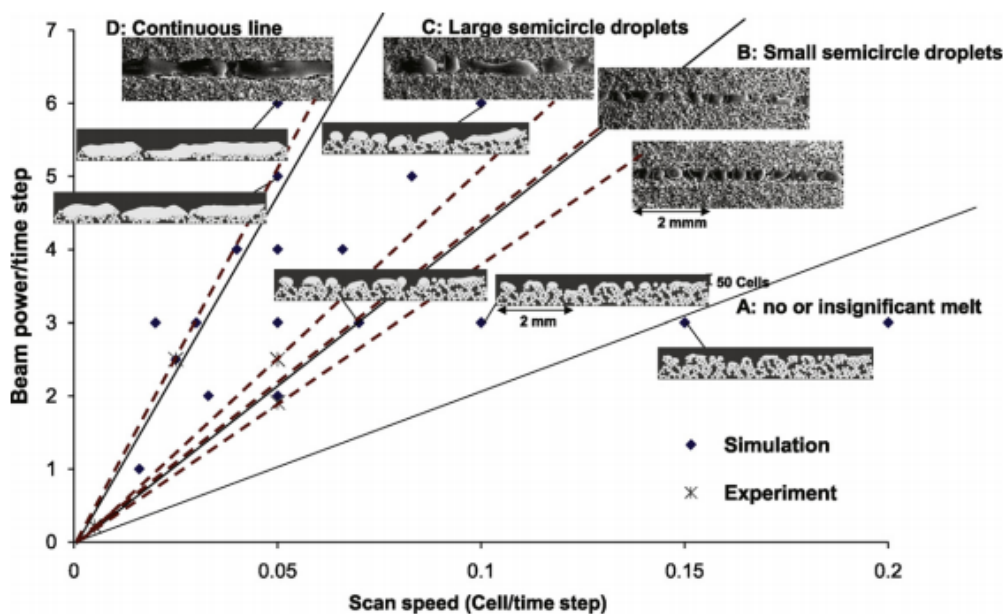
A variety of general purpose commercial software tools have used in these strategies to model metal deposition (Ye et al. [87] use Abaqus™ in their simulations). Michaleris [89] showed that neglecting surface convection and radiation on the interface active-inactive element (or quiet element) result in

artificial heating generation (more than a 5% error), and propose a hybrid inactive/quiet method to accelerate computer run times.

Another important topic is the prediction of the morphology and size of the grain in the final part. The next section constitutes a brief review of mesoscopic models that can be applied to achieve this objective.

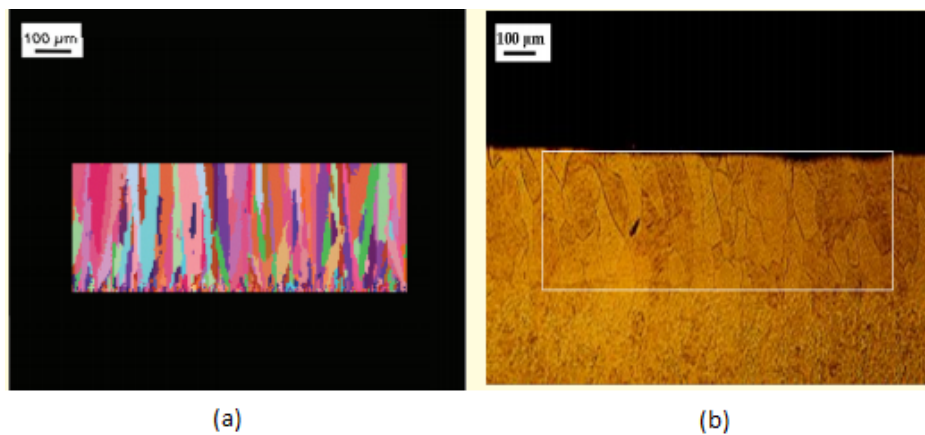
## 2.6 Meso-scale material models

The Lattice Boltzmann Method (LBM) is a mathematical model based on the Cellular Automaton (CA) theory that has been used as an alternative to ordinary fluid dynamics models, especially in problems with complex interface (e.g. flows in porous media). Körner et al. [90] developed a 2D-LBM model to study the influence of melting and solidification of randomly packed powder bed under a Gaussian beam. Their numerical experiments have demonstrated that the packing density of the powder bed has the most significant effect on the melt pool characteristics. Figure 2-20 compares real cases with the LBM simulation.



**Figure 2-20** Processing maps for Ti6Al4V. Experimental results and mesoscopic simulations for SLM. [90]

CA modelling has also been used to simulate the evolution of the microstructure during the solidification process as an alternative to Phase-Field Models (PFM). [91] For instance, Gandin et al. [92] developed a three dimensional CA combined with FEA to predict the grain structure in casting processes. Such models permit estimating the thermal gradient and cooling rate needed in casting to obtain a specific grain structure (equi-axial, columnar, etc.). Kobryn et al. [26] developed a model to predict the microstructure solidification in Ti6Al4V for SLM for thin-wall and bulky 3-D geometries. This model has been successful in predicting the fully-columnar microstructure associated with SLM at relatively small scales (see Figure 2-21).



**Figure 2-21** CA predicted and observed microstructure in thin-wall LENS™ (Q=370 W, V=12.5 mm/s). [26]

## 2.7 Certification in the aerospace market

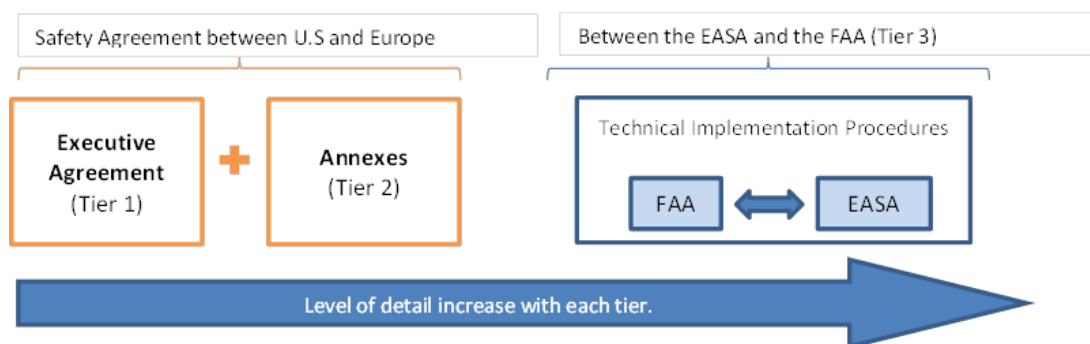
Implementing AM to produce and repair aerospace components (parts and tools) requires, not only being competitive against conventional manufacturing methods in terms of time and cost, but also meeting all the part's requirements and ensuring that each aspect of its value chain can be certified. AM faces many technical challenges when compared to other conventional manufacturing processes (like casting or forging, amongst others), such as the mechanical properties of the resulting part, the complexity of the deposition system, the reuse of the powder, etc.

AM implementation in the design, manufacturing, and repair stages for aerospace components must be in concordance with the corresponding competent authority to ensure aircraft airworthiness and air transport safety.

The European Aviation Safety Agency (EASA) and the Federal Aviation Administration (FAA) are the two major organisations that are responsible for standards of safety and environmental protection in civil aviation, not only in their region but also for those countries which have bilateral agreements. The United States has a bilateral agreement in place with the European Union. This agreement covers three different areas:

- The Executive Agreement; provides the framework for all cooperation between the U.S and EU to promote a high degree of safety in air transport and to enable the reciprocal acceptance of findings of compliance and approval issued by the Technical Agent and Aviation Authorities).
- Annexes I and II: Annex I covers airworthiness [93] and environmental certification and Annex II covers maintenance.
- The procedures and guidance material to support the Annexes.

Additional Annexes are currently being negotiated. It is important to clarify that this bilateral agreement between the U.S and Europe promotes reciprocal acceptance of findings and approvals, not mutual recognition. In other words, it is an agreement “On Cooperation in the Regulation of Civil Aviation Safety”. Figure 2-22 shows components of the new aviation safety agreement format.



**Figure 2-22** Components of the new aviation safety agreement format. [94]

On 20 November 2006, the European Commission adopted Regulation (EC) No 2042/2003 [95] whose two main objectives are to ensure the continued airworthiness of any aeronautical product (adopting common technical requirements and administrative procedures) and to create a technical regulation which all organizations and personnel involved in the maintenance of aeronautical products must fulfil in order to ensure, demonstrate, and take responsibility for the work performed. Regulation (EC) No. 2042/2003 has four Annexes. [95]

Annex I (Part M) focuses on all processes that ensure that an aircraft complies with airworthiness requirements in effect during its operational life and that it can be operated safely, including maintenance.

Annex II (Part 145) describes the necessary conditions for an organization to be approved in Maintenance, Repair and Overhaul (MRO) operations. [96] Each competent authority shall establish procedures detailing how to comply with Part 145, Section B.<sup>4</sup> These procedures must be reviewed and amended to ensure continued compliance. Annex II specifies:

- Requirements that have to be met by staff and equipment.
- Maintenance planning.
- The control of the recording process of maintenance work.
- The quality and safety policy of the organisation is in accordance with the structure of the organisation.

Annex III (Part 66) describes the training necessary to acquire the license for aircraft maintenance technicians (AMT). [97]

Annex IV (Part 147) describes “how” and “where” this AMT formation should be taught. [98]

Part 21 lays down the rules governing the airworthiness and environmental certification of an aircraft, related products, parts and appliances, as well as the

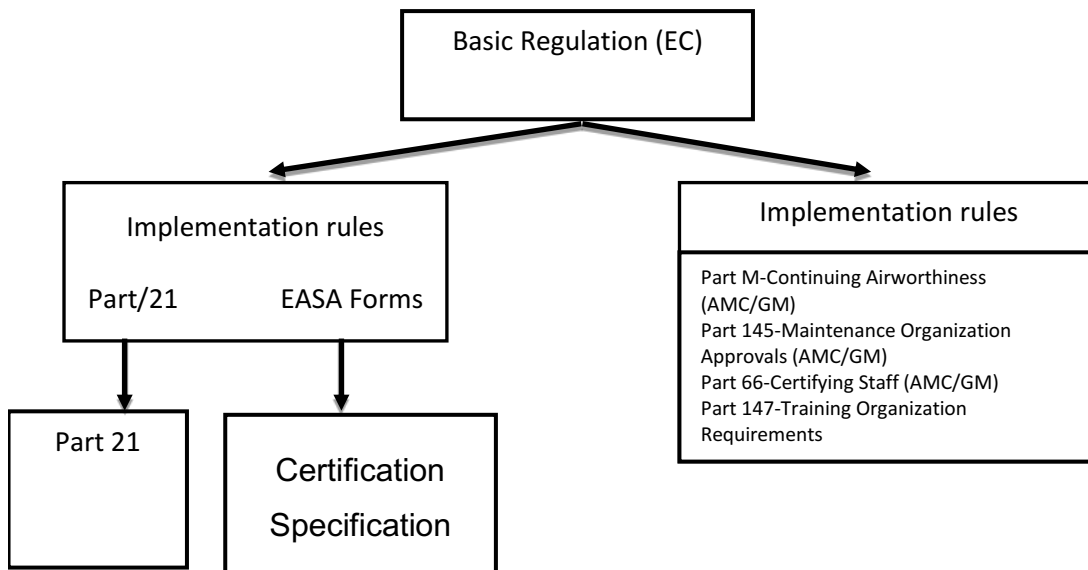
---

<sup>4</sup> Competent authorities are designated by each Member State of the European Union (EU) or by the Agency if so requested by that Member State.



certification of design and production organisations<sup>5</sup>. It specifies the legislation on certification procedures, producing parts and devices, type certificates requirements for noise emissions, approvals parts and systems, individual certification of airworthiness, flight permits and restricted licenses. [99]

As some rules may be subject to interpretation, EASA issues advisory material to explain regulation and, in some cases, suggests suitable procedures to perform a demonstration of compliance with it. The Acceptable Means of Compliance (AMC) and the Guide Material (GM) are documents that have been issued with each Annex. Figure 2-23 shows a chart of EASA regulations.



**Figure 2-23** EASA regulations. [93]

Finally EASA regulations and their correspondent Annexes can be summarized as:

*“An aircraft that has been designed by an organization approved under Part-21 may only be operated for commercial air transportation when an operator has hired a maintenance organization that has been approved under Part-145,*

---

<sup>5</sup> A design organisations must hold a Design Organisation Approval (DOA) and provide the design data to a production organisation, which in turn must hold the correspondent Production Organisation Approval (POA)

*which uses certifying staff according with Part-66 and they have been trained according with the Part-147.”*

The idea of bringing AM into MRO requires meeting European Commission Regulations (regulations related with initial airworthiness, Part-21; and continuing airworthiness Part-145, Part-M, Part-147 and Part-66).

## **2.8 Current AM standards**

The AM industry is starting to respond to the need for standardisation at a global level. As a consequence, various committees, with substantial European involvement have been formed. The most important ones are the ASTM F42 Committee [100] and the ISO TC 261. Both of them have identified priority topics for standardization, in particular: qualification and certification methods [101; 102], design guidelines [101; 102], test methods for characteristics of raw materials [101; 102], material recycling guidelines [101; 102], and standards protocols [101-103], requirements for purchased AM parts, harmonization of existing ISO/ASTM terminology standards [21; 104] and testing for finished parts. One of the main challenges of standardization is the diversity of AM technologies and the need to categorize them accordingly. Some standards have been published and others are in progress, but they must also be assessed and accepted by the aerospace industry and the corresponding aviation authority. The chart provided in Figure 2-24 shows the plan structure of the ASTM F42 Committee.

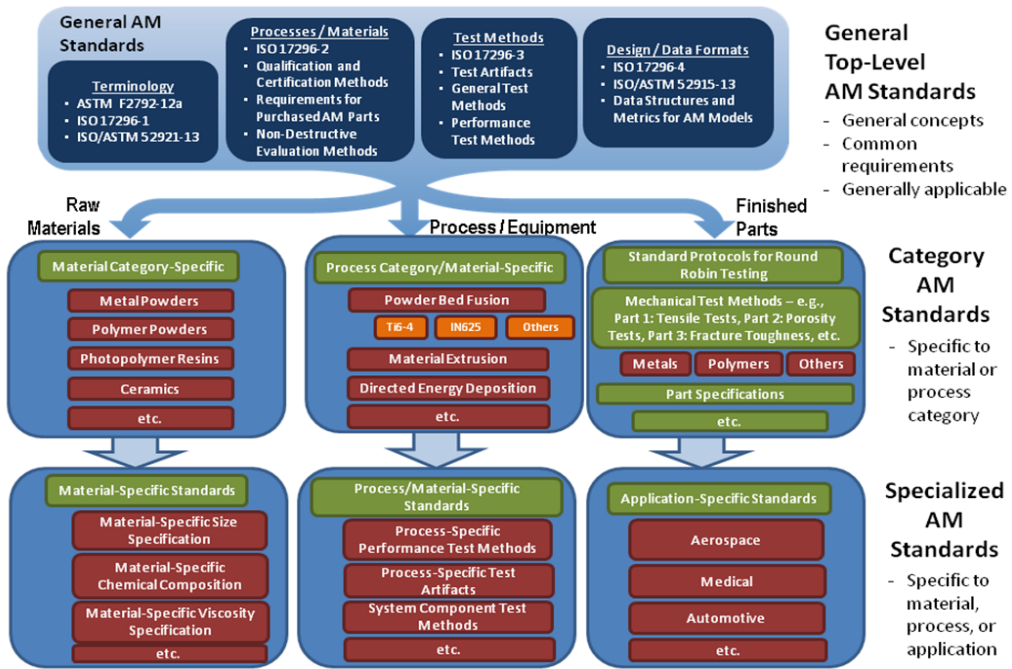


Figure 2-24 ASTM plan to develop AM standards.

**Table 2-7** Collection of AM standards.<sup>6</sup>

| <b>ASTM STANDARD</b>           |   |
|--------------------------------|---|
| F42.01 Test methods            | F2971-13 Standard Practice for Reporting Data for Test Specimens Prepared by Additive Manufacturing   |
|                                | F3122-14 Standard Guide for Evaluating Mechanical Properties of Metal Materials Made via Additive Manufacturing Processes                         |
|                                | ISO/ASTM52921-13 Standard Terminology for Additive Manufacturing-Coordinate Systems and Test Methodologies  |
|                                | <i>WK40419 New Test Methods for Performance evaluation of Additive Manufacturing systems through Measurement of a Manufactured Test Piece.</i>    |
|                                | <i>WK43112 New Guide for Evaluating Mechanical Properties of Materials Made via Additive Manufacturing Processes.</i>                             |
| F42.04 Design                  | ISO/ASTM52915-13 Standard Specification for Additive Manufacturing File Format (AMF) Version 1.1  |
|                                | <i>WK26367 New Terminology for Lattice Structures</i>   |
|                                | <i>WK37892 New Guide for General Design using Additive Manufacturing</i>  |
|                                | <i>WK38342 New Guide for Design for Additive Manufacturing</i>  |
| F42.05 Materials and Processes | 2924-14 Standard Specification for Additive Manufacturing Titanium-6 Aluminum-4 Vanadium with Powder Bed Fusion                                   |
|                                | F3001-14 Standard Specification for Additive Manufacturing Titanium-6 Aluminum-4 Vanadium ELI (Extra Low Interstitial) with Powder Bed Fusion     |
|                                | F3049-14 Standard Guide for Characterizing Properties of Metal Powders Used for Additive Manufacturing Processes                                  |
|                                | F3055-14e1 Standard Specification for Additive Manufacturing Nickel Alloy (UNS N07718) with Powder Bed Fusion. See also WK47167 proposed revision |
|                                | F3056-14e1 Standard Specification for Additive Manufacturing Nickel Alloy (UNS N06625) with Powder Bed Fusion                                     |
|                                | F3091/F3091M-14 Standard Specification for Powder Bed Fusion of Plastic Materials   |
|                                | <i>WK28741 New Specification for Electron Beam Melting (EBM) Titanium 6Al-4 V ELI</i>   |
|                                | <i>WK26106 New Specification for Material Qualification for Additive</i>  |

<sup>6</sup> Standards in cursive are being developed as of December 2014.

|                      |  |
|----------------------|--|
|                      | <i>Processes</i>   |
|                      | <i>WK26105 New Specification for Material Traceability for Additive Processes</i>  |
|                      | <i>WK26102 New Specification for Metrics for Initial Conditioning of Machines &amp;/or Performance Metrics for Metal Deposition</i>                    |
|                      | <i>WK25296 New Specification for Electron Beam Melting (EBM) Titanium 6Al-4V</i>   |
|                      | <i>WK25479 New Guide for Conditioning of Machines and Performance Metrics of Metal Laser Sintering Systems.</i>  |
|                      | <i>WK30557 New Specification for Standard Specification for Laser Sintering High Melt Temperature Polymers for Non-Structural Aerospace Components</i> |
|                      | <i>WK46201 New Specification for Extrusion Based Additive Manufacturing of Plastic Materials</i>   |
|                      | <i>WK33833 New Specification for Additive Manufacturing Cobalt-28 Chromium-6 Molybdenum with Powder Bed Fusion</i>                                     |
|                      | <i>WK37654 New Practice for Machine Operation for Directed Energy Deposition of Metals</i>   |
|                      | <i>WK40638 New Guide for the Roadmap of F42.05 Materials and Process Subcommittee on Additive Manufacturing</i>  |
|                      | <i>WK46188 New Practice for Metal Powder Bed Fusion to Meet Rigid Quality Requirements</i>   |
| F42.91 Terminology   | F2792-12a Standard Terminology for Additive Manufacturing Technologies. See also WK38531 and WK47540 proposed revisions                                |
|                      | <i>WK26433 New Terminology for Directed Energy Deposition Additive Manufacturing Technologies</i>  |
| <b>ISO STANDARDS</b> |  |
|                      | ISO/ASTM 52915:2013. Standard Specification for Additive Manufacturing file Format (AMF) Version 1.1   |
|                      | ISO/ASTM 52921:2013. Standard Terminology for Additive Manufacturing -- Coordinate Systems and Test Methodologies                                      |
|                      | ISO 17296-4:2014. Additive Manufacturing -- General Principles -   |

|  |  |
|--|--|
|  | - Part 4: Overview of Data Processing  |
|  | ISO 17296-3:2014. Additive Manufacturing -- General Principles -<br>- Part 3: Main characteristics and Corresponding Test Methods  |
|  | ISO/DIS 17296-1. Additive manufacturing -- General principles --<br>Part 1: Terminology  |
|  | ISO/ASTM NP 52915. Standard Specification for Additive<br>Manufacturing File Format (AMF) Version 1.1  |
|  | ISO 17296-2. Additive Manufacturing -- General Principles -- Part<br>2: Overview of Process Categories and Feedstock   |
|  | ISO 28219:2009.Packaging -- Labelling and Direct Product<br>Marking with Linear Bar Code and Two-Dimensional Symbols   |
| <b>VDI TECHNICAL RULES<sup>7</sup></b> |  |
|  | VDI 3404: Additive Fabrication: Rapid Technologies (Rapid<br>Prototyping): Fundamentals, Terms and Definitions, Quality<br>Parameters, Supply Agreements                 |
|  | VDI 3405: Additive Manufacturing Processes, Rapid<br>Manufacturing- Basics, Definitions, Processes   |
|  | VDI 3405, Part 1: Additive Manufacturing Processes, Rapid<br>Manufacturing – Laser Sintering of Polymer Parts –Quality<br>Control  |
|  | VDI 3405, Part 2: Additive Manufacturing Processes, Rapid<br>Manufacturing – Beam Melting of Metallic Parts –Qualification,<br>Quality Assurance and Post Processing     |
|  | <i>VDI 3405, Part 2.1. Additive Manufacturing Processes, Rapid<br/>Manufacturing - Beam Melting of Metallic Parts - Material Data<br/>Sheet Aluminium Alloy AlSi10Mg</i> |
|  | <i>VDI 3405, Part 3: Additive Manufacturing Processes, Rapid<br/>Manufacturing- Design Rules for Part Production Using Laser<br/>Sintering and Laser Beam Melting</i>    |

---

<sup>7</sup> The Association of German Engineers standards.

## 2.9 Summary

Unlike other manufacturing processes, AM is neither adequately understood nor characterized to establish a combination of fixed process parameters, acceptance testing, Non-Destructive Inspection (NDI), and destructive coupon testing, to confirm if it complies with all requirements. With the current state of this technology in terms of design, qualification, process specifications, and standardisation, it is difficult for the aerospace industry to develop a single specification and associated database for AM for a given alloy. In other words, when all variables in the AM process are fixed and the process becomes stable and controlled, the resulting mechanical properties are well-characterized and sufficiently invariable, the structural performance of AM parts is predictable using conventional design tools, and the ability to accomplish post-processes is demonstrated (like machining or drilling), only then can AM be considered a viable option in the aerospace industry.

A repair or recreation using an AM process has to be developed by an approved design organization (Part-21, Sub J) or an organization with comparable capabilities. The introduction of AM as a new production and repair method has to be classified as a major design change (GM 21.A.91) and a major repair (21.A.435(a)) [99]. The new process has to be approved (for alternative procedures, see 21.A.14(b) [99]) by national aviation authorities following point 21.A.97 [99] and resulting in approved records that include all relevant data for a specific repair solution.

An MRO service provider with design organization approval has to approve the new repair design and append a supplemental page to the applicable Maintenance Manual GM 21.A.431 (a) [105], 145.B.4 [96] (e.g. Component Maintenance Manual). An OEM (Original Equipment Manufacturer) has to approve the repair solution and include it in the applicable Maintenance Manual (21.A.14 (b) 3.4 [99]). A repair solution has to be conducted according to the applicable Maintenance Manual and its amendments. Finally, an EASA Form 1 has to be issued referencing all relevant data.

Traditional manufacturing methods for metallic components have well-established specifications and procedures, and this means that protocols for certifying processes and suppliers are similarly well-established. Nowadays, many research efforts are being dedicated by different committees around the world to develop standardization for AM processes in order to establish the terminology, material, processes and test methods. This will allow AM technology to compete and participate in the aerospace market under the same conditions as conventional manufacturing processes.

From the point of view of the qualification of AM in the aerospace industry, there are significant challenges because of the following reasons:

1. Standardization is not yet well established. However, the ASTM F42 Committee is working to overcome this challenge. ASTM has issued several standards on AM addressing terminology, file format, and the processing of various alloys.
2. The conventional certification processes for aircraft components can be very costly and, in some cases exceed US\$130 million and last more than 15 years. [106] Thus, new alternative means are needed to accelerate these processes.
3. Lack of methods to verify key process variables and demonstrate repeatability.
4. Need for a clear definition of qualification requirements for each of the three phases of product life-cycle, new design/repair, and production.
5. New advanced NDT techniques capable of detecting critical flaws and defects with a high degree of certainty are needed.



## **3 Research objectives and methodology**

### **3.1 Introduction**

The aim of the RepAIR project is to develop procedures and tools that can be IT supported to facilitate the certification process in both the repair as well as the recreating of parts, by the Organizations or Organization Units as is defined in the Commission Regulation (EU) N° 748/2012 and the Commission Regulation (EC) No 2042/2003.

The Repair project does not include certification approval by the Competent Authority. All the interactions with the EASA in order to reach its particular approval were not considered in the scope of the project. Therefore, the parts repaired or recreated by the “Repair project”, the machines, the monitoring systems and the IT platform developed during the project will not be approved by EASA at the end of the project.

### **3.2 Aim and objectives**

The aim of this project is to define and develop a Qualification Procedure (QP) for Selective Laser Melting (SLM) and Electron Beam Melting (EBM). This qualification procedure will be used to assess the influence of key variables/parameters in both technical requirements of parts and process reproducibility. The QP requires the assessment and control of key raw materials, consumables and process parameters; the development of common practices for each AM component; the verification of each fixed practice via NDI and destructive testing; and part-specific acceptance testing (both NDI and destructive testing) to ensure the integrity of the final parts.

To achieve this aim, the following objectives were defined at the beginning of the MSc by Research;

- Review the state of the art of the affected regulation.
- Identify relevant characteristics of AM technologies that affect directly the requirements of the aerospace industry.

- Identify and study all the relevant parameters of SLM and EBM techniques and their capability.
- Study various real MRO cases, and identify the potential tasks that can be substituted by AM in the process.
- Study other similar aerospace manufacturing technologies (e.g. welding) and their Qualification Procedure.
- Develop QA/QC procedures in accordance with the quality standards and the characteristics of the technology.
- Definition of the structure and registers of the library part and repair strategies database with AM.
- Identify relevant aspects of AM related to certification.

The output of the QP will identify: key variables/factors with a relevant impact on the part performance, the allowance range of key factors, and the relevant data to predict the structural and chemical behaviour of the part.

Then, new General Procedures (GP), Operational Instructions (OI), and Control Procedures (CP) are developed for both technologies. These are part of the QA/QC system of a company, and can be implemented to monitor key factors and verify if they are within the allowance range

Concepts about quality have been defined in compliance with the following standards:

- EN 9100:2009. "Quality Management Systems -- Requirements for Aviation, Space and Defense Organizations".
- ISO 9000:2005 "Quality Management Systems -- Fundamentals and Vocabulary"
- ISO 9001:2008 "Quality Management Systems -- Requirements"
- EN 9110:2010 "Quality Management Systems -- Requirements for Aviation Maintenance Organizations".

To develop these QA/QC procedures a general action plan was carried out during this research to achieve the objectives. Table 3-1 contains a general

descriptions of all the necessary steps to implement a QA/QC system

**Table 3-1** General QA/QC steps.

|                      |  |                           |
|----------------------|--|---------------------------|
| 1 <sup>st</sup> STEP | <ul style="list-style-type: none"> <li>- Part information and requirements</li> <li>- General identification of the manufacturing process.</li> <li>- Overall validation of the process and equipment.</li> <li>- Risk management.</li> </ul>  |                           |
| 2 <sup>nd</sup> STEP | <ul style="list-style-type: none"> <li>- Planning of the production process (from receipt to delivery)</li> <li>- Process diagram.</li> <li>- Work instructions.</li> <li>- Monitoring and measurement of product</li> </ul>   |                           |
| 3 <sup>rd</sup> STEP | <ul style="list-style-type: none"> <li>- Calibration plan.</li> <li>- Plan maintenance (including clean room)</li> <li>- Product identification and traceability.</li> <li>- Record of the collecting product features requested per customer</li> <li>- Showing suppliers: preliminary assessment.</li> <li>- Documents of purchase.</li> <li>- Identification and development of indicators and quality objectives.</li> </ul> |                           |
| 4 <sup>th</sup> STEP | <ul style="list-style-type: none"> <li>- Preparation of received control registers, control production, control of nonconforming product, complaints.</li> <li>- Control reception start-up</li> <li>- Control production and delivery start-up</li> <li>- Customer feedback start-up</li> <li>- Data analysis and improvement start-up</li> </ul>   |                           |
| 5 <sup>th</sup> STEP | <ul style="list-style-type: none"> <li>- Document management.</li> <li>- Configuration management</li> <li>- Human resource management.</li> <li>- Responsibilities.</li> <li>- Transfer work control</li> </ul>   | Elaboration of procedures |
| 6 <sup>th</sup> STEP | <ul style="list-style-type: none"> <li>- Internal quality audit</li> </ul>   |                           |
| 7 <sup>th</sup> STEP | <ul style="list-style-type: none"> <li>- Certification audit (first phase)</li> </ul>  |                           |
| 8 <sup>th</sup> STEP | <ul style="list-style-type: none"> <li>- Review the quality system by the management</li> <li>- Certification audit</li> </ul>   |                           |

Another important topic is the regulatory framework of the aerospace industry. Much research has been done about this area in this MSc by Research in order to identify the most relevant aspect that affects these procedures [101-103]. Figure 3-1 shows an overview of the influence of the regulatory framework on the RepAIR decision concept.

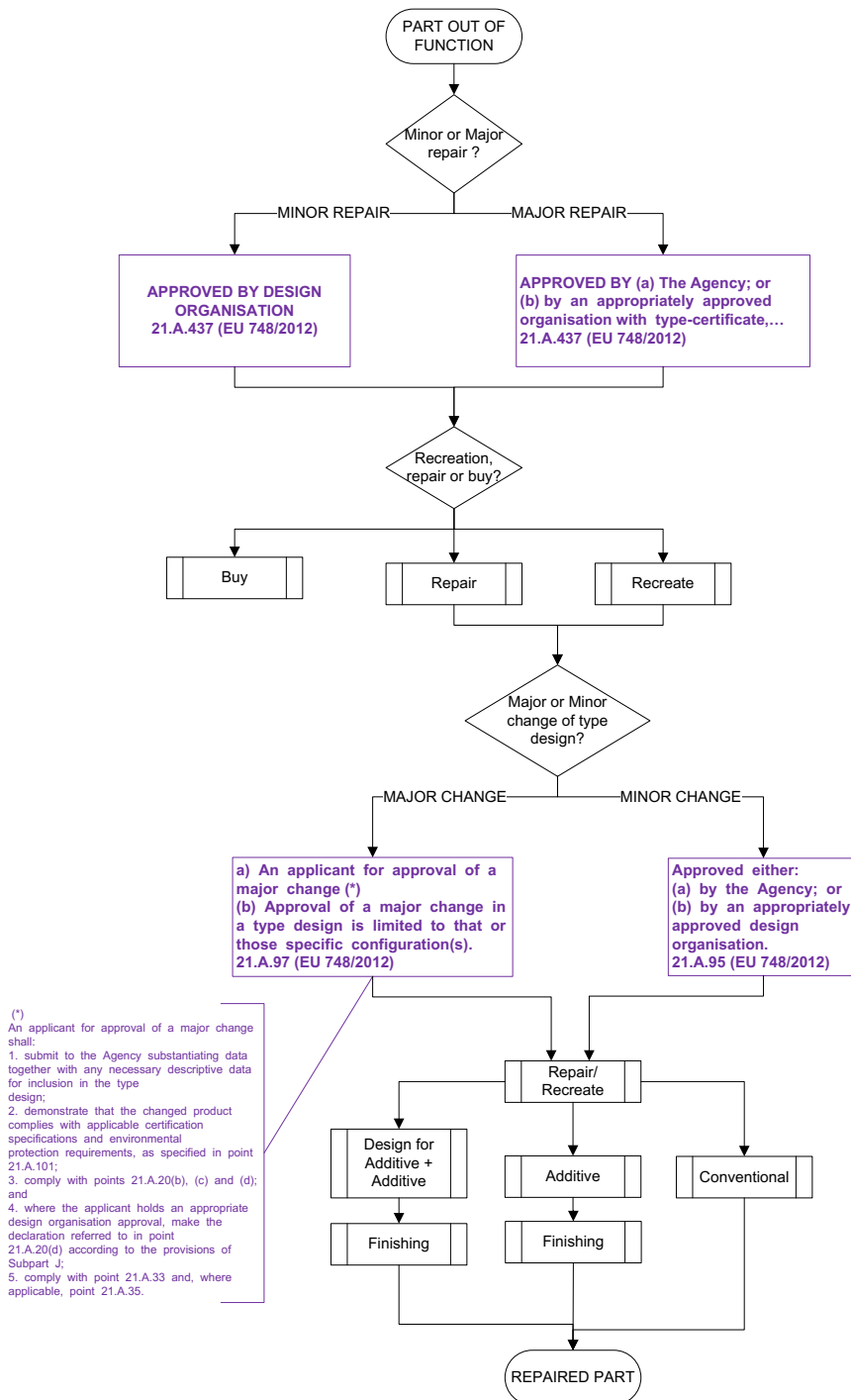


Figure 3-1 Influence of the regulatory framework in the RepAIR concept.

### 3.3 Problem statement

To summarise the previous point and taking into account the extensive literature review carried out in Chapter 2, the following problem statement can be formulated as follows:

- Scope:

This research analyses the introduction of additive manufacturing techniques into the Maintenance, Repair and Overhaul operations in the aerospace industry by firstly developing a Qualification Procedure (QP) for these technologies, and then developing all the General Procedures (GP), Operational Instructions (OI), and Control Procedures (CP) that have to be implemented in the QA/QM processes.

- Assumption:

At the beginning of this research, the maturity of the AM technology has been considered sufficient to achieve high performance parts.

- Hypothesis:

It is possible to qualify some AM technologies in the aerospace sector. This is taken into consideration in the previously stated assumption. This will be the basis for developing the correspondent procedures, operational instructions and control procedures for the QA/QC system.

- Research questions:

What is the process by which these AM technologies can be qualified for the aerospace sector?

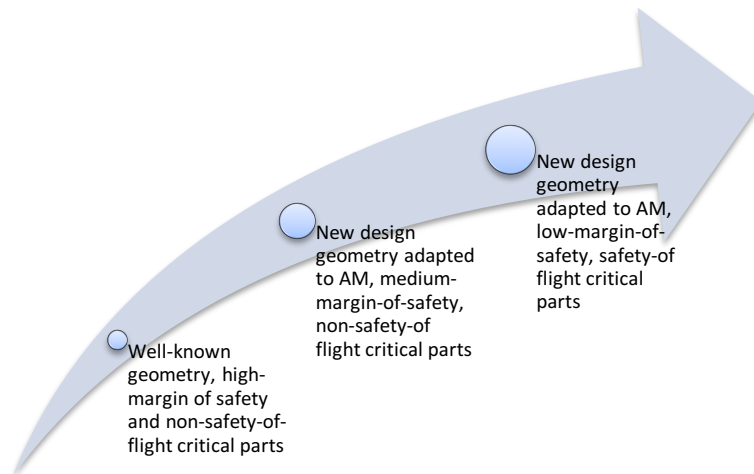
What are the most important aspects in the Maintenance, Repair, and Overhaul operations related to QA/QM and the certification process, and how could these new technologies be introduced in those processes?

Which quality assurance procedures (in terms of general procedures, operational instructions and control procedures) must be developed taking into account characteristics of the technology?

### 3.4 Methodology

This section details the methodology that was followed during this MSc by Research.

The overall project follows a scenario-based approach starting with specific sample parts with a well-known geometry, high margin of safety, and where AM is applicable. Afterwards, it can be continued with new design geometries adapted to AM with medium margin of safety (see Figure 3-2). This strategy to introduce a new manufacturing process is more in accordance with the knowledge maturity of the technology and it can achieve one practically relevant demo case at the end of the project (RepAIR).



**Figure 3-2** Feasible implementation strategy.

Firstly, the strategy would be to research the analogy between AM and legacy manufacturing methods for metallic materials, and then identify the relevant points in conventional qualification processes for these manufacturing technologies that are well-established and accepted for the aircraft market. Then, it will be necessary to define and implement new processes and activities in accordance with the characteristics of AM in order to have a specific qualification procedure for SLM and EBM.

### **3.4.1 Analysis of production, supply chain and workflow management system**

As mentioned before, the overall project follows a scenario-based approach with defined sample parts. In the same bottom-up approach, these parts were the starting point for analysing requirements from a technical point of view.

Experts in each specific field know the capabilities of each technology best and follow their recommendations. To analyse AM production, the respective partners have defined which sample parts they want to repair or recreate and how they plan to do the repair or recreation. To get a common understanding on what level of abstraction is needed from the individual processes, an overall production process for repair and recreation will be modelled and discussed. Then, all those who contribute to a production technology were asked about their individual production processes. A graphical and contextual analysis of the various models was developed in order to identify similarities, analogies and distinctions.

Assumptions of possible controls for every process step have been made and led to a conceptual workflow.

This consecutive approach will lead to a basis for analysing requirements from the technological perspective.

### **3.4.2 Repair processes**

Core processes related with the repair of a part in a workshop have been studied and represented in a flow chart based on the results of interviews from an MRO service-provider (see Appendix A). Furthermore, relevant support processes, like build up capabilities, have also been studied.

To save project resources of own and supporting partners in the project, interviewing techniques were used scarcely. Interviews will be performed with only one person in charge of the process and will be validated by e-mail request.

Furthermore, they will be

- verified by a further MRO provider and an OEM and
- proven by EASA regulations and by literature.

Introducing manufacturing technologies that have never been applied in the aerospace industry to produce or repair products, and parts and appliances will have a huge impact on the certification process, and therefore on the QA/QC procedures related with those tasks. From this perspective, two main potential applications have been identified in the literature review (see Chapter 2):

1. The versatility of AM technology allows optimising a part of a product. The “bracket” is the case study for this proposal. The goal is to produce and optimize it reducing the amount of material needed.
2. Once the part fails or is close to failure, there are two options to evaluate during the MRO operations:
  - i. Reproduce the component using AM. Again, the “bracket” is the case study for this proposal.
  - ii. Repair the component using AM. The RepAIR project has two case studies. One is a “HPT Shroud”, and the other is an “Impeller”.

### **3.4.3 Case studies**

This MSc by Research presents the results related with both cases the “bracket” and the “HPT shroud”.

To use AM technology for repairing or recreating spare parts and to certify the conducted work by issuing EASA Form 1<sup>8</sup>, the following steps have to be performed:

- A permanent repair design including AM repair or AM recreation process steps has to be developed by a Part 21J organization or an organization with comparable capabilities.<sup>9</sup>

---

<sup>8</sup>[EASA145] 145.A.50



- Since repair with additive technologies has not been previously accepted as appropriate for spare parts of aircraft, the introduction of this new production method has to be classified as a major design change<sup>10</sup> and therefore as a major repair<sup>11</sup>. Thus the new process has to be approved<sup>12</sup> by national aviation approval authorities resulting in approved data for a specific repair solution (temporary repairs<sup>13</sup> are out of the scope of this document). There are two different possibilities:
  - a. An MRO service provider with design organization has to approve the repair design and append a supplemental page (STC) to the applicable Maintenance Manual<sup>14</sup> (e.g. Structural Repair Manual, Engine Manual, Component Maintenance Manual etc.).
  - b. An OEM has to approve the repair solution and include it in the applicable Maintenance Manual.<sup>15</sup>
- A repair solution has to be developed according to the applicable Maintenance Manual and its amendments.
- A repair for a sample part arriving at the workshop has to be derived/assembled according to its failure modes and available approved repair solutions.
- The repair has to be processed and approved according to the relevant procedure.
- EASA Form 1 for SRU has to be issued referencing all data arising from the repair.

---

<sup>9</sup>[EASA21] 21.A.433

<sup>10</sup>[EASA21] GM 21.A.91 3.3 (iii)

<sup>11</sup>[EASA21] 21.A.435 (a), [EASA21] GM 21.A.435 (a) 1. and especially [EASA21] GM 21.A.435 (a) 2. i)

<sup>12</sup>[EASA21] AMC 21.A.14 (b) 3.3.3

<sup>13</sup>[EASA21] GM 21.A.437 3)

<sup>14</sup>[EASA145] GM 21.A.431 (a)

<sup>15</sup>[EASA21] AMC 21.A.14 (b) 3.4

- A repair for a sample part (like the HPT shroud) arriving at the workshop has to be derived/assembled according to its failure modes and available approved repair solutions.
- The repair has to be processed and approved according to the derived/assembled repair.
- EASA Form 1 for SRU has to be issued referencing all data arising from repair.

The abovementioned process has to be done for every combination and change of AM production process (e.g. selective laser melting, laser cladding, electron beam melting, etc.), failure mode and part.

Two repair case studies will be presented in this MSc by Research thesis, the first a Boeing bracket, which is a representative structural part from a large airplane. As has been mentioned before, the repair scenario for this case study will consist in replacing a damage part with a complete new one that has been manufactured by AM. The basis for the certification of this part is the CS-25 Subpart D (see Table 3-2). The new design of the component needs to be approved following the Part-21 basis. The highest failure mode frequency of the part is bending due to an overload on the component (it represents 69% of the total faulty parts). Thermal issues as well as thermal interaction with other components are not relevant. The technical specifications for material, once the part has been manufactured are:

- Yield strength: 786 MPa
- Ultimate tensile strength: 862 MPa
- Elongation: 8%
- Reduction in area: 15%
- Modulus of elasticity: 117 GPa

The other case study is an engine part: the HPT Shroud from the CFM 56 2/3. As it has been mentioned before, the repair scenario for this case study will consist in eliminate the damage region of the part, and rebuild on it the correspondent geometry. This scenario is much more complex than the other

one, because its damage region as well as its severity changes from one case to another. The basis for the certification of the repair part is the CS-E (see Table 3-2). The new repair design of the component needs to be approved following the Part-21 basis. For this case study, some of steps of the current repair process have been substitute by AM. The main failure mechanism of this part is rubbing and hot corrosion. Both the exposure to high temperatures and the rubbing events may lead to a severe deterioration the shroud up to the point where it is necessary to repair it. The technical requirements specified by the OEM are<sup>16</sup>:

- The build/up material must be free of any crack and excessive oxides
- No lack of fusion and missing material
- No undercutting

The HPT shroud repair process is constituted by a set of defined steps. Only some of them will be replaced by AM technology. Following the diagram presented in chapter 4 (see Figure 4-28), the steps to eliminate the lateral faces, and re-build them with the correspondent slots have been substitute by using selective laser melting. This will reduce the amount of time of the repair process and will make it more autonomous.

**Table 3-2** Case studies.

| <b>Study case</b>      | <b>Operation</b> | <b>Type change</b> | <b>Reasons [105]</b>   |
|------------------------|------------------|--------------------|--|
| HPT shroud (CFM56-2/3) | Repair           | Major              | <ul style="list-style-type: none"> <li>- It is a structural part which requires a re-substantiation of fatigue and static load determination used during certification.</li> <li>- The change implies new material or processes.</li> <li>- The change can affect its Remaining Useful Life</li> </ul> |

<sup>16</sup> The technical values are property of the OEM.

|         |           |       |  |
|---------|-----------|-------|--|
|         |           |       | (RUL)<br>- The change can affect or introduce engine critical parts (CS E-510) or their RUL.   |
| Bracket | Reproduce | Major | - It is a change that adversely affects fatigue or damage tolerance or its life limit characteristics.<br>- It changes material, processes or method of manufacture of primary structural elements, such as critical parts <sup>17</sup> . |

---

<sup>17</sup> The term “critical part” or “critical component” is used in various EASA requirements, certification specifications and also in the EU-US bilateral agreements, however a general definition does not exist. In the case of the HPT shroud, which is an engine part, the definition can be found at the CS-E. It says “*Engine Critical Part: means a part that relies upon meeting the prescribed integrity specifications of CS-E 515 to avoid its Primary Failure, which is likely to result in a Hazardous Engine Effect*”. However, for the Boeing bracket, which constitutes a structural part, following the CS-25 a critical part can be defined as any part whose failure endangers the airworthiness of the aircraft.

## **4 Qualification Procedure for AM**

### **4.1 Introduction**

With the lack of technology maturity in terms of design, qualification, process specifications and standardisation, it is difficult for the aerospace industry to develop a single specification and associated database for AM of a given alloy.

The AM process itself is not sufficient to produce an aircraft component. Heat treatments, such as stress relief or Hot Isostatic Pressing (HIP), are required to improve structural behaviour (see Section 2.4.3). Machining the surface is required to improve the roughness, the dimensional accuracy, and to prevent initiation of surface cracks.

Therefore, specification processes for each aircraft component should be defined from the beginning.

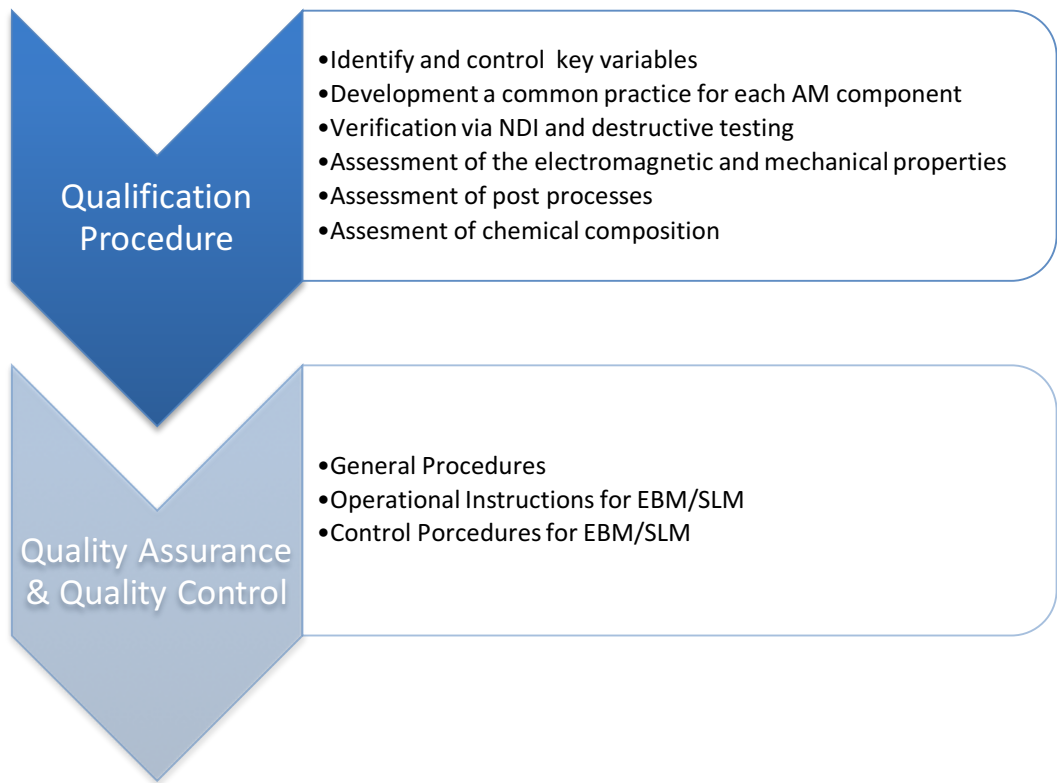
The Qualification Procedure (QP) is an important issue for implementing AM in the aerospace market. This can be defined as a methodology by which all critical parameters and their allowance ranges are identified, and the repeatability of the process is also guaranteed. In other words, the QP is the method used for the assessment of all the variables/factors suitable to influence both technical requirements of the final part and process reproducibility.

The QP requires the assessment and control of key raw materials, consumables, and process parameters; the development of a fixed practice for each AM component; the verification of each fixed practice via NDI and destructive testing; and part-specific acceptance testing (both NDI and destructive testing) to ensure the integrity of parts.

This chapter presents a novel QP for EBM and SLM to reach the reproducibility of the results. This result would be the basis for the new QA/QC procedures (see Chapter 5).

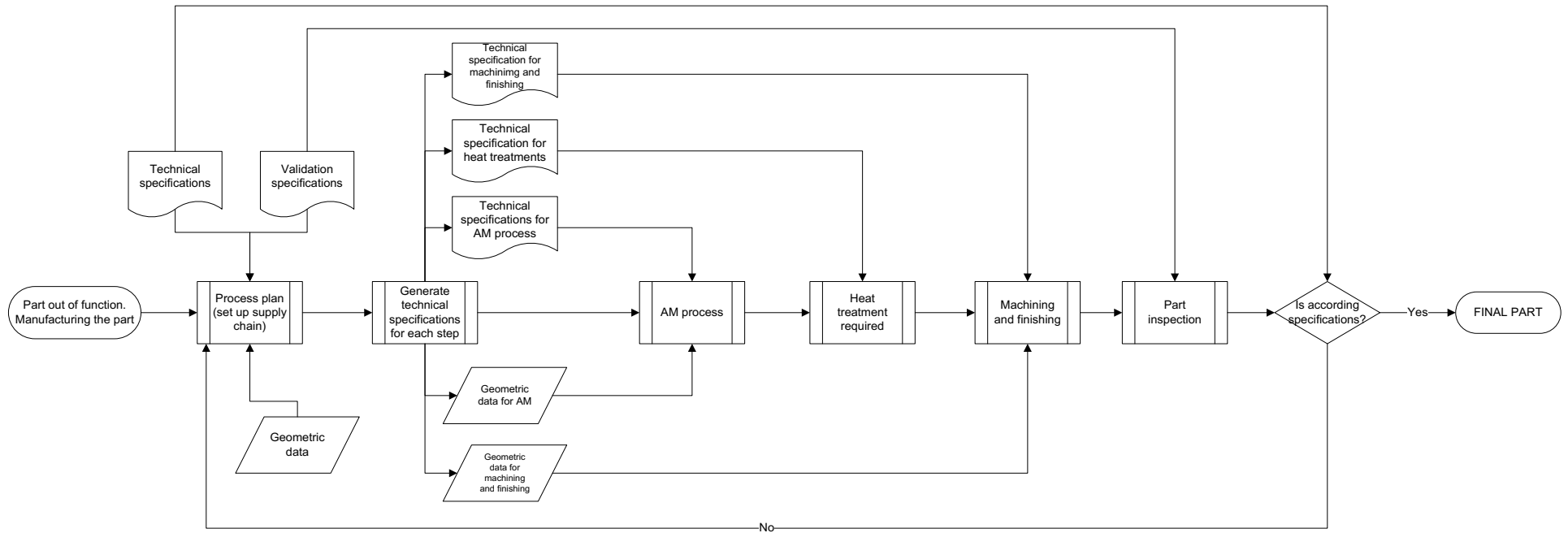
Furthermore, a set of selected studies have been defined to complete the QP.

Figure 4-1 shows an overview of the QP.

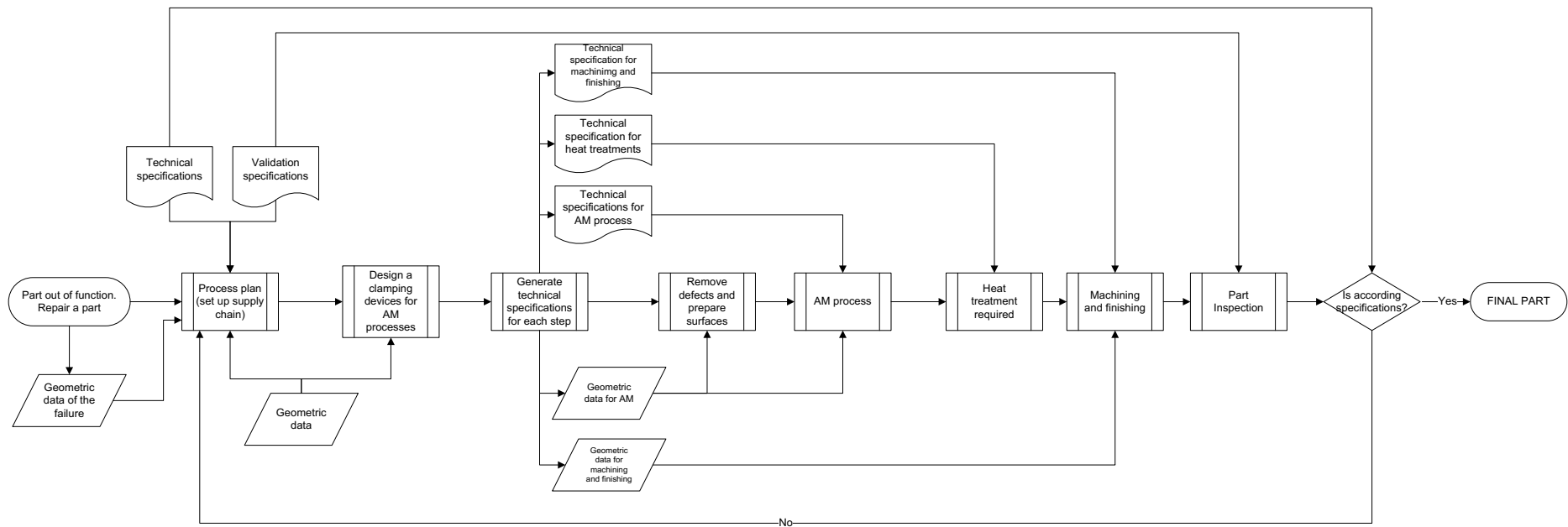


**Figure 4-1** Thesis overview.

Figure 4-2 and Figure 4-3 show a scheme of all steps required for manufacturing or repairing a part considering AM technologies.



**Figure 4-2** Manufacturing an aircraft component considering AM technologies.



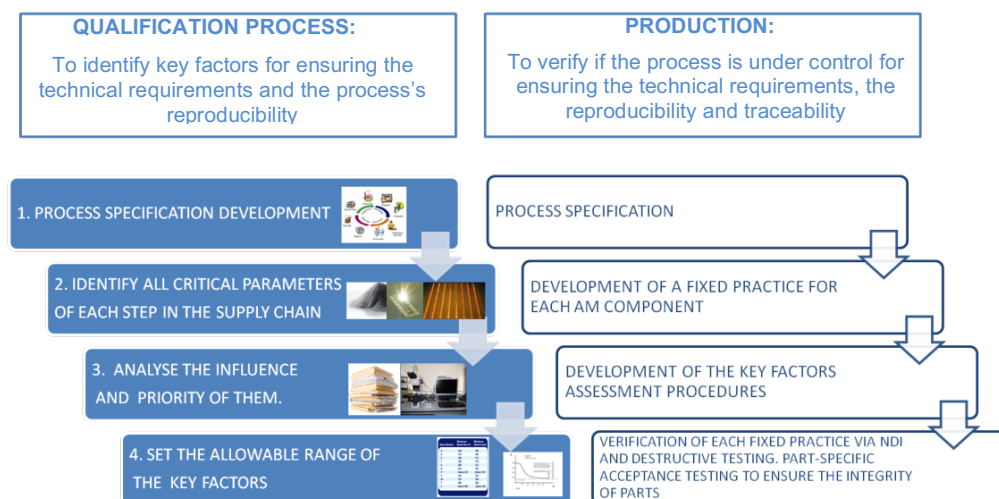
**Figure 4-3** Repairing an aircraft component considering AM technologies.



## 4.2 Qualification Procedure for EBM/SLM

The Qualification Procedure (QP) is a method used for the assessment of all the variables/factors that can influence both, technical requirements of the final part and process reproducibility. QP is based on the expertise and knowledge of all the processes considered in the supply chain. It takes into account potential dependencies between different process variables in the specification procedure.

After analysing main characteristics of EBM and SLM (see Section 2.3), a list of the relevant parameters and the definitions of both technologies were carried out (see Appendix E). Then, taking into consideration the opinion of various experts from the aerospace sector, the following QP approach for EBM/SLM was created (see Figure 4-4).



**Figure 4-4** General approach for the Process Qualification Procedure.

Following Figure 4-4, the QP can be divided into the following four steps:

### 1. PROCESS SPECIFICATION DEVELOPMENT

In this step, a process specification should be developed for manufacturing/repairing each aircraft's component. As part of the process specification, the AM process and post-processes should be established based on technical requirements from the component, such as:

- Material(s) specification(s). Material standards establish the proper chemical composition, and some conditions for purchasing, storing, handling or processing the material. They usually reference other standards related to testing methods to assess mechanical properties. From this point of view, special attention has been given to the standards published by the ASTM F-42 and TC-261 standardisation group.
- Geometry. Apart from 3D file model, dimensional, geometric and surface tolerances must be specified.  
In order to have better fatigue behaviour (see Section 2.4.3), the roughness of the surface is crucial. The machining of the surface is necessary, which means that all the extra material needed must be in the 3D solid model file.
- Usage conditions. It provides information related to its usage, such as load conditions, environment conditions –chemical, temperature range, pressures range, humidity range-, interactions with other parts or systems, etc.
- Failure modes. It provides information about the possible failure modes such as type, frequency, location, and mean repair/replace time.
- Traceability. It provides information and documentation about the Process-history. It includes information about raw materials, consumables, sub processes, personnel, NDT testing, machinery and technologies, post-processes, and the part's location amongst others.

Therefore, the process specification for manufacturing or repairing a component should be established based on all the information previously gathered. As a conclusion, each process specification should include:

- All the manufacturing/repairing techniques used for achieving the final part: the specification of the AM technologies and the corresponding heat and surface treatments required after manufacturing the part.
- The raw material processed by the manufacturing/repairing techniques: the specification of the powder, the use conditions, the recyclability of the powder, the ageing allowed for the powder, the performance variance of the process and, the powder blend procedure.
- AM process plan. It requires establishing the geometries to be built per cycle. Each cycle is constituted by an individual build platform constitutes a cycle.

Depending on the processes' specifications, it would be necessary to build different test samples per cycle to check the mechanical properties, chemical composition and microstructure. Other considerations must be considered, such as the location of the parts in the building platform and the manufacturing orientation.

- Post-processing plan. It provides relevant information about any post-processes required to meet the technical requirements. This information would include the geometries required in each post process; the fixtures developed for machining and the strategy to obtain a surface quality part; the heat treatment settings for stress relief and/or improving the microstructure and the HIP settings for reducing the porosity level.
- Assessment plan. It establishes a set of studies to conduct the assessment of the part and the process via Non-Destructive Testing (NDT) and destructive tests.
- Process reproducibility. It establishes the required number of cycles to guarantee its reproducibility.

## 2. IDENTIFY KEY VARIABLES AND PARAMETERS

During the manufacturing or repairing process it is important to know about the potential dependencies between all involved variables<sup>1</sup> and parameters<sup>2</sup>. From this point of view, is also important to take into consideration variables from other manufacturing or repairing processes that directly affects to the final result of the part.

Critical variables<sup>3</sup> must be monitored during the manufacturing process. In order to have a better understanding of its influence on the manufacturing process, the following group classification has been carried out:

- Plant
- Raw material

---

<sup>1</sup> A value that can change during the manufacturing process, and affects the final result (e.g. scan speed, voltage, laser power and hatch space)

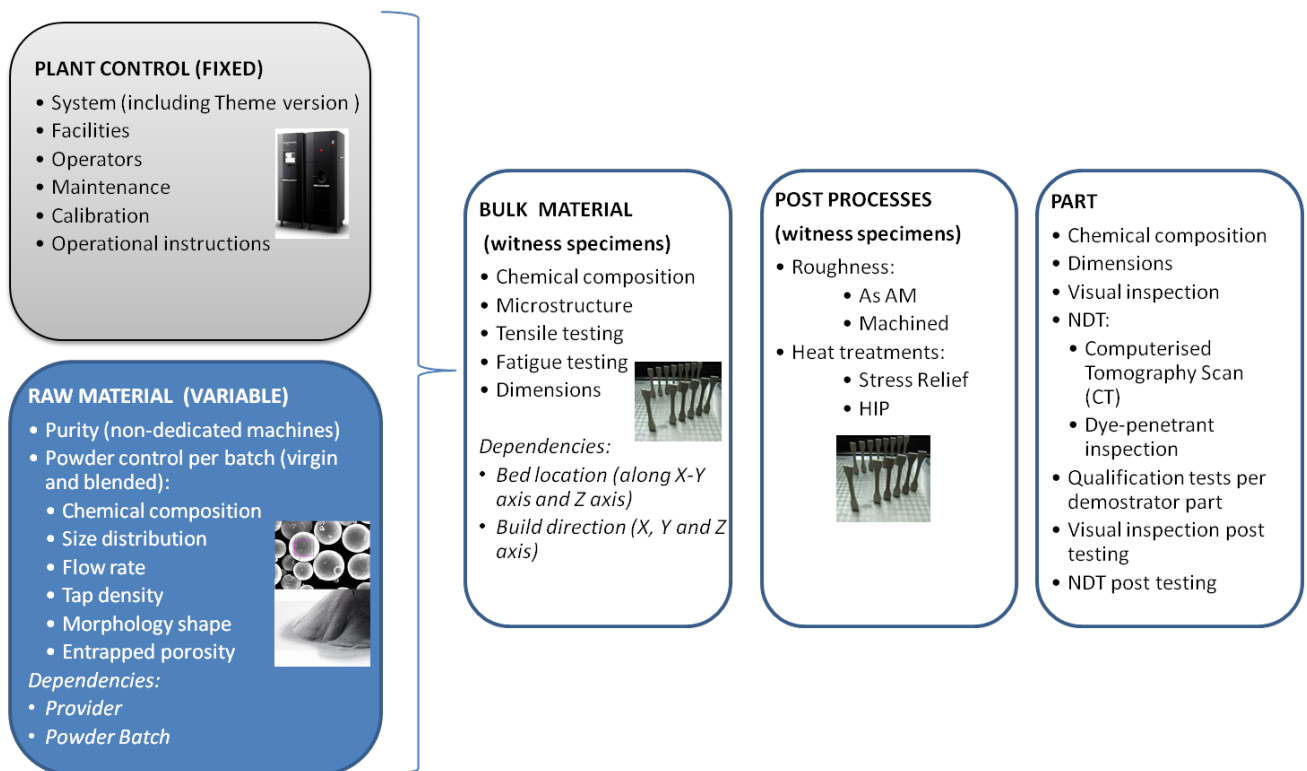
<sup>2</sup> A value that does not change during the manufacturing process, and can affect the final result (e.g. thermal conductivity of the raw material, absorptivity, and emissivity)

<sup>3</sup> Any variable that has a high impact on the final manufacturing result.

- Bulk material
- Post processes and,
- Part.

In the QP, some of the variables are invariable between cycles and batches. In the following they will be called “fixed” variables.

Figure 4-5 shows the preliminary organisation of all the critical variables and parameters.



**Figure 4-5** Preliminary definition of AM process parameters classified in groups.

### 3. INFLUENCE OF VARIOUS CRITICAL PARAMETERS AND VARIABLES

In order to study the influence of parameters and variables previously cited and classified during the manufacturing process, various studies are set up.

Taking into account results from various EBM/SLM results [56; 66; 107-109], the following studies are defined:

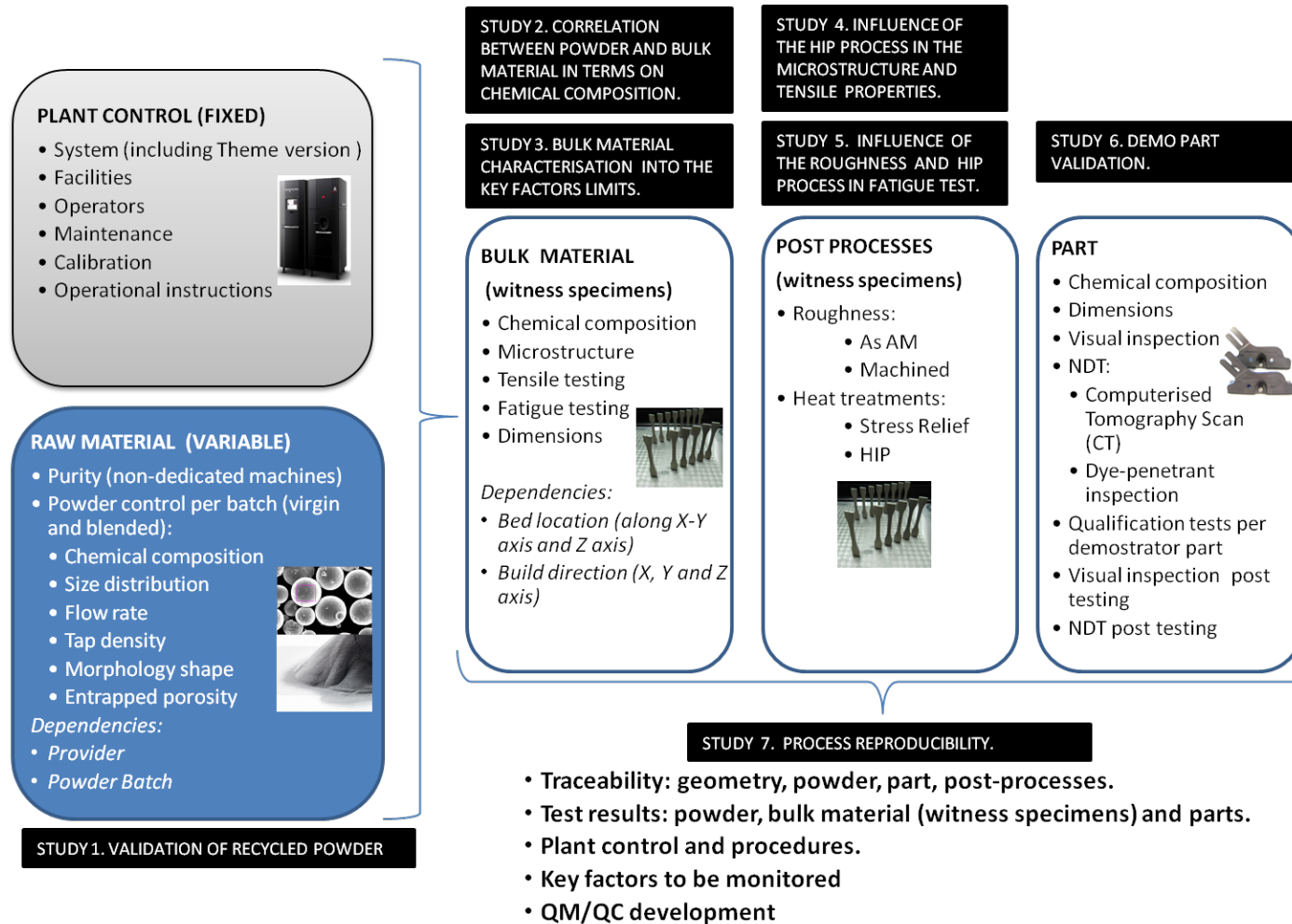
- Study 1: Validation of the recycled powder. Some powder parameters change if the powder has been recycled, including the flow rate, chemical composition, and morphology shape amongst others.

- Study 2: Correlation between bulk and powder material. During the manufacturing process, various phenomena, which directly affect the mechanical and chemical properties of the material occur [35; 59; 60; 69].
- Study 3: Bulk material characterization. It is important to determinate the operating window of the technology [44].
- Study 4: Influence of HIP on the microstructure and mechanical properties [110].
- Study 5: Influence of HIP and surface machining on the fatigue behaviour.
- Study 6: Demo part. NDT techniques and methods are needed to interrogate features that are unique to these parts, such as fine scale porosity, complex part geometry, and intricate or inaccessible internal features. The overall goal will be to understand the types of naturally occurring flaws produced by the AM process, what their effects are, and what NDT techniques are best suited for their detection. Specific uses of NDT to characterize AM parts may include the following:
  - Neutron diffraction to characterize the internal stress state
  - High-resolution, high-speed, high-power CT for parts with geometrical complexity, deep porosity, or inaccessible features.
  - NDT metrology for monitor build accuracy during processing, or measuring finished part dimensional accuracy and tolerances using structured (laser/white) light.
- Study 7: Process reproducibility.

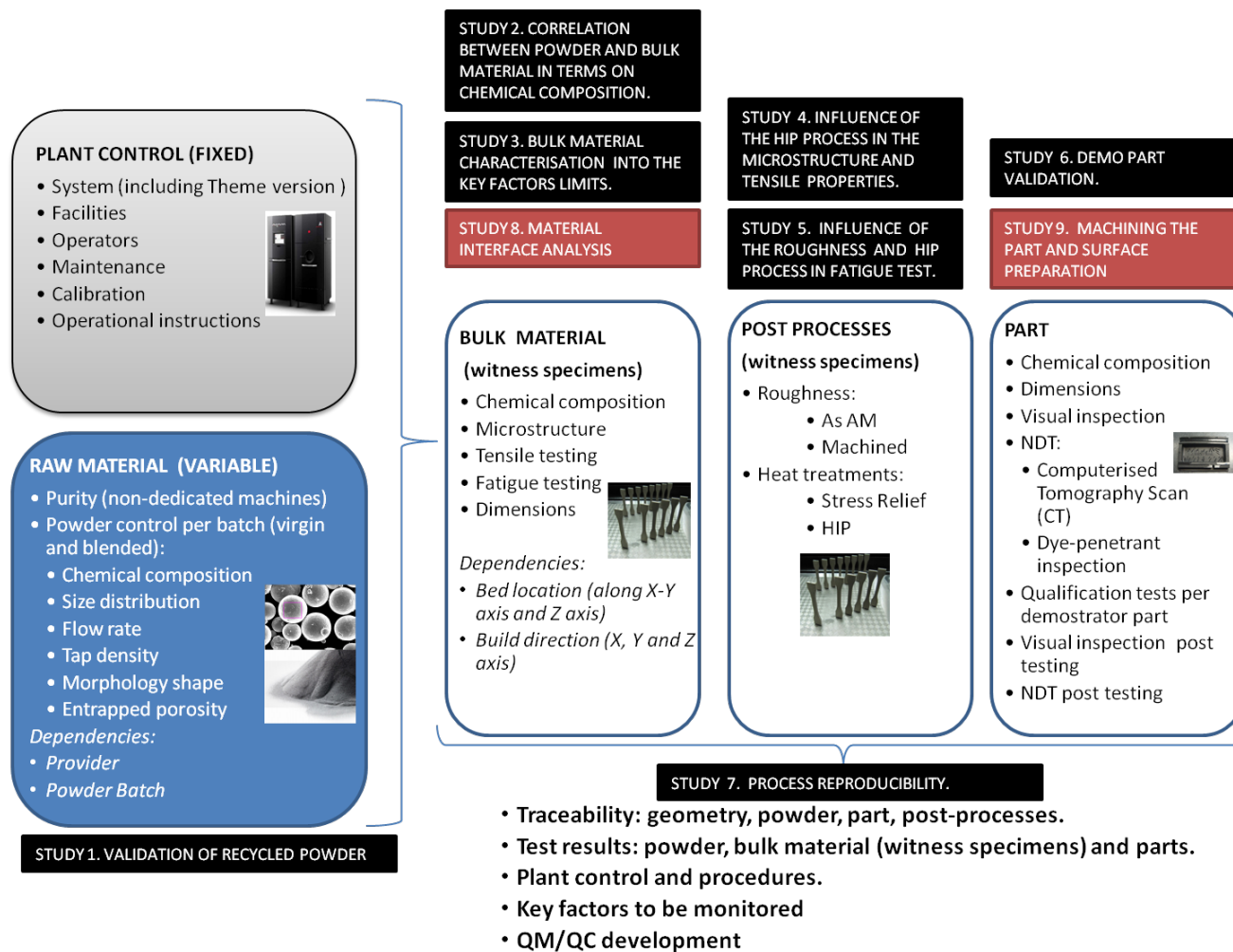
Figure 4-6 and Figure 4-7 describe the studies to be carried out in each classification group, keeping in mind that some additional studies would be considered in the repair process. This occurs due to the “hybrid” nature of the final part. When a part has been repaired adding material on a substrate, both can be different in terms of microstructures and chemical compositions. The “transition zone” between both materials will have its own characteristics. For these reasons, the following studies must be added into the QP for a repair operation:

- Study 8: Interface characterization.
- Study 9: Surface preparation.

These proposed studies are explained and presented in Section 4.4.1 for the “Boeing” bracket.



**Figure 4-6** Definition of the studies to be carried out for AM qualification (manufacturing).



**Figure 4-7** Definition of the studies to be carried out for AM qualification (repair).



#### **4. TO SET UP THE ALLOWABLE RANGES OF THE KEY FACTORS**

Finally, once key factors and their allowance ranges have been fixed, it is possible to determine if the manufacturing process has been successful.

Allowance range factors set, during the manufacturing process, taking relevant decisions to achieve the desired quality level. The evaluation of key factors must be implemented in quality control procedures (QMS).

#### **4.3 Boeing “bracket” Qualification Procedure**

The QP approach proposed in Section 4.2 is based on: recommendations from standards (see Section 2.8) and their corresponding standard relationships; information about common manufacturing processes from the stakeholder; procedures for manufacturing components with AM from the OEM<sup>21</sup>; and opinions from experts in the field.

As has been mentioned before, each QP needs to be developed for each aerospace component. As has been described at the beginning of this document, two case studies are considered in the project, the “bracket” and the “HPT shroud”, but only the bracket’s QP for EBM and SLM is presented in this thesis. Figure 4-8 and Figure 4-9 show the QP value-stream for each technology.

The technical requirements of the two demonstrators mentioned are included in Section 4.4.

---

<sup>21</sup> Original Equipment Manufacturer

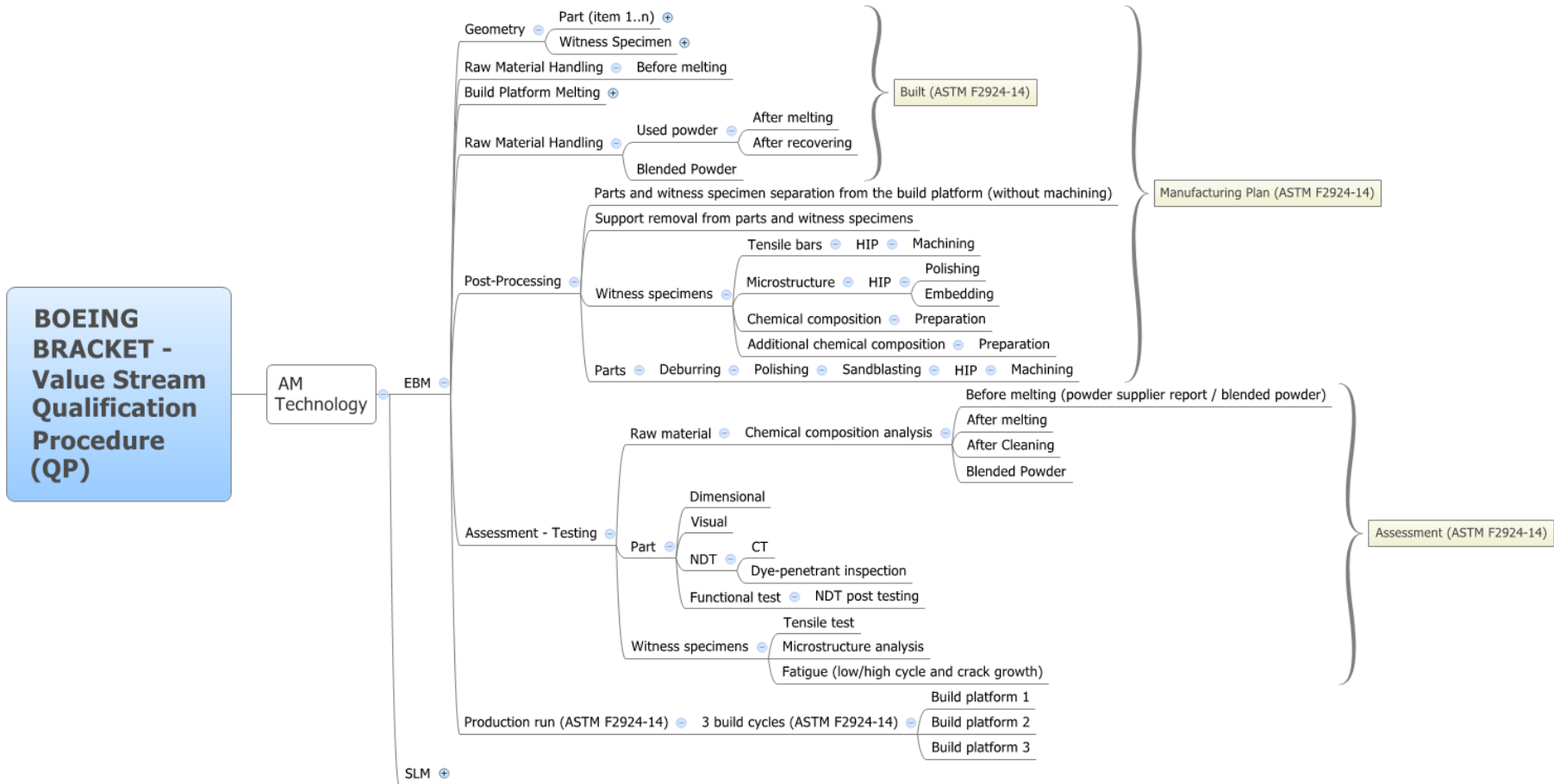
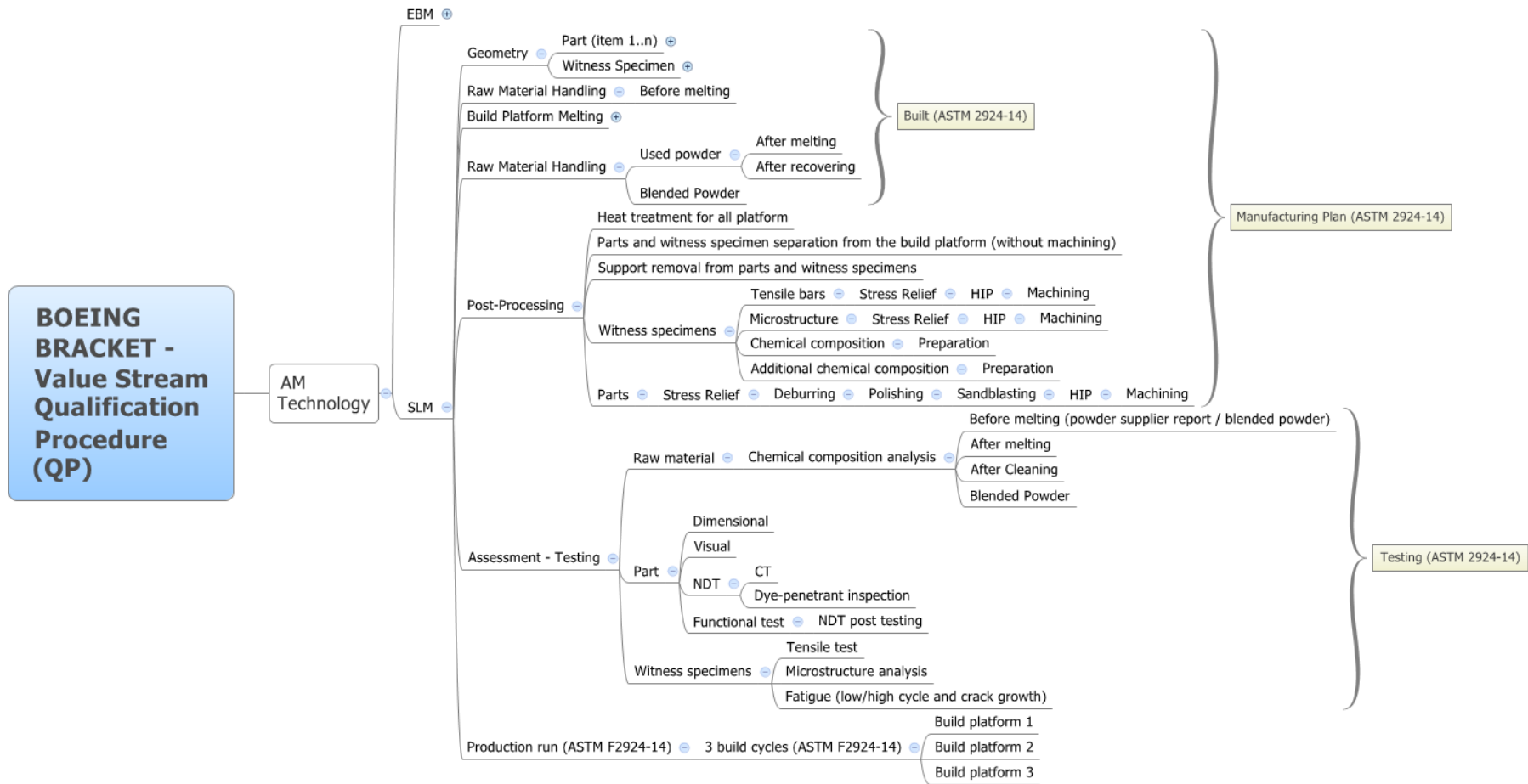


Figure 4-8 Boeing bracket-Value stream qualification procedure for EBM.



**Figure 4-9** Boeing bracket-Value stream qualification procedure for SLM.

Study 1: Validation of recycled powder.

Standard “ASTM F2924-14 Standard Specification for Additive Manufacturing Titanium-6 Aluminium-4 Vanadium with Power Bed Fusion” [101] considers the feedstock as the most important parameter to be controlled during the process.

- Metal powder shall be free from detrimental amounts of inclusions and impurities.

**TABLE 1 Composition**

| Element               | min       | max   |
|-----------------------|-----------|-------|
| Aluminum              | 5.50      | 6.75  |
| Vanadium              | 3.50      | 4.50  |
| Iron                  | —         | 0.30  |
| Oxygen                | —         | 0.20  |
| Carbon                | —         | 0.08  |
| Nitrogen              | —         | 0.05  |
| Hydrogen              | —         | 0.015 |
| Yttrium               | —         | 0.005 |
| Other elements, each  | —         | 0.10  |
| Other elements, total | —         | 0.40  |
| Titanium              | remainder |       |

**Figure 4-10** Ti6Al4V chemical composition after processing. [101]

- Used powder is allowed. The proportion of virgin powder and used powder shall be recorded and reported for each production run. The maximum number of build cycles that the powder can be recycled must be fixed. Mixed powder must meet the chemical composition presented in Figure 4-10.

The aim of this study is to know the degradation of metal powder during the AM build cycles for each AM technology involved in the project (EBM and SLM). The powder parameters to be controlled are:

- Purity of the powder.
- Powder control, the aim is to determine the variance for different batches (virgin and blended):
  - Chemical composition. For at least the most critical elements such as nitrogen, oxygen and hydrogen.
  - Size distribution.
  - Flow rate.
  - Tap density.
  - Morphology shape.

- Entrapped porosity.

Table 4-1 includes all the tests that have been chosen to characterize the powder. Due to the lack of specific tests for AM, some of them come from similar manufacturing technologies (like welding).

**Table 4-1** Powder tests based on corresponding standards.

| <b>Test Required</b>    | <b>Test Standard</b>  |
|-------------------------|---|
| Chemical Analysis       | <ul style="list-style-type: none"> <li>- ASTM E2371. Test method for analysis of titanium and titanium alloys by direct current plasma and inductively coupled plasma atomic emission spectrometry.</li> <li>- ASTM E1409. Test method for determination of oxygen and nitrogen in titanium and titanium alloys by Inert gas fusion.</li> <li>- ASTM E1447. Test method for determination of hydrogen in titanium and titanium alloys by inert gas fusion thermal conductivity/infrared detection method</li> </ul> |
| Flow Rate               | <ul style="list-style-type: none"> <li>- ASTM B213. Test method for flow rate of metal powders using the hall flow-meter funnel.</li> </ul>   |
| Apparent Density        | <ul style="list-style-type: none"> <li>- ASTM B212. Test Method for Apparent Density of Free-Flowing Metal Powders Using the Hall Flow-meter Funnel.</li> </ul>   |
| Powder Morphology (SEM) | <ul style="list-style-type: none"> <li>- ASTM B243. Terminology of Powder Metallurgy</li> </ul>   |
| Powder Cross-section    | <ul style="list-style-type: none"> <li>- ASTM E3. Guide for Preparation of Metallographic Specimens.</li> <li>- ASTM E407. Practice for Micro-etching Metals and Alloys<br/>Note: It is very important to test the initial microstructure of the powder and verify that there is not gas inside the powder particles due to the method to obtain the powder.</li> </ul>   |
| Particle Size           | <ul style="list-style-type: none"> <li>- ASTM B822. Test Method for Particle Size Distribution of</li> </ul>  |

|              |  |
|--------------|--|
| Distribution | Metal Powders and Related Compounds by Light Scattering. |
|--------------|--|

Study 2: Correlation between powder and bulk material in terms of chemical composition.

Study 1 is based on powder characterization, but Study 2 characterizes the chemical composition of the bulk material. The chemical composition mentioned in the standard ASTM F2924 refers to the processed material. [101]

In addition, if it is possible to know about the correlation, in terms of chemical composition, between the powder and the bulk material, powder recyclability will be characterised.

For chemical analysis, spherical samples will be built (see Section 5.2.5).

**Table 4-2** describes all the chemical analysis to be characterised.

**Table 4-2** Chemical composition test and standards.

| Test required     | Test Standard   |
|-------------------|---|
| Chemical Analysis | <ul style="list-style-type: none"> <li>- ASTM E2371. Test method for analysis of Titanium and Titanium alloys by direct current plasma and inductively coupled Plasma atomic emission spectrometry.</li> <li>- ASTM E1409. Test method for determination of Oxygen and Nitrogen in titanium and titanium alloys by Inert gas fusion.</li> <li>- ASTM E1447. Test method for determination of Hydrogen in titanium and titanium alloys by inert gas Fusion thermal conductivity/infrared detection method</li> </ul> |

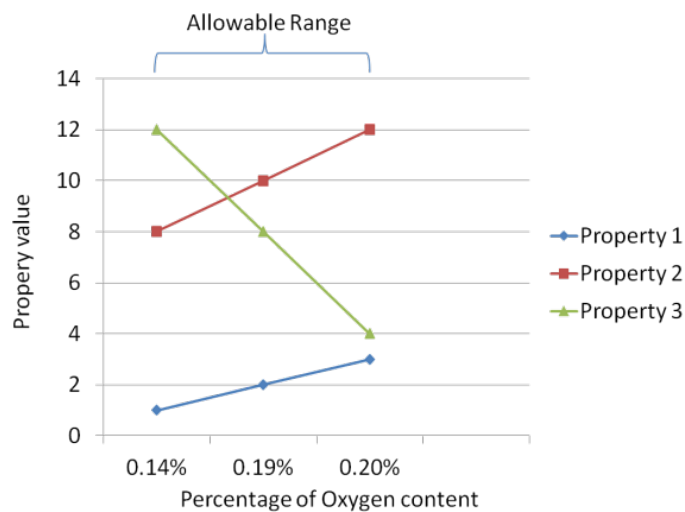
Study 3: Bulk material characterisation into the key factors limits.

The aim of this study is to establish the behaviour of AM parts within the specified limits of the material. In the case, of Ti6Al4V, the oxygen content is the criterion to distinguish between grade 5 (0,20% oxygen content) for aircraft application and ELI or grade 23 (0,13% oxygen content) for health device

application. Therefore, the oxygen content delimits the boundaries to be in compliance with material standards. In other words, oxygen content defines the allowance range of the bulk material.

For example, in the case of EBM the material provider gives the material with an approximate percentage of 0.14% oxygen content and the material standard (ASTM F2924 [101]) sets the maximum limit of the percentage of oxygen content at 0.20%.

With the alloy property characterisation of the bulk material into the oxygen content limits, it is possible to know any alloy property if the oxygen content of the bulk material is inside this range. As is shown in Figure 4-11, any property would be interpolated inside the allowance range.



**Figure 4-11** Ti6Al4V property into the allowance range.

To conclude, Table 4-3 includes all the alloy properties to be characterised into the allowance range.

**Table 4-3** Bulk material tests and standards.

| <b>Test Required</b>   | <b>Test Standard</b>   |
|--|--|
| Chemical Analysis  | <ul style="list-style-type: none"> <li>- ASTM E2371. Test method for analysis of Titanium and Titanium alloys by direct current plasma and inductively coupled Plasma atomic emission spectrometry.</li> <li>- ASTM E1409. Test method for determination of oxygen and Nitrogen in titanium and titanium alloys by Inert gas fusion.</li> <li>- ASTM E1941. Test method for determination of Carbon in Refractory and reactive metals and their alloys by combustion analysis.</li> <li>- ASTM E1447. Test method for determination of Hydrogen in titanium and titanium alloys by inert gas Fusion thermal conductivity/infrared detection method.</li> <li>- EN 3976. Aerospace series. Titanium and titanium alloys. Test method. Chemical analysis for the determination of hydrogen content.</li> </ul> |
| Microstructure – Sample Preparation, Porosity, Grain Size, Surface contamination | <ul style="list-style-type: none"> <li>- ASTM E3. Guide for Preparation of Metallographic Specimens.</li> <li>- ASTM E407. Practice for Micro-etching Metals and Alloys</li> <li>- ASTM E112. Test Methods for Determining Grain Size</li> <li>- EN2003-4. Aerospace series- Test methods- Titanium and titanium alloys- Part 009: Determination of surface contamination.</li> </ul>  |
| Tensile Sample Preparation and   | <ul style="list-style-type: none"> <li>- ASTM E8M. Test Methods for Tension Testing of Metallic Materials</li> </ul>   |



|              |   |
|--------------|---|
| Test         | - ISO 6892. Metallic materials - Tensile testing - Part 1: Method of test at room temperature.  |
| Fatigue Test | <ul style="list-style-type: none"> <li>- ASTM E 466 (high-cycle fatigue): Standard Practice for Conducting Force Controlled Constant Amplitude Axial Fatigue Tests of Metallic Materials</li> <li>- ASTM E 606 (low-cycle fatigue): Standard Practice for Strain-Controlled Fatigue Testing.</li> <li>- ASTM E 647 (fatigue crack growth): Standard Test Method for Measurement of Fatigue Crack Growth Rates.</li> </ul> |

Study 4: Influence of the HIP process on microstructure and tensile properties

Taking into consideration the high technical specification from the aerospace sector, final components will be subjected to heat treatments and Hot Isotactic Pressing (HIP) to release internal stresses, improve the mechanical properties and avoid fatigue issues. The HIP process on AM parts is essential to reduce levels of porosity.

HIP is a heat treatment that permits control and optimization of the  $\alpha$  phase morphology, due to the specific microstructure resulting from this process which contains columnar grains of prior  $\beta$  phase growing along the build direction and Widmanstätten  $\alpha$  platelets (see Section 2.4). In general, the size of  $\alpha$ -platelets colony is very small and in the majority of cases they are present in singular forms. HIP treatment modifies the microstructure and reduces slightly the static mechanical properties of the material. The final microstructure needs to be characterised within the region of interest in the part following a predefined procedure defined in an approved standard.

- ASTM3: Guide for Preparation of Metallographic Specimens.
- ASTM E407: Practice for Micro-etching Metals and Alloys.
- ASTM E112: Test Methods for Determining Grain Size.
- EN2003-4: To Characterise Surface Contamination.

It is important to highlight the fact that during the AM process, the part suffers high cooling rates and multiple thermal cycles that affects the morphology of the microstructure. This results in different microstructure in the building direction (from the top to the bottom). Bigger grain sizes and thicker alpha phase microstructure at the bottom of the building platform, and small grain sizes and thinner alpha phase microstructure at the top of the building platform.

The aim of this study is to know the influence of the HIP treatment on the microstructure and the tensile strength of Ti6Al4V. In addition, the powder bed location and build orientation of the witness specimens would be considered.

#### *Study 5: Influence of the roughness and HIP process in the fatigue test*

Good fatigue behaviour is required for aircraft components. The porosity and the roughness typical of AM processes are a risk for fatigue performance.

In order to improve the Ti6Al4V “Boeing” bracket fatigue behaviour, HIP will be applied on the part. It will reduce the porosity level, which reduces the fatigue life of the component.

A high value of roughness allows a stress concentration on the surface of the part. It may result in a crack nucleation. Roughness is more critical than porosity in the fatigue behaviour of the part, because it accelerates the crack initiation (see Section 2.4.3). Processes like machining or polishing can reduce the roughness and therefore improve the fatigue properties of the part.

The aim of this study is to determine the influence on fatigue resistance of these treatments in combination or separately. In addition, powder bed location and build orientation of the testing parts would be considered.

### Study 6. Demo part validation

The aim of this study is to validate a demonstration part process by AM. To evaluate the conformity of the part, some assessments should be considered including:

- Chemical composition.
- Dimensional analysis.
- Visual inspection.
- NDT:
  - Computerised Tomography (CT) scan: It can be used to detect deep or embedded defects (like lack of fusion, porosity, or density of inclusions) and confirm the effectiveness of thermal post-processes like HIP. It is also useful to validate internal measurements and tolerances on the part without destroying it. The main disadvantage of this technique is that it cannot detect defects smaller than around 27 microns.
  - Dye-penetrant inspection. The roughness presented in AM manufactured parts is around the characteristic size of the powder (20-60 microns). This irregular surfaces make the detection of surface defects difficult or impossible (like micro-cracks).
  - Structured light: One of the challenges encountered in AM is maintaining dimensional accuracy of precision parts that must be made to close design tolerances. Non-contact NDE metrology methods using structured (laser/white) light can be used to monitor build accuracy during processing, or measure finished part dimensional accuracy and tolerances after processing.
- Mechanical tests to assess the mechanical properties and behaviour of the bracket.

Appropriate NDT are needed before, during, and after the AM production process for validation and verification purposes. Traditionally, metal parts have been inspected using ultrasonic, X-rays, dry-penetrant, and magnetic particles techniques amongst others. However, these techniques cannot cope with the

complex geometries normally produced by AM. Current NDT techniques are not optimised for AM processes, materials and parts.

The STM Committee E07 are currently working in a new standard for NDT on AM parts named “Standard Guide for Non-destructive Testing on Additive Manufactured Parts Used in Aerospace Applications”.<sup>22</sup>

This standard will be focused on mature materials (like Ti6Al4V) and AM processes (EBM or SLM). The NDT that will be considered are: CT (finished metal part), Thermography Testing (finished and in-situ process), and Structured Light (finished part).

#### Study 7. Process reproducibility

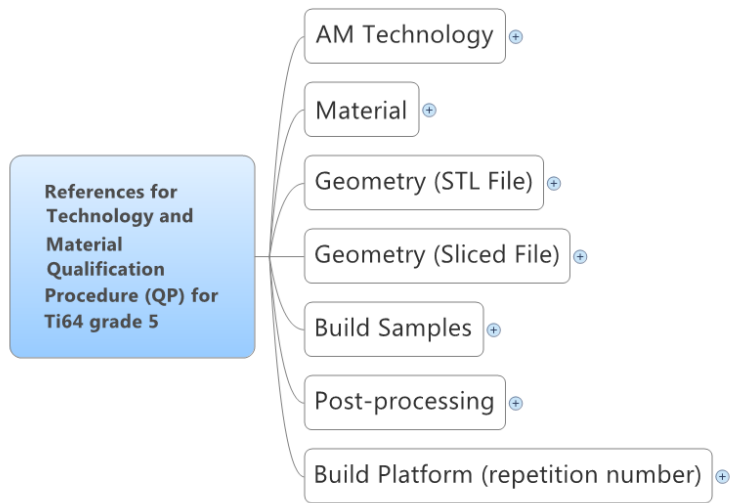
Once prior studies have been done, and the process is specified, well-characterised and understood, it is necessary to demonstrate the invariability of the manufacturing process. In other words, if the manufacturing process is invariable, predictable, and controllable, the specified process will be reproducible amongst different manufacturing batches.

A comparison of all results must be done to evaluate the reproducibility of the process and to conclude the feasibility of the developed QP (see 4.3).

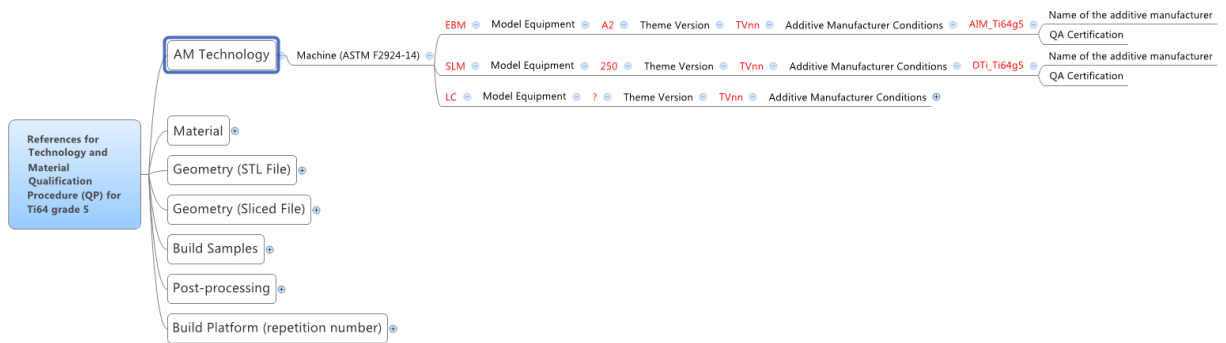
During QP, traceability shall be guaranteed. All steps must be identified from the start to the final parts. All aspects like geometry (files, sliced files), powder batch, type of samples, parts, post-processes, and testing laboratory facilities. All these important data must be stored with a correct nomenclature. The following criterion has been defined to describe this information from any step through the QP (see Figure 4-12, Figure 4-13, Figure 4-14, Figure 4-15, Figure 4-16, Figure 4-17, Figure 4-18, and Figure 4-19).

---

<sup>22</sup> ASTM WK47031. <http://www.astm.org/WorkItems/WK47031.htm> (Accessed on 12/16/2015)



**Figure 4-12** References for Technology and Material Qualification Procedure (QP) for Ti64 grade 5.



**Figure 4-13** References for “AM Technology”.

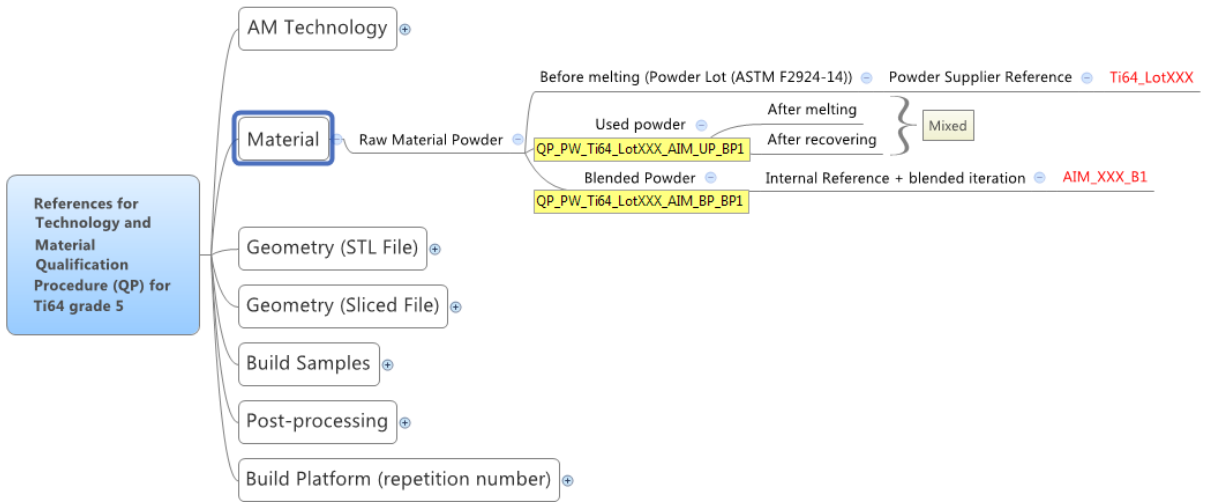


Figure 4-14 References for “Material”.

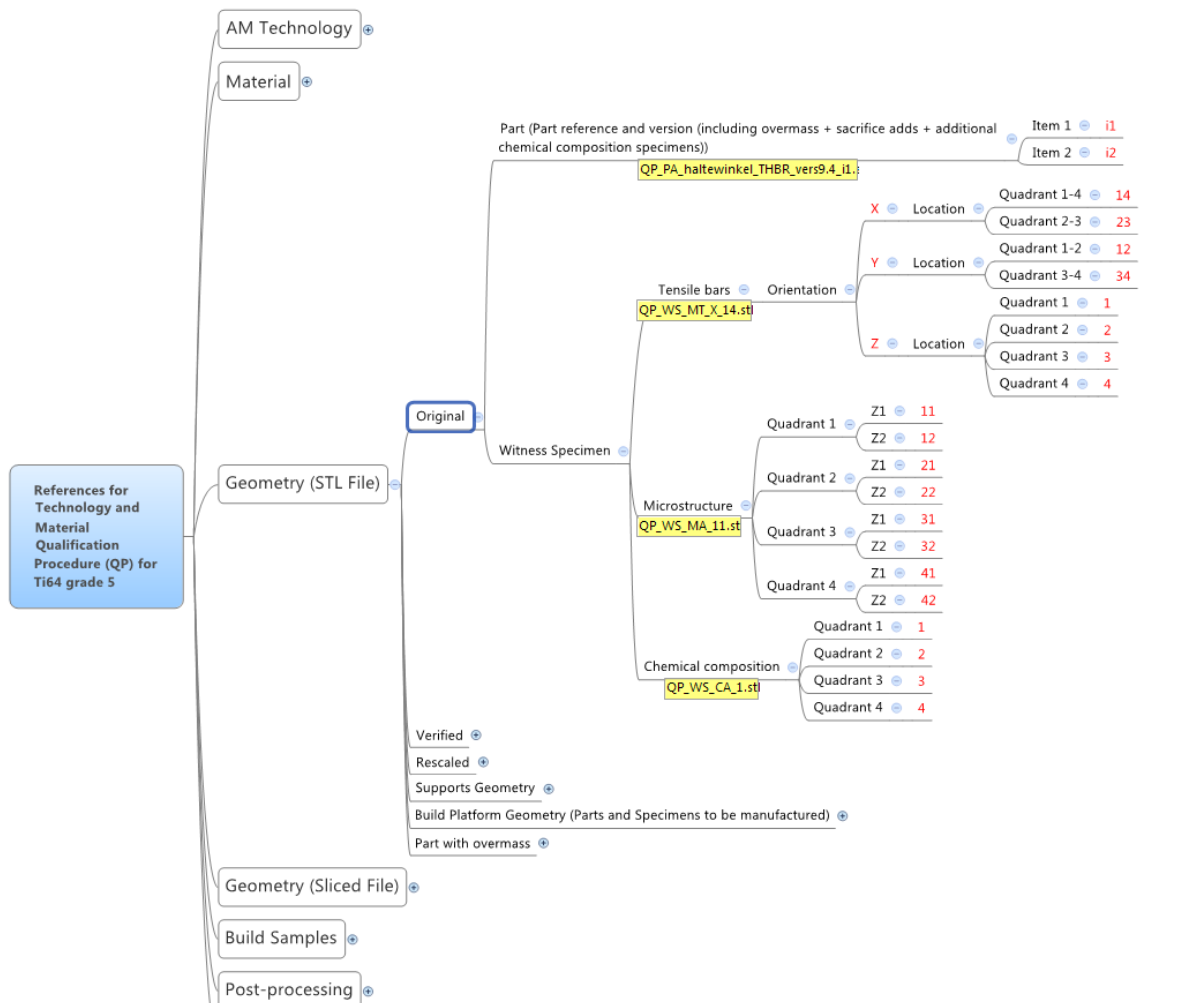
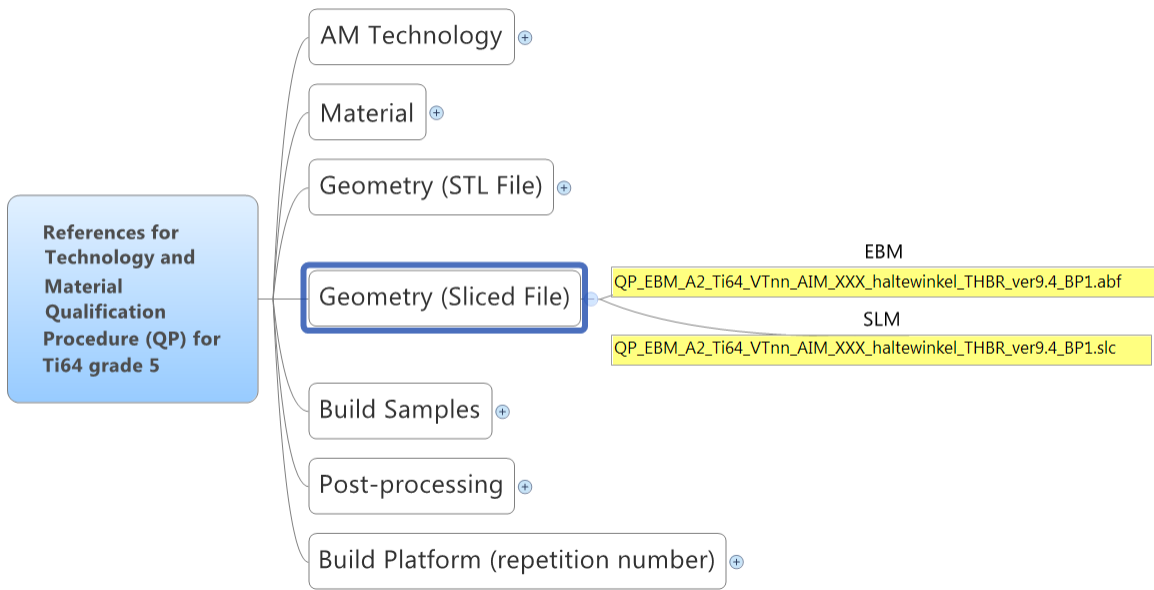
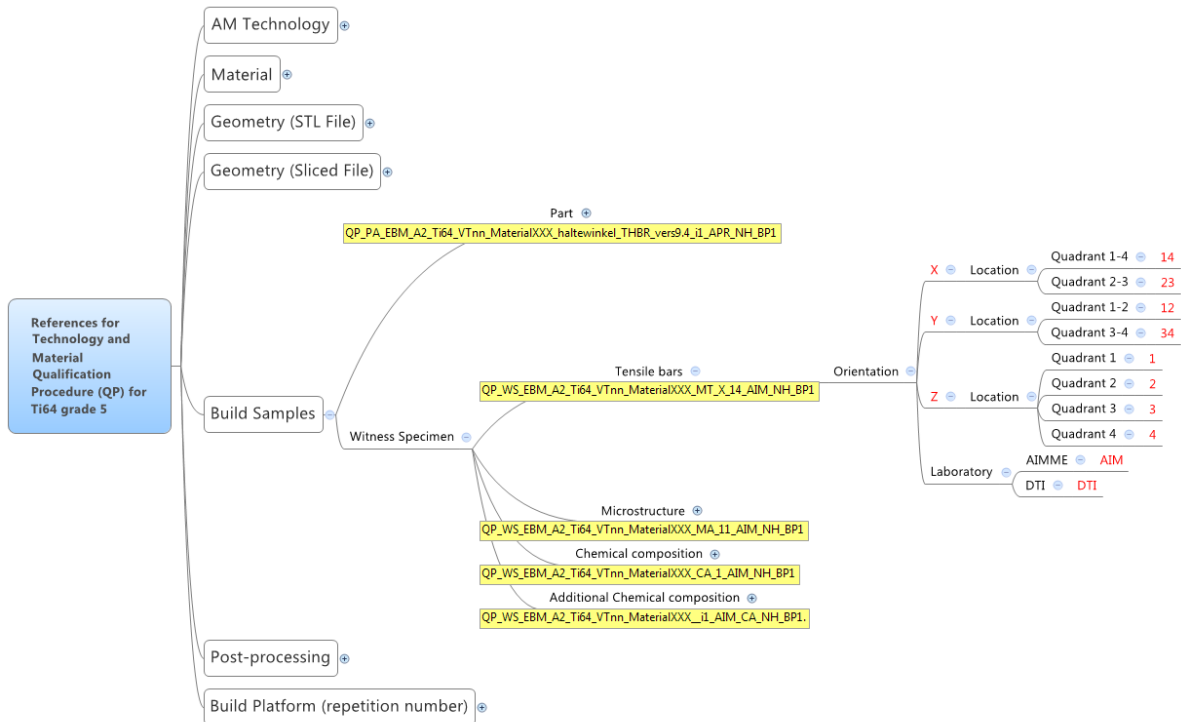


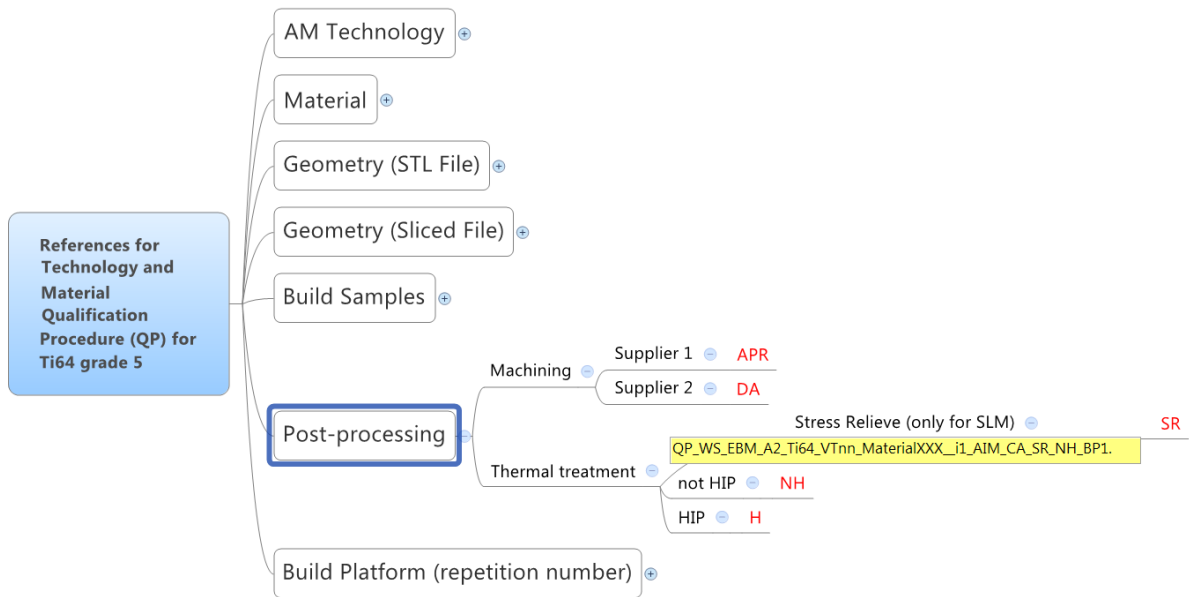
Figure 4-15 References for “Geometry”, specific “Original files”.



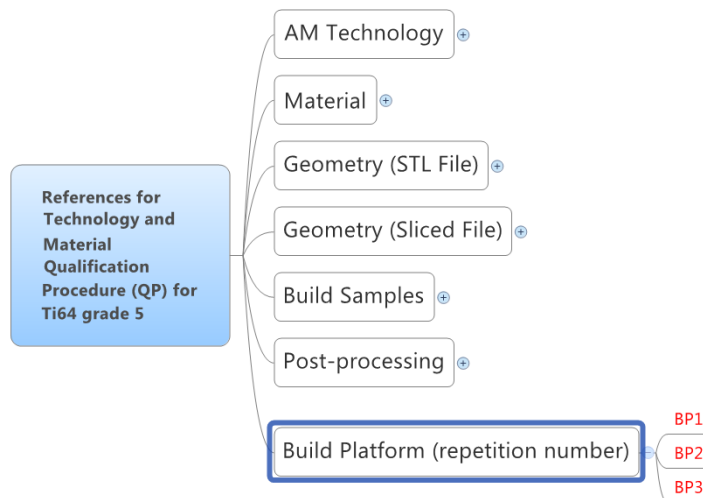
**Figure 4-16** References for “Geometry (Sliced file)”.



**Figure 4-17** References for “Build Samples”.



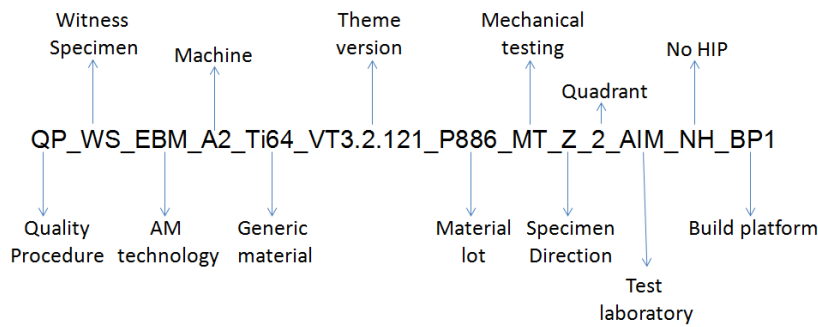
**Figure 4-18** References for “Post-processing”.



**Figure 4-19** References for “Build Platform (repetition number)”.

As an example, the following code represents a mechanical sample test that has been made with EBM, Ti64, and without HIP (see Figure 4-20). As it can be seen, all relevant manufacturing parameters and post-processes can be identified. However, the code is quite long in terms of characters. To simplify this situation, the use of QR labels has been proposed.





**Figure 4-20** References example.

An example of this idea is represented in Figure 4-21.



**Figure 4-21** QR Code example.

At the end of this study, a QA/QM system will be developed, including general procedures (see Chapter 4), operational instructions and validation procedures for the next AM production. Moreover, for each detected key factor, a monitoring procedure must be defined to control them.

The following last two studies are specific for AM repairing processes:

*Study 8. Material interface analysis*

Before repairing a part with AM technologies, it is essential to know if the AM material is compatible with the base material of the original part. For this reason, it is important to select good weld-ability AM material with the part base material.

Test samples shall be built following the repairing conditions, in order to have a macroscopic and microscopic characterization similar to the failed part.

After reviewed all AM standards and due to the lack of specific procedures for these technologies, it has been concluded that the best way to evaluate the level of interface imperfections is applying the following welding standards.

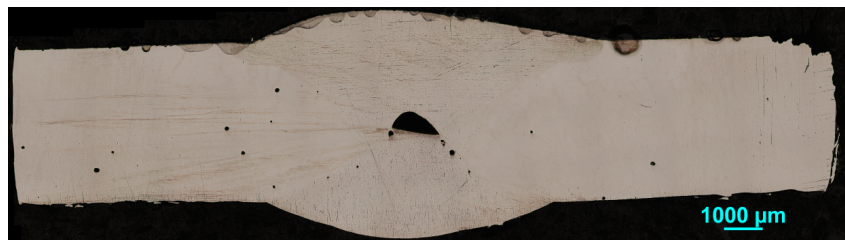
- “ISO 5817: *Welding - Fusion-welded joints in steel, nickel, titanium and their alloys (beam welding excluded) - Quality levels for imperfections,*”

The same situation has been presented for mechanical testing. From this point of view, and due to the particularities of AM, the standard that have been selected is:

- ISO 9015-1: “*Destructive tests on welds in metallic materials - Hardness testing - Part 1: Hardness test on arc welded joints*”.

Internal porosity shall be detected with different transversal cuts of the samples. Figure 4-22 shows an example of internal porosity.

The aim of this study is the assessment of the AM material that fits better with a specific based material, and to obtain optimal AM process parameters to achieve the best joining possible.



**Figure 4-22** Example of internal defects in a conventional welding.

#### Study 9. Machining the part and surface preparation

For AM repair, it is necessary to control the position of the failed part in the platform and to have good surface preparation of the part to ensure good joining with AM.



the BOE bracket and for developing the AM Technology/Material qualification procedure for AM manufacturing (see Table 4-4)

**Table 4-4** BOE bracket process specifications.<sup>23</sup>

| Category      | No. | Information needed                                  | Comments  |
|---------------|-----|---|---|
| Geometry      | 1.1 | Initial 3D Geometry (CAD-File)                      | <a href="#">04_ST_Results/02_WP2/14_PartSelection/PartInformation/BOE-Bracket/</a>  |
|               | 1.2 | Weight  |   |
|               | 1.3 | Measures (and maximum size of parts)                | 173.9 x 109.4 x 37.67 mm (see 3.1)<br><a href="#">04_ST_Results/02_WP2/14_PartSelection/PartInformation/BOE-Bracket/</a>                                    |
| Requirements  | 2.1 | Load conditions                                     |   |
|               | 2.2 | Technical requirements (Form/fit/function/ fatigue) |   |
|               | 2.3 | Part tolerances                                     | ±0.010 in (0.254 mm)  |
|               | 2.4 | Surface finishing                                   | 125 µin (3.175 µm)  |
|               | 2.5 | Electrical conductivity                             | No requirement  |
| Failure Modes | 3.1 | Failure mode information                            | Possible failure modes: <ul style="list-style-type: none"> <li>• Bending overload failure</li> <li>• Fatigue failure</li> <li>• Creep distortion</li> </ul> |

<sup>23</sup> Not all the information has been recorded due to the confidentiality of the stakeholder's information.

| Category    | No. | Information needed  | Comments   |
|-------------|-----|---|--|
|             | 3.2 | What is the relative frequency of the failure mode chosen compared to other failure modes suffered by the part? | The failures are infrequent. However the relative frequency of failure would be <ul style="list-style-type: none"> <li>• Bending overload failure – 69%</li> <li>• Bending fatigue failure – 23%</li> <li>• Creep distortion – 8%</li> </ul> |
|             | 3.3 | Is the part likely to fail/degrade due to some other part failing or degrading?                                 | Not likely   |
|             | 3.4 | Mean Time Between Failures  | Approximately 10 years   |
|             | 3.5 | Failure Location on Part  |  |
|             | 3.6 | Mean Time To Repair/Replace   | 1 month  |
| Application | 4.1 | What is the part used for?  |  |
|             | 4.2 | Part environment (chemical)   | Ambient air  |
|             | 4.3 | Part environment (technical)  |  |
|             | 4.4 | Temperature range   | -50°C to 100°C   |
|             | 4.4 | Configuration of the part within the system to which it belongs   |  |
|             | 4.4 | Interactions with other parts or systems  | Transfer of mechanical loads only. Thermal interaction is not relevant for its function.   |
|             | 4.5 | Pressures (range)   | 760 torr   |
|             | 4.6 | Humidity (range)  | 0% to 65% RH   |
| Others      | 5.1 | How is a part identified?   | Marking on packaging only identifies the part number and requisition number; permanent marking on part would be advantageous   |

| Category          | No. | Information needed   | Comments  |
|-------------------|-----|--|---|
|                   | 5.2 | Are special clamping devices needed during production?   | No.   |
| Material          | 6.1 | Material Data  | Ti-6Al-4V, annealed bar (data from MMPDS-06 for AMS 4928)   |
|                   | 6.2 | Mechanical properties  | Yield strength: 114 ksi (786 MPa)<br>Ultimate strength: 125 ksi (862 MPa)<br>Elongation 8%<br>Reduction in area: 15%<br>Modulus of elasticity: 16.9 Msi (117 GPa) |
|                   | 6.3 | Hardness   |   |
|                   | 6.4 | Fatigue properties   | Log $N_f = 19.18 - 7.55 \log S_{max}$ ; ( $S_{mean} = 0$ ksi)<br>Log $N_f = 7.08 - 2.18 \log S_{max}$ ; ( $S_{mean} = 70$ ksi)                                    |
| Economic measures | 7.1 | Economic goal  |   |
|                   | 7.2 | Current manufacturing process (involved processes, including process parameters, and order of processes) | Direct machining from annealed bar stock  |
|                   | 7.3 | Current part costs   | ~ €1800   |
|                   | 7.4 | Supply chain of the part   |   |
|                   | 7.5 | Production targets   |   |
|                   | 7.6 | Batch size (primary equipment)   |   |
|                   | 7.7 | Batch size (spare parts)   |   |

| Category          | No.  | Information needed  | Comments           |
|-------------------|------|---|--------------------|
|                   | 7.8  | Current repair process (involved processes, including process parameters, and order of processes)                       | Scrap and replace. |
|                   | 7.9  | Current price for repaired part   | N/A                |
|                   | 7.10 | Mean Time To Repair/Replace   | N/A                |
|                   | 7.11 | Mean Time To Diagnose   |                    |
|                   | 7.12 | Average Repair Team Size  |                    |
|                   | 7.13 | Average Technical Delay   |                    |
|                   | 7.14 | Average Logistic Delay  |                    |
|                   | 7.15 | Average Administrative Delay  |                    |
| Health Monitoring | 8.1  | Are there sensors mounted on the part?  | No                 |
|                   | 8.2  | Are there sensors placed near by the part?  | No                 |
|                   | 8.3  | Are there sensors monitoring other parts of the same system? (e.g.: flow and pressure sensors in the hydraulic system)? |                    |
|                   | 8.4  | Current health monitoring data  | N/A                |
|                   | 8.5  | Vibration profile   |                    |
| Sensors           | 9.1  | Location and position   |                    |
|                   | 9.2  | Sample Rate / Precision   |                    |
|                   | 9.3  | Accuracy  |                    |
|                   | 9.4  | Range   |                    |
|                   | 9.5  | Which system(s) have access to the data produced by this sensor?  |                    |

#### **4.4.1.3 QP Process for BOE Bracket**

AM technology/material qualification for the aircraft sector is the ability to meet all the part specifications. Each aspect of its value stream should be verified as sufficient and repeatable.

This Qualification Procedure is based on the standard ASTM 2924-14 “Standard Specification for Additive Manufacturing Titanium-6 Aluminum-4 Vanadium with Powder Bed Fusion” and the knowledge of the AM technology developers and AM users.

This Qualification Procedure was developed building the BOE Bracket in two different AM technologies SLM and EBM. First of all, process specifications were analysed for the supply chain definition. The AM process parameters have been identified and shall be registered due to the final behaviour of the part. A qualification platform for AM building was designed in accordance with Chapter 4. It contains two BOE brackets and different test samples. In order to ensure repetitiveness of the AM technologies (SLM and EBM) it shall be necessary to build the same platform at least three times and compare their results (24 mechanical witness specimens). As it has mentioned before, due to the technical requirements specified by the OEM (see Table 4-4), the qualification building platform has to demonstrate that the final mechanical properties of the part are in accordance with the specified data. In comparison with other manufacturing methods, like forging or casting, AM parts can exhibit, if they are not heat treated, different mechanical properties in different regions and directions but not comparable to those present in composites. This is due to the fact that cooling rates and temperature gradients change during the building process at each point. Having said that, the microstructure is not going to be the same from the bottom to the top of the building platform. Properties like the elongation, the ultimate tensile strength and the yield strength would not be the same through the part.

To evaluate this situation, the tensile witness samples have been positioned at the worst case scenario, which means on the building platform's edges.



In order to do a statistical analysis of the resulting properties, three building platform need to be manufactured. This allows collecting enough data to know if the process is under statistical control. The variability of the resulting mechanical properties will be characterised under the B-basis criteria because if the part fails, the load will be distributed by other structural elements.<sup>24</sup>.

After HIP, the microstructure will be different and more uniform through the part. This will make its mechanical properties homogenous through the specimens. Therefore, the statistical analysis over the HIP processed specimens will be done taking into account the total number of them, 24.

In order to estimate the correspondent probability distribution function (pdf) for each parameter, the following step have been done:

1. Built a hypothesis about the possible pdf. It will be called the null hypothesis (H0).
2. Estimate the correspondent parameters making maximum the log-likelihood of the observed data. Basically, it calculates the distribution parameters that makes the observed data the “most probable”. Based on the null hypothesis, a family of pdf can be defined as a function of its parameter.

For example, it can be considered that the data follows a normal distribution  $N(\mu, \sigma)$  in which the case the parameter will be the vector  $\vec{\theta} \equiv (\mu, \sigma)$ . Given a set of observed values  $(X_1, X_2, X_3, \dots, X_n)$ , the relative probability of observe that data will be:

$$\phi(\mu, \sigma) = f(X_1 | (\mu, \sigma)) \cdot f(X_2 | (\mu, \sigma)) \cdot f(X_3 | (\mu, \sigma)) \dots f(X_n | (\mu, \sigma))$$

$$\phi(\mu, \sigma) = \prod_{i=1}^n \frac{1}{\sqrt{2\pi}\sigma} e^{-\left(\frac{X_i - \mu}{\sigma}\right)^2}$$

---

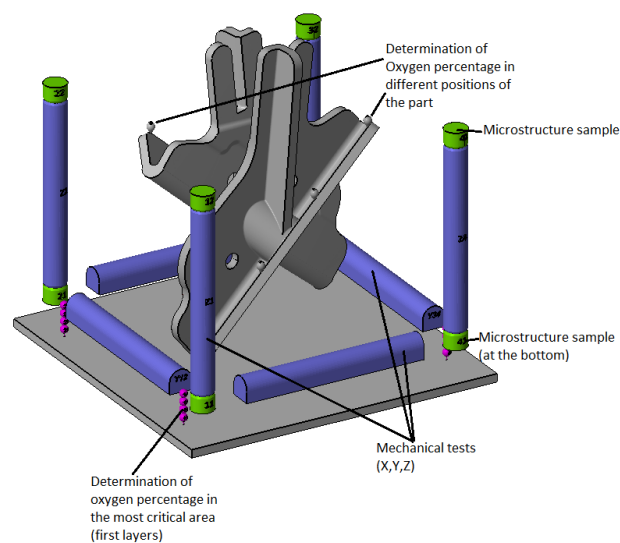
<sup>24</sup> There are two particular tolerance intervals that are widely used in the aerospace industry. These are the A- and B-basis tolerance intervals. The A-basis value of a random variable is such that 99 % of the data will fall above the basis value with a 95 % of confidence. The B-basis is less restrictive, demanding that only 90 % of the data has to be higher than the basis value, again with 95 % of confidence

Maximizing the function  $\phi$  (likelihood function) is equivalent to maximizing the function  $\log(\phi)$  (log-likelihood function). The calculated parameters values are for this example:

$$\hat{\mu} = \frac{\sum_{i=1}^n X_i}{n} \quad \hat{\sigma} = \sqrt{\frac{\sum_{i=1}^n (X_i - \hat{\mu})^2}{n}}$$

3. Goodness of fit test. After fitting data with one or more models, it is necessary to evaluate the goodness of the initial hypothesis. In other words, how close are the observed values to those which would be expected. The test evaluates the null hypotheses (H0) against the alternative (data are not drawn from the assumed distribution). It is necessary to specify a level of significance for the test. Due to the number of samples, it has been considered a default significance level of 5%. Two different Goodness of fit test will be carried out.
  - a. Kolmogorov-Smirnov goodness of fit test. The Kolmogorov-Smirnov test is a nonparametric test of the null hypothesis which compares the population to the hypothesised cumulative distribution function (cdf).
  - b. Lilliefors goodness of fit test: It can be used to test whether the data vector  $x$  has a lognormal or Weibull distribution by applying a transformation to the data vector. To test  $x$  for a Weibull distribution, test if  $\log(x)$  has an extreme value distribution.

Figure 4-24 shows the designed QP build platform. It includes the following samples:



**Figure 4-24** Technology/material qualification platform configuration.

- RAW MATERIAL: Evaluation of the chemical composition of the powder before and after building. Moreover, for non-dedicated machine it is necessary to check possible impurities in the powder.
- PARTS: Two Boeing brackets. The reason for including two brackets is to take into account the machining of the parts.
- TEST SAMPLES:
  - Chemical composition in the bulk material (as mentioned in ASTM 2924).
    - An ARCAM internal document shows the effects of the oxygen pick-up in the Ti6Al4V EBM process and the differences depending on the height.
    - For these reasons, for EBM technology it is essential to control the percentage of oxygen of the melted material. Moreover, it shall be studied the content of oxygen in the first layers of the platform and controlled the percentage of the oxygen in different positions of the parts (see the small samples as balls joining the part) to ensure the quality of the material of the bracket.
    - 4 samples are included for mechanical testing purpose at different z-levels.
    - Moreover, supports shall be used to detect all elements of the alloy in the bulk material and to detect possible impurities.
  - Mechanical properties:
    - Various studies by ARCAM have concluded that impurities are present in the part at the first layers of a building. Thus, separating the parts from the platform and placing supports are recommended.
    - An ARCAM internal document shows that the mechanical properties of parts are not dependent on the position in the platform.

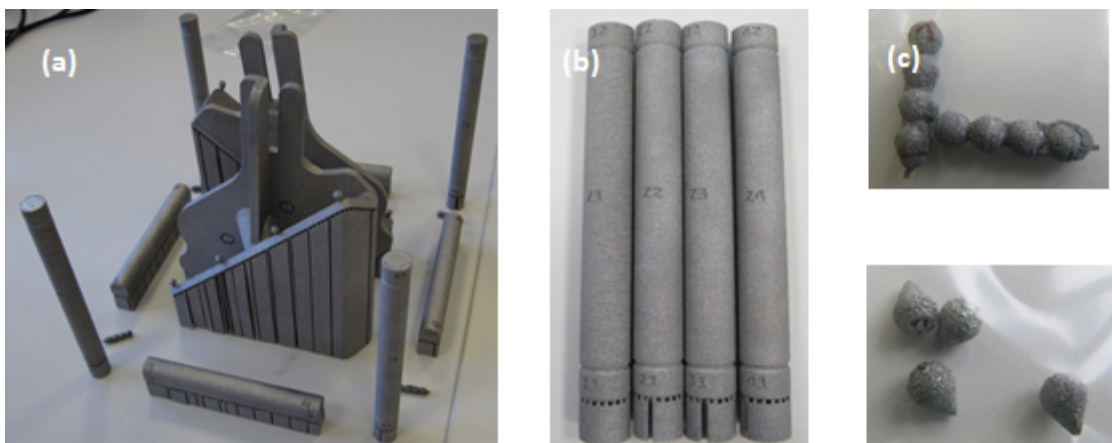
- For these reasons parts will be located at  $z=15\text{mm}$ . The value of  $z=15\text{ mm}$  is a safety margin. Typically it would be less, but this value should be determined by this test.
- 4 tensile specimens in each orientation are included to have a statistical number of samples to perform tests.
- Microstructure test: It characterizes how the microstructure changes with the platform position.

As was set up in the supply chain, parts shall be HIP-treated to improve fatigue behaviour. For this reason, test samples (except chemical composition samples) shall be HIP treated as well in order to obtain similar final part's properties (mechanical behaviour and the microstructure).

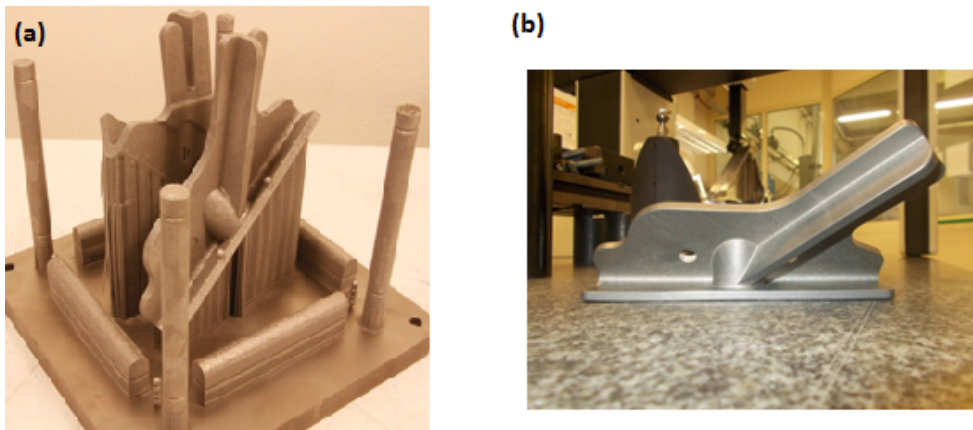
Currently, the first build platform has been built in SLM and EBM.

During the first build platform, some problems with supports and over-machining were encountered and some modifications need to be made for the next build platforms.

Figure 4-25 and Figure 4-26 show the results of the first build platform for EBM and SLM respectively.



**Figure 4-25** (a) EBM building platform 1. (b) Tensile “z” and microstructure witness specimens. (c) Chemical composition witness specimens.



**Figure 4-26** (a) SLM building platform 1. (b) “Bracket” machined.

The support structure of the bracket was not big enough to retain all internal stresses.

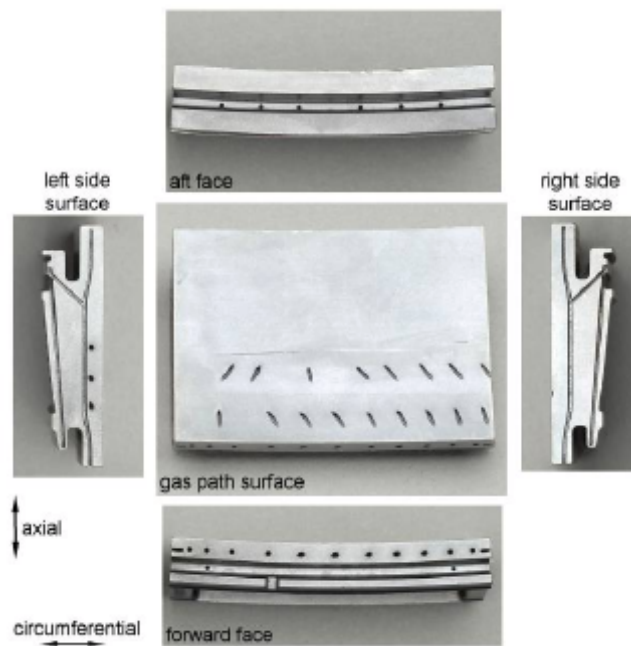
#### **4.4.2 CFM56 2/3 HTP shroud**

##### **4.4.2.1 Definition**

High pressure turbine (HPT) shrouds, which are used to minimize the leakage of air around the turbine blade tips, are valuable components in aero-engines and industrial gas turbines (IGTs) to improve engine efficiency and performance. The shrouds can be of various designs and be produced with various materials, depending on the engine type and the engine original equipment manufacturer (OEM).

The Case Study is concerned with the HPT shrouds that are used in the CFM56-2/3. For these engines, Lufthansa Technik carries out the repair operation to the maintenance shops of airliners as an alternative to the parts delivered by the OEM.

An example of such a HPT shroud is shown in Figure 4-27. Each shroud is made of solid metal and contains a smooth gas path surface. During engine operation, the hot gasses pass over this surface along the axial direction from the forward to the aft side of the shroud. Simultaneously, the turbine blade tips pass the shroud’s surface along the circumferential direction.



**Figure 4-27** HTP shroud.

Each turbine stage contains a multiple amount of these shrouds (the exact number depends on the engine type), which are placed side by side along the circumferential direction to form a complete sealing ring. Most of the shrouds contain cooling holes to provide film cooling at the shroud's gas path surface. The location and amount of these cooling holes are considered important design parameters to control the temperature and stress distribution in the shrouds during engine operation.


During engine operation, the HPT shrouds are exposed to very high temperatures and aggressive environments. In addition, the blade tips may contact the shroud gas path surface (e.g. during a hard landing), a phenomenon further referred to as blade tip-to-shroud rubbing or simply rubbing. Both the exposure to high temperatures and the rubbing events may lead to a severe deterioration of the shroud up to the point where the airliners have to remove the shrouds from the engine in order to replace or repair them.

### 4.4.3 Process specifications

At the beginning of this project the process specifications were collected from the corresponding stakeholder. These data were the starting point for repair of the CFM56 -2/3 HPT shroud.

**Table 4-5** HTP data specifications.<sup>25</sup>

| Category | No  | Information needed               | Comments                |
|----------|-----|----------------------------------|-------------------------|
| Geometry | 1.1 | Initial 3D Geometry (CAD-File)   | Available on Sharepoint |
|          | 1.2 | Weight                           |                         |
|          | 1.3 | Measures (and max size of parts) | Available on Sharepoint |

|               |     |   |  |
|---------------|-----|---|--|
| Requirements  | 2.1 | Load conditions                                     |  |
|               | 2.2 | Technical requirements (Form/fit/function/ fatigue) |  |
|               | 2.3 | Part tolerances                                     | See Geometrical Data in Share Point  |
|               | 2.4 | Surface finishing                                   | 250 µin (6.35 µm)  |
|               | 2.5 | Electrical conductivity                             | No requirement   |
| Failure Modes | 3.1 | Failure mode information                            | Rubbing/Hot corrosion<br> |

<sup>25</sup> Not all the information has been recorded due to the confidentiality of the stakeholder's information.

|             |     |  |                                |
|-------------|-----|--|--------------------------------|
|             | 3.2 | What is the relative frequency of the failure mode chosen compared to other failure modes suffered by the part |                                |
|             | 3.3 | Is the part likely to fail/degrade due to some other part failing or degrading?                                |                                |
|             | 3.4 | Mean Time Between Failures   |                                |
|             | 3.5 | Failure Location on Part   | Gas path surface               |
|             | 3.6 | Mean Time To Repair/Replace  | 21 days                        |
| Application | 4.1 | What is the part used for  |                                |
|             | 4.2 | Part environment (chemical)  | Very aggressive                |
|             | 4.3 | Part environment (technical)   |                                |
|             | 4.4 | Temperature range  | Close to 1500 K                |
|             | 4.4 | Configuration of the part within the system to which it belongs  |                                |
|             | 4.4 | Interactions with other parts or systems   |                                |
|             | 4.5 | Pressures (range)  |                                |
|             | 4.6 | Humidity (range)   |                                |
| Others      | 5.1 | How is a part identified   |                                |
|             | 5.2 | Are special clamping devices needed during production?   | Yes                            |
| Material    | 6.1 | Material Data  | Rene N5, Rene N2, and Mar-M509 |
|             | 6.2 | Creep Resistance   | -                              |
|             | 6.3 | Cycle oxidation resistance   | -                              |
|             | 6.4 | Cycle oxidation resistance   | -                              |
|             | 6.5 | Type I hot corrosion resistance  | -                              |



|                   |      |   |  |
|-------------------|------|---|--|
|                   | 6.6  | Microstructure  | A polycrystalline structure in the build-up zone is sufficient |
| Economic measures | 7.1  | Economic goal   |  |
|                   | 7.2  | Current manufacturing Process<br>(involved processes, including process parameters, and order of processes) |  |
|                   | 7.3  | Current part costs  |  |
|                   | 7.4  | Supply chain of the part  |  |
|                   | 7.5  | Production targets  |  |
|                   | 7.6  | Batch size (primary equipment)  |  |
|                   | 7.7  | Batch size (spare parts)  |  |
|                   | 7.8  | Current repair process (involved processes, including process parameters, and order of processes)           |  |
|                   | 7.9  | Current price for repaired part   |  |
|                   | 7.10 | Mean Time To Repair/Replace   |  |
|                   | 7.11 | Mean Time To Diagnose   |  |
|                   | 7.12 | Average Repair Team Size  |  |
|                   | 7.13 | Average Technical Delay   |  |
|                   | 7.14 | Average Logistic Delay  |  |
|                   | 7.15 | Average Administrative Delay  |  |

#### 4.4.3.1 Current HPT repair process.

The current repair process for the HPT shroud is represented in Figure 4-28. All the steps have been studied in order to determine which operations can be substituted by AM.

Then, a prototype for the clamping device was designed to carry out these operations inside the AM machine. However, those samples were not repaired with the proper material approved by the OEM.

From the point of view of the certification process, the best approach would be to study how to use the approved materials with AM machines. Then, optimize the control parameters of the system in order to achieve the desired microstructure and properties. The result of the new repair process with AM steps will constitute a new major repair design.

If the approved material cannot be processed with AM technology, the approval of the new repair design will be more difficult, because it will be necessary to demonstrate that the repaired part in service complies with all the technical requirements.

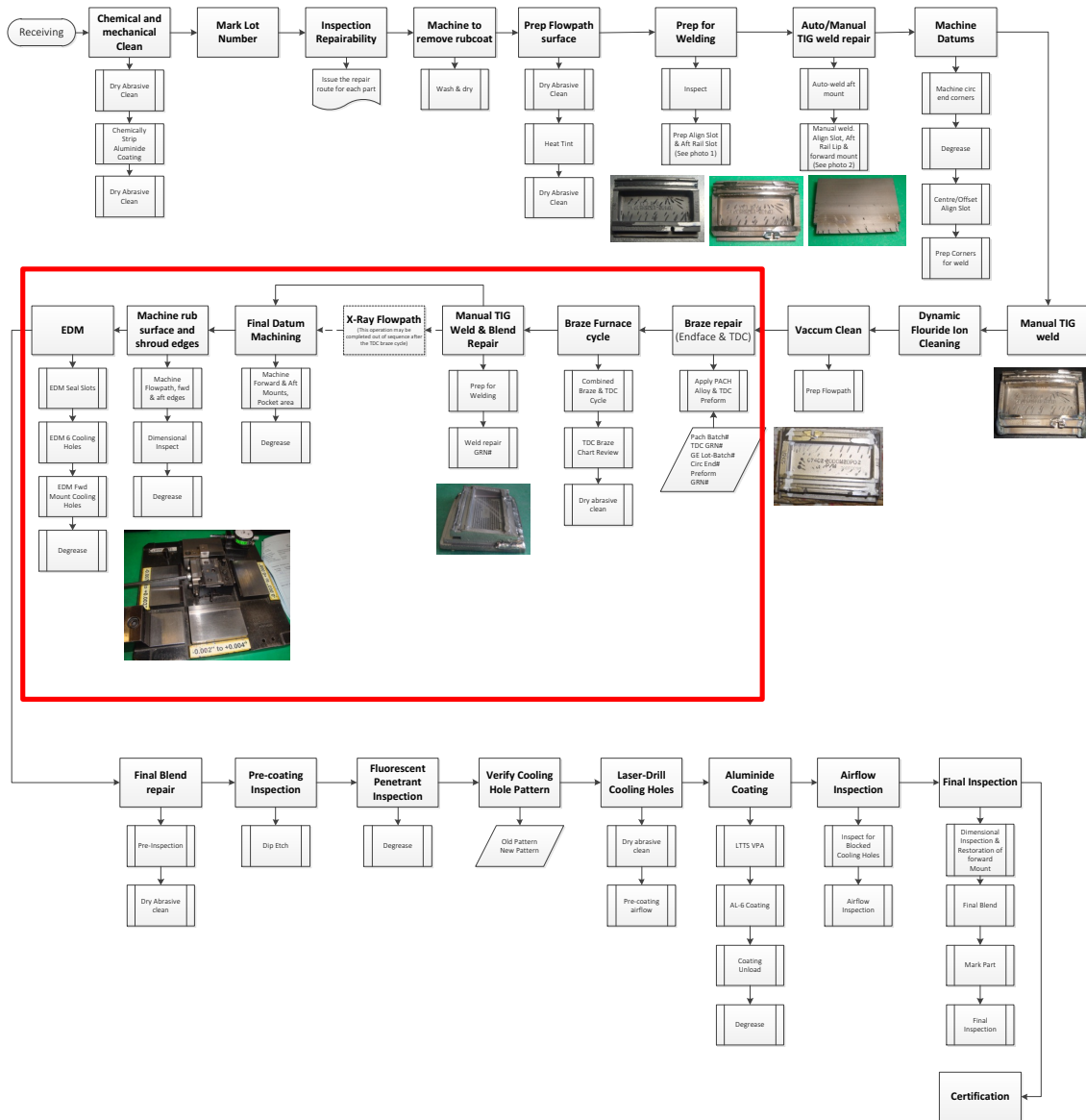


Figure 4-28 Current repair process. All the activities inside the red box will be substituted by AM.

## **5 QA/QC Procedures for EBM and SLM.**

### **5.1 Introduction**

Introducing additive manufacturing systems in the production or repair chain of certain aircraft components requires the approval of the final products. The approval of a product consists of a set of mandatory procedures by which compliances with all the technical specifications, prior to its production and commercialization, is obtained. It is a mechanism against potential effect on the health and safety of people. The approval is thus a quality accreditation mechanism that differs fundamentally from the mandatory certification of the following:

- The Quality Management System (QMS) certification has a voluntary nature (ensures the health and safety of the product)
- The mandatory certification applies when the product must comply with technical specifications established by law or regulation. Instead, the certification refers to the compliance of a standard.

In this chapter, Quality Assurance (QA) procedures for AM using SLM and EBM will be developed and presented in order to ensure the traceability of products and materials and establish good manufacturing practices. These will be part of future QMS of any aerospace company that includes AM in their supply chain.

It is important to note that QA procedures of a company involve many issues related to organisational matters, including audit procedures and management review processes. Therefore, this chapter deals only with procedures affected by using AM in the manufacturing or repair process. These procedures can be categorized into three different groups:

- General Procedures. This group contains procedures related to general issues, including traceability (powder, consumables, and parts), personnel, responsibilities, control of the equipment and quotation management, amongst others, which have to be modified due to peculiarities of EBM and SLM. Most of them can be applied for other AM technologies.

- Operational Instructions. This group contains technical procedures for EBM and SLM to control the process and establish good manufacturing practice to guarantee the quality of the final product.
- Control Procedures. This group contains control procedures for EBM and SLM during the manufacturing process.

Approximately, each procedure has the same content structure:

- Aim, scope, and responsibilities.
- Definition of the involved activities.
- Flowchart of the process.
- Potential risks and their no-quality impact.
- Performance indicator to measure the efficiency of the procedure.
- Registers (see Appendix C).

All these procedures have been written in accordance with ISO 9001:2008 [111], ISO 9000:2005 [112], ISO EN 9100:2010 [113], and EN 9110:2010 [114].

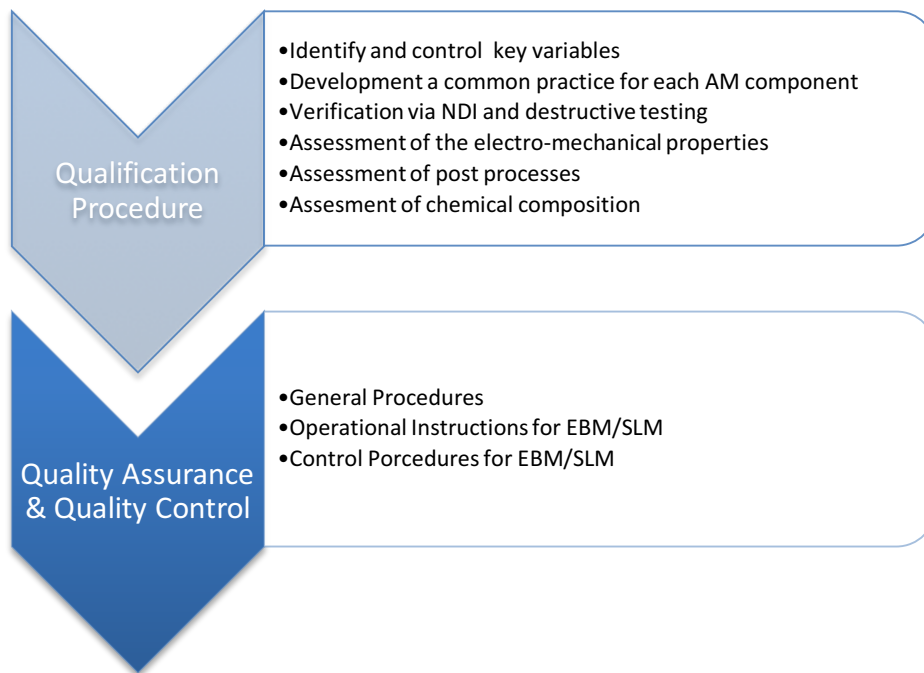
All flowchart diagrams are in compliance with UNE-EN-ISO 10628:2001.

An AM process flowchart for EBM and SLM technologies is represented in Appendix B, which should be accessible during the chapter 5 reading.<sup>26</sup>

Figure 5-1 shows the link between the present chapter and Chapter 4.

---

<sup>26</sup> Due to the complexity of the present chapter, the author recommends reading this chapter and Appendix B at the same time.



**Figure 5-1** Thesis overview.

## **5.2 General QA procedures**

### **5.2.1 Description of responsibilities**

In this section roles of the personnel included in the manufacturing process with EBM/SLM, as well as, their fundamental responsibilities, will be presented. The necessary training needed to carry out their role will be described in order to establish the proper qualification.

This procedure applies to all staff involved in the supply chain of AM parts with EBM/SLM machines. It does not include the staff involved in complementary tasks. Technical roles and responsibilities are described in Table 5-1.

**Table 5-1** Technical roles.<sup>27</sup>

| <b>Definition</b>  | <b>Role</b>  | <b>Responsibilities</b>   |
|--------------------|--|---|
| Technology Manager | It is the maximum responsible of the technology and the process, including post-processes.   | <ul style="list-style-type: none"> <li>○ Validate the quotations and purchase orders.</li> <li>○ Manage the human resources involved in the process.</li> <li>○ Analyse the incidents: machine problems, bottlenecks, non-conformities, etc.</li> <li>○ Make the technical decisions in case of system failure.</li> </ul>  |
| Quotation Agent    | Technician responsible for contact with customers and the preparation of the quotation. He/she is the link between clients and the Process Engineer. | <ul style="list-style-type: none"> <li>○ Analyse the potential customer's needs and evaluate if the final product can be made with EBM/SLM technology.</li> <li>○ Manage all the quotation process -from the first contact with the customer – to the point where the quotation is sent to the customer.</li> <li>○ Manage all the communications with the System Operator and</li> </ul> |

---

<sup>27</sup> Depending on the structure of each organisation the same person could assume more than one role.

|                  |   |  |
|------------------|---|--|
|                  |   | <p>register any incidents.</p> <ul style="list-style-type: none"> <li>○ Send the quotation to the customer and modify the quotation if necessary.</li> <li>○ Manage all communications about incidents during the production of parts and delivery dates</li> <li>○ Analyse technical issues and assist the Technology Manager to make a proper decision.</li> </ul>   |
| Process Engineer | Responsible for the building preparations | <ul style="list-style-type: none"> <li>○ Optimise the building space plate.</li> <li>○ Manage the order of batches in order to optimise shipping times.</li> <li>○ Communicate any issue during the processes to the Technology Manager.</li> <li>○ Order the purchase of consumables and raw materials.</li> <li>○ Control the stock of powder, plates and other machine components, informing the Technology Manager.</li> <li>○ Carry out and schedule the system's principal maintenance according to</li> </ul> |



|                     |   |  |
|---------------------|---|--|
|                     |   | the OEM's guidelines.  |
| Design Engineer     | Responsible for part design for AM, including redesign.             | <ul style="list-style-type: none"> <li>○ Taking into account AM design restrictions before starting the building process.</li> <li>○ Redesign the parts if necessary.</li> </ul>   |
| System Operator     | Technician responsible for the optimum performance of the machine   | <ul style="list-style-type: none"> <li>○ Operate the EBM/SLM.</li> <li>○ Control all the parameters of the machine, informing the Process Engineer and Technology Manager of any incidents.</li> <li>○ Carry out the basic periodical maintenance of the machine.</li> </ul> |
| Material Consultant | The material expert, who has to check the quality of raw materials. | <ul style="list-style-type: none"> <li>○ Validate the quality of fresh powder.</li> <li>○ Control the quality of recycled powder.</li> </ul>   |

Another important aspect is the training requirements and the training planning of the personnel.

The Technology Manager will be responsible for assigning each job profile to competent technicians. Technical requirements and skills for each position will be registered in the *GP6RE01. Training requirement* (see 6.2Appendix C, section 6.2C.1.4).

The necessary training can change depending on technology advances, strategic decisions, etc. It is necessary to establish a training planning each

year. Annually, training needs will be defined in the register *GP6RE02. Training Planning* (see 6.2Appendix C, section C.1.5)

After training, every course will be assessed by the attendant and the technology manager, in order to check if the training action has been effective. For this purpose, the register *GP6RE02. Training Assessment* (see Appendix C, section C.1.6) must be fulfilled.

The potential quality risks that have been identified in this procedure are summarizing in Table 5-2.

**Table 5-2** Potential quality risks associated with procedure 5.2.1.

| <b>Risks</b>                  | <b>Impact</b>  |
|-------------------------------|--|
| Confusion of responsibilities | <p>If responsibilities are not clear, mistakes could happen if any role assumes more (or fewer) tasks.</p> <p>It is very important that all technicians know without any doubt the role of everyone.</p> |
| Lack of training              | <p>Training is a key factor in order to buy all the parts effectively and efficiently. If there is detected a lack of expertise, mistakes can be made, and affected the whole production process</p>     |

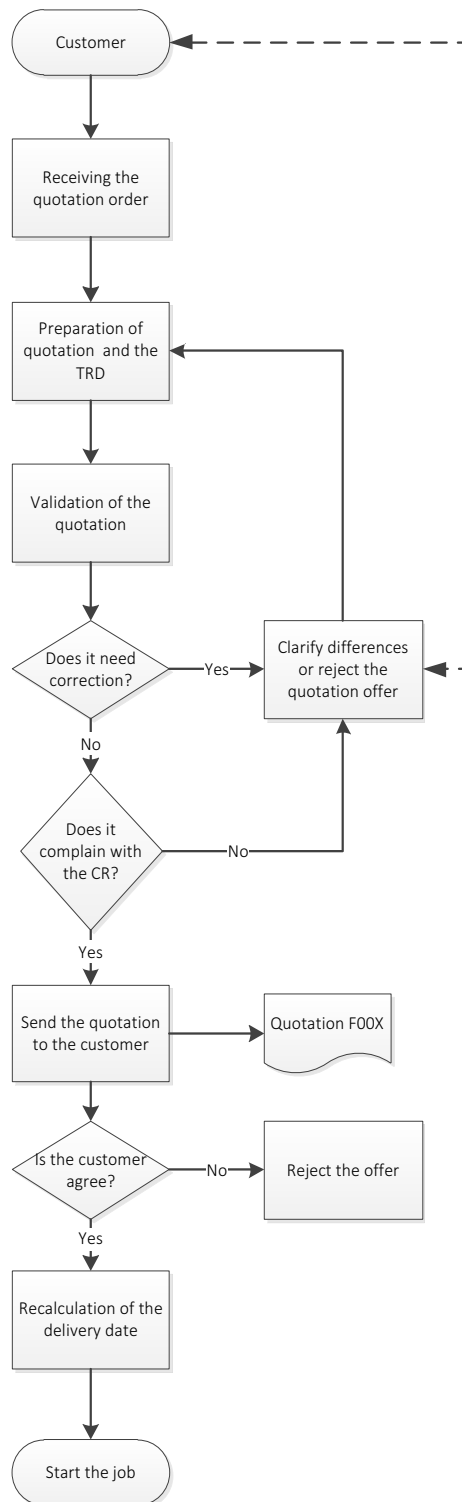
### **5.2.2 Quotation and order management**

The aim of this procedure is to describe all the necessary steps to prepare the quotation and order management in an effective and unequivocal way. Figure 5-2 shows the flowchart for this procedure.

This general quotation and order management procedure will be applied to all quotations. It starts with a commercial dealing and finishes with a quotation offer. Finally, it can be accepted or rejected.

Description of responsibilities for technical roles in each general procedure will be defined in 5.2.1.

- Technology Manager
- Quotation Agent
- System Operator
- Material Consultant
- Process Engineer
- Design Engineer



**Figure 5-2** Quotation and order management flowchart.

Description of each main activity presented in the flowchart follow.

### **A. Receiving the quotation order**

An adequate quotation must contain at least the following information:

- 3D data file.
- Customer requirements:
  - Intended use.
  - Material.
  - Number of parts to build.
  - Required deadline.

## **B. Technical requirement document preparation and cost estimation**

The Quotation Agent is responsible for preparing the simplified Technical Requirement Document (TRD). With the TRD information, both the Quotation Agent and the System Operator will perform the following tasks:

- Determine whether the part will be made with SLM or EBM, and which post processing operations will be carried out in order to meet the initial requirements.
- Calculate the estimated time and volume of the parts.
- Estimate the cost of the complete process.

## **C. Preparation of the quotation**

Once the cost has been estimated, the Quotation Agent will prepare the quotation. In this document, relevant parameters from the simplified TRD will appear.

The delivery date will be also estimated. This depends on the workload of the machine at this time. This quotation offer will have a codification to ensure traceability.

The order for components should include at least the following information:

- Standard references.
- Description of the part.
- Number of parts.
- SI or SAE units.
- STL file of the component.
- Dimensions and tolerances.
- Final mechanical properties.

- Raw material.
- Methods for chemical analysis.
- Sampling methods.
- Post-processing sequence of operations.
- Thermal processing.
- Allowable porosity.
- Packaging.
- Certification process.
- Component labelling.
- Supplementary requirements.

#### **D. Validation of the quotation**

The quotation will be revised by the Technology Manager. If something remains unclear, both the Technology Manager and the Quotation Agent will meet in order to clarify all doubts.

If everything is correct, the Technology Manager will validate the quotation offer.

#### **E. Sending the quotation**

The quotation will be sent by e-mail or other communication methods by the Quotation Agent to the client. If the customer accepts the quotation offer, its status will change from “pending” to “work in progress”. Otherwise, the quotation status will change from “pending” to “rejected offer”.

#### **F. Recalculation of the delivery dates**

Once the quotation is accepted by the customer, before starting the manufacturing process, the System Operator must check the following factors in order to correctly plan the building process:

- Availability of the TRD.
- Availability of machine, raw materials, and consumables.
- Priority of the quotation approved (strategic importance of the customer)

- Identification of the quotation approved. It must be taken in account that each building platform may have parts from different clients. The System Operator must organise the manufacturing process in order to optimise it.

The new schedule will be sent to the Quotation Agent, who will communicate this information to the customer. All the communications will have written support.

This procedure entails many potential quality risks that have to be identified in order to set the performance indicators (see Table 5-5).

**Table 5-3** Potential quality risks associated with procedure 5.2.2.

| <b>Risks</b>                  | <b>Impact</b>  |
|-------------------------------|--|
| Incomplete TRD                | It is important to have all the information in order to offer the service the client needs. Without a complete TRD, the quotation will not cover all the needs of the customer due to the lack of key information. This can lead to manufacturing a useless part. The result will not only be the loss of time and money, but customer satisfaction will also be affected. |
| Work with an obsolete 3D file | A lot of changes to the 3D file can be made during this process. Action must be taken in order to ensure that the latest version of all the parts are in the same folder. Otherwise, an obsolete part might be built. See procedure 5.2.3.   |

### 5.2.3 Identification and traceability of the product

The aim of this procedure is to identify each part throughout all the process, from the STL file to the final product. This general procedure will be applied to all the operations that affect the traceability of the product during the entire manufacturing process.

Following Section 7.5.3 of ISO 9001:2008 [111] and EN 9100:2008 [113], there are two distinct control requirements: product identification and product status. In certain industries such as the aerospace industry, unique product identification is mandatory for safety, regulatory [96; 99; 115], and risk management reasons.

Table 5-4 summarizes the steps that have been developed for this procedure. It also contains relevant considerations.

**Table 5-4** Steps involved in the identification and traceability of the product.

| <b>Steps</b>               | <b>Considerations</b>  |
|----------------------------|--|
| Name of the parts to build | <ul style="list-style-type: none"> <li>- The name of the STL file will be given by the customer, and is the only individual who can change its name.</li> <li>- In the quotation, the name of the file will be defined unambiguously.</li> <li>- It is very important to have the latest version of the file to build. For this purpose, if modifications are made, the name of the folder will be changed, including the version (e.g:v2,v3,v4, etc.)</li> <li>- If the version of the file changes, the quotation must be changed, indicating also the latest version. This is very important to ensure traceability.</li> </ul> |
| Name of the build file     | <ul style="list-style-type: none"> <li>- It is necessary to identify each build platform to</li> </ul>   |



|  |   |
|--|---|
|  | <p>control the production planning [104].</p> <ul style="list-style-type: none"> <li>- It must be taken into account that each build platform can contain different parts from different customers.</li> <li>- The build platform must have a code. Each build platform must have a list of the parts included in it (see register GP02RE01, <i>List of build files</i>, Appendix C, point C.1.1)</li> </ul>  |
| <p>Identification of the parts after the build</p>                 | <ul style="list-style-type: none"> <li>- There are various possibilities for this purpose: <ul style="list-style-type: none"> <li>▪ <i>Parts with different sizes</i>. They are easy to distinguish by simple measurement. In this case the difference can be established with a calliper.</li> <li>▪ <i>Parametric parts</i>. In this case, identification marks must be applied on the piece to identify it.</li> <li>▪ <i>Parts completely different</i>. In this case, it will not be necessary to mark each part.</li> </ul> </li> </ul> |
| <p>Traceability until the part is received by the final client</p> | <ul style="list-style-type: none"> <li>- Each part must be inside a box which identifies it unequivocally.</li> <li>- The information in each box must coincide with the information described in the quotation. Preferably, it should be made with a sticker on the box.</li> <li>- Each part is sent to the client in the same box. Once the client confirms its receipt the job is closed.</li> </ul>  |

This procedure entails many potential quality risks that have to be identified in order to set the performance indicators (see Table 5-5).

**Table 5-5** Potential quality risks associated with procedure 5.2.3.

| <b>Risks</b>   | <b>Impact</b>  |
|--|--|
| Discrepancy between the number of the version in the quotation and the version of the part built | If a file version different from the latest version appears in the quotation, traceability can be lost. In case of future problems, it could not be certain which version was built. |
| Not building the latest version of the part  | An obsolete part can be manufactured if rules of naming are not properly followed.   |
| Not identifying properly the building plate  | The traceability of the part will be completely lost.  |
| Do not identify parts after the build process  | If parts are not put in a box to identify them, a serious traceability problem could occur, especially if parts are geometrically and dimensionally similar.                         |

Table 5-6 shows the suggested performance indicators for this procedure. This parameter gives a representative measure of the effectiveness of the process itself. It is also important to establish a reference value because it is the only way to know if the procedure was carried out correctly or not.

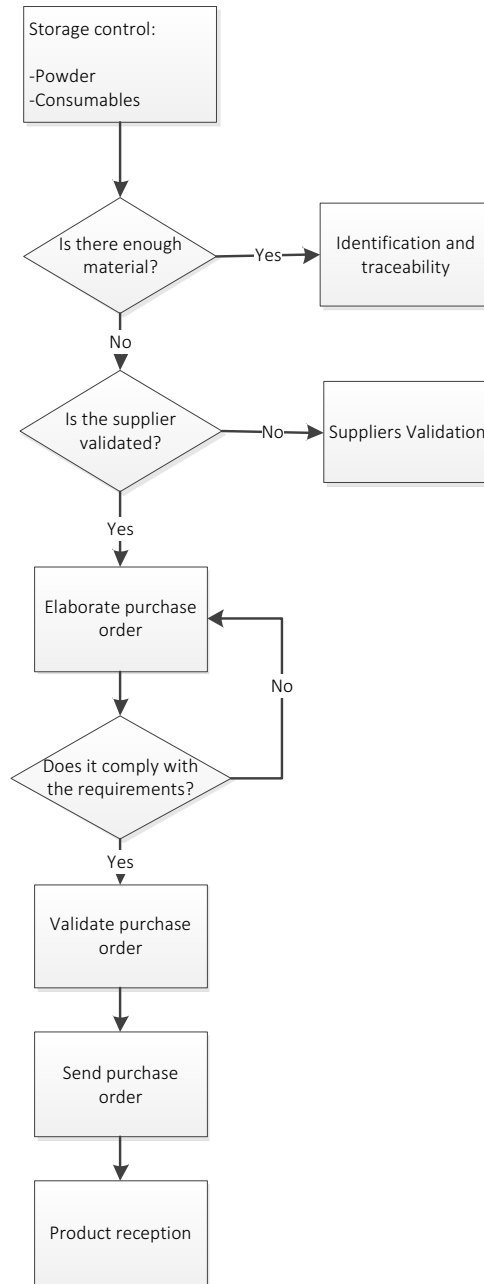
**Table 5-6** Performance indicator for the 5.2.3 procedure.

| <b>Performance Indicator</b>                            | <b>Formula</b>   | <b>Interpretation</b>  |
|---|--|--|
| Degree of effectiveness in identifying non conformities | $\frac{\text{Number of non – conformities due to an identification problem}}{\text{Total number of produced product}}$ | It provides an indicator of the efficiency of the activities involved in this procedure. |

#### **5.2.4 Purchase management**

The aim of this procedure is to define all the necessary steps to prepare the purchase orders of all materials processed by the machine and all the consumables. This procedure will be applied to all the purchase orders relative to the EBM/SLM machine. It also applies to all the subcontracts regarding design, manufacturing or laboratory tests.

Figure 5-3 shows a flow chart of all the activities involved in this procedure.



**Figure 5-3** Purchase management procedure flow chart.

### **A. Storage Control**

The first process, control of raw material and consumables, involves:

#### **Powder**

- The amount of powder stored and inside the machine must be controlled periodically.

- Powder specification must be controlled (chemical composition, particle shape and distribution amongst others)
- There must be a minimum acceptable level of stock established.

### **Consumables**

- The state of the building platform must be supervised periodically. A minimum level of thickness and flatness should be established for each plate and a number of plates must be available for uninterrupted manufacturing.
- Different components of the machine are supervised by the machine's software, and must be revised in accordance with the scheduled maintenance of the machine (100, 200, and 400 hours).

The main elements to be revised before each build on the SLM system are:

- Gas recirculation particle filter: This filter removes all metal particles that have been rejected from the melt pool. Normally, this filter is changed every 36 hours per machine operation.<sup>28</sup>
- Silicone wiper: This wiper evenly spreads the powder across the build chamber (changed every build).<sup>29</sup>
- Argon gas. A supply of argon gas is necessary for SLM system operation. It is recommended to have a large argon tank to supply the system.
- Protective lens. It prevents any particulate matter from contaminating the optical system.
- F- $\theta$  lens<sup>30</sup>. It has to be changed when major irregularities are detected.

The main elements to be revised before each build on the EBM system are:

---

<sup>28</sup> Information gathered from SLM 280HL maintenance document.

<sup>29</sup> Information gathered from SLM 280HL maintenance document.

<sup>30</sup> F- $\theta$  lenses are designed to focus the point laser on a point as well as provide a regular heat shape on the building platform. If irregularities are presented at the lenses, the power of the beam will not be properly focused on the desired point.

- Filaments: These are the active elements for creation of an electron beam (their lifetime is normally approximately 120h, and commonly changed after 100 h)
- Heat shield plates. These are elements which provide heat insulation and maintain working temperature in the build chamber (they are normally changed after 2-3 builds)
- Column foil. It has to be changed when major irregularities are detected.
- Camera film. It prevents camera metallization<sup>31</sup>. Commonly, it is changed after 10 or 15 builds.

For each one of these elements, a minimum stock level should be established.

## **B. Elaboration of the purchase order**

The second process, elaboration of the purchase order, will involve the following activities:

- The System Operator (see Section 5.2.1) must fulfil a purchase order of the powder when the minimum level of powder is reached.
- The System Operator must fulfil a purchase order of any component whose stock has reached a critical level.
- In the case of multiple suppliers, before preparing the purchase order, the System Operator should check the price of the item and delivery on time.
- The purchase order must be made only to previously approved suppliers.
- The purchase order must contain at least the following information:
  - Powder type
  - Size distribution
  - Shape
  - Tap density

---

<sup>31</sup> During the melting process, some of the metal powder will be converted to gas. Camera metallization phenomenon occurs when metal gas solidifies on the camera lenses.[116]

- Flow rate

**C. Validation of the purchase order**

Once the purchase order is complete, the next process is to validate it. For this purpose, the following main actions must be carried out:

- The purchase order will be revised and validated by the Technology Manager.
- In case of any disagreement or if anything needs to be clarified, the Technology Manager will discuss it with the System Operator.
- Once all the aspects of the purchase order are clarified, it will be validated.

**D. Sending the purchase order**

- The purchase order will be sent to the supplier.
- The System Operator will register any incident related to the purchase management.
- The fresh powder reception procedure is defined in Section 5.2.5.
- The reception and storage of other consumables will be set according to the company’s storage procedures.

The potential quality risks that have been identified in this procedure are summarized in Table 5-7.

**Table 5-7** Potential quality risks associated with procedure 5.2.4.

| <b>Risks</b>   | <b>Impact</b>  |
|--|--|
| Deficient control of the quantity of powder and consumables. | <p>If the amount of powder is not controlled, a shortage of stock could occur, making it impossible to start to build.</p> <p>The machine has to be maintained properly. Deficient maintenance could lead to nonconformities in the final product.</p> |

|  |  |
|--|--|
| Problems related to material and consumables suppliers | All materials suppliers must be validated to guarantee the quality (see procedure 5.2.10). |
|--|--|

Table 5-8 suggests the following performance indicator for this procedure.

**Table 5-9** Performance indicator for procedure 5.2.4.

| Performance Indicator | Formula   | Interpretation   |
|-----------------------|---|--|
| Stock out             | Number of process interruptions due to the lack of material (powder or consumables) | It provides an indicator of the problems related to purchase management. |

### 5.2.5 Identification and traceability of raw materials

The aim of this procedure is to ensure the identification and traceability of raw materials during the entire process. This general procedure will be applied to all the operations that are affected by the traceability of raw materials.

Two main operations can be identified in the procedure.

#### A. Fresh powder reception

- The delivery note from the supplier must include the following information:
  - Customer purchase order reference.
  - Quantity of powder (kg).
  - Batch number.
  - Description of the powder (alloy) with the corresponding chemical analysis.
- Fresh powder must always remain in the original receptacle in order to maintain the traceability, until it is used for the first time.



- Fresh powder must be stored in a location habilitated for this purpose. This location will be labelled indicating “Fresh Powder”. No special atmospheric conditions are necessary as long as the powder is contained in the original package.
- The moment the fresh powder is received, it must be checked by the System Operator to make sure that all the aspects are correct (quantity of powder, chemical analysis, purchase order reference, nontoxicity certificate). The checklist must be signed by the person responsible, who can be the System Operator or the Material Consultant. All will be written down in the register note *GP4RE01. Checklist of fresh powder reception* (see Appendix C, point C.1.2).

## **B. Powder management**

There are two possible routes to consider in the use of powder: only fresh powder, or recycled and refreshed powder.

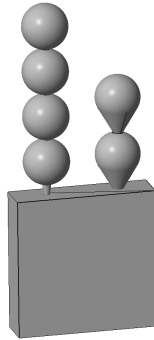
If the chemical composition of the powder does not change during the process, it will not be necessary to take into account the oxygen composition of the manufactured part. Nevertheless, some materials, like Ti6Al4V are affected by oxygen pickup during the manufacturing process (see Section 2.4.1). For this reason, it is compulsory to control the oxygen concentration during the process.

The oxygen concentration in the final part must be controlled. To control the oxygen concentration, different build testers will be produced.

For Ti6Al4V, there is an upper limit in this value established in standard ASTM F2924-14 “Standard Specification for Additive Manufacturing Titanium-6-Aluminium-4 Vanadium with Powder Bed Fusion” [101] for the aerospace sector.

In order to avoid destructive tests, one possibility is to build three different small samples in the building plate. Samples will have a shape formed by three spheres, because from the point of view of oxygen pickup

phenomenon, it is the worst-case scenario<sup>32</sup>. Also, in order to be easily separated to test after the build, “close” sphere shape samples will be produced and proposed as an alternative to the first one (see Figure 5-4).



**Figure 5-4** Shape of the tester.

The other two testers will be kept conveniently identified, with the aim of having a small part with the same composition as the real parts.

### **Fresh powder only**<sup>33</sup>

The final customer could request only fresh/virgin powder despite this not being the most common way. In this case, powder will not be recycled or reused, and the batch will be used until there is enough powder to be able to build the part. It is not critical to test the final part, providing the initial composition of the powder has not been affected.

### **Recycled and refreshed powder**<sup>34</sup>

In this case the powder will initially be used from a single batch and after each build the powder will be stored in the same deposit marking the number of recycling operations the powder has gone through. Each batch will be used until the level of recyclability is exceeded or until there is not enough powder to build the part/s. Then, the recycled powder will be

---

<sup>32</sup> Different geometries were simulated in order to characterize the cooling time of the part, because it determines the severity of the pick up oxygen process. Longer cooling periods will result in a higher content of oxygen.

<sup>33</sup> The powder batch number must be in concordance with the original batch number obtained from the supplier due the traceability of the raw material.

<sup>34</sup> The powder must be unequivocally related to the original batch number

refreshed by mixing it with fresh powder, following refreshing powder operational instructions, Section 5.3.11.

As has been indicated before, it is crucial to control oxygen concentration. The general strategy is to perform chemical analysis of testers after each build and validate its further use. Every build must have an associated test of oxygen concentration.

- Powder refreshment enables the usage of powder beyond the theoretical limit of recyclability; every build will require chemical analysis of the witness after each build. See Operational Instruction relative to powder refreshment.
- All chemical analysis results will be stored in the *CP4ARE01. Recycled Powder Chemical Analysis* (see Appendix C, section C.3.3).

The potential quality risks that have been identified in this procedure are summarized in Table 5-10

**Table 5-10** Potential quality risks associated with procedure 5.2.5.

| Risks   | Impact  |
|---|---|
| Deficient storage of recycled powder.               | If recycled powder is not stored properly, and batches are mixed, all traceability can be lost.   |
| Deficient use of fresh powder. Loss of traceability | The chosen strategy must be followed carefully (batch-by-batch usage or powder refreshing). It must always be possible to identify the powder origin. |

### 5.2.6 Control of measuring equipment

The aim of this procedure is to guarantee the control and maintenance of the measuring equipment. This general procedure applies to all the measuring equipment used by the company to ensure the conformity of the final products.

The main activities identified for this procedure are as follow:

### **A. Codification and inventory**

- All the measuring equipment used in the process must be codified. They should be assigned with an alphanumeric code.
- The codification of every equipment must be registered in the register *GP5RE01 “Measuring equipment list”* (see Appendix C, section C.1.3)
- All measuring equipment must be identified, indicating its calibration condition and/or any use restriction.

### **B. Measuring equipment control and test**

- If calibration is external, it will be made by an approved laboratory. After receiving the external calibration, it must be verified if all the measuring equipment has been returned in the same condition as when it was sent, as well as that all the calibration certificates and calibration labels are correct.
- If calibration is internal, all the calibration procedures must be clearly defined, using adequate patterns and procedures.

### **C. Register and assessment of calibration**

All the results from the control of the measuring equipment, and the assessment (“OK”, “Not OK”, “Out of order”) will be registered in a document called “Calibration Plan”. The System Operator will decide if the measuring equipment is fit for its purpose.

### **D. Calibration periodicity**

- The main factors to determine the periodicity between measuring equipment calibration are:
  - Type of equipment and use frequency.
  - Manufacturer indications.
  - Maintenance and use history.
  - Accuracy needs.
  - Environmental conditions.
- If it is necessary, between calibrations, the System Operator can check the correct use of the equipment, to guarantee the results in the measurements coincide with the deviations and uncertainty obtained in

the last calibration. If deviations are detected, corrective actions will be taken, repairing or replacing the measuring equipment until the next calibration.

The potential quality risks that have been identified in this procedure are summarized in Table 5-11.

**Table 5-11** Potential quality risks associated with procedure 5.2.6.

| <b>Risks</b>                                | <b>Impact</b>  |
|---|--|
| Loss of accuracy of the measuring equipment | Many manufacturing parts out of tolerance could be accepted instead of being rejected. |

### **5.2.7 Complaint management**

The aim of this procedure is to establish a methodology to identify and manage complaints received from the final customer, and to evaluate customer satisfaction.

This procedure will apply to all complaints made by the customers regarding the manufacturing of products by EBM/SLM.

The main activities identified for this procedure are as follow:

#### **A. Collection and management of complaints and claims**

- Complaints, claims and suggestions received by the company can be received by e-mail, fax or phone.
- In the case of verbal complaint, it is necessary to formalize it in order to make a formal analysis of the customer satisfaction.
- Once managed and solved, the complaints will be registered in *GP7RE01. Complaints and suggestions list* (see Appendix C, section C.1.7). The solution proposed must be given.
- After analysing each complaint, the Technology Manager will decide if it is appropriate to open a non-conformity report, *GP8RE01. Report of non-*

*conformity, corrective action and preventive action* (see Appendix C, section C.1.8) as established in procedure 5.2.8.

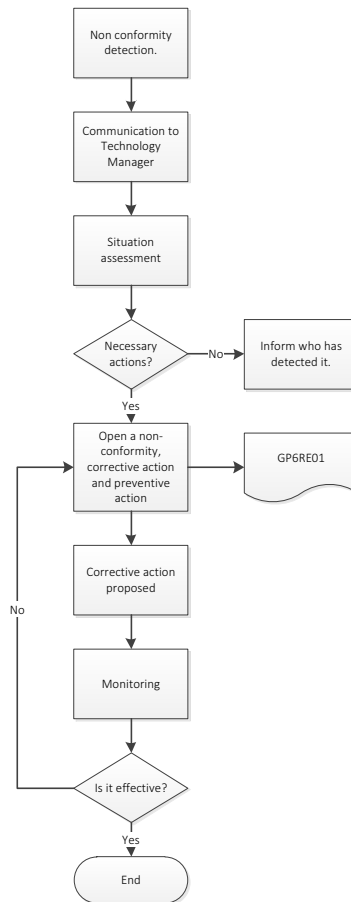
#### **B. Complaint and suggestion assessment**

- Periodically, a report of complaints and suggestions must be prepared. This is very important in order to study and obtain an impression of the degree of customer satisfaction.

#### **5.2.8 Non-conformities, corrective, and preventive actions**

The aim of this procedure is to establish a methodology to identify and manage non-conformities, corrective, and preventive actions. This procedure applies to all non-conformities detected during the manufacturing of products by EBM/SLM.

Figure 5-5 shows a flow chart of this procedure.



**Figure 5-5** Non conformities, corrective and preventive actions.

The following activities can be identified in this procedure.

**A. Non-conformity detection**

Every staff member can identify a non-conformity. It will be reported to the Technology Manager, either for a corrective or preventive action, depending on whether it is a real or a potential non conformity.

The Technology Manager will study the non-conformity to decide if it is necessary to open a report of non-conformity, corrective action and preventive action *GP8RE01. Report of non-conformity, corrective action and preventive action* (see Appendix C, section C.1.8). If it is not necessary to open such a report, the staff member who has identified the non-conformity will receive a brief explanation.

**B. Non-compliant product**

When a non-compliant product is detected, the non-conformity will be studied and a corresponding non-conformity report will be opened. Thereupon, the product will be marked with a yellow label. Two options are available:

- It is possible to make the product fulfil the specified requirements after being reprocessed. The reprocessing is selected and approved by the Technology Manager and notified to the involved staff so as to start the work.
- If the product cannot be reprocessed, it will be marked with a red label. The decision and destination of the material will be indicated in the non-conformity report.

Regarding the control of fresh and recycled/refreshed powder, general procedures regarding to the purchase of fresh material (see procedure 5.2.4) and the identification and traceability of material (see procedure 5.2.5) will be followed.

### **C. Investigation of causes**

An investigation of the non-conformities, real or potential, will be opened to determine the causes. The cause/(s) will be recorded in *GP8RE01 Report of non-conformity, corrective action and preventive action* (see Appendix C, section C.1.8).

The Technology Manager will decide if it is necessary to implement actions after investigating the non-conformity. It will depend on the gravity and the probability of reoccurrence.

### **D. Monitoring and closure**

Continuous monitoring shall be made of all scheduled actions, in order to ensure that the action has been correctly implemented in the system. The monitoring will be registered in the report of non-conformity, corrective action and preventive action *GP8RE01 Report of non-conformity, corrective action and preventive action* (see Appendix C, section C.1.8).



After checking the effectiveness of the actions implemented, the Technology Manager will close the corrective and preventive actions, registered in *GP8RE01 Report of non-conformity, corrective action and preventive action* (see Appendix C, section C.1.8).

The potential quality risks identified in this procedure are summarized in Table 5-12.

**Table 5-12** Potential quality risks associated with procedure 5.2.8.

| <b>Risks</b>                           | <b>Impact</b>  |
|--|--|
| Lack of involvement of the technicians | If technicians are not really involved in the quality system, they could not report the non-conformities or the opportunities for improvements. It is really important to have all the technicians motivated and ready to detect aspects that could be improved. |
| Not registering non-conformities       | If there is no written record, a lot of useful information can be lost, and it will be almost impossible to analyse the causes of the non-conformities.  |

Table 5-13 shows a suggested performance indicator for evaluating the efficiency of this procedure.

**Table 5-13** Performance indicators for procedure 5.2.8.

| <b>Performance Indicator</b>  | <b>Formula</b>  | <b>Interpretation</b>                                |
|-------------------------------|---|--|
| Non-conformities investigated | $\frac{\text{Number of non conformities investigated}}{\text{Number of non conformities detected}}$ | Indicates the company's concern about quality issues |

### 5.2.9 Document management

The aim of this procedure is to establish general guidelines for documentation control: development, approval, identification and changes, review and updating, distribution and control, to ensure that there are no obsolete documents. All the documents must be accessible and identifiable in at every moment.

This general procedure is applicable to all the documents involved in the quality system which are presented as follows:

- General procedures.
- Operational instructions.
- Registers.
- External documents.
- Applicable legislation.

The quality system must contain at least the following documents:

**Table 5-14** Fundamental documents of the quality system.

| <b>Document</b> | <b>Description</b>   |
|-----------------|--|
| Quality Manual  | Base document of the quality system. It makes reference to the system scope, the developed procedures and a description of the system processes. |

|                          |  |
|--------------------------|--|
| General Procedures       | Documents that specify the behaviour of the professionals involved with EBM/SLM.   |
| Operational Instructions | Documents which describe in greater detail all the operational aspects related to EBM/SLM.                                     |
| Forms and Registers      | Forms are the templates used to record useful information on the system. Once filled, they become part of the system register. |
| Other documents          | Standards and applicable legislation, instruction manuals, etc.  |

Documents must be codified in order to identify them without mistakes. In this MSc by Research thesis the criteria that have been selected are described as:

- **General Procedures.** Codified as GPXX, where:
  - GP stands for “General Procedure”
  - XX are two digits concerning the procedure order starting at 01
- **Operational Instructions.** Codified as OIXX, where:
  - OI stands for “Operational Instructions”
  - XX are two digits concerning the operational instruction order starting at 01
- **Control Procedures.** Codified as CPXX, where:
  - CP stands for “Control Procedure”
  - XX are two digits concerning the control procedure starting at 01

- **Forms and registers.** Codified as GPXXREYY, OIXXREYY or CPXXREYY depending of the procedure they are associated with.
  - RE indicates that is a register of the system.
  - YY are two digits concerning the register order starting in number 01.

All the documents regarding the quality system must be controlled. Hence this document must contain a written procedure, which defines the necessary controls to:

- Approve the documents
- Revise and update the documents, and re-approve when necessary.
- Make sure that all the changes are identified, and added to the current version.
- Make sure that the documents remain legible and easily identifiable
- Make sure that all the external documents necessary for the planning and operation of the quality system, are identified and controlled
- Avoid the unintended use of obsolete documents, and identify them.

The potential quality risks identified in this procedure are summarized in Table 5-15

**Table 5-15** Potential quality risks associated with procedure 5.2.9.

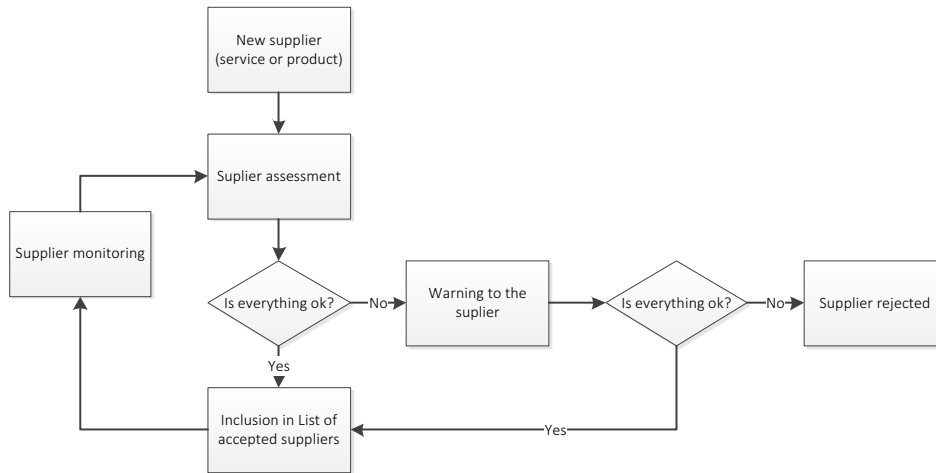
| <b>Risks</b>                            | <b>Impact</b>                          |
|---|--|
| Building a non-practical quality system | Confusion between different documents. |

### **5.2.10 Suppliers validation**

The aim of this procedure is to define a methodology to evaluate and validate any kind of suppliers (materials suppliers, design suppliers, fabrication suppliers, and test laboratories), with the aim to select suppliers capable of fulfilling all the given criteria.

This procedure is applicable to all suppliers, existent or new (material suppliers, design suppliers, fabrication suppliers, and test laboratories).

Figure 5-6 shows a flow chart of this general procedure.



**Figure 5-6** Supplier validation flowchart.

The following activities can be identified:

### **A. New supplier's assessment**

Every new supplier who wishes to be included in the list of certificated suppliers will receive a formulary *GP10RE01. Questionnaire previous to initial validation of suppliers* (see Appendix C, section C.1.9). This document is compulsory in order to start a relationship with a new supplier. This step will be performed by the person with responsibility for sales.

Later, with enough criteria, an initial assessment of the supplier will be carried out by completing register *GP10RE02. Supplier assessment* (see Appendix C, section C.1.10). The assessment will be the responsibility of the Technology Manager.

General criteria to assess suppliers:

- Certified by ISO 9000 (general purpose), ISO 9100 (aviation suppliers).
- Product/service quality.
- Identification and traceability of their products/services.

- Signed agreement before registration.
- Resources and logistic capability.
- Compliance with delivery time( average response, punctuality and good practice).

If necessary, additional meetings could be arranged with suppliers in order to visit the supplier's installations and compile information.

Depending on the sector, more criteria could be added by the Technology Manager. Each criterion will have a value. All criteria will be added up in order to classify suppliers into one of the three following categories:

**Table 5-16** Suppliers qualification.

| <b>Category</b> | <b>Type of Supplier</b> |
|-----------------|-------------------------|
| A               | Preferred Supplier      |
| B               | Satisfactory            |
| C               | Unsatisfactory          |

If a supplier has been considered suitable, the Technology Manager/ Quotation Agent will incorporate it in the company register in *GP10RE03*.  
*List of accepted suppliers* (see Appendix C, section C.1.11)

The Technology Manager/ Quotation Agent will communicate in written form to the supplier the results of the assessment, and the possible consequences of being in category B or C:

- If it is category B: an improvement plan will be demanded.
- If it is category C: an improvement plan will be demanded, and the supplier will be warned of the consequences if the plan is not established, which can lead to removal from the list of accepted suppliers.

The Technology Manager can decide to reassess existing suppliers when necessary, according to the points mentioned above.

## B. Continued assessment-supplier surveillance

A register of incidents of each supplier will exist, *GP10RE04. Register of supplier incidents* (see Appendix C, section C.1.12) specifying if they imply any non-conformity. If it is the case, a non-conformity report will be opened according to procedure 5.2.8.

Moreover, to reassess suppliers, the positive contributions that the supplier has made during the year to the Quality Assurance System (new materials, tendency reports, quick response to consultations, etc.) will be taken into account.

Reassessment of suppliers will be made at least once a year. All the new information will be recorded in the register *GP10RE05. Continued Assessment of suppliers* (see Appendix C, section C.1.13). Each supplier will be classified in categories, as described previously, based on the results of this assessment.

Table 5-17 shows a suggested performance indicator to evaluate the efficiency of the procedure.

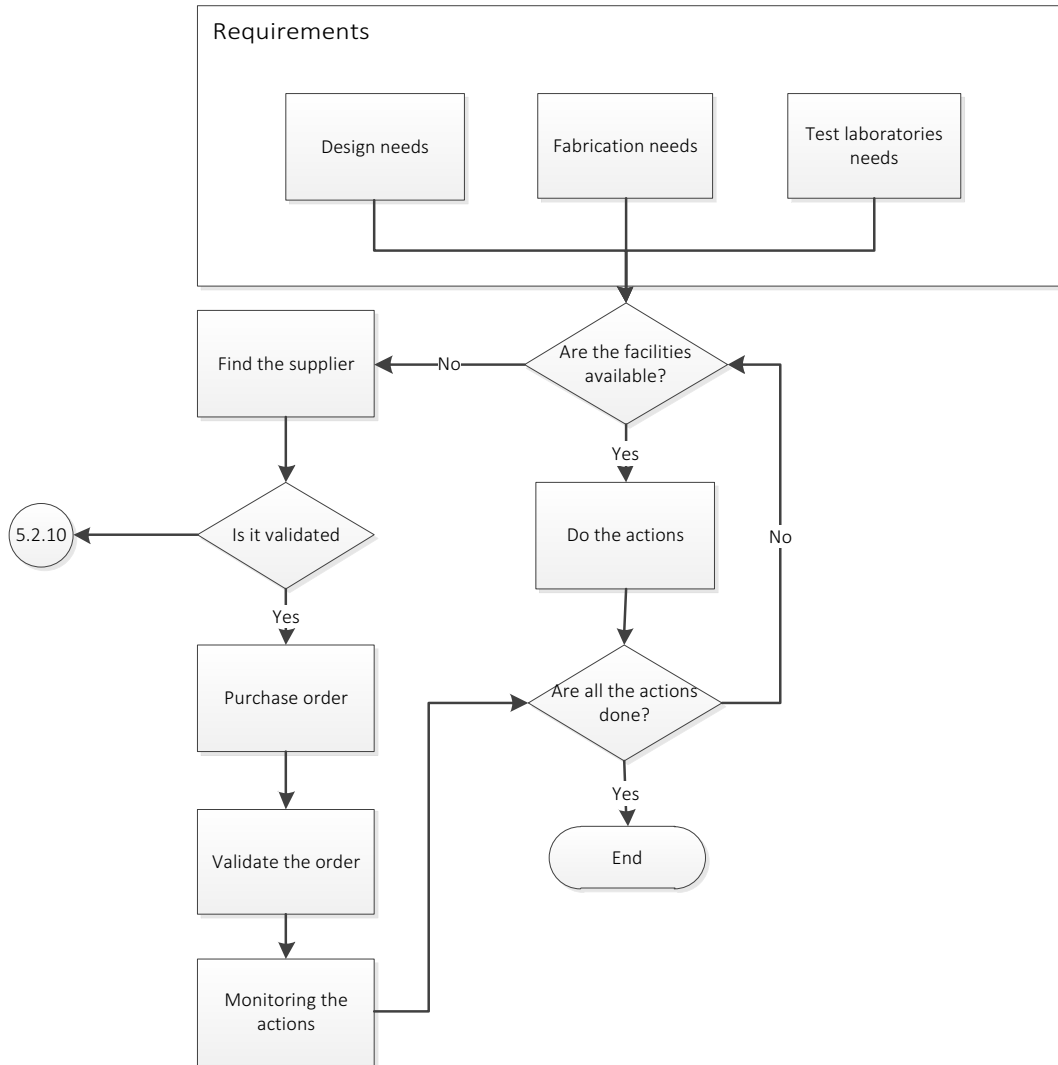
**Table 5-17** Performance indicator for procedure 5.2.10.

| <b>Performance Indicator</b>      | <b>Formula</b>   | <b>Interpretation</b>                  |
|-----------------------------------|--|--|
| Percentage of validated suppliers | $\frac{\text{Number of validated suppliers}}{\text{Number of supplier evaluated}}$ | Indicates the quality of the suppliers |

### 5.2.11 Subcontracting management

The aim of this procedure is to describe a procedure involving all the necessary steps to manage the services subcontracted.

This procedure applies to all subcontracts, which affect the additive manufacturing process. Design, manufacturing and laboratory tests are included in this procedure (see Figure 5-7).



**Figure 5-7** Subcontracts management flowchart.

The following main activities can be identified in the procedure.

**A. Requirement capture**

- A particular requirement is identified, related to design, manufacturing or testing, which cannot be carried it out by our own means.

**B. Supplier selection**

- An external company qualified to do this task must be found. This supplier must be validated.



- If the potential supplier has not been validated, the procedure described in 5.2.10 must be followed.

### **C. Purchase order**

- The purchase order must include the deadline required
- Depending on the provider type, purchase orders must identify unequivocally the technical requirements.
- Purchase orders for a design supplier must include:
  - Description or part number of product desired.
  - 3D file.
  - Dimensions and tolerances.
  - Mechanical properties.
  - Supplementary requirements.
- Purchase orders for manufacturing suppliers must include at least the same aspects included in the quotation order established in procedure 5.2.2.
  - Description or part number of product desired.
  - 3D file.
  - Quantity.
  - Final dimensions and tolerances.
  - Mechanical properties.
  - Supplementary requirements, if necessary.
  - Post-processing sequence of operations.
  - Thermal processing.
  - Allowable porosity.
  - Supplementary requirements.
- Purchase orders for testing suppliers must include:
  - Description or part number of product to test.
  - Quantity of product to test.
  - Mechanical properties.
  - Methods for chemical analysis.
  - Sampling methods.
  - Supplementary requirements.

#### **D. Order Validation**

- The quotation received from the supplier will be revised by the Technology Manager.
- At validation, all the technical matters and the deadline must be clear in the quotation. All verbal agreements will be later written in order to avoid misunderstandings between the two parties.
- If everything is correct, the Technology Manager will validate the quotation.

#### **E. Action monitoring**

- Compared to a raw material purchase order, subcontracts must be monitored to check if the deadline is going to be affected and help offered in case of problems or if clarifications are needed
- If any incident has occurred, the incident will be recorded in *GP10RE0. Register of supplier incidents* (see Appendix C, section C.1.12), specifying if they involve any non-conformity. If it does, a non-conformity report will be opened according to the procedure described in 5.2.8.

### **5.3 Operational instructions for EBM/SLM based supply chain**

This section defines all operational instructions necessary for Quality Assurance during the process of AM of aerospace parts. The procedures have been formulated in compliance with the general guidelines of ISO 9001 [113].

To carry out this section, many discussions and opinions from experts in the area of AM have been taken into account. It is very important to mention in particular the contributions of two partners of the RepAIR project, AIMME and the Danish TEKNOLOGISK INSTITUT.

The purpose of this section is to develop a general framework to standardise operating procedures. It is important to emphasise that these operational instructions do not replace the instruction manual of the machine, which may change from one model to another. Health and Safety aspects are also included in the Instruction Manual.

### **5.3.1 General build preparation**

To prepare the building process for an EBM or SLM machine, the following operational instructions have been defined:

#### **A. Loading of STL File(s) to the computer**

In order to properly load file(s) into the proper software, the following steps should be followed

- Select the machine scene which will be used for the AM system.
- Create a start plate of the standard dimensions of the same size that will be used in step 5.3.2 or 5.3.3, and position its upper surface at zero level.
- Load the part model(s) into the build area and position them over the start plate.

#### **B. Verification of STL File(s)**

The loaded part(s) should be verified for any geometrical irregularities by:

- Checking whether the file has all STL facets well connected and has no irregularities.
- Pass the fixing function into the proper software over STL, in case some irregular items are detected.

#### **C. Part orientation for the manufacture**

According to the build analysis, the following steps should be performed:

- Position the part model manually in the vertical direction (normally z-axis) for optimal production from the economic and delivery time standpoint, using the 'Move' and 'Rotate' function.
- Ensure that there are no overlaps between different parts and that the parts are not too close to each other, which could lead to build problems.

#### **D. Create support structure**

For optimal heat conduction and support of down facing surfaces, a proper support structure should be generated by:

- Creating the structure that connects the down facing surfaces of the model to the start plate, using 'Support Generation' module.

- Ensure efficient removal of residual heat from the selective melting process by selecting an appropriate section of the support structure.
- Follow Design & Planning Guide for fabrications.

#### **E. Export for the oriented STL file**

Once fixed into the position, oriented and provided with an adequate support structure, each part should be exported into an 'oriented STL' file.

For EBM:

- Solid parts should be saved under a name containing "melt", lattice structures under a name containing "net" and support structures under a name containing "wafer", so as to distinguish the models properly and to be able to assign an adequate set of parameters for each one.

In some cases, it can be useful to perform Boolean operations over all solids, all net, and all wafers, to minimize the number of build models. However, it can be a shortcoming later if, due to a problem in a particular build zone, some of the parts should be turned off.

- Record the overall build height, since it will represent a control measure when the parts are loaded into a build file.

For SLM:

- Part files will be exported in STL file format. The support structures automatically get an "s\_in" from of the part file name to distinguish files. These allow separate processing parameters to be allocated for the build.

### **5.3.2 Build preparation for EBM**

To prepare the manufacturing process for the EBM machine, the following operational instructions have been defined:

#### **A. Selection of the start plate**

- Select the start plate according to the dimensions established in step 5.3.1.

#### **B. Importing models**

- Create models for each part that is going to be loaded. It is important to name them accordingly.

- Import part models to be manufactured.

### C. Slicing of models

- Select the appropriate layer thickness for the manufacturing process. This value will determine the settings of other build parameters.
- Perform the slicing of the set of imported models.
- Check the appearance of layers in the EBM builder by moving the slider from the first to the last layer and detect if any error appears.
- Check that the first layer corresponds to the value of the layer thickness and that the last one corresponds to the expected build height.

### D. Save the build data to an “.abf” file

- Save the layers of sliced models into a build file
- Save it under a name corresponding to the codification<sup>35</sup> of build files slated in the GP2RE01 register (see Appendix C, section C.1.1).

### E. External conditions

To ensure the correct build, it is necessary to control several external parameters. Table 5-18 summarize this information.

**Table 5-18** External aspect to control during the preparation of the EBM machine.

| External Aspects         | Optimal Values   |
|--------------------------|--|
| Environmental conditions | Temperature of the room must be between 20°C and 23°C, and relative humidity less than 40%   |
| Helium                   | <ul style="list-style-type: none"> <li>○ To reduce the cooling time and maintain the controlled vacuum helium is let into the vacuum</li> <li>○ Every 100 hours the level of helium must be checked. Pressure must be</li> </ul> |

---

<sup>35</sup> Information collected from Arcam [43] and experimental results from AIMME (www.aimme.com)

|                |   |
|----------------|---|
|                | between 0.8 bar and 1 bar.  |
| Power failure  | <ul style="list-style-type: none"> <li>○ System disposes of a UPSS (Uninterrupted Power Supply System) to avoid the stop of the build in the event of failure in the electric supply.</li> </ul> <p>However, UPSS has a limited length. In case of electric supply failure, the system operator will have only 20 minutes to avoid the stop of the build.</p> |
| Compressed air | <ul style="list-style-type: none"> <li>○ Compressed air is used in auxiliary equipment. Pressure must be between 5 bar and 6 bar.</li> </ul>  |

### 5.3.3 Build preparation for SLM

To prepare the manufacturing process for the SLM machine, the following operational instructions have been defined:

#### A. Selection of the start plate

- Select the start plate according to the dimensions established in step 5.3.1.

#### B. Importing models

- Create models for each part that is going to be loaded. It is important to name them accordingly.
- Import part models to be manufactured.

#### C. Slicing of models

- Select the appropriate layer thickness for the manufacturing process. This value will determine the settings of other build parameters.
- Merge the part files and support files and assign the correct material processing parameter file for the build.

- Generate hatch spaces<sup>36</sup>. Those determine all laser scan paths for the build.
- Check the appearance of layers in the SLM builder by examining the entire virtual build from the first to the last layer and detect if any error appears.
- Check that the first layer corresponds to the value of the layer thickness and that the last one corresponds to the expected build height.

**D. Save the build data to a “.rea” file**

- Save the layers of sliced models into a build file
- Save it under a name corresponding to the codification of build files slated in the GP2RE01 register (see Appendix C, section C.1.1).

**E. Save the complete build data to a “.fas” file**

- Insert all the .rea files that are planned for the build. Builds normally consist of multiple files.
- Save it as a .fas file, with a name corresponding to the codification of build files stated in the GP2RE01 register (see Appendix C, section C.1.1).

**F. External conditions**

To ensure the correct build, it is necessary to control several external aspects. Table 5-19 summarizes this information.

**Table 5-19** External aspect to control during the preparation of the SLM machine.<sup>37</sup>

| External aspects         | Optimal values  |
|--------------------------|---|
| Environmental conditions | In order to ensure optimal conditions for the powder, temperature must be between 20°C and 23°C, and relative humidity less than to 10% |

<sup>36</sup> See Appendix E

<sup>37</sup> Information collected from the company SLM solutions (<http://www.stage.slm-solutions.com>) and contrasted with experimental results from the Danish Technological Institute.

|              |   |
|--------------|---|
| Gas pressure | <ul style="list-style-type: none"> <li>○ Used to control oxygen content in the build the argon is purged throughout the build chamber.</li> <li>○ The gas pressure (argon/ nitrogen) in the process chamber should be set to 12 mbar.</li> <li>○ The gas pressure at the machine entrance should be around 6 bar.</li> <li>○ If the gas supply is discontinuous (via bottles) the remaining gas amount should be checked for overnight builds.</li> </ul> |
|--------------|---|

### 5.3.4 Physical preparation of the EBM machine

The following operational instructions have been defined to carry out the physical preparation of the EBM machine,

#### A. Machine preparation: Filling the recycled powder into deposits

- Bring the sieving buckle close to the machine.
- Check if the deposits are closed.
- Fill both deposits equally by using a little shovel.
- Return the deposits to their normal position.

#### B. Machine preparation: Preliminary machine testing – sensors

- Manually check the proper operation of the thermocouple by applying the heat of the gloved hand to the thermocouple plate.
- Check that the film in the video camera moves correctly and is not jammed.

#### C. Machine preparation: Preliminary machine testing – electron gun

- Check the filament usage hours and replace it if necessary. For replacing of the filament, consult the machine's manual.
- Check if the gun column is clean by using the auxiliary mirror. The column should not contain any hanging elements and major irregularities. If so, change the foil with another one. For changing the foil, consult the machine's manual.

#### D. Machine preparation: Levelling of the start plate



The start plate is levelled to be parallel to the rake in order to make proper powder layers. This is done using the 'Machine Setup -Powder Dispatcher' window.

- Position the build platform at approximately 45mm of depth.
- Open the tanks and pour powder from the tanks into the build chamber until approximately 40mm of homogeneous height is reached.
- Take out the thermocouple<sup>38</sup> to the surface with an appropriate tool (e.g. Allen key).
- Outside the machine, take a clean start plate and mark it with an X in the centre; then position it over the powder ensuring it lies in good contact with the thermocouple.
- Lower the start plate by lowering the build platform and make it be lower than the level of the rake blades; fetch the powder from both deposits using the rake left and right position so as to cover the start plate completely.
- When the start plate is levelled, lower it for the heat compensation height, cover it with powder and sweep the powder out using the brush. The start plate must be perfectly clean.

#### **E. Machine preparation: Closing the machine**

In this step, the machine is closed and put under vacuum.

- Check that the inner walls of the heat shield do not have any crisps or metallization hanging. If so, change them.
- Place the heat shield over the rails and press it well.
- Ensure that the deposits are open and no tools left in the interior of the machine.
- Clean the door gasket and the wall where the gasket sits thoroughly.
- Close the door and press "Vacuum" play button. If the vacuum hasn't decreased below 0.8 bar a minute period, stop the vacuum process and open and clean the door again. Repeat the process.

---

<sup>38</sup> A thermocouple is a temperature-measuring sensor.

After closing the door, the machine takes around 20-30 minutes to reach the vacuum necessary for building (approx  $<10^{-4}$ mbar). The software preparation of the machine (Section 5) cannot be finished before this milestone has been achieved.

#### **F. Part evacuation: Open the machine**

- Open the machine. If the machine was under build before, open it only when the chamber temperature is below 100°C.
- Open the lateral sheet slowly in order to avoid the powder falling on the floor.
- Remove the heat shield and close the deposits.

#### **G. Part removal to powder recovery system (PRS)**

The parts and all sintered powder are transferred to the Powder Recovery System (PRS) for sandblasting in this step.

- Release the start plate from the sintered powder below it using an appropriate tool (screwdriver, small trowel) and separate it gently from the thermocouple.
- Hook the transport tray to the powder chamber.
- Move the plate with parts embedded in the sintered powder to the transport tray.
- Separate the sintered powder that was lying underneath the plate from the thermocouple and place it into the transport tray.
- Take the content of the transport tray into the P.R.S.

### **5.3.5 Physical preparation of the SLM machine**

The following operational instructions have been defined to carry out the physical preparation of the SLM machine.

#### **A. System clean down**

In this step, the process chamber is cleaned and any residual material from the previous build removed. If the machine is not dedicated to one material type the whole machine (not only the process chamber) must be cleaned.

- The wiper arm assembly is removed and cleaned
- Silicone wipers are replaced
- Remove any remaining powder and residual particles with ATEX<sup>39</sup> approved vacuum cleaner
- Clean chamber with isopropanol solution
- Protective lens is cleaned with isopropanol solution.
- Re-assemble the wiper assembly.
- Remove the used particle filter and replace with a new one.

### **B. Machine preparation: Powder loading**

This includes the steps needed to load the powder into the system.

- Load the powder into a loading canister
- Lock the canister into the powder port at the rear of the system
- Use the load powder command on the system console to feed the powder through the delivery mechanism until the powder starts to enter the build chamber
- Position the wiper mechanism over the delivery port. Put enough powder that permits to start the manufacturing process.
- Ensure that the powder sensor switch has been engaged, and is showing “OK” on the control software.

### **C. Machine preparation: Levelling of the start plate**

In this step, the start plate is levelled to be parallel to the wiper in order to make proper powder layers.

1. Position the build platform at 0 mm in the vertical axis.
2. Select a prepared machined and levelled substrate and measure the thickness with a micrometre calliper
3. Secure the substrate into the system and secure with bolts to the piston mechanism
4. Lower the piston to the measured height of the substrate.

---

<sup>39</sup> Equipment approved to use in Potentially Explosive Atmosphere.

5. Turn the platform heater on to the correct temperature for the build, check that the platform temperature has reached the designated value using the control software
6. Move the wiper arm across the build chamber and back to its datum position
7. Inspect the coating of powder on the substrate. Ensure that there is an even covering of powder and that the substrate can still be seen through the thin layer of powder. If the powder layer is not correct, adjust the piston height and recoat with powder. Repeat if necessary.

#### **D. Machine preparation: Closing the machine**

In this step, the machine is closed and set ready for the build to start.

1. Close all access points to the build chamber and ensure all seals are gas tight.
2. Supply the build chamber with argon gas using the control software
3. Check that the chamber has reached the desired pressure using the control software and the pressure gauge on the system.
4. Monitor the O<sub>2</sub> content in the chamber until it reaches 0.2%.
5. Turn on the laser using the control software.

#### **E. Part removal: Open the machine**

- Ensure that both the gas supply and laser is turned off.
- Move the wiper arm to the datum position using the control software  
Move the piston to the datum position using the control software
- Open the machine. If the machine was under build before, open it only when the chamber temperature is below 100°C.

#### **F. Part removal and transportation to powder recovery system**

- Move all un-sintered powder into the overflow container at the front of the build chamber using a fine brush.
- Remove the bolts securing the substrate to the piston and remove as much powder as possible from the parts within the build chamber
- Remove the part and the substrate to post processing for part removal and finishing.
- Remove the content of the overflow container to powder recycling

- Pass the collected powder through graded sieves that are suitable for the size range of powder that has been used.
- Dispose of material collected in sieves and recycle powder that has been passed through all sieves.

### **5.3.6 Software preparation for EBM machine**

To carry out the software preparation of the EBM machine, the following operational instructions have been defined:

#### **A. Hardware setup: Start the electrical circuit**

In this step, the process chamber is cleaned down and any residual material from the previous builds is removed. In order to start the build, after having reached the goal value of vacuum, the first step is to start the electric circuit.

- Connect the electric circuit by pressing the "Power Supply" play button and enter the corresponding power window
- Follow the evolution of the beam current and high voltage until they reach the goal values. The target voltage is always 60kV.
- Once the goal values are reached, increase the voltage to 61 kV and 62 kV with a pause of a couple of seconds to test the electron gun. Then return to 60 kV.

#### **B. Build setup**

- Select the correct ".abf" file and load it into the software.
- Record the reference number of the powder batch so as to ensure raw material traceability.
- Ensure that the manufacturing starts from the first layer by checking the "Current Height" in "Build Information" (e.g. if the layer thickness is 50 $\mu$ m the "Current Height" should be 0.05mm). If necessary, reset it up to the first layer.
- Check that the Build Height is the same as in step 5.3.4
- Select the start plate of the proper size (defined in 5.3.2).
- Select the type of material (Ti64, CoCr, etc.)

#### **C. Process setup**

- Define the steps in the “Process setup” following the appropriate sequence: preheating, melting, melting of porous structures (net), melting support structure (wafer).
- Assign all models to the corresponding parameter set (melt to melt, net to net, etc.)

### **5.3.7 Software preparation of the SLM machine**

#### **A. Build setup**

- Select the correct “.fas” file and load it into the software
- Record the reference number of the powder batch so as to ensure raw material traceability.
- Record all laser processing parameters that will be used and all parts that are to be built.
- Ensure all sensors are showing OK, these include:
  - Cabinet Temp
  - Chamber Temp
  - Pump\_1 Temp
  - Scanner Temp
  - Build Platform-actual Temp
  - Build Platform-set Temp
  - Main Tank Powder Sensor
  - Chamber 1-Oxygen
  - Process Chamber Pressure
  - Process Chamber Door
  - Emergency Stop
  - Scanner.

### **5.3.8 Sandblasting the part**

After the build process and when the temperature is low enough to extract the part, the technician picks out the build platform and introduces it into the PRS, for sandblasting. The aim of sandblast is to clean the part and remove sintered powder that is adhered to the part.

In this step, the parts are sandblasted and stored in labelled boxes.

- Close the PRS. door and turn on the light and pressure.
- Wear rubber gloves taking the PRS. pistol in one hand.
- Action the foot pedal and project the jet of air charged with powder particles towards the parts and sintered blocks of powder
- Continue until the parts are completely clean from sintered powder. If necessary, turn off the PRS and take out the parts to check the cleanliness.
- Take the parts to the transport tray and separate them into the corresponding and previously labelled boxes.

### **5.3.9 Support removal after build**

Following the sandblasting of parts, the parts are transferred to the mechanical workshop for support elimination. The support is designed to be easily removed since it has small contact surface with the solid part. Hence, it is sufficient to use hand pliers to separate the support elements from the part one by one.

After the part has been released from its support, it should be placed in the corresponding box and separated from other parts. Following the description in Section 5.2.3, parts in a multipart build are identified and separated one from each the other. Once the parts are separated, each is sent to the corresponding post processing stage.

### **5.3.10 Post-processing procedure**

There are three possibilities depending on the aim of the part:

#### **A. Machining**

The surfaces of the part that require specific roughness or specific surface quality must be machined. Moreover, some part details have critical holes and mating surfaces that must fit together with others, requiring machining at the end of the process.

The Design Engineer sends AM parts together with drawings that contain the final dimensions and tolerances to the post-process laboratory. If the post

process must be subcontracted it is necessary to follow procedure 5.2.11 and send the part to the supplier with the drawings and all the information necessary for the post-process.

## **B. Heat treatment**

Depending on the material, heat treatments can be applied to improve some properties of the material. For instance, titanium alloys, are heat treated to reduce residual stresses caused during fabrication, to produce structural stability and optimize material properties, such as strength, fracture toughness, fatigue strength, and high-temperature creep strength.

One of the most important post treatments applied to aerospace titanium parts is Hot Isostatic Pressing (HIP). It is a process used to reduce the porosity of metals. This process improves the material ductility (% percent of elongation) and workability, and reduces the yield strength, the resilience, and the ultimate tensile strength. It is also used to increase fatigue resistance.

If post-treatments are subcontracted, the supplier has to be in compliance with the supplier procedure (Section 5.2.11) where all requirements are listed.

## **5.3.11 Powder handling, refreshing and storage**

### **Powder handling**

#### **A. Powder cleaning (I)**

After the build process and in this step, all the loose powder around the build chamber is sucked out using the vacuum cleaner.

There are two vacuum cleaners, one for the floor and another for the machine. It is absolutely forbidden to vacuum inside the machine with the floor vacuum cleaner.

- Start vacuuming when the thermocouple marks <50°C.
- Vacuum all loose powder around the build chamber and around the build.
- Elevate the manufacturing table to enable the evacuation of the start plate with the implants. Elevate in steps of 10-15 mm, vacuuming the powder after each step.



- Stop with elevation when the elevated height is close to the build height.

## **B. Powder cleaning (II)**

Finish the aspiration of the loose powder that remains inside the machine.

- Aspirate all remaining loose powder from the build chamber including small pieces of sintered powder.
- Aspirate all remaining powder from the inferior part of the machine including the pulse sensor trays and the lower floor of the machine.
- Leave the machine as clean as possible.

## **C. Sieving the powder from PRS**

Powder recovered using sandblasting is collected from the PRS and sieved in the cabinet.

- Unscrew the plug at the bottom of the PRS cyclone and pour the powder into a clean can.
- Hit the cyclone from time to time to collect as much powder as possible.
- Screw the plug again and take the can to the sieving cabinet.
- Check that the sieving cabinet is empty and clean.
- Start the sieving cabinet and pour the powder slowly from the can in order to sieve it.

## **D. Sieving the powder from the vacuum cleaner**

In this step, the powder recovered using the vacuum cleaner is collected from the PRS and sieved in the cabinet.

- Shake the lever on the lateral side of the vacuum cleaner several times in order to sediment the powder from the central conduct.
- Open the bottom deposit and take it out to the sieving cabinet.
- Start the sieving cabinet and pour the powder slowly from the can in order to sieve it.

## **Refreshing powder procedure**

Once the Production Engineer evaluates the composition of the metal (titanium alloy) in a solid part (following procedure 5.2.5) and realizes that the percentage of oxygen is out of range or if there is not enough powder to build a part, it is necessary to refresh the powder in order to reduce the percentage of oxygen.

In case of aeronautical applications where the powder is Ti6Al4V (grade 5), it is possible to reduce the percentage of Oxygen refreshing with titanium grade 23.

The procedure of the following steps:

- Weigh the recycled powder that it is out of range.
- Mix the recycled powder with fresh powder in the same amounts (based on the manufacturer's technology recommendations).
- Introduce the mixed powder in a mixing machine following the manual user of this equipment.
- Assessment of the refresh powder: Chemical composition, size distribution and fluidity/flow rate, apparent density.

Once the powder is assessed and the person responsible for the technology verifies that the powder is compliant with the standard specifications, the refreshed powder is stored and identified following procedure 5.2.5.

### **Powder storage**

#### **A. Fresh powder**

Fresh powder is received and stored according to the description in Section 5.2.5 of the General Procedures document. It should be kept in the original package and stored in a dry and cool place. It is highly recommended to equip the deposit of powder with air-conditioning and temperature control to keep the humidity below 50% and the temperature below 25°C.

#### **B. Recycled powder**

The recycled powder should be stored in the following way:

- If the build is delayed for any reason for a short period of time (2-3 days), it should be kept in the machine under Powder Protection mode.
- If there is not a build projected for a longer period of time, the powder should be stored hermetically in plastic bags under vacuum and placed in sealed deposits similar to the machine protection mode. Each deposit should be coded and related to a document in which is clearly stated:
  - The type of powder
  - Original powder batch number

- Results of the last chemical analysis

### **C. Refreshed powder**

Refreshed powder should be stored according to the description in Section 5.2.5 of the General Procedures, identifying the powder that has been mixed and its percentage.

## **5.4 Control procedures for EBM/SLM-based supply chain**

This section defines all control procedures necessary for QA during the process of AM of aerospace parts. The procedures have been written in compliance with the general guidelines of ISO 9001.

As in Section 5.3, many discussions and opinions from experts in the area of AM have been taken into account. It is very important to highlight the contribution of two partners from the RepAIR project, AIMME and the Danish TEKNOLOGISK INSTITUT.

### **5.4.1 Powder quality control**

The purchase of fresh powder is performed according to the procedure described in general procedure 5.2.4.

Once the powder is received, it is accompanied by the following documents:

- Invoice, including the purchase order, type of material and quantity of material.
- Material safety datasheet.
- Certificate of non-toxicity
- Chemical analysis report (see Appendix C, section C.3.1)

The system operator should check if the purchase order is correct and if the quantity and type of material corresponds to the ordered ones.

The Materials Consultant should also check if the chemical content of the shipped material is in accordance to the corresponding norm and valid for the application.

Thereupon, the material is registered accordingly in GP4RE01 (see Appendix C section C.1.2.)

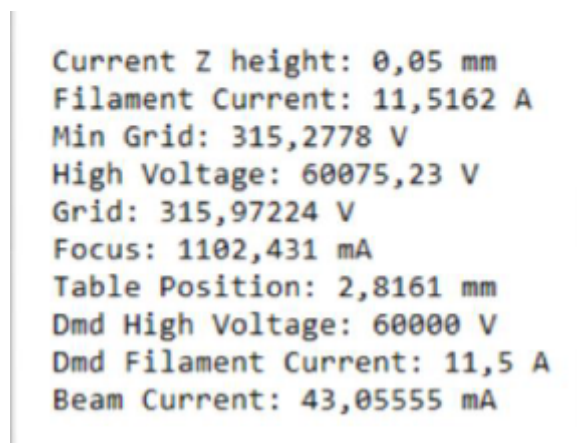
### 5.4.2 Control of the manufacturing process

The AM fabrication process is one of the key features in the production system based on AM.

#### A. EBM machine

For the EBM process, the control system is based on three main features:

1. **Status report.** It is a system message sent by the EBM systems (minimum time between two messages is 10min). In this message, the review of the critical machine parameters is made and shown to the operator. See Figure 5-8.



```
Current Z height: 0,05 mm
Filament Current: 11,5162 A
Min Grid: 315,2778 V
High Voltage: 60075,23 V
Grid: 315,97224 V
Focus: 1102,431 mA
Table Position: 2,8161 mm
Dmd High Voltage: 60000 V
Dmd Filament Current: 11,5 A
Beam Current: 43,05555 mA
```

**Figure 5-8** Status report model. EBM machine.

2. **Event report.** It is a message sent to the operator if there is an issue with the machine. The operator can correlate each “event” with the troubleshooting table in the User’s Manual and decide if the event can cause problems and if it is self-recoverable or not. See Figure 5-9.

*Example of a non-problematic self-recoverable error:* “An arc trip occurred – there was an instant interruption of the electric circuit. The machine restarts itself.”

*Example of a non-problematic error where operator has to act:* “HV contactor switched off – the electric circuit contactor went off due to e.g.

drop of the voltage. The operator has to review the build surface and re-connect the HV contactor.”

*Example of a non-recoverable error:* “Too large preheating area – the software indicates insufficient heat in the build area and has to use the maximum number of preheating repetitions. There is a problem with machine parameters which may lead to bad preheating, which will cause bad melting. Parts will be of no use.”

```
Current Z height: 1,5 mm
Filament Current: 10,96065 A
Min Grid: 328,4722 V
High Voltage: 60075,23 V
Grid: 641,66664 V
Focus: 1032,986 mA
Table Position: 8,2202 mm
Dmd High Voltage: 60000 V
Dmd Filament Current: 10,94143 A
Beam Current: 4,513889 mA
Warning
-----
09/12/2013 17:00 > Too large preheat area
```

**Figure 5-9** Event report. EBM machine.

- 3. Build report.** It is a report generated after each build on the basis of the log file. The log file is a file in which the software records all the events and the evolution of all crucial machine parameters. It also includes the build file name, overall build time, build height and other useful parameters. It represents a complete review of the build evolution. An example of the build report is shown in. Appendix D, Section D.1.1

### **SLM machine**

For the SLM process, the control system is based on three main features:

- 1. System Status Report.** At the start, and throughout a SLM build, the system sensor data can be seen and reviewed. This shows a number of different sensors that need to have an “OK” status for the build to progress. If any of the sensors show a “NOT OK” status the build will not be able to start. If there is a “NOT OK” status during a build the system

will pause the build, allowing a technician to rectify the issue. See Figure 5-10.

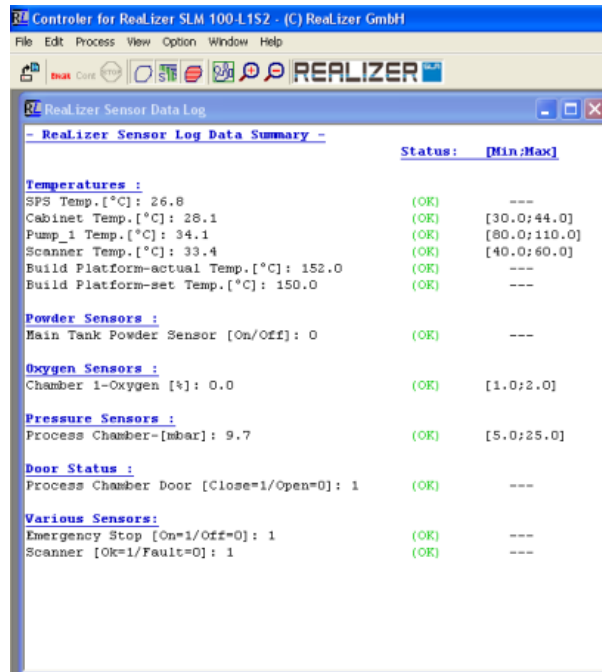
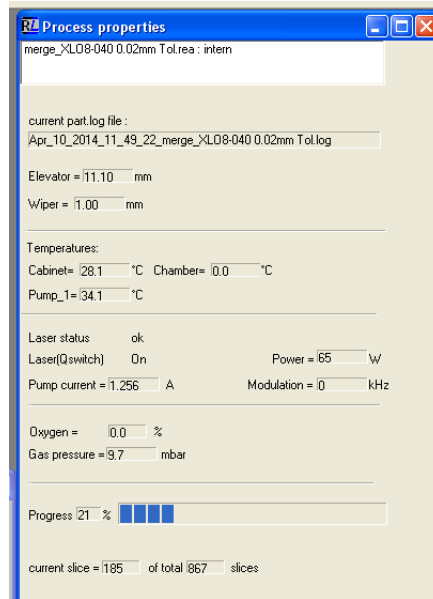


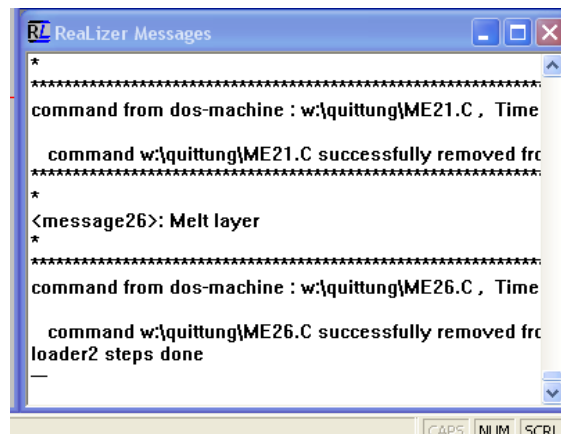
Figure 5-10 Sensor data. SLM machine.

- 2. System Progress Report.** During the build there are three message boxes that show progress and any possible faults. The first message box can be seen in Figure 5-11. This shows information concerning the builds current height and the wiper arm position, as well as, temperature status, oxygen status, pressure status and laser status. The main information that is displayed is the build % progress.



**Figure 5-11** Process properties. SLM machine

The second message box displays the commands that are sent to the system as the build is being set up/running. This can be seen in Figure 5-12. The operator can check that all processing steps are being carried out correctly. Any processing errors are shown here and the operator can relate these to the User Manual and decide if the event can cause problems and if it is self-recoverable or not.



**Figure 5-12** Message window. SLM machine.

The final message box shows information related to the optical system and scanners. These can be seen in Figure 5-13. Again, the operator can monitor these values to see if the system is operating as specified.





For this purpose, there will be a check list which will be available next to the sandblasting machine. After sandblasting the part the machine operator will have to complete the checklist. See in Annex I.

#### **5.4.4 Control of the final part**

After post-processing the part, two types of control must be made: one of the final part and another of the composition of the tester.

##### **Quality control of the tester**

As described in detail in Section 2 of the validation document, during the recycling of Ti64, there is a substantial increase of oxygen content due to humidity inside the chamber, while the aluminium decreases due to the evaporation at the build temperature. Therefore, these are two critical elements to be controlled during the recycling and consecutive builds.

The content of oxygen must be controlled after each recycling process.

Chemical analysis should be performed, not in the final part, but in the testers build for that purpose. Three testers are built for the analysis. One of these testers will be kept unaltered and it will be stored and labelled with the building plate reference in order to have a sample of the composition of the final part.

The chemical analysis should be performed following ASTM E 1409 (oxygen). The analysis results should be recorded in a table like the one shown in the Appendix C, C.3.1

##### **Quality control of the final part**

The system operator must control several parameters of the final part, especially those regarding dimensions and roughness of the part.

After post-processing the part, the system operator will be the responsible for controlling the following aspects:

- Visual control of the final part
- Accurate dimension control
- Quality surface control

- Non-destructive tests
- Destructive tests

For this purpose, a check list will be available.

## 6 Conclusions

### 6.1 Discussion of the research

Nowadays, EBM, SLM and some other AM technologies (e.g. Laser Cladding and WAAM) are widely used as a manufacturing process for metal parts in various industries. To implement them in the aerospace industry, it is necessary not only to demonstrate their manufacturing capabilities (nowadays the AM community is dedicating many resources to increasing the maturity of their technology) but also to comply with all aerospace technical and management requirements.

Incorporating AM into aerospace manufacturing or repair processes entails many issues related to “quality” that must be developed and established. Prior to developing QA/QM procedures, which include all the particularities related to the nature and characteristics of the technology, the following aspects must be achieved:

- Key factors and variables of the technology.
- Correlation between product and process specification.
- Ensure the reproducibility of the manufacturing process.

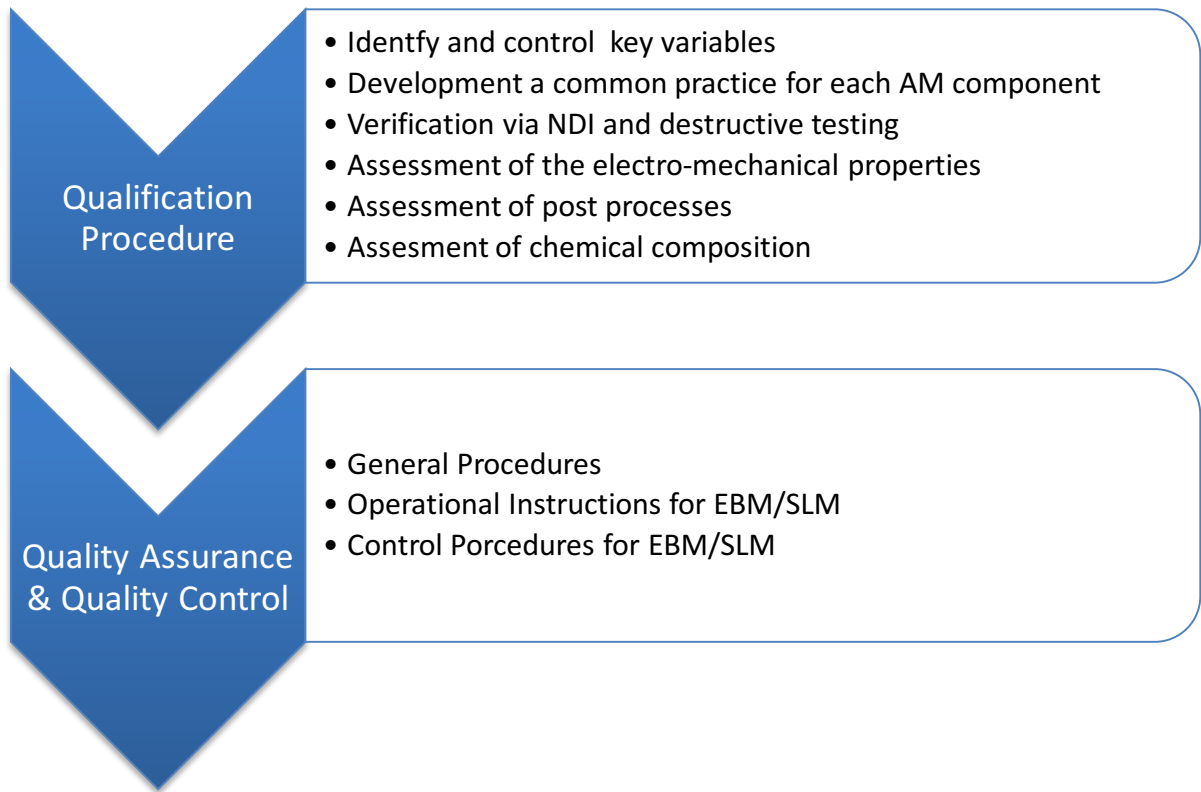
To achieve these, a new QP has been developed taking into account the particularities of both technologies, EBM and SLM, and applied to a real case study (see Chapter 4). Also, the repair supply chain of another real case has been analysed in order to identify all relevant operations that can be substituted by AM concluding with a new repair strategy. Figure 6-1 shows an overview of the QP.

Once the QP has been designed and put into practice, General Procedures, Operational Instructions, and Control Procedures related to QA/QM procedures were developed and presented for AM processes. These are the first steps to establish good manufacturing practices in order to reach the needed part’s quality.

The contributions of this research are as follows:

- A new Qualification Procedure for EBM and SLM has been defined for a real case. All critical parameters as well as their allowance range in order to have a precise control of the final parts' quality have been identified.
- A build platform for the QP has been designed taking into account previous results.
- The developed and designed QP has been applied to a real case, the Boeing bracket.
- General Procedures, Operational Instructions, and Control Procedures for EBM and SLM have been developed taking into account QA/QM aerospace requirements.
- The potential risks as well as their impact on the Quality System have been defined.
- All the necessary registers related with these procedures have been developed and included (see Appendix C)
- Relevant performance indicators have been proposed to evaluate each procedure's efficiency.

These constitute the first steps to certify manufactured or repaired parts in the aerospace industry, which must be the ultimate goal.



**Figure 6-1** Qualification procedure overview.

## 6.2 Future work

From a quality point of view, this thesis represents the first steps towards a consistent set of QA/QM procedures that comply with all management, control and assurance requirements in the aerospace industry. However, there are quality issues that need to be resolved before implementing AM as a manufacturing or repair technology.

- Standardization is not well established. As has mentioned in Section 2.8, there are many committees working to overcome this challenge. The ASTM Committee is probably the most advanced in this respect.
- New advanced NDT techniques capable of detecting critical defects with a high degree of certainty.
- To process more complex parts (like the HPT shroud or blade) new materials, like Rene 95 or N500, need to be processed with this technology. Proper operating windows for each machine and new materials must be established.
- Final accuracy and surface finish must be improved in order to avoid additional post-processes. These affect the economic advantages of these technologies.
- New on-process quality systems need to be implemented in order to verify in each layer some particular quality aspects, including porosity, lack of fusion and accuracy amongst others.

## REFERENCES

- [1] Khajavi, S. H., Partanen, J. and Holmström, J. (2014) "Additive manufacturing in the spare parts supply chain", *Computers in Industry*, vol. 65, no. 1, pp. 50-63.
- [2] Ingomar Kelbassa, Patrick Albus, Jens Dietrich, Jan Wilkens (2008) "Manufacture and Repair of Aero Engine Components Using Laser Technology", *Proceedings of the 3<sup>rd</sup> Pacific International Conference on Application of Lasers and Optics (PICALO) 2008*, Beijing, China, pp. 208.
- [3] Mellor, S., Hao, L. and Zhang, D. (2014) "Additive manufacturing: A framework for implementation", *International Journal of Production Economics*, vol. 149, pp. 194-201.
- [4] EASA-European Aviation Safety Agency (2013) *Certification Specifications and Acceptable Means of Compliance for Large Aeroplanes, CS-25*, Publications Office of the European Union, Luxembourg.
- [5] B. Lyons (2012) "Additive Manufacturing in Aerospace: Examples and Research Outlook", *The Bridge*, vol. 42, no. 1.
- [6] Wissenbach, K. (2007) "Flexible and Near-Net-Shape Generative Manufacturing Chains and Repair Techniques for Complex Shaped Aero Engines parts", 13361, European Commission, Germany.
- [7] Bourell, D. L., Beaman, J. B., Leu, M. C. and Rosen, D. W. (2011) "A Brief History of Additive Manufacturing and the 2009 Roadmap for Additive Manufacturing: Looking Back and Looking Ahead", *RapidTech: US-Turkey Workshop on Rapid Technologies*, Instabul Technical University and Tennessee Technological University.
- [8] Gasser, A., Backes, G., Kelbassa, I., Weisheit, A. and Wissenbach, K. (2010) "Laser additive manufacturing. Laser Metal Deposition (LMD) and Selective Laser Melting (SLM) in turbo-engine applications", *Laser Technik Journal*, vol. 7, no. 2, pp. 58-63.
- [9] Arcella, F. and Froes, F. H. (2000) "Producing titanium aerospace components from powder using laser forming", *JOM*, vol. 52, no. 5, pp. 28-30.
- [10] The Economist, ( 2012) "Solid print: Making things with a 3D printer changes the rules of manufacturing", Economist, London.

- [11] G. Deppe and R. Koch (2014) "Exploring the influence on an additive manufacturing integration on future MRO processes in aeronautics", *RapidTech*, 15 May 2014, Erfurt, Universität Paderborn, .
- [12] Groneck, D. and Harmon, D. (2003) "Design development of unitized titanium structure", *Journal of Engineering for Gas Turbines and Power*, vol. 125, no. 1, pp. 252-256.
- [13] Wood, D., ( 2009) "Additive manufacturing at AIRBUS-Reality check or view into the future?", 17th ed., TCT Megazine.
- [14] Atzeni, E. and Salmi, A. (2012) "Economics of additive manufacturing for end-useable metal parts", *International Journal of Advanced Manufacturing Technology*, vol. 62, no. 9-12, pp. 1147-1155.
- [15] Wang, Y., Luo, Z., Zhang, N. and Kang, Z. (2014) "Topological shape optimization of microstructural metamaterials using a level set method", *Computational Materials Science*, vol. 87, pp. 178-186.
- [16] Karma(2013), available at: <http://www.karmaproject.eu> (accessed 04/15).
- [17] CoAMPIY, available at: <http://dmrc.uni-paderborn.de/fileadmin/dmrc/Projects/CoAMPLy.pdf>.
- [18] Compolight(2014), available at: <http://compolight.dti.dk/> (accessed 15/04/2014).
- [19] Chua, C. K., Leong, K. F. and Lim, C. S. (2010) "Rapid Prototyping : Principles and Applications", 3<sup>rd</sup> edition, World Scientific Publishing, US.
- [20] William E. Frazier (2010) "Direct Digital Manufacturing of Metallic Components: Vision and Roadmap", 21<sup>st</sup>, *International Solid Freeform Fabrication Symposium*, University of Texas , Austin, pp. 717-732.
- [21] Committee F42, A., ( 2012) *F2792 -12a: Standard Terminology for Additive Manufacturing Technologies*, F2792 -12a ed., ASTM.
- [22] Levy, G. N., Schindel, R. and Kruth, J. P. (2003) "Rapid manufacturing and rapid tooling with Layer Manufacturing (LM) technologies, state of the art and future perspectives", *CIRP Annals - Manufacturing Technology*, vol. 52, no. 2, pp. 589-609.
- [23] Gibson, I., Rosen, D. W. and Brent, S. (2010) *Additive Manufacturing Technologies: Rapid Prototyping to Direct Digital Manufacturing*, Springer, New York ; London.



- [24] Rudgley, M. (2001) "Rapid Manufacturing - The Revolution is Beginning", *Proceedings of the uRapid 2001*, May 2001, Amsterdam, Netherlands, uRapid 2001, pp. 441.
- [25] West, A. P., Sambu, S. P. and Rosen, D. W. (2001) "A process planning method for improving build performance in stereolithography", *Computer-Aided Design*, vol. 33, no. 1, pp. 65-79.
- [26] Bontha, S., Klingbeil, N. W., Kobryn, P. A. and Fraser, H. L. (2009) "Effects of process variables and size-scale on solidification microstructure in beam-based fabrication of bulky 3D structures", *Materials Science and Engineering: A*, vol. 513–514, pp. 311-318.
- [27] Kruf, W., van de Vorst, B., Maalderink, H. and Kamperman, N. (2006) "Design for Rapid Manufacturing functional SLS parts", in Pham, D. T., Eldukhri, E. E. and Soroka, A. J. (eds.) *Intelligent Production Machines and Systems*, Elsevier Science Ltd, Oxford, pp. 389.
- [28] Yadroitsev, I. and Smurov, I. (2011) "Surface Morphology in Selective Laser Melting of Metal Powders", *Physics Procedia*, vol. 12, Part A, pp. 264-270.
- [29] Sun, J., Yang, Y. and Wang, D. (2013) "Mechanical properties of a Ti6Al4V porous structure produced by selective laser melting", *Materials & Design*, vol. 49, pp. 545-552.
- [30] Ramirez, D. A., Murr, L. E., Martinez, E., Hernandez, D. H., Martinez, J. L., Machado, B. I., Medina, F., Frigola, P. and Wicker, R. B. (2011) "Novel precipitate–microstructural architecture developed in the fabrication of solid copper components by additive manufacturing using electron beam melting", *Acta Materialia*, vol. 59, no. 10, pp. 4088-4099.
- [31] Murr, L. E., Esquivel, E. V., Quinones, S. A., Gaytan, S. M., Lopez, M. I., Martinez, E. Y., Medina, F., Hernandez, D. H., Martinez, E., Martinez, J. L., Stafford, S. W., Brown, D. K., Hoppe, T., Meyers, W., Lindhe, U. and Wicker, R. B. (2009) "Microstructures and mechanical properties of electron beam-rapid manufactured Ti–6Al–4V biomedical prototypes compared to wrought Ti–6Al–4V", *Materials Characterization*, vol. 60, no. 2, pp. 96-105.
- [32] Li, J., Yu, Z. and Wang, H. (2011) "Wear behaviors of an (TiB+TiC)/Ti composite coating fabricated on Ti6Al4V by laser cladding", *Thin Solid Films*, vol. 519, no. 15, pp. 4804-4808.
- [33] Kazanas, P., Deherkar, P., Almeida, P., Lockett, H. and Williams, S. (2012) "Fabrication of geometrical features using wire and arc additive manufacture", *Proceedings of the Institution of Mechanical Engineers, Part B: Journal of Engineering Manufacture*, vol. 226, no. 6, pp. 1042-1051.

- [34] Sampedro, J., Pérez, I., Carcel, B., Ramos, J. A. and Amigó, V. (2011) "Laser Cladding of TiC for Better Titanium Components", *Physics Procedia*, vol. 12, Part A, pp. 313-322.
- [35] P. Kobryn, N. Ontko, L. Perkins and J. Tiley. (2006) "Additive Manufacturing of Aerospace Alloys for Aircraft Structures", *Meeting Proceedings RTO-MP-AVT-139*, 15-17 May 2006, Amsterdam, Netherlands, RTO, Neuilly-sur-Seine, France, .
- [36] Gu, D. D., Meiners, W., Wissenbach, K. and Poprawe, R. (2012) "Laser additive manufacturing of metallic components: materials, processes and mechanisms", *International Materials Reviews*, vol. 57, no. 3, pp. 133-164.
- [37] Tim Caffrey, T. W. (2013) "Wohlers Report 2013",. Executive Summary.
- [38] Holmstrom, J., Partanen, J., Tuomi, J. and Walter, M. (2010) "Rapid manufacturing in the spare parts supply chain: alternative approaches to capacity deployment", *Journal of Manufacturing Technology Management*, vol. 21, no. 6, pp. 687-697.
- [39] White. D, ( 2003) *Ultrasonic Object Consolidation*, 6,519,500 B1 ed., US.
- [40] Murr, L. E., Martinez, E., Gaytan, S. M., Ramirez, D. A., Machado, B. I., Shindo, P. W., Martinez, J. L., Medina, F., Wooten, J., Ciscel, D., Ackelid, U. and Wicker, R. B. (2011) "Microstructural Architecture, Microstructures, and Mechanical Properties for a Nickel-Base Superalloy Fabricated by Electron Beam Melting", *Metallurgical and Materials Transactions A*, vol. 42, no. 11, pp. 3491-3508.
- [41] Thijs, L., Verhaeghe, F., Humbeeck, J. V., Craeghs, T. and Kruth, J. -. (2010) "A study of the microstructural evolution during selective laser melting of Ti-6Al-4V", *Acta Materialia*, vol. 58, no. 9, pp. 3303-3312.
- [42] Steen, W. M. and Mazumder, J. (2010) *Laser Material Processing*, 4<sup>th</sup> ed, Springer, London; New York.
- [43] Otto, A. and Schmidt, M. (2010) "Towards a universal numerical simulation model for laser material processing", *Physics Procedia*, vol. 5, pp. 35-46.
- [44] Zäh, M. F. and Lutzmann, S. (2010) "Modelling and simulation of electron beam melting", *Production Engineering*, vol. 4, no. 1, pp. 15-23.
- [45] Zhou, J., Zhang, Y. and Chen, J. K. (2009) "Numerical simulation of laser irradiation to a randomly packed bimodal powder bed", *International Journal of Heat and Mass Transfer*, vol. 52, no. 13-14, pp. 3137-3146.

- [46] Lacki, P. and Adamus, K. (2011), "Numerical simulation of the electron beam welding process", *Computers & Structures*, vol. 89, no. 11–12, pp. 977-985.
- [47] , Arcam AB(2014), available at: <http://www.arcam.com/> (accessed 04/29).
- [48] Santamaría de las Cuevas, F. and San José Santamaría, I. (1993), *La Tecnología de Haz de Electrones y sus Aplicaciones*, McGraw-Hill, Madrid.
- [49] Murr, L. E., Gaytan, S. M., Ramirez, D. A., Martinez, E., Hernandez, J., Amato, K. N., Shindo, P. W., Medina, F. R. and Wicker, R. B. (2012) "Metal Fabrication by Additive Manufacturing Using Laser and Electron Beam Melting Technologies", *Journal of Materials Science & Technology*, vol. 28, no. 1, pp. 1-14.
- [50] Murr, L. E., Martinez, E., Pan, X. M., Gaytan, S. M., Castro, J. A., Terrazas, C. A., Medina, F., Wicker, R. B. and Abbott, D. H. (2013) "Microstructures of Rene 142 nickel-based superalloy fabricated by electron beam melting", *Acta Materialia*, vol. 61, no. 11, pp. 4289-4296.
- [51] Murr, L. E., Quinones, S. A., Gaytan, S. M., Lopez, M. I., Rodela, A., Martinez, E. Y., Hernandez, D. H., Martinez, E., Medina, F. and Wicker, R. B. (2009) "Microstructure and mechanical behavior of Ti–6Al–4V produced by rapid-layer manufacturing, for biomedical applications", *Journal of the Mechanical Behavior of Biomedical Materials*, vol. 2, no. 1, pp. 20-32.
- [52] Ding, J., Mehnen, J., Colegrove, P., Ganguly, S., Almeida, P. M. S., Wang, F. and Williams, S. (2011) "Thermo-mechanical analysis of Wire and Arc Additive Layer Manufacturing process on large multi-layer parts", *Computational Materials Science*, vol. 50, no. 12, pp. 3315-3322.
- [53] Rios Contesse, S. E., Williams, S. and Wang, F. (2013) *Plasma Torch Design for Wire and Arc Additive Manufacturing (WAAM) titanium alloy* (M.Sc. thesis), Cranfield University, School of Applied Sciences.
- [54] Sequeira Almeida, P. M. and Williams, S. (2012) *Process Control and Development in Wire and Arc Additive Manufacturing* (PhD thesis), Cranfield University, School of Applied Sciences.
- [55] A. W. Hammeke, ( 1988) *Laser Spray Nozzle and Method*, 4727299th ed., US.
- [56] Shiomi, M., Osakada, K., Nakamura, K., Yamashita, T. and Abe, F. (2004) "Residual stress within metallic model made by selective laser melting process", *CIRP Annals - Manufacturing Technology*, vol. 53, no. 1, pp. 195-198.

- [57] Mercelis, P. and Kruth, J. P. (2006) "Residual stresses in selective laser sintering and selective laser melting", *Rapid Prototyping Journal*, vol. 12, no. 5, pp. 254-265.
- [58] Ding, J. and Williams, S. (2012) *Thermo-Mechanical Analysis of Wire and Arc Additive Manufacturing Process*, Cranfield University, School of Applied Science.
- [59] Zheng, B., Zhou, Y., Schoenung, J. M., Lavernia, E. J. and Smugeresky, J. E. (2008) "Thermal behavior and microstructural evolution during laser deposition with laser-engineered net shaping: Part I. Numerical calculations", *Metallurgical and Materials Transactions A: Physical Metallurgy and Materials Science*, vol. 39, no. 9, pp. 2228-2236.
- [60] Zheng, B., Zhou, Y., Schoenung, J. M., Lavernia, E. J. and Smugeresky, J. E. (2008) "Thermal behavior and microstructure evolution during laser deposition with laser-engineered net shaping: Part II. Experimental investigation and discussion", *Metallurgical and Materials Transactions A: Physical Metallurgy and Materials Science*, vol. 39, no. 9, pp. 2237-2245.
- [61] Mudge, R. P. and Wald, N. R. (2007) "Laser engineered net shaping advances additive manufacturing and repair", *Welding Journal (Miami, Fla)*, vol. 86, no. 1, pp. 44-48.
- [62] Brodin, H., Andersson, O. and Johansson, S. (2013) "Mechanical testing of a selective laser melted superalloy", *13th International Conference on Fracture*, June 2013, Beijing, China, Sweden, pp. 1.
- [63] Luca, F., Emanuele, M., Pierfrancesco, R., Alberto, M., Simon, H. and Konrad, W. (2010) "Ductility of a Ti-6Al-4V alloy produced by selective laser melting of prealloyed powders", *Rapid Prototyping Journal*, vol. 16, no. 6, pp. 450-459.
- [64] Luca, F., Emanuele, M., Pierfrancesco, R. and Alberto, M. (2009) "Microstructure and mechanical properties of Ti-6Al-4V produced by electron beam melting of pre-alloyed powders", *Rapid Prototyping Journal*, vol. 15, no. 3, pp. 171-178.
- [65] Murr, L. E., Gaytan, S. M., Ceylan, A., Martinez, E., Martinez, J. L., Hernandez, D. H., Machado, B. I., Ramirez, D. A., Medina, F., Collins, S. and Wicker, R. B. (2010) "Characterization of titanium aluminide alloy components fabricated by additive manufacturing using electron beam melting", *Acta Materialia*, vol. 58, no. 5, pp. 1887-1894.
- [66] Vrancken, B., Thijs, L., Kruth, J. -. and Van Humbeeck, J. (2014) "Microstructure and mechanical properties of a novel  $\beta$  titanium metallic composite by selective laser melting", *Acta Materialia*, vol. 68, no. 0, pp. 150-158.

- [67] Koike, M., Martinez, K., Guo, L., Chahine, G., Kovacevic, R. and Okabe, T. (2011) "Evaluation of titanium alloy fabricated using electron beam melting system for dental applications", *Journal of Materials Processing Technology*, vol. 211, no. 8, pp. 1400-1408.
- [68] Nijdam, T. J. and van Gester, R. (2011) *Service Experience with Single Crystal Superalloys for High Pressure Turbine Shrouds*, NLR-TP-2011-547, National Aerospace Laboratory NLR, 2011, Nationaal Lucht- en Ruimtevaartlaboratorium.
- [69] Strondl, A., Fischer, R., Frommeyer, G. and Schneider, A. (2008) "Investigations of MX and  $\gamma'/\gamma$ " precipitates in the nickel-based superalloy 718 produced by electron beam melting", *Materials Science and Engineering: A*, vol. 480, no. 1–2, pp. 138-147.
- [70] Frazier, W. E. (2014) "Metal Additive Manufacturing: A Review", *Journal of Materials Engineering and Performance*, vol. 23, no. 6, pp. 1917-1928.
- [71] Greitemeir, D., Schmidtke, K., Holzinger, V. and Donne, C. D. (2012) "Additive Layer Manufacturing of Ti-6Al-4V and ScalmalloyRP Fatigue and Fracture", in Sérgio M.O. Tavares (ed.) *1<sup>st</sup> International Conference of the International Journal of Structural Integrity*, June, Faculty of Engineering, University of Oporto, Publindústria, Portugal, pp. 11.
- [72] Mazumder, J., Dutta, D., Kikuchi, N. and Ghosh, A. (2000) "Closed loop direct metal deposition: art to part", *Optics and Lasers in Engineering*, vol. 34, no. 4–6, pp. 397-414.
- [73] N. T. Nguyen, A. Ohta, K. Matsuoka, N. Suzuki, Y. Maeda (1999) "Analytical Solutions for Transient Temperature of Semi-Infinite Body Subjected to 3-D Moving Heat Sources", *Welding Journal*, , no. Supplement, pp. 265-274.
- [74] Beuth, J. and Klingbeil, N. (2001) "The role of process variables in laser-based direct metal solid freeform fabrication", *JOM*, vol. 53, no. 9, pp. 36-39.
- [75] Negi, V. and Chattopadhyaya, S. (2013) "Critical Assessment of Temperature Distribution in Submerged Arc Welding Process", *Advances in Materials Science and Engineering*, vol. 2013, no. Article ID 543594, pp. 1-9.
- [76] Zhang, Y. and Faghri, A. (1999) "Melting of a subcooled mixed powder bed with constant heat flux heating", *International Journal of Heat and Mass Transfer*, vol. 42, no. 5, pp. 775-788.

- [77] Verhaeghe, F., Craeghs, T., Heulens, J. and Pandelaers, L. (2009) "A pragmatic model for selective laser melting with evaporation", *Acta Materialia*, vol. 57, no. 20, pp. 6006-6012.
- [78] Rosenthal, D. (1946) "The theory of Moving Sources of Heat and its Application to Metal Treatments.", *Transactions of ASME*, vol. 68, pp. 849-866.
- [79] Gürtler, F. J., Karg, M., Leitz, K. H. and Schmidt, M. (2013) "Simulation of Laser Beam Melting of Steel Powders using the Three-Dimensional Volume of Fluid Method", *Physics Procedia*, vol. 41, pp. 881-886.
- [80] Chen, T. and Zhang, Y. (2004) "Numerical Simulation of Two-Dimensional Melting and Resolidification of a Two-Component Metal Powder Layer in Selective Laser Sintering Process", *Numerical Heat Transfer: Part A - Applications*, vol. 46, no. 7, pp. 633-649.
- [81] Xiao, B. and Zhang, Y. (2008) "Numerical Simulation of Direct Metal Laser Sintering of Single-Component Powder on Top of Sintered Layers", *Journal of Manufacturing Science and Engineering*, vol. 130, no. 4, pp. 041002-041002.
- [82] Gusarov, A. V., Yadroitsev, I., Bertrand, P. and Smurov, I. (2007) "Heat transfer modelling and stability analysis of selective laser melting", *Applied Surface Science*, vol. 254, no. 4, pp. 975-979.
- [83] Tushar Ramkrishna Mahale (2009) *Electron Beam Melting of Advanced Materials and Structures*, Faculty of North Carolina State University
- [84] Klassen, A., Bauereiß, A. and Körner, C. (2014) "Modelling of electron beam absorption in complex geometries", *Journal of Physics D: Applied Physics*, vol. 47, no. 6, pp. 1-11.
- [85] Jamshidinia, M., Kong, F. and Kovacevic, R. (2013) "The Coupled CFD-FEM Model of Electron Beam Melting (EBM)", *ASME Distric F-Early Career Technical Confeence*, vol. 12, 2-3 November, Dallas, Texas US, SMU Digital Repository, Southern Methodist University, pp. 163-171.
- [86] Peyre, P., Fabbro, R., Neveu, R., Aubry, P. and Longuet, A. (2008) "Analytical and numerical modelling of the direct metal deposition laser process", *Journal of Physics D: Applied Physics*, vol. 41, pp. 1-10.
- [87] Ye, R., Smugeresky, J. E., Zheng, B., Zhou, Y. and Lavernia, E. J. (2006) "Numerical modeling of the thermal behavior during the LENS® process", *Materials Science and Engineering: A*, vol. 428, no. 1-2, pp. 47-53.

- [88] Alimardani, M., Toyserkani, E. and Huissoon, J. P. (2007) "A 3D dynamic numerical approach for temperature and thermal stress distributions in multilayer laser solid freeform fabrication process", *Optics and Lasers in Engineering*, vol. 45, no. 12, pp. 1115-1130.
- [89] Michaleris, P. (2014), "Modeling metal deposition in heat transfer analyses of additive manufacturing processes", *Finite Elements in Analysis and Design*, vol. 86, pp. 51-60.
- [90] Körner, C., Attar, E. and Heini, P. (2011) "Mesoscopic simulation of selective beam melting processes", *Journal of Materials Processing Technology*, vol. 211, no. 6, pp. 978-987.
- [91] Dorr, M. R., Fattebert, J. L., Wickett, M. E., Wickett, M. E. and Turchi, P. E. A. (2010) "A numerical algorithm for the solution of a phase-field model of polycrystalline materials", *Journal of Computational Physics*, vol. 229, no. 3, pp. 626-641.
- [92] Gandin, C. -, Desbiolles, J. -, Rappaz, M. and Thevoz, P. (1999) "A three-dimensional cellular automaton-finite element model for the prediction of solidification grain structures", *Metallurgical and Materials Transactions A*, vol. 30, no. 12, pp. 3153-3165.
- [93] De Florio, F. (2006) *Airworthiness : An Introduction to Aircraft Certification: a Guide to Understanding JAA, EASA, and FAA Standards*, 1st ed, Butterworth-Heinemann, Oxford.
- [94] Federal Aviation Administration (2014) *FAA*, available at: <http://www.faa.gov/> (accessed 05/07/2014).
- [95] EASA-European Aviation Safety Agency ( 2003) *Regulation (EC) No 2042/2003*, Basic ed.
- [96] EASA-European Aviation Safety Agency (2012) *Part-145, Maintenance Organisation Approvals*, Publication Office of the European Union, Luxembourg.
- [97] EASA-European Aviation Safety Agency (ed.) (2012), *Part-66, Certifying Staff*, Publications Office of the European Union, Luxembourg.
- [98] EASA-European Aviation Safety Agency (2003) *Part-147, Training Organization Requirements*, Luxembourg, Publications Office of the European Union.
- [99] EASA-European Aviation Safety Agency (2013) *Part-21, Airworthiness and Environmental Certification*, Publications Office of the European Union, Luxembourg.

- [100] Committee F42, A. (2014) *Committee F42 on Additive Manufacturing Technologies*, available at: <http://www.astm.org/COMMITTEE/F42.htm> (accessed 19/05/2014).
- [101] Committee F42, A., ( 2014) *F2924-14: Standard Specification for Additive Manufacturing Titanium-6 Aluminium-4 Vanadium with Powder Bed Fusion*, F2924-14 ed., ASTM.
- [102] Committee F42, A., ( 2014) *F3001-14: Standard Specification for Additive Manufacturing Titanium-6 Aluminum-4 Vanadium ELI (Extra Low Interstitial) with Powder Bed Fusion*, F3001-14 ed., ASTM.
- [103] Committee F42, A., ( 2013) *F2971-13: Standard Practice for Reporting Data for Test Specimens Prepared by Additive Manufacturing*, F2971-13 ed., ASTM.
- [104] Committee F42, A., ( 2013) *ISO/ASTM 52921:2013(E) Standard Terminology for Additive Manufacturing- Coordinate System and Test Methodologies*, ISO/ASTM 52921:2013(E) ed., ASTM.
- [105] EASA-European Aviation Safety Agency, ( 2012) *Acceptable Means of Compliance and Guidance Material to Part 21*.
- [106] Maher, M., ( 2012) *Brief Presented at the SAMPLE Direct Part Manufacturing Workshop*, Open Manufacturing, Dayton OH.
- [107] Juechter, V., Scharowsky, T., Singer, R. F. and Körner, C. (2014) "Processing window and evaporation phenomena for Ti-6Al-4V produced by selective electron beam melting", *Acta Materialia*, vol. 76, no. 0, pp. 252-258.
- [108] Thijs, L., Montero Sistiaga, M. L., Wauthle, R., Xie, Q., Kruth, J. and Van Humbeeck, J. (2013) "Strong morphological and crystallographic texture and resulting yield strength anisotropy in selective laser melted tantalum", *Acta Materialia*, vol. 61, no. 12, pp. 4657-4668.
- [109] Xibing Gong, Ted Anderson, and Kevin Chou (2014) "Review on powder-based electron beam additive manufacturing technology", *EDP Sciences*, .
- [110] Uriondo, A., Esperon-Miguez, M. and Perinpanayagam, S. (2015) "The present and future of additive manufacturing in the aerospace sector: a review of important aspects", *Proceedings of the Institution of Mechanical Engineers, Part G: Journal of Aerospace Engineering*, (Accepted on 12/2014, online version: [:http://pig.sagepub.com/content/early/2015/01/28/0954410014568797](http://pig.sagepub.com/content/early/2015/01/28/0954410014568797))

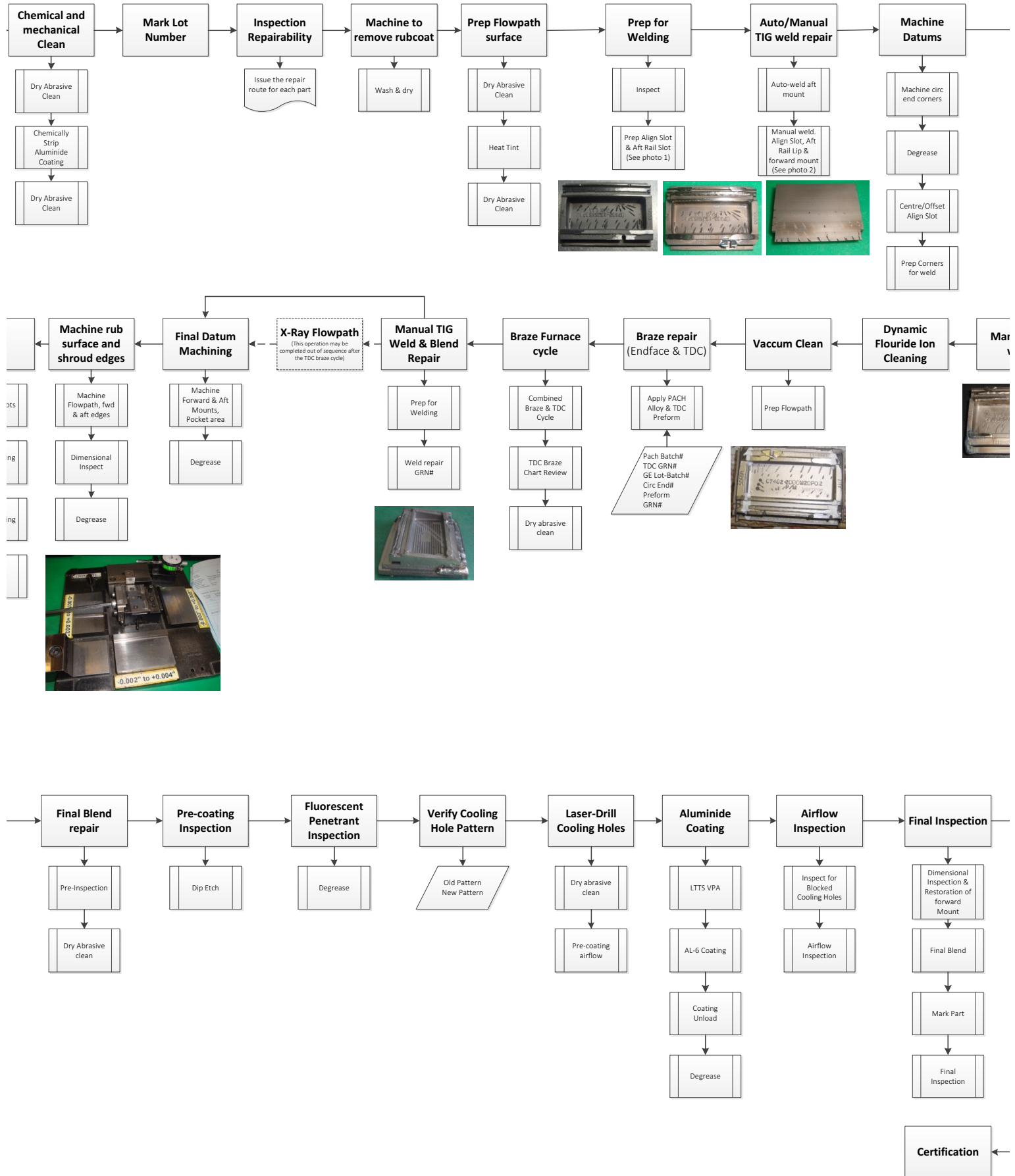


- [111] ISO/TC 176/SC 2, ( 2008) *Quality Management Systems-- Requirements.*
- [112] ISO/TC 176/SC 1, ( 2005) *Quality Management Systems -- Fundamentals and vocabulary.*
- [113] ISO/TC 20, ( 2010) *Quality Management Systems-Requirements for Aviation, Space, and Defense Organizations.*
- [114] Asociación Española de Normalización y Certificación (2006) *UNE-EN 9110: material aeroespacial : sistemas de gestión de la calidad : modelo para el aseguramiento de la calidad aplicable a organizaciones de mantenimiento*, Aenor, Madrid.
- [115] EASA-European Aviation Safety Agency (2012) *Part-M, Continuing Airworthiness Requirements*, Publications Office of the European Union, Luxembourg.
- [116] Price, S., Lydon, J., Cooper, K. and Chou, K. (2013) "Experimental temperature analysis of powder-based electron-beam additive manufacturing", *24<sup>th</sup> Annual International Solid Freeform Fabrication Symposium*, August 12-14, Austin, TX, pp. 162-173.

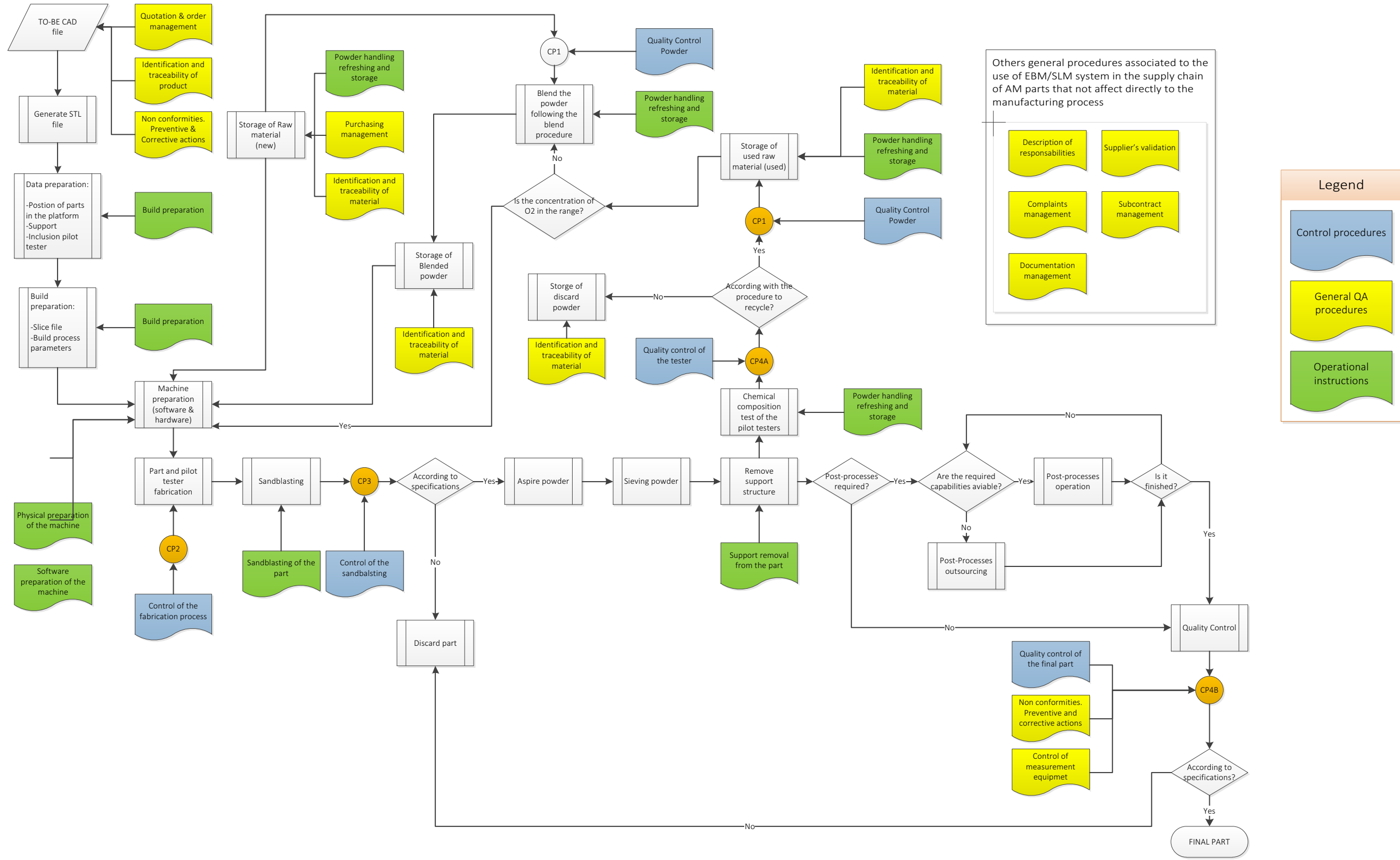


# IDICES

## Part A Current repair process for the HTP Shroud CFM56 -2/3



# Appendix B Process flowchart



# Appendix C Registers

## C.1 General Procedures

### C.1.1 GP2RE01. List of Build Files

|                     |                  |
|---------------------|------------------|
| LIST OF BUILD FILES | REGISTER:GP2RE01 |
|                     | DATE: 11/13      |
|                     | VERSION: 1       |
|                     | MODIFICATION:    |

| BUILD FILE CODE: |                  |
|------------------|------------------|
| PART NAME        | QUOTATION NUMBER |
|                  |                  |
|                  |                  |
|                  |                  |
|                  |                  |
|                  |                  |
|                  |                  |
|                  |                  |
|                  |                  |
|                  |                  |

### C.1.2 GP4RE01. Checklist of Fresh Powder Reception

|                                     |                  |
|-------------------------------------|------------------|
| CHECKLIST OF FRESH POWDER RECEPTION | REGISTER:GP4RE01 |
|                                     | DATE: 11/13      |
|                                     | VERSION: 1       |
|                                     | MODIFICATION:    |

| Internal purchase order | Quotation number            | Correct purchase order reference | Chemical analysis attached  | System operator signature | Materials consultant signature | Comments |
|-------------------------|-----------------------------|----------------------------------|-----------------------------|---------------------------|--------------------------------|----------|
|                         | <input type="checkbox"/> OK | <input type="checkbox"/> OK      | <input type="checkbox"/> OK |                           |                                |          |
|                         | <input type="checkbox"/> OK | <input type="checkbox"/> OK      | <input type="checkbox"/> OK |                           |                                |          |
|                         | <input type="checkbox"/> OK | <input type="checkbox"/> OK      | <input type="checkbox"/> OK |                           |                                |          |
|                         | <input type="checkbox"/> OK | <input type="checkbox"/> OK      | <input type="checkbox"/> OK |                           |                                |          |
|                         | <input type="checkbox"/> OK | <input type="checkbox"/> OK      | <input type="checkbox"/> OK |                           |                                |          |
|                         | <input type="checkbox"/> OK | <input type="checkbox"/> OK      | <input type="checkbox"/> OK |                           |                                |          |
|                         | <input type="checkbox"/> OK | <input type="checkbox"/> OK      | <input type="checkbox"/> OK |                           |                                |          |
|                         | <input type="checkbox"/> OK | <input type="checkbox"/> OK      | <input type="checkbox"/> OK |                           |                                |          |
|                         | <input type="checkbox"/> OK | <input type="checkbox"/> OK      | <input type="checkbox"/> OK |                           |                                |          |

### C.1.3 GP5RE01. Measuring Equipment List

|                                 |                  |
|---------------------------------|------------------|
| <b>MEASURING EQUIPMENT LIST</b> | REGISTER:GP5RE01 |
|                                 | DATE: 11/13      |
|                                 | VERSION: 1       |
|                                 | MODIFICATION:    |

| MEASURING EQUIPMENT LIST |      |                    |                        |          |
|--------------------------|------|--------------------|------------------------|----------|
| Code                     | Name | Calibration period | Calibration laboratory | Comments |
|                          |      |                    |                        |          |
|                          |      |                    |                        |          |
|                          |      |                    |                        |          |
|                          |      |                    |                        |          |
|                          |      |                    |                        |          |
|                          |      |                    |                        |          |
|                          |      |                    |                        |          |
|                          |      |                    |                        |          |
|                          |      |                    |                        |          |

### C.1.4 GP6RE01. Training Requirements

|                              |                  |
|------------------------------|------------------|
| <b>TRAINING REQUIREMENTS</b> | REGISTER:GP6RE01 |
|                              | DATE: 11/13      |
|                              | VERSION: 1       |
|                              | MODIFICATION:    |

|                                    |      |
|------------------------------------|------|
| <b>PROFILE: TECHNOLOGY MANAGER</b> |      |
| MINIMUM QUALIFICATION              |      |
|                                    |      |
| SPECIFIC REQUIREMENTS              |      |
|                                    |      |
| MINIMUM EXPERIENCE REQUIRED        |      |
| YEARS                              | TYPE |
|                                    |      |
|                                    |      |
| OTHER REQUIRED ASPECTS             |      |
|                                    |      |
|                                    |      |
|                                    |      |

|                                 |      |
|---------------------------------|------|
| <b>PROFILE: QUOTATION AGENT</b> |      |
| MINIMUM QUALIFICATION           |      |
|                                 |      |
| SPECIFIC REQUIREMENTS           |      |
|                                 |      |
| MINIMUM EXPERIENCE REQUIRED     |      |
| YEARS                           | TYPE |
|                                 |      |
|                                 |      |
| OTHER REQUIRED ASPECTS          |      |
|                                 |      |
|                                 |      |
|                                 |      |

|                                 |      |  |  |
|---------------------------------|------|--|--|
| <b>PROFILE: SYSTEM OPERATOR</b> |      |  |  |
| MINIMUM QUALIFICATION           |      |  |  |
|                                 |      |  |  |
| SPECIFIC REQUIREMENTS           |      |  |  |
|                                 |      |  |  |
| MINIMUM EXPERIENCE REQUIRED     |      |  |  |
| YEARS                           | TYPE |  |  |
|                                 |      |  |  |
|                                 |      |  |  |
| OTHER REQUIRED ASPECTS          |      |  |  |
|                                 |      |  |  |
|                                 |      |  |  |
|                                 |      |  |  |

|                                     |      |  |  |
|-------------------------------------|------|--|--|
| <b>PROFILE: MATERIAL CONSULTANT</b> |      |  |  |
| MINIMUM QUALIFICATION               |      |  |  |
|                                     |      |  |  |
| SPECIFIC REQUIREMENTS               |      |  |  |
|                                     |      |  |  |
| MINIMUM EXPERIENCE REQUIRED         |      |  |  |
| YEARS                               | TYPE |  |  |
|                                     |      |  |  |
|                                     |      |  |  |
| OTHER REQUIRED ASPECTS              |      |  |  |
|                                     |      |  |  |
|                                     |      |  |  |
|                                     |      |  |  |

### C.1.5 GP6RE02. Training Planning

|                          |                  |
|--------------------------|------------------|
| <b>TRAINING PLANNING</b> | REGISTER:GP6RE02 |
|                          | DATE: 11/13      |
|                          | VERSION: 1       |
|                          | MODIFICATION:    |

| TRAINING PLANNING |            |          |      |          |
|-------------------|------------|----------|------|----------|
| NEEDS             | PETITIONER | AIMED AT | DATE | COMMENTS |
|                   |            |          |      |          |
|                   |            |          |      |          |
|                   |            |          |      |          |
|                   |            |          |      |          |
|                   |            |          |      |          |
|                   |            |          |      |          |
|                   |            |          |      |          |
|                   |            |          |      |          |

### C.1.6 GP6RE03. Training Assessment

|                            |                  |
|----------------------------|------------------|
| <b>TRAINING ASSESSMENT</b> | REGISTER:GP6RE03 |
|                            | DATE: 11/13      |
|                            | VERSION: 1       |
|                            | MODIFICATION:    |

|  |  |  |  |
|--|--|--|--|
| <b>COURSE</b>                            |  | <b>COURSE CODE</b>                       |  |
| <b>NEEDS :</b>                           |  |  |  |
|  |  |  |  |
| <b>CONTENT :</b>                         |  |  |  |
|  |  |  |  |
| <b>EXTERNAL</b> <input type="checkbox"/> |  | <b>INTERNAL</b> <input type="checkbox"/> |  |
| <b>TRAINING COMPANY</b>                  |  |  |  |
| <b>PLACE</b>                             |  |  |  |
| <b>DATE</b>                              |  |  |  |
| <b>HOURS</b>                             |  |  |  |
| <b>ATTENDANTS</b>                        |  |  |  |
|  |  |  |  |
|  |  |  |  |
|  |  |  |  |

|  |                               |                                  |                                    |
|--|-------------------------------|----------------------------------|------------------------------------|
| <b>ATTENDANTS COURSE ASSESSMENT</b>  |                               |                                  |                                    |
| VERY GOOD <input type="checkbox"/>   | GOOD <input type="checkbox"/> | REGULAR <input type="checkbox"/> | DEFICIENT <input type="checkbox"/> |
| <b>TECHNOLOGY MANAGER ASSESSMENT</b>   |                               |                                  |                                    |
| <b>HAS THE COURSE BEEN EFFECTIVE? YES <input type="checkbox"/> NO <input type="checkbox"/></b> |                               |                                  |                                    |
| <b>TECHNOLOGY MANAGER SIGNATURE</b>  |                               |                                  |                                    |
|  |                               |                                  |                                    |



### C.1.7 GP7RE01. Complaints and Suggestions List

|                                 |                  |
|---------------------------------|------------------|
| COMPLAINTS AND SUGGESTIONS LIST | REGISTER:GP7RE01 |
|                                 | DATE: 11/13      |
|                                 | VERSION: 1       |
|                                 | MODIFICATION:    |

|                                   |  |
|-----------------------------------|--|
| COMPLAINT CODE:                   |  |
| DATE                              |  |
| CUSTOMER                          |  |
| TECHNICIAN                        |  |
| COMPLAINT- SUGGESTION DESCRIPTION |  |
| SOLUTION GIVEN / ACTION TAKEN     |  |
|                                   |  |
| COMMENTS                          |  |
|                                   |  |
| PROBLEM/CAUSE                     |  |
|                                   |  |
| CORRECTIVE ACTION                 |  |
|                                   |  |

### C.1.8 GP8RE01. Report of Non-Conformity, Corrective Action and Preventive Action

|   |                  |
|---|------------------|
| REPORT OF NON CONFORMITY, CORRECTIVE ACTION AND PREVENTIVE ACTION | REGISTER:GP8RE01 |
|   | DATE: 11/13      |
|   | VERSION: 1       |
|   | MODIFICATION:    |

|       |      |
|-------|------|
| CODE: | DATE |
|       |      |

|   |                     |               |              |
|---|---------------------|---------------|--------------|
| ANNEXES: <input type="checkbox"/> YES <input type="checkbox"/> NO                             | PERSON WHO DETECTS: |               |              |
| NON CONFORMITY DESCRIPTION <input type="checkbox"/> REAL / <input type="checkbox"/> POTENTIAL |                     |               |              |
|   |                     |               |              |
| INMEDIATE ACTION  |                     |               |              |
|   |                     |               |              |
| Responsible immediate action:   |                     |               |              |
| CAUSE   |                     |               |              |
|   |                     |               |              |
| <input type="checkbox"/> CORRECTIVE ACTION / <input type="checkbox"/> PREVENTIVE ACTION       |                     |               |              |
| ACTION  | RESPONSIBLE         | EXPECTED DATE | CLOSURE DATE |
|   |                     |               |              |
|   |                     |               |              |
|   |                     |               |              |
| MONITORING  |                     |               |              |
| Has the action been effective?  |                     |               |              |
| Remarks:  |                     |               |              |
|   |                     |               |              |
| Closing date and signature  |                     |               |              |

## C.1.9 GP10RE01. Questionnaire prior to Initial Validation of Suppliers

|   |                    |
|---|--------------------|
| QUESTIONNAIRE PREVIOUS TO INITIAL VALIDATION OF SUPPLIERS | REGISTER: GP10RE01 |
|   | DATE: 04/14        |
|   | VERSION: 1         |
|   | MODIFICATION:      |

|   |
|---|
| <b>SUPPLIER DATA</b>                                |
| Company name  |
| Telephone   |
| Director  |
| Sales director                                      |
| Product commercialised                              |
| PRODUCTS (brief definition)                         |
|   |
|   |
|   |
| <b>ORGANISATION</b>                                 |
| Does your company have a quality system? Which one? |
| Is your quality system certified?                   |
| To be defined for each company...                   |

## C.1.10 GP10RE02. Supplier Assessment

|                     |                    |
|---------------------|--------------------|
| SUPPLIER ASSESSMENT | REGISTER: GP10RE02 |
|                     | DATE: 04/14        |
|                     | VERSION: 1         |
|                     | MODIFICATION:      |

|                                |
|--------------------------------|
| <b>SUPPLIER:</b>               |
| <b>PRODUCT /SERVICE GIVEN:</b> |
| <b>PERIOD:</b>                 |

| Assessment                               | 2 points | 1 point   | 0 points |
|--|----------|-----------|----------|
| ISO 9100- ISO 13485 certificated?        |          | Yes       | No       |
| Quality of the product expected?         | Yes      | Sometimes | No       |
| Identification and product traceability? | Good     | Regular   | Bad      |
| Delivery dates?                          | Good     | Regular   | Bad      |
| Problem solving                          | Good     | Regular   | Bad      |
| Quality/price                            | Good     | Regular   | Bad      |
|  |          |           |          |

| SUPPLIERS QUALIFICATION |          |                    |
|-------------------------|----------|--------------------|
| PUNTUATION              | CATEGORY | TYPE OF SUPPLIER   |
| X ≥ 10                  | A        | Preferred Supplier |
| 10 < X ≥ 6              | B        | Satisfactory       |
| X < 6                   | C        | Unsatisfactory     |

### C.1.11 GP10RE03. List of Accepted Suppliers

|                            |                    |
|----------------------------|--------------------|
| LIST OF ACCEPTED SUPPLIERS | REGISTER: GP10RE03 |
|                            | DATE: 04/14        |
|                            | VERSION: 1         |
|                            | MODIFICATION:      |

| SUPPLIER NAME | PRODUCTS /SERVICES | CONTACT PERSON | COMMENTS |
|---------------|--------------------|----------------|----------|
|               |                    |                |          |
|               |                    |                |          |
|               |                    |                |          |
|               |                    |                |          |
|               |                    |                |          |

### C.1.12 GP10RE04. Register of Supplier Incidents

|                                       |                   |
|---------------------------------------|-------------------|
| <b>REGISTER OF SUPPLIER INCIDENTS</b> | REGISTER:GP10RE04 |
|                                       | DATE: 04/14       |
|                                       | VERSION: 1        |
|                                       | MODIFICATION:     |

| Supplier | Data | Detected by | Descriptions | Actions | Responsible | Comments |
|----------|------|-------------|--------------|---------|-------------|----------|
|          |      |             |              |         |             |          |
|          |      |             |              |         |             |          |
|          |      |             |              |         |             |          |

### C.1.13 GP10RE05. Continued Assessment of Suppliers

|  |                   |
|--|-------------------|
| <b>CONTINUED ASSESSMENT OF SUPPLIERS</b> | REGISTER:GP10RE05 |
|  | DATE: 04/14       |
|  | VERSION: 1        |
|  | MODIFICATION:     |

|  |
|--|
| <b>SUPPLIER:</b>   |
| <b>PRODUCT /SERVICE GIVEN:</b>   |
| <b>DATA OF REASSESSMENT:</b>   |
| <b>PUNTUATION BEFORE THE REASSESSMENT</b>  |
| <b>PUNTUATION AFTER THE REASSESSMENT</b>   |
| <b>IS THERE ANY MODIFICATION OF TYPE OF SUPPLIER? YES <input type="checkbox"/> NO <input type="checkbox"/></b> |
| <b>ACTIONS TO BE TAKEN</b>   |
| <b>RESPONSIBLE</b>   |
| <b>COMMENTS</b>  |

## C.2 Operational Instructions

### C.2.1 OI11RE01. Powder Container Register

|                           |                  |
|---------------------------|------------------|
| POWDER CONTAINER REGISTER | REGISTER:GP5RE01 |
|                           | DATE: 11/13      |
|                           | VERSION: 1       |
|                           | MODIFICATION:    |

|                           |      |
|---------------------------|------|
| CONTAINER CODE:           |      |
| TYPE OF POWDER            | Ti64 |
| POWDER BATCH N°           | P865 |
| CHEMICAL ANALYSIS RESULTS |      |
|                           | Ti   |
|                           | Al   |
|                           | V    |
|                           | C    |
|                           | N    |
|                           | O    |
|                           | ...  |

### C.2.2 OI11RE02. Build Register Key Features

|                               |         |
|-------------------------------|---------|
| BUILD FILE CODE:              |         |
| BUILD MATERIAL                | Ti64    |
| BUILD HEIGHT (MAGICS)         | 45.60   |
| LAYER THICKNESS (EBM BUILDER) | 0.05    |
| BUILD PLATE SIZE              | 150x150 |
|                               |         |
|                               |         |

## C.3 Control Procedures for EBM/SLM

### C.3.1 CP1RE01. Powder Chemical Analysis

#### Certificate of Analysis

**Customer**

AIMME - Instituto Tecnológico  
Metalmecánico  
Parque Tecnológico  
Avda. Leonardo Da Vinci, 38

Paterna, 46980  
Spain

**Supplier**

Arcam AB  
Krokslatts Fabriker 27A  
SE-431 37 Möndal  
Sweden

**Material**

Arcam Ti6Al4V Powder

**Batch Number**

P828

**Customer PO Number**

No SOL13-0560

**Quantity**

60 kg

**Chemical Analysis**

| Element        | Al       | V       | C     | Fe    | O    | N     | H      | Ti  |
|----------------|----------|---------|-------|-------|------|-------|--------|-----|
| ISO<br>5832-3* | 5,5-6,75 | 3,5-4,5 | <0,08 | <0,30 | <0,2 | <0,05 | <0,015 | Rem |
| %              | 6,1      | 4,1     | 0,02  | 0,19  | 0,14 | 0,01  | 0,003  | bas |

\* Note – This standard applies to the chemistry of the powder only

Möndal, Sweden

2013-07-29

Ante Kristic / +46 031 710 32 21



### C.3.2 CP3RE01. Control of the Part Cleaning and Sandblasting Checklist

|                                  |    |       |
|----------------------------------|----|-------|
| Build plate reference            |    |       |
| Operator machine                 |    |       |
| Parameters to control            |    |       |
| Powder removal control           | OK | NO OK |
| Visual control of the final part | OK | NO OK |
| Roughly dimensions control       | OK | NO OK |
| Comments                         |    |       |

### C.3.3 CP4ARE01. Recycled Powder Chemical Analysis

| Date       | Build project | Chemical analysis [O] | Materials consultant signature | Comments              |
|------------|---------------|-----------------------|--------------------------------|-----------------------|
| 01/02/2013 | BP_EBM_2134   | 0.14                  | <input type="checkbox"/> ok    | Aerospace application |
|            |               |                       | <input type="checkbox"/> ok    |                       |
|            |               |                       | <input type="checkbox"/> ok    |                       |
|            |               |                       | <input type="checkbox"/> ok    |                       |
|            |               |                       | <input type="checkbox"/> ok    |                       |
|            |               |                       | <input type="checkbox"/> ok    |                       |

### C.3.4 CP4BRE01. Quality Control of the Final Part

|                                  |    |       |
|----------------------------------|----|-------|
| Data                             |    |       |
| Build plate reference            |    |       |
| Operator machine                 |    |       |
| Parameters to control            |    |       |
| Powder removal control           | OK | NO OK |
| Visual control of the final part | OK | NO OK |
| Roughly dimensions control       | OK | NO OK |
| Comments                         |    |       |

# Appendix D Examples of Build Report and Log Data

## D.1.1 EBM Build Report

### EBM Control Build Report

#### Build Summary

---

|                        |                                 |
|------------------------|---------------------------------|
| Serial Number          | R1054_2013-09-26_8.56           |
| Powder Batch           | P828                            |
| Build Name             | CIMA_ultima fabricaciÃ³n        |
| Last Processed Z-Level | 257.300 mm                      |
| Selected Start Z-Level | 0.050 mm                        |
| Selected End Z-Level   | 257.300 mm                      |
| Build Start Time       | 9/26/2013 10:40 AM              |
| Build Stop Time        | 9/28/2013 12:09 PM              |
| Build Time of Parts    | 49.5 Hours                      |
| Material Theme         | Ti6Al4V                         |
| Build Envelope         | \\BuildEnvelope\A2\Arcam\A2HIGH |
| Layer Thickness        | 0.05                            |
| Machine Name           | R1054                           |
| Software Version       | 3.2.132.14429                   |

#### Validation Result

---

|                   |                                     |       |
|-------------------|-------------------------------------|-------|
| Build Completed   | <input checked="" type="checkbox"/> | _____ |
| Validation Result | <input type="checkbox"/>            | _____ |

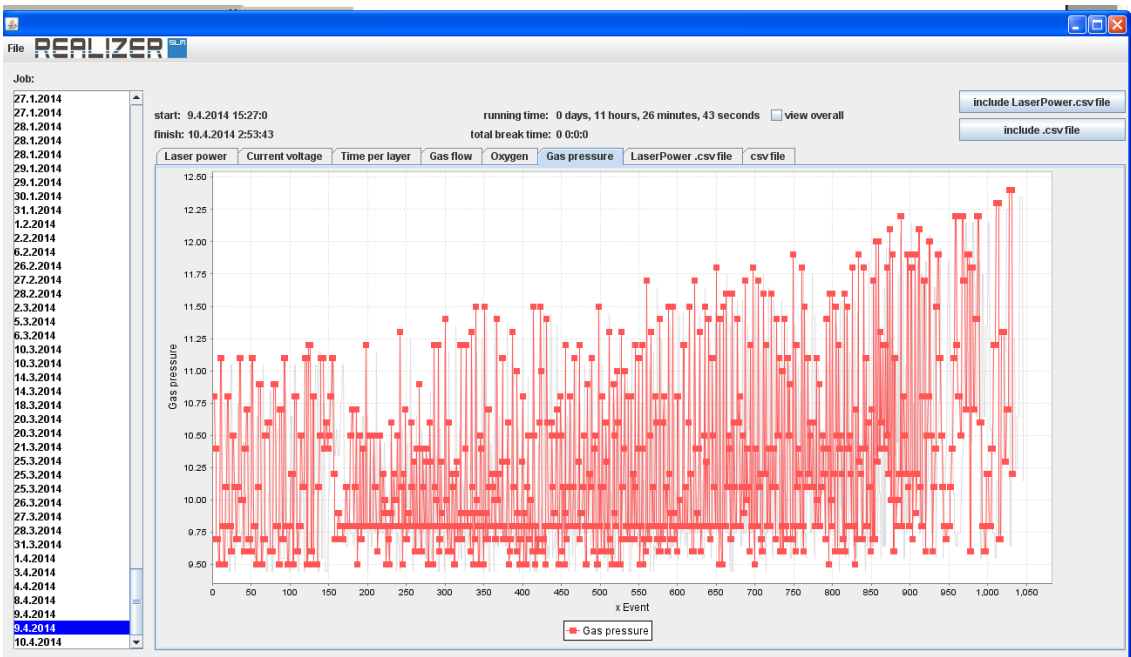
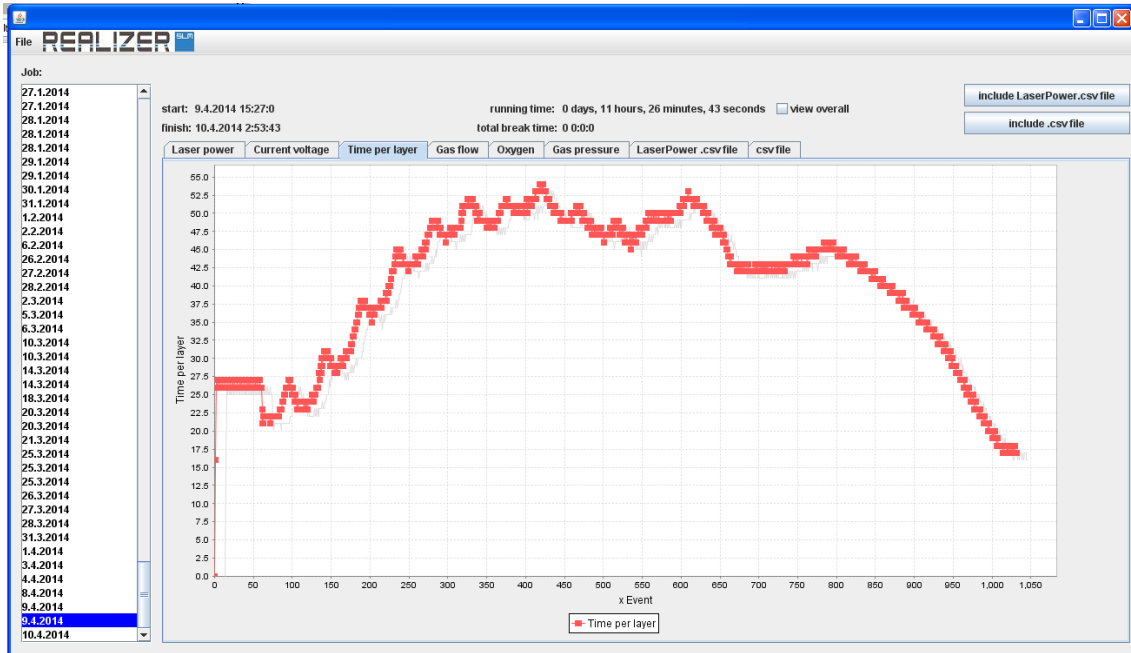
#### Unsuccessful Validation Rules

---

|   |             |                |       |
|---|-------------|----------------|-------|
| Allowed Beam Current Range During Melting | 0.0 - 15.8  | 0.5 - 20.0 mA  | _____ |
| Allowed Scan Speed Range In Squares       | -1 - 1555.7 | 40 - 4000 mm/s | _____ |
| Max Chamber Pressure CV-EBM               | 4.9E-3      | <= 4E-3 mBar   | _____ |
| Min Layer Thickness                       | 0           | >= 0.05 mm     | _____ |



## D.1.2 SLM Build Log



## Appendix E EBM/SLM Relevant Variables

This section describes and analyses all EBM/SLM critical variables. Furthermore, all standard parameters for EBM and SLM to be stored in a database to ensure the repetitiveness of the AM processes are defined.

It is crucial to ensure the traceability of the process parameters that have been used to build a part. For this reason, all process parameters involved in the build of every part have to be registered.

In order to ensure the quality assurance process, all the processed parameters of the technology are fixed. Depending on the material, parameters are different, so the parameters will be the standard parameters of the technology provider for each material.

### E.1.1 EBM process parameters description

#### Preheating parameters

- **Focus offset.** *Used for offsetting calibrated focus value.*
- **Activate heater.** *The preheated area will be stored and can be used for heating in subsequent process steps. The same area will be used for decreasing or increasing current between process steps.*

Beam speed and hatch will be the same as used for preheating the square. Beam current will be equal to maximum calculated current. If there is no heater activated there will be a warning since the current slew rate function will not work in this case.

- **Use energy consumption.** *An energy buffer will be used for maintaining the overall energy consumption for all process steps.*

When enabled the total energy for each process step is compared to the desired energy, which is obtained from either the mean current for the preheat step or from the calculated current in the melt step. The energy difference is added to an energy buffer and used in the heating step. For each new layer the energy buffer is cleared.

When the energy buffer is enabled the total energy from all the activated process steps are considered and accounted for. If it is disabled each process step considered to be a single energy event.

For a single process step the amount of energy added or extracted from the energy buffer is calculated as follows:

$$t_h = \frac{E_s - P_r \cdot t_s - E_b}{P_r - P_h}$$

where,

$t_h$ :Time for heating

$E_s$ :Energy in process step

$P_r$ :Required Power

$t_s$ :Time in process step

$E_b$ :Energy in buffer

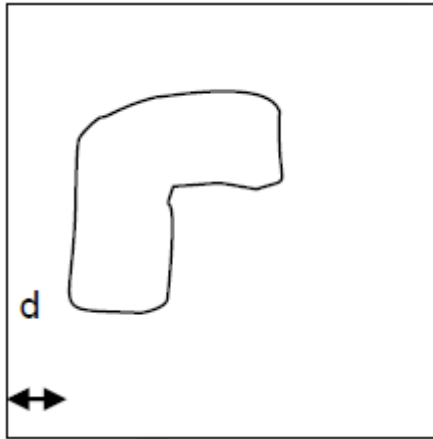
$P_h$ :Power in heating

### **Square**

A square will be used to encompass all models in the build.

- **Size.** *Size of the square. When auto calculation is true this will be the reference size used for calculating beam settings as well as the minimum size allowed.*
- **Offset to part.** *The minimum distance between the models and the periphery of the preheated area.*

The position of the square relative to the model is obtained by minimizing the distance between the centre of the present squared and the centre of the previous square. In this way squares for different layers are more or less forced to be on top of each other and pulled towards the centre of the build envelope.



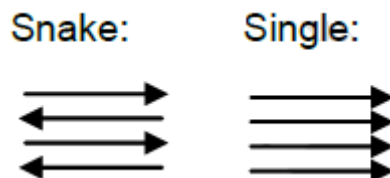
**Figure D-0-1** Offset to part

- **Auto calculation.** For arbitrary square sizes beam settings will be calculated automatically.
- **Max current.** The maximum current that will be used for this module. (mA)

### Hatch

Hatch properties within the square. It is also called “strategy”.

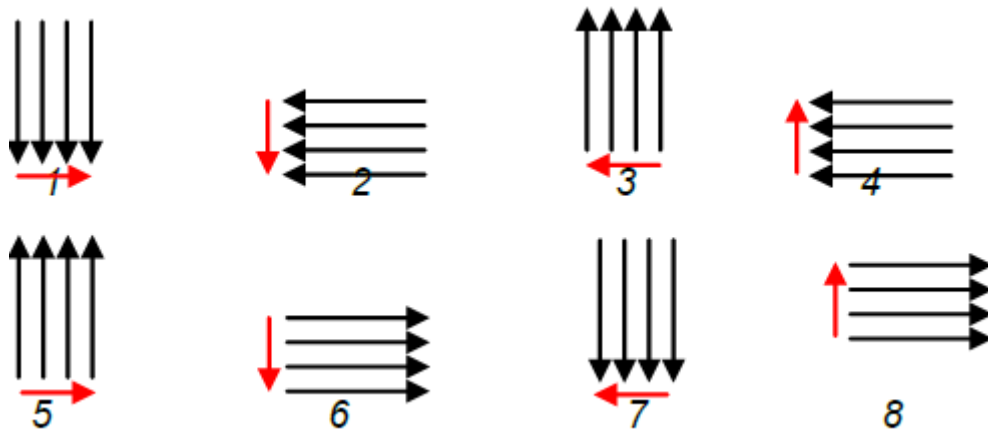
- **Snake.** Determine if hatching should be performed back and forth



**Figure D-0-2** Hatch strategies

- **Line order.** Determines in which order hatch lines will be melted or heated.
- **Line offset.** Offset between two hatch lines.
- **Randomised Hatch.** Randomise hatch direction.

If single hatch is used there will be eight different hatches as depicted below. For each new hatch depth one of them will be picked by random. Black arrows indicate beam scan direction whereas red arrows indicate hatch direction.



**Figure D-0-3** Randomise hatch

- **Hatch depth.** *The same hatch depth was used before changing to the next layer.*
- **Direction.** *Controls the direction of the hatch that will be the used as the starting hatch.*

### **Beam**

Beam properties for a complete set of hatch lines.

- **Max beam current.** *If auto calculation is enabled it will be the max current for the reference square.*
- **Min beam current.** *If auto calculation is enabled it will be the min current for the reference square.*
- **Beam speed.** *If auto calculation is enabled it will be the speed for the reference square.*
- **Number of repetitions.** *The number of repetitions for ramping up the current from min current to max current. If auto calculation is enabled it will be the number for the reference square.*
- **Maximum number of repetitions.** *The maximum number of repetitions allowed when auto calculation is enabled.*

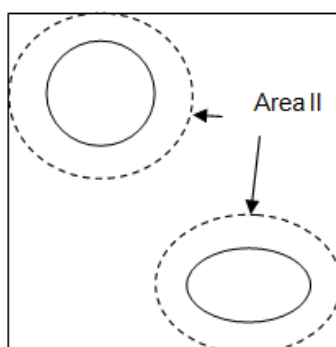
If the calculated number of repetitions becomes equal to this number a warning will be issued saying that the pre heated area may be too large.

- **Number of repetitions at max current.** *The number of repetitions at max current that will be added after ramping. Not used when auto calculation is enabled.*
- **Mean current.** *The desired mean current for this process step.*  
The mean current will be used for determining the amount of energy that should be used when heating subsequent process steps.  
Increasing or decreasing this value will affect the heating for all process steps.
- **Heat loss factor.** *Used when calculating the required energy in automatic mode.*  
The heat loss factor describes the loss of heat through the surface down in to the material. It will be possible to differentiate the energy loss between hard and loos sintered powder.

## PREHEATING II PARAMETERS

The intention of this step is to preheat the powder circumventing the parts with an additional preheat sequence. If preheat I is disabled the entire square will be preheated.

- **Mean current.** *The desired mean current for this process step.*  
The total mean current will be used for determining the amount of energy that should be used when heating subsequent process steps. See Figure D-0-4.



Square area = Preheating I = Area I  
Circular dashed lines = Preheating II = Area II  
Circular solid line = melt area

When both preheating I and II are activated the calculated mean current of the preheating step will be:

$$MeanCurr = \frac{MeanCurrI(AreaI - AreaII) + MeanCurrII \cdot AreaII}{Area\_Ref}$$

**Figure D-0-4** Mean current

## HEATING

Heating will occur after the process step. The heating area is the same as in the preheating step.

- **Maximum heat time.** *This is the maximum heat time for this process step.*
- **Heating factor.** *A factor that controls the amount of heating for the process step. e.g. Increase this value if there is need for more heating in a specific process step.*

### **MELT PARAMETERS**

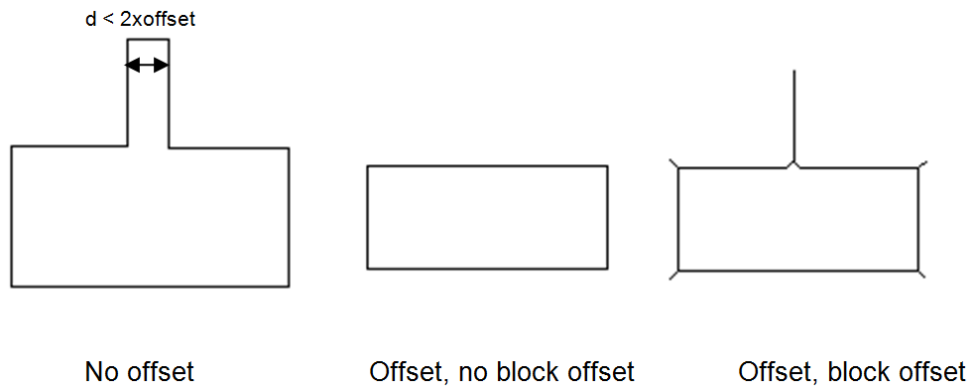
- **Melt.** *Module for melting*
- **Power analyse.** *Module for controlling the power calculation.*
  - **Automatic power calculation.** *Used for calculating melt current and melt speed automatically.*
  - **Surface temp.** *The desired surface temperature. Used for controlling the automatic calculation.*

The surface temperature controls the amount of power that will be used for melting. All models loaded for the process step are included in the calculation. The goal of the calculation is to maintain a constant surface temperature during the build by adapting the power with regard to the geometries of the models.

### **CONTOURS PARAMETERS**

- **Number of Contours**
- **Block Offset.** *When enabled this function prevents contours for features thinner than 2xoffset from disappearing.*

The periphery contour after using no offset, offset and offset together with the block offset function.



**Figure D-0-5** Offset

## **OUTER**

The periphery contour closest to the powder.

- **Offset.** *Contour off-set. Off-set is used to account for the size of the melt pool.*
- **Beam.** *Beam properties.*
- **Speed.** *The beam speed when melting in manual mode.*
- **Current.** *The beam current when melting in manual mode.*
- **Max current.** *The maximum beam current that will be used for this function.*
- **Focus offset.** *Used for offsetting calibrated focus value.*
- **Speed function.** *The index for the speed function that controls the speed when melting in automatic mode. A higher value gives higher speed.*

For specific values of current and index the speed is obtained by interpolation in a look up table.

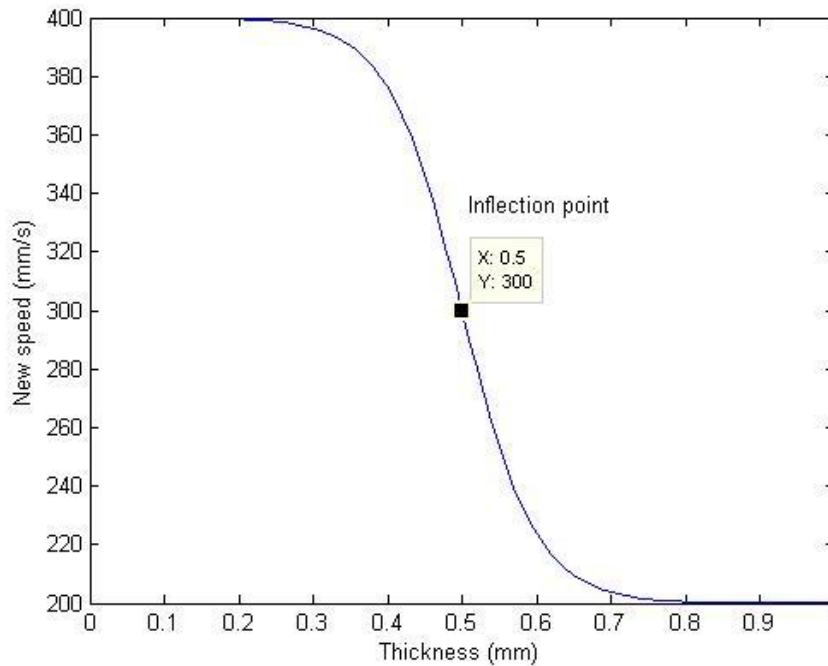
## **THICKNESS Z**

A thickness function that controls the speed in areas where the z-distance from the surface down to powder is short.

In Figure D-0-6 the appearance of the thickness function (new speed) is depicted as a function of the z-thickness. The speed has been put to 200 mm/s.

$$NewSpeed = \left(1 + \frac{SpeedFactor}{e^{(ExpFactor \cdot (Thickness - ThickFactor))} + 1}\right) \cdot speed$$





**Figure D-0-6** Thickness function

- **Max thickness.** *The maximum thickness that will be considered. (mm)*
- **Speed factor.** *A pre-exponential scale factor used for calculating how much the speed will affect the thickness function.*  
The maximum speed contribution at thickness zero.
- **Thickness factor.** *An exponential factor used for calculating how deep the depth contribution will affect the thickness function.*  
This parameter controls the position of the inflection point.
- **Exponent factor.** *An exponential factor used for calculating how fast the depth contribution will decay.*  
This parameter controls the slope of the curve at the inflection point.

## **INNER**

All contours on the inside of the outer contour. These settings will be used if the number of contours is greater than 1.

If the number of contours is greater than 1 all contours on the inside of the outer contour will have the inner contour settings.

- **Contour overlap.** *An overlap at the end of the contour.*

By overlapping the contour the starting point will be melted twice. The amount of overlap is increased linearly with the length of the contour from minimum overlap up to maximum overlap.

- **Minimum overlap.** *Minimum contour overlap.*
- **Maximum overlap.** *Maximum contour overlap.*
- **Maximum contour length.** *When the contour is greater than this length, maximum overlap will be used.*
- **Max revolutions.** *Maximum number of revolutions*

If contour is very short, max revolutions may override minimum overlap.

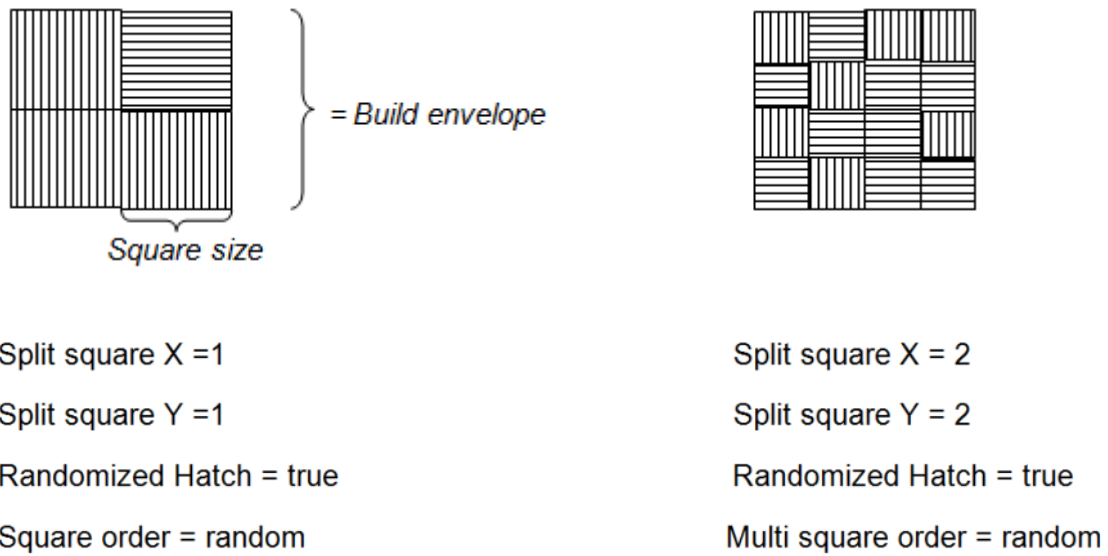
$$\text{Overlap} = \min \{ \text{MaxRev} \cdot \text{ContLength}, \text{MinOverlap} \}$$

## SQUARES

The interior area without contours will be divided in to squares.

The total number of squares and their size will be determined by the size of the square.

- **Offset to contour.** *The offset between the contour area and the interior area.*  
This is the distance between the innermost contour and the area on the part that will melt as squares.
- **Square.** *Properties of each square.*
- **Size.** *Size of each square.*
- **Split square X.** *The number of multi squares each square will be divided to into the x direction.*
- **Split square Y.** *The number of multi squares each square will be divided to into the y direction.*
- **Turning points.** *A turning point function that will prevent over heating by controlling the speed in areas where the beam will make a 180 deg turn.*



**Figure D-0-7** Squares

- **Min points / change.** *Speed changes are made in steps. This is the minimum number of sampling points allowed in one step.*
- **Pre exponential factor.** *A pre-exponential factor that will affect the overall appearance of the speed contribution for the turning point function.*
- **Exp factor I.** *Exponential factor that affects the extension of the turning point region.*
- **Exp factor II.** *Exponential factor that mostly affects the amplitude distribution for the speed contribution within the turning point region.*
- **Net.** *Function for controlling the position of the squares and the hatch with respect to layer height.*
- **Increase square X positions / mm height.** *For one mm height the total square X positions will be moved this amount.*
- **Increase square Y positions / mm height.** *For one mm height the total square Y positions will be moved this amount.*
- **Hatch line offset / mm height.** *An offset for preventing the hatch line from being stacked on top of each other within the squares. For one mm height the hatch lines will be moved this amount.*
- **Order.** *Order in which squares are melted.*

- **Square order.** *The order in which the non-divided squares will be handled.*
- **Multi square order.** *The order in which the smaller divided squares will be handled.*

There are three possibilities: order, snake, random.

$$newspeed = speed \cdot (1 + speedinc)$$

$$speedinc = SpeedFact \cdot e^{-(speed \cdot (ExpFactI \cdot dist - ExpFactII \cdot speed))^2}$$

The variable “dist” is equal to the distance between the end point of line “i” and the beam position on line “i+1”.

## E.1.2 SLM process parameters description

### Preheating

The platform heater is activated to heat the baseplate and the side walls of the piston chamber.

### Laser Parameters

The hatch spacing is the parameter that determines the distance between the laser scan lines. This hatch distance is important in defining the amount of weld overlap, which determines material density. The point distance is defined as the distance the laser moves over in a set period of time. This time is represented by the exposure time. Both the point distance and exposure time can be combined to form the laser scanning velocity. Varying all these parameters will affect how the melt pool is formed and therefore affects the material density and the surface finish.

- **Point Distance.** *Point distance is defined as the distance the laser moves over in a set period of time.*
- **Exposure Time.** *Exposure time is defined as the time the laser takes to move over the point distance.*
- **Laser Power.** *The amount of mA defined in the material file determines the power that is delivered to melt the powdered material. Note: For Realizer SLM 100 equipped with 200W laser 200mA delivers 10W of laser power.*

- **Frequency.** *The laser can be operated at different frequencies; the default setting is 0 Hz.*
- **Focus.** *The focal point of the laser can be moved by manipulating the optical lens. This has the effect of creating a larger spot size that has a flatter Gaussian beam profile.*
- **Layer Thickness.** *The layer thickness can be varied; this determines how much material is melted per slice.*

### **Boundary, Contour, Support and Hatch Strategies**

Each of the following parameters each has set of laser parameters assigned to them.

- **Inner Support.** *If the supports have thickness, then the inner support parameter determines the parameters used for the internal features seen in a 2D slice.*
- **Outer Support.** *If the supports have thickness, then the outer support parameter determines the parameters used for the internal features seen in a 2D slice.*
- **X Support.** *This determines the parameters used if only single line supports are used in the x direction.*
- **Y Support.** *This determines the parameters used if only single line supports are used in the y direction.*
- **Inner Boundary.** *This strategy sets the laser parameters used for the internal features of the part to be manufactured when seen in a 2D slice.*
- **Outer Boundary.** *This strategy sets the laser parameters used for the external features of the part to be manufactured when seen in a 2D slice.*
- **X Hatch.** *This strategy sets the laser parameters used for the x direction hatch of the part to be manufactured.*
- **Y Hatch.** *This strategy sets the laser parameters used for the y direction hatch of the part to be manufactured.*
- **Fill Hatch.** *This strategy sets the laser parameters used for the internal and external features of the part to be manufactured. The fill hatch is a placed in-between the boundaries and the hatch.*

- **Repetition.** *This determines the number of repetitions the above scan strategies have per slice layer.*

### **Hatch Group Global Parameters**

- **Min Hatch Length.** *This determines the minimum dimension that will be hatched.*
- **Hatch Stripe RightLeft.** *This determines the order in which the scanning will take place.*
- **Hatch Stripe UpDown.** *This determines the order in which the scanning will take place.*
- **Hatch Sort Block Size.** *This parameter defines how the scan strategy is optimised.*
- **Use Hatch Definition.** *This can be used to vary the hatch parameters at different layer heights. Choices are: disabled, every even layer, every odd layer.*

### **Hatch Group Standard Parameters**

- **Sort Type.** *This scan parameter determines how the scan strategy is ordered. The choices are: no sort, sort rose, sort optimal with approx., best sort, sort with chequered pattern.*
- **Type.** *This parameter has input into determining the scan strategy used. There can either be no hatch scanned, alternated layers of x then y hatch scanning, and then both x and y hatches being scanned on the same layer.*
- **Offset.** *This parameter determines the distance between the hatch and the boundary scan.*
- **X Distance.** *This distance represents the distance between scan lines for the x hatch.*
- **Y Distance.** *This distance represents the distance between scan lines for the y hatch.*
- **With Strips.** *This option allows the scan to be separated into stripes.*

- **Stripe size.** *This parameter determines the size of the stripes to be used for the x and y hatch.*
- **Contour offset.** *This determines the distance between each contour scan line.*
- **Contour Fill Count.** *This parameter determines how many contours will be scanned.*