

3 8006 10057 9963



REPORT NO. 51

January, 1952

THE COLLEGE OF AERONAUTICS

C R A N F I E L D

Stress Distribution near a Rectangular Cut-out
in a Reinforced Circular Cylinder due to Direct
Shear Loading and Torque

Part I: Test Results

- by -

G.S. Henson, D.C.Ae.

--ooOoo--

S U M M A R Y

A cylindrical reinforced cylinder 187" by 100.6 outside diameter, with two horizontally opposed rectangular cut-outs was loaded separately by direct shear and torque.

Electric resistance strain gauges indicated skin shear in the bay with cut-outs, longeron and frame loads, and stringer-longeron web shear.

The stress distributions found are compared with those of previous tests with this structure, when fitted with transverse (floor) beams and a third (luggage hatch) cut-out.

The present tests are compared with theoretical predictions in Reference 1. Fair agreement is obtained.

- - - - -

C O N T E N T S

Introduction

	<u>Page</u>
1. Introduction	1
2. Apparatus	1
3. Details of Tests	1
4. Results	2
5. Conclusions	2
References	4

Appendix: Criticism of Cut-out Design 6

Table I 7

Figures

Details of Tests

Load was applied in increments and percentage change of resistance noted. These were plotted and show very good linearity. Typical plots are shown in Figures 4 and 5. It will be seen that for direct shear loading, each pressure was plotted directly along pressure-load calibration followed a straight line law. In some cases a change of slope occurred with skin buckling. Sides of these plots were recorded giving percentage resistance change due to load increments of direct shear (AW) or torque (AT).

1. Introduction

The specimen available for tests had been modified to contain cut-outs and tested to destruction by the Bristol Aeroplane Co. Ltd. (Reference 2).

It was repaired and simplified by removing floor beams and filling a third cut-out, to leave the structure given in Table I and Figures 2, 3, 6 and 7. This comparatively simple structure was expected to be more amenable to calculation, and by comparison with previous tests, to indicate floor beam effects.

Study of previous work (see references) showed that there existed a need for such investigation, particularly on a structure that could be considered typical of present (pressurised) aircraft, in having a heavy angle member at the edge of the cut-out, connecting reinforced frames and longerons.

2. Apparatus

A simple 'A Frame' was strengthened, and a calibrated hydraulic torque and direct shear loading rig added. Ram bending and friction effects were reduced as far as possible. The specimen was locally strengthened and bolted to a rigid backplate of steel I beams, Figure 1. 90 ohm strain gauges (H. Tinsley and Co. Ltd.) were cemented to the specimen in shear and tension groups. Compensation for temperature changes was provided, and, where both sides of the material were accessible, also for buckling. In the few cases where buckling compensation was required but could not be provided, results have been neglected.

Percentage resistance change of these gauges was measured on a 50 way R.A.E. type, Savage and Parsons unit.

Deflections of the specimen were measured relative to the floor, and the deflections of the backplate were taken at three points to enable tilt to be measured and to ensure negligible rig distortion and consistency between tests.

3. Details of Tests

Load was applied in increments and percentage change of resistance noted. These were plotted and show very good linearity. Typical plots are Figures 4 and 5. It will be seen that for direct shear loading, jack pressure was plotted directly since pressure-load calibration followed a straight line law. In some cases a change of slope occurred with skin buckling. Slopes of these plots were recorded giving percentage resistance change due to load increments of direct shear (ΔW) or torque (ΔT).

Skin shear distribution about the centre line of bay with cut-outs was first determined - Figures 9 and 10. Assuming values of shear modulus, skin thickness (nominally 19G) and gauge sensitivity factor this was converted to values of resistance of skin to load.

Since resistance to ΔW was 87 per cent while resistance to ΔT was 98 per cent of applied load, further tests included investigation of stringer and longeron web loads in one quadrant of the cylinder, Figure 8. In fact, 5 per cent of the resistance to ΔW proved to come from stringer and longeron webs in shear (of course, these could not resist ΔT). Frame and longeron axial strains were also found.

4. Results

Assuming values for the elastic constants of the materials, and the gauge sensitivity factor, and calculating section constants for the various members (making allowance for skin tension and compression cases), the readings of strain were converted to skin stresses, web loads and frame and longeron loads. These results have been presented graphically.

After checking results for linearity of strain across the section of a member, Figure 6, load increments in a member by more than one method etc. (figures 8, 12 and 13), it is felt that these results give fair indication of the stress distribution at the corner of the cut-out investigated.

The most doubtful value plotted is that of maximum frame load where some non-linearity of strain across the section was found. The value plotted is thought to be within 10 per cent of the true value.

Also of doubtful value is the distribution of direct stress near the cut-out (Figure 11). This is due to the poor skin riveting and resultant skin buckling even in unloaded condition. These gauges were compensated for buckling, but rate of acceptance of load was affected.

5. Conclusions

Tests

The filled in cut-out did not affect the symmetry of stress distribution. Removal of floor beams had little effect on skin shear stress but completely changed the pattern of frame loads.

1. Skin Shear

When direct shear ΔW was applied, the maximum shear stress found was 2.6 times that for uncut cylinder, and occurred in the bay with cut-outs, the stress in other bays being very considerably below this (Reference 2). Skin provided 87 per cent of the

resistance to this load, and stringer and longeron webs 5 per cent: total 92 per cent. For torque ΔT applied, the maximum stress was 3.4 times that for uncut cylinder, the skin providing 98 per cent of resistance.

Since results are based on over 700 strain gauge readings, and only the calibrated loading apparatus differed between tests, better agreement had been expected between these resistances.

2. Longeron Loads

Stress due to axial load was small (20 per cent of the stress due to BM). Both BM and axial load were a maximum at the edge of the cut-out and died away exponentially. BM was of the same magnitude as that in the frame.

3. Frame Loads

Both BM and axial load were a maximum at the edge of the cut-out and thereafter very rapidly became negligible.

4. Skin Hoop Stress reached a high value (Figure 11).

5. Skin Buckling

The load-strain curve became almost linear again after skin buckling, but a given load increment then caused about 18 per cent more stress at some points in frame, and longeron near the cut-out, than before buckling. Maximum skin shear stress increased similarly about 8 per cent.

Theory

Theoretical prediction of the stresses is compared with these test results in Reference 1.

Design

The structure may be considerably simplified and maximum stresses decreased by a simple change in layout and a further change in longeron construction (Appendix I).

R E F E R E N C E S

- | <u>No.</u> | <u>Author</u> | <u>Title, etc.</u> |
|------------|---|---|
| 1. | Henson, G.S. | Stress Distribution near a Rectangular Cut-out in a Reinforced Circular Cylinder due to Direct Shear Loading and Torque. Part II, Theory. College of Aeronautics Report (to be published). |
| 2. | Butler, S. | Type 167 Shear Tests on Half Scale Fuselage with Door Cut-outs. Sc. and Tech. Memo. 6/50. |
| 3. | Gololobov, M.M. | Shear Distribution due to Twist in a Cylindrical Fuselage with Cut-out. Jour. Aeronautical Sciences Vol.14, 1947. pp.253-6. |
| 4. | Langhaar, H.L.
and
Smith, C.R. | Stresses in Cylindrical Semi-Monocoque Open Beams. Jour. Aeronautical Sciences Vol.14, 1947. pp.211-20. |
| 5. | Podorozhny, A.A. | Investigation of the Behaviour of Thin-Walled Panels with Cut-outs. NACA Tech. Memo.1094, 1946. |
| 6. | Kay, W. and
Micklethwaite, F. | The Stressing of Large Rectangular Cut-outs in Fuselages. Strain Gauge Analysis of York. A.R.C. R and M. 2135. |
| 7. | Hoff, N.J. and
Boley, B.A. | Stresses in, and General Instability of, Monocoque Cylinders with Cut-outs. I - Experimental Investigation of Cylinders with a Symmetric Cut-out subjected to Pure Bending. NACA Tech. Note 1013, 1946. |
| 8. | Hoff, N.J.,
Boley, B.A. and
Klein, B. | Stresses in, and General Instability of, Monocoque Cylinders with Cut-outs. II - Calculation of the Stresses in a Cylinder with a Symmetric Cut-out. NACA Tech. Note 1014, 1946. |
| 9. | Hoff, N.J.,
Boley, B.A. and
Klein, B. | Stresses in, and General Instability of, Monocoque Cylinders with Cut-outs. III - Calculation of the Buckling Load of Cylinders with Symmetric Cut-out subjected to Pure Bending. NACA Tech. Note 1263, 1947. |

References (contd.)

<u>No.</u>	<u>Author</u>	<u>Title, etc.</u>
10.	Hoff, N.J., Boley, B.A. and Viggiano, L.R.	Stresses in, and General Instability of, Monocoque Cylinders with Cut-outs. IV - Pure Bending Tests of Cylinders with Side Cut-out. NACA Tech. Note 1264, 1947.
11.	Hoff, N.J., and Klein, B.	Stresses in, and General Instability of, Monocoque Cylinders with Cut-outs. V - Calculation of the Stresses in Cylinders with Side Cut-out. NACA Tech. Note 1435, 1948.
12.	Hoff, N.J., Klein, B. and Boley, B.A.	Stresses in, and General Instability of, Monocoque Cylinders with Cut-outs. VI - Calculation of the Buckling Load of Cylinders with Side Cut-out subjected to Pure Bending. NACA Tech. Note 1436, 1948.
13.	Hoff, N.J., Boley, B.A. and Mele, J.J.	Stresses in, and General Instability of, Monocoque Cylinders with Cut-outs. VII - Experimental Investigation of Cylinders having either Long Bottom Cut-outs or Series of Side Cut-outs. NACA Tech. Note 1962, 1949.
14.	Hoff, N.J., Boley, B.A. and Mandel, M.W.	Stresses in, and General Instability of, Monocoque Cylinders with Cut-outs. VIII - Calculation of the Buckling Load of Cylinders with Long Symmetric Cut-out subjected to Pure Bending. NACA Tech. Note 1963, 1949.
15.	Cicala, P.	Effects of Cut-outs in Semi-Monocoque Structures. Jour. Aeronautical Sciences Vol. 15, 1948, pp.171-179.

A P P E N D I X

Criticism of Design

The load carrying ability of the existing structure seems to be open to criticism at two points:

- (i) Since the cut-out edge member and longeron are separated, the edge member transmits large axial loads (in a longitudinal direction) which have to be resisted by the frames at the cut-out in sideways bending.
- (ii) The maximum value of bending (in a normal manner) and axial load in the frames at the cut-out occurs at a point of low second moment of cross sectional area.

Separation of Longeron and Cut-out Edge Member

The discontinuity in skin shear stress distribution occurring at the longeron (Figure 10) indicates an axial load increment in the longeron of the order found (Figure 13).

A discontinuity four times as great occurs at the edge of the cut-out. This implies the presence of axial loads of a high order. There is little re-distribution of stress after buckling. These loads cannot continue as direct stresses and must load the skin and frame at Y (Figure 16a) in an unconventional manner. This is supported by the skin buckling that occurred. This could be avoided by putting the longeron at the edge of the cut-out; shaping in section as Figure 16b, which has the distribution of area required.

Lack of Frame Reinforcing

Referring again to Figure 16a, the existing structure has a local reinforcing channel at W where the longeron cuts into the skin flange of the frame (Figure 7). At Y the only reinforcing is due to a flange from a 24G doubling plate.

At Z the frame is heavily reinforced by the cut-out edge angle.

Maximum frame loads occur at Y (Figure 15). This leads to frame stresses three times those found in the longeron and twice those elsewhere in the frame.

It is suggested that this could be prevented by continuing the reinforcing from the longeron frame joint to the cut-out edge member.

T A B L E I

DIMENSIONS OF TEST SPECIMEN - See Figure 2

Cylinder of 17 - 11" Bays (187") 100.6 outside diameter

SKIN 19G Uniform
+24G Doubler in Radius of Cut-out Corner.

STRINGERS Z Average Spacing 2.47"
A = 0.185 with 2" skin
I = .0359 inches⁴
 \bar{X} = 0.35" from skin.

LONGERON Maximum
A = 0.705 inches²
I = .305 inches⁴
 \bar{X} = 0.585" from skin.

FRAME Maximum
at cut-out A = 0.490 inches²
I = 0.227 (0.20 used as weighed
mean for calculation)
 \bar{X} = 0.74" from skin.

Mean of skin
tension and
Compression
Values,
See Figures
6 and 7.

CUT-OUT 24.5° and 25° }
From Horizontal Centre Line.

LONGERONS 25.5° and 29° }

Door edge 10G Mg angle otherwise D.T.D. 390.

Structure Symmetric about Vertical Centre Line.

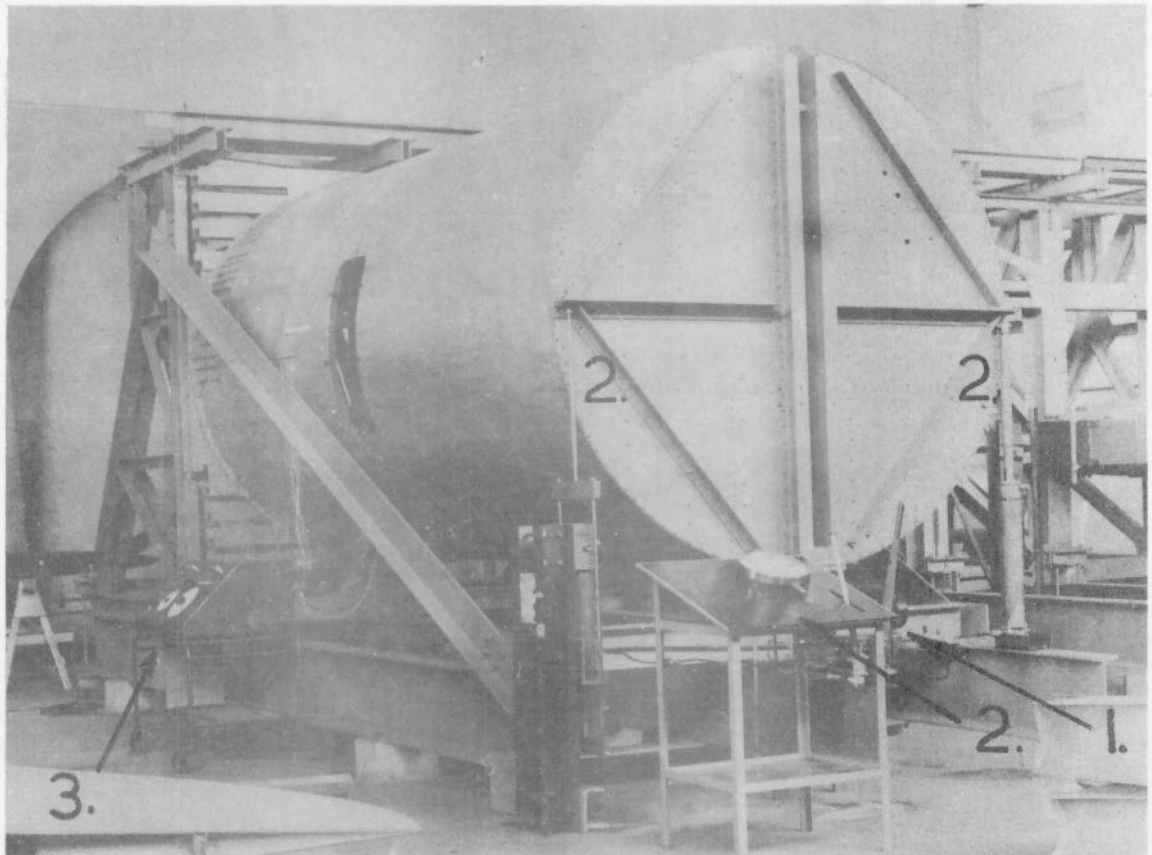

1. DIRECT SHEAR: HYDRAULIC LOADING RIG AND JACK.
JACK MOUNTED ON ROLLERS.
2. TORQUE: HYDRAULIC LOADING RIG AND JACK.
3. SAVAGE AND PARSONS TYPE STRAIN RECORDER.

TEST RIG AND SPECIMEN.

FIG. 1.

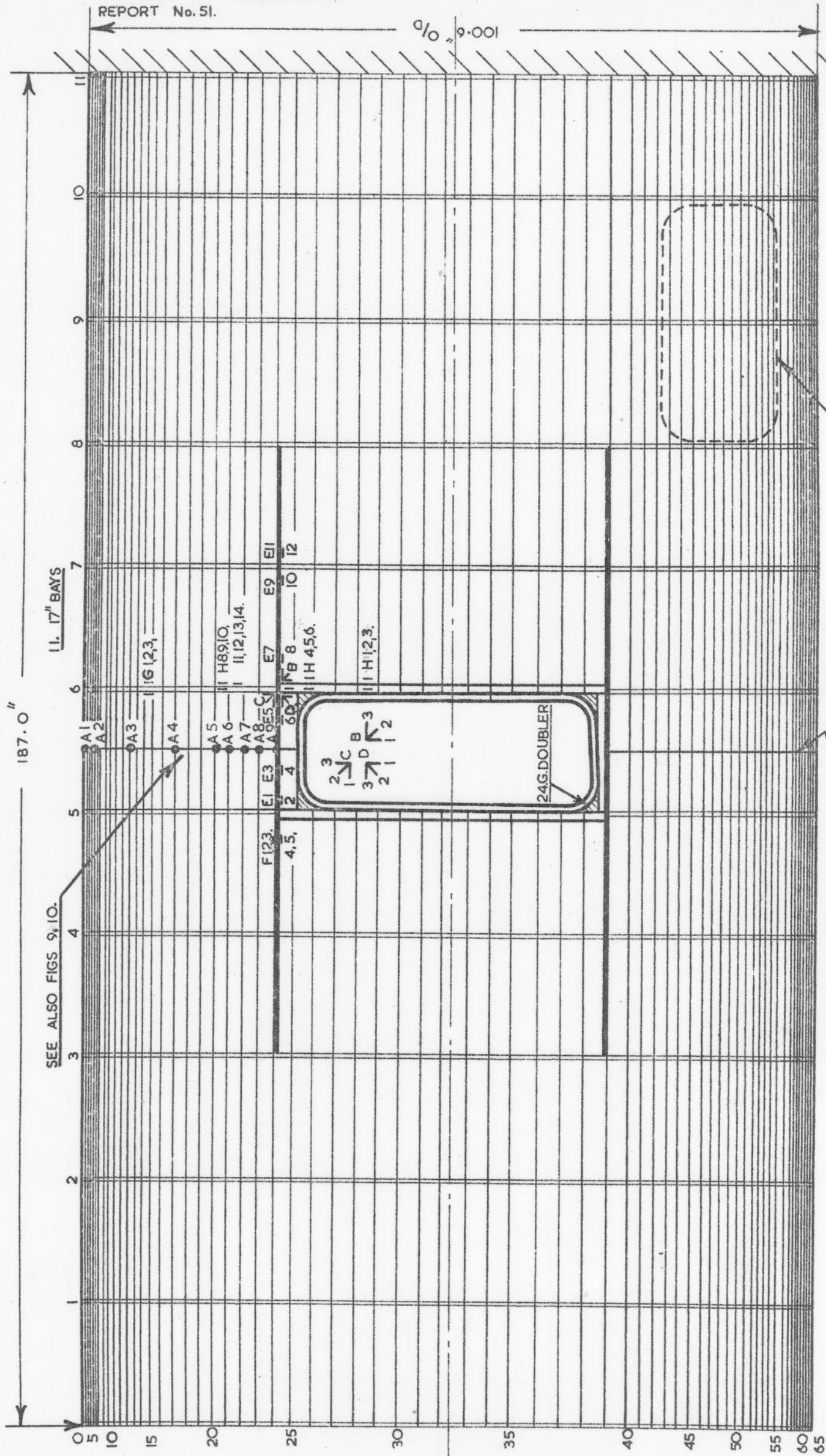
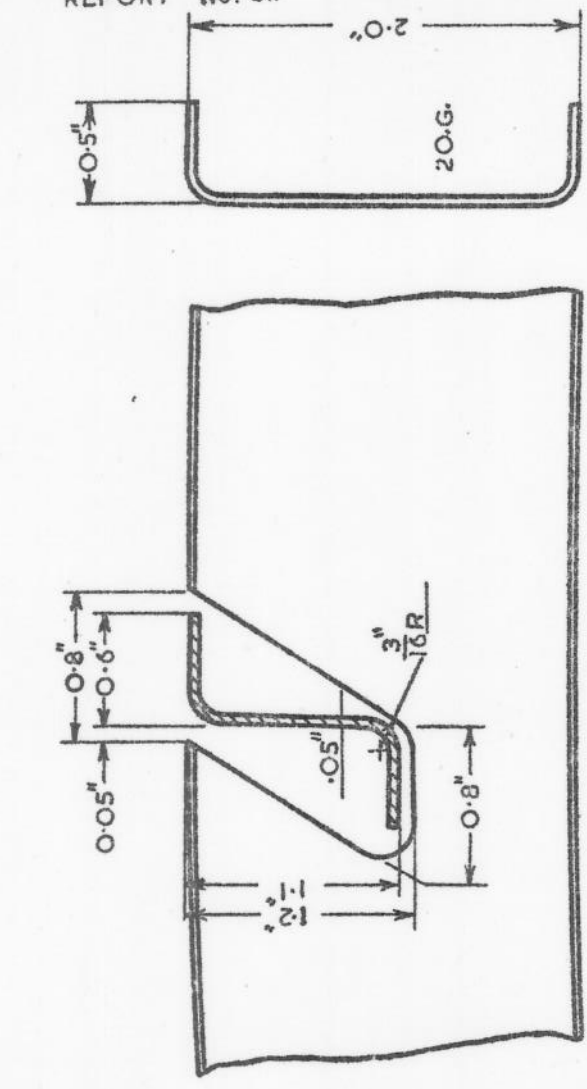

FIG. 2.

AS FIG. 10. LINE OF SKIN SHEAR GAUGES
ARRANGEMENT OF STRAIN GAUGES.

SYMMETRIC ABOUT VERT ϕ



STANDARD FRAME
SCALE: FULL SIZE

CHANNEL SECTIONS

- 1: 2" x .45" 19G
- 2,5: 2" x .70" 16G
- 3,4: SEE FIG. 6.
- 6: 2" x .60" 18G

ALL SECTIONS EXCEPT 3, 4 HAVE STRINGER CUT OUTS.

DOOR FRAME

SCALE: 1/16

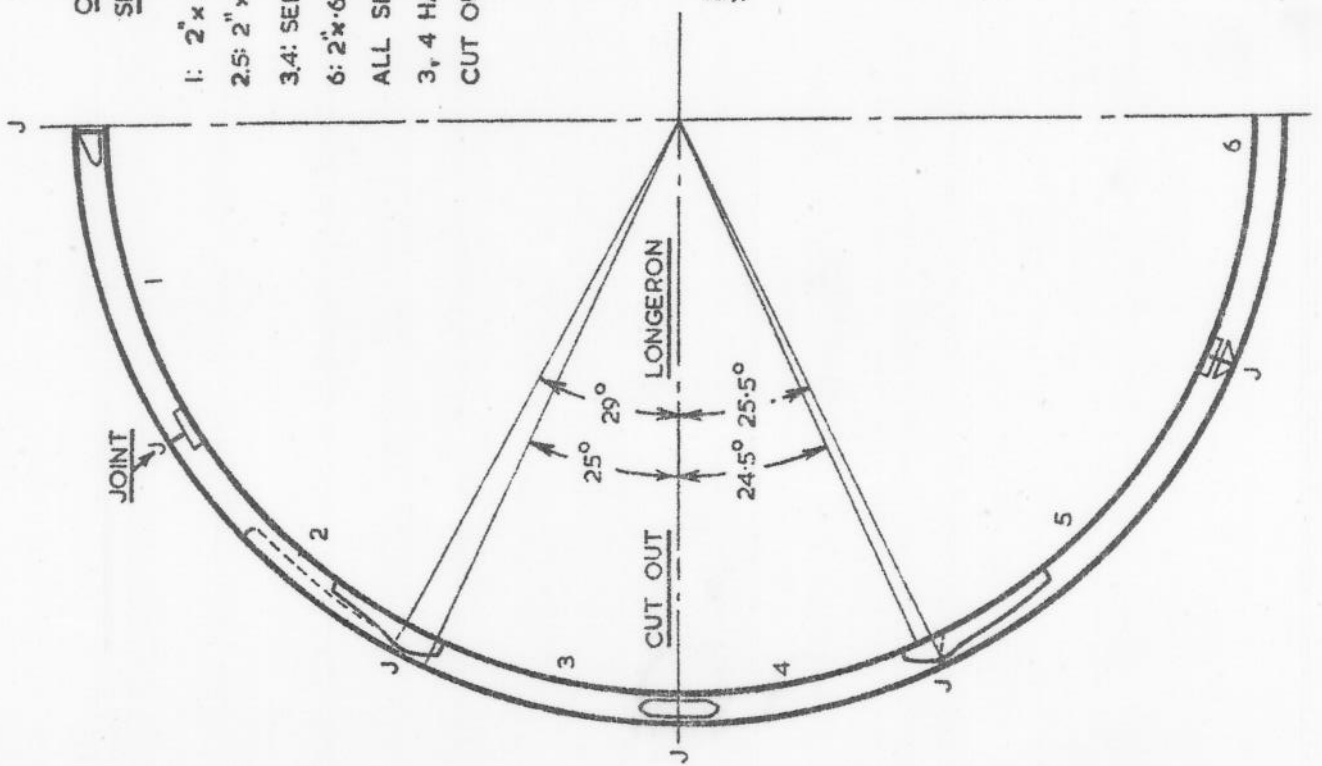

REINFORCED FLOOR LONGERON

SCALE: FULL SIZE
LONGERON REINFORCED WHEN FLOOR BEAMS REMOVED: NOT STRAIN GAUGED.

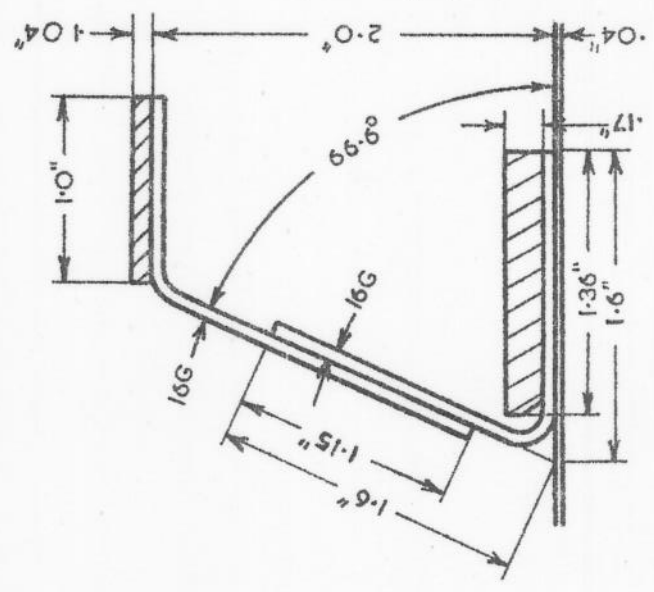

FOR FURTHER DETAILS SEE FIG. 6.7.

FIG. 3. DETAIL OF STRUCTURE.

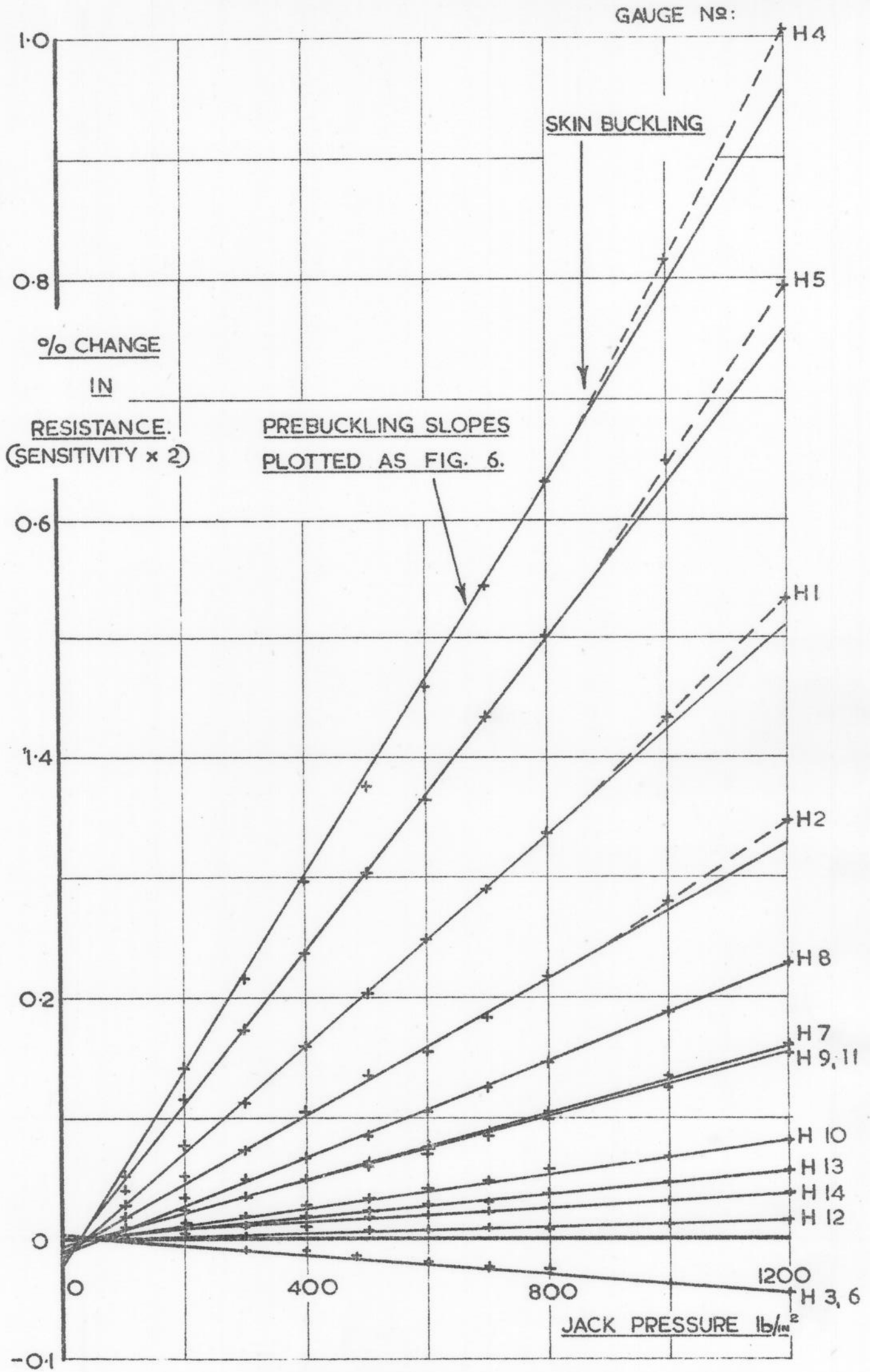

FRAME TENSION GROUPS.

FIG. 4.

EXAMPLE OF:

STRAIN GAUGE READING — JACK PRESSURE.

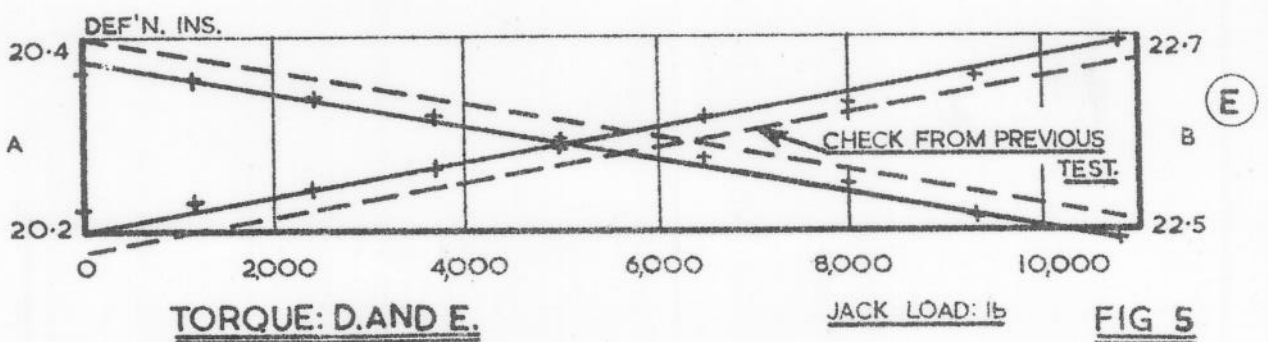
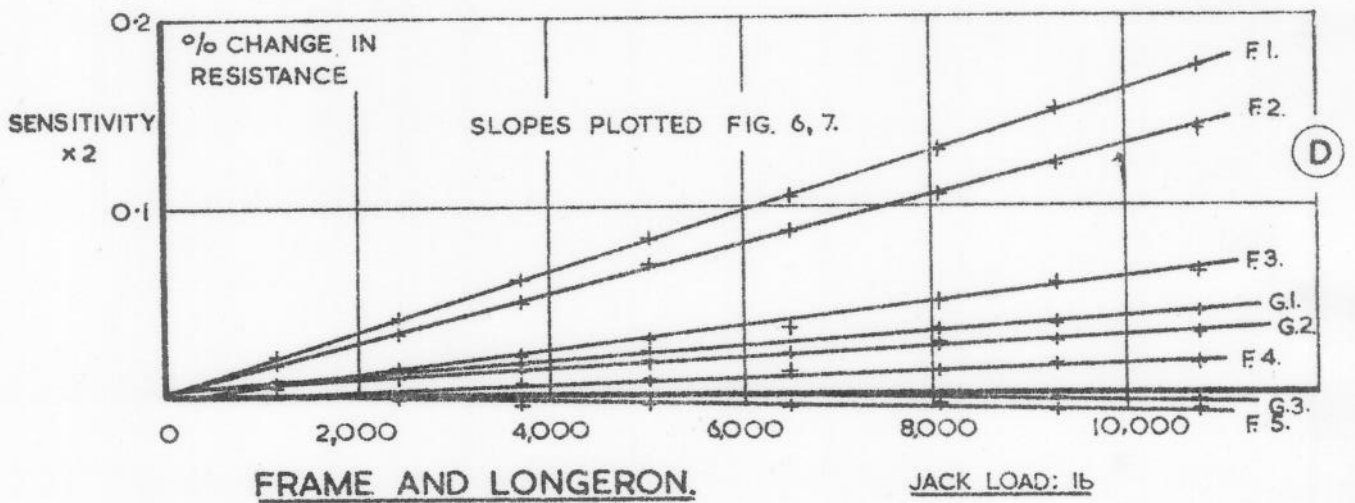
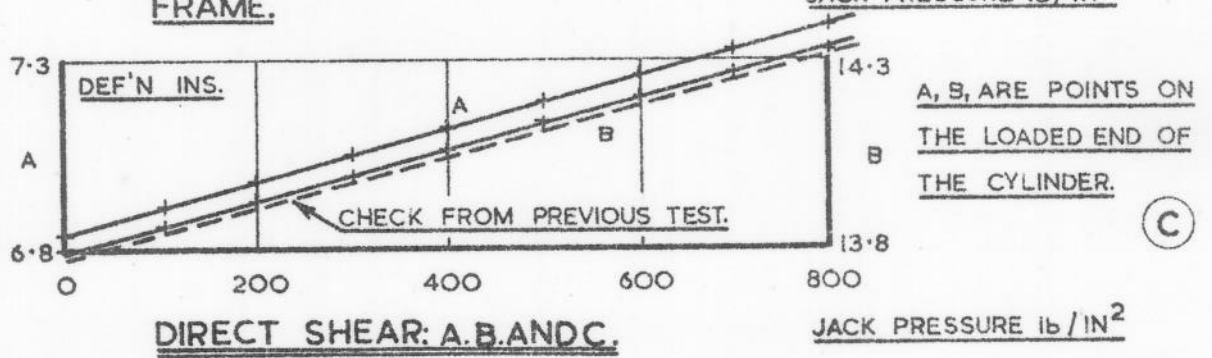
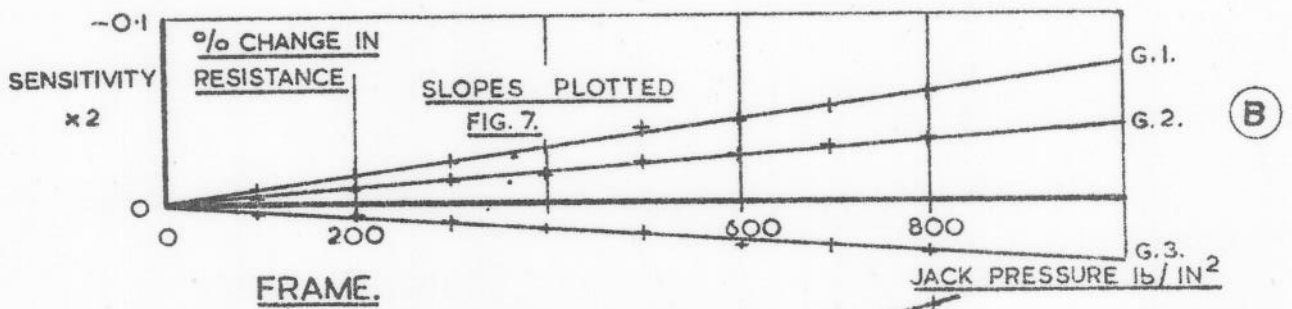
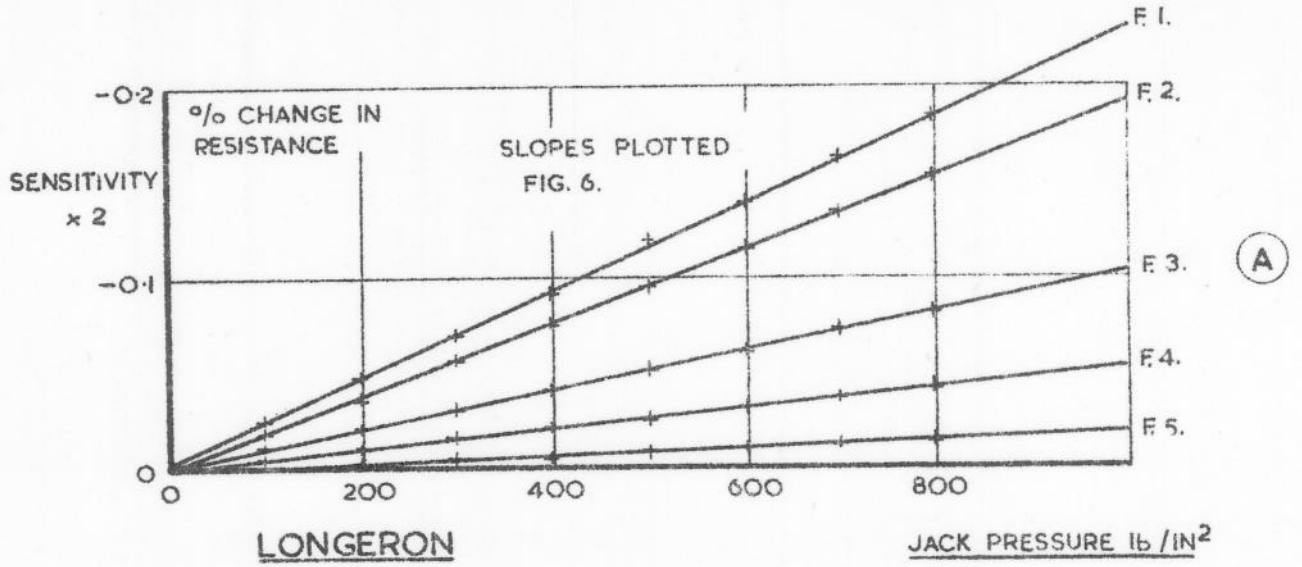

EXAMPLE OF: STRAIN GAUGE READING AND DEF'N — JACK LOAD

% GAUGE RESISTANCE CHANGE FOR: ΔT AND ΔW .

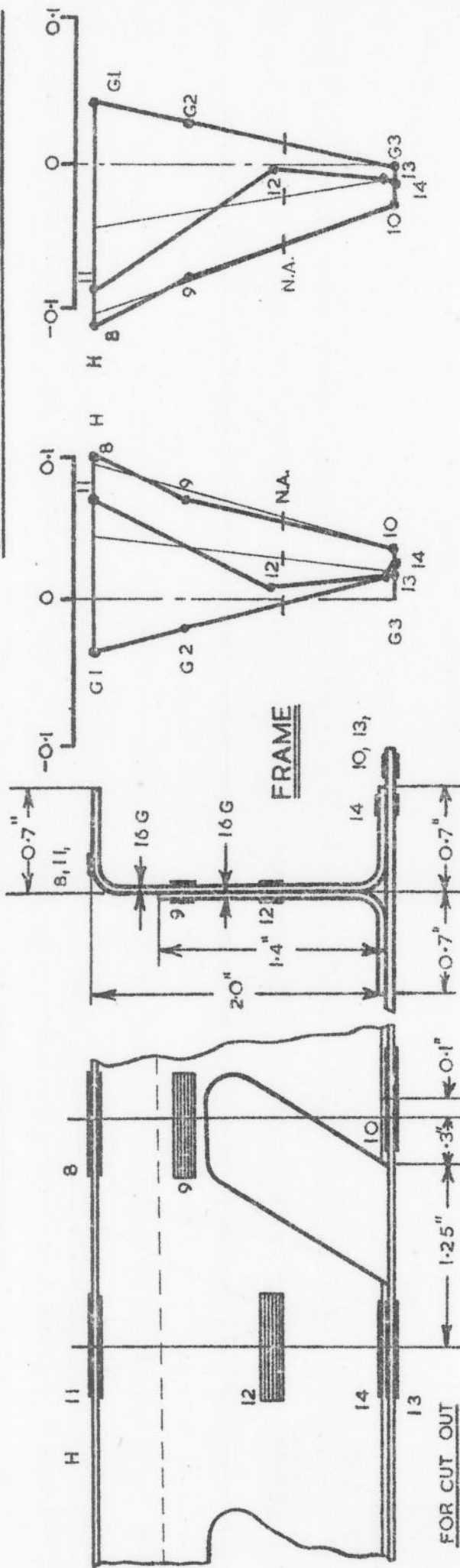

FOR CUT OUT
 SEE FIG. 8.

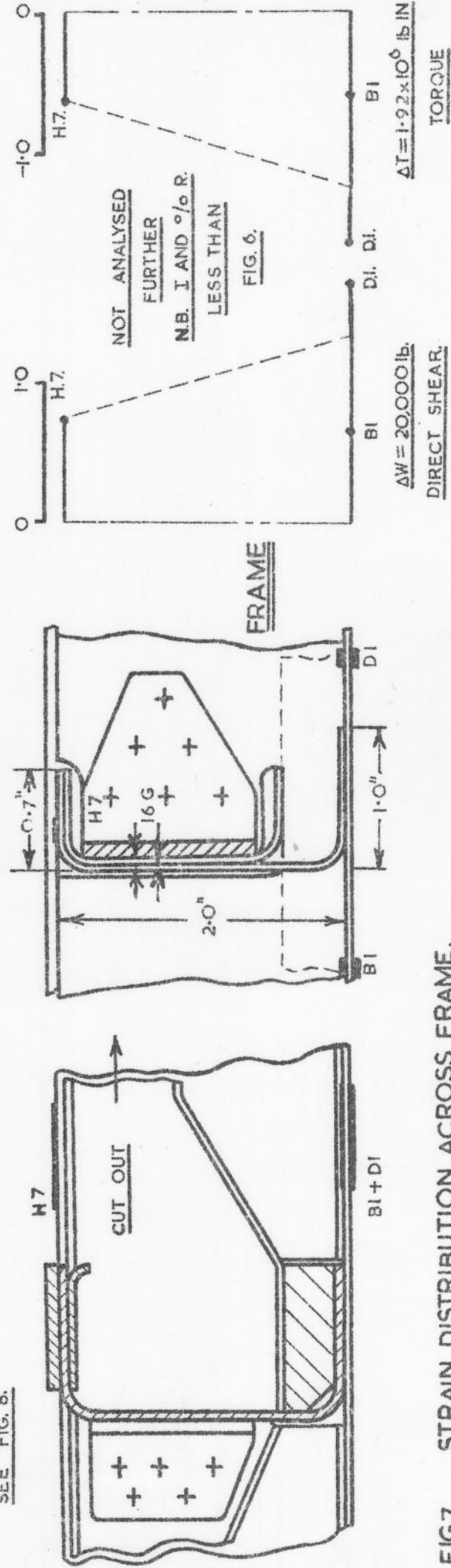
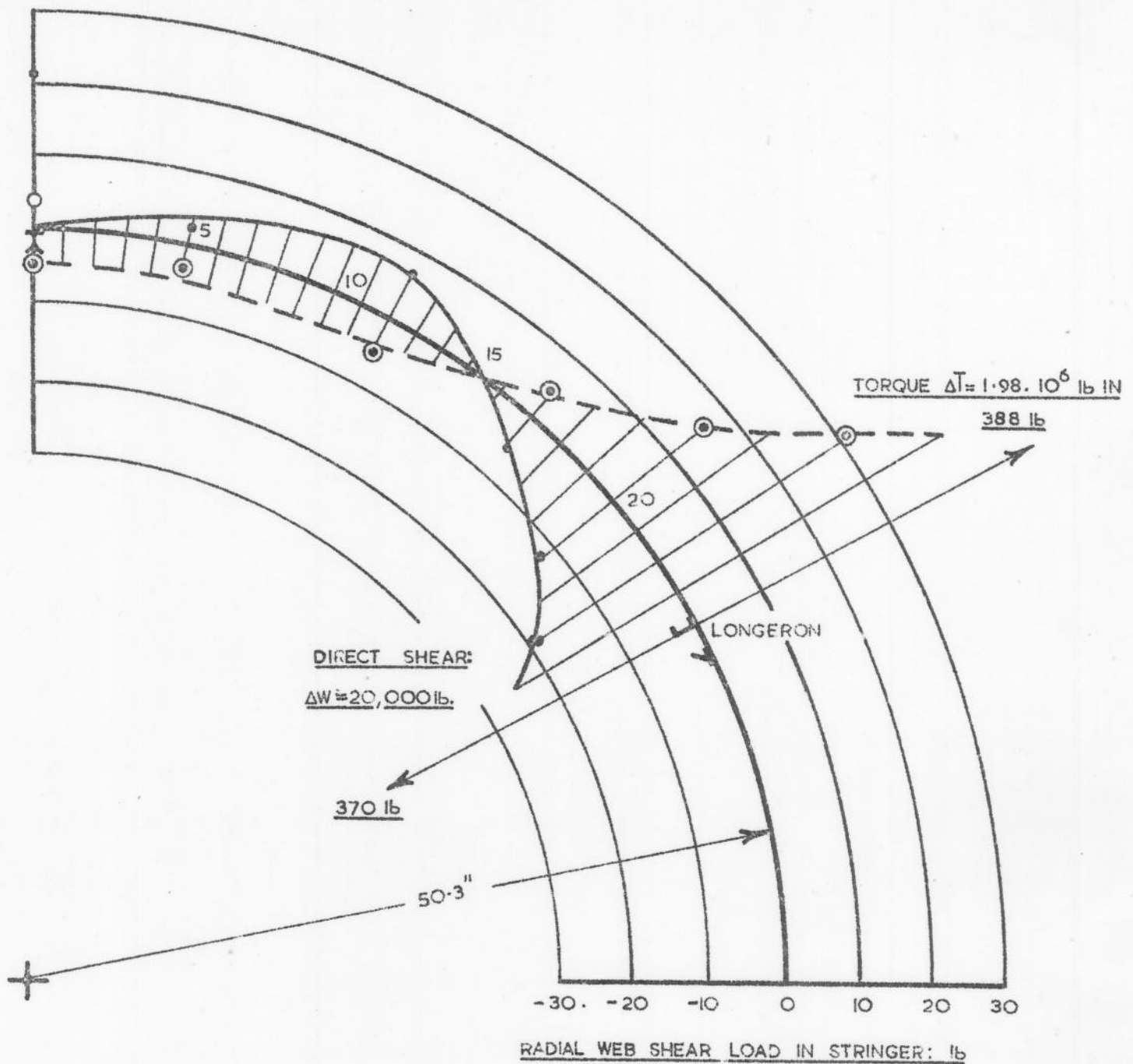

FIG. 7 STRAIN DISTRIBUTION ACROSS FRAME.



CHECKS:

$$\left. \begin{array}{l} 2^{\text{ND}} \text{ MOMENT OF AREA OF Z STRINGER} + 2'' \text{ SKIN} = 0.036 \text{ IN}^4 \\ \text{LONGERON} = 0.310 \text{ IN}^4 \end{array} \right\} \text{RATIO: } 8.6$$

$$\left. \begin{array}{l} \text{COMPARE MEAN EQUIVALENT RADIAL WEB LOADS.} \\ \text{STRINGER: } 45 \text{ lb.} \\ \text{LONGERON: } 378 \text{ lb.} \end{array} \right\} \text{RATIO: } 8.4$$

ALSO FROM FIG. 12, LOCAL SLOPE OF LONGERON BM. DIAG = .014 lb/lb.

(E. LONGERON SF APPROX 280 lb ($\Delta W = 20,000$ lb))

IN SECTION TESTED:

TOTAL OF COMPONENTS OF WEB LOADS ASSISTING SKIN TO
RESIST DIRECT SHEAR LOAD OF 20 000 lb; APPROX: = 250 lb.

I.E. TOTAL IS 5% OF ΔW .

FIG 8

STRINGER AND LONGERON WEB LOADS AT CENTRE OF BAY WITH CUT

OUTS

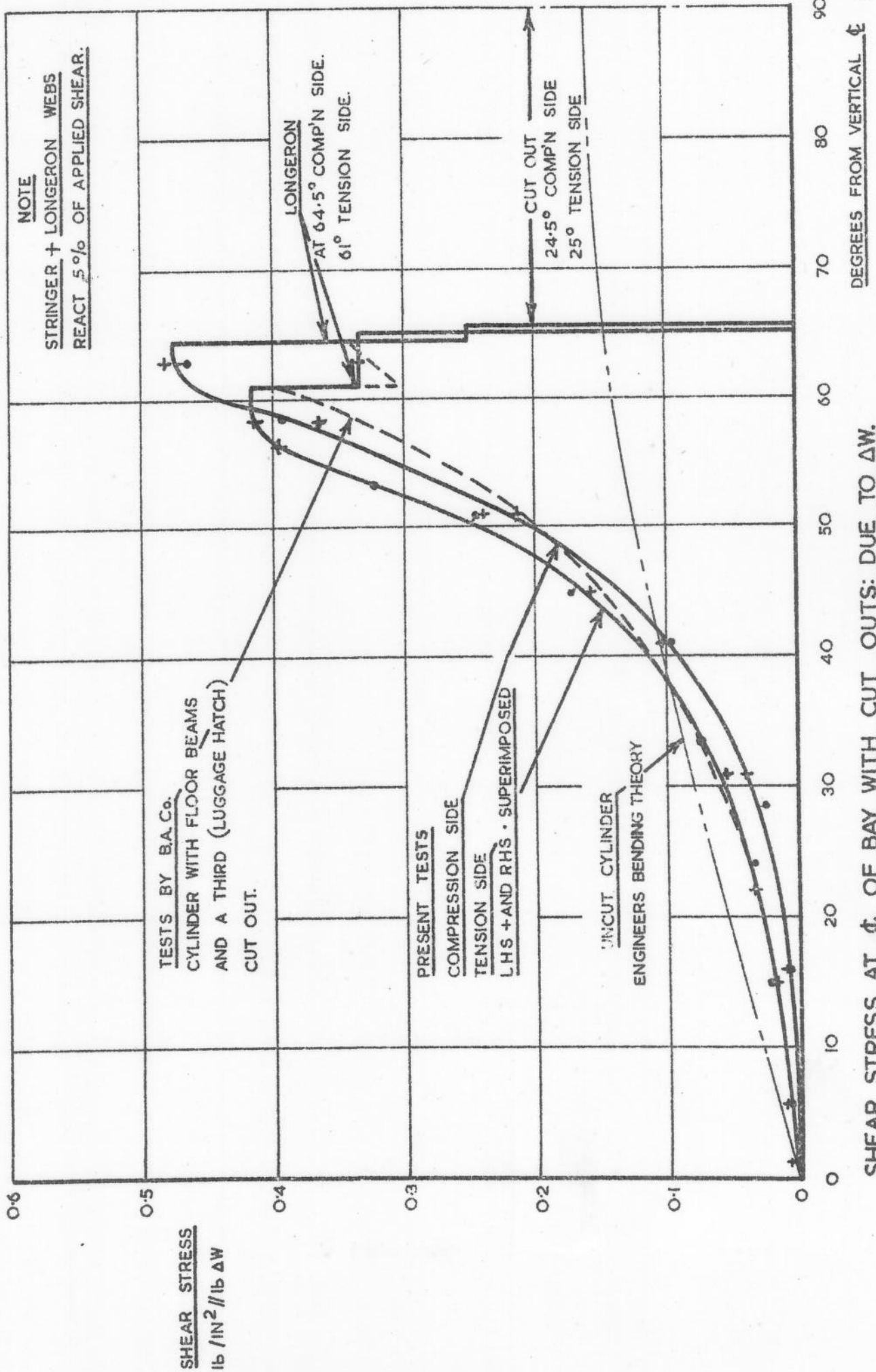

FIG. 9.

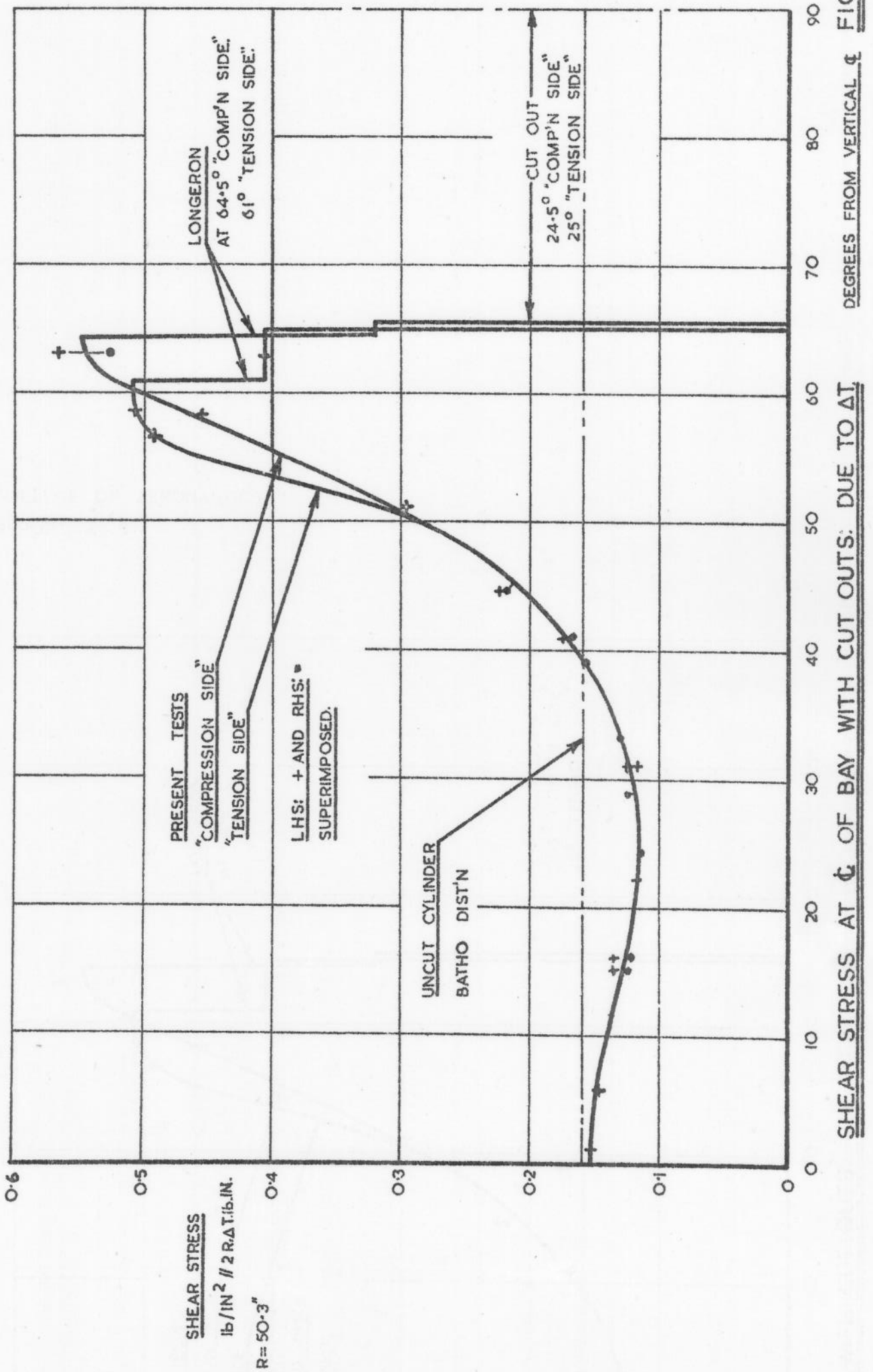
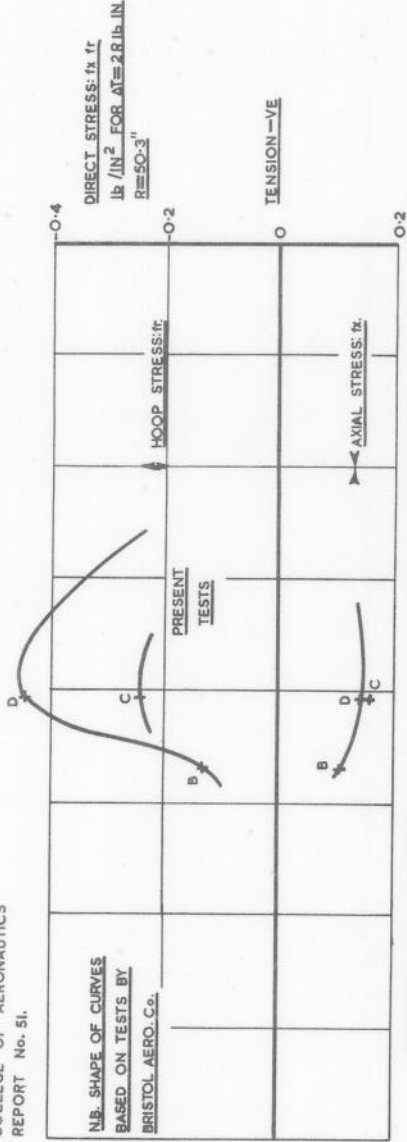
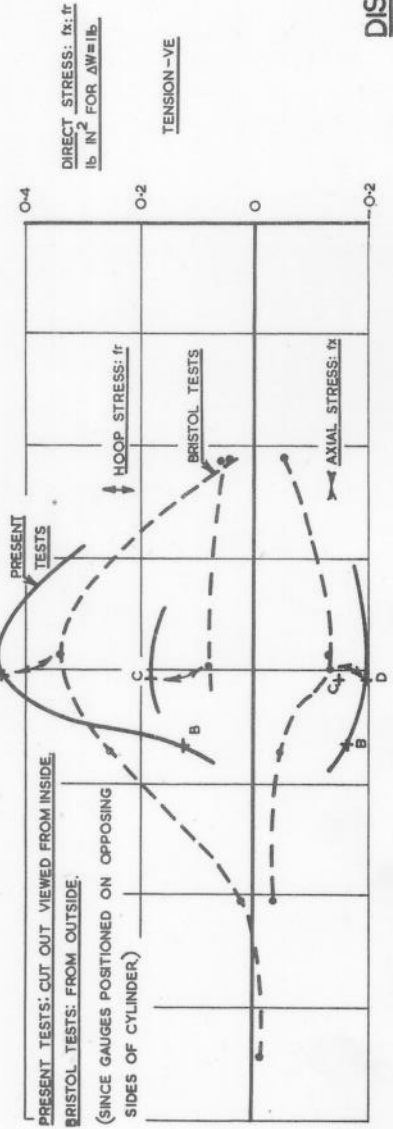
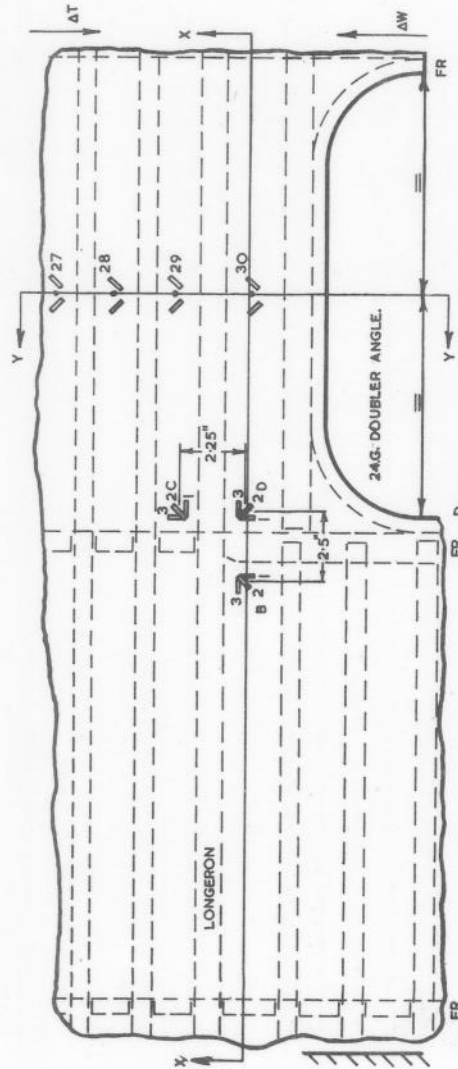

FIG.10.



SECTION XX. TORQUE.



SECTION XX. DIRECT SHEAR

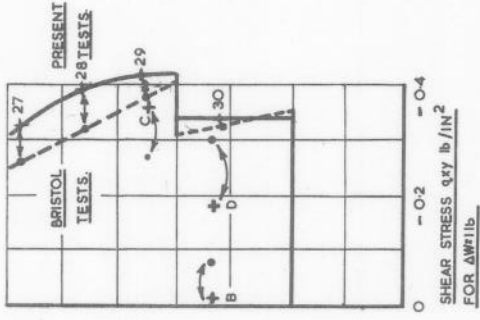

SECTION YY. DIRECT SHEAR.

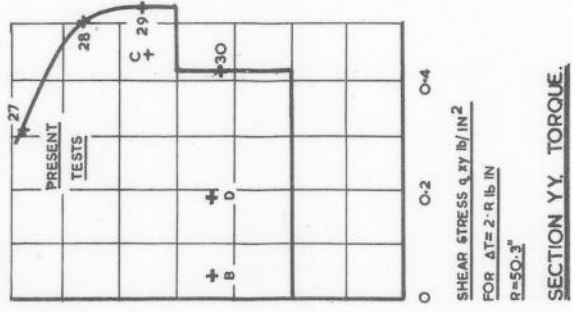

DISTRIBUTION OF DIRECT
AND SHEAR STRESSES

FIG. 11.

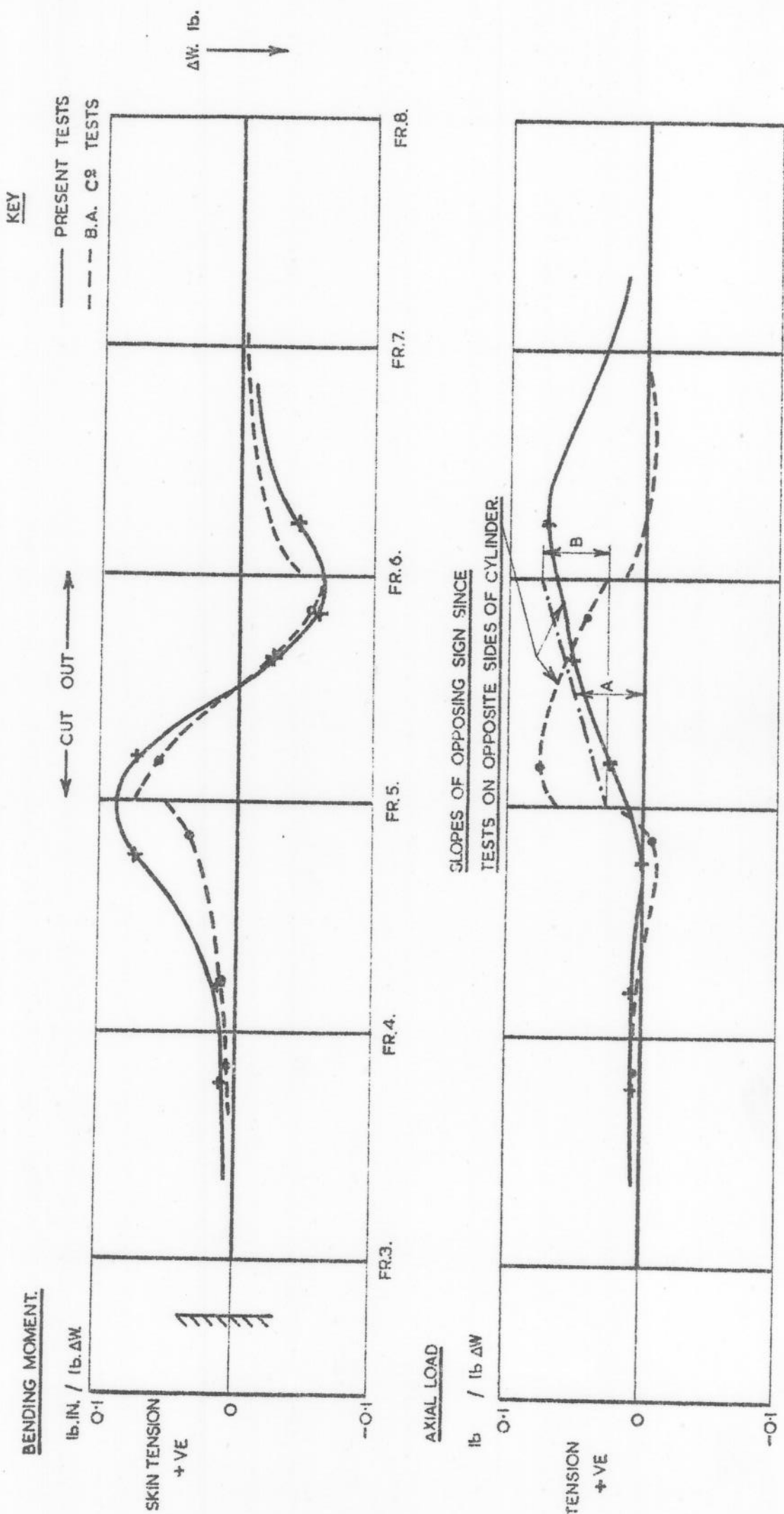

A : AXIAL LOAD IN LONGERON DUE TO BENDING (THEORY.)
B : EQUIVALENT AXIAL LOAD INCREMENT TO DISCONTINUITY IN SHEAR STRESS DISTRIBUTION FIG. 9.

NOTE: STRESS DUE TO BM. APPROX 5 TIMES STRESSES DUE TO A.L.

LONGERON LOADS: DUE TO ΔW (DERIVED FROM FIG. 6)
FIG. 12

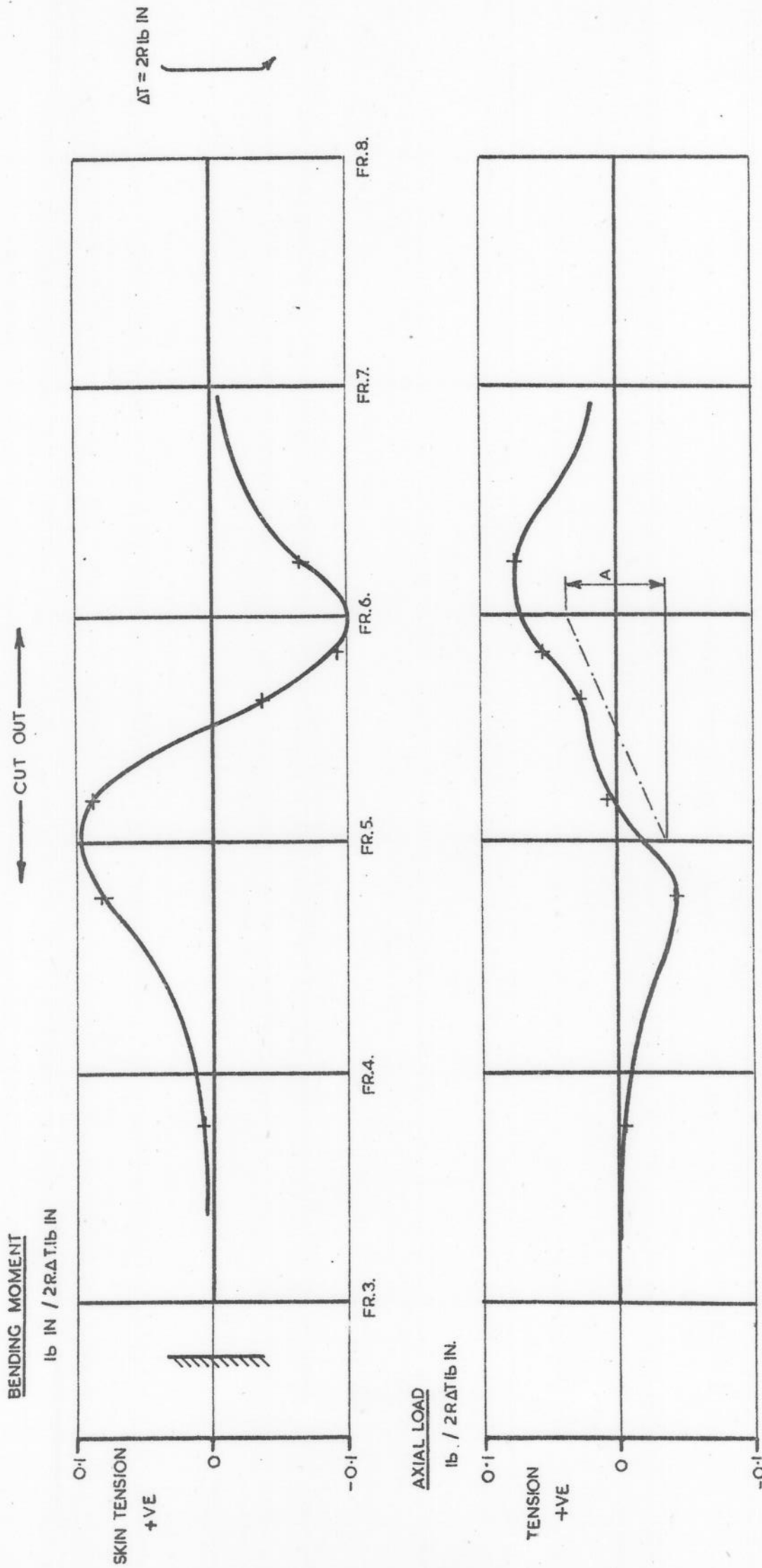

NOTE: STRESS DUE TO BM APPROX.
5 TIMES STRESS DUE TO A.L.

A: EQUIVALENT AXIAL LOAD INCREMENT TO DISCONTINUITY
IN SHEAR STRESS DISTRIBUTION. FIG. 10.

LONGERON LOADS: DUE TO Δt (DERIVED FROM FIG. 6.)

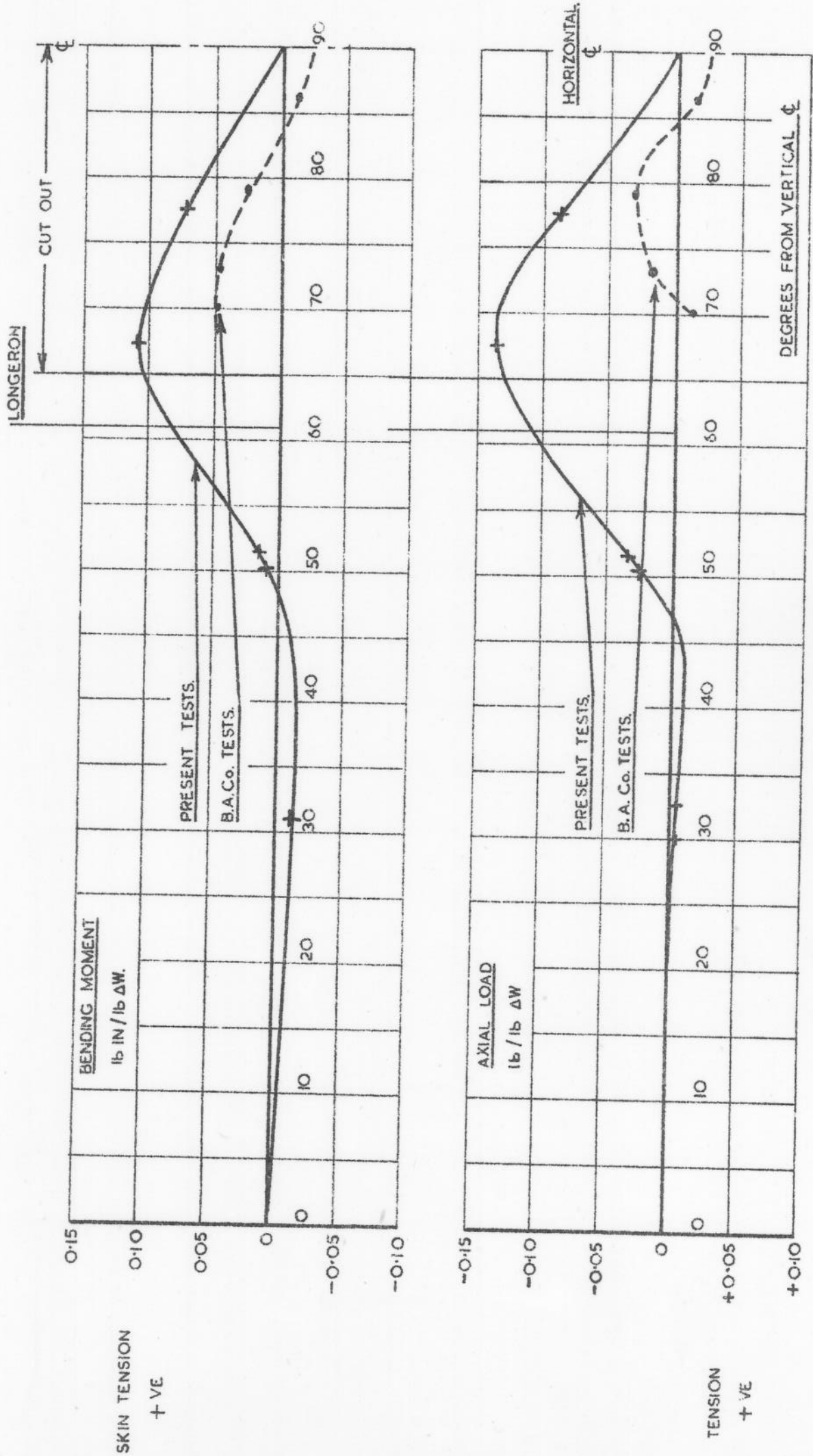

FIG. 14.

FRAME LOADS: DUE TO ΔW (DERIVED FROM FIG. 6 AND 7.)

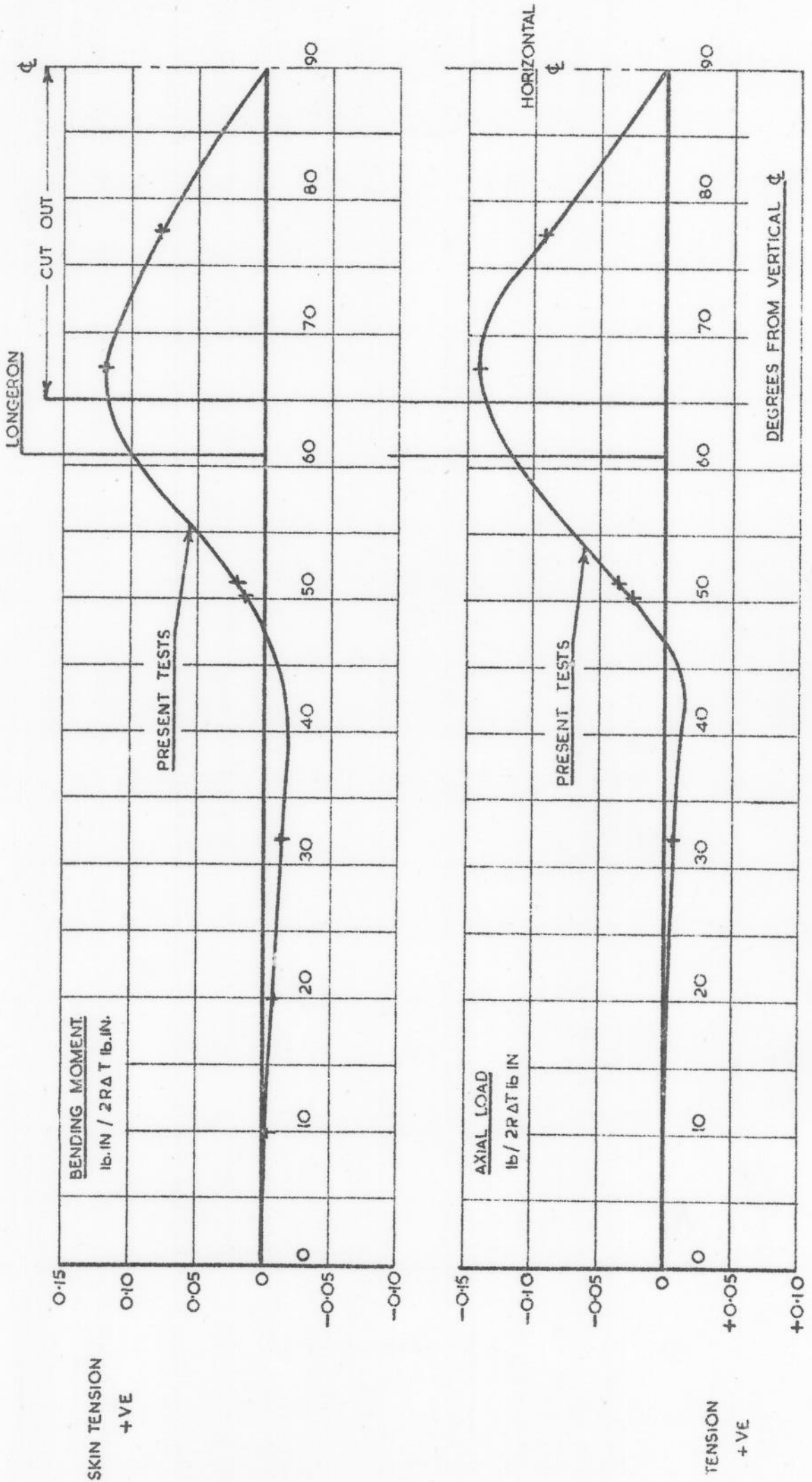
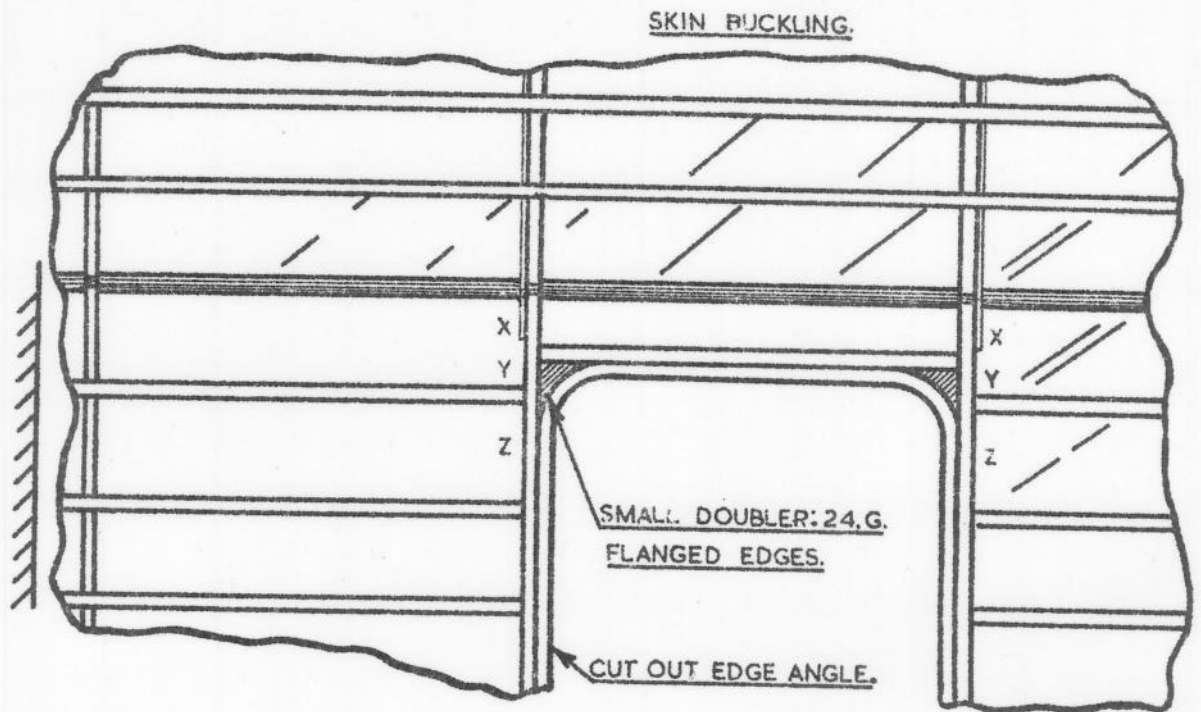
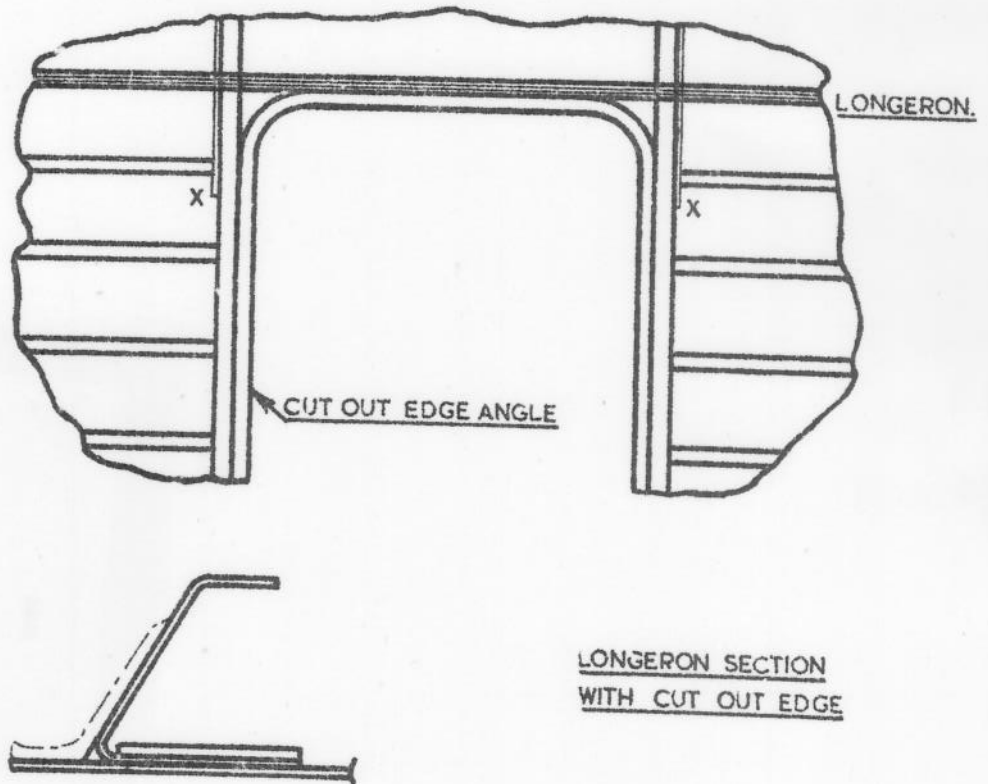

FIG. 15.

FRAME LOADS: DUE TO ΔT (DERIVED FROM FIG. 6 AND 7.)



(a) EXISTING STRUCTURE
NOT TO SCALE.



(b) SUGGESTED STRUCTURE
NOT TO SCALE.