

An Investigation into Set back Force simulation in Composition B fillings subjected to Hot Gun Scenarios

M.Cartwright and Lt(N) P. Delany

Department of Materials and Applied Science

Cranfield University at Defence Academy of the U.K

DCMT Shrivenham, Oxfordshire, SN6 8LA, U.K.

ABSTRACT

Ammunition loaded into large calibre gun chambers, which have been heated by previous firings, can enter a *hot-gun* state; conservatively defined as hot if 50 rounds or more are fired in a four-hour period. In this state the temperatures of the explosive fill, such as Composition B, may easily exceed their qualification temperatures. This is potentially dangerous if the weapon misfires either by cook-off or premature shell ignition. Currently there are no standard tests that can be used to assess the behaviour of Composition B filled munitions in a simulated hot-gun condition.

During firing some of the energy can be transferred to the explosive fill. Defects induced by melting and/or re-solidification of the Composition B will lead to a greater chance of accidental initiation of the explosive due to setback forces creating hotspots and ultimately resulting in an accidental in-bore explosion. The aim of this research was to investigate the conditions of this accidental initiation of Composition B in a hot gun situation at the time the projectile is likely to be cleared from the gun. It investigated whether this situation can be simulated cost effectively by examining the sensitivity of Composition B samples that were thermally conditioned in accordance with calculated temperature-time profiles. A target assembly was designed to mimic setback forces by using projectile impact. A series of tests conducted on these composition B filled targets, which had been subjected to hot gun conditions, were performed at the Cranfield Ordnance Test and Evaluation Centre (COTEC) to simulate setback effects at shot start. Mechanical energy was delivered by an impacting sabot launched from a nitrogen gas powered gun. Post firing simulation and analysis of materials were used to determine the mechanism of initiation and the severity of the event compared to the amount of force the samples were subjected to.

Introduction

Experience has shown that large calibre, in service, Naval gun fired projectiles are generally very reliable and safe. But a **hot-gun** situation creates a potentially dangerous state either for direct cook-off or if the weapon is fired for a premature misfire in the barrel. The temperatures of the explosive fill, in this investigation Composition B (RDX/TNT/Wax), may easily exceed their qualification temperatures. Composition B softens at around 70°C, begins to melt at 79.6°C and has a cook-off threshold of nearly 180 °C¹. Currently there are no standard tests that can be used to assess the behaviour of Composition B filled munitions in a simulated hot-gun condition².

When firing a large calibre gun of greater than 76mm, some of the energy can be concentrated in the explosive fill causing accidental in-bore explosion. The ignition mechanism in a prematurely initiated shell is considered to be the result of the conversion of mechanical energy into heat within the explosive from setback pressure during the firing. A number of mechanisms as detailed below have been proposed :-

Adiabatic Gas Compression

Pore Collapse and micro-jetting

Friction

Shear and viscous flow

These mechanisms produce hot spots in the explosive filling which can eventually end up in a run away chemical reaction. However set back forces can also deliver a shock wave to the filling. If the shock wave has sufficient peak pressure then a prompt shock to detonation, SDT, will result. However lower intensity shock waves can result in bond rupture, inducing a chemical reaction, which can release energy to the filling and thus support the shock wave which, if the system is confined, will steadily accelerate the burning front over a period of time and distance and a deflagration to detonation transition, DDT, will result. The distance and time required for DDT to occur is a function of peak pressure and the explosive displayed as pop plots². If the run up distance exceeds the munition dimension then DDT may not occur. Thresholds are affected by the duration of the pulse and the area over which the shock is delivered. For a flat cylinder impinging on an explosive sample the initial shock pressure can only be maintained over a conical region in front of the impactor³. Factors affecting the DDT transition are confinement,

particle size and density of the filling, configuration of the filling and the thermodynamics of the explosive, 'Q' value. It may also include sub-critical shock that is below the SDT threshold that will still run to detonation. Conditions that focus energy at localised regions within the explosive mix will give a higher frequency of initiation. Hence under the right circumstances the peak setback pressure can cause compressive heating of the gas voids in the explosive and may be enough to result in an in-bore explosion. Whilst careful attention needs to be paid to filling quality to eliminate air gaps, other sources of gaps, cracks and pores induced by melting and/or re-solidification of the Composition B will lead to a greater chance of accidental initiation of the explosive due to setback forces.⁴

A number of experimental assemblies have been designed to mimic setback force initiation. Both the Susan Test vehicle and the NSW set back simulator rely on delivering a shock impact to a sample of explosive confined in a moving vehicle. In the Susan test⁵ the explosively filled vehicle is fired from a gun and impacts on an armoured target plate. Notice that the explosive filling is subjected to two set backs. The first occurs on launch of the projectile and the second, larger, setback is delivered by the impact on the target.

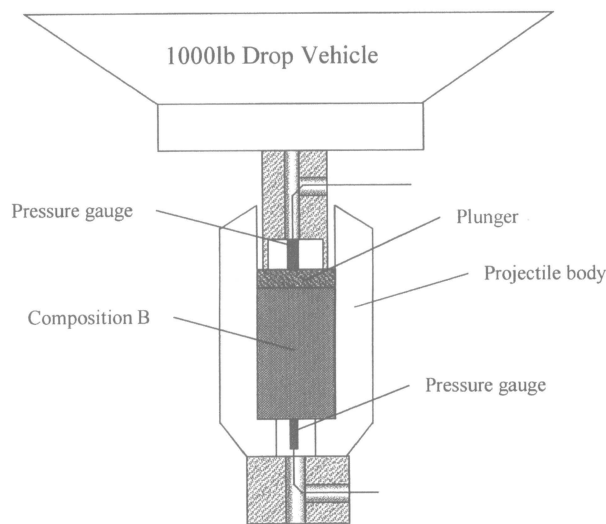

Figure Schematic of the NSW setback simulator

In the NSW setback simulator⁶ the vehicle falls under gravity and impacts on a metal anvil. Pressure sensors above and below the sample allow the shock wave progress through the sample to be monitored. A third system which applied a tri-axial compression

generated hydraulically allows some of the parameter necessary for modelling of the shockwave propagation to be determined but does not mimic set back forces accurately in the region of interest for our purposes.

This paper describes experiments designed to investigate the conditions of set back forces in a hot gun scenario, at the time the projectile is likely to be cleared from the gun, and if accidental initiation of Composition B could occur in a hot gun. The sensitivity of Composition B after it has been thermally conditioned to varying temperatures for different lengths of time has been investigated. These tests were performed in order predict filling vulnerability to accidental premature in-bore initiation within the Naval Gun environment and provide a fuller understanding of hot-gun clearance safety issues based on of the limitations of thermally shocked Composition B explosive fillings.

The Cranfield designed system used here was originally developed as a spigot intrusion assembly for investigating initiation mechanisms as described at a previous PARARI meeting⁷. However by judicious changes in the diameter of the spigot, 13 mm increased to 30 mm, and restricting spigot movement to 5 mm penetration enabled an impact from a sabot to deliver effectively a setback force to a confined explosive sample. Impact of a compressed gas gun launched sabot on one end of the impactor could deliver a suitable setback shock to an explosive sample mounted directly in front of the opposite end of the impactor in a confined system. There is no free volume for the explosive to expand into thus mimicking the conditions inside a gun launched munition. Calculation and measured pressures developed in a 4.5" naval gun suggest that peak set back pressures of around 270 MPa are normal⁸ and this can be converted by Newton's law $Force = mass \times acceleration$ to determine the acceleration the shell experiences. This can be converted back to the acceleration of the impactor into the explosive. The advantage of the Cranfield design is the reduced quantity of explosive used (40 g compared to 400 g of the other test vehicles) and the simplicity of target assembly.

Experimental

Target Assembly

A cross section through the test rig and final assembly are shown in the figure 2.

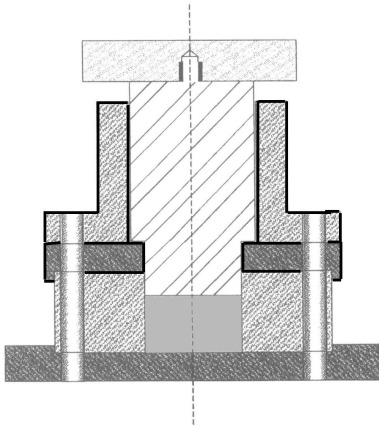

Figure 2 the Cranfield set-back simulator test vehicle

The test rig contains the explosive cast in a polypropylene plastic ring, 35 mm diameter and 21 mm deep, which is an interference fit into a steel ring of the same depth and 100 mm diameter. This is going to provide the confinement. This ring and sample are fitted into machined recesses in the top and bottom target plates. Mounted on top of the top plate is the piston carrier plate. All components are interference fits reducing the possibility of slap as the impactor slides in the carrier. The whole assembly is bolted together with eight high tensile steel cap head, 13 mm diameter bolts. The impactor will travel 5mm into the explosive sample, as shown in the figure, before it is arrested by the retaining lip on the top plate. This assembly is mounted on an A frame about one metre in front of the gas gun.muzzle

Gas Gun

The gun consists of a 2.5 m long steel tube, 50 mm diameter, which is closed at one end by a demountable steel plug . Around this end of the barrel is a concentric steel gas reservoir as shown in figure 3 . Vents in the side of the barrel which allow the gas to expand into the barrel are normally obscured from the barrel by the sabot which sits with the vents in between the two 'O' rings which seal the sabot in the barrel. The breech end of the gun is open to atmosphere as is the barrel in front of the sabot. Any gas seeping past the 'O' rings is thus vented. Operation of the firing button seals the breech and allows gas from the reservoir to fill the space behind the sabot forcing the sabot forward and uncovering the vents in the barrel wall producing a rapid gas expansion accelerating the sabot to the desired velocity.

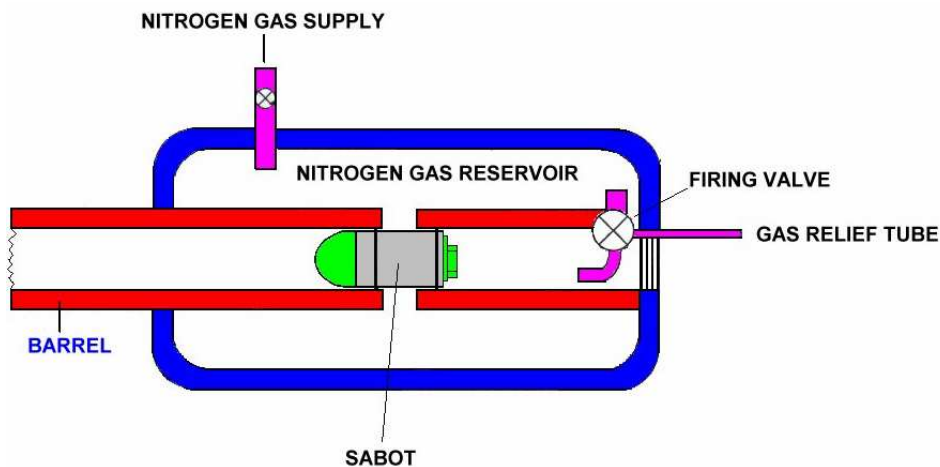

Figure 3 schematic of the compressed gas powered gun

Sabot velocity was determined by measuring the time taken for the sabot to break a series of insulated copper wires stretched across a plastic tube, mounted in front of the muzzle on the guard assembly designed to provide protection to the muzzle, through which the sabot passed see figure 6. Breaking the wires produced a voltage pulse which was measured by a fast recording oscilloscope. One of the wires also triggered the fast video recording.

Explosive samples

Composition B (60:40 RDX:TNT) was supplied by B.Ae. Systems Ltd Glascoed to MOD specification and was used without further treatment. 400 g of the mixture was heated in a beaker on a boiling water bath at 90 °C. When the sample was completely molten it was poured into a series of the plastic supporting rings placed on a water bath heated metal plate. The plate was then removed from the heat and allowed to slowly cool in a cooling blanket. Any piping was filled with additional molten material. The samples were examined by SEM and x-ray for the quality of surface finish and absence of voids.

Thermal Conditioning

A study into hot-gun effects in larger calibre Naval guns^{2,9} identified the region closest to the driving bands as receiving the heat transferred from the hot gun and determined the advance of the molten contour line into the Composition B filling as a function of time. These profiles are shown in the diagram .

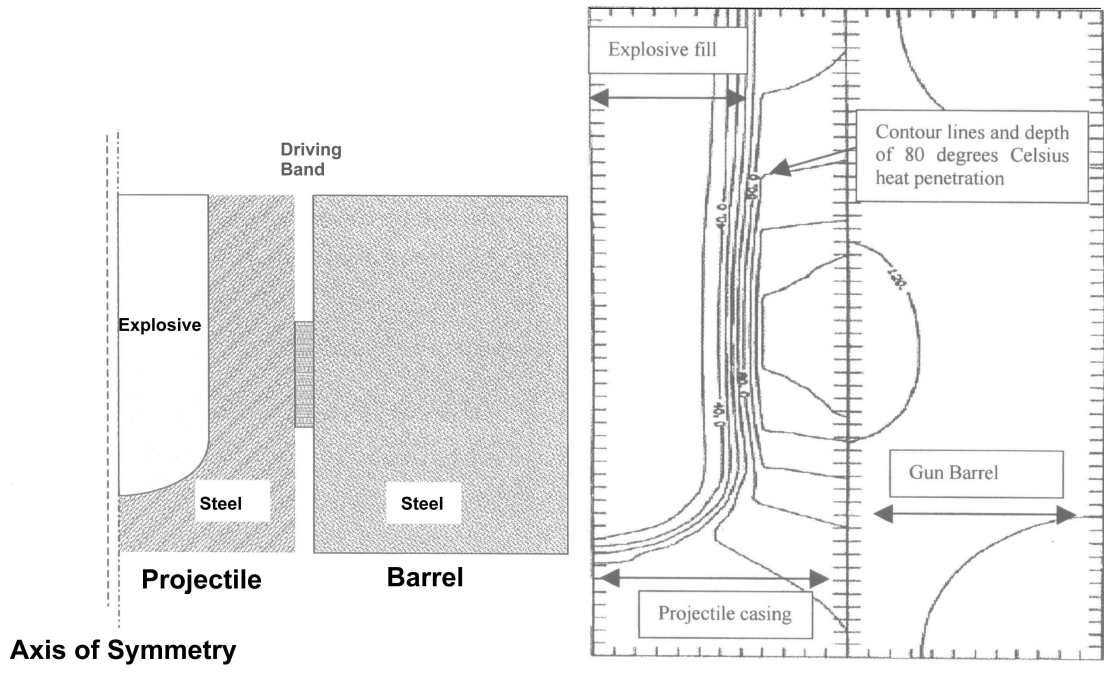

Figure 4 Area of contact between projectile and Barrel and the depth contour lines for the 80°C heat penetration as a function of time

The other factor is the number of rounds and the frequency of firing in the salvo. There is only a significant effect of ambient conditions for a small number of rounds. Typical temperature projectile temperatures for salvos are shown in figure .

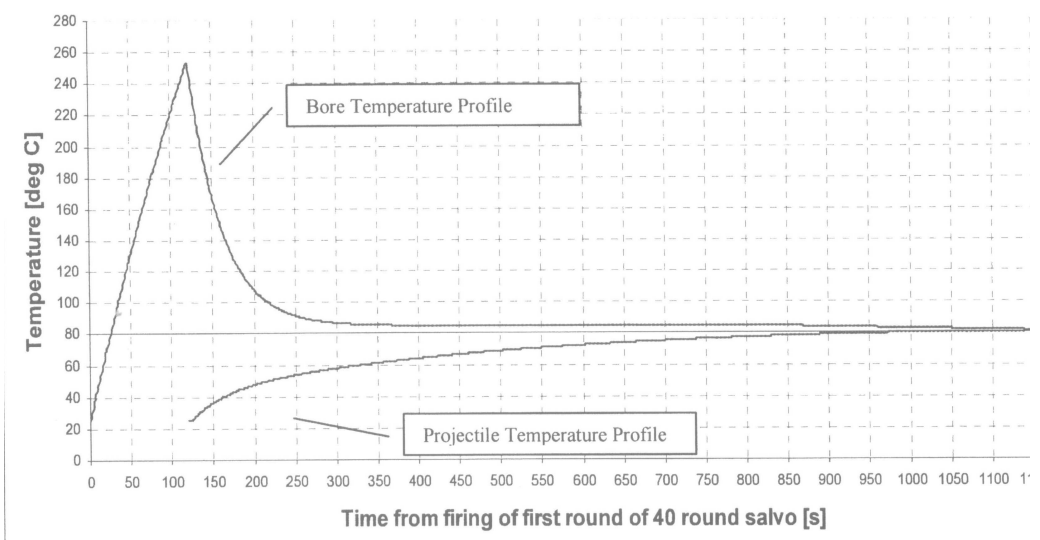

Figure 5 time temperature profile for a projectile and barrel in a hot gun scenario

These profiles were used to determine the most appropriate thermal conditioning times for the test samples. The figure shows that about 10 minutes after firing the first shot in a 60 round salvo at 20 rounds per minute the filling will have a considerable molten TNT zone in contact with the projectile walls which will still be in contact with a barrel at $> 85^{\circ}\text{C}$. As a result some of the targets in the confining ring and base plate were placed in ovens at 80 and 85 oC and heated for 10 or 15 minutes at each temperature since our calculations suggested that these were the critical hot gun conditions. Samples were then re-examined by optical microscopy prior to mounting in the target assembly. The target was mounted on the support frame in the test cell on the COTEC ranges at West Lavington. A series of firings were performed at different sabot velocities and the events monitored by a high speed video camera.

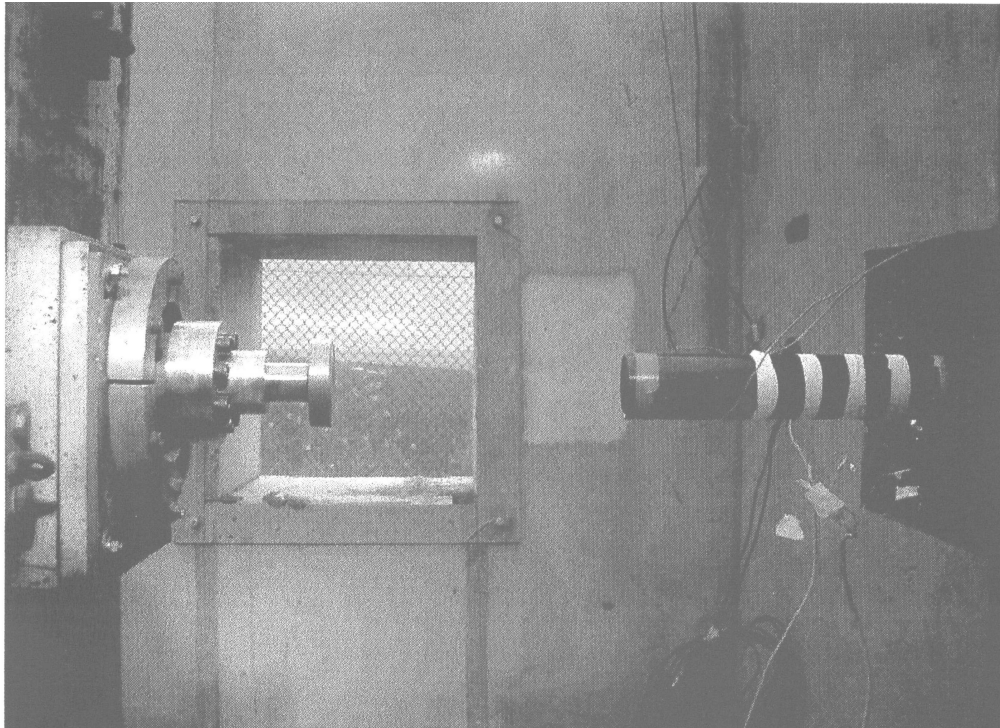

Figure 6 showing target assembly in front of velocity measuring tube attached to the gun barrel with the high speed video camera window

Results

Microscopy

Electron microscopy of the as cast and thermal treated samples is shown in the figure 7. The defects present in the as cast samples are minute surface flaws resulting from the treatment to ensure no piping or excess material standing proud of the confining ring which could produce problems when the target was assembled. As the annealing time and or temperature are increased then the defects present increase. Annealing for 10 minutes at 80oC showed significant problematic regions whilst 15 minutes anneal at 85 produced extensive migration of the TNT leaving almost pure RDX exposed on the surface. Notice these figures are obtained after thw samples had cooled back down to ambient. Post impact analysis of the Composition B sample used in shot 4 showed extensive presence of shear banding and also granulation of the charge with possible recrystallisation of the TNT see figure 7 bottom right hand image

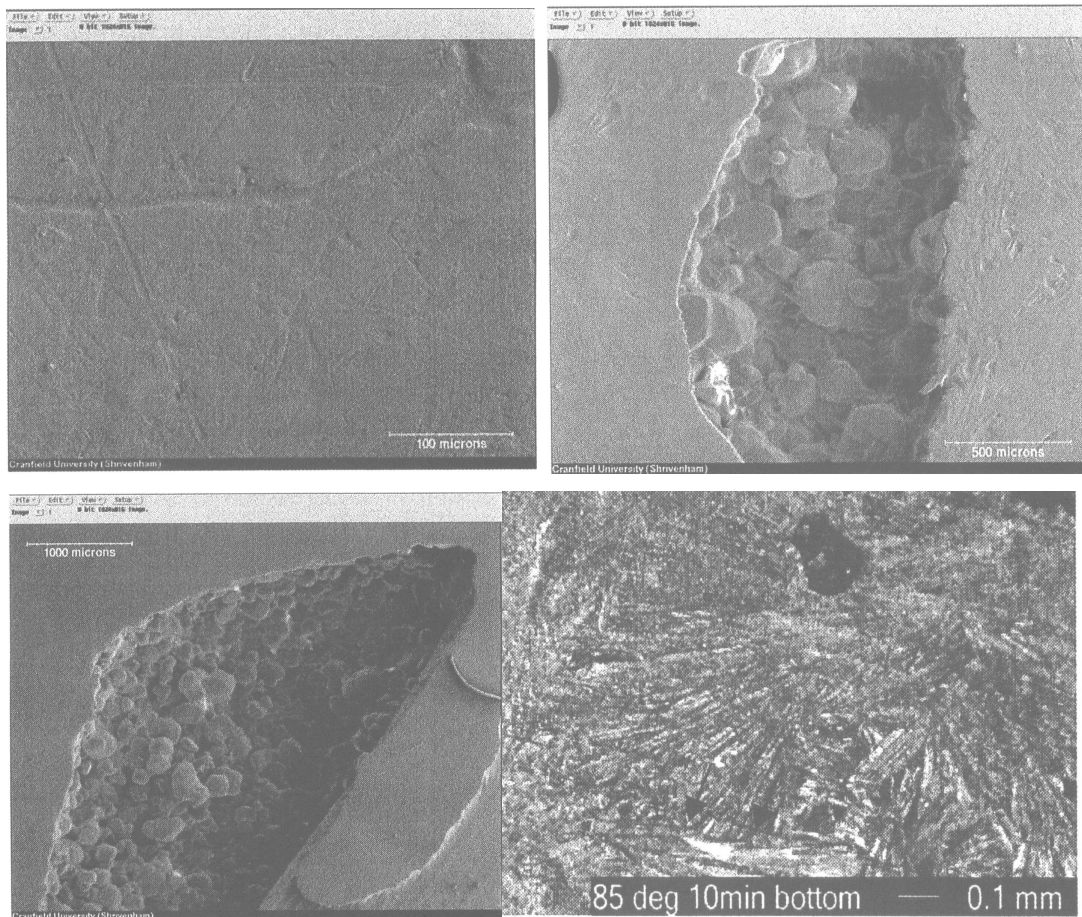

Figure 7 Electron Microscopy of composition B castings top left as cast top right 10 minutes anneal at 80 bottom left 15 minutes at 85°C and fragment after impact

Modeling

The functioning of the impactor assembly was undertaken using the Autodyn3DTM. This ensured the vehicle integrity would be maintained under the impact pressures and to identify where the peak pressures would be developed within the sample.

Impact Results

The results of the impact firings are summarised in the table 1 below. Notice that the setback pressures calculated are around the maximum design pressure for a 4.5” Naval gun with the exception of the first shot which was around the design set back acceleration but in excess of the design pressure. This firing was used as a calibration of the measuring and firing systems and produced the worst case scenario in terms of the resulting event

Table 1 Details of sample conditioning and Firing parameters for Composition B targets

Shot	Velocity of sabot	Impactor Velocity m s^{-1}	Setback acceleration $\text{m s}^{-2}/10^5$	Setback pressure MPa	Thermal conditioning	Event type
1	98.0	41.4	1.61	944	Ambient	Go(DT?)
2	76.1	32.2	1.04	569	10 min 80o	Go(DF)
3	67.3	28.4	0.81	444	10 min 85o	Go(DF)
4	51.9	21.9	0.48	265	15 min 80	No Go
5	51.9	21.9	0.48	265	15 min 85o	Go(DF)
6	54.4	23.0	0.53	290	Defect 20o	Go(DF/T)

Shot 1 was above the predicted setback acceleration for a 4.5” Naval gun and the simulated setback pressure was well in excess of the normal conditions in the gun and as a result a major event was observed. The test rig was destroyed and metallographic analysis of the fractured bolts indicated an energetic failure on the boundary of deflagration/detonation confirming the appearance of the base plate. Shot 2 also destroyed the test rig but the event was much less vigorous and definitely a deflagration. Shot 3 was similar but with a longer duration and some material being ejected from the target and continuing to burn in the air.

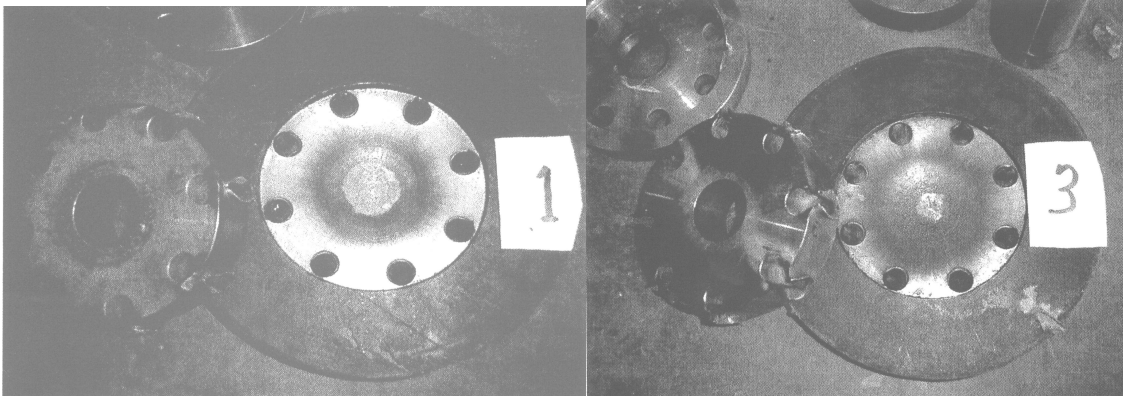

Figure 8 showing the base plates and confining rings for firings 1 (l) and 3(r).The first firing has run to detonation whereas the third firing is only a deflagration/ burn

Shot 4 produced no event of any description the filling was hydraulically squeezed in the space between the confining ring and the base plate as a result of the stretching of the high tensile bolts by ~2 mm allowing the thin disk to form see figure 9 below.

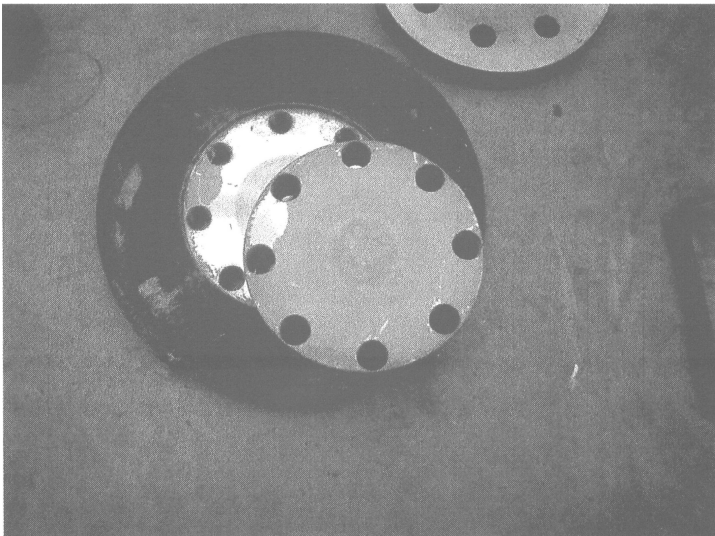

Figure 9 showing the hydraulic squeezing of the composition B filling between the base plate and the confining ring with no ignition evidence apart from a slight odour.

Shot five showed a limited event which occurred after the end of the impactor travel indicating that this trial may be on the threshold for initiation. A number of large fragments of charred composition B were recovered indicating a very limited event.

Shot 6 was by way of an anomaly in that our earlier examination had shown that post casting it contained defects and air pockets. So this sample was fired to show that under normal firing pressures the presence of cracks or voids rendered the filling unsafe.

Discussion

Due to time and finance constraints only a limited number of trials were performed but nevertheless there has been a significant effect demonstrated. The attempt to simulate set back forces with the impact rig design has proved very effective. Both the acceleration and the setback pressure can be simulated by the experiments with the rig. It would be beneficial to measure the impact load with some strain gauges to see how the pulse is delivered. The results confirm the calculations based on measurements of the heat delivered by the hot barrel to the projectile and also the anticipated effect of these temperatures on the filling. Even extended exposure in a hot gun barrel is unlikely to produce temperatures at which cook-off will occur, $<180^{\circ}\text{C}$ but more likely the filling will be sufficiently sensitised to produce premature initiation in the barrel should such a projectile be fired after a 10 minute exposure to 80°C . The pressure at which no event was obtained in this study is well below the operating pressure of a 4.5" naval gun hence the probability of a premature initiation under normal operating conditions is significantly increased as a result of the projectile being subjected to hot gun exposure. There is no doubt that the thermal conditioning described here mimics the effects in hot guns calculated for projectile conditioning. Without exact determination of the defects present in the thermally conditioned samples it is impossible to assign the increased sensitivity to a particular mechanism i.e. gas heating or shear etc. It is likely that a combination of mechanisms is responsible for the increased sensitivity. Results obtained in this study compare very well with the data provided by the NSWV drop setback simulator as shown in the figure. Perhaps because of the reduced confinement present in the COTEC target, lower pressures and reduced rate of pressure change are required for an event in this study but follow parallel lines to the NSWV data.

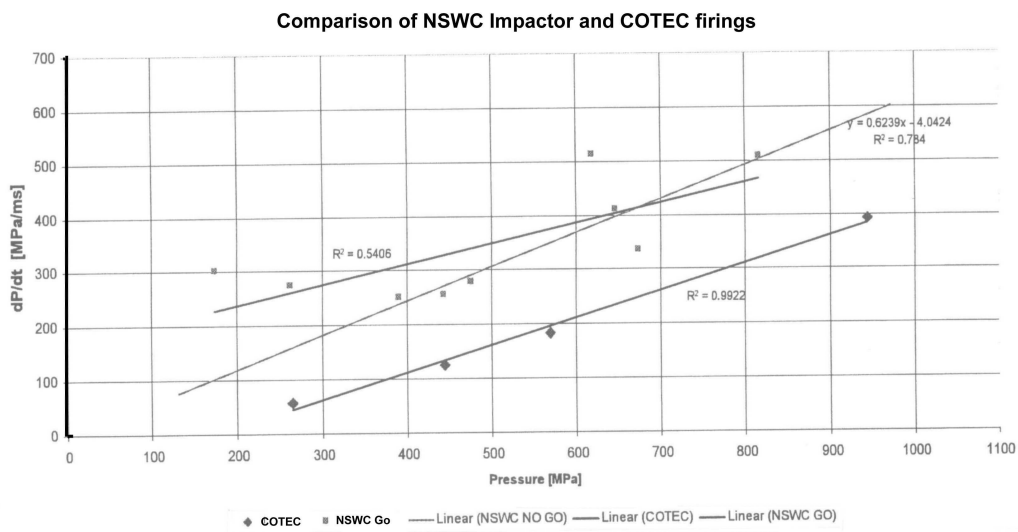

Figure 10 Comparison of NSWC and COTEC results for Composition B

Additional tests need to be performed to give good statistical reliability to the data but the principle conclusions about the hot gun scenario are unlikely to be changed by further data.

Further trials in which the sample is held at 85°C during the firing process will more exactly mimic the hot gun scenario but that is a more demanding task.

Modification of the confining ring to mimic the cup arrangement present in a shell would give enhanced confinement under impact perhaps providing a closer model to setback conditions.

Altering the aspect ratio of the sample could also provide further data about the effect of setback. As the modelling shows considerable pressure is generated at the bottom of the target and this may be effected by the length of the sample filling. A study of lower velocity impacts in previous work¹⁰ has shown that the rate of input of the energy is important and this may be one of the reasons for the differences between the NSWC data and this studies data. Our projectile velocities are higher than the falling mass velocities so lower energy inputs could be required for initiation

Conclusions

The impact rig designed for this study can accurately mimic the setback forces delivered by a large calibre naval gun to a projectile.

Thermal conditioning of the target samples used in this study can also mimic the conditions experienced by a projectile in a hot gun scenario.

Increase in exposure time to the hot gun conditions increases the sensitivity of the Composition B filling.

Projectile exposed to hot gun conditions are unlikely to cook-off but after 10 minutes exposure are likely to suffer premature initiation if fired under normal propellant conditions

The effect will depend on the number of rounds and the rate at which they are fired but as an elementary precaution rounds left in a hot gun scenario for 10 minutes should not be fired.

References

¹ Lester, C., Lynch, K. (1994). *Hot Gun Effects on Composition B Filled 4.5" Naval Ammunition*. DSTO-TR-0028. p8

² Cooper P.W. "Explosives Engineering" John Wiley and Sons Inc. London (1996) p312

³ Conic section impactor

⁴ Smith, D.L, Parry, M.A. (1988). *Clearing of Live Ammunition from Hot Guns*. Materials Research Laboratory Report MRL-R-1122 (Restricted). Melbourne. p-15

⁵ Service text book of Explosives JSP 333 M.O.D. London 1988

⁶ Meyers T. Hershkowitz Proc Seventh Int. Symp. on Detonation (1981) p 914

⁷ Cartwright M, Lewis A., and Wallace I.G. "Use of a gas gun to investigate Initiation Mechanisms" Parari 2005

⁸ Moss G.M. Leeming D.M. and Farrar C.L. "Military Ballistics a Basic Manual" Brassey's London (1995)

⁹ Nicolaides S. Velicky R and Voight H. Propellants Explosives and Pyrotechnics, 16 299 (1991)

¹⁰ Cartwright M., Wallace I.G., Williams M. and A.G. Jones "Vulnerability of Explosives to Low velocity Impact" 32nd United States Department of Defense Explosives Safety Seminar 22-24 August 2006