

# The Impact of Multi-Stack Fuel Cell Configurations on Electrical Architecture for a Zero Emission Regional Aircraft

Bahareh Zaghari\*, Tianzhi Zhou†, Hossein Balaghi Enalou‡, Evangelia Pontika§, and Panagiotis Laskaridis¶  
*Cranfield University, School of Aerospace, Transport and Manufacturing, Cranfield, MK43 0AL, UK*

**All-electric aircraft can eliminate greenhouse gas emissions during aircraft mission, but the low predicted energy storage density of batteries ( $=0.5$  kWh/kg), and their life cycle, limits aircraft payload and range for regional aircraft. Proton Exchange Membrane Fuel Cells (PEMFCs) using hydrogen are explored as an alternative power source. As the effort on designing high power density and highly efficient fuel cell systems continues, a trade off study on the effect of fuel cell configurations and the electrical conversion strategy on system efficiency, total weight, failure cases, and reduction of power due to failures, will inform future designs. Introducing viable fuel cell stacks and electrical configurations motivates such a trade off study, as well as concentrated design effort into these components. Currently available fuel cell stacks are designed at lower power (in the range of 150kW) to what is required for regional aircraft propulsion (in the range of 4MW). Hence to achieve the total required power, the fuel cell stacks are connected in parallel and series to create multi-stack configurations and provide higher power. In this study, multi-stack fuel cell configurations and the selected DC/DC converters are assessed. Each configuration is evaluated based on power converter design and redundancy, design for high voltage, degradation of fuel cell stacks, total system efficiency, and controllability of fuel cell stacks.**

## I. Introduction

**H**YDROGEN and electrification technologies promise complete decarbonization given that their implementation challenges are addressed [1] in comparison to hybrid electric propulsion with batteries [2]. Spinelli et. al [2] presented a methodology to study the trade offs between environmental compatibility, in the form of  $\text{NO}_x$  emissions and fuel consumption for a hybrid electric regional aircraft. Electrifying aircraft with hydrogen Fuel Cells (FCs) offers great potential to reduce fuel consumption and emissions, while satisfying the high power demand required for aviation. Currently, their application is limited to advanced research program that considers the use of FCs as a replacement of Auxiliary Power Units (APUs) [3], and more recently in the propulsion of small and commuter aircraft (ARPA-E, REEACH projects). In 2016, the world's first fuel cell and battery powered aircraft, a 4-seater DLR-HY4, flew for 10 minutes [4]. In this design, batteries powered take-off and climb, and hydrogen fuel cells provided 80kW of power in total to the rest of the flight profile. DLR is also working on the BALIS project from January 2021, to develop a fuel cell powertrain for regional aircraft (40+ seats, 1000km and 1.5MW) [5]. In 2021, ZeroAvia's 6-seater fuel cell aircraft flew for 20 minutes [6].

Different propulsion architectures and configurations with fuel cells have been explored in [7] and their benefits were discussed. Propulsion requirements were considered for high altitude operation, high sensitivities to system weight and volume, high differences in power during different mission phases, and compatibility with the current aviation infrastructure and certification processes. Architecture selection directly affects the efficiency, hydrogen consumption, and water vapour output, thermal, and energy management strategies of fuel cell systems, their life cycle, and their performance degradation. Electrical power train configurations must be assessed according to the selected fuel cell configurations. This paper demonstrates possible configurations for fuel cell stacks and the electric power trains, and

\*Lecturer in Propulsion Integration, Centre for Propulsion and Thermal Power Engineering, bahareh.zaghari@cranfield.ac.uk

†Ph.D Student, Centre for Propulsion and Thermal Power Engineering, tianzhi.zhou@cranfield.ac.uk

‡Research Fellow, Centre for Propulsion and Thermal Power Engineering, hb.enalou@cranfield.ac.uk

§Research Fellow, Centre for Propulsion and Thermal Power Engineering, evangelia.pontika@cranfield.ac.uk

¶Professor, Centre for Propulsion and Thermal Power Engineering, p.laskaridis@cranfield.ac.uk

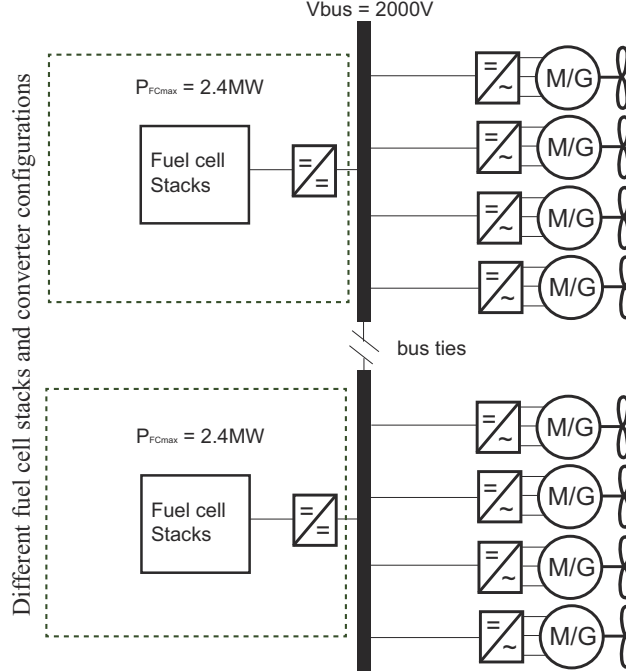
assesses their impact on electrical component design, as well as system efficiency, total weight, power losses and energy management strategy, and the selected mission.

Scaling the fuel cell technology, electrical systems, and the propulsion architecture for larger aircraft is currently beyond the state-of-the-art fuel cell systems technology, since MW-levels of power are required while maintaining a low aircraft weight. Fuel cells have higher specific energy, shorter refuelling time, longer life, and lower emission with non-carbon sources hydrogen harvest of in comparison with batteries [8]. However, their low specific power, low efficiency, high thermal losses of the stacks and the auxiliary system, water vapour output and lack of hydrogen-provision at airports, remain as considerable design and logistical challenges. The specific power of existing commercial fuel cell stacks is approximately 1.6 kW/kg[9]. The specific power of the fuel cell stacks (based purely on the active component of the fuel cell) is studied in [10], which 10kW/kg is estimated for future developments. However, this threshold does not assume that fuel cell auxiliary parts and the hydrogen tanks are incorporated into the design. Kadyk. et al [11] proposed a fuel cell sizing methodology, based on the relation between efficiency and power density. They proposed that, by oversizing the fuel cell, the required power from each stack reduces, achieving greater efficiency. This paper does not conduct a study on the influence of extra weight resulted due to oversizing the stacks for the required mission power. Also, in this study the influence of oversizing the fuel cells on energy management strategy has not been explored.

There are several studies that include more detailed electrical system level analysis and simulation: Kasim et al [12] developed a pure FC for Cessna level aircraft applications, where a complete fuel cell system was simulated, and the holistic flight mission simulation of the system was conducted, concluding that a fully hydrogen powered 8-passenger aircraft is feasible. A failure analysis of the system was also included. Zeng et al [10] presented an integrated fuel cell and aerodynamic model for a 30kW level two-seat aircraft. Hartmann et al [13] presented a comprehensive PEMFC powered system, with superconducting cables and motors for regional aircraft. They investigated the usage of liquid hydrogen to provide cryogenic cooling of superconductors. As there has not been a specific FC stack design for electrified aircraft, we propose exploring different configurations that can lead to the design of new stacks with higher power. Kasim et al [12] argues that a multi-stack system can not only achieve higher power demand, but also improve system reliability, though there is not enough research in the design and selection of multi-stack system analysis for aircraft propulsion applications to support this idea. Zhou et al [14] reviewed the multi-stack fuel cell system, including their architectures, performance and power management. They compared different association types for the multi-stack FCs with converters for electric vehicle industry. In this paper we extend this paper to other multi-stack configurations that are suitable for aviation and the design and implementation limitations at high voltage and high altitude due to weight constrains. Yan et al [15] investigated coordination methods for multi-stack fuel cell system to obtain optimal efficiency of two-stack and three-stack FC systems. This is achieved by identifying the optimal power setpoint of each stacks based on analytical solutions and try to tune the stack with an online control system. This method is feasible to be scaled for aviation if the analytical models can predict the behaviour of the stacks accurately for design and off design conditions. Cardenas et al [16] investigated the degraded mode operation of multi-stack fuel cell upon the loss of one of its stacks. Higher fuel consumption due to degradation of one cell due to reduction of efficiency was presented. This efficiency reduction was controlled by choosing which FC should be isolated in the case of degradation in one of the stacks.

Selection of system voltage for the electric powertrain has been studied with considering the trade offs between (a) weight, for example cable's weight (lower weight for higher voltages), and (b) at higher voltage and increasing altitude the occurrence of arcing increases as a result of decrease of the breakthrough voltage with decreasing surrounding air pressure, (c) reduction of conduction and Ohmic losses in power electronics and electric machines but with an increase of switching losses due to high voltage demand, (d) lack of high power density protection systems for high voltage distribution, and (e) the power stability and maintenance consideration. In a study presented in [17] a 6MW powertrain was modelled with a variable and constant distribution voltage. The optimum system voltage of the variable system voltage architecture was considered near the operating voltage of the electric motor (>1500V), while the optimum system voltage of the constant system voltage architecture was identified at higher voltages between 3000V and 4000V. In this paper we have selected a fixed 2000V DC-bus voltage as a system voltage and a variable DC-bus voltage up to 3080V. Both voltages are below the threshold studied in [18] for operating at a safe voltage at high altitude for regional aircraft.

In this paper several fuel cell configurations and their DC/DC converters are investigated to show their advantages and disadvantages for a propulsion system of regional aircraft. Firstly, the mission, the selected aircraft, and the propulsion system is presented, then the configurations are introduced and their contributions and challenges are discussed. The impact of converter selection on total system efficiency, system stability, failure scenarios and power losses, fuel consumption, and weight analysis for the selected missions is demonstrated.



**Fig. 1** An example of a propulsion system with FC stacks configured for different voltage and current outputs. Different DC/DC converter configurations are assessed to maintain the bus voltage at 2000V. These configurations are shown in Fig. 10. Eight permanent magnet synchronous machines were designed for 500kW power at rotational speed of 2000RPM.

Range	300 nmi	Payload	3500 kg
Calibrated Climb Speed	160 kts	Cruise Mach	0.46
Take-off Weight	17913 kg	Cruise Altitude	19000 ft

**Table 1** Flight mission specification

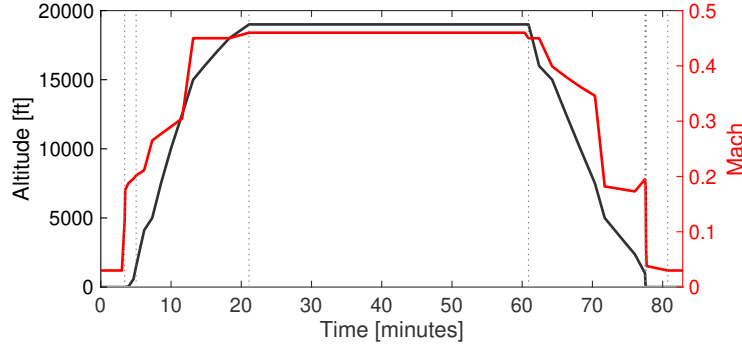
## II. Propulsion System

A 4MW fully electrified aircraft propulsion is selected. This propulsion system (Fig. 1) is modelled, to demonstrate the interactions between the FC stacks and the electrical configurations. In this system, two DC bus at 2000V are connected with bus ties. 2.4MW of power is required from each “side” of the propulsion system.

MIT’s Qmil/Qprop tool [19] was adopted for propeller design and propeller performance analysis. The produced propeller maps were integrated into our in-house model Hermes [20]: a flight path analysis platform in the Centre for Propulsion Engineering at Cranfield University. Table 1 shows the flight mission used in this analysis, and Fig. 2 shows the flight profile. FCvelocity®-HD6 Proton-Exchange Membrane Fuel Cell (PEMFC) stack operating points are chosen for this study. Table 2 presents FC parameters, and a detailed description of the model of the FC stack is presented in [21, 22].

An integrated framework within CHARM (Cranfield Hybrid-electric Aircraft Research Model) is used to model the mission performance of novel electrified propulsion systems. This model captures the coupled integration between components with the overall aircraft system, enable emissions and energy consumption evaluation, heat management system detailed design and performance analysis at off-design conditions, electric power system and component design and performance analysis, and capture the interactions between the sub-systems and aircraft level.

The proposed electrical architecture is modelled and analysed with the in-house E-HEART (Enabling-Hybrid Electric Aircraft Research and Technology) tool, which is part of CHARM. Electrical components and their interactions at component and their integration levels are studied within E-HEART. Different modelling approaches, from low fidelity fundamental equations to high fidelity models, such as finite element analysis for electric machines, and dynamic modelling of power electronics are included in E-HEART. For this study fundamental equations and finite element



**Fig. 2 Altitude and Mach variations for the duration of the flight.**

Symbol	Description	Value
$T$	Fuel cell operating temperature	330K
$N$	Fuel cell stack number	762
$z$	Moving electron number	2
$\tau$	Fuel cell dynamic time constant	0.1s
$\eta_C$	Compressor adiabatic efficiency	85%

**Table 2 PEMFC system specifications**

analysis have been employed for electric motor modelling. The integration of electric motor to the propeller have been explored in [23], where a similar architecture have been used. The design decisions for the electric motor and the propeller are explained to reduce noise and energy consumption.

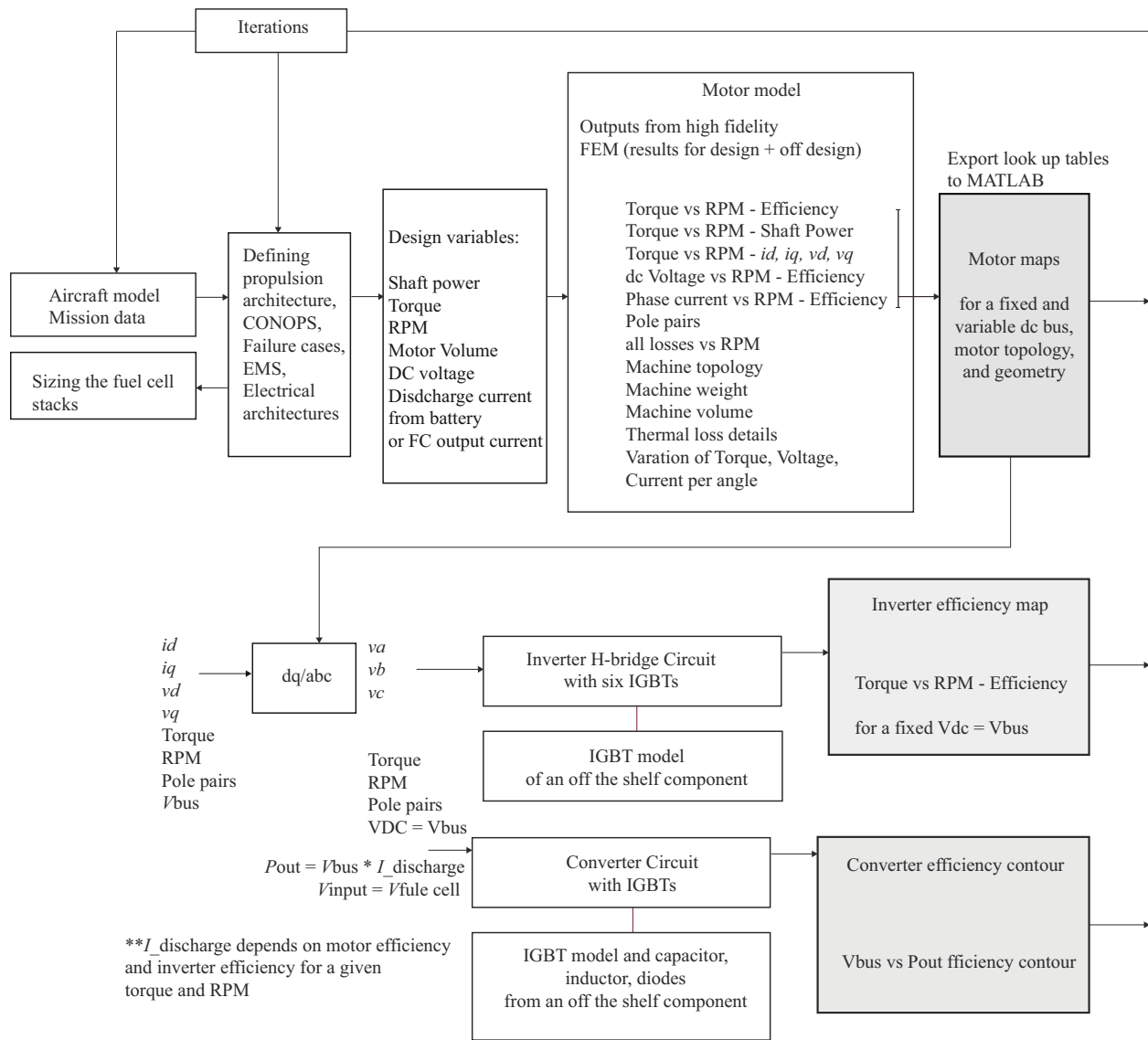
### A. Electric Power System Modelling

Fig. 3 describes the workflow to model the electric motor and the power converters and conduct a performance analysis. In this workflow the initial sizing of the motor is performed with the information received from the mission and the aircraft requirements, such as required power, motor rotational speed, volume, and thermal management requirements. Efficiency maps are obtained for a range of torque and rotational speed variations as well as distribution voltage and current requirements. These efficiency maps are then included in the performance modelling tool as a series of look up tables for the aircraft level studies presented in [24]. Interior Permanent Magnet (IPM) motor is chosen for this study. IPM motor was designed in ANSYS Motor-CAD and more details are provided in Table 3) and the efficiency map is shown in Fig. 4. Finite element analysis with ANSYS Motor-CAD is used to model the motor and the final results are shown as efficiency maps. The Direct Quadrature (D-Q) modelling of 3-Phase IPM machine is used to control and design an H-bridge motor inverter.

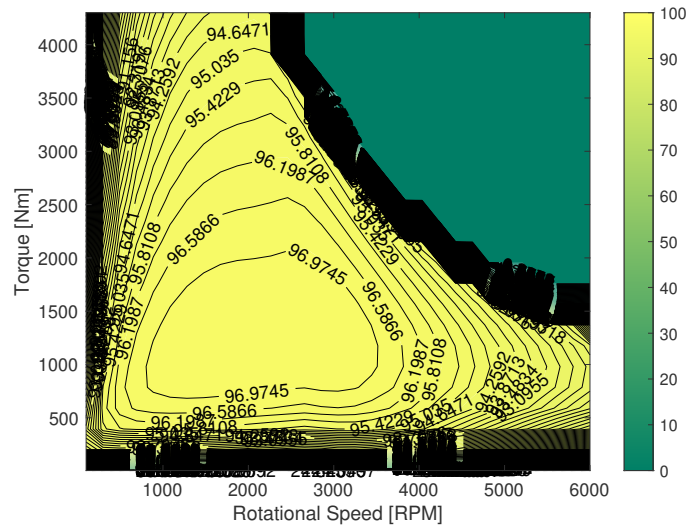
Power converters design and compliant with flight requirement directly affect its power densities. It is predicted that

Parameters	Values
Rotor diameter	317.5 (mm)
Stator diameter	450 (mm)
Number of poles	16
Airgap	1.25 (mm)
Stack length	370 (mm)
Number of slots	48

**Table 3 Electric machine design parameters**



**Fig. 3 Electric power system modelling workflow from multi-fidelity E-HEART tool.**



**Fig. 4 Electric motor efficiency map. This is for the case where BUS voltage was constant at 2000V.**

we might reach to 50kW/kg power density in the next decades with new silicon carbide, GAN devices, and emerging thermal management systems. In recent years, high voltage Silicon carbide (SiC) MOSFETs (>10-kV) have been developed due to their high blocking voltage, fast switching speed, and low switching loss [25]. Considering the high  $dv/dt$  (50–100 V/ns) in the switching transient, these power electronics require specific design considerations [25]. To study the design of the power converters and their integration as part of the electric power distribution we have considered the study based on current off the shelf components.

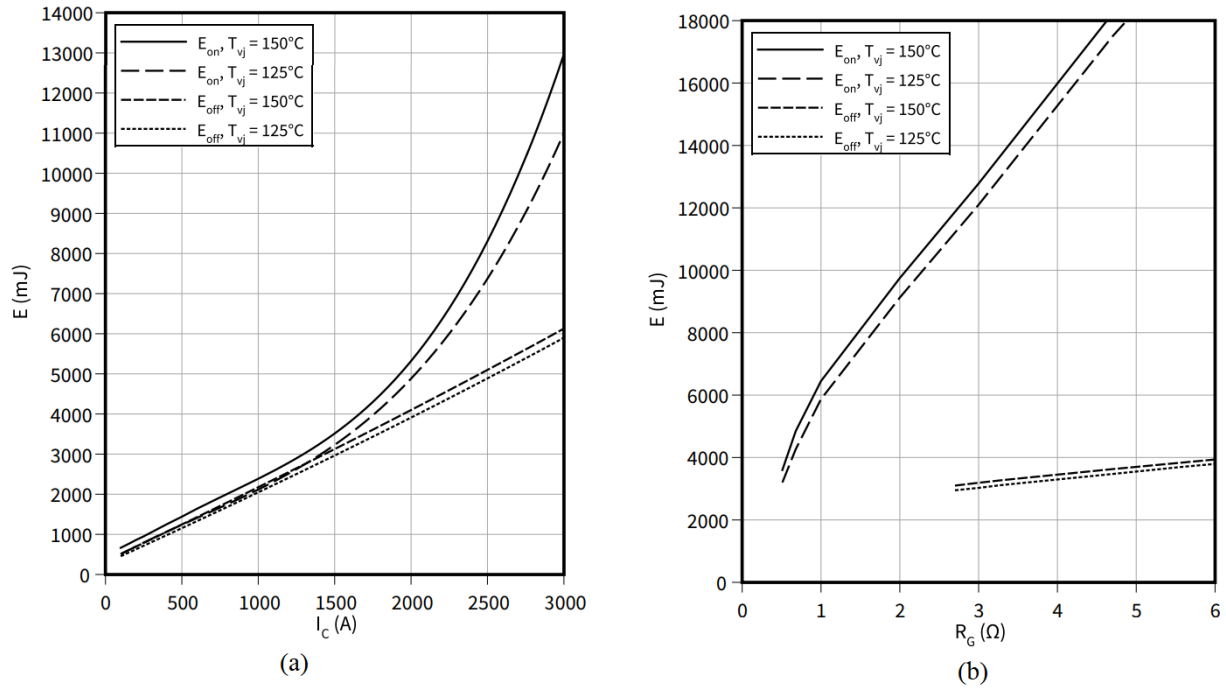
In design of power converters the switches are the major sources for power losses. Insulated gate bipolar transistors (IGBTs), thyristors, metal oxide semiconductor field effect transistors (MOSFETs) and are used for power converters. IGBTs with higher voltage and current design points but relatively lower switching frequencies are selected for this study. As the electrical motor selected for this study has a rotational speed less than 3000 rpm, the high frequency switching power converters are not considered. For the selected distribution design voltage in this study (2000V) and maximum power requirements for (4MW), we have selected an IGBT from infineon (model: FZ1500R33HL3) that has low switching losses (refer to Fig. 5) but also can work under voltage higher than 2000V when collector-emitter voltage  $V_{CES} = 3300V$ , Continuous DC collector current  $I_{CDC} = 1500A$  while keeping high voltage DC stability.

H-bridge inverter circuit is chosen Fig. 6 and efficiency is found for the variation of motor torque and rotational speed (as shown in Fig. 7. This efficiency map is obtained from a parametric study carried out from modelling the IGBTs from their characteristic shown in the datasheet partially shown in Fig. 5.

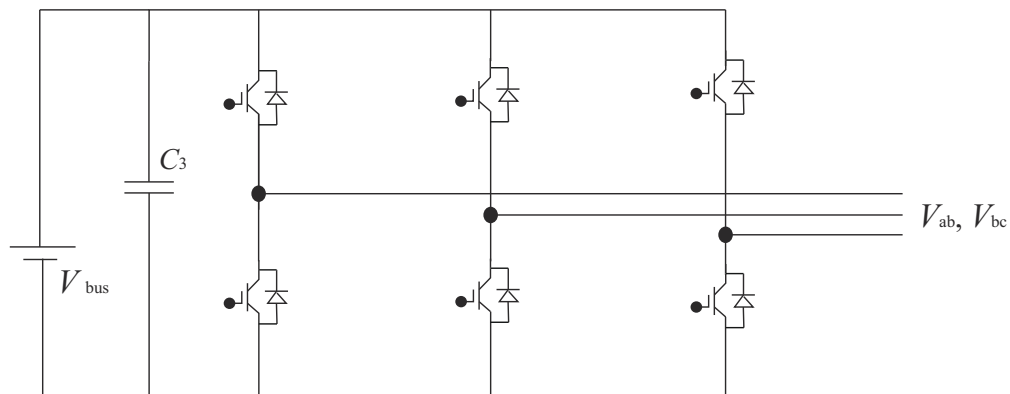
The non isolated bidirectional DC/DC converter was modelled using the FZ1500R33HL3 IGBT characteristics in a circuit shown in Fig. 8. The results of the modelling are shown as an efficiency contour for a given input voltage ( $V_i$ ) and power output  $P_o$  (or power demand). The efficiency contour for one of the cases presented in Section III is shown in Fig. 8.

### III. Multi-Stack fuel cell configurations

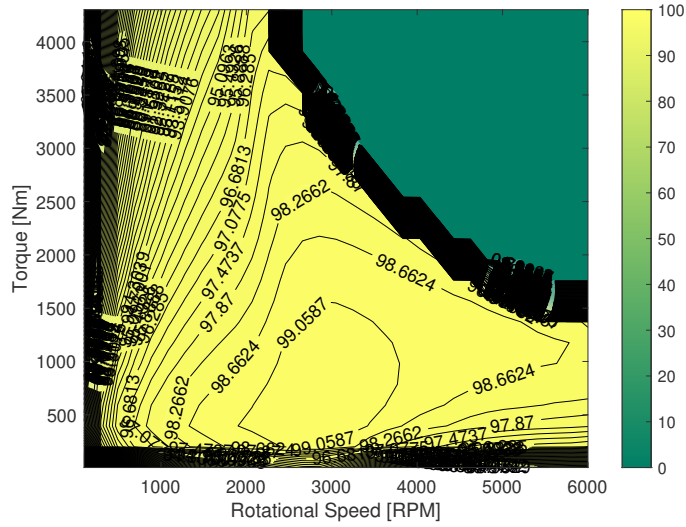
Possible multi-stack configurations with DC/DC converters are shown in Fig. 10. These configurations are assessed based on their FC stacks and system efficiencies as well as the electrical component efficiencies, power losses due to failure, voltage and current variation due to degradation, and their total weight. Table 4 summarises these analyses. The analysis and explanations in this paper does not consider the way the FC stack auxiliary system are connected, which they can also be in series or parallel but only consider the electrical connections. The influence of electrical connections on hydrogen and oxygen supply due to their specific configurations are not considered in this paper.



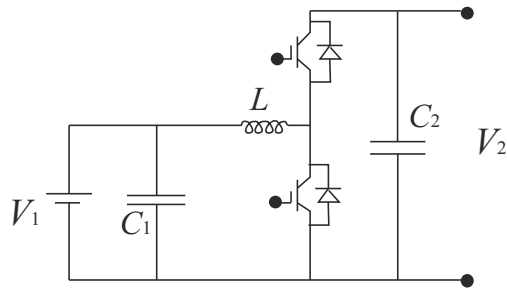
**Fig. 5** Switching losses per pulse as a function of the collector current and the gate resistance. (a) Switching losses for the IGBT-Inverter when  $V_{CE} = 1800V$ ,  $V_{GE} = \pm 15V$ . (b) Switching losses for the IGBT-Inverter when  $V_{CE} = 20V$ . Image is adopted from IGBT's (FZ1500R33HL3) data sheet from infineon.



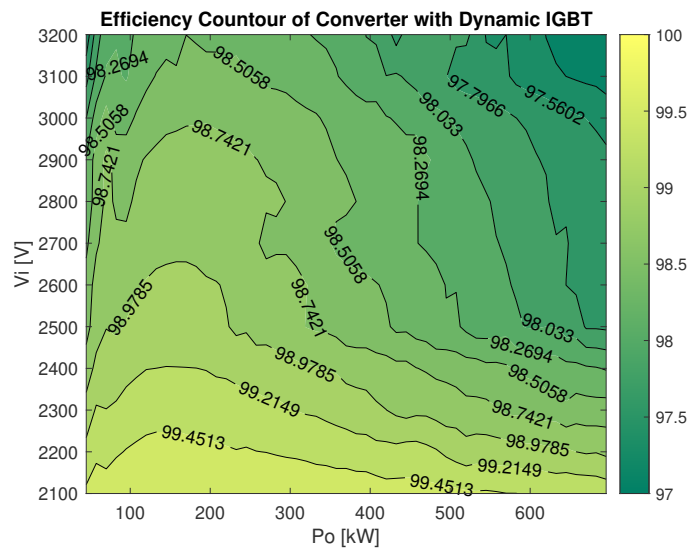
**Fig. 6** H-bridge Inverter for a three phase AC electric motor. The six IGBT3 modules indicated in this image are chosen based on the bus voltage and load current requirements. For this study FZ1500R33HL3 from infineon is chosen.



**Fig. 7** Inverter efficiency map is obtained for the selected inverter as shown in Fig. 6. This is for the case where the DC bus voltage was equal to 2000V.

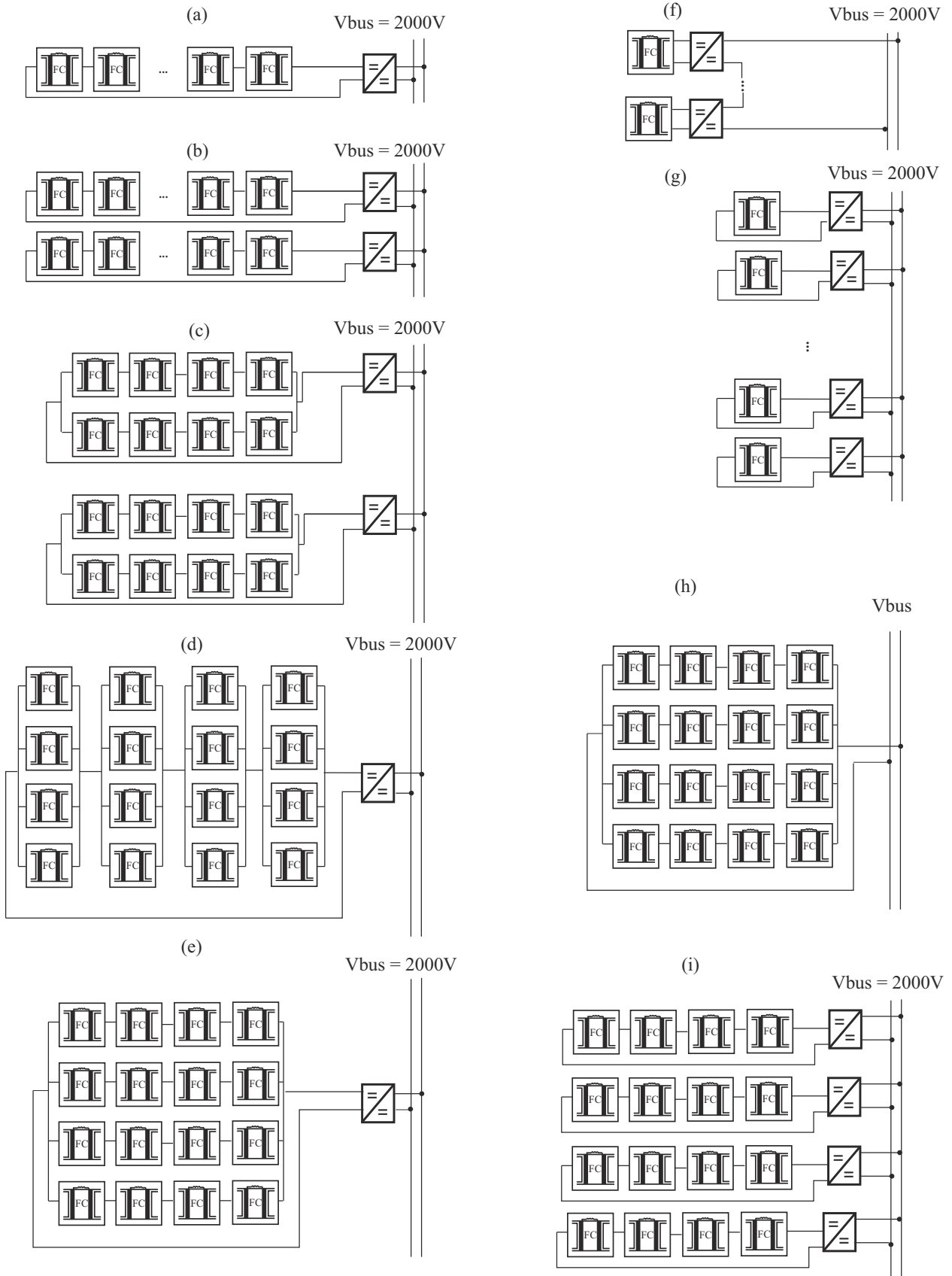


**Fig. 8** Non isolated bidirectional DC/DC converter.



**Fig. 9** Buck converter efficiency contour. This contour was obtained for case i presented in Section III.





**Fig. 10 Proposed electrical configurations for the FC stacks and DC/DC converters.**

Configurations	Description	Comparisons
(a - a)	Highest voltage achieved by adding 16 stacks in series. High voltage conversion to $V_{bus}$ .	Independent control of stack voltage is no longer achieved by one DC/DC converter. This system has lowest reliability if some of the FCs degrade or in the case of faults. This configuration at high voltage (>3000V [18]) is not recommended due to lack of protections and insulation designed for partial discharges at high altitude (at 40kft of altitude above sea level) that can be used without high weight penalties.
(b - b)	8 stacks can be connected in series.	Efficiency optimization with only few power electronics converters. This configuration at high voltage (>3000V [18]) is not recommended due to partial discharges at high altitude. However, if the design of cable insulation changes to provide higher power density, higher voltages can be recommended. This configuration is also more vulnerable to faults at high altitude, so it is not recommended because limiting the altitude capability of the aircraft will result in cruising at lower altitudes where the drag is higher and the fuel consumption will be higher.
(c - c)	8 stacks can be connected in series and 2 branches of them in parallel.	Efficiency optimization with only few power electronics converters. This configuration allows higher efficiency for the DC/DC converter due to smaller converter gain.
(d - d)	4 stacks connected in parallel and then in series.	This configuration provide higher current and has 1 converter for voltage control which can be a single failure point if the converter fails and half of the total power from the FCs is lost. This configuration is more reliable than configuration (e) when one FC degrades [21]
(e - e)	4 stacks connected in series and then in parallel.	Converter for this configurations could be designed but also the rest of the system could be designed without a converter like case (h).
(f - f)	16 stacks with individual DC/DC converters connected in series then to the bus	Independent control of voltage level is enabled as well as insulation when operating in degraded mode. Accurate control of the converters are required.
(g - g)	16 stacks with individual DC/DC converters with controllers are connected to the bus	Several degrees of freedom for energy management, control of power drop as as result of degradation with individual converters, and faulty mode operation are possible. Voltage conversion rate is the highest if $V_{bus} > V_{st}$ , efficiency of the converter and its power density is the lowest. Configuration (g-g) is heavier so the maximum payload will be reduced and the energy consumption will be higher when performing the same mission, but it offers better operability in degraded and faulty mode. Degradation tolerance of this configuration may prolong time-on-wing.
(h - h)	4 stacks connected in series and then in parallel.	This configuration provide lower current to the bus than case (g) and does not have a converter for voltage control. The electric machine and the inverter have to be designed to support the voltage range and consequently the power requirement during each phase of the mission.
(i - i)	4 stacks connected in series.	This configuration is the most reliable system with higher efficiency for the converter in comparison to case (d) and (e) due to reduction in current. But four converters add higher weight compare to case (h), but instead provide constant voltage for the bus.

Configurations	Description	Comparisons
(g - i)	Two different configurations for each buses.	Since two buses are connected for power sharing in the case of failure a mixture of more efficient or highly reliable but heavier configurations can be joint together. For example configuration (g) is the most reliable but the heaviest and configuration (i) is the most efficient

**Table 4** Assessment of electrical configurations for the FC stacks and DC/DC converters. Where configurations are connected, for example a-a, means the two 2000V bus are connected with a bus ties for power sharing.

Despite the same output propulsion power, the selection of FC configurations and architecture has an impact on system weight and loss of power due to failure. A retrofit approach is adopted in this study which means that the FC propulsion system is implemented on an existing aircraft design. For this reason, the Maximum Take-Off Weight (MTOW) is a constraint, consequently the maximum take-off power is fixed for all the investigated configurations.

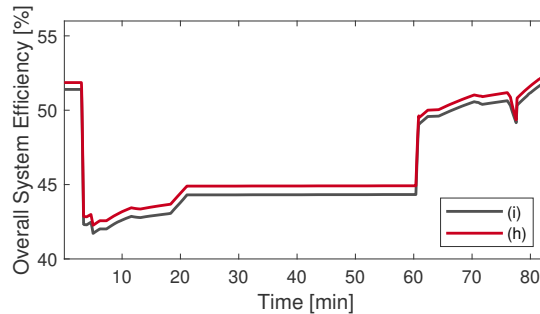
The heavier FC and converter configurations increase the Operating Empty Weight (OEW) of the aircraft, therefore, the weight allowance to be shared between payload and range will be reduced, since the MTOW is fixed. Due to the low hydrogen consumption of the FC, 500-1000kg of hydrogen is usually sufficient to cover the ranges of a regional turboprop aircraft. Consequently, the higher FC system weight will limit the payload, if we assume a constant tank capacity.

Furthermore, when comparing the different FC configurations, the heavier FC configurations (hence heavier OEW), will have increased aircraft weight when performing the exact same mission (payload, range, altitude), which means that the power requirement and fuel consumption will be higher at cruise.

#### A. Configurations (h) and (i)

Comparing cases (h) and (i) for total system efficiency shows that, removing the converters increase the total system efficiency (Fig. 11) by a small percentage. This is due to added benefit on removing the converter efficiency, even though the inverter efficiency in the case of variable voltage (case h) is slightly lower than when bus voltage is fixed (Fig. 12). This is mainly due to the characteristics of the selected IGBTs and their losses at high voltage.

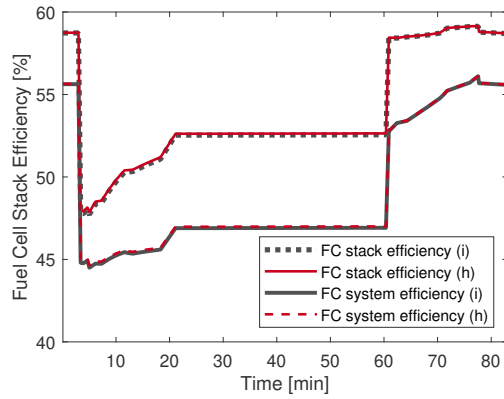
The efficiency of the fuel cell stacks and the system is not affected by the bus voltage variations, and for both case i and h the efficiency has not changed (Fig. 12a). Motor efficiency is similar for the case with constant and variable bus voltage (Fig. 12b) this is due to careful selection of motor design parameters to support variable voltage requirements. Voltage and current variations are shown in Fig. 13. More investigations are needed in terms of the winding insulation at 3080V (the highest system voltage for case h) and protections due to arching.



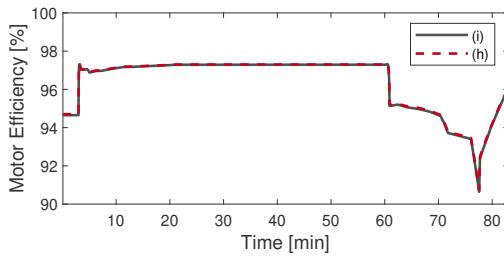
**Fig. 11** Overall system efficiency for cases i and h.

## IV. Conclusion

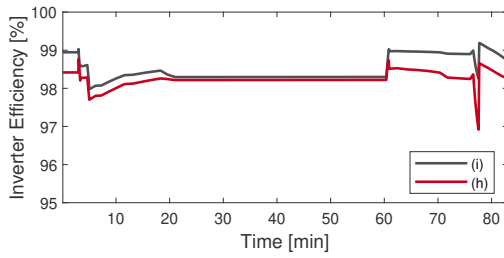
This paper presents a trade off study between different multi-stack FC configurations, DC/DC converter topologies and their contributions, and their impact on the mission requirements. For a 4MW electrified propulsion with PEMFC, several electrical configurations were assessed qualitatively based on their efficiency performance at high voltage, the



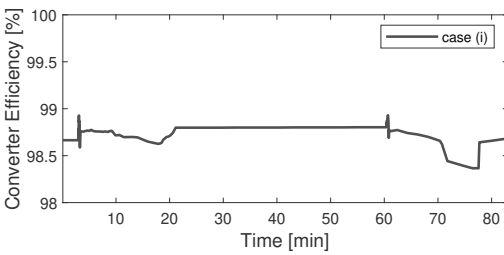
(a)



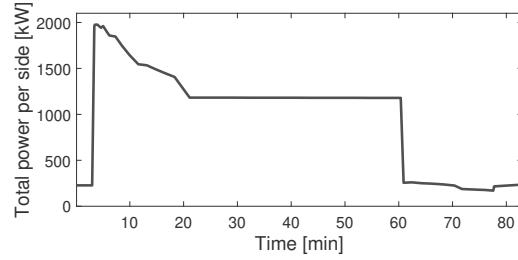
(b)



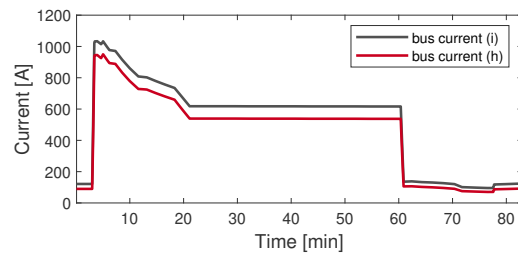
(c)



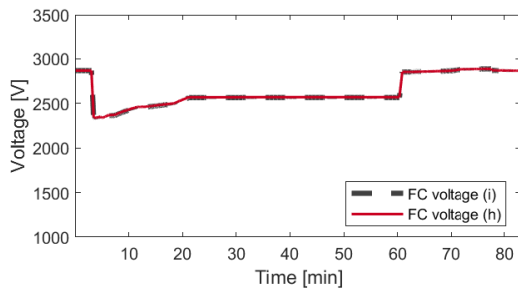
(d)



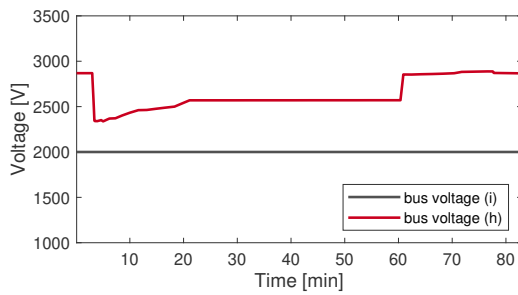
(a)



(b)



(c)



(d)

**Fig. 13 Total power, voltage, and current required**

**for the duration of the mission per bus side.**  
**Fig. 12 Efficiencies of the proposed propulsion system components for the duration of the flight.**

appropriate power electronics for each configurations, and power losses due to FC degradation and failure cases. Aircraft performance parameters, FC system efficiency and overall propulsion efficiency over flight time for two configurations were shown. The system without a converter and with variable bus voltage showed slightly higher overall efficiency. The main differences between the cases presented are on total system weight and design of electric power distribution protection in the case of failure. The comparisons of different configurations shown here were based on electric powertrain redundancy considerations. The increase use of power converters in powertrain design can be used as a way of protection against electrical faults and loss of complete power. The effect of different electric power distribution protection have not been studied in this study and needs to be investigated for future studies.

## Acknowledgments

This project has received funding from the European Union's Horizon 2020 Research and Innovation Programme under Grant Agreement No 875551.

## References

- [1] Huete, J., Nalianda, D., Zaghari, B., and Pilidis, P., "A Strategy to Decarbonize Civil Aviation: A phased innovation approach to hydrogen technologies," *IEEE Electrification Magazine*, Vol. 10, No. 2, 2022, pp. 27–33.
- [2] Spinelli, A., Enalou, H. B., Zaghari, B., Kipouros, T., and Laskaridis, P., "Application of Probabilistic Set-Based Design Exploration on the Energy Management of a Hybrid-Electric Aircraft," *Aerospace*, Vol. 9, No. 3, 2022, p. 147. <https://doi.org/10.3390/aerospace9030147>.
- [3] Chen, J., and Song, Q., "A decentralized energy management strategy for a fuel cell/supercapacitor-based auxiliary power unit of a more electric aircraft," *IEEE transactions on industrial electronics*, Vol. 66, No. 7, 2018, pp. 5736–5747.
- [4] website [online], H., "H2FLY," <https://fuelcellworks.com/news/new-dlr-hy4-the-first-hydrogen-powered-aircraft-debuts-at-stuttgart-airport/>, 2022. Accessed: 2022-06-10.
- [5] "DLR," [https://www.dlr.de/content/en/articles/news/2021/01/20210121\\_balis-project-funding.html](https://www.dlr.de/content/en/articles/news/2021/01/20210121_balis-project-funding.html), 2022. Accessed: 2022-06-10.
- [6] "ZeroAvia," <https://www.zeroavia.com/>, 2022. Accessed: 2022-06-10.
- [7] Bradley, M., "Identification and Descriptions of Fuel Cell Architectures for Aircraft Applications," *2022 IEEE Transportation Electrification Conference & Expo (ITEC+)*, IEEE/AIAA, 2022, p. x.
- [8] Nøland, J. K., "Hydrogen Electric Airplanes: A disruptive technological path to clean up the aviation sector," *IEEE Electrification Magazine*, Vol. 9, No. 1, 2021, pp. 92–102.
- [9] "PRODUCT DATA SHEET: High Performance Fuel Cell Stack," [https://www.ballard.com/docs/default-source/spec-sheets/fcgen-hps.pdf?sfvrsn=704ddd80\\_4](https://www.ballard.com/docs/default-source/spec-sheets/fcgen-hps.pdf?sfvrsn=704ddd80_4), 2022. Accessed: 2022-06-10.
- [10] Zeng, G., Zhu, Y., Liu, C., and Gao, X., "Modeling and Feasibility Analysis of Hydrogen Fuel Cells Powered All Electric Aircrafts," *2021 IEEE Sustainable Power and Energy Conference (iSPEC)*, IEEE, 2021, pp. 3605–3611.
- [11] Kadyk, T., Winnefeld, C., Hanke-Rauschenbach, R., and Krewer, U., "Analysis and design of fuel cell systems for aviation," *Energies*, Vol. 11, No. 2, 2018, p. 375.
- [12] Kasim, A. A., Marek, E., et al., "Performance and failure analysis of a retrofitted Cessna aircraft with a Fuel Cell Power System fuelled with liquid hydrogen," *Journal of Power Sources*, Vol. 521, 2022, p. 230987.
- [13] Hartmann, C., Nøland, J. K., Nilssen, R., and Møllerud, R., "Dual Use of Liquid Hydrogen in a Next-Generation PEMFC-Powered Regional Aircraft with Superconducting Propulsion," *IEEE Transactions on Transportation Electrification*, 2022.
- [14] Zhou, S., Fan, L., Zhang, G., Gao, J., Lu, Y., Zhao, P., Wen, C., Shi, L., and Hu, Z., "A review on proton exchange membrane multi-stack fuel cell systems: architecture, performance, and power management," *Applied Energy*, Vol. 310, 2022, p. 118555.
- [15] Yan, Y., Li, Q., Chen, W., Huang, W., Liu, J., and Liu, J., "Online Control and Power Coordination Method for Multistack Fuel Cells System Based on Optimal Power Allocation," *IEEE Transactions on Industrial Electronics*, Vol. 68, No. 9, 2020, pp. 8158–8168.

- [16] Marx, N., Toquica Cárdenas, D. C., Boulon, L., Gustin, F., and Hissel, D., “Degraded mode operation of multi-stack fuel cell systems,” *IET Electrical Systems in Transportation*, Vol. 6, No. 1, 2016, pp. 3–11.
- [17] Vratny, P. C., Kuhn, H., and Hornung, M., “Influences of voltage variations on electric power architectures for hybrid electric aircraft,” *CEAS Aeronautical Journal*, Vol. 8, No. 1, 2017, pp. 31–43.
- [18] Recalde, A., Bozhko, S., Atkin, J., and Sumsurroah, S., “Optimal Voltage for More Electric Aircraft direct current cabling system,” *2021 IEEE Transportation Electrification Conference & Expo (ITEC)*, IEEE, 2021, pp. 106–111.
- [19] “QMIL/QPROP,” <https://web.mit.edu/drela/Public/web/qprop/>, 2007. Accessed: 2022-06-10.
- [20] Laskaridis, P., Pilidis, P., and Kotsiopoulos, P., “An integrated engine-aircraft performance platform for assessing new technologies in aeronautics,” *International Society for Air-Breathing Engines Conference*, 2005.
- [21] Zhou, T., Enalou, H. B., Pontika, E., Zaghari, B., and Laskaridis, P., “Minimising the effect of degradation of fuel cell stacks on an integrated propulsion architecture for an electrified aircraft,” *ITEC+ 2022*, IEEE, 2022.
- [22] Tremblay, O., Dessaint, L.-A., et al., “A generic fuel cell model for the simulation of fuel cell vehicles,” *2009 IEEE vehicle power and propulsion conference*, IEEE, 2009, pp. 1722–1729.
- [23] Kiran, A., Zaghari, B., Sinnige, T., Pontika, E., Balaghi Enalou, H., Kipouros, T., and Laskaridis, P., “The Impact of Electric Machine and Propeller Coupling Design on Electrified Aircraft Noise and Performance,” *AIAA SciTech*, 2023.
- [24] Pontika, E., Zaghari, B., Zhou, T., Balaghi Enalou, H., and Laskaridis, P., “An Integrated Mission Performance Analysis of Novel Propulsion Systems: Analysis of a Fuel Cell Regional Aircraft Retrofit,” *AIAA SciTech*, 2023.
- [25] Anurag, A., Acharya, S., Prabowo, Y., Gohil, G., and Bhattacharya, S., “Design considerations and development of an innovative gate driver for medium-voltage power devices with high  $dv/dt$ ,” *IEEE Transactions on Power Electronics*, Vol. 34, No. 6, 2018, pp. 5256–5267.

2023-01-19

# The impact of multi-stack fuel cell configurations on electrical architecture for a zero emission regional aircraft

Zaghari, Bahareh

AIAA

---

Zaghari B, Zhou T, Enalou HB, et al., (2023) The impact of multi-stack fuel cell configurations on electrical architecture for a zero emission regional aircraft. In: AIAA SciTech Forum 2023, 23-27 January 2023, National Harbor, Maryland, USA, Paper number AIAA 2023-1593

<https://doi.org/10.2514/6.2023-1593>

*Downloaded from Cranfield Library Services E-Repository*