

# A Fault Tolerant Multi-Sensor Fusion Navigation System for Drone in Urban Environment

Tarafder Elmi Tabassum, Ivan Petrunin, Zeeshan Rana

Cranfield University  
Bedford, United Kingdom  
email: tarafder-elmi.tabassum@cranfield.ac.uk

Cranfield University  
Bedford, United Kingdom  
email: i.petrunin@cranfield.ac.uk

Cranfield University  
Bedford, United Kingdom  
email: zeeshan.rana@cranfield.ac.uk

**Abstract:** *Precise positioning becomes an attractive research area to enhance last-mile delivery with drones. However, the reliability of precise positioning is significantly degraded in GNSS-denied environments such as urban canyons. In this case, the excellent performance of Visual Inertial Odometry (VIO) in local pose estimation makes visual navigation technology more feasible for researchers. However, the accuracy and robustness of VIO degrade in faulted conditions. This paper presents a fault-tolerant multi-sensor fusion navigation system for drones in urban environments. We first performed Failure Mode and Effect Analysis (FMEA) in the VIO system to identify potential failure mode, which is feature extraction errors. Then, an integrated, loosely coupled EKF-based VIO system is proposed for our GNSS/VINS/LIO reference system to mitigate visual and IMU faults. The performance of the proposed method was validated by a synthetic dataset created using MATLAB, and it has shown improved robustness over Visual odometry and state-of-art VINS systems.*

## 1. Introduction

Recently, drone has been widely used for various applications such as drone delivery which requires them to fly close to walls or structures in urban environments that imply a higher risk of collision and thus require precise positioning. The Global Navigation Satellite System (GNSS) has been the dominant approach for such environments. Still, the accuracy of such systems degrades in the presence of signal blockage, GNSS signal denial, multipath effect, and limited satellite visibility. However, precise positioning in this scenario can be achieved if some additional positioning information is available. The additional information could come from the Visual sensor, Lidar, and Inertial Measurement Unit (IMU). Therefore, it has been proposed to integrate the GNSS/VINS/LIO system that provides robust and accurate information in urban environments. However, integrating multiple sensors can have the possibility of faults, noise, or sensor failure. Thus, identifying potential faults and threats is essential for the precise positioning of the GNSS/VINS/LIO reference system should be considered.

With the development of computer vision technology, visual navigation systems are more likely to be adopted by researchers to estimate robust positions in the GNSS-degraded environment. Visual odometry is reliable and accurate for estimating the pose of robots, ariel drones, rovers, and autonomous driving [4]. The accuracy and robustness of VO degrade if observed features from the camera are insufficient [14]. IMU sensor has been integrated with VO that forms

Visual Inertial Odometry (VIO) system to improve the performance. IMU can provide high-frequency motion information that modifies the estimation performance of VO [13]. Hence, Visual Inertial Odometry can be the solution to various challenges like vital illumination changes, rapid motion, and limited field of view [15].

A multiple-sensor fusion EKF-based framework was proposed, which eliminated GNSS and IMU errors and showed that the performance was improved in the presence of multiple faults [17]. An integrated EKF-based vision-aided navigation system provided UAVs with drift-free velocity and attitude estimation [16]. They focused on eliminating IMU bias faults by adding visual sensors but still, results showed estimated position drifted slowly. An adaptive Kalman filter-based fault-tolerant Visual-Inertial Navigation (VIO) system was proposed in a hostile environment that discussed feature extraction error and carried out the experiment in an open sky environment resulting in a positioning accuracy of 1.89m [12]. Zhang C [15] proposed another approach based on key-framed Visual Inertial Odometry for the indoor environment and achieved relatively accurate positioning with the framework.

Another robust MSCKF-based VIO framework was proposed to estimate the precision and robustness of the system in the presence of dynamic objects and illumination variance [14]. The system could reject uncertain features in the correction system of EKF. The validation process was carried out in an indoor lab using EuRoc public datasets [14], resulting in a 0.56m position error.

To further improve positioning in challenging urban environments from reference multi-sensor systems focused on eliminating GNSS faults, we have carried out research on achieving precise positioning with degraded GNSS performance and mitigating visual sensor and IMU faults.

The main contribution of the paper is proposing a new approach for a fault-tolerant multi-sensor navigation system for robust positioning in urban environments. For this purpose, failure mode and effect analysis (FMEA) has been conducted on the proposed VIO system for the GNSS/VINS/LIO system to extract the high risk of failures in the system: feature extraction error. These failure modes result in positioning errors in the reference system. The reference system used Kalman Filter for fusion due to the linear structure of observation measurements, which struggles to mitigate errors in visual sensors. We have used Extended Kalman Filter (EKF) based fusion approach for combining IMU measurements with Visual information. Our EKF-based fusion algorithm aims to maintain several camera poses in the state vector and use visual measurements from the same features of multiple camera views to update states in the presence of either VINS or GNSS.

Multi-Sensor positioning experiments are carried out to verify the effect of our proposed solution for precise positioning in the MATLAB simulated environment. We have compared the results with our previous results, showing an increment in error reduction in the VIO subsystem. Thus, our proposed fault-tolerant system improves the robustness of positioning data.

## **2. Failure Mode and Effect Analysis**

To improve precise positioning concerning expected high robustness, it is necessary to have a good knowledge of all potential threats and faults. The potential faults that need to be considered for enhancing the performance of the multi-sensor fusion navigation system are investigated with the fault analysis method: Failure Mode and Effect Analysis (FMEA). To achieve precise positioning for the GNSS/VIO/LIO system, the failure modes of the reference system can be categorised as follows-

- GNSS failure modes
- VIO failure modes
- LIO failure modes

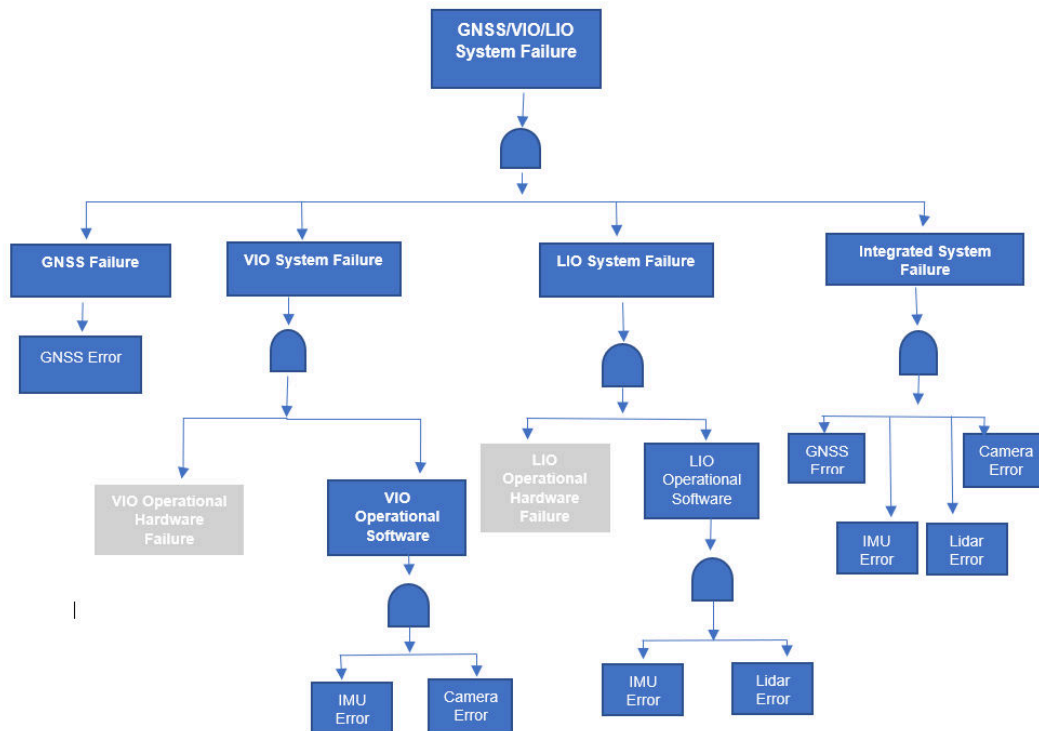

Figure 1. Example of fault tree for GNSS/VIO/LIO system failures

One of the most popular ways of analysing risk that breaks down failure events into lower-level events to allocate risks is fault tree analysis (FTA) [1]. We have conducted FTA based FMEA analysis shown in Figure 1 for the reference system. The FMEA analysis for the reference system helps us to identify high-risk failures in the system. In the reference system, the visual part has a high risk of failure due to GNSS unreliability and navigation scenario in Urban Canyon. Therefore, in this paper, we focused on improving visual positioning with degraded GNSS performance by identifying nominal faults in visual components and enhancing the robustness of the reference system to identify high-risk system failure modes with their characteristics, causes, impacts, and mitigation methods [1]. The analysis of failure modes not only considers failures related to the system separately but also the integrated architecture. Accordingly, in order to identify faults in Visual-Inertial Odometry (VIO) that result in visual measurement error, we have categorised the failure modes associated with the visual sensor, IMU sensor and integrated VIO system as follows-

- Visual sensor failure mode
- IMU sensor failure modes
- Integrated VIO system failure modes

Failure in the visual-inertial odometry system could occur at different levels, such as light intensity and the number of feature points tracked, leading to positioning error increment. Table 1 presents a summary of visual sensor failure modes based on existing literature [3], augmented with new failure modes identified in this paper. Failure modes of Inertial Measurement Units (IMU) are also considered to design fault-tolerant multi-sensor fusion navigation systems for drones in urban environments.

Table 1 Complied failure modes of Visual Navigation System

Failure Mode	Error Type	Effect
Feature location domain error	Reprojection error	Binary association faults may occur in the landmark location.
Feature extraction error	Stochastic geometric error	Given a rise in uncertainty for the extracted corner location of the image
Feature association error	Geometric error	Positioning results contain significant bias during feature extraction.
Feature domain noise	Position error and attitude error	Affect geometric measurements for camera position
Intensity domain biases	Data association error	Affect visual positioning performance such as overexposure
Feature domain biases	Data association error and feature mismatch	Results fault in landmark locations that cause significant navigation errors and could place the vehicle in a hazardous position
Position domain covariance error	Photometric noise	Correlated errors in positioning across multiple landmarks
Position domain nominal error	Photometric error	Results in error in the measurements between the sensor and the rendered image features
Liniarization error	Significant bias and data association error	Convergence failure in nonlinear optimisation
Outlier error	Position error	The applied feature is not at the expected position.
Motion blur	Photometric noise	Cause sensor thermal noise and lens blur

Table 2 represents the specific IMU failure modes extracted from existing literature [2] that has been considered in this research.

Table 2 Complied failure modes of IMU sensor

Failure Modes	Effect
Random walk in Gyroscope	An error in the gyroscope by taking random steps from sample to sample can result in a position error in the navigation system.
Random walk in Accelerometer	Error occurred in accelerometer by front end signal processing.
Bias in Accelerometer	Constant bias error in the accelerometer causes error in a position that grows over time.
Bias in Gyroscope	Cause angle drift in the system
Calibration error	Error occurs during the calibration process, which results in additional drift in the system.

Analysing failure modes for integrated Visual-inertial Odometry can help identify high-risk faults for positioning error, develop the respected fault model, and prevent possible failures. There are many works published on fault analysis on GNSS [1] [2] [9], Visual or Inertial positioning, but failure modes in precise visual positioning are seldom discussed. For visual positioning, error sources are high during the feature extraction step, resulting in positioning

errors in the whole system [4]. Hence, we focus on mitigating positioning errors in feature extraction failure mode and improving the Visual Inertial Odometry performance.

### **3. Proposed Fault-Tolerant Navigation Solution**

As we discussed in the previous section, there are error sources in every domain in the visual positioning process identified through FMEA analysis. For visual navigation, it is necessary to extract geometric information from images. Generally, intensity values in the image are noisy due to various error sources, where these photometric noises represent the raw error in the intensity values of the image. As we aim to mitigate visual positioning errors that occur by feature association error failure mode in Visual-Inertial Odometry, error propagation in the depth estimation must be considered while designing the process model of the system. In feature-based Visual Odometry, the procedure starts with extracting more geometric information from raw images for positioning. In the beginning, geometric information was hidden in raw measurement images that contained a considerable amount of the information provided by intensity values of image parameters (pixels). Error during feature extraction can be represented as a 2D geometric error in feature location that causes feature location faults in the system. While matching 2D feature locations to 3D coordinates, binary association faults or feature mismatch errors can occur. Accordingly, IMU sensor failure has also been considered as we conduct FMEA analysis. IMU measurements are corrupted by error sources discussed in the previous section. IMU failure mode, such as random walk in the accelerometer, is highly influenced and causes interruptions in the navigation process. In literature, FMEA analysis for designing fault-tolerant visual navigation system is hardly discussed. In this paper, an EKF-based fault-tolerant Visual Inertial Odometry has been designed based on FMEA analysis mitigating positioning error under mentioned visual and IMU fault conditions. To reduce output positioning error under significant faults (visual and inertial), a new fault has been added to the visual odometry state estimation model to represent feature mismatch error in the propagation system.

#### ***3.1 Visual Inertial odometry measurement***

Visual Odometry aims to estimate the motion of the drone from the camera image and find the projections of spatial points or correspondence of pixels in consecutive frames [4]. In this paper, the feature-point-based VO method has been considered as we propose to reduce feature association and feature location failure modes. The feature-based method is based on local features of an image considered to be its feature points [4]. The implementation of stereo VO based feature based method includes the following steps:

- Feature extraction
- Feature matching
- Depth estimation
- RANSAC
- Motion estimation

In the feature extraction stage, ORB feature points are chosen due to their real-time capability and reliability [11]. The feature-matching process named RANSAC has been carried out according to Fu [4]. Afterwards, feature mismatch 3D error point has been added with the motion estimation model of VO:

$$\begin{bmatrix} \Delta X_n \\ \Delta Y_n \\ \Delta Z_n \end{bmatrix} = \begin{bmatrix} X_n \\ Y_n \\ Z_n \end{bmatrix} - R \begin{bmatrix} X_{n-1} \\ Y_{n-1} \\ Z_{n-1} \end{bmatrix} + t \quad (1)$$

Here, X,Y, Z are 3D points in the coordinate,  $\Delta X, \Delta Y, \Delta Z$  are the measurement error, n is the current frame and n-1 is the previous frame. Additionally, we consider the feature mismatch error as fault, so camera transition vector  $t$  and rotation matrix  $R$  have been taken from the integrated stereo camera model in MATLAB.

### 3.2 Integrated System

The designed integrated system is based on the Extended Kalman Filter method [9] for better convergence in the estimation. Predicted state estimate  $\hat{x}_{n|n-1}$ , filtered state covariance  $P_{n|n}$ , and predicted state covariance  $P_{n+1|n}$  are estimated by using equations stated on [9]. The rest of the steps are the same, except that we estimated visual measurement instead of GNSS measurement. The additional feature extraction fault represented by equation (1) is added to the visual odometry state estimation step [9] that has been corrected with estimating  $P_{n|n}$ .

Figure 2 shows the architecture of the proposed VIO integrated system, and the measurements come from different parts.

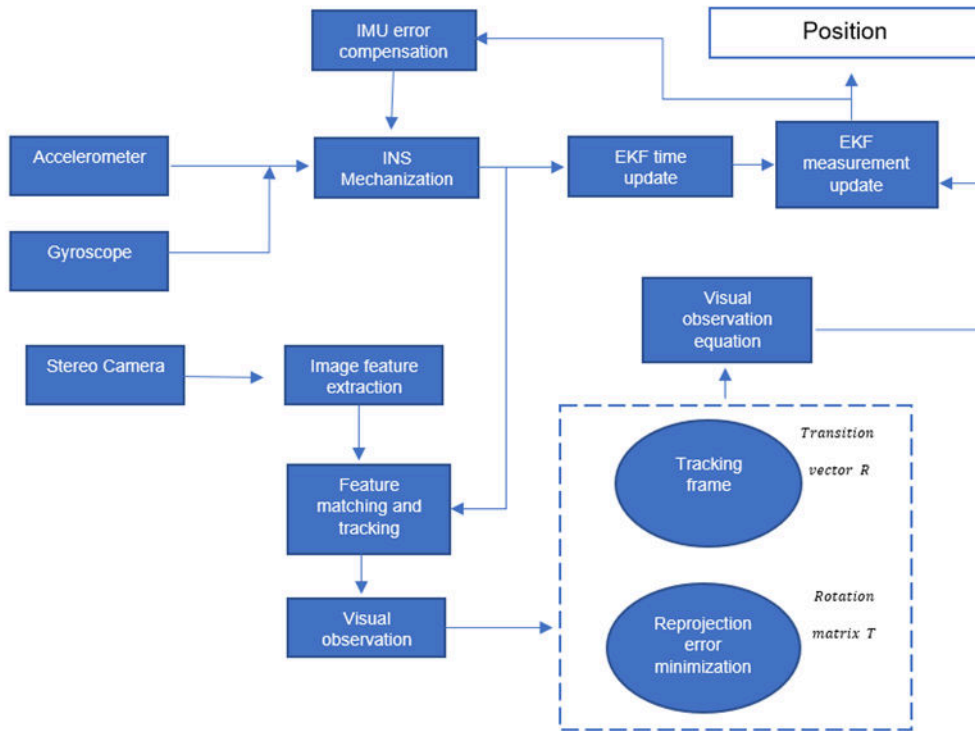

Figure 2. Integrated fault-tolerant Visual-Inertial Odometry system

## 4. Simulation and Analysis

In this section, we verify the performance of the proposed solution through simulation experiments and compare them with different navigation scenarios.

#### 4.1 Simulation setup:

A Quadrotor-type UAV virtual simulation environment has been created using MATLAB 2022 Simulink to carry out the experiment shown in Figure 3. In the 3D simulated environment, it is feasible to model the UAV prototype and specify the unique mission with prebuild reference GNSS/VINS/LIO system incorporation with required sensors like GNSS, IMU, camera, lidar. UAV toolbox has been used to create the virtual environment, which features a photorealistic environment for UAV flight by rendering the urban environment scenario representing urban canyon. Therefore, we have used the UAV delivery package simulation prototype [5] to generate the synthetic dataset. Figure 3 displays an example of a virtualised simulation along with single camera output.

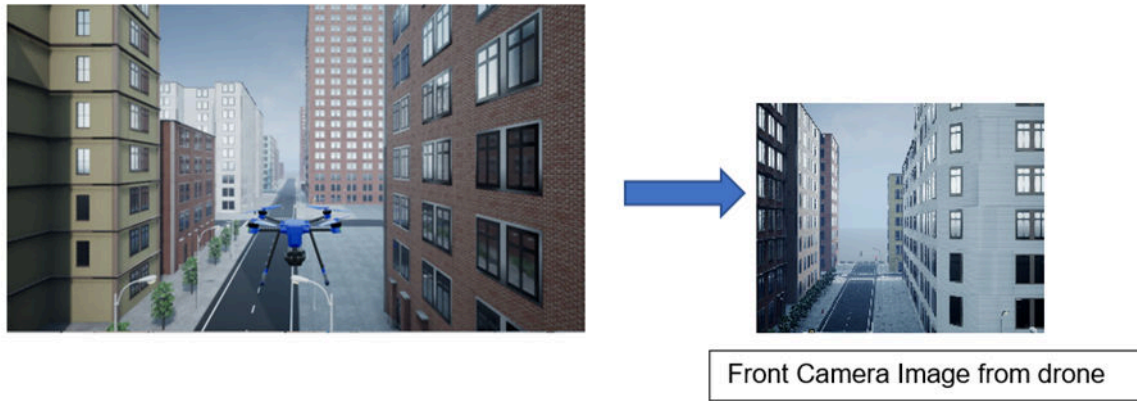

Figure 4. UAV scenario simulation environment running in MATLAB representing urban canyon that has been virtualised as a drone delivery scenario in US city

The simulation model has been implemented with the help of Simulink, where UAV states are shown in Figure 4, where input UAV state has been created from prebuild UAV toolbox model named ‘UAV package delivery’ [6] structure. The ground truth block has been taken from UAV UAV state through a simple bus signal. Additionally, the other blocks ‘Camera Model’, ‘IMU’ are created to generate a dataset to test our proposed fault-tolerate multi-sensor system. We have created a stereo camera model by combining two single ‘front-facing camera’ in the model [7]. Here, Table 3 represents the parameters of the IMU sensor.

Table 3 Parameters of IMU

Inertial Sensor	Frequency	Error Term	Values
Gyroscope	100Hz	Constant drift	$2^\circ/h$
		Random walk	$0.053^\circ/\sqrt{h}$
Accelerometer		Constant bias	$0.01^\circ/h$
		Random walk	Not considered

Different abrupt faults have been added to Visual odometry and IMU measurement to analyse the proposed system's performance. Visual Odometry carries bias in geometric measurement while extracting information during feature matching. For this reason, 3D point error equation

(1) has been added to the visual odometry position estimation step [8]. The signal of IMU sensor carries accelerometer random walk peak-peak noise of  $2 \text{ m/s}^2$ .

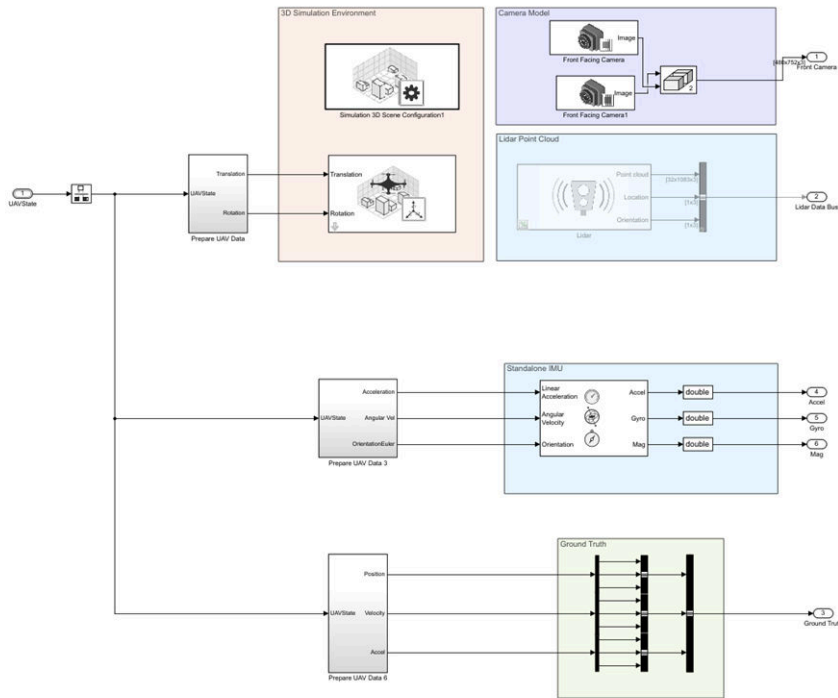

Figure 4. Visual-Inertial Odometry simulation setup using MATLAB 2022 Simulink UAV toolbox

Figure 4. illustrates the GNSS degraded environment simulated to analyse the proposed VIO solution to the reference system. GNSS and LIO components are also implemented in the reference system, but we only focus on analysing the visual component performance with our proposed solution. Based on the simulated correspondences, we firstly validate EKF based fusion algorithm under IMU faults condition [9] with visual odometry. In this case, the error state vector contains IMU error measurements (position error, velocity error, attitude error) and Visual Odometry measurements (position error, orientation error).

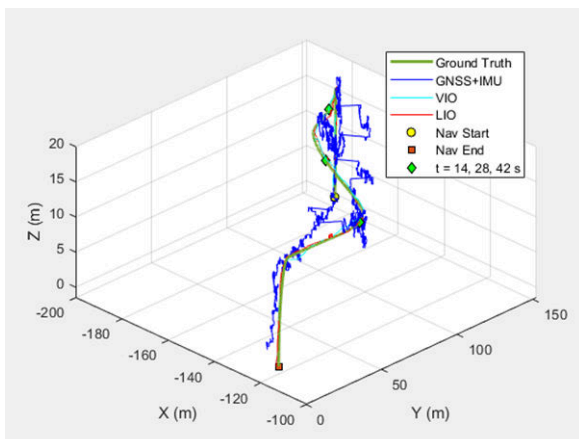

Figure 5. Generated trajectory of Ground truth (green), GNSS (dark-blue), VIO (turquoise-blue), and LIO (red) in the simulated GNSS degraded environment

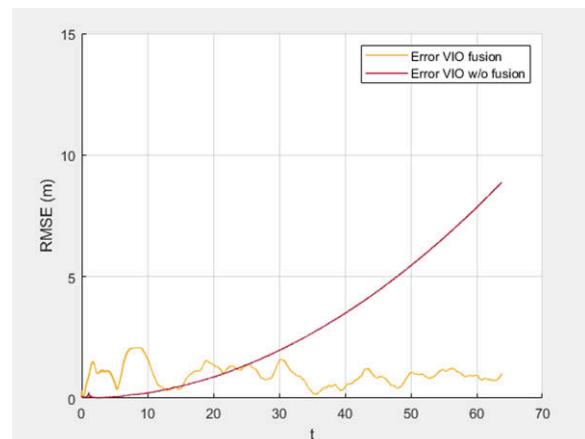

Figure 6. Error comparison between independent filters with and without implementation of the proposed solution



For simulation, we have used MATLAB function ‘insfilterErrorState’ to initialise the drone’s position aligned with IMU parameters for fusion. To compare the efficiency of the EKF model, the filtering result recorded in Figure 6 shows the Visual Odometry positioning error reduction after fusion with IMU.

Table 4 illustrates an RMSE comparison between our proposed system and state-of-art systems. It is noted that the Visual Odometry fault (feature mismatching error) dropped almost 87.21% after fusion with IMU. Here, positioning error in Visual Odometry is higher because we have considered drift conditions in the feature extraction process [8].

*Table 4 Root Mean Square Error comparison for proposed fault-tolerant multi-sensor navigation system*

Positioning	RMSE (m)	Feature Mismatch Error	IMU Faults	Simulation environment
Visual Odometry	4.67	√	-	outdoor
Visual Inertial Odometry	0.5974	√	√	outdoor
VINS-MSCKF [14]	0.56	-	√	indoor
VIO [10]	0.641	-	-	outdoor

The failure of the VO system during feature extraction steps is considered a nominal fault [4], and research has been conducted on mitigating faults such as geometric errors, outlier errors, photometric noise, and 3D feature location errors. A recent study showed that VINS-mono produced significant errors in position estimation under hostile environments due to failure in feature extraction [12]. Another study compared a couple of visual navigation systems, such as VINS-Mono, OKVIS, and VIO, on the dataset EuRoc and their positioning errors are 0.646, 1.147, 0.641[10]. In their paper, they assumed VO with drift-free conditions. In contrast, we calculated the long-range drift of VO [8] while estimating the VIO position, and our proposed system showed high accuracy and robustness in the presence of multiple faults.

## 5. Conclusion

In this paper, we presented the fault-tolerant loosely coupled Visual-Inertial Odometry (VIO) framework, which ensured robust, precise positioning in the presence of multiple faults such as feature mismatching error and IMU random walk noise. The design of VIO only considered errors that occurred from the scenario and propagation model. The proposed system addressed the necessity of failure mode analysis to identify high-risk faults in a system. The experiment was carried out in a MATLAB simulation environment using a synthetic dataset and achieved an 87.21 % increment in position concerning visual odometry. Finally, the solution demonstrates high performance in the considered urban test scenarios and is suitable for an integrated multi-sensor system that operates in GNSS-degraded environments. Future work remains to achieve precise positioning under camera measurement faults with another high-risk visual failure mode, such as feature domain bias simulated in a real-time environment.

## References

- [1] Du, Y., Wang, J., Rizos, C. et al. Vulnerabilities and integrity of precise point positioning for intelligent transport systems: overview and analysis. *Satell Navig* 2, 3 (2021). <https://doi.org/10.1186/s43020-020-00034-8>
- [2] U. I. Bhatti and W. Y. Ochieng, “Failure Modes and Models for Integrated GPS/INS Systems,” *Journal of Navigation*, vol. 60, no. 2, pp. 327–348, 2007.

- [3] Zhu, C., Meurer, M., & Günther, C. (2022) Integrity of visual navigation—Developments, challenges, and prospects. *NAVIGATION*, 69(2). <https://doi.org/10.33012/navi.518>
- [4] Fu, Y., Wang, S., Zhai, Y. et al. Visual odometry errors and fault distinction for integrity monitoring. *AS 3*, 265–274 (2020). <https://doi.org/10.1007/s42401-020-00062-x>
- [5] “Scenario Simulation - MATLAB & Simulink - MathWorks United Kingdom.” [https://uk.mathworks.com/help/uav/scenario-simulation.html?s\\_tid=CRUX\\_lftnav](https://uk.mathworks.com/help/uav/scenario-simulation.html?s_tid=CRUX_lftnav) (accessed Jul. 27, 2022).
- [6] “UAV Package Delivery – MATLAB & Simulink -MathWorks United Kingdom.” <https://uk.mathworks.com/help/uav/ug/uav-package-delivery.html> (accessed Aug. 20, 2022).
- [7] “Stereo Visual SLAM for UAV Navigation in 3D Simulation – MATLAB & Simulink - MathWorks United Kingdom.” <https://uk.mathworks.com/help/uav/ug/stereo-visual-slam-for-uav-navigation-in-3d-simulation.html> (accessed Aug. 20, 2022).
- [8] Jiang, Ruyi & Klette, Reinhard & Wang, Shigang. (2010). Modelling of Unbounded Long-Range Drift in Visual Odometry. 10.1109/PSIVT.2010.27.
- [9] Liu W, Song D, Wang Z, Fang K. Error Overboundings of KF-Based IMU/GNSS Integrated System Against IMU Faults. *Sensors (Basel)*. 2019 Nov 11;19(22):4912. doi: 10.3390/s19224912. Erratum in: *Sensors (Basel)*. 2020 Nov 04;20(21): PMID: 31717949; PMCID: PMC6891410.
- [10] Q. Zeng, C. Gao, Z. Chen, Y. Jin and Y. Kan, "Robust Mono Visual-Inertial Odometry Using Sparse Optical Flow With Edge Detection," in *IEEE Sensors Journal*, vol. 22, no. 6, pp. 5260-5269, 15 March 15, 2022, doi: 10.1109/JSEN.2021.3070603.
- [11] W. Guangyun and Z. Zhiping, "An Improved ORB Feature Extraction and Matching Algorithm," *2021 33rd Chinese Control and Decision Conference (CCDC)*, 2021, pp. 7289-7292, doi: 10.1109/CCDC52312.2021.9602102.
- [12] Yuan C, Lai J, Lyu P, Shi P, Zhao W, Huang K. A Novel Fault-Tolerant Navigation and Positioning Method with Stereo-Camera/Micro Electro Mechanical Systems Inertial Measurement Unit (MEMS-IMU) in Hostile Environment. *Micromachines (Basel)*. 2018 Nov 27;9(12):626. doi: 10.3390/mi9120626. PMID: 30486464; PMCID: PMC6315599.
- [13] Liao, J., Li, X., Wang, X. *et al.* Enhancing navigation performance through visual-inertial odometry in GNSS-degraded environment. *GPS Solut* **25**, 50 (2021). <https://doi.org/10.1007/s10291-020-01056-0>
- [14] Nam DV, Gon-Woo K. Robust Stereo Visual Inertial Navigation System Based on Multi-Stage Outlier Removal in Dynamic Environments. *Sensors (Basel)*. 2020 May 21;20(10):2922. doi: 10.3390/s20102922. PMID: 32455697; PMCID: PMC7288036.
- [15] Zhang C, Liu Y, Wang F, Xia Y, Zhang W. VINS-MKF : A Tightly-Coupled Multi-Keyframe Visual-Inertial Odometry for Accurate and Robust State Estimation. *Sensors (Basel)*. 2018 Nov;18(11) E4036. doi:10.3390/s18114036. PMID: 30463261; PMCID: PMC6263887.
- [16] Zhao, S., Lin, F., Peng, K. *et al.* Vision-aided Estimation of Attitude, Velocity, and Inertial Measurement Bias for UAV Stabilization. *J Intell Robot Syst* **81**, 531–549 (2016). <https://doi.org/10.1007/s10846-015-0206-2>
- [17] H. Jiang, T. Li, D. Song and C. Shi, "An Effective Integrity Monitoring Scheme for GNSS/INS/Vision Integration Based on Error State EKF Model," in *IEEE Sensors Journal*, vol. 22, no. 7, pp. 7063-7073, 1 April 1, 2022, doi: 10.1109/JSEN.2022.3154054.

2022-11-04

# A fault tolerant multi-sensor fusion navigation system for drone in urban environment

Tabassum, Tarafder Elmi

German Institute of Navigation

---

Tabassum TE, Petrunin I, Rana Z. (2022) A fault tolerant multi-sensor fusion navigation system for drone in urban environment. In: POSNAV 2022: Positioning and Navigation for Intelligent Transport Systems, 3-4 November 2022, Berlin, Germany

<https://dspace.lib.cranfield.ac.uk/handle/1826/18740>

*Downloaded from Cranfield Library Services E-Repository*