

Review

Artificial Intelligence and Bio-Inspired Soft Computing-Based Maximum Power Plant Tracking for a Solar Photovoltaic System under Non-Uniform Solar Irradiance Shading Conditions—A Review

Amjad Ali ^{1,*}, Kashif Irshad ¹, Mohammad Farhan Khan ², Md Moinul Hossain ³,
Ibrahim N. A. Al-Duais ⁴ and Muhammad Zeeshan Malik ⁵

- ¹ Interdisciplinary Research Center for Renewable Energy and Power Systems (IRC-REPS), King Fahd University of Petroleum & Minerals, Dhahran 31261, Saudi Arabia; Kashif.irshad@kfupm.edu.sa
² School of Water, Energy and Environment, Cranfield University, Bedford MK43 0AL, UK; farhan7787@gmail.com
³ School of Engineering, University of Kent, Canterbury CT2 7NT, UK; M.Hossain@kent.ac.uk
⁴ Civil & Environmental Engineering Department, King Fahd University of Petroleum & Minerals, Dhahran 31261, Saudi Arabia; g200927910@kfupm.edu.sa
⁵ School of Electronics and Information Engineering, Taizhou University, Taizhou 318000, China; malik4one@yahoo.com
* Correspondence: amjad.ali@kfupm.edu.sa; Tel.: +966-53-108-2131



Citation: Ali, A.; Irshad, K.; Khan, M.F.; Hossain, M.M.; Al-Duais, I.N.A.; Malik, M.Z. Artificial Intelligence and Bio-Inspired Soft Computing-Based Maximum Power Plant Tracking for a Solar Photovoltaic System under Non-Uniform Solar Irradiance Shading Conditions—A Review. *Sustainability* **2021**, *13*, 10575. <https://doi.org/10.3390/su131910575>

Academic Editor: Manosh C. Paul

Received: 30 July 2021

Accepted: 20 September 2021

Published: 23 September 2021

Publisher's Note: MDPI stays neutral with regard to jurisdictional claims in published maps and institutional affiliations.



Copyright: © 2021 by the authors. Licensee MDPI, Basel, Switzerland. This article is an open access article distributed under the terms and conditions of the Creative Commons Attribution (CC BY) license (<https://creativecommons.org/licenses/by/4.0/>).

Abstract: Substantial progress in solar photovoltaic (SPV) dissemination in grid-connected and standalone power generation systems has been witnessed during the last two decades. However, weather intermittency has a non-linear characteristic impact on solar photovoltaic output, which can cause considerable loss in the system's overall output. To overcome these inevitable losses and optimize the SPV output, maximum power point tracking (MPPT) is mounted in the middle of the power electronics converters and SPV to achieve the maximum output with better precision from the SPV system under intermittent weather conditions. As MPPT is considered an essential part of the SPV system, up to now, many researchers have developed numerous MPPT techniques, each with unique features. A Google Scholar survey from 2015–2021 was performed to scrutinize the number of published review papers in this area. An online search established that on different MPPT techniques, overall, 100 review articles were published; out of these 100, seven reviews on conventional MPPT techniques under shading or partial shading and only four under non-uniform solar irradiance are published. Unfortunately, no dedicated review article has explicitly focused on soft computing MPPT (SC-MPPT) techniques. Therefore, a comprehensive review of articles on SC-MPPT techniques is desirable, in which almost all the familiar SC-MPPT techniques have to be summarized in one piece. This review article concentrates explicitly on soft computing-based MPPT techniques under non-uniform irradiance conditions along with their operating principles, block/flow diagram. It will not only be helpful for academics and researchers to provide a future direction in SC-MPPT optimization research, but also help the field engineers to select the appropriate SC-MPPT for SPV according to system design and environmental conditions.

Keywords: maximum power point tracking (MPPT); soft computing; solar photovoltaic (SPV); non-uniform solar irradiance

1. Introduction

Fossil fuel depletion and international market price instability diverted the attention of the world to renewable energy technologies (RETs) to fulfill their electricity demand [1,2]. RETs have abstracted the substantial consideration of power industry to focus on research and development and its maximum exploration to satisfy the increasing energy demand in the world [3–5]. Because of the cumulative dissemination of RETs into the traditional power

system, their status has been changed from secondary to primary energy sources [6,7]. Among all the renewable energy sources, solar photovoltaic is considered one of the most promising and sustainable power generation options because of technological developments and per-watt cost reduction in power generation system [8]. However, because of weather intermittency, fluctuations in the solar photovoltaic output are produced. This happens because of non-uniform solar irradiance, which is not uniform between adjacent locations at a short time scale. This non-uniform solar irradiance is considered one of the overbearing or unsolvable reasons in solar PV power generation system, which leads to overall system losses [9]. To achieve optimized and stable output from the PV system under non-uniform solar irradiance conditions, a device named maximum power point tracking (MPPT) is connected between the PV panels and the power converter, as depicted in Figure 1.

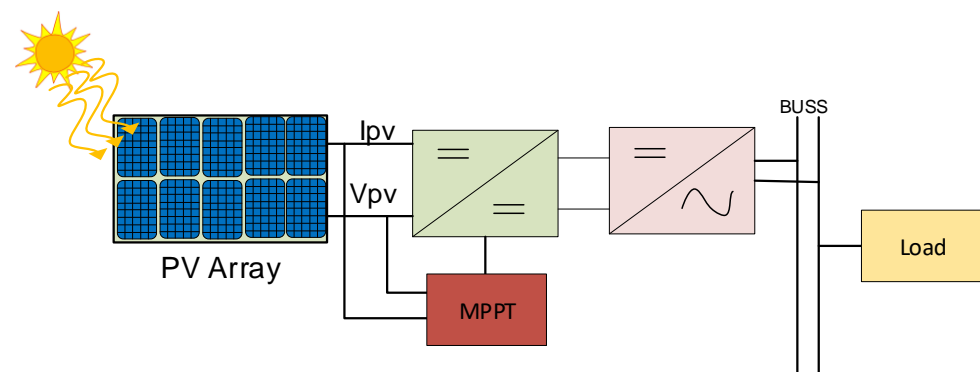

Figure 1. Solar PV system configuration with maximum power point tracking.

Scholars have proposed and practically experimented with different conventional maximum power point techniques to attain the optimized and stable output from the PV system under non-uniform solar irradiation conditions. Unfortunately, solar irradiance's non-linear behavior, temperature deviations and partial shading conditions (PSC) distresses the output characteristics of a PV system. If the whole PV system does not receive uniform solar irradiation, as sketched in Figure 2, this non-linear behavior of solar irradiance directly impacts the power voltage (PV) and current voltage (IV) characteristic curves of the solar PV system. Combining Figure 1 and the non-linear behavior of solar irradiance in Figure 2A,B, IV-PV characteristic curves are sketched in Figure 3: the black line indicates the output of Figure 2A, in which stable 1000 w/m^2 solar irradiance at 25°C is assumed, as per IEC-61215 standard testing conditions. However, the green, red and blue curves concern the array in Figure 2B (A, B and C), where non-uniform solar irradiation conditions are assumed according to the practically installed system, where solar irradiance is not uniform between adjacent locations.

In recent years, different review articles have been published on the maximum power point tracking system under non-uniform solar irradiation conditions. In [4,10–19], conventional MPPT techniques are discussed, and in [16–19], MPPT under partial shading or mismatching solar irradiation conditions are reviewed. Soft computing MPPT techniques are investigated in [20].

A Google Scholar online survey from 2015 to 2021 was conducted to scrutinize how many review papers were published over these years. With the first search query, "Maximum Power Point Tracking Review", 100 articles were found successfully. Subsequently, when the search query was explicitly restricted to "Shading Conditions" and "Non-Uniform Solar Irradiations", only seven on "Shading Conditions" [16,19,21–25] and four review articles on "Non-Uniform Solar Irradiations" [21,26–28] were found, as depicted in Figure 4.

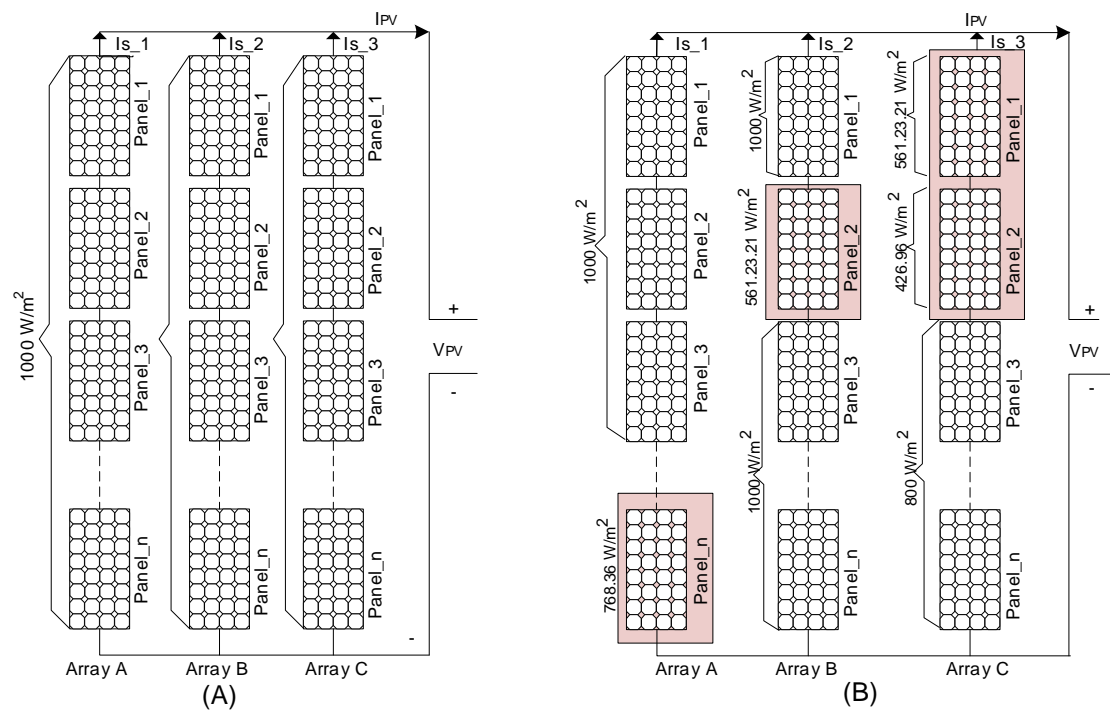

Figure 2. Solar PV Array with (A) uniform and (B) non-uniform solar irradiance [1,2].

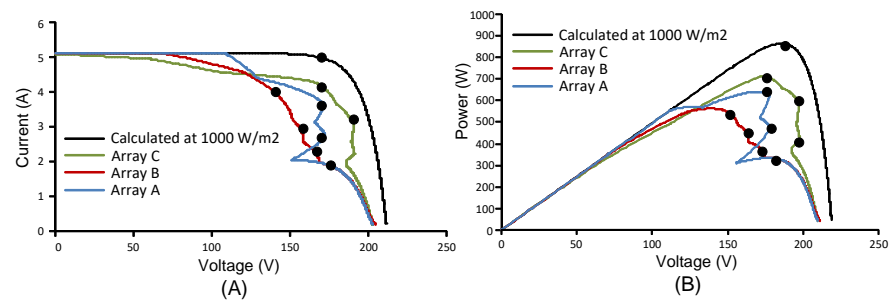

Figure 3. Solar PV IV-PV characteristic curves under stable and variable irradiance: (A) I-V and (B) P-V [1,2].

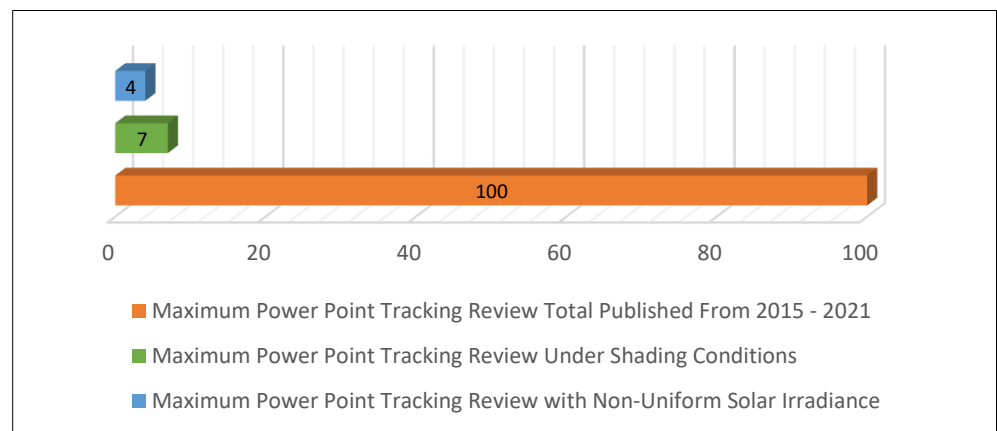

Figure 4. Google Scholar MPPT Search Matrix.

Most of these published review articles discussed a limited number of conventional MPPT techniques under uniform, non-uniform and shading solar irradiance conditions. There is no dedicated review article published so far that considers soft computing MPPT

techniques under non-uniform solar irradiance all in one. Therefore, it is indispensable to publish a comprehensive review article on soft computing-based maximum power point tracking techniques in which almost all the associated research in this area shall be encapsulated in a single source, as depicted in Figure 5. This review paper will lead academics, research scholars and energy engineers to a valued corridor for future research and development in the field of solar power optimization.

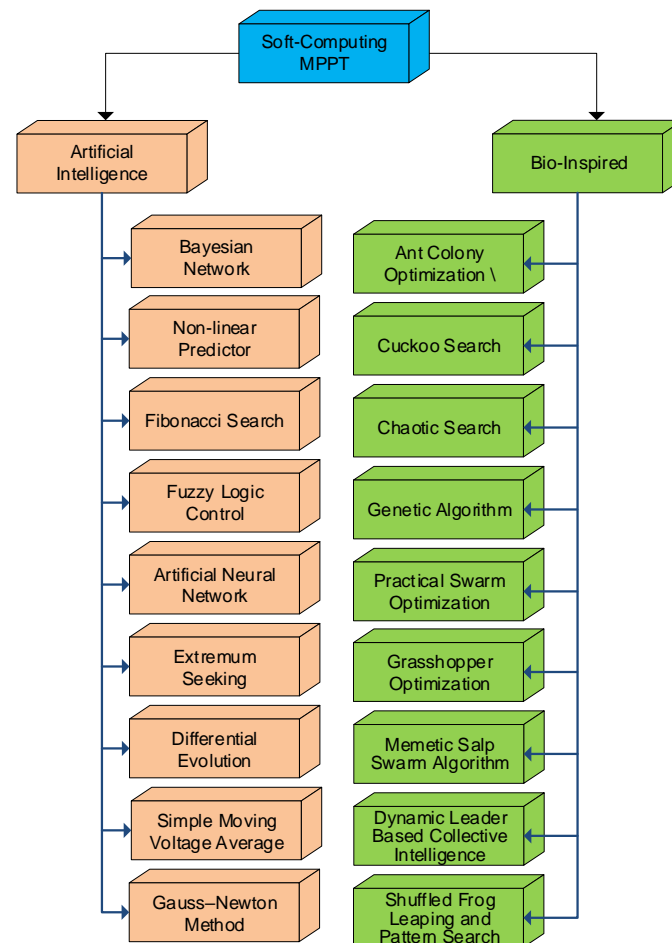

Figure 5. AI- and BI-based soft computing maximum power point tracking techniques.

2. Soft Computing (SC)-Based MPP Tracking

Currently, soft computing-based MPPT techniques have diverted the attention of research to solve the issues of conventional MPPT techniques [1]. The main features of SC-based MPPT algorithms are handling competence to nonlinear behavior of solar PV output and intelligible expertise with a broadened search space.

The working principle of soft computing-based MPPT is to develop a low-cost robust system to achieve tractability for uncertainty, inaccuracy and approximation in a PV system. Furthermore, the greatest vital feature of SC-MPPT is the flexibility in algorithm design, which permits the researcher to develop a robust MPPT scheme as per the system configuration and environment conditions. This is all possible because SC-MPPT are digital. In addition, because of the adaptive nature of algorithms, SC-MPPT is envisioned to be effortlessly adjustable to satisfy the intermittent environmental conditions, such as non-linearity of solar irradiance and partial shading.

2.1. Artificial Intelligence (AI)-Based SC-MPPT Methods

These MPPT methods are suitable to resolve the non-linear behavior of the system's simple mathematical approaches. AI-based SC-MPPT methods eliminate the conven-

tional system's mathematical model repetition to track the GMPP in intermittent conditions; it only require previous data of the system to develop an appropriate design. AI-based SC-MMPT methods provide a flexible, fast and accurate solution for the MPPT problem. FLC and ANNs are the two best examples of AI-based SC-MMPT methods. FLC has received added attraction of the researchers as compare to other AI-based SC-MMPT because it provides higher performance comparing to sophisticate neural or prediction algorithms. ANNs provide a systematic modeling technique, specifically in those multifaceted processes where resolving the process is very difficult by using conventional mathematical methods. Therefore, rapid use of an ANN-based AI SC-MPPT has been observed in MPPT applications.

2.2. Bio-Inspired (BI)-Based SC-MPPT Methods

In the current scenario, BI-based SC-MPPT methods have countersigned the considerable attention of researchers due to their ability to discover near-optimal solutions to complex issues in PV system to track the GMPP. Mostly, BI algorithms have a modest search mechanism with higher optimization effectiveness. Additionally, BI-based SC-MMPTs have no prior knowledge requirement for of the system parameters, which offers substantial benefits with regards to computational effort reduction and a solution for solid multi-variable problems. The most frequently used BI-based SC-MPPT methods are Practical Swarm Optimization (PSO), Genetic Algorithm (GA), Chaotic Search (CS) and Ant Colony Optimization (ACO).

SC-based MPP tracking is an essence and collection of intelligent, flexible and adjustable algorithms that are firmware-base and digital in nature, which are capable of finding the most cost-effective, robust and controllable solutions to solar photovoltaic (PV) optimization problems. These algorithms are made using programming software and computer coding. Due to the flexibility of its algorithms, which is one of the main attributes of SC method, it can be used to develop MPPT schemes that are quite robust. In addition, it is effective in solving optimization problems of solar PVs, which have multiple constraints. The PV characteristics curve presents a time-varying and nonlinear MPP problem due to variations in the condition of the environment—mainly due to temperature and solar irradiance. Some of the SC main parameters taken under consideration throughout the processing and design phases for solving maximum power point tracking problems are described as follows.

2.3. Generalized Processes of SCMPPT

There are four main processes which the soft computing-based MPPT process are categorized into, i.e., the initialization step, the reproduction step, the selection step and the stopping criterion. The population is generated with a number of candidates (n) during the initialization step. During the reproduction step, the second process of SC, the parents chosen from the first step are used to produce descendants based on the SC technique's articulated equation, which is in turn based on the weather conditions and specific PV design problems. The selection step follows, during which a population number (n) is chosen to become the new parents of a new iteration of the initialization and reproduction steps. These three steps are iterated until a criterion, namely the stopping criterion, is reached. When this condition is met, the process is halted and the last generation of descendants is considered to be the solution of the optimization problem. The stopping criterion is chosen based on the desired output of the problem.

2.3.1. Initialization

In SC-MPPT methods, the number of elements (n) refers to the keyword population, in which each element is considered as an impending solution of the problem. Choosing an oversized population results in an unnecessary prolonging of the processing time, while an inadequately smaller size results in a solution of the system that is poor and unreliable.

Thus, striking a balance in sizing the population is crucial in order to reach a reliable solution. A number of population size selection methods are discussed in [20,21].

2.3.2. Reproduction

This is a vital step in the SC-MPPT methods, during which the population chosen in the earlier step, named the parent, is used to produce a subsequent generation, named the descendant, via an algorithm. The algorithm used in this step distinguishes the capability of each SC-MPPT method to produce the next generation. Some algorithms are based on the social behavior insects or animals, such the Ant Colony Optimization (ACO), the Particle Swarm Optimization (PSO) and the Cuckoo Search (CS) methods. On the other hand, other algorithms are based on natural genetic evolution, such as Extremum Seeking (ES), Genetic Algorithm (GA) and Differential Evolution (DE) methods. For example, the production of the population is achieved by applying Lévy flight in the CS method and by utilizing particle velocity in the PSO method, which are precise reproduction operatives, while the latter methods utilize genetic operators for such a recombination, also known as crossover, and mutation to achieve the same task. A randomly chosen individual's value is changed in the mutation operator, while two individuals exchange some parts in the recombination operator.

2.3.3. Selection

This step entails the process of selecting the members of the population that are most fit to produce the subsequent generations based on how they fit the required global solution and whether they help in inducing a speedy convergence to that solution. The process of selection is based on the fitness function and should be carefully chosen. The literature offers proposed selection schemes, which are explained in [26,27].

2.3.4. Stopping Criterion

This is the last phase of SC-MPPT methods, where, as stated previously, the algorithm is halted when one or more predefined termination conditions are met and the members of the last generation are recognized as the optimum solution to the MPPT optimization problem. The following are the most widely used stopping criteria:

- (a) Generation of a predefined number of iterations (n). With this criterion, the algorithm is halted after reaching a certain number of iterations, which is defined at the onset of the SC algorithm.
- (b) Convergence of the population. This particular condition halts the algorithm when the value difference between the maximum and minimum values of the members of the generation is within a certain acceptable value.
- (c) Finest fitness threshold. When the value of (P_{PVBest}), also known as the objective function, becomes lower than the predefined value of ($P_{PVDefined}$), this condition kicks in and stops the algorithm.
- (d) Fitness convergence. When the difference in the objective function (P_{PV}) between the maximum and minimum becomes lower than a predefined recommended tolerance values for all members of the population.

2.4. Bayesian Network Method (BN)

This method, which is also known as the method of the probabilistic neural network, enhances the tracking ability of the SC algorithm to determine the direction of the maximum power point by utilizing a multidimensional MPP tracking algorithm based on a random variables probability combination and by using a combination of algorithms [29,30]. The mechanism of this method is illustrated in Figure 6.

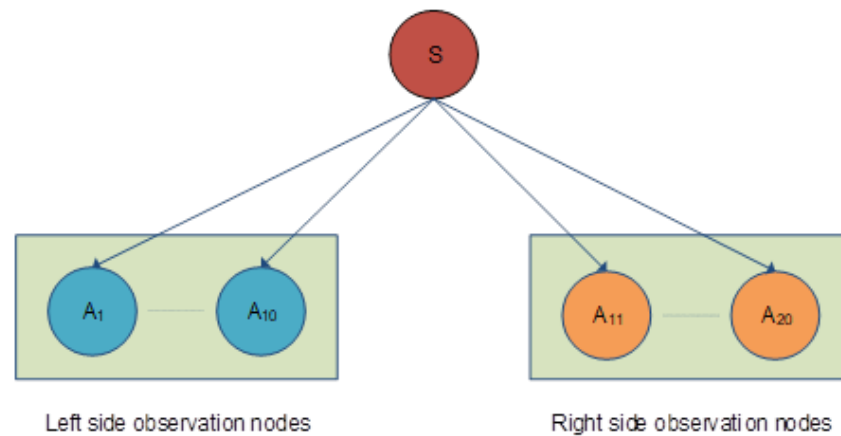

Figure 6. Bayesian network information fusion for MPPT [29].

For example, as illustrated in the aforementioned Figure 6, two MPPT methods, such as incremental conductance and particle swarm optimization, are used to configure a Bayesian Network. This contains twenty nodes $[A_1, A_2, \dots, A_{20}]$, which are then parted into right and left block nodes that contain an equal number of nodes; A_1 to A_{10} for the left station and A_{11} to A_{20} for the right one, with each observation station using a different MPPT tracking method. A projected location after Bayesian fusion is denoted with the character S [31,32]. After that, the observations of both stations are then checked to see whether their entries match with a value of 1 attributed to matching points and 0 to non-matching points. Thus, the best-known nodes are given a probability, which will help in determining the MPP by following the Equation (1) [33]:

$$P(S|A_1, \dots, A_N) = \frac{1}{z} P(S) \prod_{n=1}^N P(A_n|S) \quad (1)$$

where $z = \int_s P(S) \prod_{n=1}^N P(A_n|S) dS$ and the provisional possibilities $P(A_i|S)$ can be appraised for training the samples. These are then saved in a provisional appraised table.

2.5. Non Linear Predictor Method (NLP)

In the NLP method, an algorithm is used to determine the maximum power point via using a predictor function. This function is based on the power-voltage (P–V) and current-voltage (I–V) graphs, with the latter being the more widely used in most cases [34]. The algorithm chooses the maximum power point by using previous duty cycle input and the resultant data for the power points. Shown in Figure 7, points, D_1 , D_2 and D_3 represent the previous data cycles, which resulted in power points P_1 , P_2 and P_3 . The predictor function then uses those data points to generate a new duty cycle with point D_{m1} and its corresponding power point P_{m1} at point A. However, P_{m1} and P_{mpp} do not match on the P–V curve, which leads to the generation of a new duty cycle by the predictor function with power point P_{m2} and D_{m2} . P_{m2} does not match P_{mpp} at B and the predictor function again generates another cycle. This process is repeated until an accurate duty cycle D_{mn} is reached, where its P_{mn} matches P_{mpp} [35,36].

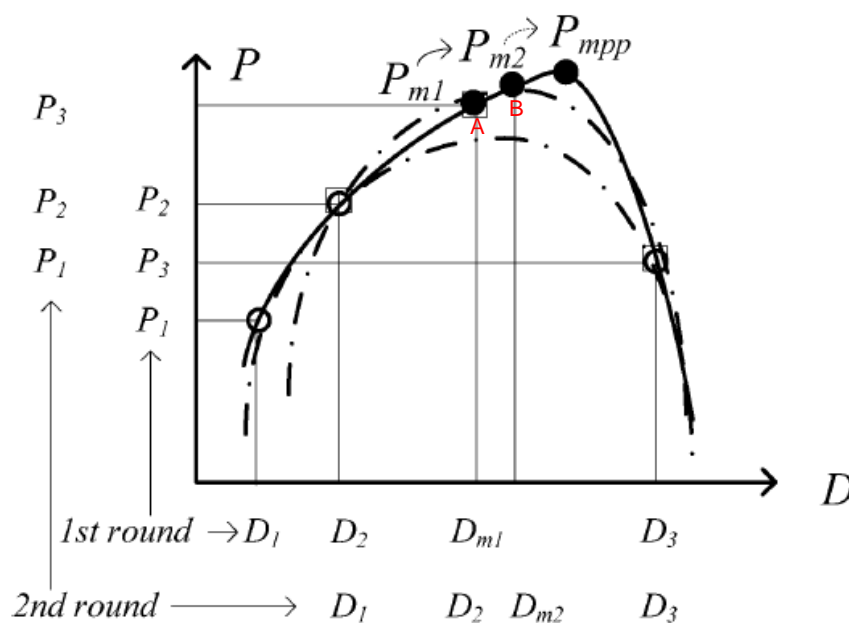

Figure 7. MPP tracking with the non-linear predictor [35].

The main drawback of this method is that it cannot predict multiple power peaks, such as in the case of PV panels in partial shading environments, which limits the method’s overall competency. On the other hand, this method’s main positive attribute is the ease of its implementation and rapid convergence in environments that have quickly varying temperatures and irradiance.

2.6. Ant Colony Optimization Method (ACO)

Multiple studies [37–44] focus on the use of the ACO method in tracking the Global Maximum Power Point, utilizing a variety of MPPT techniques. The Ant Colony Optimization method is based on the phenomenon of ants’ behavior in following the shortest path towards their colony [42]. It is another form of the Swarm Optimization (SO) method and has recently been used simultaneously with other MPP tracking methods in order to find the global MPP in real-time by continuously monitoring the voltage and current in solar PV systems with varying weather. The monitoring is achieved by using only one pair of current and voltage sensor, which is an advantage for this method. Another advantage is its fast convergence in partially shaded and non-uniform conditions, which does not depend of the initial conditions and does not require previous knowledge of the characteristics of the PV array.

ACO methods are calculated based on Equation (2):

$$G_i(x) = \sum_{i=1}^K \omega_i \delta_i^i(x) = \sum_{i=1}^K \omega_i (1/(\sigma_i^i \sqrt{2})) \exp(-\frac{(x - \mu_i^i)^2}{2\sigma_i^{i2}}) \tag{2}$$

where $G_i(x)$ is known as the Gaussian kernel for the i th proportions of the solution and $\delta_i^i(x)$ is the sub i th gaussian function for the i th proportions of the solution

2.7. Cuckoo Search Method (CS)

This method is based on how cuckoo birds lay eggs in nature, with the parasitic brood reproduction approach being its inspiration source. Cuckoo birds do not brood over their eggs but lay them in other birds’ nests, with each laid egg having a probability of failure and success. Failure occurs when the birds discover the egg and either destroy it, push it out of the nest or change the nest totally, while success happens when the egg is not recognized and nurtured until maturation. The probability of discovery is $p_a = \in [0, 1]$ [45,46]. The CS method concept is similar to that of the Perturbed and Observed (P&O) method, which

uses particles. However, the CS method appropriates the step sizes based on the Lévy flight law ($y = l^{-\lambda}$), with y being the flight length, which has an infinite variance since $1 < \lambda < 3$ [47–49]. In this method, two variables are required to be predefined in order to trace the maximum global power point, which are: (a) the sample size step α and (b) the solar PV array voltage for each sample point (V_i with $i = 1, 2 \dots, n$), where n is the number of the points. The MP fitness is dependent on J , which is the fitness curve function that is defined as $J = f(V)$. The new voltage points are created by following a Lévy flight, as shown in Equation (3):

$$V_i^{t+1} = V_i^t + \alpha \oplus \text{levy}(y) \tag{3}$$

As illustrated in Figure 8, the maximum power point tracking is shown in a system that is partially shaded with global and local MPPs. By using the CS method, three samples are chosen, labeled X in green color, Y in red and Z yellow. Y^0 is the closest to the maximum power point and X^0 and Z^0 are forced to move (take flight) towards Y^0 during the first iteration. In the second iteration, Z^2 becomes the closest to the maximum power point and the other samples (Y^2 and X^2) move towards it. This process is repeated until the three samples cover the global maximum power point [50].

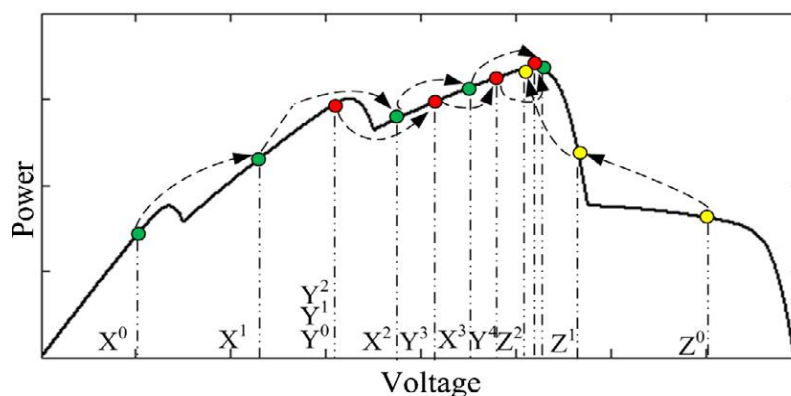

Figure 8. Cuckoo Search under partial shading conditions [45].

2.8. Fibonacci Search Method (FS)

This method is also known as the line search method and is based on the Fibonacci optimization of single variable functions. Furthermore, this method limits the search range and moves it through iterations until an optimum point is reached following a divide and conquer principle [51,52]. The Fibonacci number is generated by Equation (4):

$$C_0 = 0, C_1 = 1, C_n = C_{n-2} + C_{n-1} \tag{4}$$

Thus, the Fibonacci numbers become:

$$C_2 = 1, C_3 = 2, C_4 = 3, C_5 = 5, C_6 = 8, C_7 = 13 \tag{5}$$

The beginning number c_1 and the end number c_N are used to restrict the search line. The direction of the shift for the next iterations is determined by the function’s value at two checkpoints within the range. An example of the method’s functionality is shown in Figure 9, where a_i and b_i are defined as the distance between the break points. The relationships between them is defined in Equation (6):

$$a^i = c_n + 1^{b^i} = c_n \tag{6}$$

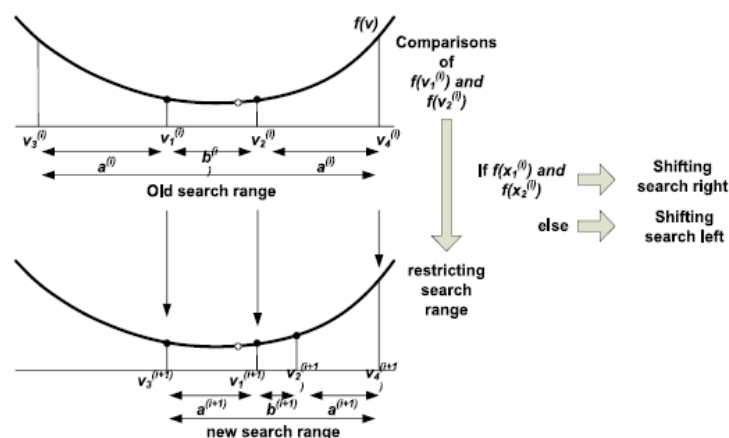

Figure 9. MPP Search with Fibonacci [52].

As illustrated in Figure 9, the Fibonacci Search is terminated when $|b_k - a_k| \leq \delta$ or $|f(b_k) - f(a_k)| \leq \epsilon$ become true, where δ and ϵ are tolerances that are fixed and predetermined. This is done to maintain the search line range and prevent a swing in the wrong direction in the case of any abrupt changes in the solar insolation. The direction is then decided either to the left or the right, depending on the output power in each iteration.

2.9. Particle Swarm Optimization Method (PSO)

This method was developed based on the behavior of fish schools and bird flocks in travel and in the search for food and is considered to be a stochastic algorithm [53]. In this method, multiple particles search for the right patch and cooperatively exchange the information of their search among themselves as they conduct such a search, as shown in Figure 10. The right path is decided either by the optimum solution found by all of the cooperating particles G_{Best} or by the best local solution P_{Best} . The equation governing the best location is shown in Equation (7), which is as follows [54,55]:

$$x_i^{t+1} = x_i^t + v_i^{t+1} \tag{7}$$

where the velocity v_i represents the step size of the MPPT and is calculated based on Equation (8):

$$v_i^{t+1} = \omega v_i^t + c_1 r_1 \cdot (P_{best,i} - x_i^t) + c_2 r_2 \cdot (G_{best} - x_i^t) \tag{8}$$

where c_1 and c_2 are position constants, r_1 and r_2 are random numbers, ω is the learning factor and v_i^{t+1} is the velocity of the i^{th} swarm.

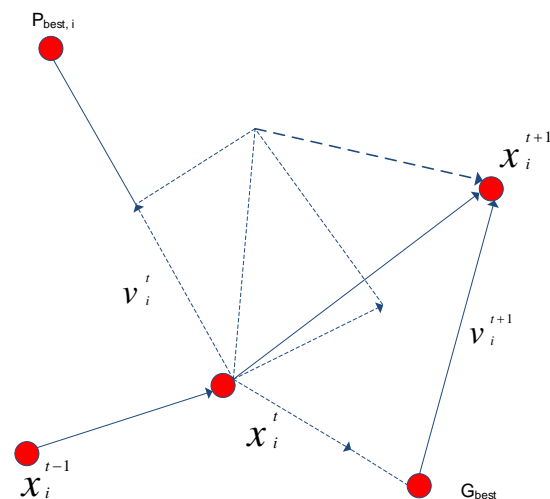

Figure 10. PSO particle movement method [54,55].

There are two directives that each particle follows in this method, which are either to (a) move towards the best position based on the shared information or (b) keep moving towards the local best location based on the previous information gathered, thus leading to each particle reaching or getting as close as possible to the optimum solution [56].

2.10. Fuzzy Logic Control Method (FLC)

In this method, the maximum power point is determined via the use of multiple logics, which attribute a binary value (1 if true and 0 if false) to the elements of the system and use that two-state condition to compare and create the generations [11,57–61]. Due to the fact that the FLC method does not elaborate mathematical equations, it is a suitable option for systems with non-linear control. In addition, the performance of the algorithm is totally dependent on the rules and the parameters of the membership functions set by the developer and, thus, depend on the expertise of the developer to track the maximum power point. The development of the FLC is achieved by Equations (9) and (10), which are as follows:

$$\frac{P_{PV}(k) - P_{PV}(k-1)}{i_{PV}(k) - i_{PV}(k-1)} \quad (9)$$

$$CE(k) = E(k) - E(k-1) \quad (10)$$

As illustrated in Figure 11, there are four principal blocks that the FLC design entails, which are [61]:

- The fuzzification block; this block converts the elements of the system from numerical values to binary values that are either 1 or 0.
- The knowledge base block; the function of this block is to contain the controlling regulations and the data bank of the linguistic explanations set by the developer.
- The inference engine block, which takes the fuzzified values from the fuzzification block and applies the regulations from the knowledge block to make decisions on what elements satisfy the regulations, which are passed to the next block.
- The defuzzification block, which transfers the values that satisfied the inference engine from binary values into a defuzzified control action.

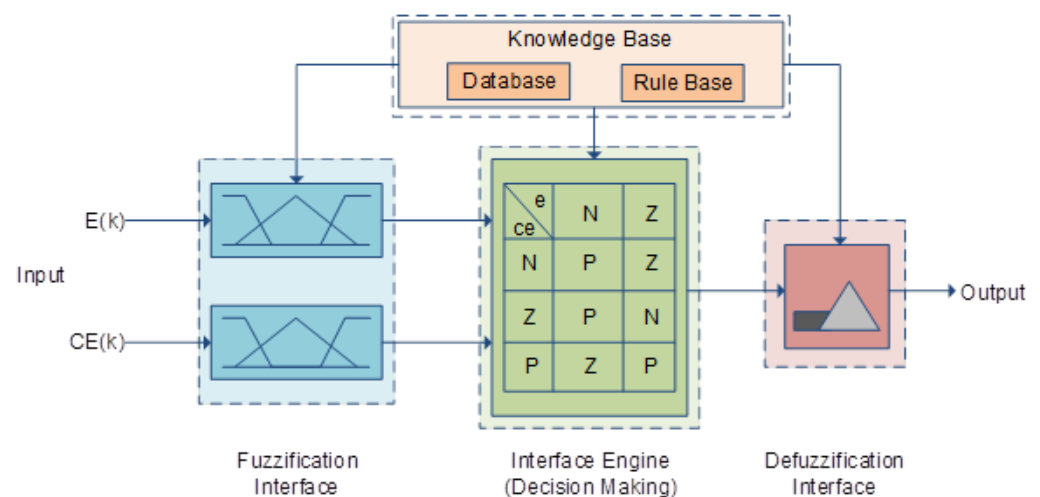

Figure 11. Fuzzy logic control block diagram [57].

2.11. Artificial Neural Network Method (ANN)

The artificial neural network is usually implemented in nonlinear photovoltaic systems in order to approximate the maximum power point where it reports more adequate results in comparison to other more traditional maximum power point tracking methods [59,62–65]. The method is inspired by the biological neural networks (BNN). In the ANN-based MPPT method, a large number of points, also known as nodes or neurons,

are stacked in layers which are interlocked. An example of a feed-forward neural network system configuration is illustrated in Figure 12, where the system consists of an input layer followed by one layer or several layers, which are hidden, and an output layer. All of the nodes in a feed-forward artificial neural network system are linked to each other and organized in contiguous layers that employ synaptic weights, as explained in [66].

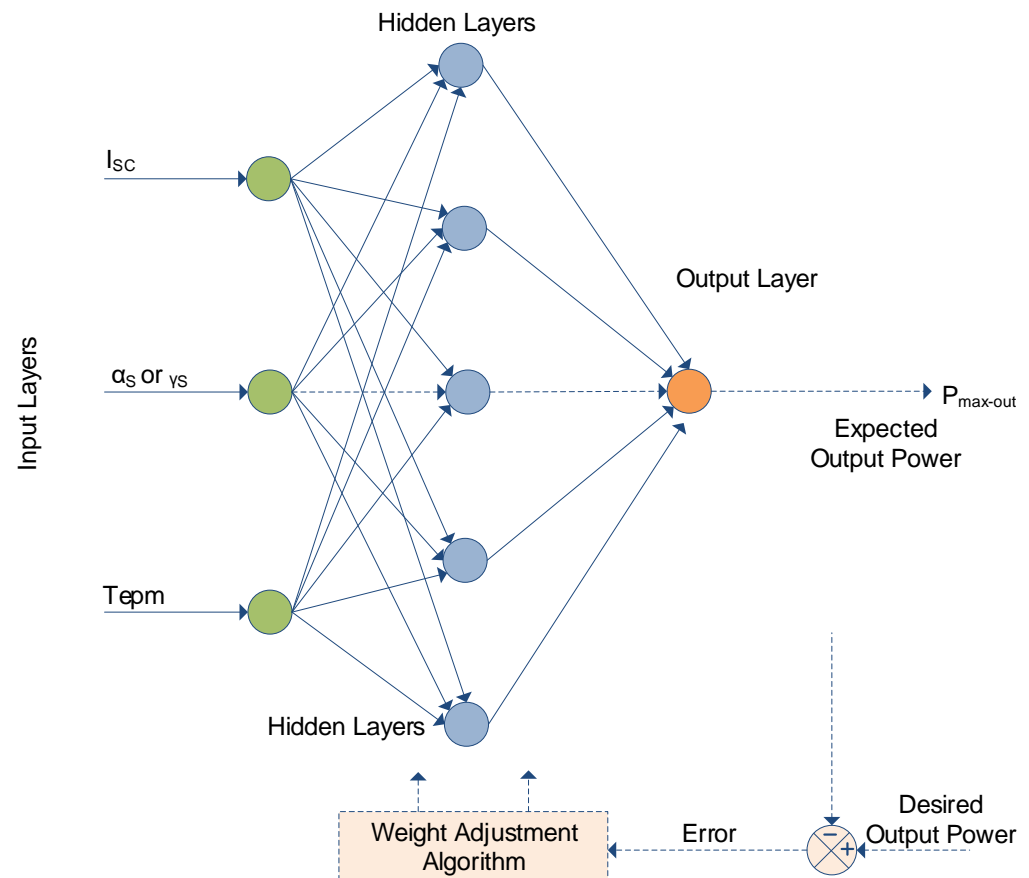

Figure 12. ANN feed-forward approximation function [66].

2.12. Extremum Seeking Method (ES)

As illustrated in Figure 13, this method works by employing the ripples generated by the switching converter to calculate sinusoidal perturbation of the V-P curve as well as its slope. In a system that has a non-linear input, the output y oscillates around the average value when a low-amplitude sinusoidal function is summed with the input signal x . Then, the slope of the function can be used to track the MPP of the photovoltaic system, as sketched in Figure 14 [67,68].

By employing an algorithm by following Equations (11)–(14), which search for the maximum or minimum of a nonlinear graph that is auto-oscillating around its optimum value, the maximum power point of the system can be tracked successfully [69].

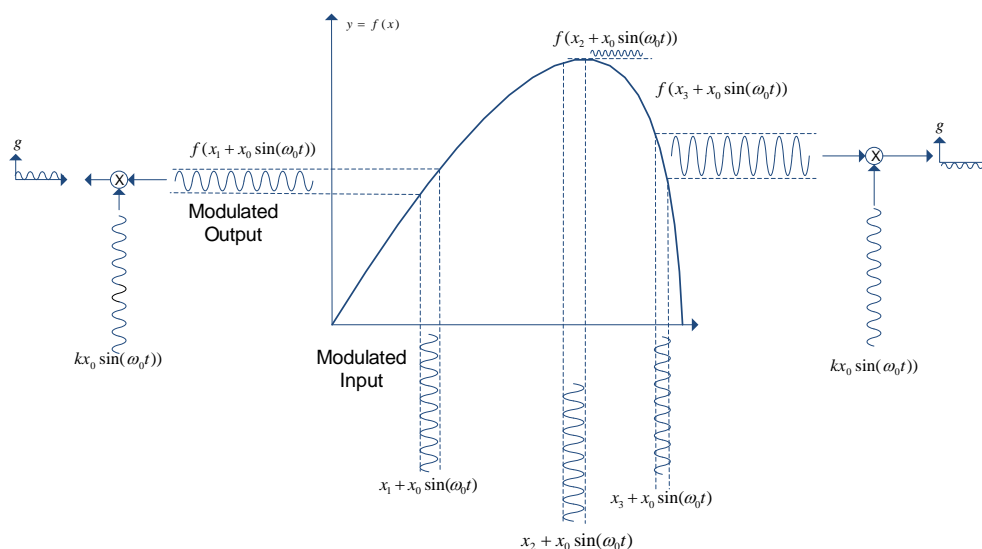

Figure 13. Sinusoidal extremum seeking method [67].

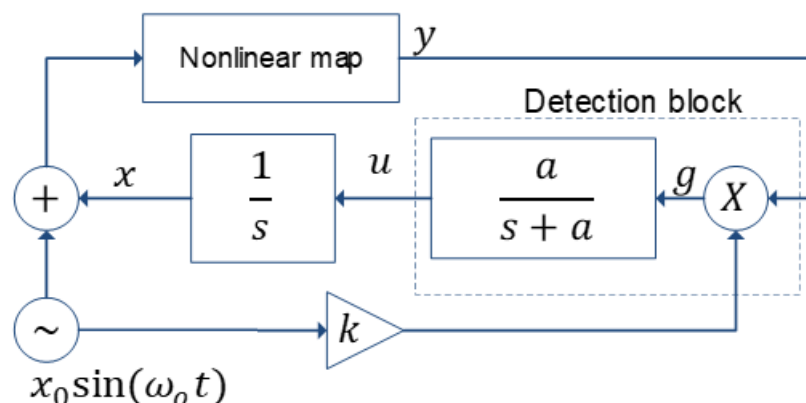

Figure 14. Sinusoidal extremum seeking schema [67].

In detection block u , output is proportionate to the slope of the nonlinear chart, as sketched in Figure 13. x signal is given at the output of the integrator block, and then the output of the nonlinear plotting y will link to:

$$y = f(x + x_0 \sin(\omega_0 t)) \tag{11}$$

Bearing in mind that the sinusoidal perturbation is slight, assuming $x_0 \ll x$, then Equation (11) can be estimated by its development as:

$$y \cong f(x) + \frac{df(x)}{dx} x_0 \sin(\omega_0 t) \tag{12}$$

Therefore, adopting the trigonometric distinctiveness $2 \sin^2(\omega_0 t) = 1 - \cos(2\omega_0 t)$, the output signal at multiplier block g can be estimated by:

$$g \cong f(x) k x_0 \sin(\omega_0 t) + \frac{df(x)}{dx} k x_0^2 \sin^2(\omega_0 t) = \frac{1}{2} \frac{df(x)}{dx} k x_0^2 + f(x) k x_0 \sin(\omega_0 t) - \frac{1}{2} \frac{df(x)}{dx} k x_0^2 \cos(2\omega_0 t) \tag{13}$$

Bearing in mind that the low-pass filter completely mitigates the 1st and 2nd harmonics, the equation of the output filter u can be written as:

$$u = \frac{1}{2} \frac{df(x)}{dx} k x_0^2 * L^{-1} \left\{ \frac{a}{s+a} \right\} \tag{14}$$

where $*$ is the convolution operator, L^{-1} positions for the inverse Laplace transform, and $L^{-1}\{\frac{a}{s+a}\}$ denotes the filter impulse response.

2.13. Chaotic Search Method (CS)

This method randomly optimizes the voltage V_{PV} and the power P_{PV} based on the fitness function [20]. This method performs in a more superior manner compared to the random blindfold search mechanism by using multiple variables or a single one. The core advantages of the chaotic search method in tracking the MPP of PV systems that are non-linear lies in its dynamicity, regularity, randomness and sensitivity [70,71]. In order to improve the efficiency, precision and robustness of the search method, a dual-carrier chaotic search algorithm is used instead of using a single-carrier algorithm. The mapping of the search algorithm follows Equations (15)–(18), which are as follows:

$$x_{n+1} = yx_n(1 - x_n) \tag{15}$$

$$y_{n+1} = \mu \sin(1 - y_n) \tag{16}$$

where $n = 1, 2, \dots, N$, and the two methods of optimization are:

$$x_i^r = a + x_n(b - a) \tag{17}$$

$$y_i^r = a + \frac{1}{4}(y_n + 2)(b - a) \tag{18}$$

where a and b are two predefined variables for preliminary charting and examination to assess the maximum power points, as shown in Figure 15.

As illustrated in Figure 15, the dual chaotic searching area is limited by the lower power points $P(Y_3^0)$ and $P(Y_2^0)$ and upper power point $P(x_2^0)$, with the previous two points being designated as search endpoints. Thus, the search area is reduced in each iteration until the algorithm is halted at a predefined threshold. The main advantage of the chaotic search method compared to other SCMPPT methods is that the search is initiated randomly within the selected region, thus leading to a faster convergence over multiple MPPs due to the search area being quickly narrowed.

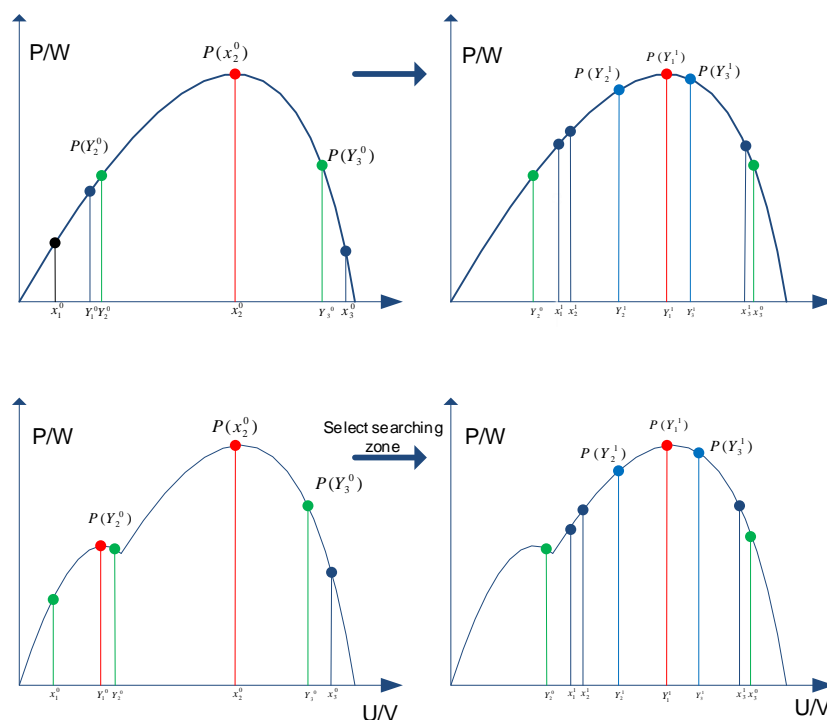

Figure 15. Dual chaotic search method [70,71].

2.14. Differential Evolution Method (DE)

Similar in principle to the Genetic Algorithm method, the differential evolution method is an evolutionary algorithm that is stochastic in nature. The algorithm of this method tracks the maximum power point by maintaining the number of points sampled via the use of its population optimization algorithm [72]. The method uses mutation as the tool for search and selection of the maximum power point by following five steps, which are illustrated in Figure 16 [73].

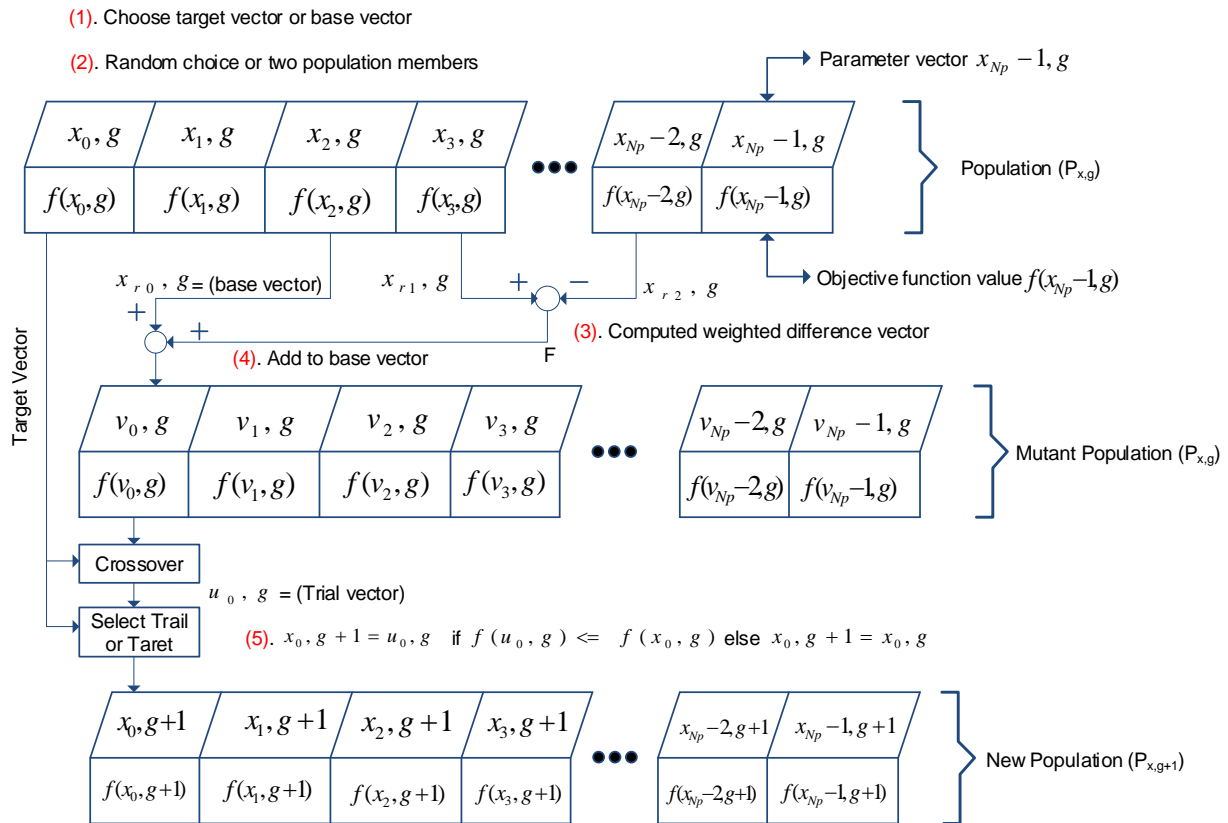

Figure 16. Differential evolution algorithm flow [72,73].

The main characteristic features of this method, which is used for the modeling of photovoltaic arrays as well as for tracking the MPPT, are the fast convergence rate it provides, the ease of its implementation with fewer control parameters, and its capacity in determining the global maximum power point with no regard to the initial PV parameters [72].

DE is easy to develop and implement, as there are only a few parameters involved in the algorithm. In order to generate the final solution in DE, primarily particles of population with a small number of iterations are required and the differences in the particles are used to mutate each other in each iteration. Primarily, DE uses two-dimensional target vectors, where x_i is used as the population for generation each iteration and G , as termed in Equation (19). N_p remains the same as the total number of particles in each iteration:

$$x_{i,G} \quad i = 1, 2, \dots, N_p \tag{19}$$

By following the Equation (19), the first generation of target vectors are appropriately chosen. After that, three target vectors are randomly chosen and factor F is used as given in Equation (20) for mutation and to weight the variance among two of the chosen target vector:

$$v_{i,G} = x_{r1,G} + F * (x_{r2,G} - x_{r3,G}) \tag{20}$$

After three-dimensional target vectors mutation, donor vectors that consist of NP particles are formed. After this step, target vectors and donor vectors are combined or merged through a practice named crossover and formulate the trial vectors, u and i , as given in Equation (21):

$$u_i = \begin{cases} v_i; & \text{if } rand \geq CR \\ x_i; & \text{else.} \end{cases} \quad (21)$$

A selection is decided among the target vectors x and i and trial vectors u and i . Finally, the best chosen as the target vectors in subsequent generation, x_{i+1} , by following Equation (22):

$$x_{i+1} = \begin{cases} u_i; & \text{if } f(u) \geq f(x_i) \\ x_i; & \text{else.} \end{cases} \quad (22)$$

The whole process will repeat as long as the termination condition is met.

2.15. Genetic Algorithm Method (GA)

This method has its roots in the family of evolutionary algorithms, which use techniques related to natural evolution to optimize the problems it is designed for. In this method, which is a multi-objective search optimization method, the inputs are divided into chromosomes or genotypes and then generations are produced by mutation and crossover processes. In the case of photovoltaic MPP tracking, the genotype can be the duty cycle or the voltage (V_{PV}) and can be either defined in terms of their real values or in terms of binary values. Larger initial chromosomes may lead to a substantial increase in the processing time while inducing accurate maximum power point results, and thus, requiring careful consideration of the number of chromosomes to initiate the tracking process. Usually, the GA method is used in conjunction with other MPPT methods to find the maximum power point, such as with ANN [74], FLC [61] and PSO [75], in order to minimize the processing time while maintaining accurate results.

The GA algorithm works by following these three iterative steps:

- (a) Selection, where genotypes are picked from the current population to be passed directly onto the next generation based on their fitness level to the PV equation.
- (b) Crossover, where new genotypes are produced by choosing some characteristics from the first and second generation and combining them.
- (c) Mutation, where new genes are produced to maintain chromosome diversity in produced generations to reach stochastic variability in the gene pool.

2.16. Simple Moving Voltage Average Method (SMVA)

Ali et al. [9,76] proposed a new method for MPP tracking, labeled as the simple moving voltage average method, in which the ripples caused in the photovoltaic output voltage by irregular solar irradiance are recuperated. Illustrated in Figure 17, the PV array configuration proposed by this method is shown, where $Y(n)$ and $X(n)$ are its output and input, respectively. By choosing a number (N) for the moving average buffer, the average output is calculated by holding multiple input signals and averaging them to smoothen the curve, as shown in Figure 18, where the buffer is increased from 10 to 20 points when a noisy signal is recorded. The smoothing is achieved by following Equation (23):

$$\begin{aligned} SMVA_5 &= \frac{M_1 + M_2 + M_3 + M_4 + M_5}{5} \\ SMVA_6 &= \frac{M_2 + M_3 + M_4 + M_5 + M_6}{5} \\ SMVA_7 &= \frac{M_3 + M_4 + M_5 + M_6 + M_7}{5} \\ SMVA_{20} &= \frac{M_{16} + M_{17} + M_{18} + M_{19} + M_{20}}{5} \end{aligned} \quad (23)$$

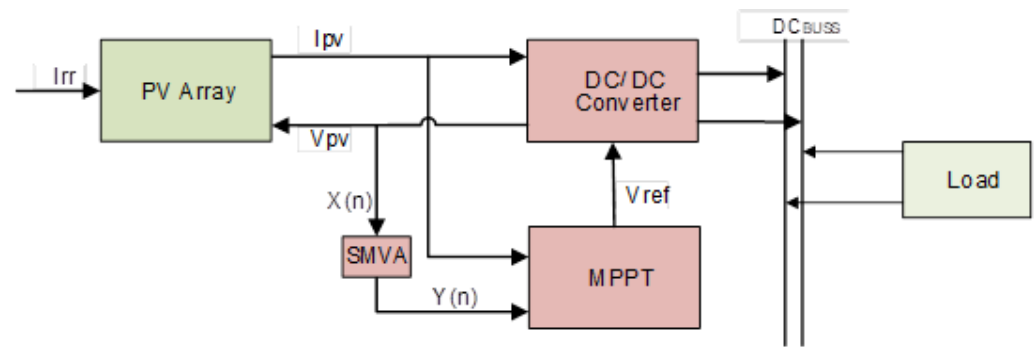

Figure 17. SMVA PV system configuration [2].

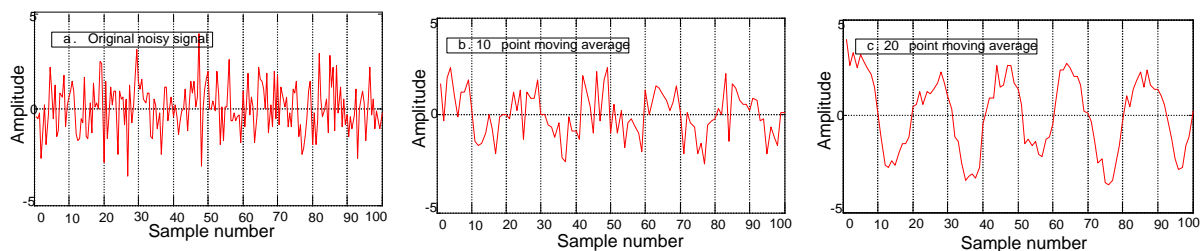

Figure 18. (a) Signal with noise, (b) buffer size with 10 sample points and (c) buffer size with 20 sample points [2].

It is shown that the output signal $Y(n)$ became smoother and more stable as the buffer sample size (N) increased [77].

2.17. Gauss–Newton Method (GN)

This SC-based MPP tracking method, also known as the Newton–Raphson method, is a root finding algorithm [78] and was reported to reach convergence faster than the hill-climbing and steepest descent techniques [79]. This method works by utilizing the slope (first derivative) the slopes rate of change (second derivative) of the photovoltaic power (P_{PV}) to find the number of iterations required to reach convergence as well as the direction of convergence by solving Equation (24), which is as follows:

$$v(k+1) = v(k) \frac{\frac{dp}{dv} \Big|_{v=v(k)}}{\frac{d^2p}{dv^2} \Big|_{v=v(k)}} \quad (24)$$

The main advantage of this method is twofold: firstly that any function can be used as the input and the algorithm will find its roots and secondly that it utilizes an iterative approach that has the capacity to track the MPP in any given photovoltaic system. However, it requires the PV array parameters to be identified or estimated before the process starts, such as R_S and R_P [80,81].

2.18. Grasshopper-Optimized Fuzzy Logic Method (GOFL)

Bukhya and Nandiraju [82] presented a MPPT method based on a novel grasshopper-optimized fuzzy logic. The algorithm tunes the scaling factors of the membership function (MF) to account for uncertainties in the temperature and irradiance of PV systems. An example of the GOFL schematic diagram is shown in Figure 19.

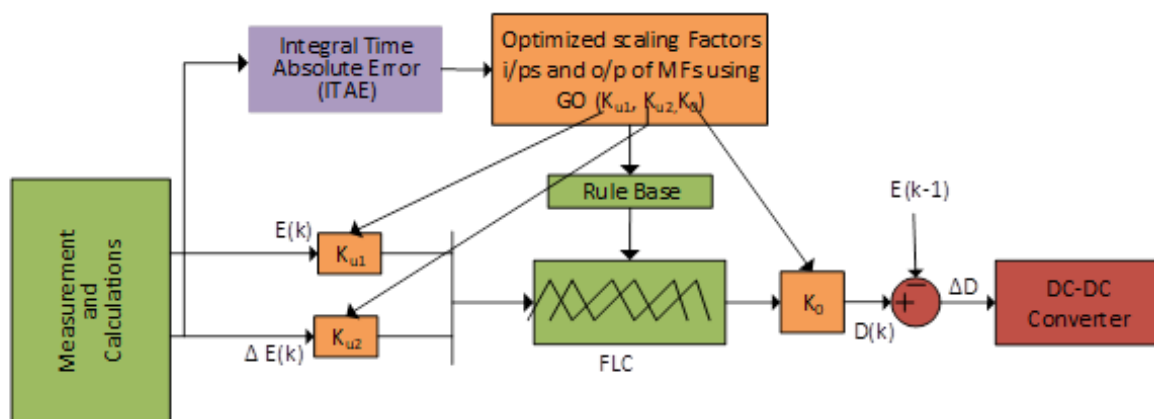

Figure 19. GOFL adaptive fuzzy logic controller [79].

The algorithm starts tracking the GMPP as the duty cycle of the boost converter changes. The current of the photovoltaic array (I_{PV}^k) and voltage (V_{PV}^k) are given to the algorithm as inputs to calculate the power (P_{PV}^k). Since the conditions change after initializing the system, the grasshopper tracks the scaling factors and a new voltage and current are measured and the power is calculated again as (P_{PV}^{k+1}). Based on this new power value, the controller makes the decision to change the duty cycle and the process is repeated until GMPP is reached, as shown the flowchart of Figure 20.

2.19. Memetic Salp Swarm Algorithm (MSSA)

The MSSA method is inspired by the “Salps”, which belong to Salpidae family [83]. Because of Salps’ swarming behavior, they regularly form a swarm named a salp chain in deep oceans, as shown in Figure 21.

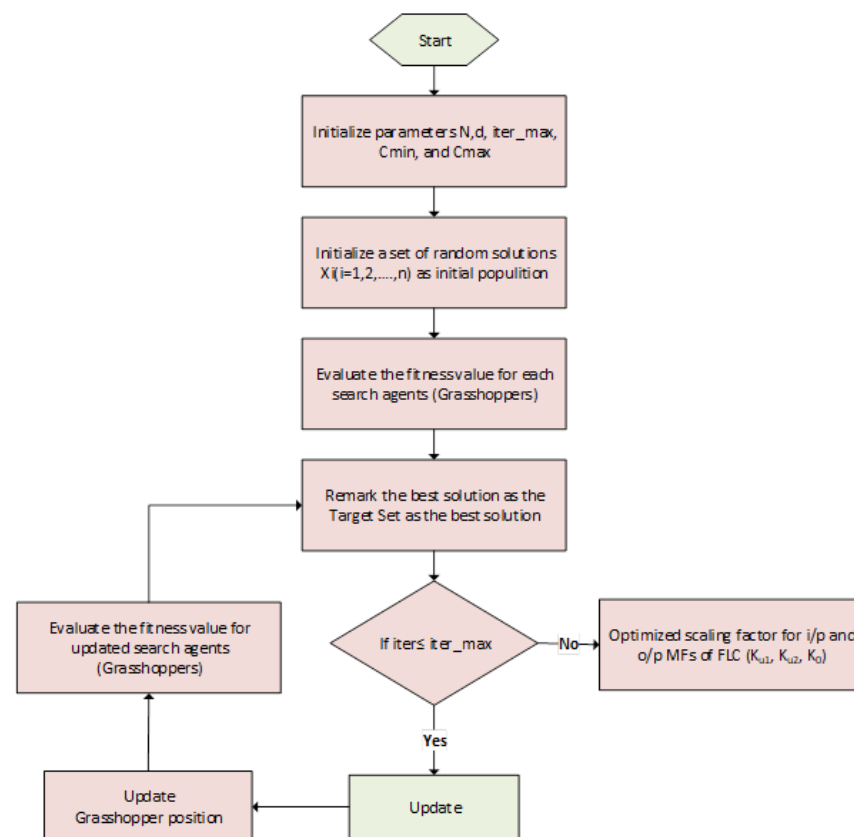

Figure 20. GOFL with the adaptive fuzzy logic control MPP tracking flowchart [79].

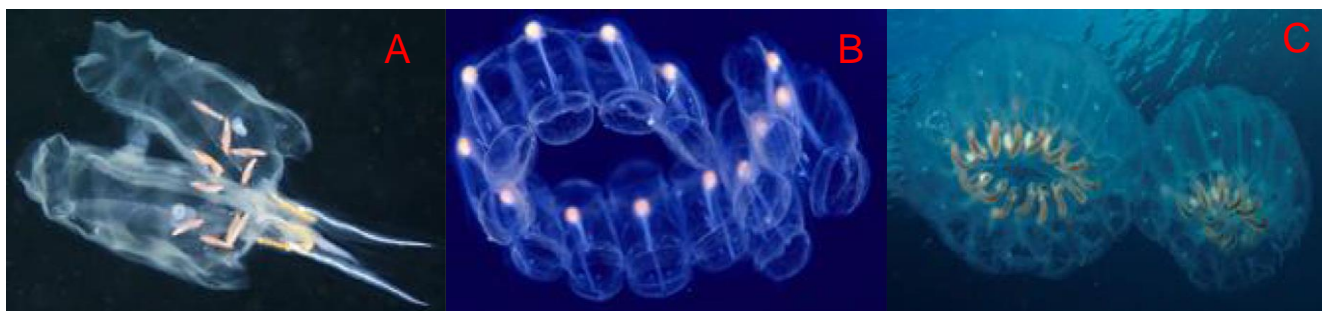

Figure 21. Deep-ocean salp swarm shape and structure. (A) single salp, (B) single salp chain and (C) double salp chains. Adapted with permission from Elsevier (2021) [83].

MSSA is the modified and extended version of the salp swarm algorithm (SSA), with several sovereign salp chains. It also adopted the memetic computing structure to improve the searching capability of SSA grounded on two processes (local and virtual global), as depicted in Figure 22.

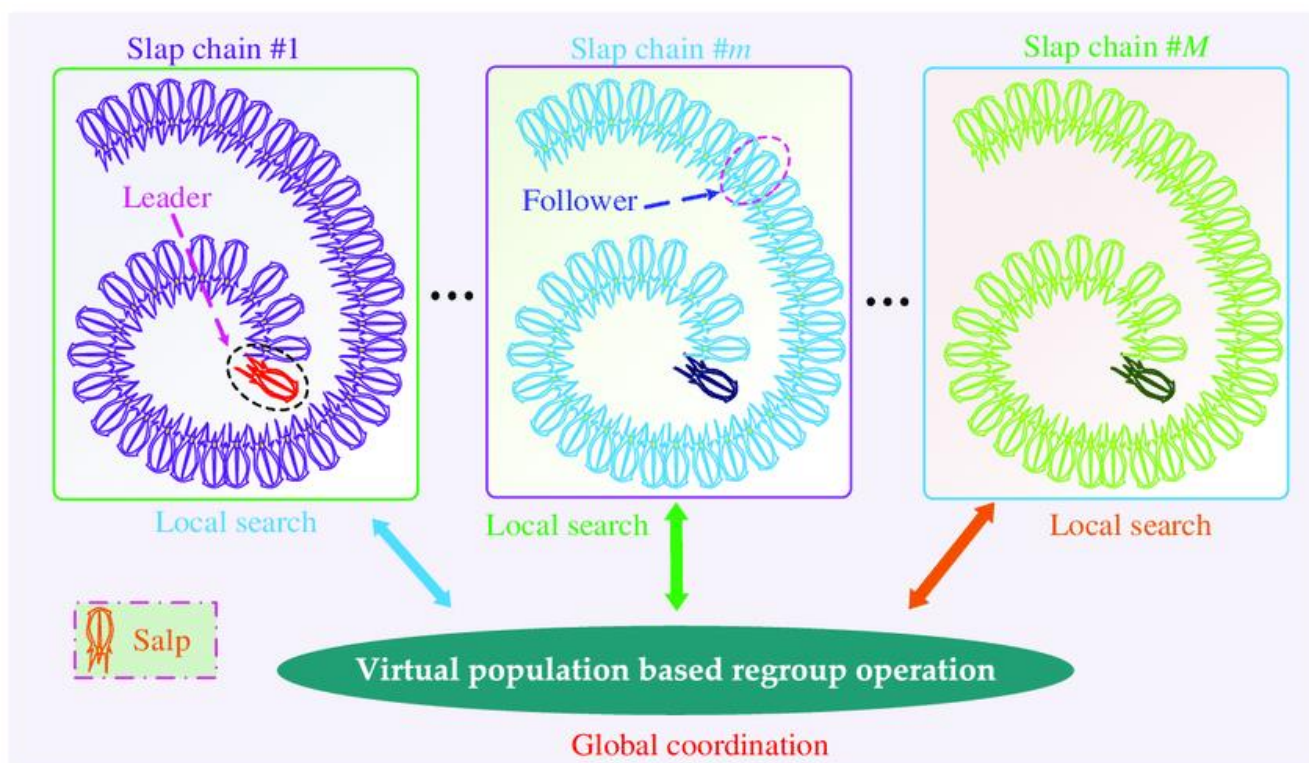

Figure 22. MSSA Optimization framework. Adapted with permission from Elsevier (2021) [83].

Each chain Local search: MSSA contains various similar salp chains. Individually and independently, every salp chain will apply a local search bestowing to the searching in each iteration contrivance. In this procedure, the leader is accountable for controlling the group to look for the food source, whereas the supporters follow each other. For the m^{th} salp chain, the leader position can be updated as in Equation (25):

$$X_{m1}^j \begin{cases} F_m^j + c_1(c_2(ub^j - lb^j) + lb^j), & \text{if } c_3 \geq 0 \\ F_m^j - c_1(c_2(ub^j - lb^j) + lb^j), & \text{if } c_3 < 0 \end{cases} \quad (25)$$

where the superscript j denotes the j^{th} measurement of the searching space. Furthermore, X_{m1}^j is the first salp leader position in the m^{th} salp chain; F_m^j determines the position of the

food sources during the searching process; c_1 , c_2 and c_3 are random numbers, with the existing finest result attained by the m^{th} salp chain; and ub^j and lb^j are the upper and lower bounds of the j^{th} dimension.

Global virtual population coordination: MSSA inhabitants can only be considered as hosts of memes, where a meme is a part of cultural growth. Principally, a meme is selected for enlarged contagiousness among the hosts. Furthermore, the physical features of each distinct will not be altered throughout the global coordination.

In order to advance the convergence immovability, the simulated population will be recuperated into diverse salp chains corresponding to all the salps' qualification values. Henceforward, the recuperate process can be attained corresponding to the descendant order of the suitability value for a supreme optimization, as demonstrated in Figure 23.

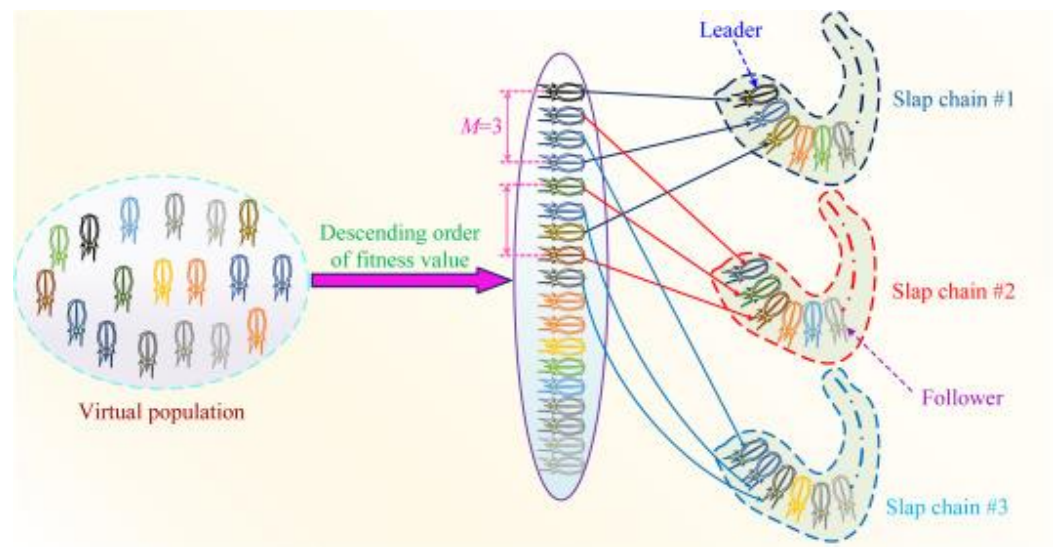

Figure 23. Global coordination of virtual population for regroup operation. Adapted with permission from Elsevier (2021) [83].

The best resolution will be allocated to salp chain #1, the second finest resolution will be allocated to salp chain #2 and so on. Therefore, the rationalized group of the m^{th} salp chain can be termed as in Equation (26):

$$Y^m = \{(x_{mi}, f_{mi}) | x_{mi} = X(m + M(i - 1), :), f_{mi} \quad (26)$$

2.20. Dynamic Leader-Based Collective Intelligence (DLCI)

In [84], a bio-inspired soft computing-based MPPT by the use of dynamic leader-based collective intelligence (DLCI) partial shading conditions is discussed. DLCI comprises manifold sub-optimizers, which are able to attain a considerable broader investigation by effusively cooperating with different searching mechanisms instead of a solo searching mechanism. In order to attain a profound utilization, the sub-optimizer with the recent best solution is picked as the vibrant leader for an effective searching supervision to other sub-optimizers, as depicted in Figure 24.

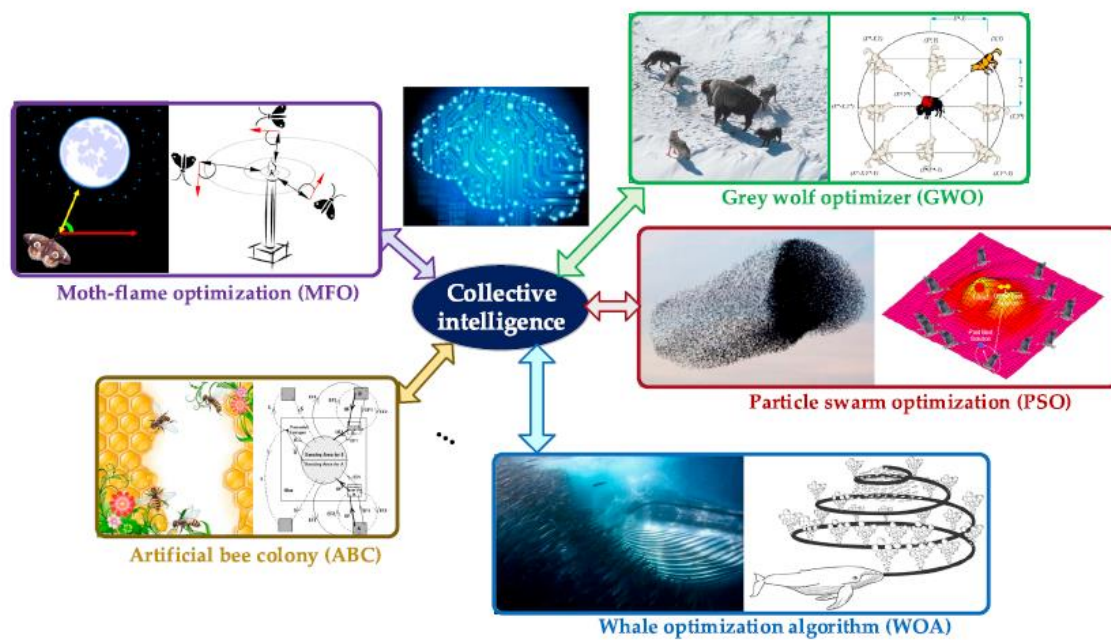

Figure 24. DLCI optimization framework. Adapted with permission from Elsevier (2021) [84].

2.21. Shuffled Frog Leaping and Pattern Search (HSFL-PS)

The Shuffled Frog Leaping Algorithm (SFLA) is inspired by the community behavior of frogs and is one of the magnificent innovations in bio-inspired soft computing optimization algorithms [85]. In [86], to optimize the ANN-based MPPT efficiency, a hybrid shuffled frog leaping and pattern search (HSFL-PS) algorithm is presented. In HSFL-PS, the conventional P&O MPPT is used for MPP tracking, and afterward, ANN is adopted for precise tracking method after training the neuron weights, as shown in Figure 25.

Comparative Analysis

In the literature, numerous soft computing-based MPPT techniques can be found. In this paper, we investigated and discussed the frequently used and practically available range of AI and BI SC-MPPT techniques, which aim to optimize the PV system output under non-uniform solar irradiance or partial shading conditions. In Table 1, all the discussed techniques are surmised based on their speed, accuracy, efficiency, number of sensors and application elements.

Table 1. AI- and BI-based Soft Computing MPPT technique comparisons.

MPPT Technique	Dependency on PV Array	AI- and BI-Based Soft Computing Methods						Circuitry Type		Application	
		Sensor Type			MPP Tracking Speed	MPP Tracking Accuracy	Efficiency	D	A	Grid Connected	Stand Alone
		T	I	V							
AI-Based SC-MPPT Techniques											
Bayesian Network	×	×	✓	✓	M	Me	H	✓	✓	✓	✓
Nonlinear Predictor	×	×	✓	✓	F	H	H	✓	✓	✓	✓
Fibonacci Search	×	×	✓	✓	F	M	M	✓	×	×	✓
Fuzzy Logic Control	✓	×	✓	✓	F	M	H	✓	×	×	✓
Artificial Neural Network	✓	✓	✓	✓	F	M	H	✓	×	×	✓
Extremum Seeking	×	×	✓		F	M	M	✓	×	×	✓
Differential Evolution	×	×	✓	✓	F	M	H	✓	×	×	✓

Table 1. Cont.

AI- and BI-Based Soft Computing Methods											
Simple Moving Voltage Average	✓	×	✓	F	H	H	✓	✓	×	✓	
Gauss–Newton	×	×	✓	✓	F	H	H	✓	×	×	✓
BI-Based SC-MPPT Techniques											
Ant Colony Optimization	✓	✓	✓	✓	F	M	H	✓	×	×	✓
Cuckoo Search	×	×	✓		VF	H	H	✓	×	×	✓
Chaotic Search	×	×	✓	✓	F	M	M	✓	×	×	✓
Genetic Algorithm	×	×	✓	✓	F	M	H	✓	×	×	✓
Practical Swarm Optimization	×	×	✓	✓	F	M	H	✓	×	×	✓
Grasshopper	×	×	✓	✓	F	H	H	✓	×	×	✓
Memetic Salp Swarm Algorithm	×	×	✓	✓	VF	H	H	✓	×	×	✓
Dynamic Leader-based Collective Intelligence	×	×	✓	✓	VF	H	H	✓	×	×	✓
Shuffled Frog Leaping and Pattern Search	×	×	✓	✓	VF	H	H	✓	×	×	✓

T = Temperature, I = Current, V = Voltage, D = Digital, A = Analog, VF = Very Fast, F = Fast, H = High, M = Medium, L = Low.

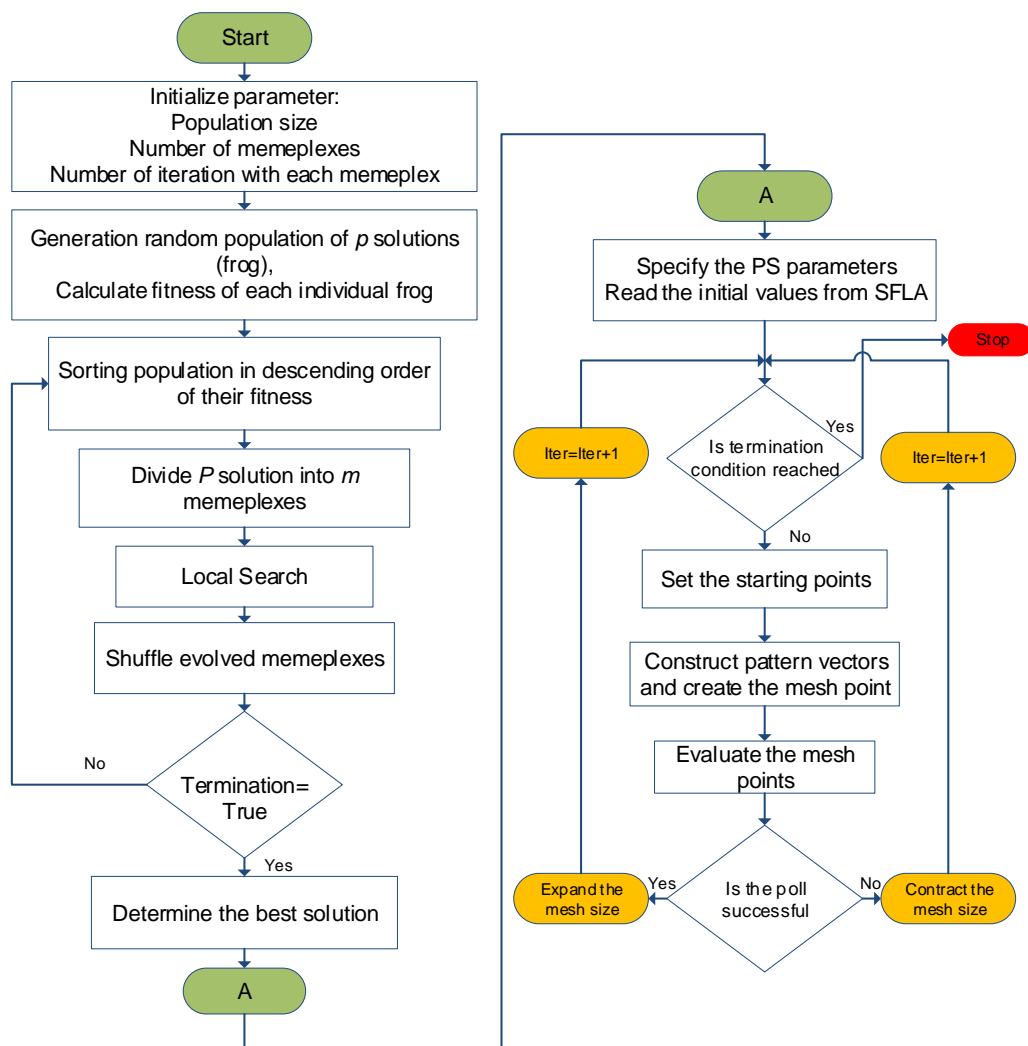

Figure 25. SFL–PS flowchart. Adapted with permission from Elsevier (2021) [86].

3. Conclusions

Among the other sources of renewable energies, solar photovoltaic is considered the most promising source of energy because of the abundant availability of sunlight. However, it has some curbs, such as lower conversion efficiency and weather dependency and intermittency. Therefore, to fetch the maximum power from the solar photovoltaic (SPV) system under variable solar irradiance or shading conditions, the maximum power point tracking technique is installed as an interface in between the power converter and the SPV system. It has always been challenging to pick the correct maximum power point tracking technique for the specific SPV system configurations and weather conditions to attain the maximum output from the SPV system. In this review article, we have investigated and discussed the AI and BI soft computing-based MPPT techniques under non-uniform irradiance and shading conditions techniques presented in the literature. After the assessments of soft computing-based MPPT techniques, the results, based on their application, complexity, sensors and convergence speed, are summarized in Table 1.

After a literature review and a study of the AI and BI soft computing-based MPPT methods, it can be presumed that compared to conventional MPPT techniques, both the AI and BI SC-MPPT are precise and fast in global maximum power point (GMPP) tracking under non-uniform irradiance and partial shading conditions. However, they are difficult to implement because of complex algorithms using embedded technologies.

Author Contributions: Writing-Original Draft Preparation, A.A., I.N.A.A.-D.; Formal Review, K.I. and A.A.; Writing-Review & Editing, A.A. and M.Z.M.; Funding Acquisition, M.M.H. and M.F.K. All authors have read and agreed to the published version of the manuscript.

Funding: This research was funded by Interdisciplinary Research Center for Renewable Energy and Power Systems (IRC-REPS), King Fahd University of Petroleum and Minerals Dhahran (31261), Saudi Arabia, under project number INRE2105.

Data Availability Statement: The data presented in this study are available on request from the corresponding author.

Conflicts of Interest: The authors declare no conflict of interest.

References

1. Ali, A.; Almutairi, K.; Padmanaban, S.; Tirth, V.; Algarni, S.; Irshad, K.; Islam, S.; Zahir, H.; Shafiullah; Malik, M.Z. Investigation of MPPT Techniques Under Uniform and Non-Uniform Solar Irradiation Condition—A Retrospection. *IEEE Access* **2020**, *8*, 127368–127392. [[CrossRef](#)]
2. Ali, A.; Almutairi, K.; Malik, M.Z.; Irshad, K.; Tirth, V.; Algarni, S.; Zahir, H.; Islam, S.; Shafiullah; Shukla, N.K. Review of Online and Soft Computing Maximum Power Point Tracking Techniques under Non-Uniform Solar Irradiation Conditions. *Energies* **2020**, *13*, 3256. [[CrossRef](#)]
3. Marañón-Ledesma, H.; Tomsgard, A. Analyzing Demand Response in a Dynamic Capacity Expansion Model for the European Power Market. *Energies* **2019**, *12*, 2976. [[CrossRef](#)]
4. Verma, D.; Nema, S.; Shandilya, A.; Dash, S.K. Maximum power point tracking (MPPT) techniques: Recapitulation in solar photovoltaic systems. *Renew. Sustain. Energy Rev.* **2016**, *54*, 1018–1034. [[CrossRef](#)]
5. Tantiwechwuttikul, R.; Yarime, M.; Ito, K. Solar Photovoltaic Market Adoption: Dilemma of Technological Exploitation vs Technological Exploration. In *BT-Technologies and Eco-Innovation Towards Sustainability II: Eco Design Assessment and Management*; Hu, A.H., Matsumoto, M., Kuo, C.T., Smith, S., Eds.; Springer: Singapore, 2019; pp. 215–227.
6. Ustun, T.S.; Ozansoy, C.; Zayegh, A. Recent developments in microgrids and example cases around the world—A review. *Renew. Sustain. Energy Rev.* **2011**, *15*, 4030–4041. [[CrossRef](#)]
7. Romankiewicz, J.; Marnay, C.; Zhou, N.; Qu, M. Lessons from international experience for China's microgrid demonstration program. *Energy Policy* **2014**, *67*, 198–208. [[CrossRef](#)]
8. Bódis, K.; Kougiyas, I.; Taylor, N.; Jäger-Waldau, A. Solar Photovoltaic Electricity Generation: A Lifeline for the European Coal Regions in Transition. *Sustainability* **2019**, *11*, 3703. [[CrossRef](#)]
9. Amjad, A.; Wuhua, L.; Xiangning, H. Simple Moving Voltage Average Incremental Conductance MPPT Technique with Direct Control Method under Nonuniform Solar Irradiance Conditions. *Int. J. Photoenergy* **2015**, *2015*, 479178. [[CrossRef](#)]
10. Hossain, M.Z.; Rahim, N.A.; Selvaraj, J.A. Recent progress and development on power DC-DC converter topology, control, design and applications: A review. *Renew. Sustain. Energy Rev.* **2018**, *81*, 205–230. [[CrossRef](#)]

11. Reisi, A.R.; Moradi, M.H.; Jamasb, S. Classification and comparison of maximum power point tracking techniques for photovoltaic system: A review. *Renew. Sustain. Energy Rev.* **2013**, *19*, 433–443. [[CrossRef](#)]
12. Subudhi, B.; Pradhan, R. A Comparative Study on Maximum Power Point Tracking Techniques for Photovoltaic Power Systems. *IEEE Trans. Sustain. Energy* **2012**, *4*, 89–98. [[CrossRef](#)]
13. Andrian, V.; Chang, C.P.; Lian, L.K. A Review and New Problems Discovery of Four Simple Decentralized Maximum Power Point Tracking Algorithms—Perturb and Observe, Incremental Conductance, Golden Section Search, and Newton’s Quadratic Interpolation. *Energies* **2018**, *11*, 2966. [[CrossRef](#)]
14. Koutroulis, F.B.E. Overview of Maximum Power Point Tracking Techniques for Photovoltaic Energy Production Systems. *Electr. Power Components Syst.* **2015**, *43*, 1329–1351. [[CrossRef](#)]
15. Ahmad, R.; Murtaza, A.F.; Sher, H. Power tracking techniques for efficient operation of photovoltaic array in solar applications—A review. *Renew. Sustain. Energy Rev.* **2018**, *101*, 82–102. [[CrossRef](#)]
16. Belhachat, F.; Larbes, C. Comprehensive review on global maximum power point tracking techniques for PV systems subjected to partial shading conditions. *Sol. Energy* **2019**, *183*, 476–500. [[CrossRef](#)]
17. Ishaque, K.; Salam, Z. A review of maximum power point tracking techniques of PV system for uniform insolation and partial shading condition. *Renew. Sustain. Energy Rev.* **2013**, *19*, 475–488. [[CrossRef](#)]
18. Bastidas-Rodriguez, J.D.; Franco, E.; Petrone, G.; Ramos-Paja, C.A.; Spagnuolo, G. Maximum power point tracking architectures for photovoltaic systems in mismatching conditions: A review. *IET Power Electron.* **2014**, *7*, 1396–1413. [[CrossRef](#)]
19. Liu, Y.-H.; Chen, J.-H.; Huang, J.-W. A review of maximum power point tracking techniques for use in partially shaded conditions. *Renew. Sustain. Energy Rev.* **2015**, *41*, 436–453. [[CrossRef](#)]
20. Salam, Z.; Ahmed, J.; Merugu, B.S. The application of soft computing methods for MPPT of PV system: A technological and status review. *Appl. Energy* **2013**, *107*, 135–148. [[CrossRef](#)]
21. Liu, L.; Meng, X.; Liu, C. A review of maximum power point tracking methods of PV power system at uniform and partial shading. *Renew. Sustain. Energy Rev.* **2016**, *53*, 1500–1507. [[CrossRef](#)]
22. Ramli, M.A.; Twaha, S.; Ishaque, K.; Al-Turki, Y.A. A review on maximum power point tracking for photovoltaic systems with and without shading conditions. *Renew. Sustain. Energy Rev.* **2017**, *67*, 144–159. [[CrossRef](#)]
23. Li, G.; Jin, Y.; Akram, M.W.; Chen, X.; Ji, J. Application of bio-inspired algorithms in maximum power point tracking for PV systems under partial shading conditions—A review. *Renew. Sustain. Energy Rev.* **2018**, *81*, 840–873. [[CrossRef](#)]
24. Jiang, L.L.; Srivatsan, R.; Maskell, D.L. Computational intelligence techniques for maximum power point tracking in PV systems: A review. *Renew. Sustain. Energy Rev.* **2018**, *85*, 14–45. [[CrossRef](#)]
25. Hussan, R.; Sarwar, A. Maximum Power Point Tracking Techniques under Partial Shading Condition—A Review. In Proceedings of the 2018 2nd IEE International Conference on Power Electronics, Intelligent Control and Energy Systems (ICPEICES), Delhi, India, 22–24 October 2018; pp. 293–298. [[CrossRef](#)]
26. Dash, S.K.; Nema, S.; Nema, R.K.; Verma, D. A comprehensive assessment of maximum power point tracking techniques under uniform and non-uniform irradiance and its impact on photovoltaic systems: A review. *J. Renew. Sustain. Energy* **2015**, *7*, 063113. [[CrossRef](#)]
27. Kumar, B.; Jha, S.K.; Kumar, T. Review of maximum power point tracking techniques for photovoltaic arrays working under uniform/non-uniform insolation level. *Int. J. Renew. Energy Technol.* **2018**, *9*, 439–452. [[CrossRef](#)]
28. Syafaruddin, S. Review of Maximum Power Point Tracking Control of Photovoltaic Systems in Case of Uniform & Non-uniform Irradiance Conditions. In Proceedings of the Proceeding International Conference on Science and Engineering, Yogyakarta, Indonesia, 12 September 2017; Volume 1, p. xv. [[CrossRef](#)]
29. Keyrouz, F.; Hamad, M.; Georges, S. Bayesian fusion for maximum power output in hybrid wind-solar systems. In Proceedings of the 2012 3rd IEEE International Symposium on Power Electronics for Distributed Generation Systems (PEDG), Aalborg, Denmark, 25–28 June 2012; pp. 393–397.
30. Priyanka, G.; Dash, S.K. A Detailed Review on Intelligent Maximum Power Point Tracking Algorithms. In Proceedings of the 2020 2nd International Conference on Innovative Mechanisms for Industry Applications (ICIMIA), Bangalore, India, 5–7 March 2020; pp. 47–53.
31. Gauvain, J.-L.; Lee, C.-H. Maximum a posteriori estimation for multivariate Gaussian mixture observations of Markov chains. *IEEE Trans. Speech Audio Process.* **1994**, *2*, 291–298. [[CrossRef](#)]
32. Specht, D.F. Probabilistic neural networks. *Neural Netw.* **1990**, *3*, 109–118. [[CrossRef](#)]
33. Keyrouz, F.; Georges, S. Efficient multidimensional Maximum Power Point Tracking using Bayesian fusion. In Proceedings of the 2011 2nd International Conference on Electric Power and Energy Conversion Systems (EPECS), Sharjah, United Arab Emirates, 15–17 November 2011; pp. 1–5.
34. Ali, H.G.; Arbos, R.V.; Herrera, J.; Tobón, A.; Peláez-Restrepo, J. Non-Linear Sliding Mode Controller for Photovoltaic Panels with Maximum Power Point Tracking. *Processes* **2020**, *8*, 108. [[CrossRef](#)]
35. Pai, F.-S.; Chao, R.-M.; Ko, S.H.; Lee, T.-S. Performance Evaluation of Parabolic Prediction to Maximum Power Point Tracking for PV Array. *IEEE Trans. Sustain. Energy* **2010**, *2*, 60–68. [[CrossRef](#)]
36. Pai, F.-S.; Chao, R.-M. A New Algorithm to Photovoltaic Power Point Tracking Problems with Quadratic Maximization. *IEEE Trans. Energy Convers.* **2009**, *25*, 262–264. [[CrossRef](#)]

37. Jiang, L.L.; Maskell, D.L.; Patra, J. A novel ant colony optimization-based maximum power point tracking for photovoltaic systems under partially shaded conditions. *Energy Build.* **2013**, *58*, 227–236. [[CrossRef](#)]
38. Sundareswaran, K.; Vigneshkumar, V.; Sankar, P.; Simon, S.P.; Nayak, P.S.R.; Palani, S. Development of an Improved P&O Algorithm Assisted Through a Colony of Foraging Ants for MPPT in PV System. *IEEE Trans. Ind. Informatics* **2015**, *12*, 187–200. [[CrossRef](#)]
39. Nivetha, V.; Gowri, G.V. Maximum power point tracking of photovoltaic system using ant colony and particle swarm optimization algorithms. In Proceedings of the 2nd International Conference on Electronics and Communication Systems (ICECS), Coimbatore, India, 26–27 February 2015; pp. 948–952. [[CrossRef](#)]
40. Emerson, N.; Srinivasan, S. Integrating hybrid power source into islanded microgrid using ant colony optimization. In Proceedings of the International Conference on Advanced Computing and Communication Systems, Coimbatore, India, 5–7 January 2015; pp. 1–4. [[CrossRef](#)]
41. Jiang, L.L.; Maskell, D.L. A uniform implementation scheme for evolutionary optimization algorithms and the experimental implementation of an ACO based MPPT for PV systems under partial shading. In Proceedings of the IEEE Symposium on Computational Intelligence Applications in Smart Grid (CIASG), Orlando, FL, USA, 9–12 December 2014; pp. 1–8.
42. Besheer, A.H.; Adly, M. Ant colony system based PI maximum power point tracking for stand alone photovoltaic system. In Proceedings of the IEEE International Conference on Industrial Technology, Athens, Greece, 19–21 March 2012; pp. 693–698. [[CrossRef](#)]
43. Adly, M.; Besheer, A.H. An optimized fuzzy maximum power point tracker for stand alone photovoltaic systems: Ant colony approach. In Proceedings of the 7th IEEE Conference on Industrial Electronics and Applications (ICIEA), Singapore, 18–20 July 2012; pp. 113–119. [[CrossRef](#)]
44. Krishnan, G.S.; Satheesh, G.; Kinattingal, S.S.; Simon, S.P.; Nayak, P.S.R. MPPT in PV systems using ant colony optimisation with dwindling population. *IET Renew. Power Gener.* **2020**, *14*, 1105–1112. [[CrossRef](#)]
45. Nguyen, T.; Vo, D.N.; Truong, A.V. Cuckoo search algorithm for short-term hydrothermal scheduling. *Appl. Energy* **2014**, *132*, 276–287. [[CrossRef](#)]
46. Basha, C.H.H.; Bansal, V.; Rani, C.; Brisilla, R.M.; Odofin, S. Development of Cuckoo Search MPPT Algorithm for Partially Shaded Solar PV SEPIC Converter BT-Soft Computing for Problem Solving. In *Soft Computing for Problem Solving*; Springer: Singapore, 2020; pp. 727–736.
47. Yang, X.; Deb, S. Cuckoo Search via Lévy flights. In Proceedings of the World Congress on Nature & Biologically Inspired Computing (NaBIC), Coimbatore, India, 9–11 December 2009; pp. 210–214.
48. Yang, X.-S.; Deb, S. Multiobjective cuckoo search for design optimization. *Comput. Oper. Res.* **2013**, *40*, 1616–1624. [[CrossRef](#)]
49. Ahmed, J.; Salam, Z. A critical evaluation on maximum power point tracking methods for partial shading in PV systems. *Renew. Sustain. Energy Rev.* **2015**, *47*, 933–953. [[CrossRef](#)]
50. Ahmed, J.; Salam, Z. A Maximum Power Point Tracking (MPPT) for PV system using Cuckoo Search with partial shading capability. *Appl. Energy* **2014**, *119*, 118–130. [[CrossRef](#)]
51. Miyatake, M.; Inada, T.; Hiratsuka, I.; Zhao, H.; Otsuka, H.; Nakano, M. Control characteristics of a fibonacci-search-based maximum power point tracker when a photovoltaic array is partially shaded. In Proceedings of the 4th International Power Electronics and Motion Control Conference (IPEMC), Xi'an, China, 14–16 August 2004; pp. 816–821.
52. Ramaprabha, R.; Mathur, B.; Ravi, A.; Avenhika, S. Modified Fibonacci Search Based MPPT Scheme for SPVA Under Partial Shaded Conditions. In Proceedings of the 2010 3rd International Conference on Emerging Trends in Engineering and Technology, Goa, India, 19–21 November 2010; pp. 379–384.
53. Khan, S.U.; Yang, S.; Wang, L.; Liu, L. A Modified Particle Swarm Optimization Algorithm for Global Optimizations of Inverse Problems. *IEEE Trans. Magn.* **2015**, *52*, 1–4. [[CrossRef](#)]
54. Liu, Y.; Huang, S.; Huang, J.; Liang, W. A Particle Swarm Optimization-Based Maximum Power Point Tracking Algorithm for PV Systems Operating Under Partially Shaded Conditions. *IEEE Trans. Energy Convers.* **2012**, *27*, 1027–1035. [[CrossRef](#)]
55. Takano, H.; Asano, H.; Gupta, N. Application Example of Particle Swarm Optimization on Operation Scheduling of Microgrids BT-Frontier Applications of Nature Inspired Computation. Khosravy, M., Gupta, N., Patel, N., Senjyu, T., Eds.; Springer: Singapore, 2020; pp. 215–239.
56. Khare, A.; Rangnekar, S. A review of particle swarm optimization and its applications in Solar Photovoltaic system. *Appl. Soft Comput.* **2013**, *13*, 2997–3006. [[CrossRef](#)]
57. Alajmi, B.N.F.M.T.; Ahmed, K.H.; Finney, S.J.; Williams, B.W. Fuzzy-Logic-Control Approach of a Modified Hill-Climbing Method for Maximum Power Point in Microgrid Standalone Photovoltaic System. *IEEE Trans. Power Electron.* **2010**, *26*, 1022–1030. [[CrossRef](#)]
58. Patcharaprakiti, N.; Premrudeepreechacharn, S. Maximum power point tracking using adaptive fuzzy logic control for grid-connected photovoltaic system. *Renew. Energy* **2003**, *30*, 1771–1788. [[CrossRef](#)]
59. Syafaruddin; Karatepe, E.; Hiyama, T. Artificial neural network-polar coordinated fuzzy controller based maximum power point tracking control under partially shaded conditions. *IET Renew. Power Gener.* **2009**, *3*, 239–253. [[CrossRef](#)]
60. Algazar, M.M.; Al-Monier, H.; El-Halim, H.A.; Salem, M.E.E.K. Maximum power point tracking using fuzzy logic control. *Int. J. Electr. Power Energy Syst.* **2012**, *39*, 21–28. [[CrossRef](#)]

61. Larbes, C.; Cheikh, S.M.A.; Obeidi, T.; Zerguerras, A. Genetic algorithms optimized fuzzy logic control for the maximum power point tracking in photovoltaic system. *Renew. Energy* **2009**, *34*, 2093–2100. [[CrossRef](#)]
62. Ramaprabha, R.; Gothandaraman, V.; Kanimozhi, K.; Divya, R.; Mathur, B.L. Maximum power point tracking using GA-optimized artificial neural network for Solar PV system. In Proceedings of the 1st International Conference on Electrical Energy Systems, Chennai, India, 3–5 January 2011; pp. 264–268. [[CrossRef](#)]
63. Mellit, A.; Benghanem, M.; Kalogirou, S. Modeling and simulation of a stand-alone photovoltaic system using an adaptive artificial neural network: Proposition for a new sizing procedure. *Renew. Energy* **2007**, *32*, 285–313. [[CrossRef](#)]
64. Punitha, K.; Devaraj, D.; Sakthivel, S. Artificial neural network based modified incremental conductance algorithm for maximum power point tracking in photovoltaic system under partial shading conditions. *Energy* **2013**, *62*, 330–340. [[CrossRef](#)]
65. Veerachary, M.; Senjyu, T.; Uezato, K. Neural-network-based maximum-power-point tracking of coupled-inductor interleaved-boost-converter-supplied pv system using fuzzy controller. *IEEE Trans. Ind. Electron.* **2003**, *50*, 749–758. [[CrossRef](#)]
66. Khaitan, S.K.K.; Gopalakrishnan, K.; Kalogirou, S. (Eds.) *Soft Computing in Green and Renewable Energy Systems*; Springer: Berlin/Heidelberg, Germany, 2011.
67. Leyva, R.; Olalla, C.; Zazo, H.; Cabal, C.; Cid-Pastor, A.; Queinnec, I.; Alonso, C. MPPT Based on Sinusoidal Extremum-Seeking Control in PV Generation. *Int. J. Photoenergy* **2012**, *2012*, 672765. [[CrossRef](#)]
68. Brunton, S.L.; Rowley, C.W.; Kulkarni, S.R.; Clarkson, C. Maximum Power Point Tracking for Photovoltaic Optimization Using Ripple-Based Extremum Seeking Control. *IEEE Trans. Power Electron.* **2010**, *25*, 2531–2540. [[CrossRef](#)]
69. Heydari-Doostabad, H.; Keypour, R.; Khalghani, M.R.; Khooban, M.H. A new approach in MPPT for photovoltaic array based on Extremum Seeking Control under uniform and non-uniform irradiances. *Sol. Energy* **2013**, *94*, 28–36. [[CrossRef](#)]
70. Zhou, L.; Chen, Y.; Guo, K.; Jia, F. New Approach for MPPT Control of Photovoltaic System with Mutative-Scale Dual-Carrier Chaotic Search. *IEEE Trans. Power Electron.* **2011**, *26*, 1038–1048. [[CrossRef](#)]
71. Zhou, L.; Chen, Y.; Liu, Q.; Wu, J. Maximum power point tracking (MPPT) control of a photovoltaic system based on dual carrier chaotic search. *J. Control. Theory Appl.* **2012**, *10*, 244–250. [[CrossRef](#)]
72. Taheri, H.; Salam, Z.; Ishaque, K.; Syafaruddin. A novel Maximum Power Point tracking control of photovoltaic system under partial and rapidly fluctuating shadow conditions using Differential Evolution. In Proceedings of the IEEE Symposium on Industrial Electronics and Applications (ISIEA), Penang, Malaysia, 3–5 October 2010; pp. 82–87. [[CrossRef](#)]
73. da Costa, W.T.; Fardin, J.F.; Simonetti, D.S.L.; Neto, L.D.V.B.M. Identification of photovoltaic model parameters by Differential Evolution. In Proceedings of the 2010 IEEE International Conference on Industrial Technology, Via del Mar, Chile, 14–17 March 2010; pp. 931–936. [[CrossRef](#)]
74. Kulaksız, A.A.; Akkaya, R. A genetic algorithm optimized ANN-based MPPT algorithm for a stand-alone PV system with induction motor drive. *Sol. Energy* **2012**, *86*, 2366–2375. [[CrossRef](#)]
75. Liu, L.; Liu, C. A Novel Combined Particle Swarm Optimization and Genetic Algorithm MPPT Control Method for Multiple Photovoltaic Arrays at Partial Shading. *J. Energy Resour. Technol.* **2012**, *135*, 012002. [[CrossRef](#)]
76. Ali, A.; Wang, Y.; Li, W.; He, X. Implementation of simple moving voltage average technique with direct control incremental conductance method to optimize the efficiency of DC microgrid. In Proceedings of the International Conference on Emerging Technologies (ICET), Peshawar, Pakistan, 19–20 December 2015; pp. 1–5.
77. Ali, A.; Li, W.; He, X. Performance Analysis of Incremental Conductance MPPT with Simple Moving Voltage Average Method for Distributed PV System. *Open Electr. Electron. Eng. J.* **2016**, *10*, 118–128. [[CrossRef](#)]
78. Stanimirović, P.S.; Petković, M.D. Improved GNN Models for Constant Matrix Inversion. *Neural Process. Lett.* **2019**, *50*, 321–339. [[CrossRef](#)]
79. Shmilovitz, D. On the control of photovoltaic maximum power point tracker via output parameters. *IEE Proc. Electr. Power Appl.* **2005**, *152*, 239–248. [[CrossRef](#)]
80. Uoya, M.; Koizumi, H. A Calculation Method of Photovoltaic Array's Operating Point for MPPT Evaluation Based on One-Dimensional Newton–Raphson Method. *IEEE Trans. Ind. Appl.* **2014**, *51*, 567–575. [[CrossRef](#)]
81. Yu, M.Q. Parameter Identification of Photovoltaic Cell Model Based on Perturbation and Observation and Modified Gauss-Newton Method. In Proceedings of the 2018 37th Chinese Control Conference (CCC), Wuhan, China, 25–27 July 2018. [[CrossRef](#)]
82. Bhukya, L.; Nandiraju, S. A novel photovoltaic maximum power point tracking technique based on grasshopper optimized fuzzy logic approach. *Int. J. Hydrog. Energy* **2020**, *45*, 9416–9427. [[CrossRef](#)]
83. Yang, B.; Zhong, L.; Zhang, X.; Shu, H.; Yu, T.; Li, H.; Jiang, L.; Sun, L. Novel bio-inspired memetic salp swarm algorithm and application to MPPT for PV systems considering partial shading condition. *J. Clean. Prod.* **2019**, *215*, 1203–1222. [[CrossRef](#)]
84. Yang, B.; Yu, T.; Zhang, X.; Li, H.; Shu, H.; Sang, Y.; Jiang, L. Dynamic leader based collective intelligence for maximum power point tracking of PV systems affected by partial shading condition. *Energy Convers. Manag.* **2018**, *179*, 286–303. [[CrossRef](#)]
85. Eusuff, M.; Lansey, K.; Pasha, F. Shuffled frog-leaping algorithm: A memetic meta-heuristic for discrete optimization. *Eng. Optim.* **2006**, *38*, 129–154. [[CrossRef](#)]
86. Jiang, M.; Ghahremani, M.; Dadfar, S.; Chi, H.; Abdallah, Y.N.; Furukawa, N. A novel combinatorial hybrid SFL–PS algorithm based neural network with perturb and observe for the MPPT controller of a hybrid PV-storage system. *Control. Eng. Pr.* **2021**, *114*, 104880. [[CrossRef](#)]