

Electric vehicle energy consumption modelling and estimation—A case study

Ilyès Miri¹ | Abbas Fotouhi¹  | Nathan Ewin²

¹School of Aerospace, Transport and Manufacturing, Cranfield University, Cranfield, UK

²Delta Motorsport Ltd, Silverstone, UK

Correspondence

Abbas Fotouhi, School of Aerospace, Transport and Manufacturing, Cranfield University, College Road, Cranfield, Bedford, MK43 0AL, UK.

Email: a.fotouhi@cranfield.ac.uk

Summary

Electric vehicles (EVs) have a limited driving range compared to conventional vehicles. Accurate estimation of EV's range is therefore a significant need to eliminate “range anxiety” that refers to drivers' fear of running out of energy while driving. However, the range estimators used in the currently available EVs are not sufficiently accurate. To overcome this issue, more accurate range estimation techniques are investigated. Nonetheless, an accurate power-based EV energy consumption model is crucial to obtain a precise range estimation. This paper describes a study on EV energy consumption modelling. For this purpose, EV modelling is carried out using MATLAB/Simulink software based on a real EV in the market, the BMW i3. The EV model includes vehicle powertrain system and longitudinal vehicle dynamics. The powertrain is modelled using efficiency maps of the electric motor and the power electronics' data available for BMW i3. It also includes a transmission and a battery model (ie, Thevenin equivalent circuit model). A driver model is developed as well to control the vehicle's speed and to represent human driver's behaviour. In addition, a regenerative braking strategy, based on a series brake system, is developed to model the behaviour of a real braking controller. Auxiliary devices are also included in the EV model to improve energy consumption estimation accuracy as they can have a significant impact on that. The vehicle model is validated against published energy consumption values that demonstrates a satisfactory level of accuracy with 2% to 6% error between simulation and experimental results for Environmental Protection Agency and NEDC tests.

KEYWORDS

battery, electric vehicle, energy consumption estimation, modelling, simulation

Abbreviations: AC, Alternative Current; ANN, Artificial Neural Network; DC, Direct Current; ECN, Equivalent Circuit Network; EPA, Environmental Protection Agency; EU, European Union; EV, Electric Vehicle; EVs, Electric Vehicles; FTP-75, Federal Test Procedure-75; GPS, Global Positioning System; HWFET, Highway Fuel Economy Test; Li-ion, Lithium-ion; MLR, Multiple Linear Regression; NEDC, New European Driving Cycle; PCA, Principal Component Analysis; PI, Proportional-Integral; PID, Proportional-Integral-Derivative; REx, Range Extender; RWD, Rear-Wheel-Drive; SoC, State-of-Charge; SoH, State-of-Health; US, United-States; WLTP, Worldwide Harmonised Light Vehicle Test Procedure.

This is an open access article under the terms of the Creative Commons Attribution License, which permits use, distribution and reproduction in any medium, provided the original work is properly cited.

© 2020 The Authors. *International Journal of Energy Research* published by John Wiley & Sons Ltd

1 | INTRODUCTION

Global warming and environmental pollution have led to more severe regulations on CO₂ and other pollutant emissions. In this context, electric vehicles (EVs) have become an alternative to conventional vehicles as they offer a zero-emission alternative. Besides, they are cheaper to be recharged as electricity is cheaper than petrol/diesel and also energy recovery is possible from regenerative braking in EVs.

However, the EVs' market penetration rate is not very quick because of their limited range, charging time, battery replacement cost, and other limitations related to infrastructure. This study is particularly related to one of these restrictions, the limited EV range. This limitation causes an issue called "range anxiety" that refers to drivers' fear of running out of energy while driving.¹ This phenomenon can be limited by increasing the battery capacity and/or the number of charging stations. However, both solutions are expensive, and will not improve the confidence of drivers in the remaining driving range estimation. Nowadays, range estimators are not sufficiently accurate because they are mainly based on vehicle historical data. Thus, they can lead to major estimation errors and cannot be fully trusted by drivers. "Range anxiety" can be reduced by improving the range estimation to increase drivers' confidence. For EV range estimation, an accurate estimation of the EV's energy consumption is vital and is therefore the purpose of this study.

In this study, the energy flow is only considered inside the vehicle so, the energy flow between the grid and vehicle is out of the framework. Generally, the EV energy consumption refers to the sum of:

- Energy that is required at the wheels to propel the vehicle,
- Energy losses along the powertrain, and
- Energy that is required for the operation of the auxiliary devices.

New techniques are required for more accurate EV energy consumption/range estimation aiming to reduce "range anxiety" and increase the driving range. In fact, higher range can be achieved by giving more confidence to the drivers, enabling them to extend the use of their vehicle on a single charge. This idea comes from knowing that nowadays, most of the drivers only use about 70% of the estimated remaining battery energy due to a lack of confidence.²

In this study, EV energy consumption estimation is the main focus and it is performed based on vehicle modelling using MATLAB/Simulink software. The BMW i3 is selected as the case-study here to demonstrate the

proposed concept. The authors believe that same technique can be applied to other types of EV and the general outcomes of this study do not depend on the vehicle type used here. As an important part of this study, the proposed vehicle model is validated against experimental data obtained from the literature.

Two main approaches are used for EV modelling³: (a) Forward approach also called "dynamic approach" or cause-effect method, and (b) Backward approach also called "quasi-static approach" or effect-cause method. The forward approach is based on equations of the powertrain components behaviour and the dynamic interaction between the components. This approach requires a driver controller to set the start of the calculations. Therefore, the driver behaviour can be studied using this approach. The controller is implemented to model the driver that has to press/release either the accelerator or the brake pedal in order to reduce the error between the actual speed and the speed from a drive cycle.⁴ The driver model provides the torque demand to match the drive cycle speed profile. Thereafter, from the driver set-point, the energy required to overcome the opposing forces acting on the vehicle is computed. The backward approach considers a reference speed profile, as input, to determine the forces acting at the wheels and then processes backward through the powertrain. Subsequently, the model computes the motor torque and the energy required from the battery to power the electric motor.⁴ The advantages of the forward method are that the driving speed profile does not need to be known⁵ and that it can be easily and rapidly used for prototyping and hardware in the loop testing.⁶ Besides, it is suitable to identify the interactions between components that can affect the energy consumption and the performance of the vehicle. Even though it requires more computational effort to solve the model's differential equations, the forward approach is more accurate than the backward approach.⁴

Vehicle energy consumption is affected by several factors that can be divided into two main categories^{7,8}: (a) Internal Factors associated with the vehicle itself (vehicle design parameters, characteristics, efficiency and inertia of the vehicle components, auxiliary devices usage, etc.), and (b) External Factors associated with driving conditions (environmental and traffic conditions, road type and conditions, driving behaviour, etc.). To develop an accurate EV energy consumption estimation model, the impact of all factors must be carefully examined because road slope, for instance, has a major impact on that.⁹ The external factors demonstrates different level of variability with regard to real world driving conditions. Depending on their variability and their predictability, they are classified in three categories^{10,11}: Stable, Dynamic but easy to predict and Dynamic and difficult to predict.

For range estimation, most of the car manufacturers use an approach based on analysis of a short history of energy consumption to predict it in the near future. In that method, it is assumed that the rate of energy consumption remains unchanged in a short prediction horizon. However, this approach is not accurate since it does not consider the changes in driving conditions that may occur.¹⁰ EV energy consumption estimation models can be classified in three main categories: Analytical, Statistical and Computational models.⁷

Analytical models work based on longitudinal vehicle dynamics and electric motor losses estimation from available efficiency maps.^{2,12,13} Longitudinal vehicle dynamics is modelled from the vehicle dynamics theory to calculate the required power at the wheels to overcome the opposing forces. In some studies, the regenerative braking is modelled as a linear function of vehicle speed to estimate the energy recovered while braking or driving downhill² or it is modelled as a function of vehicle deceleration.¹² The model developed in Reference 12 considers the instantaneous EV speed and acceleration to provide an accurate second-by-second energy consumption estimation. Contrary to,² the model not only considers the motor efficiency but also the efficiency of other powertrain components. The impact of auxiliary devices is considered as well for an improved estimation.¹² The model introduced in Reference 13 expresses the relationship between EV power, speed, acceleration and road grade to determine the required power at the wheels. The model can be either used for instantaneous energy consumption estimation or energy consumption prediction over a trip for eco-route planning.¹³ The existing regenerative braking models are improved in this study by considering the limitations coming from the battery and the electric motor.

Statistical models are based on the analysis of real-world driving data to derive empirical relationships between different factors and EV's energy consumption. For this purpose, regression models that consider both EV dynamic behaviour and powertrain efficiency, have been developed.¹⁴⁻¹⁶ For example, the model developed in Reference 14, works based on historical and real-time data analysis in order to derive polynomial combinations of EV speed, acceleration and battery State-of-Charge (SoC) under different operation modes. In Reference 15, three regression models using multiple linear regression (MLR) method, have been developed with different levels of detail. Road characteristics, traffic conditions, driving style and environmental conditions are well considered to update the estimation models for an improved accuracy. The first model is used for energy consumption estimation over a trip for route planning and does not consider weight variation and acceleration, assuming constant EV speed. It is improved with a second model

that includes acceleration data while a third model is proposed for instantaneous energy consumption estimation while driving.¹⁵ In Reference 16 an improved MLR energy consumption model based on the extraction of real-world data and speed profile prediction using Neural Networks is presented. That model also considers the energy consumption of auxiliary devices. The proposed model performs well even in the existence of changes in driving behaviour and environmental conditions.¹⁶ Furthermore, Principal Component Analysis (PCA) is used in Reference 7 to study the impact of each factor separately. PCA consists of transforming a set of correlated variables into a set of new uncorrelated variables using an orthogonal transformation. The EV energy consumption is then estimated as a polynomial combination of each variable weighted depending on its relative importance.⁷ Statistical models demonstrate a good applicability since they require less computational effort than analytical models however, they are less accurate.

Computational models based on artificial neural networks (ANN) are developed to determine relationships between a number of affecting factors and EV energy consumption.^{7,17,18} This type of models are used to estimate EV energy consumption as a function of the input factors, where a weight is determined for each factor depending on its relative importance using training algorithms.¹⁷ This approach performs well in fitting nonlinear relationships between input and output variables.⁷ ANN can also be used for prediction of driving behaviour by classifying driving patterns using Global Positioning System data. This method is found to be a powerful approach as it is data-driven and self-adaptive.¹⁸ As part of this method, clustering techniques are used to recognize similar patterns in a set of data in order to gather data with similar properties.¹⁹⁻²³ It is applicable to driving pattern recognition and driving behaviour analysis which is used to improve the accuracy of energy consumption estimation models.²⁴ The computational models found in the literature do not take into account all the factors affecting the energy consumption such as auxiliary devices that can affect significantly the vehicle energy consumption.

The selection of an estimation approach depends on the targeted application. In general, statistical and computational models require more computational effort than analytical models. However, they are more accurate as they work based on data analysis and probabilistic prediction. In addition, analytical models can only reflect changes in vehicle behaviour as they are based on vehicle dynamics and physical modelling. Using analytical models, it is difficult to take into account factors associated with driving conditions such as environmental and traffic conditions.¹⁰ However, some hybrid methods that are both physics-based and data-driven have been developed in References

25 and 26. In Reference 26, a simulation tool called “Autonomie” is described that is developed by Argonne National Laboratory. That simulation tool works based on vehicle parameters and data analysis and it is used for vehicle energy consumption calculation. Autonomie has demonstrated good accuracy against test data and is widely used by the industry. Such hybrid methods combine the advantages of both analytical and data-driven models.

Energy consumption estimation models can be used for various applications:

- Estimation before a trip for route planning as part of an eco-routing system. For a targeted destination, the system determines the best route by minimising the energy consumption based on the current traffic and environmental conditions.⁷
- Estimation second-by-second to provide dynamic information about the vehicle energy consumption.
- Eco Approach and Departure application to provide recommendations to reduce the energy consumption when approaching signalised intersections. Examples are calculating the optimum speed to reach the next traffic signal on a green light or to come to a stop in the most efficient way and display it to the driver.²⁷

In this study, a model-based EV energy consumption estimator is proposed and validated for a case-study on BMW i3. For this purpose, a forward EV powertrain model is developed using MATLAB/Simulink software. The proposed model considers the power consumption of auxiliary devices in contrast to the work presented in Reference 2. The power consumption of auxiliary devices is estimated from average values found in the literature, which is discussed in this paper. This estimation is included in the EV model since auxiliary devices can have a significant impact on the vehicle energy consumption. In addition, the efficiency values of power electronics and electric motor are estimated from the efficiency maps whereas they are assumed to be constant in previous studies such as the work performed in Reference 28. The efficiency values are interpolated over the entire range of the electric motor using efficiency maps available in the literature. Furthermore, the regenerative braking strategy that is modelled in this study works based on the series brake system configuration used on the BMW i3. This strategy considers several factors affecting the regenerative braking capability of the EV such as vehicle speed, acceleration and battery SoC. As a consequence, the braking strategy tends to be more accurate than previous models developed for example in References 2 and 12.

Summarising the aforementioned literature, the novelties of this study are as follows:

- Estimation of the power consumption of auxiliary devices.
- Estimation of the efficiency of electric motor and inverter from efficiency maps.
- Precise modelling of a regenerative braking strategy currently used on the market.

Unlike conventional vehicles, the range of EVs is limited even if the battery capacity has been increased in the newly available vehicles. Therefore, the use of highly precise range estimators is still a major issue in EVs. However, the current range estimators work on the basis of vehicle’s historical data analysis and are therefore not very accurate. For range estimation, an accurate model of the EV’s energy consumption is essential. Such a model can be implemented in EV range estimators to assess the energy consumption of any EV model.

The main objective of this paper is to introduce an accurate modelling approach for EV energy consumption estimation. In order to demonstrate the proposed concept and validate the results, a case-study on BMW i3 has been chosen as a typical EV in the market. So, the goal is to model the target EV including its powertrain system and longitudinal dynamics and then validate it using the available data.

2 | VEHICLE MODELLING

Architecture of the EV energy consumption estimation model, developed in this study, is presented in Figure 1. The consumed energy, E_{cons} , is calculated as per unit of distance (Wh/m) derived from the battery power output P_{bat} ²⁹:

$$E_{\text{cons}} = \frac{E_{\text{bat}}}{d}, \quad (1)$$

$$E_{\text{bat}} = \left(\int_{\text{traction}} P_{b-\text{out}}(\tau) d\tau - \int_{\text{braking}} P_{b-\text{in}}(\tau) d\tau \right) \cdot \frac{1}{3600}, \quad (2)$$

$$P_{b-\text{out}} = \frac{R_{\text{Total}} \cdot V_{\text{Vehicle}}}{\eta_{\text{Powertrain}}} \text{ and } P_{b-\text{in}} = \alpha \cdot P_{\text{regen}}, \quad (3)$$

where E_{bat} is the battery energy output in (Wh), d is the distance travelled in (m), R_{Total} is the total resistance forces opposed to the vehicle motion in (N), V_{Vehicle} is the vehicle speed in (m/s), $\eta_{\text{Powertrain}}$ is powertrain efficiency (including power electronics, electric motor and transmission), α is the percentage of the braking energy that can be recovered ($0 < \alpha < 1$), that is also called regenerative braking factor and P_{regen} is the regenerative power that is calculated based on $X_{B_{\text{Regen}}}$ and motor’s limitations as follows:

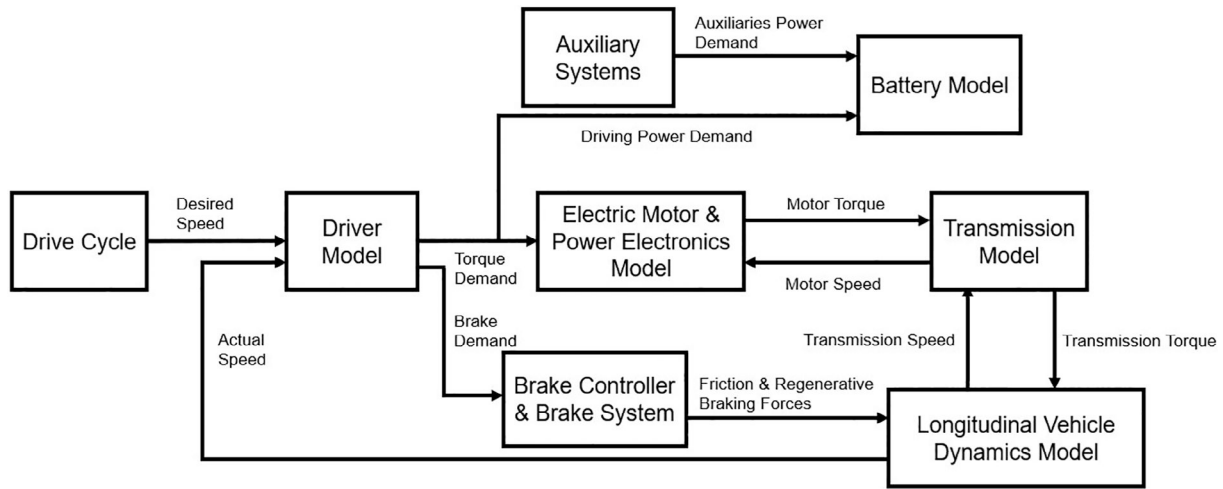

FIGURE 1 Forward electric vehicle model architecture

$$T_{Br_demanded} = \frac{X_{B_{Regen}} \cdot r_d}{G \cdot \eta_G}, \quad (4)$$

$$P_{Br_demanded} = T_{Br_demanded} \cdot \omega_{motor(s)}, \quad (5)$$

P_{b-out} and P_{b-in} are respectively the power provided by the battery for vehicle motion and the power regenerated to charge the battery considering electric motor braking capabilities in generator mode.

As aforementioned, the battery power output P_{bat} is divided into two main parts:

- Power that is used to propel the vehicle (P_{b-out}): the battery must supply this power to overcome the opposing forces and any power losses along the powertrain system (Power out).
- Power that is regenerated during braking (P_{b-in}): part of the braking energy can be recovered from regenerative braking by operating the motor in generator mode and charging the battery (Power in).

In the following sections, individual components of the proposed model are explained in more details. In order to simulate the model, numerical values of BMW i3 are used as a popular EV in the market. The proposed model is then validated against the available data for that particular EV.

2.1 | Vehicle specifications

The 2014 BMW i3 60Ah Range Extender (REx) is considered to be modelled as a case-study. For simplicity, the REx is not modelled since it is only used for battery SoC below 6%.³⁰ The vehicle model is therefore applicable

for SoC level above 6% which is sufficient for the proof of concept in this study. BMW i3 is a rear wheel drive (RWD) EV with one electric motor at the rear axle. The power transmission between the motor and the wheels is achieved by a single-speed automatic transmission system. The vehicle specifications are presented in Table 1. In addition, the efficiency maps of the inverter and the electric motor that are used in the BMW i3, are shown in Figure 2. The torque and power curves of the electric motor are also shown in the same figure.

2.2 | Vehicle model

Since this study aims at EV energy consumption estimation, only the powertrain system and the longitudinal vehicle dynamics are modelled. The lateral dynamics is neglected as it does not have a major impact on vehicle's energy consumption. Three main power flows are considered in the proposed model:

- Energy flow from the battery pack to the wheels to propel the vehicle.
- Energy flow from the wheels to the battery pack during energy recovery by regenerative braking.
- Energy flow from the battery pack to the auxiliary systems via the 12 V battery.

The vehicle model is developed in MATLAB/Simulink and consists of a combination of different subsystems listed in below:

- Driving cycle subsystem including the reference speed that vehicle must follow. This subsystem is the input of the model.

TABLE 1 2014 BMW i3 60Ah Range Extender specifications³¹⁻³³

VEHICLE BODY		
Curb weight (EU)	1390	kg
Curb weight (US)	1420	kg
Aerodynamic drag coefficient	0.3	
Frontal area	2.38	m ²
Wheelbase	2570	mm
Static weight distribution (empty car)	44.9/55.1	Front %/Rear %
Drivetrain	Rear wheel drive (RWD)	
POWERTRAIN		
Number of motor(s)	1	
Motor type	Permanent magnet AC synchronous electric motor (BMW hybrid synchronous motor)	
Motor operating range	0-11 400	rpm
Maximum power/at rpm	125/4775	kW/rpm
Maximum torque/at rpm	250/0-4475	Nm/rpm
Maximum regenerative brake power	55	kW
TRANSMISSION		
Type	Single-speed automatic transmission	
Simple fixed gear ratio	9.7:1	
Tyres model	Bridgestone Ecopia EP600	
Front/rear tyres size	175/70 R19	
Front/rear tyres radius	0.3638	m
BATTERY		
Chemistry	Lithium-ion	
Battery configuration	8 Modules (96 Cells Connected in Series)	
Nominal cell voltage	3.7	V
Nominal cell capacity	60	Ah
Nominal battery pack voltage	355.2	V
Nominal battery pack capacity	60	Ah
Nominal battery pack energy	22	kWh
PERFORMANCE		
Top speed	150	km/h
Acceleration (0-100 km/h)	7.9	s
Driving modes	Comfort Eco Pro Eco Pro +	
Electric range (NEDC)	170	km
Electric range (EPA combined)	115	km
Energy consumption (NEDC)	13.5	kWh/100 km
Energy consumption (EPA combined)	117	mpge
	29	kWh/100mi

Abbreviations: EPA, Environmental Protection Agency; NEDC, New European Driving Cycle.

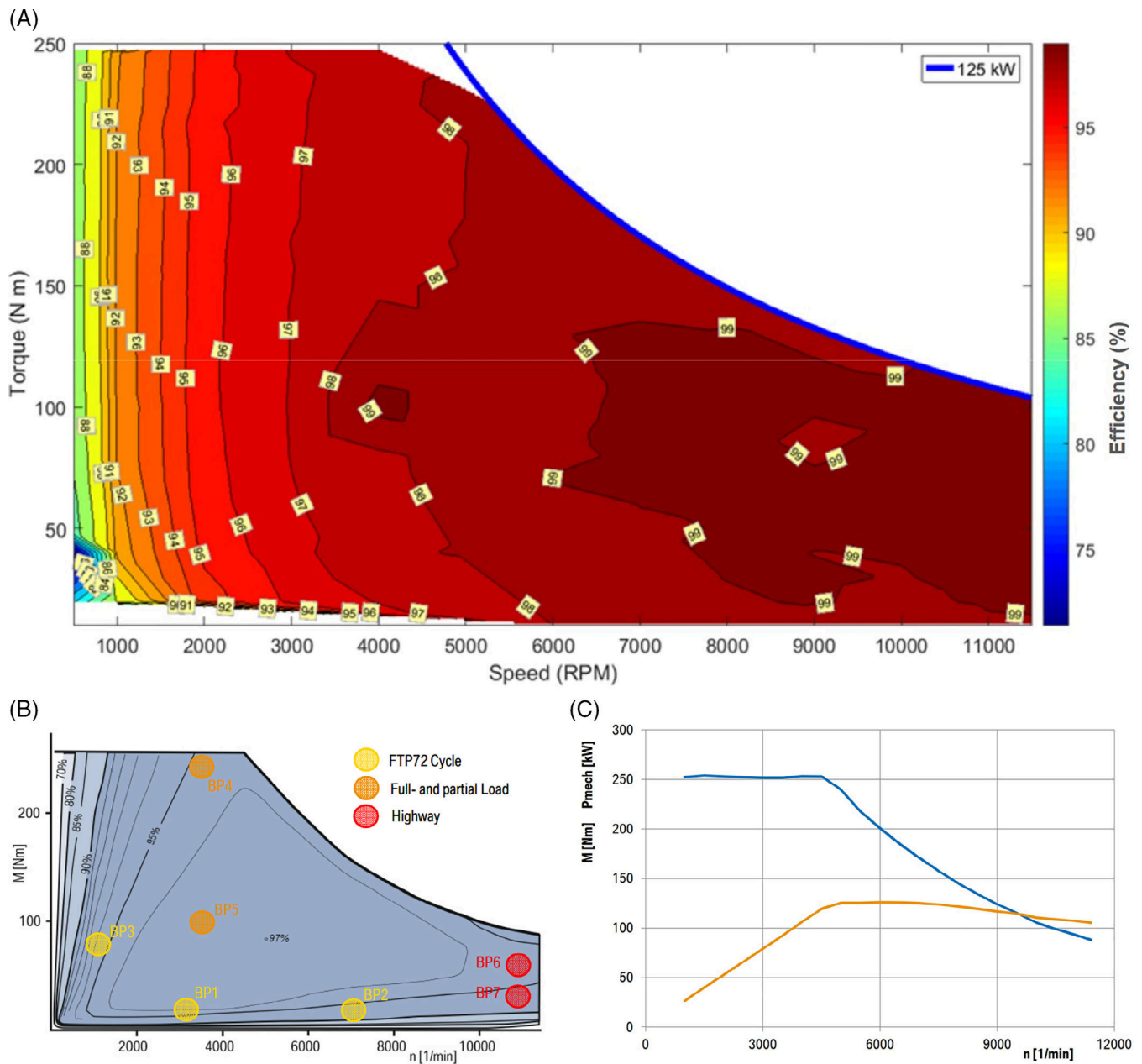

FIGURE 2 A, BMW i3 inverter efficiency map,³⁴ B. electric motor efficiency map, and C. electric motor torque and power curves³⁵ [Colour figure can be viewed at wileyonlinelibrary.com]

- Driver model that is responsible for controlling the vehicle motion by providing accelerator and brake commands in the model.
- Brake system and the controller that is designed for distributing the braking force/torque demand between friction and regenerative brakes.
- Electric motor and inverter model for computing the energy losses by considering the efficiency of the motor and the inverter.
- Transmission model for calculating the tractive force by considering the energy losses while transmitting the torque from the motor to the driving wheels.
- Battery subsystem that is designed to calculate energy demand from the battery pack by considering the limitations of battery in terms of voltage and current boundaries.
- Auxiliary subsystem that is designed to calculate the power demand from auxiliary devices.

- Longitudinal vehicle dynamics subsystem to calculate the opposing forces and to update vehicle's velocity at each simulation time step.

Figure 3 illustrates the whole vehicle model including all the above-mentioned subsystems and interactions between them. In the following sections, individual subsystems are explained with more details.

2.2.1 | Driver model

The driver model aims to represent a human driver's behaviour in the most realistic possible way. However, driving behaviour is a difficult phenomenon to be modelled because it depends on subjective factors such as driver's physical conditions and mood. In this study, a simplified driver model is considered which is just responsible to minimise the error (ΔV) between the drive cycle (reference desired speed, $V_{desired}$) and the actual vehicle's speed (V_{actual}). Depending on the sign of ΔV , driver's acceleration or brake command is generated to make the vehicle to follow the reference speed profile. When ΔV is positive, an acceleration command (D_A) is generated, meaning that the driver must press the accelerator pedal to increase vehicle's speed. On the other hand, when ΔV is negative, a brake command (D_B) is generated. In that situation, the driver has two options, either press the brake pedal to brake the vehicle using the frictions brakes or release only the accelerator pedal to slow down the vehicle by dynamic braking. The choice between one of these two options depends on the braking strategy.

As shown in Figure 4, the proposed driver model consists of two subsystems: (a) the driver controller, and (b) accelerator and brake commands. PID controllers are the most widely used controllers at industry as they are easy to be implemented. Besides, PI controllers have been found to be widely used for driver modelling in several previous studies. Therefore, a PI controller is chosen to model the driver in this study, as follows:

$$PI(s) = \left(P + I \cdot \frac{1}{s} \right), \tag{6}$$

where P and I are proportional and integral gains respectively. The driver's pedal command taken splits into brake and accelerator commands according to its sign as shown in Figure 4. The driver's command is scaled between -100 and 100% corresponding to fully pressed brake pedal and fully pressed accelerator pedal respectively. Both commands are then normalized between 0 and 1 , corresponding to fully released and fully pressed pedal respectively.

In order to tune the PI controller's gains, New European Driving Cycle (NEDC) simulation case-studies are performed. During real drive cycle tests, the test driver must follow a reference speed profile such as NEDC with maximum 2 km/h error.³⁶ Therefore, to get a similar behaviour to a human driver from the model, a maximum allowed deviation of 2 km/h (± 2 km/h) is considered in the simulations as well. The PI controller is therefore tuned according to the aforementioned criterion. A sensitivity analysis is also conducted as shown in Table 2. From this analysis, it can be concluded that when the controller's gains are changed, the energy consumption

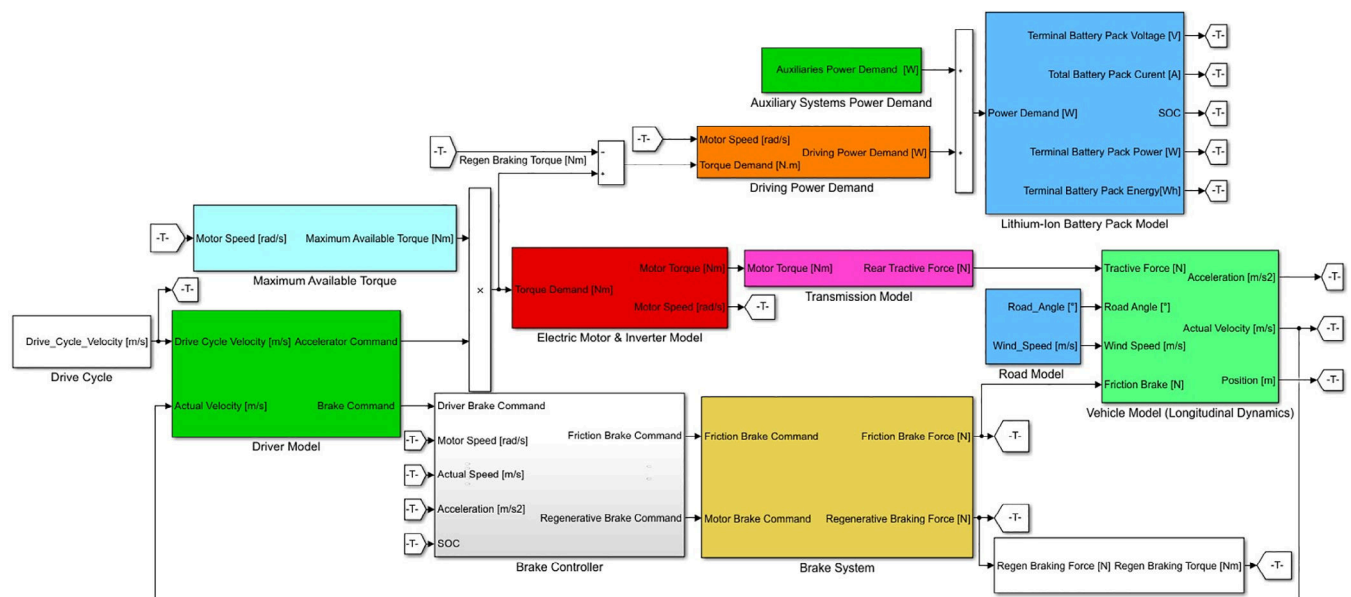

FIGURE 3 BMW i3 model in MATLAB/Simulink [Colour figure can be viewed at wileyonlinelibrary.com]

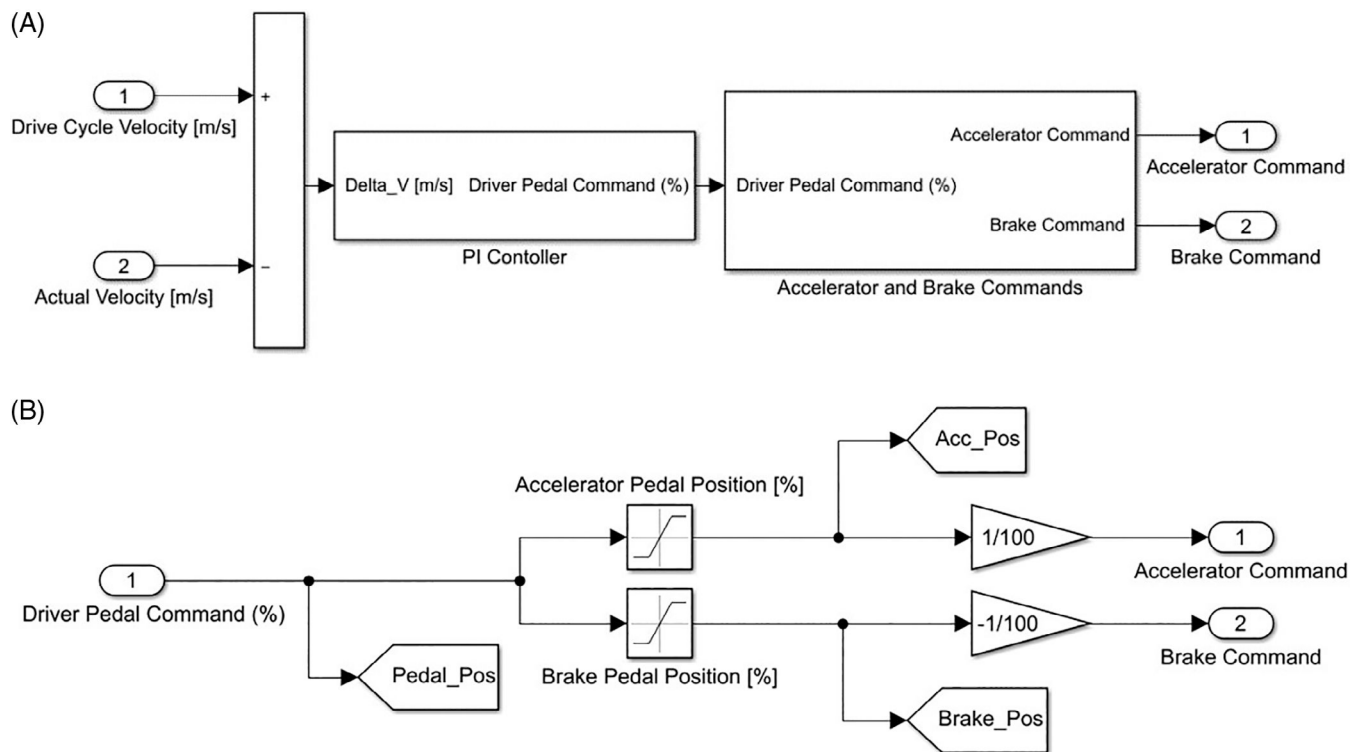

FIGURE 4 A, Driver model and B, driver accelerator and brake commands subsystem in Simulink

TABLE 2 Driver controller sensitivity analysis

Tuning setup	Distance (km)	Energy consumption (Wh/km)	Maximum speed error (+) (km/h)	Maximum speed error (–) (km/h)
P = 10 and I = 1	11.02	129.44	7.15	–8.35
P = 60 and I = 1	11.02	126.97	1.36	–1.57
P = 60 and I = 2	11.02	127.64	1.42	–1.52
P = 100 and I = 1	11.02	127.12	0.86	–0.95

varies slightly while the variation of the speed error is substantial. As a result, because the actual vehicle speed must remain in the allowable range (± 2 km/h) the controller parameters are chosen as follows: $P = 60$ and $I = 2$. Reference velocity, actual vehicle velocity and the error between them are demonstrated in Figure 5 for NEDC simulation case-study.

2.2.2 | Braking strategy model

In EVs, dynamic braking by the electric motor enables recharging the battery while driving. In order to estimate the braking force required to slow down the vehicle, the maximum available braking force X_{BMAX} must be determined, which depends on the normal load acting on the

vehicle and the adhesion between the tyres and the road^{29,37}:

$$X_{BMAX} = \varphi \cdot (Z_f + Z_r) = \varphi \cdot M_{\text{Vehicle}} \cdot g, \quad (7)$$

where φ is the adhesion coefficient between the tyres and the road, Z_f and Z_r are the normal loads on front and rear axles in (N) respectively, M_{Vehicle} is the vehicle mass in (kg) and g is the acceleration due to gravity in (m/s^2). Typical values of φ are around 0.8 on dry or wet asphalt and concrete surfaces.²⁹ In the proposed EV model, the braking force is distributed between the friction and regenerative brakes as follows:

$$X_{B\text{Friction}} = X_{BMAX} \cdot D_{B\text{Friction}}, \quad (8)$$

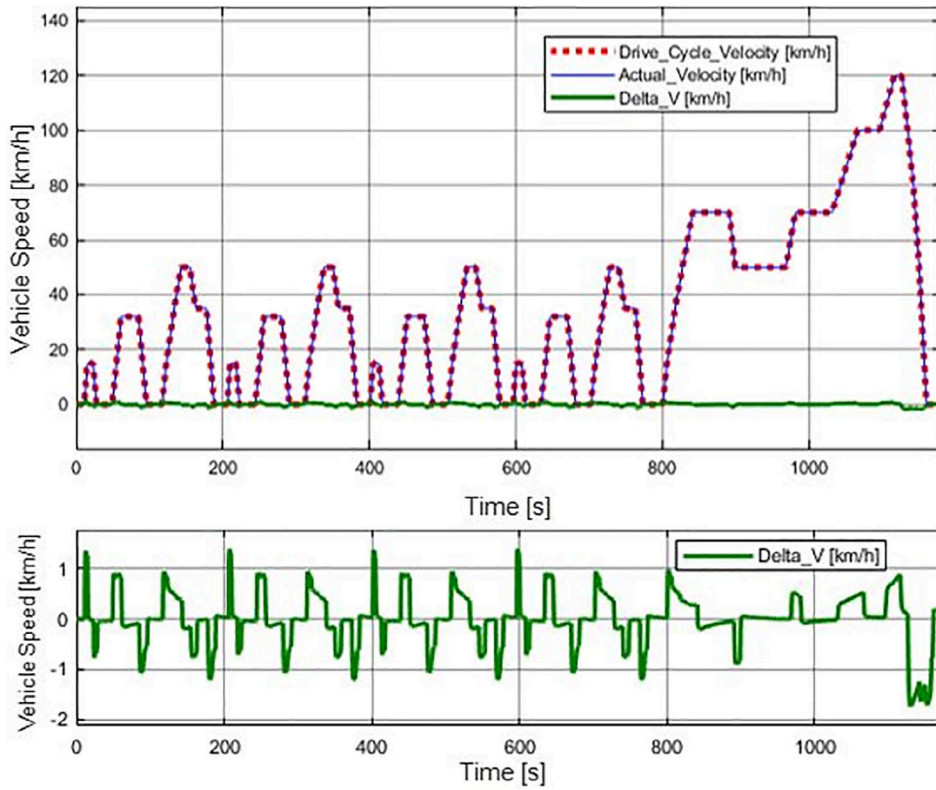

FIGURE 5 Reference and actual speed profiles on the New European Driving Cycle [Colour figure can be viewed at wileyonlinelibrary.com]

$$X_{B_{\text{Regen}}} = X_{B_{\text{MAX}}} \cdot D_{B_{\text{Regen}}}, \quad (9)$$

where $X_{B_{\text{Friction}}}$ and $X_{B_{\text{Regen}}}$ are the friction and the regenerative braking forces in (N) respectively, and $D_{B_{\text{Friction}}}$ and $D_{B_{\text{Regen}}}$ are the friction and regenerative brake commands. Regenerative braking is only effective at driven axles and is more efficient at the front axle due to the load transfer from rear to front during braking giving more grip and increasing the normal load at the front. In general, 65% of the braking energy goes to the front axle. In addition, regenerative braking at the rear axle is more limited by the legislation because the rear is more critical regarding wheel locking.²⁹ Furthermore, regenerative braking is found to be limited by several factors such as battery charging power limitation and SoC, vehicle speed and vehicle deceleration. A maximum regenerative braking power is set to protect the battery since the battery charging power is limited for battery protection. For the BMW i3, the regenerative braking power is limited to 55 kW at the wheels,³² which lead to a limit of about 53 kW at the electric motor considering the transmission efficiency of 97%.

The demanded motor braking power $P_{Br_demanded}$ is compared to the maximum regenerative motor braking power $P_{\text{Max_Regen}}$ to derive the limited motor braking torque $T_{Br_Limited}$ as follows:

- If $P_{Br_demanded} > P_{\text{Max_Regen}}$:

$$T_{Br_Limited} = \begin{cases} \frac{P_{\text{Max_Regen}}}{\omega_{\text{motor}(s)}}, & \text{if } \omega_{\text{motor}(s)} \neq 0 \\ 0, & \text{if } \omega_{\text{motor}(s)} = 0 \end{cases}$$

- If $P_{Br_demanded} \leq P_{\text{Max_Regen}}$:

$$T_{Br_Limited} = \begin{cases} \frac{P_{Br_demanded}}{\omega_{\text{motor}(s)}}, & \text{if } \omega_{\text{motor}(s)} \neq 0 \\ 0, & \text{if } \omega_{\text{motor}(s)} = 0 \end{cases}$$

where ω_{motor} is the motor speed in (rpm). Thereafter, the available electric motor brake command $EM_{\text{Available_BC}}$ is derived from the above limitation and the maximum available braking force as follows:

$$EM_{\text{Available_BC}} = \frac{T_{Br_Limited} \cdot G \cdot \eta_G}{r_d \cdot X_{B_{\text{MAX}}}}, \quad (10)$$

where G is the single-speed gear ratio, η_G is the transmission efficiency and r_d is the dynamic tyre radius in (m). At low speeds, regenerative braking is inefficient so, it is disabled for safety reasons as it may cause the vehicle to brake when the vehicle is started. Thus, regenerative braking is set to zero at low speeds and it is progressively increased for smooth operation.³⁸ Figure 6 shows the speed-dependent regeneration factor depending on

threshold speeds u_1 and u_2 that must be determined. The regeneration factor is set to 0 below u_1 and is increased linearly between u_1 and u_2 up to 1. Usually, u_1 and u_2 are set to 10 and 20 km/h respectively.³⁸

Above a certain level of deceleration, the electric motor is unable to brake the vehicle because the braking torque demand is too high, and the friction brakes must therefore be used. The deceleration limit is set at $0.7g$ where g is the acceleration due to gravity. Above this limit, regenerative braking is disabled as shown in Figure 6.

Regenerative braking also depends on the battery SoC. It is disabled for SoC above 95% to avoid recharging the battery when it is fully charged as shown in Figure 6.

The BMW i3 uses a series brake system because it is possible to brake most of the time by only releasing the accelerator pedal to recover as much kinetic energy as possible during the braking phases. The brake pedal is thus only necessary for a complete stop or emergency braking.^{39,40} A series brake system is thus considered based on the following algorithm:

- If $D_B < EM_{Available_BC}$: $\begin{cases} D_{B_{Regen}} = D_B \\ D_{B_{Friction}} = 0 \end{cases}$
- If $D_B \geq EM_{Available_BC}$: $\begin{cases} D_{B_{Regen}} = EM_{Available_BC} \\ D_{B_{Friction}} = D_B - EM_{Available_BC} \end{cases}$

where D_B is the driver's brake command, $D_{B_{Friction}}$ and $D_{B_{Regen}}$ are the friction and the regenerative brake commands respectively and $EM_{Available_BC}$ is the electric motor's available braking command. As a result, a regenerative braking strategy based on a series brake system is used in the proposed EV model by considering the limiting factors mentioned above.

2.2.3 | Power electronics and electric machine model

In this section, another sub-system of the proposed EV model is explained that is electric motor and power electronics. Since the goal of EV modelling is energy consumption estimation in this study, more focus here is on the efficiency of the electric motor and power electronics as it affects the overall energy consumption significantly. Energy losses due to the power electronics increase the energy that the battery has to provide to the electric motor and also reduce the energy effectively recovered from regenerative braking. The on-board charger is not considered in the model since the energy loss between the grid and the EV battery is neglected in this study. Thus, only the inverter and the converter are modelled here. The inverter efficiency is computed in Simulink using a 2D lookup table that is prepared according

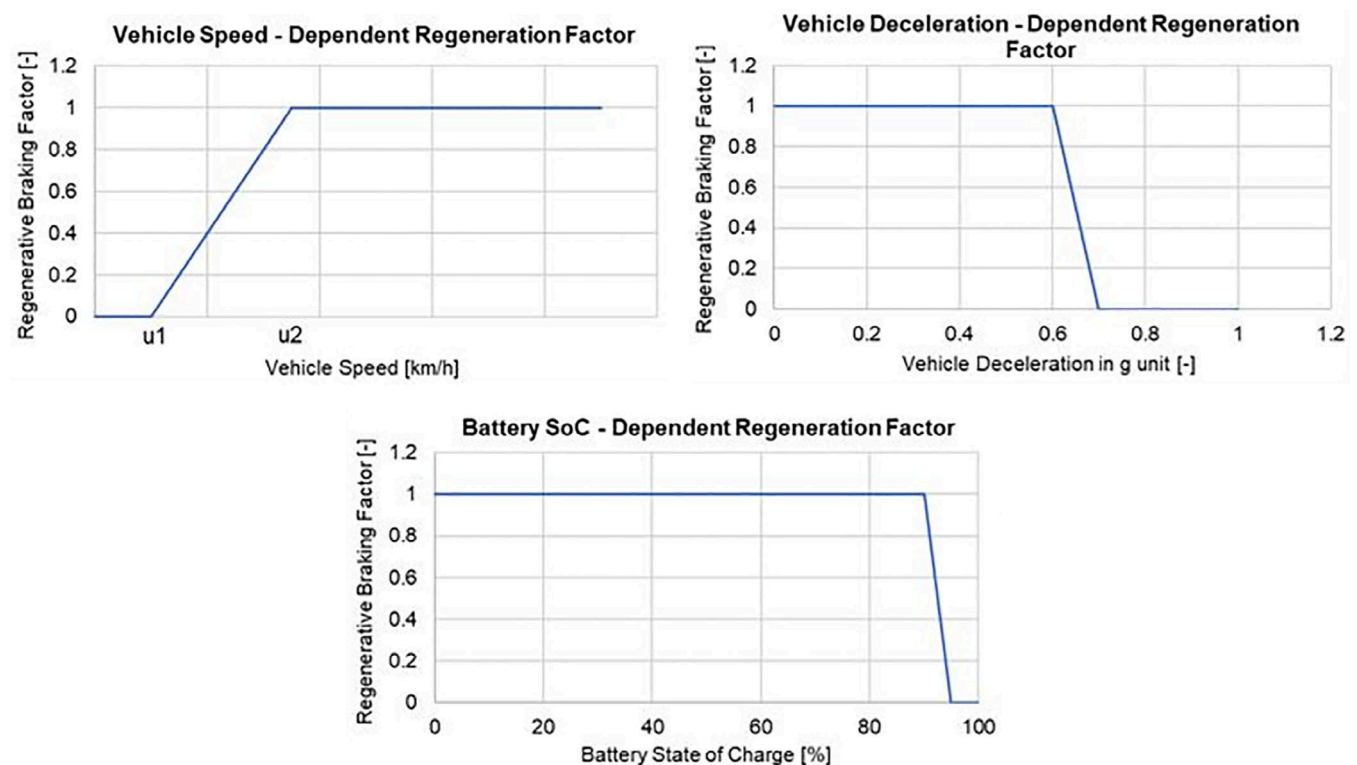

FIGURE 6 Regenerative braking factors as a function of vehicle speed, vehicle deceleration and battery State-of-Charge [Colour figure can be viewed at wileyonlinelibrary.com]

to the BMW i3 inverter efficiency map shown in Figure 2. Since no specific information was available about the converter technology used in the BMW i3 in the public domain, the converter efficiency is assumed to be 90% as the average DC/DC converter efficiency is around 90%.⁴¹

Motor torque in Nm, motor speed in rpm and motor efficiency must be taken into account in the vehicle model too as they affect the vehicle energy consumption. The torque demand is the input of the electric machine model whereas the output torque from the motor, by considering motor and inverter efficiencies, is the output. The torque demand T_{Dem} is derived from the driver model as follows:

$$T_{Dem} = T_{Max} \cdot D_A, \quad (11)$$

where T_{Max} is the maximum available torque in (N) and D_A is the driver acceleration command. T_{Max} is equal to the output torque from the motor divided by the efficiency of the motor and the inverter. The motor torque is computed in Simulink using a 1D lookup table that is prepared according to the electric motor torque curve shown in Figure 2. The motor efficiency is computed for a given motor speed and a given torque demand using a 2D lookup table that is prepared according to the available electric motor efficiency map. The electric machine model developed in MATLAB/Simulink is shown in Figure 7.

2.2.4 | Model of auxiliary devices

Nowadays, there are more and more auxiliary devices in vehicles for safety and comfort. They are powered

by a 12 V battery that is charged by the high voltage battery via a DC/DC converter. The power consumption of the auxiliary devices can significantly affect the overall EV's energy consumption. That is why, they must be included in the vehicle model for more accuracy. The power demand of auxiliary devices is calculated as follows:

$$P_{Dem} = \frac{P_{Ac}}{\eta_{DC/DC} \cdot \eta_{12V_bat}}, \quad (12)$$

where P_{Dem} is the power demand in (W), P_{Ac} is the power consumption of the auxiliary devices in (W) and $\eta_{DC/DC}$ and η_{12V_bat} are the DC/DC converter and the 12 V battery efficiencies respectively. The energy consumption of the auxiliary devices depends on several factors such as the ambient temperature. However, for the sake of simplicity, average values are extracted from the literature as stated in Table 3. The table includes the main auxiliary devices in an EV and their average power consumption.

Thereafter, the effective power consumption of the auxiliary devices are estimated based on the devices activated during the tests. For instance, during NEDC homologation tests, lights and auxiliary devices must be switched off, except those required for testing and day-time operation of the vehicle.³⁶ From the list of auxiliary devices shown in Table 3, it is assumed that only the driving control and energy management systems are activated during NEDC tests. Figure 8 shows the battery energy consumption with and without auxiliary load on the NEDC. The battery energy consumption increases by 9% with a load

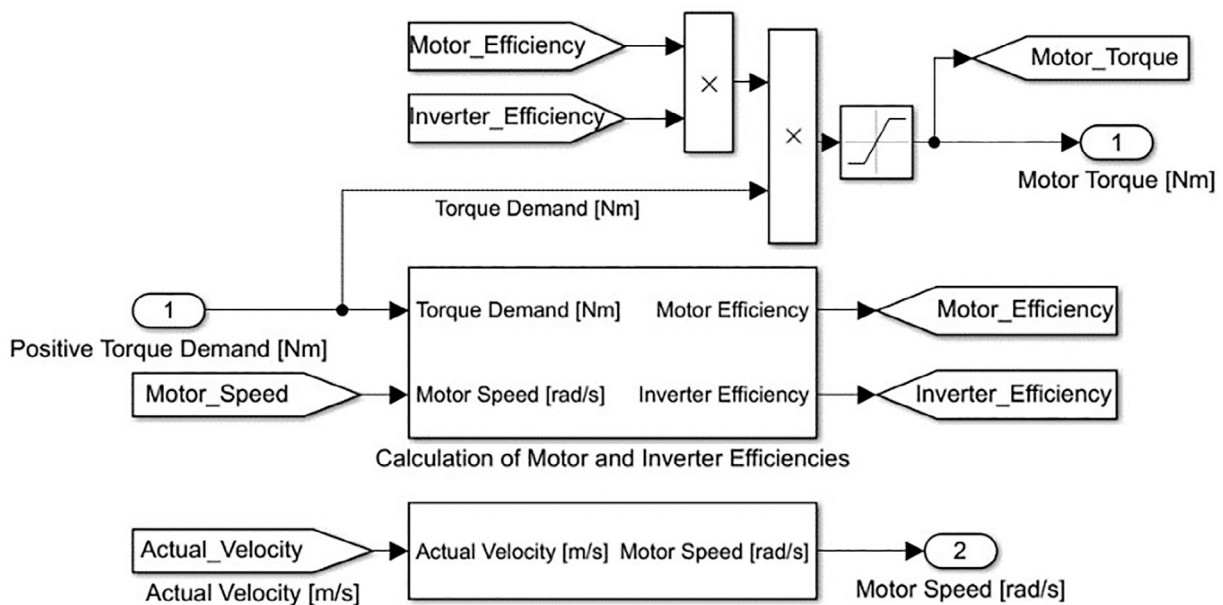
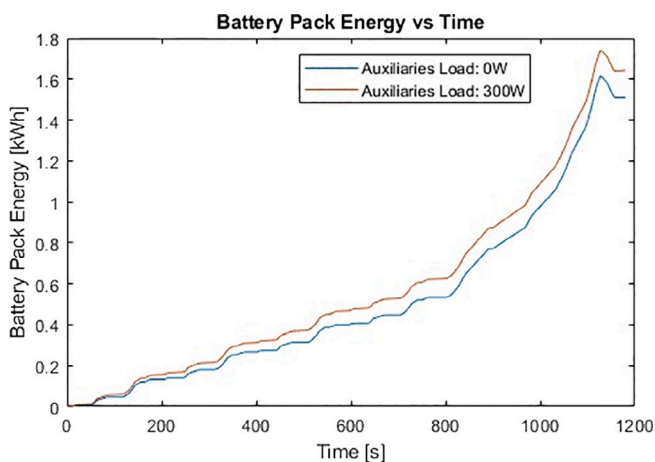

FIGURE 7 Electric machine model in Simulink

TABLE 3 List of the main electric vehicle auxiliaries^{42,43}

Subsystem	Operation mode	Power (W)
Air-conditioner	Continuous	500
Audio	Continuous	35
Driving control	Continuous	150
Energy management system	Continuous	150
Head and tail lamps	Continuous	120
Parking, turn and interior lamps	Intermittent	50
Horn	Intermittent	10
Power steering	Continuous	400
Power windows	Intermittent	80
Window defroster	Continuous	250
Wipers	Continuous	40

**FIGURE 8** Battery energy output on the New European Driving Cycle for different auxiliaries loads [Colour figure can be viewed at wileyonlinelibrary.com]

around 300 W. Therefore, auxiliary devices have a major impact on energy consumption and must be considered as accurately as possible.

2.2.5 | Battery model

There are two main energy storage systems in the BMW i3: the high voltage Lithium-ion battery pack used to propel the vehicle and the low voltage (12 V) Lead Acid battery that powers the auxiliary devices. In this Section, dynamic charging/discharging characteristics of the high voltage battery pack is modelled to determine its operating voltage and SoC with a satisfactory level of accuracy. The charging/discharging efficiency of both batteries is also considered as it affects the EV energy consumption.

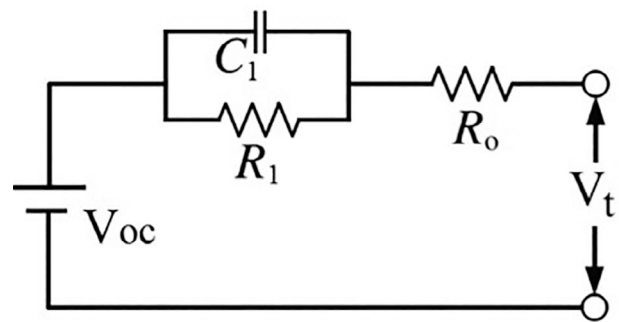
**FIGURE 9** Battery electrical circuit model (Thevenin model)

According to the literature, the charging/discharging efficiency of the Li-ion and the Lead Acid battery packs are assumed to be 95% and 80% respectively.²⁹

According to the literature, the two most widely used battery modelling techniques are the electrochemical and the equivalent circuit network (ECN) modelling techniques.⁴⁴ Electrochemical cell modelling approach is the most accurate approach however, it requires significant computational effort because of its complexity. On the other hand, ECN modelling approach is roughly accurate, and it can be used in real-time applications too. The high voltage battery is therefore modelled using Thevenin model that is the most famous ECN model shown in Figure 9. The model consists of an internal voltage source (V_{OC}), an ohmic resistance (R_O) and polarisation resistance (R_1) and capacitance (C_1).

From the above electrical circuit, the battery terminal voltage V_t is derived as a function of the current load I_L from Kirchhoff's Laws:

$$V_t = V_{OC} - R_O \cdot I_L - V_1, \quad (13)$$

$$\frac{dV_1}{dt} = -\frac{1}{R_1 \cdot C_1} V_1 + \frac{1}{C_1} I_L. \quad (14)$$

The model parameters V_{OC} , R_O , R_1 and C_1 are defined as a function of the battery SoC. The input of battery model is the total power demand for propulsion and auxiliary devices that takes into account the energy losses along the powertrain. On the other hand, the outputs of the model are battery terminal voltage and current obtained by the following equations:

$$V_{Bat_Pack} = V_{Cell} \cdot N_{Cells_series}, \quad (15)$$

$$I_{Bat_Pack} = I_{Cell} \cdot N_{Cells_parallel}, \quad (16)$$

where N_{Cells_series} and $N_{Cells_parallel}$ are the number of cells in series and in parallel respectively, V_{Cell} and

V_{Bat_Pack} are the single cell and the battery pack terminal voltage in (V) and I_{Cell} and I_{Bat_Pack} are the single cell and the battery pack's current (A). The battery model developed in MATLAB/Simulink is shown in Figure 10.

The single cell power demand $P_{Cell,dem}$ is derived by dividing the total power demand P_{dem} by the number of cells N_{Cells} . Thereafter, the single cell current demand $I_{Cell,dem}$ is derived from $P_{Cell,dem}$ as follows:

$$I_{Cell,dem} = \frac{\left(V_{OC} - \sqrt{V_{OC}^2 - 4 \cdot R_O \cdot P_{Cell,dem}} \right)}{2 \cdot R_O} \quad (17)$$

The single cell current demand is calculated considering a power limitation to protect the battery considering the cut-off voltage of the battery cell. The current demand is positive in traction mode while it is negative in regenerative mode. After being derived from the power demand, as explained above, the

current demand is adjusted according to the charging/discharging battery efficiency. Subsequently, the Thevenin model has been modelled in MATLAB/Simulink based on Equations (11) and (12) as shown in Figure 10.

The battery SoC is updated at each time step using the current integration method, also known as ‘‘Coulomb counting,’’ presented in Equation (16). Although this method is not useable in a real application (because of measurement noise, etc.), it is quite useful and accurate in simulation environment.

$$SoC = SoC_0 - \left(\int_{t_0}^t \frac{I_{Cell,dem}(\tau)}{C_{cell}} d\tau \right), \quad (18)$$

where SoC is the battery state-of-charge in (%), SoC_0 is the initial battery state-of-charge in (%), C_{cell} is the single cell capacity in (Ah) and $I_{Cell,dem}$ is the single cell current demand in (A).

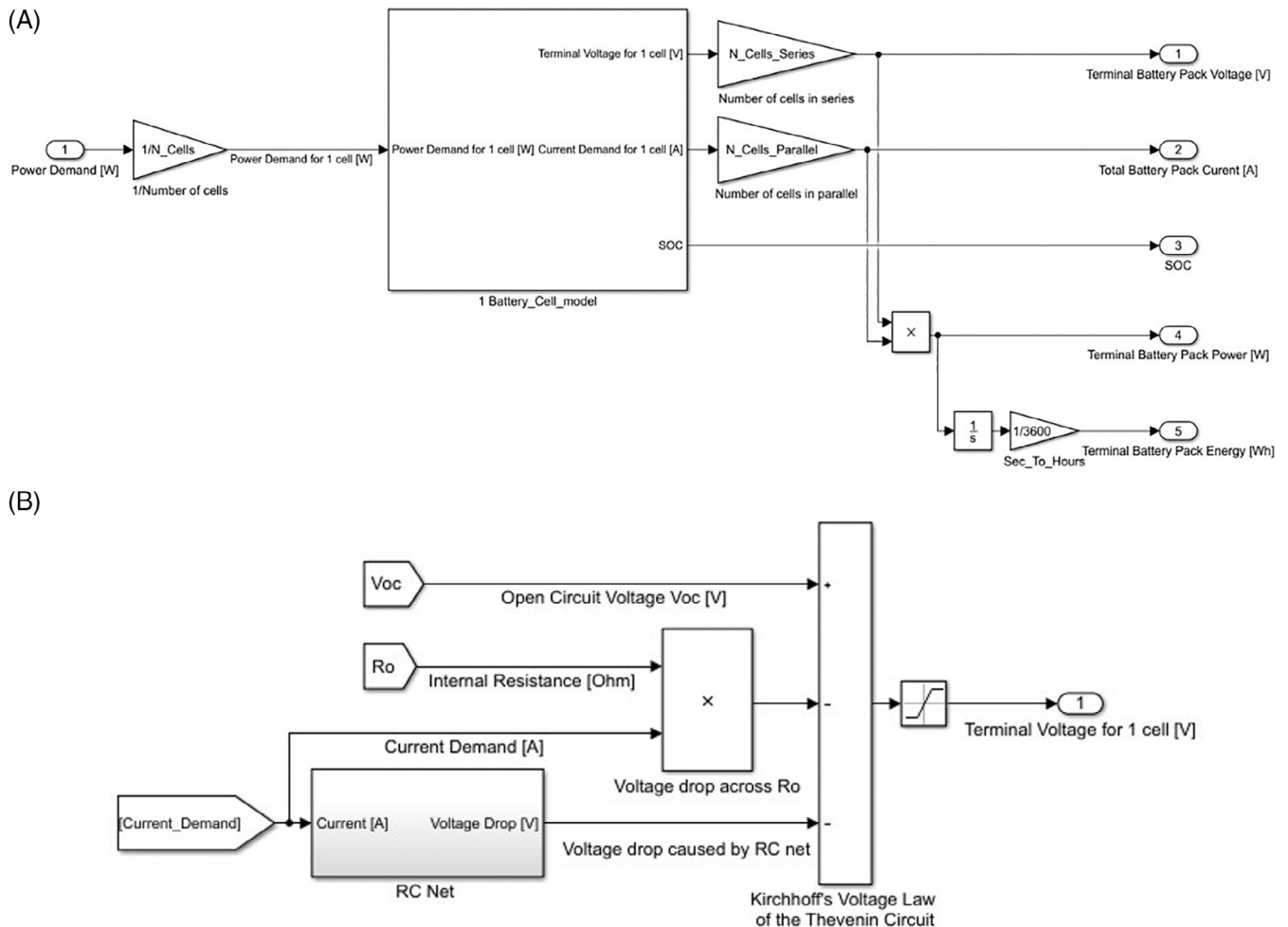

FIGURE 10 A, Battery model and B, single cell model (Thevenin model) built in MATLAB/Simulink

2.2.6 | Transmission model

Transmission system aims to transfer the torque between the motor and the driving wheels. Efficiency of the transmission system affects the EV energy consumption and is defined in both traction and regenerative modes, as follows:

$$\eta_{g_traction_mode} = \frac{T_{wheels} \cdot \omega_{wheels}}{T_{motor(s)} \cdot \omega_{motor(s)}}, \quad (19)$$

$$\eta_{g_regenerative_mode} = \frac{T_{motor(s)} \cdot \omega_{motor(s)}}{T_{wheels} \cdot \omega_{wheels}}, \quad (20)$$

where ω_{wheels} and $\omega_{motor(s)}$ are the wheels and the motor speed respectively in (rad/s), T_{wheels} is the torque at the driving wheels in (Nm) and $T_{motor(s)}$ is the motor torque in (Nm).

The transmission model is derived based on the following equation:

$$F_T = \frac{T_{motor(s)} \cdot G \cdot \eta_G}{r_d}, \quad (21)$$

where F_T is the tractive force in (N), G is the single speed gear ratio, r_d is the dynamic tyre radius in (m) and η_G is the transmission efficiency that is assumed to be 97%.^{38,45}

2.2.7 | Longitudinal vehicle dynamics

The following opposing forces are considered in the proposed model as a common technique in the literature³⁷ as shown in Figure 11:

- Gradient Resistance Force R_θ due to the road inclination with regard to the horizontal plane.
- Rolling Resistance Force R_R mainly due to the friction between the tyres and the road.
- Aerodynamic Drag Force R_A due to the friction between the vehicle body and the air.
- Inertia Resistance Force R_I related to the forces required for the linear acceleration of the vehicle R_{Ia} and the increase of the rotational speed of the rotating components R_{Ie} .
- Transmission Resistance Force R_T related to the losses between the motor and the wheels due to the transmission efficiency η_G .

Thereafter, the power required at the wheels P_{Wheels} to overcome the opposing forces is derived as follows:

$$P_{Wheels} = (R_\theta + R_R + R_A + R_I + R_T) \cdot V_{Vehicle}, \quad (22)$$

where:

$$R_\theta = M_{Vehicle} \cdot g \cdot \sin\alpha, \quad (23)$$

$$R_R = C_{RR} \cdot M_{Vehicle} \cdot g \cdot \cos\alpha, \quad (24)$$

$$R_A = \frac{1}{2} \cdot \rho \cdot A_F \cdot C_d \cdot (V_{Vehicle} - V_{wind})^2, \quad (25)$$

$$R_I = R_{Ia} + R_{Ie} = \delta \cdot M_{Vehicle} \cdot a, \quad (26)$$

$$R_T = (R_R + R_A + R_\theta + R_I) \cdot \frac{(1 - \eta_G)}{\eta_G}. \quad (27)$$

In the above equations, $V_{Vehicle}$ is the vehicle speed in (m/s), and V_{wind} is the wind speed that has a positive sign when it is tailwind and a negative sign when it is headwind. C_{RR} is the coefficient of rolling resistance, $M_{Vehicle}$ is the vehicle mass in (kg), g is the acceleration due to gravity (m/s^2), α is the angle of inclination of the road in ($^\circ$), ρ is the air density in (kg/m^3), A_F is the vehicle frontal area in (m^2), C_d is the drag coefficient, a is the vehicle acceleration in (m/s^2) and δ is the coefficient of rotary inertia that is assumed to be around 1.15 (typical value). C_{RR} can be approximated as a linear function of vehicle speed for a passenger car on concrete roads for most of the tyre inflation pressure. This approximation provides a satisfactory estimation for speeds up to 128 km/h.²⁹

$$C_{RR} = 0.01 \cdot \left(1 + \frac{V_{Vehicle}}{100}\right). \quad (28)$$

3 | VEHICLE MODEL VALIDATION

In this section, the proposed model is validated against published values in the literature. For this purpose, energy consumption values on NEDC and Environmental Protection Agency (EPA) cycles are used as explained in the following.

3.1 | Tests characteristics

NEDC and EPA test procedures consider a combination of urban and extra-urban driving patterns to take into account the vehicle behaviour under different driving conditions. Both tests are performed indoors on a chassis

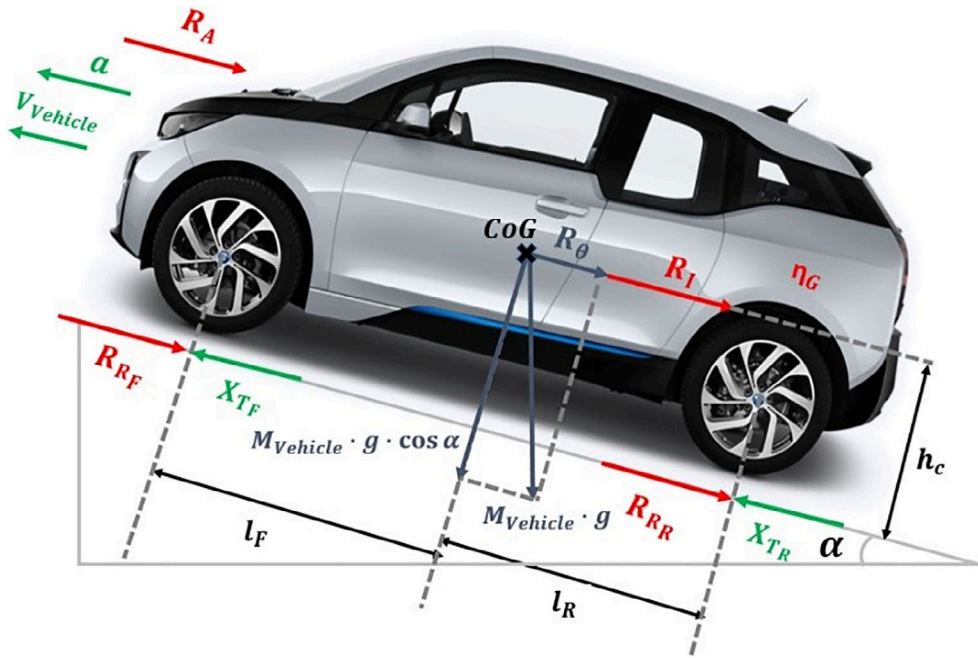

FIGURE 11 Forces acting on the moving vehicle [Colour figure can be viewed at wileyonlinelibrary.com]

dynamometer, so there is no wind or variation in the slope of the road.^{36,46}

3.1.1 | NEDC procedure

The NEDC is the former cycle used for EU homologation tests. It was replaced by Worldwide Harmonised Light Vehicle Test Procedure drive cycle that is more representative of real driving conditions. However, the homologation of the 2014 BMW i3 60Ah REx was carried out on the NEDC as it was still applicable before 2014. NEDC is a combined five-cycle test with four elementary urban cycles and an extra-urban cycle as shown in Figure 12. Before testing, the vehicle is fully charged and is then run twice over the cycle. Among the auxiliary devices listed in Table 3, only the driving control device and the energy management system are assumed to be activated during the NEDC test because only the auxiliary devices necessary for normal day-time operation of the vehicle shall be activated.³⁶

3.1.2 | EPA procedure

The US homologation is based on the EPA test procedure. For this purpose, the vehicle is fully charged the day before and then it is driven over the cycle during the test until battery is fully discharged.⁴⁶ The test consists of a combination of 4 cycles shown in Figure 12: Federal Test Procedure-75 (FTP-75) (city cycle), Highway

Fuel Economy Test (HWFET) (highway cycle), SC03 Supplemental FTP (use of air-conditioning) and US06 Supplemental FTP (high speeds and accelerations).

Tests on FTP-75, HWFET and US06 cycles are run without activated auxiliary devices, except those required in the US for usual day-time operation: head and tail lamps, driving control device and energy management system. For the SC03 test, air conditioning is activated in addition to the other devices to measure the impact of air conditioning on the vehicle energy consumption.⁴⁶

3.2 | Energy consumption calculation

In the NEDC test procedure, energy consumption E_{cons} is calculated using Equation (27).³⁶

$$E_{cons} = \frac{E}{D_{test}}, \tag{29}$$

where E is the energy consumed in (Wh) and D_{test} is the distance covered in (km) during the test.

In the EPA test procedure, combined energy consumption, $Combined_{FC}$, is calculated as a combination of the city and the highway energy consumption, $City_{FC}$ and $Highway_{FC}$, respectively⁴⁶:

$$City_{Running_{FE}} = 0.82 \cdot \left(\frac{0.89}{FTP} + \frac{0.11}{US06} \right) + \frac{0.18}{FTP} + 0.133 \cdot 1.083 \cdot \left(\frac{1}{SC03} - \frac{1}{FTP} \right), \tag{30}$$

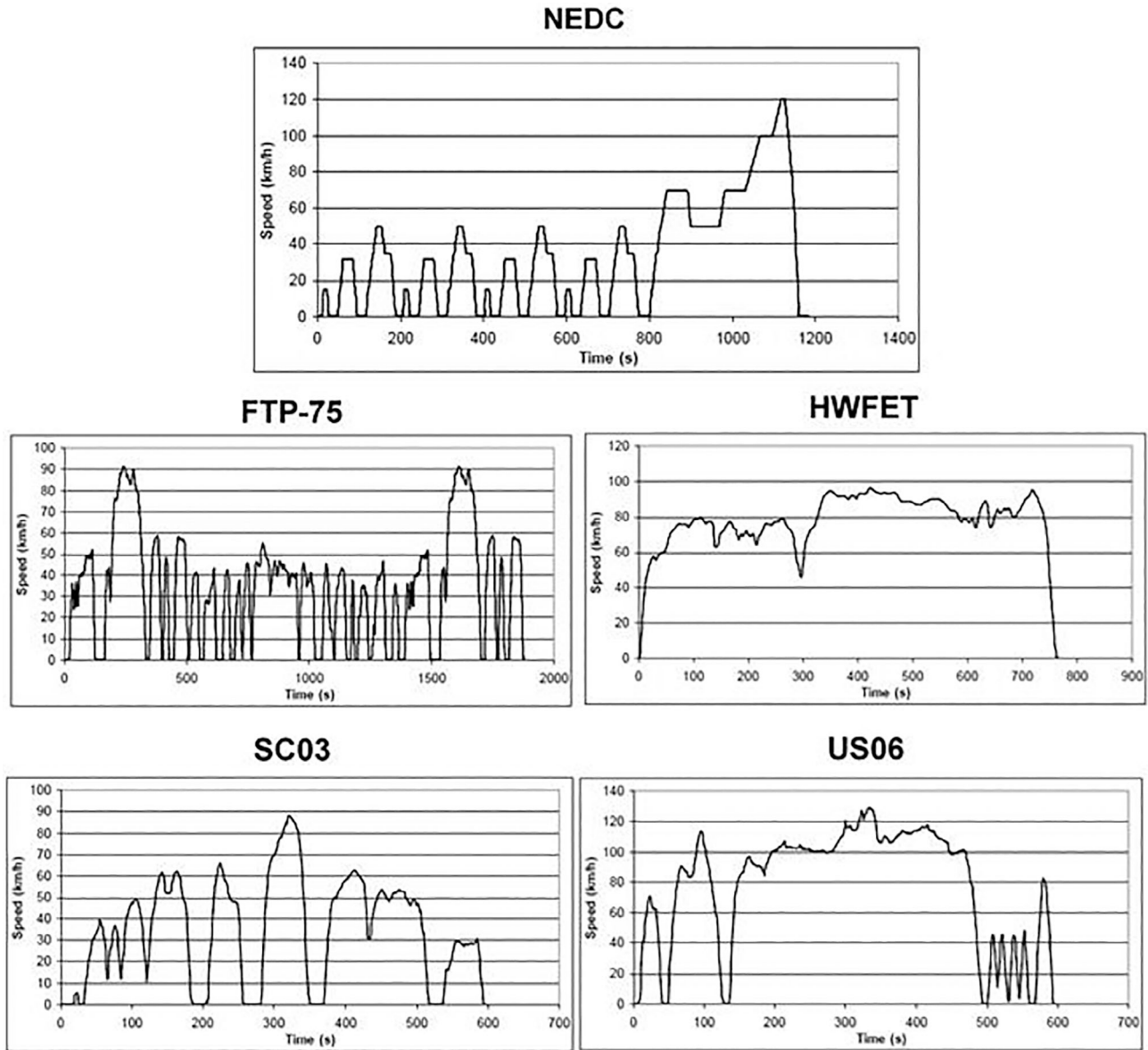

FIGURE 12 Speed profiles used in the simulations⁴⁷

$$\text{City}_{\text{FC}} = \frac{1}{0.905} \cdot \frac{1}{\text{City}_{\text{Running}_{\text{FE}}}}, \quad (31)$$

$$\begin{aligned} \text{Highway}_{\text{Running}_{\text{FE}}} &= 1.007 \left(\frac{0.79}{\text{US06}} + \frac{0.21}{\text{HWFET}} \right) \\ &+ 0.133 \cdot 0.377 \left(\frac{1}{\text{SC03}} - \frac{1}{\text{FTP}} \right), \quad (32) \end{aligned}$$

$$\text{Highway}_{\text{FC}} = \frac{1}{0.905} \cdot \frac{1}{\text{Highway}_{\text{Running}_{\text{FE}}}}, \quad (33)$$

$$\text{Combined}_{\text{FC}} = 0.55 \cdot \text{City}_{\text{FC}} + 0.45 \cdot \text{Highway}_{\text{FC}}, \quad (34)$$

where FTP, US06, SC03 and HWFET are the energy consumption values for the corresponding cycles in

(Wh/km), and $\text{City}_{\text{Running}_{\text{FE}}}$ and $\text{Highway}_{\text{Running}_{\text{FE}}}$ are the city and the highway fuel economy values in (km/Wh).

3.3 | Simulation results and model validation

According to the literature, the combined energy consumption of 2014 BMW i3 60 Ah REx is 135 Wh/km on the NEDC³¹ while it is 117 mpg (179 Wh/km) on EPA cycles.³² In this study, simulation case-studies are performed considering five different drive cycles: NEDC, FTP-75, HWFET, SC03 and US06. For each cycle, two cases are simulated:

- Case 1 No auxiliary device is activated.
- Case 2 Some auxiliary devices are activated as described in Section 3.1, based on the devices activated during each driving test which is described by the homologation procedure.^{36,46}

The energy consumption values obtained from the simulations are compared to the above values found in the literature as presented in Tables 4 and 5. For NEDC cycle, the error between simulation and experimental results is about 3% when auxiliary devices are not included in the model whereas the error increases up to 5.9% when the power consumption of the auxiliary devices is assumed to be 300 W. When the auxiliary devices are included in the model, the vehicle energy consumption from the simulation model becomes higher than the actual value from

the test. The increase of the error may be due to the fact that the auxiliary load is overestimated in this study and was less than 300 W during the NEDC test. Besides, the approximation is not precise as it is based on the power consumption of usual auxiliary devices which might be different for the BMW i3. For EPA cycles, the error between the simulation and experimental results decreases significantly from 10.6% to 1.1% when auxiliary devices are included in the model, which leads to a higher accuracy of the model. As aforementioned, EPA cycles are run with some auxiliary devices turned on such as air-conditioning and lamps, which explains the significant error between simulation and experimental results when those devices are assumed to be turned off.⁴⁶ Overall, the model demonstrates a satisfactory level of accuracy in view of NEDC and EPA simulation results.

TABLE 4 Simulation results on NEDC and EPA cycles

Energy consumption	Case 1	Case 2	
NEDC Cycle			
NEDC	130.67	142.66	Wh/km
EPA Cycles			
FTP-75	114.58	130.95	Wh/km
SC03	111.69	147.42	Wh/km
US06	191.69	201.93	Wh/km
HWFET	139.99	146.28	Wh/km
EPA city			
1/City running FE (fuel economy)	118.44	137.52	Wh/km
City FC (fuel consumption)	130.87	151.96	Wh/km
EPA highway			
1/Highway running FE	176.30	187.18	Wh/km
Highway FC	194.81	206.83	Wh/km
EPA combined			
Combined FC	159.6	176.6	Wh/km

Abbreviations: EPA, Environmental Protection Agency; FTP-75, Federal Test Procedure-75; HWFET; Highway Fuel Economy Test; NEDC, New European Driving Cycle.

4 | CONCLUSIONS

The main purpose of this study was to develop an accurate computer-based model to estimate EV energy consumption along with a given driving cycle. The BMW i3 was selected to be modelled as a case-study to prove the concept. A forward vehicle simulation model was developed in MATLAB/Simulink, including the powertrain system and the longitudinal vehicle dynamics. The powertrain model was implemented using accurate efficiency maps of both the electric motor and the inverter. The powertrain system also includes transmission and battery where the Thevenin equivalent circuit battery model was used. Moreover, the resistance forces opposed to the vehicle motion were modelled in the longitudinal vehicle dynamics. A driver model was developed using a PI controller to control the vehicle's speed. In addition, a regenerative braking strategy that models the behaviour of a real braking controller was developed to distribute the braking torque demand between the friction and regenerative brakes. Finally, the model was validated using the publicly available data from BMW and other reliable sources in the literature. As a novelty of this work, power

TABLE 5 Comparison between experimental and simulation results on EPA and NEDC cycles

Tests			Simulation		
			Case 1	Case 2	
NEDC	Energy consumption (Wh/km)	135	Energy consumption (Wh/km)	131	143
	Error (%)			-3.0	+5.9
EPA	Energy consumption (Wh/km)	179	Energy consumption (Wh/km)	158	176
	Error (%)			-15.6	-2.2

Abbreviations: EPA, Environmental Protection Agency; NEDC, New European Driving Cycle.

consumption of the auxiliary devices was also estimated from average values found in the literature to be included in the proposed model as they can have a significant impact on energy consumption. In addition, the powertrain efficiency is estimated with better accuracy compared to other studies, which only consider the electric motor efficiency. In this study, the inverter efficiency is calculated from an available efficiency map of the BMW i3 inverter. This more accurate estimation of the powertrain efficiency leads to an improved estimation of the EV energy consumption. The model has demonstrated a satisfactory level of accuracy with less than 6% error between the simulation results and test data for both EPA and NEDC tests.

As a perspective to future research of this study, the proposed model can potentially be used as a base for EV range estimation. For this purpose, additional information about the road such as traffic and weather conditions and also driver's characteristics should be added. In addition, the battery model can be improved by considering the effects of battery SoC and state-of-health (SoH) which have a major impact on battery efficiency and energy consumption. In addition, the inertia of the vehicle's rotating components such as the wheels, brakes and rotor can be also calculated and included in the model to improve its accuracy.

ORCID

Abbas Fotouhi  <https://orcid.org/0000-0002-5402-8629>

REFERENCES

- Nilsson, M. (2011), Electric Vehicles The Phenomenon of Range Anxiety. <https://cordis.europa.eu/docs/projects/cnect/5/249105/080/deliverables/001-ThephenomenonofrangeanxietyELVIRE.pdf>
- Hong, J., Park, S. and Chang, N. (2016). Accurate remaining range estimation for Electric vehicles. Paper presented at: Proceedings of the Asia and South Pacific Design Automation Conference, ASP-DAC. IEEE, January 25-28, pp. 781-786. <https://doi.org/10.1109/ASPDAC.2016.7428106>
- Luigi Mapelli F, Tarsitano D. Modeling of full electric and hybrid electric vehicles. *New Generation of Electric Vehicles*. London, UK: IntechOpen; 2012:207-236. <https://doi.org/10.5772/53570>.
- van Mierlo, J., Maggetto, G. and van den Bossche, P. (2004). Simulation methodologies for innovative vehicle drive systems. <http://etec.vub.ac.be/publications/A71712.pdf>
- Horrein L, Bouscayrol A, Delarue P, Verhille JN, Mayet C. Forward and backward simulations of a power propulsion system. *IFAC Proc Vol.* 2012;45:441-446. <https://doi.org/10.3182/20120902-4-FR-2032.00078>.
- Hauer KH, Moore RM. Fuel cell vehicle simulation– part 1: benchmarking available fuel cell vehicle simulation tools. *Fuel Cells*. 2003;3(3):84-94. <https://doi.org/10.1002/fuce.200332102>.
- Qi X, Wu G, Boriboonsomsin K, Barth MJ. Data-driven decomposition analysis and estimation of link-level electric vehicle energy consumption under real-world traffic conditions. *Transp Res Part D: Transp Environ.* 2018;64:36-52. <https://doi.org/10.1016/j.trd.2017.08.008>.
- Pan C, Dai W, Chen L, Chen L, Wang L. Driving range estimation for electric vehicles based on driving condition identification and forecast. *AIP Adv.* 2017;7(10):105206. <https://doi.org/10.1063/1.4993945>.
- Moure, C., Roche, M. and Mammetti, M. (2014). Range estimator for electric vehicles. Paper presented at: 2013 World Electric Vehicle Symposium and Exhibition, EVS 2014, pp. 1–15. <https://doi.org/10.1109/EVS.2013.6914917>
- Jiquan Wang (2016) Battery electric vehicle energy consumption modelling, testing and prediction: a practical case study. Eindhoven: Technische Universiteit Eindhoven. <https://doi.org/10.1111/nhs.12017>
- Kim, E., Lee, J. and Shin, K. G. (2013). Real-time prediction of battery power requirements for electric vehicles. Paper presented at: 2013 ACM/IEEE International Conference on Cyber-Physical Systems, ICCPS 2013, pp. 11–20. <https://doi.org/10.1109/ICCPS.2013.6603995>
- Fiori C, Ahn K, Rakha HA. Power-based electric vehicle energy consumption model: model development and validation. *Appl Energy.* 2016;168:257-268. <https://doi.org/10.1016/j.apenergy.2016.01.097>.
- Wu X, Freese D, Cabrera A, Kitch WA. 'Electric vehicles' energy consumption measurement and estimation. *Transp Res Part D: Transp Environ.* 2015;34:52-67. <https://doi.org/10.1016/j.trd.2014.10.007>.
- Zhang R, Yao E. 'Electric vehicles' energy consumption estimation with real driving condition data. *Transp Res Part D: Transp Environ.* 2015;41:177-187. <https://doi.org/10.1016/j.trd.2015.10.010>.
- De Cauwer C, Van Mierlo J, Coosemans T. Energy consumption prediction for electric vehicles based on real-world data. *Energies.* 2015;8(8):8573-8593. <https://doi.org/10.3390/en8088573>.
- De Cauwer C, Verbeke W, Coosemans T, Faïd S, Van Mierlo J. A data-driven method for energy consumption prediction and energy-efficient routing of electric vehicles in real-world conditions. *Energies.* 2017;10(5):10. <https://doi.org/10.3390/en10050608>.
- Kriesel D. A brief introduction on neural networks. *Lancet.* 2007;346:1712. [https://doi.org/10.1016/S0140-6736\(95\)92880-4](https://doi.org/10.1016/S0140-6736(95)92880-4).
- Diaz Alvarez A, Serradilla Garcia F, Naranjo JE, Anaya JJ, Jimenez F. Modeling the driving behavior of electric vehicles using smartphones and neural networks. *IEEE Intell Transp Syst Mag.* 2014;6(3):44-53. <https://doi.org/10.1109/MITS.2014.2322651>.
- Saurav, K. (2016). An Introduction to Clustering and different methods of clustering, Analytics Vidhya. <https://www.analyticsvidhya.com/blog/2016/11/an-introduction-to-clustering-and-different-methods-of-clustering/>. Accessed: April 26, 2019.
- Fotouhi A, Yusof R, Rahmani R, Mekhilef S, Shateri N. A review on the applications of driving data and traffic information for vehicles' energy conservation. *Renew Sust Energ Rev.* 2014;37:822-833.
- Montazeri M, Fotouhi A, Naderpour A. Driving segment simulation for determination of the most effective driving features for HEV intelligent control. *Veh Syst Dyn.* 2012;50(2):229-246.
- Montazeri-Gh M, Fotouhi A, Naderpour A. Driving patterns clustering based on driving feature analysis. *Proc Inst Mech Eng C J Mech Eng Sci.* 2011;225(6):1301-1317.

23. Montazeri-Gh M, Fotouhi A. Traffic condition recognition using the k-means clustering method. *Sci Iran*. 2011;18(4): 930-937.
24. Lee CH, Wu CH. A novel big data modeling method for improving driving range estimation of EVs. *IEEE Access*. 2015; 3:1980-1993. <https://doi.org/10.1109/ACCESS.2015.2492923>.
25. Ye, F., Wu, G., Boriboonsomsin, K., Barth, M. J. (2016). A hybrid approach to estimating electric vehicle energy consumption for ecodriving applications. *IEEE*. <https://ieeexplore.ieee.org/document/7795633>
26. Islam, E., Moawad, A., Kim, N., Rousseau, A. (2018) An Extensive Study on Sizing, Energy Consumption, and Cost of Advanced Vehicle Technologies. https://www.autonomie.net/pdfs/ANL_BaScE_FY17_Report_10042018.pdf
27. Armstrong, C. (2015) Eco-Approach and Departure at Signalized Intersections. https://rosap.ntl.bts.gov/view/dot/34781/dot_34781_DS1.pdf
28. Fotouhi, A., Auger, D. J., Propp, K., Longo, S. (2015). Simulation for prediction of vehicle efficiency, performance, range and lifetime: A review of current techniques and their applicability to current and future testing standards. (November 2014), p. 9.1–9.1. <https://doi.org/10.1049/cp.2014.0959>
29. Ehsani M, Gao Y, Gay S, Emadi A. *Modern Electric, Hybrid Electric, and Fuel Cell Vehicles. Fundamentals, Theory, and Design*. Florida: CRC Press LLC; 2005.
30. i3 Guide (2014). I3's Range. <http://www.i3guide.com/range.html>. Accessed May 31, 2019.
31. BMW Group (2013). The BMW i3 Experience. https://www.bmw.no/content/dam/bmw/marketNO/bmw_no/brosjyre/i3PSLEAL_web.pdf
32. BMW Group (2014). BMW U.S. Media Information Technical Data 2014 BMW i3. https://www.press.bmwgroup.com/usa/article/detail/T0149790EN_US/the-all-new-bmw-i3?language=en_US
33. Idaho National Laboratory (2016). 2014 BMW i3 with Range Extender (REx) Advanced Vehicle Testing – Baseline Vehicle Testing Results. pp. 3–7. <https://avt.inl.gov/sites/default/files/pdf/phev/fact2014bmwi3rex.pdf>
34. Oak Ridge National Laboratory (2016) Oak Ridge National Laboratory Annual Progress Report for the Electric Drive Technologies Program. <https://info.ornl.gov/sites/publications/Files/Pub71072.pdf>
35. BMW Group (2014) The Hybrid-Synchronous Machine of the New BMW i3 & i8, pp. 1–9. http://hybridfordonscentrum.se/wp-content/uploads/2014/05/20140404_BMW.pdf
36. United Nations Economic Commission for Europe (2013) Agreement Concerning the Adoption of Uniform Technical Prescriptions for Wheeled Vehicles, Equipment and Parts which can be fitted and/or be used on Wheeled Vehicles and the Conditions for Reciprocal Recognition of Approvals Granted on the Basis of these. <https://www.unece.org/fileadmin/DAM/trans/main/wp29/wp29regs/2015/R101r3e.pdf>
37. Larminie, J. and Lowry, J. (2012) Electric Vehicle Technology Explained, Electric Vehicle Technology Explained. <https://doi.org/10.1002/9781118361146>
38. Genikomsakis KN, Mitrentsis G. A computationally efficient simulation model for estimating energy consumption of electric vehicles in the context of route planning applications. *Transp Res Part D: Transp Environ*. 2017;50:98-118. <https://doi.org/10.1016/j.trd.2016.10.014>.
39. Green Car Congress (2013) More details on BMW's i3; electric and connected. <https://www.greencarcongress.com/2013/07/bmwi3-20130710.html>. Accessed June 17, 2019.
40. Goodwin, A. (2015) 2014 BMW i3 with range extender review: BMW's lightweight EV looks strange, drives strangely, CNET. <https://www.cnet.com/roadshow/reviews/2014-bmw-i3-review/>. Accessed June 17, 2019.
41. Abatte, N. (2008). DC-DC converter for Hybrid Electric Vehicle and EV. *Arrow Times*, p. 7. <https://pdfs.semanticscholar.org/697d/cf2b439aa90638413daa8e3c4aec591fd51f.pdf>
42. Schaltz E. Electrical vehicle design and modeling. *Electric Vehicles - Modelling and Simulations*. London, UK: IntechOpen; 2012. <https://doi.org/10.5772/20271>.
43. Chan CC, Chau KT. *Modern Electric Vehicle Technology*. Oxford, UK: Oxford University Press; 2001.
44. Fotouhi A, Auger DJ, Propp K, Longo S, Wild M. A review on electric vehicle battery modelling: from Lithium-ion toward lithium-Sulphur. *Renew Sust Energy Rev*. 2016;56:1008-1021. <https://doi.org/10.1016/j.rser.2015.12.009>.
45. Hayes, J. G., De Oliveira, R. P. R., Vaughan, S. and Egan, M. G. (2011). Simplified electric vehicle power train models and range estimation. Paper presented at: 2011 IEEE Vehicle Power and Propulsion Conference, VPPC 2011 IEEE, pp. 1–5. doi: <https://doi.org/10.1109/VPPC.2011.6043163>
46. Environmental Protection Agency (2006) Fuel Economy Labeling of Motor Vehicles: Revisions To Improve Calculation of Fuel Economy Estimates. <https://www.govinfo.gov/content/pkg/FR-2006-12-27/pdf/06-9749.pdf>
47. T. J. Barlow I. S. McCrae, and P. G. Boulter, S. L. (2009). A reference book of driving cycles for use in the measurement of road vehicle emissions. https://www.gov.uk/government/uploads/system/uploads/attachment_data/file/4247/ppr-354.pdf

How to cite this article: Miri I, Fotouhi A, Ewin N. Electric vehicle energy consumption modelling and estimation—A case study. *Int J Energy Res*. 2021;45:501–520. <https://doi.org/10.1002/er.5700>

2020-07-12

Electric vehicle energy consumption modelling and estimation A case study

Miri, Ilyès

Wiley

Miri I, Fotouhi A, Ewin N. (2021) Electric vehicle energy consumption modelling and estimation
a case study. *International Journal of Energy Research*, Volume 45, Iss
pp. 501-520

<https://doi.org/10.1002/er.5700>

Downloaded from Cranfield Library Services E-Repository