

Energy Management in Plug-in Hybrid Electric Vehicles: Recent Progress and a Connected Vehicles Perspective

Clara Marina Martínez, Xiaosong Hu*, Dongpu Cao*, Efstathios Velenis, Bo Gao and Matthias Wellers

Abstract—Plug-in hybrid electric vehicles (PHEVs) offer an immediate solution for emissions reduction and fuel displacement within the current infrastructure. Targeting PHEV powertrains optimization, a plethora of energy management strategies (EMSs) have been proposed. Albeit these algorithms present various levels of complexity and accuracy, they find a limitation in terms of availability of future trip information, which generally prevents from exploiting the full PHEV potential in real-life cycles. This paper presents a comprehensive analysis of EMSs evolution towards blended mode and optimal control, providing a thorough survey of the latest progress in optimization-based algorithms. This is performed in the context of connected vehicles, and highlights certain contributions that intelligent transportation systems (ITS), traffic information, and cloud computing can provide to enhance PHEV energy management. The study is culminated with an analysis of future trends in terms of: optimization algorithm development, optimization criteria, PHEV integration in the smart grid, and vehicles as part of the fleet.

Index Terms—Energy Management Strategy (EMS), Plug-in Hybrid Electric Vehicle (PHEV), Optimal Control, Intelligent Transportation Systems (ITS), Connected Vehicles.

I. INTRODUCTION

Air quality has become a serious concern in cities and urban areas in the recent years. This has promoted new legislation, affecting the European automotive sector through Euro I-VI, which limits emissions of: CO, HC, NO_x, and particulate matter [1]. As Euro VI became into force, the spotlight is nowadays on CO₂ emissions. The European commission has established 130 g CO₂/km target for 2015, which will be reduced to 95g CO₂/km in 2021 [2]. Similar policies have been imposed in other automotive markets, such as USA, China, and Japan. This legislation has encouraged the introduction of hybrid electric vehicles (HEVs), which have been considered as the most liable and immediate choice by car manufacturers. HEVs refer to vehicles powered by at least two power sources, usually concerning an internal combustion engine (ICE) and an electric motor (EM) [3]. Battery capacity, EM power limits, and grid

charge capabilities define different levels of electrification. The ultimate case is the technology of plug-in hybrid electric vehicles (PHEVs), which can be recharged directly from the grid. The network support allows the integration of a high capacity battery and powerful EM, which becomes co-leader in the PHEV propulsion along with the engine. Consequently, PHEVs have larger margin of efficiency improvement than HEVs, which results in further fuel displacement [4].

As a result of multiple power sources, (P)HEVs have more degrees of freedom to supply the power demand, compared to conventional vehicles. Therefore, their energy management is framed as power/torque split selection, namely, determining the amount of power/torque that each of the sources provides to satisfy the driver demand. Energy management usually targets to maximize the overall powertrain efficiency and minimize fuel consumption [3], while the associated algorithm implemented for this purpose is referred to as energy management strategy (EMS).

Raghavan *et al.* [5] measured PHEV impacts with an energy-based analysis, obtaining valuable insights into fuel consumption reduction through the electrification potential factor (EPF). This factor is leveraged to rate the electrification level and payback time with respect to the vehicle additional price and lower running cost. However, the actual amount of fuel displaced is tightly coupled with the EMS capacity to maximize electricity use and optimize the overall system efficiency. In practice, the fulfilment of optimal control of PHEVs hinges on key information about drive cycle, which is necessary to schedule conveniently the battery depletion. Such desirable strategy depends on the selected route, congestion level, road profile, weather condition, as well as other information available through global position system (GPS), Intelligent Transportation Systems (ITS), Geographical Information Systems (GIS), and traffic modelling [6], [7]. In this respect, emerging connected vehicles and wireless technology could undoubtedly mark a watershed.

This paper provides a comprehensive collection and survey on the recent PHEV EMS literature, with the overarching goal to systematically summarize the state-of-the-art of PHEV EMSs and explore research trends in the context of synergies of ITS, smart grid, and smart city. In contrast to previous papers, it avoids the classification into groups, (on/off)line global/local optimization, which can be sometimes misleading due to possible algorithms modifications and assumptions taken for implementation. Instead, each algorithm is individually introduced and evaluated, highlighting its strengths,

Clara Marina Martínez, Dongpu Cao and Efstathios Velenis are with the Advanced Vehicle Engineering Centre, Cranfield University, Cranfield, MK43 0AL, UK (c.m.marina@cranfield.ac.uk, d.cao@cranfield.ac.uk, e.velenis@cranfield.ac.uk). (*Corresponding authors are X. Hu and D. Cao.)

Xiaosong Hu is with the State Key Laboratory of Mechanical Transmissions and also with the Department of Automotive Engineering, Chongqing University, Chongqing, 400044, China (xiaosonghu@iecc.org).

Bo Gao and Matthias Wellers are with AVL Powertrain UK Ltd., Basildon, SS15 6LN, UK (bo.gao@avl.com, matthias.wellers@avl.com).

weaknesses, including alternative methods to compensate for them. Three prominent contributions differentiate our articles from the previous ones [8], [9]. First, we review nearly all the optimization-based PHEV EMSs to date, especially covering the most recently proposed methods, e.g., convex programming (CP), game theory (GT), and numerous metaheuristic algorithms. It also includes plentiful examples of their applications in simulation environment, which evidences the importance of these novel algorithms in research trend nowadays. Second, we survey the interactions of PHEV EMSs with ITS and highlight the great significance of predictive EMSs cognizant of environmental conditions outside the vehicle. Finally, we preview potential research prospects from a multitude of perspectives, which, along with ITS interaction analysis, are main contributions, not included in such depth in prior review papers. Although significant progress has been made, the current state-of-the-art has reached a level where novel transformative approaches are much desired to advance this field. This survey seeks to stimulate such innovative thoughts.

The remainder of the paper is arranged as follows. Section II gives an overview of PHEV EMSs. Section III focuses on optimization-based EMSs. The interactions of EMSs with ITS are discussed in Section IV, followed by an outlook for further research opportunities presented in section V. Conclusions are summarized in Section VI.

II. OVERVIEW OF PHEV EMSs

HEVs EMS is currently a well-proved technology. These vehicles have limited charging capability, reduced-size batteries, and consequently operate within a small state of charge (SoC) window. With a core task of assisting in ICE load shifting, EMSs in HEVs target equal initial and final SoC values, known as charge sustaining (CS) operation. HEVs EMS can be readily extended to PHEVs via charge depleting – charge sustaining (CD – CS) mode [10], [11]. This strategy is featured by its simplicity and ease of implementation, however, once the vehicle switches into CS, PHEV margin for improvement disappears [11]. Several publications have claimed the limited efficiency of CD – CS [12]. Its lack of optimality is addressed in simulation environment by Sun *et al.* [13], where the fuel efficiency is improved by 22.17% through deterministic dynamic programming, provided that the vehicle speed profile is available. Some detractors of CD – CS also alluded to the electric efficiency reduction under high power during the intensive CD mode. Zhang *et al.* [14] claimed an improvement of 9% in the fuel efficiency using reduced power strategies in a power-split configuration. In addition, CD – CS may require a relatively large battery so as to generate satisfying fuel economy, incurring augmented vehicle cost.

The alternative approach is gradual battery depletion along the drive cycle using Blended Mode (BM). This consists of the cooperation of ICE and EM during the whole trip, not reaching full battery depletion until the end. Analysis of BM strategies can be found in [15]–[18]. A comparison between CD-CS and BM in terms of the battery SoC evolution is depicted in Fig. 1.

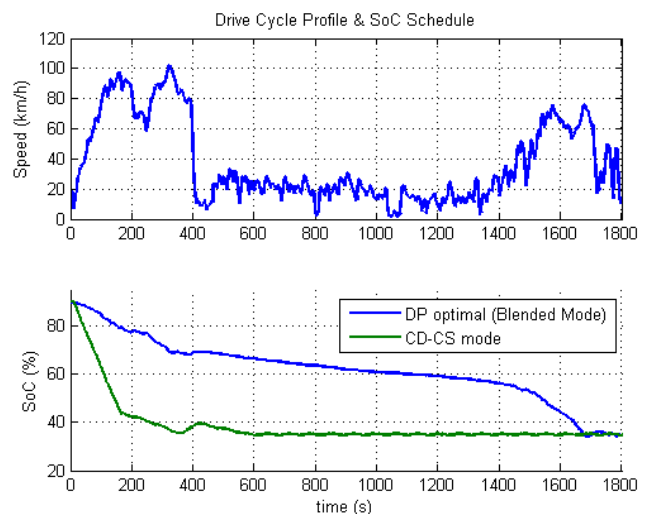

Fig. 1. Comparison between CD-CS strategy and optimal solution.

Nevertheless, it is worth mentioning that BM strategies have to be tuned for the trip length; longer trips result in premature battery drain, whereas shorter ones leave unused charge in the battery. In absence of trip information, BM could even develop worse results compared with a well-tuned CD – CS strategy [14], [19], [20], one of the main issues that prevents from BM implementation onboard. However, in contrast to CD – CS, it provides considerable improvement in fuel economy and fully exploits PHEVs beneficial properties, assuming availability of the required information [8], [21].

With independence from BM or CD – CS, EMSs are usually divided into two principle groups, rule-based (RB) and optimization-based strategies [8], [22]. The former includes deterministic strategies and fuzzy logic (FL), which are described as a set of rules that compute the control signals based on pre-established thresholds over the controlled variables. These thresholds are often calculated based on the analysis of optimal control policies obtained from selected drive cycles [10], [17]. The rules define the vehicle operating modes [11], [23], are easy to implement and understand, and their performance for low levels of hybridization is often acceptable. The previous are the main reasons for RB popularity in HEVs in industry [24]. Such advantages have encouraged their adaptation from HEVs to PHEVs [25]. However, they generally yield non-optimal control in real-life driving conditions, as they are devised for a particular set of drive cycles. Their drawbacks have been evidenced through simulation in [15] and [26] by comparing them with optimization-based EMSs. Fair comparisons, however, are only applicable, if a certain level of drive cycle information is available, which is generally not the case in real-life.

A higher level of abstraction is provided by FL. This strategy is still based on pre-defined rules which are implemented in a map-based format allowing for a wider margin of improvement. FL has been extended from HEVs to PHEVs, in terms of EMS and battery management in [27]. Several strategies have attempted a combination between FL and optimal solutions so as to improve the FL performance and maintain low computation burden. Some examples are

neuro-FL [28] and FL, combined with genetic algorithm [29] and evolutionary algorithm [30].

Albeit some of the former approaches are suitable for low levels of electrification, optimization-based strategies are proved to be superior to RB approaches. Nevertheless, they are also associated with additional implementation issues, e.g., algorithm complexity, high computation effort, robustness, and sensitivity to drive cycle information and characteristics, main reasons of their slow integration in industry. Nonetheless, a plethora of optimization-based algorithms has been applied to EMSs in PHEVs, mainly in simulation environment in research. These are classified into global (non-causal) optimization and real-time (causal) optimization [31]. Their distinction is not always clear, as they are conditioned not only by the algorithm itself, but also by sample time, model accuracy, and parameters definition, among other factors. The main optimization algorithms encompass Dynamic Programming (DP) [32], equivalent consumption minimization (ECMS) [33], simulated annealing (SA), genetic algorithm (GA), particle swarm optimization (PSO), DIRECT method [34], neural networks (NN) [35], game theory (GT) [36], sliding mode control (SMC), convex programming (CP) [37], analytical simplifications of the previous algorithms, and model predictive control framework. Their main characteristics and examples applied to PHEV EMS are elaborated in the next section.

III. OPTIMIZATION-BASED EMSS FOR PHEVS

This section provides a comprehensive survey of the state-of-the-art of optimal PHEV EMSs, including the main approaches considered in the literature to date.

A. Dynamic Programming (DP)

DP is an algorithm able to compute global optimal solutions in general control problems. The optimal solution is achieved by minimizing an unwanted outcome considering present and future cost of control decisions. This cost function, J , for DP deterministic implementation (DDP) can be expressed as [3], [32]:

$$J = \sum_{k=0}^{N-1} g_k(x_k, u_k, w_k) + g_N(x_N) \quad (1)$$

where g_N represents terminal cost, g_k is additive cost incurred at time k , and X , U and W denote system states, control decision and disturbances, respectively [32], [38]. The optimal cost to go of the initial step, $J^0(x_0)$, is calculated backwards from $N-1$ to 0, starting with end cost $g_N(x_N)$ and iterating:

$$J_k(x_k) = \min_{u_k \in U_k(x_k)} \{g_k(x_k, u_k, w_k) + J_{k+1}(f_k(x_k, u_k, w_k))\}. \quad (2)$$

In contrast to enumeration methods, DP computational advantage lies in the decomposition of the problem into sub-problems, which are easier to solve and require less

computational cost. Sub-problems optimality is guaranteed through the principle of optimality (PO): “*optimal policies have optimal subpolicies*” [39]. These are solved using multiple-state decision making processes, and possible solutions are studied via selecting only optimal combinations, which reduces searching space and thus calculation time [39]. It is applicable to varied domains, including non-linear constraint dynamic processes and integer problems, and it can manage several complex constraints applied to states and inputs [3], [40] – [42].

Nonetheless, the algorithm itself is not easily tractable, as it usually engenders numerical hazards, and its computational burden increases exponentially with the number of states and control variables. This syndrome is called as “curse of dimensionality”, which is an entrenched property of the Bellman’s principle [42]. Furthermore, assuming that the full information of the problem uncertainties is available prior to the solution calculation, DDP computes the optimization backwards, from the end to initial conditions. This mechanism seriously prohibits DDP from real-time automotive control, since drive cycle information is often only partly known, highly changeable, and vulnerable to strong disturbances [3], [43]. As a result, DDP is widely utilized in offline analysis to benchmark alternative EMSs, inspire RB strategies design, tune control parameters, and serve as training data for machine learning algorithms [3], [44], as well as gear shifting optimization, trip time reduction, *etc.*[44], [45].

Examples of DDP optimal results used as training material for NN-based EMSs can be found in [16] and [46]. Likewise, DDP was used by Lin *et al.* to obtain implementable rules for EMS and gearshift optimization in a hybrid truck [40] and [47]. An investigation of the optimal EMS for a fuel-cell hybrid is provided in [42], and gearshift control optimization is assessed in [7], [40], [48]. Alternatively, its online application could be achieved with simplified models, integrated with cycle preview capability [44]. Li *et al.* [7] proposed a future speed prediction algorithm based on NN and certain cycle information, which enables DP-based optimization of a transit plug-in hybrid electric bus. A DDP online application for commonly driven drive cycles was detailed by Larsson *et al.* [41], where the cost-to-go is calculated offline and feedforward to the online controller using a local polynomial approximation. Primary implementation issue of DDP can be tackled using stochastic dynamic programming (SDP), which replaces the disturbance vector by a random Markov process, thus independent from previous k values, not requiring future trip information. The cost function in SDP is hereby reformulated as expected cost in statistical terms [3]:

$$J = E_{w_k} \left[\sum_{k=0}^{N-1} g_k(X_k, U_k, w_k) + g_N(X_N) \right]. \quad (3)$$

SDP follows the same algorithm as DDP with expected cost [3]. This approach was suggested to reduce drive cycle dependency in [49] and [50] for PHEV EMSs. Shortest path stochastic dynamic programming (SP-SDP) was used by Opila

et al. in [51] and later in [52], with real-time implementation eased by extensive offline computations, stored in tables.

B. Equivalent Consumption Minimization Strategy (ECMS)

ECMS was first introduced by Paganelli *et al.* in [53], [33] with the purpose of reducing fuel consumption in a hybrid parallel powertrain. It consists of the calculation of an equivalence fuel factor, which accounts for actual fuel consumed, fuel consumed to recharge batteries, and fuel saved by using energy recovered through regenerative braking. This represents the fact that electricity accumulated in the battery is not “free” when proceeding from the engine recharging mode, and allows for unifying fuel and electricity consumption in a single objective [43],[53].

$$\min \left(\sum_{t=1}^N \dot{m}_{feq}(t) \right) \quad \forall t \quad (4)$$

$$\dot{m}_{feq}(t) = \dot{m}_f(t) + \dot{m}_{fem}(t) = \dot{m}_f(t) + s(t) \frac{P_{batt}(t)}{Q_{LHV}} \quad (5)$$

where N , \dot{m}_{feq} , \dot{m}_f , \dot{m}_{fem} , s , P_{batt} , Q_{LHV} and t are, respectively, trip duration, equivalent fuel flow, actual fuel flow into ICE, equivalent fuel flow used by the EM, fuel equivalence factor, battery power, fuel lower heating value, and time step [43],[53]. ECMS was initially designed for HEVs operating in CS mode, using the equivalence factor to prevent from sudden battery depletion [12], [43]. In PHEVs, this strategy targets, instead, CD mode, and consequently the SoC reference is not a fixed value, but a scheduled battery depletion along the trip.

ECMS is derived using the Pontryagin’s minimum principle (PMP) optimality conditions, which return a local optimization algorithm. PMP assumptions and equations derivation can be found in [53], [54], [55], and [43], which includes Lagrange multipliers. These simplifications result in an algorithm more computationally efficient than DP and well-suited for potentially online applications, which can generate controllers close to global optimal solution with appropriate tuning of the equivalence factor. This is, however, not straightforward, thanks to its high sensitivity to drive cycle characteristics [43].

ECMS has proved to outperform RB in a simulation environment [15]. Triboli *et al.* used PMP results to inspire a RB strategy, also validated through simulation, comparing it to CD – CS and conventional powertrain [17]. An application of ECMS to PHEV is described by Stockar *et al.*, who obtained the optimal equivalence factor through offline iterations, studying its influence in CD – CS vs. BM [54]. However, ECMS on-line implementation requires further reduction of the computational time. This issue is addressed by the same authors, who proposed solving the Hamiltonian offline, and storing the optimal results in a map so as to facilitate its use online [43]. Further simplifications have been introduced to explore regular patterns in the solution, which allow for PMP approximation using piecewise linear equations in [18]. Fuel equivalence factor online tuning is achieved by Musardo *et al.* through an adaptive ECMS (A-ECMS), which is able to automatically modify the parameter based on trip information

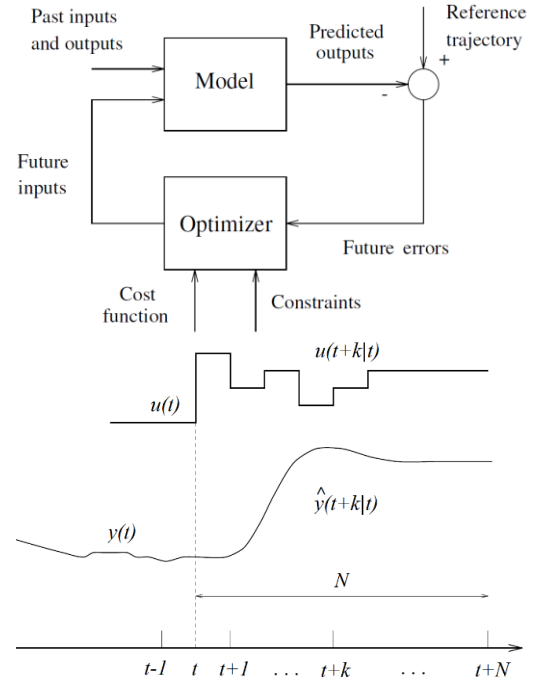

Fig. 2. MPC basic problem structure (top) and single iteration of MPC algorithm (bottom) [57].

with periodical online updates [56]. Similarly, Tianheng *et al.* presented an A-ECMS using NN to predict future cycle demand in [6].

C. Model Predictive Control (MPC)

As already mentioned, trip information is critical to EMSs in PHEVs. MPC offers such a predictive scheme that future cycle information can be incorporated into various EMSs [57]. Its operation comprises four main steps: 1) prediction over a fixed horizon with length N , which depends on the historical data recorded and system model; 2) control policy calculation from t to $t+N$ based on the previous prediction; 3) application of the control policy calculated for the current instant t , discarding the rest; 4) update with real measurements at t , and return to Step 1. Using fast control algorithms in step 2 is particularly recommended due to MPC iterative computations [24]. Fig. 2 illustrates the MPC framework and one iteration step.

The algorithm performance relies on model quality, sampling step, and prediction horizon length. The horizon length has to be tuned accordingly with: control strategy used, computational effort, model accuracy, and external conditions and disturbances [57]. MPC can be also combined with GPS information, improving the prediction results by means of past, present, and future driving conditions [58].

ECMS would benefit from additional drive cycle information through predictive algorithms such as MPC. It can be used to tune systematically the parameters, which will be less dependent on the drive cycle. Furthermore, MPC does not require full information of the drive cycle, as it happened with DD. Instead, the prediction horizon and implementation of faster algorithms, such as quadratic programming (QP), allow for its potential application in real-time control [24]. This framework was used by Sun *et al.*, who proposed a two level EMS using traffic information, MPC and NN, for long and

short term forecast [13]. Borhan *et al.* used QP in [24], and a PMP in a later publication, easing MPC computational burden [59]. A Lagrange multipliers derivation is detailed by Kermani *et al.* in [60], where the functions are approximated by maps and embedded into MPC framework. Using the same principle as in SDP, Ripaccioli *et al.* proposed a stochastic MPC approach, which models driver demand as a Markov process, and reduces the computational effort implementing QP when compared to SDP [61].

D. Derivative Free Algorithms

Derivative-free methods mainly concern metaheuristic algorithms inspired in nature and DIRECT deterministic method, which is detailed in part 4 in this subsection. They are utilized to solve optimization problems with large search space of likely solutions. The main metaheuristic algorithms employed by (P)HEV EMSs are simulated annealing, genetic algorithms, and particle swarm optimization [26], [34], [62], [63]. These algorithms do not require derivative calculations, but harness alternative methods to populate candidates for optimal solution. This solution search depends on certain parameters that facilitate getting rid of local minima, although convergence to global optima cannot be generally ensured [64].

1) Simulated Annealing (SA)

SA is a method inspired in the annealing process of metals. The solution is searched through a stochastic technique which takes the solution candidates that show improvement over the objective function, but also keeps suboptimal ones which still agree with a defined criterion. This characteristic prevents the algorithm from being trapped in local minima and enhances its evolution towards global optimal [62], [65]. The solution variability is controlled by the “temperature” of the iteration and rated using the objective function. The temperature decreases with the number of iterations, “cooling down” effect, evolving from global to local optimal search [62], [65]. New solutions are only accepted when meeting the Boltzman criterion with monotonically decreasing temperature parameter:

$$p' < \exp\left(\frac{-\Delta E}{T}\right); \text{ with } T[k+1] = \alpha \cdot T[k] \quad (6)$$

where p' , ΔE , T , and α , are a random uniformly distributed value [0 1], comparison between current and candidate solution, temperature of the iteration, and cooling parameters, respectively. SA is relatively easy to implement and provides satisfactory results with low computation burden, which makes it feasible for real-time applications [34], [65]. It was developed to solve combinatorial problems, generating competitive solutions when compared with DP in limited simulation time [64], [66]. It can also be readily extended to continuous optimization problems. SA trade-off between accuracy and calculation time can be controlled by termination conditions, which are usually expressed in terms of limited iterations and accepted tolerance [62], [64], [66].

An example of SA application to hybrids control is presented by Wang *et al.*, who developed an EMS for a series HEV. The simulation results showed convergence improvement when compared to DIRECT method for a fixed number of iterations [67]. SA is combined with RB to develop the EMS of an EV with two electrical power sources, battery and supercapacitor. Long-term energy management is determined using RB providing a reduced search space, whilst short term power management optimization is performed with SA. The results are validated in simulation environment in [64] and later in [65]. Chen *et al.* derived an EMS based on PMP for a PHEV and leveraged SA to search for optimal engine-on power and maximum current coefficient, easing the computation for random driving conditions [66]. Its convergence capabilities were upgraded by combining SA with GA in [68]. This hybrid algorithm took advantage of robust global convergence of GA in earlier stages, and reduced later phases runtime using SA. Similarly, SA and PSO convergence deficiencies are compensated by combining both algorithms to form a so-called PSOSA in [69].

2) Genetic Algorithm (GA)

GA is a stochastic method inspired on natural selection and genetic evolution, and a particular case of evolutionary algorithms. It consists of three phases: reproduction, crossover information, and mutation, which involve randomness so as to ensure population diversity. In each of the iterations, the solution is coded in simulated “chromosomes”. Then the best candidates are selected according to the objective (fitness value) and deployed to populate the next set of solutions following the previously listed steps. The process eventually converges to “the best solution”, a satisfying trade-off between computational effort and precision [62], [70], [71]. However, owing to limited runtime, this algorithm may deliver sub-optimal solutions and does not explicitly enforce constraints, which need to be considered in the form of penalty functions introduced into the fitness function, F [71].

$$F(x) = \frac{1}{J(x)} + \sum_{i=1}^{n_{con}} \alpha_i \cdot P_i(x) \quad (7)$$

where $J(x)$, α_i , and $P_i(x)$ are, respectively, objective function, positive constant penalization, and penalty function for i^{th} constraint, being $J(x)$ maximized whilst $F(x)$ minimized in order to penalize for constraints violation. This algorithm provides good performance even when dealing with complex problems. Furthermore, it only saves current states and last population, requiring low memory resources. It is also compatible with a broad variety of models, such as linear and nonlinear models with continuous or discontinuous-time form. One of the main strengths of GA, compared to other optimization strategies, is the capacity of parallelism detection between different agents, which is particularly beneficial to computing Pareto solutions. It can also include elitism to make sure that the best solutions are passed to next iterative step without major changes [62].

GA is sometimes combined with other algorithms to improve the combined performance. Chen *et al.* [70] used GA to optimize the engine power in a power-split PHEV, whilst the optimal battery current was calculated using QP, provided that the model was expressed in quadratic terms. The parallelism property was exploited by Bashash *et al.*[72], where GA was adopted to optimize two conflicting objectives, i.e., energy cost and battery health in a PHEV. GA was also applied to a parallel HEV energy management to minimize fuel consumption, along with emissions [71].

3) Particle Swarm Optimization (PSO)

PSO was introduced for the first time in 1995 by Kennedy, and Eberhart. It is inspired in the behaviour of social organism moving in groups, such as swarms, ant colonies, and bird flocking, which share information within the members. PSO is also considered as a particular case of evolutionary algorithms, thanks to the solution population characteristic similar to the crossover mechanism in GA. This algorithm populates particles states, position, and velocity. Particles can interact locally between each other with the purpose of interchanging information, and can store their last best position and group best solution, with the goal of improving the next population. The convergence behaviour depends on previous calculated solutions and particles velocity [34], [69], [73]. All particles update their position, x_d^i , and velocity, v_d^i , according to [73]:

$$v_d^i(k+1) = wv_d^i(k) + c_1 \cdot r_1 \cdot (pBest_i(k) - x_d^i(k)) + \dots \quad (8)$$

$$c_2 \cdot r_2 \cdot (gBest(k) - x_d^i(k)) \quad (9)$$

$$x_d^i(k+1) = x_d^i(k) + v_d^i(k+1) \quad (9)$$

where i denotes each particle, $pBest$ and $gBest$ are particle and global best-found location, and w , c_1 , c_2 , r_1 , and r_2 are inertia weight, two positive constants, and two random parameters within $[0, 1]$, respectively. Maximum and minimum velocity values are constraint within $\pm v_d^{\max}$. PSO is robust to complex objective functions and merely requires population of two variables per particle (i.e., position and velocity), and iteration. The small number of tuning parameters facilitates its implementation and reduces its sensitivity to initial solutions, when compared to other metaheuristic optimization algorithms [34], [69], [73]. The basic PSO algorithm can be adapted to accept problems with constraints, as detailed by Hu *et al.* [74].

A comprehensive comparison of derivative-free algorithms, SA, GA, PSO, and DIRECT, was carried out in [34]. These algorithms were compared, in terms of fuel consumption, vehicle performance, and computational characteristics, for a fixed number of iterations. The results identified PSO and GA as winning approaches, with PSO being slightly superior [34]. PSO performance can be enhanced by defining bounds in search scope inspired on “experience” over the best solutions. Nevertheless, despite a probable accuracy, the convergence speed is limited [75]. The online applications of PSO as EMS for PHEV was analysed by Lin *et al.* [76]. Satisfactory results were obtained with a long simulation time, making its online

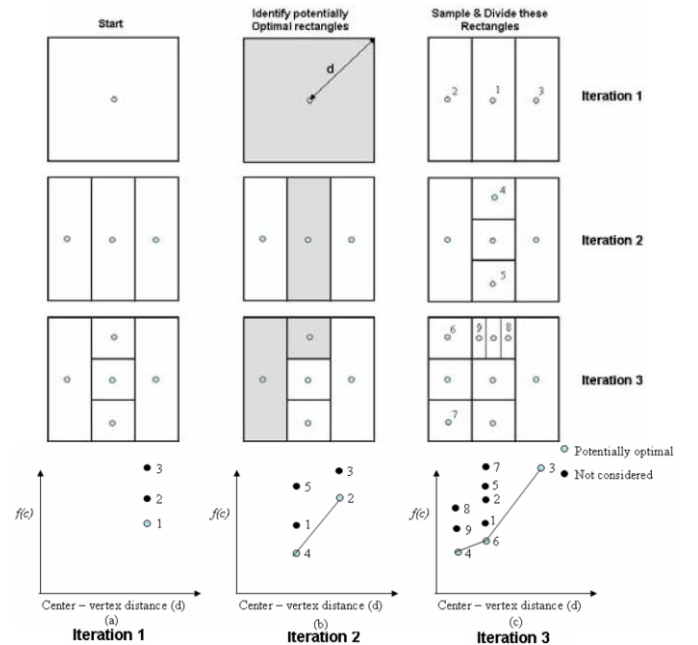

Fig. 3. Representation of three iterations of DIRECT method [26].

implementation difficult. The authors defended the necessity of faster algorithms to obtain a real-time controller from near-optimal PSO results. This issue was addressed in the case study using PSO in combination with a neural network.

4) DIRECT Method

Divided RECTangle (DIRECT) is a sampling derivative-free method, a modification of the standard Lipschitzian algorithm, where the weights of local and global search are equal. DIRECT scales the searching space into fixed areas with cubic shapes, and searches for optimal solutions at the centre point of each area. The best solutions are identified, and resampled following the longest coordinate direction of each cubic division. The algorithm completes until termination distance conditions are reached, which can be expressed in terms of solution accuracy and/or number of iterations. The result’s suitability is rated through a cost function [26], [34]. Fig. 3 illustrates three iterations of DIRECT method.

Compared to other metaheuristic optimization algorithms, DIRECT is relatively simpler, as it does not require tuning parameters and can handle both equality and inequality constraints. Moreover, it is robust in the presence of nonlinearities and disturbances [26], [34]. Several applications of DIRECT method to HEV EMSs can be found in the literature, including Rousseau *et al.* [26] who used the Powertrain System Analysis Toolkit (PSAT) to design an EMS with tuneable variable thresholds. DIRECT method was applied to determine the most influencing parameters and their optimal values to design a RB for a set of drive cycles. Gao *et al.* analysed DIRECT performance by contrasting it with other derivative-free approaches in simulation environment for HEV fuel consumption reduction subjected to constraints on vehicle performance, which has been already referenced in PSO [34]. Whitefoot *et al.* used DIRECT to minimize fuel consumption in a HEV in offline investigation. The algorithm ran for a fixed number of iterations in order to procure controllable

computational burden, but it did not allow to evaluate the global optimality of solution. Therefore, this paper elucidated an offline implementation of DIRECT, without allusions to likely online applications [77]. DIRECT limitations for real-time applications are also revealed in [78]. The authors highlighted the capability of finding regions with local/global optimum solutions, but argued the necessity of considerable time to converge into a solution with a small error tolerance.

E. Neural Networks (NNs)

NNs perform brain-like computations inspired in biological brain behaviour, namely, operations emulating neurons activities as natural systems. As appeared in biological brains, each neuron receives impulses from other neurons through their dendrites. These signals are processed in the neuron's body, and depending on inputs characteristics, an output signal is generated, which is sent to other neurons. Fig. 4 shows an example of a neuron that processes the weighted input signals,

$\sum_{i=0}^n w_i x_i$, and returns the result sign, y , with respect to a threshold, t . Neurons undertake affine transformation and linear/non-linear operations in a very efficient fashion. These operations are usually expressed with transfer functions [35], [79]. Neurons can be combined so as to create networks by building layers, usually using feed-forward configurations (see Fig. 5). The number of layers and neurons can vary according to the process complexity, desired fidelity, and model nonlinearity. This architecture has to be defined prior to the neuron parameters calculation, which is always conducted using training data and the error back-propagation algorithm [46], [62], [76], [79].

The training data can be labelled with the desired output when the strategy to follow is clear, if the process is well known and understood. However, it is also possible to work with unlabelled data, which requires additional pattern recognition. The error convergence in NN is enhanced using error backpropagation, which targets to optimize the reduction of training error [35], [62]. The training process consists of least-squares regression, where the initial values of dendrites weights are assigned randomly [62], [79]. The amount and quality of training directly influence the NN performance, e.g., overfitting risk. However, there exists an optimal amount of training data, and therefore excess training does not always imply the performance improvement [62], [76]. NNs are easily implemented and can develop surrogated models of the underlying processes. These models can reproduce complex behaviour with high fidelity and low computation burden, the so-called "intelligent decision making". Furthermore, NNs are treated as black box and no additional understanding of the process physics is required for its utilization [62]. Nonetheless, while a well-trained NN efficiently extrapolates solutions, this is not always guaranteed when the use cases are not contemplated on the training data.

Applications of NNs to automotive purposes are supported by the statement included in [46], which affirms: "The algorithms that require iterations are not convenient for hybrid vehicle power distribution problem". Khayyam *et al.* [28]

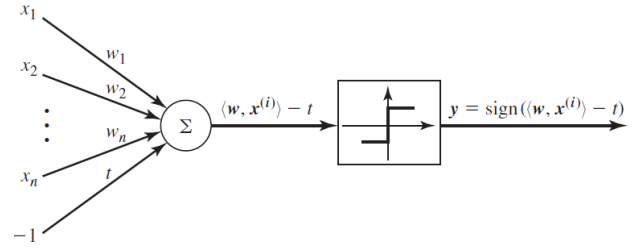

Fig. 4. Example of neuron body with multiple inputs, affine operation, and single output [35].

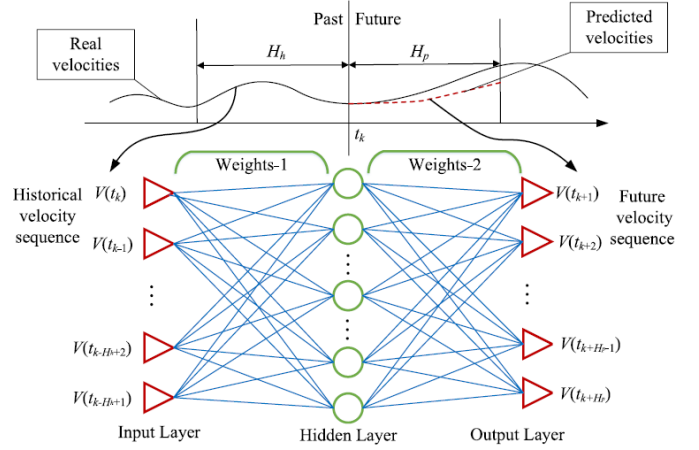

Fig. 5. Example of NN structure for future speed prediction, including input, hidden, and output layer, as well as prediction level in terms of past and future information [13].

proposed NN application in "hybrid multi-layer adaptive neuro-fuzzy inference". This algorithm provided learning characteristics to the FL controller so as to adapt and increase its application range, which can automatically tune its values. The authors defended the importance of finding a trade-off between algorithm performance and information requirements, through analysing the influence of road, environmental conditions, and driver behaviour. Following the previous reasoning, Chen *et al.* [16] also supported the need of intelligent controllers that pursue a good trade-off between computational effort and algorithm robustness for a wider range of use cases. The authors employed NN to minimize the fuel consumption of a PHEV, based on training data from DP results of varied driving conditions. The NN consisted of two different modules, N_1 and N_2 , which worked with different levels of trip information. Murphey *et al.* [80], [81] presented a power-split HEV EMS based on machine learning also trained with DP optimal results. This strategy combined road type and congestion level prediction, and used NNs to optimize battery power and engine speed. Likewise, Boyali *et al.* [46] developed a neuro-DP approach for HEV, where again the NN was trained with DP solutions. The resultant controller was also able to operate in real-time and exhibited parallel computation capabilities validated through simulation. Alternatively, Lin *et al.* [76] synthesized a NN controller trained with data generated using PSO. Other NNs applications concern their combinations with other algorithms to diminish computational effort. For instance, Sun *et al.* incorporated NN into MPC over a short-term prediction horizon [13]. The same authors also presented a future speed prediction algorithm based on machine

learning including Markov Chain and NN. They claimed to obtain 92% fuel optimality using NN-based predictor, when compared to MPC benchmark solution using DP in simulation environment [82].

F. Game Theory (GT)

GT deals with the interaction between decision-makers, also known as players. The players pursue defined objectives and are considered as agents with self-interest. GT is inspired by the main characteristics describing ordinary games, which typically involve various players, a set of rules, and a number of allowable strategies. These available actions have an associated payoff, which rates how beneficial or detrimental the “movement” for each player is. The game itself only describes what the players can do, but not the ultimate actions, in the same way the model equations constrain the variables feasible values [36], [83], [84]. Every strategy followed by one player generates a benefit for the named agent and a loss for the rest, the so-called payoff. It is assumed that each player acts rationally towards the action that maximizes its own payoff, and the game evolves towards the steady-state case, where no player has any incentive to change its state. This is known as a Nash Equilibrium, a non-unique situation usually difficult to reach which does not necessarily represent the fairest outcome for all players [83]–[85]. Considering a two-player non-cooperative game with follower and leader feasible strategies $u \in U$ and $w \in W$, respectively, the players tend to achieve in each stage a Stakelberg equilibrium (marked by *), described as [85]

$$J(u^*, w^*) = \max_{w \in W} \min_{u \in U} J(u, w) \quad (10)$$

Games can be classified in two groups depending on players’ behaviour with respect to other players. On the one hand, games are “non-cooperative” when the players take individual actions so as to maximize their own payoff. On the other hand, games are “cooperative” when the actions are taken to maximize group objectives. One example of non-cooperative game could be the interaction between driver and powertrain. This can be understood as the competition between the conflicting objectives, e.g., driver desired performance and fuel economy. Alternatively, the cooperation of ICE and EM, with the purpose to maximize their combined performance and fuel saving, represents a cooperative game [36]. The most common game in the literature for EMSs is two-player non-cooperative. Dextreit *et al.* [85], [86] applied this approach between driver and powertrain, to develop the EMS for an HEV Jaguar Land Rover Freelander 2. The driver intention was to obtain the desired vehicle performance, which resulted in inefficient working conditions, whilst the powertrain itself targeted fuel consumption optimization. This application highlights one of the main benefits of GT, which is the consideration of the driver as a part of the control strategy, anticipating that the driving style is intimately coupled with fuel consumption. The GT-based EMS was also compared to DP and MPC, showcasing its benefit with respect to the system robustness in simulation environment. GT can be implemented with receding

horizon in the same way as MPC, however its computation burden can be comparable to DP, even when it uses simpler equations. This makes its online implementation difficult in vehicular applications. Some authors have tackled this problem with model simplifications through static maps and vector-based integration, which develop time- and drive cycle-independent strategies [85], [86]. A similar application of GT was described by Gielniak *et al.* for a fuel cell hybrid electric vehicle [87]. The game was again described by conflicting interests, i.e., powertrain efficiency versus vehicle performance. The authors underlined the fact that GT requires deep knowledge of the system elements and consequently cannot be extrapolated to other vehicles with different components. This constitutes one of the main drawbacks. GT had further applications for PHEVs to develop optimal charging strategies, “smart charging”, as detailed by Mohsenian-Rad *et al.* [88] and Sheikhi *et al.* [89].

G. Sliding Mode Controller (SMC)

SMC is an algorithm inherently robust to nonlinearity and modelling uncertainty, which can efficiently work with system structures that alternatively switch. It is also insensitive to parameters change and disturbances, a salient characteristic that makes it useful for vehicular applications [19], [90]. This strategy requires the definition of a sliding surface, $s(x)$, also known as switching function. The controller $u(t)$ is usually the same as $s(x)$ and designed to converge to the surface, $s(x) = 0$, in finite time, and to maintain its position, ‘reaching condition’. This is designed in the form of:

$$u_i(t) = \begin{cases} u_i^+(t), & \text{for } s_i(x) > 0 \\ u_i^-(t), & \text{for } s_i(x) < 0 \end{cases}; i = 1, 2, \dots, m; u_i^+(t) \neq u_i^-(t). \quad (11)$$

The complexity and performance of SMC depends on the sliding surface design. Consequently, the mathematics involved in this algorithm can be relatively complicated, in contrast with most of the foregoing approaches. Gokasan *et al.* [19], [90] developed a SMC-based controller to manage a series HEV with all-wheel-drive (AWD) for military purposes. This controller responded to the necessity of a robust solution to nonlinear, time-variant systems surrounded by parameters variation and external disturbances. Its robustness also allowed the use of simpler vehicle models. However, the applications of SMC have been more dominant in combustion engines control within hybrid powertrains, rather than EMSs on its own. There is a case of Gokasam *et al.* [90] who exploited SMC to improve engine operation conditions for optimizing the overall HEV efficiency, followed by [91] discussing a similar application to EMS design.

H. Convex Programming (CP) and Analytic Solutions

Due to the complexity of vehicle models, the aforementioned EMSs have to deal with mathematical difficulties, such as nonlinearity, various constraints, and computation burden. Some literatures also explore simplifying techniques to ease the implementation issues of EMSs, including linearization, QP,

TABLE I
MAIN EMS CHARACTERISTICS AND APPLICATIONS SUMMARY

Strategy	Main Advantages	Main Disadvantages	Applications offline ⁽¹⁾ control	Applications online ⁽²⁾ control
DP	Global optimal–benchmark (PO)	Curse of dimensionality Full cycle info (not in SDP)	[7] [16] [40] [42] [44] [46] – [48]	[41] [49] [50] – [52]
ECMS	Single obj. – equivalence factor Possible online implementation	Cycle sensitivity (adaptive) Local opt. for deficient tuning	[15], [17], [54]	[6], [18], [43], [56]
D. Free	Stochastic solution generation: escape from local optima Few tunable parameters Control over terminal conditions	Acceptable accuracy requires high no. iterations	[26], [34], [67] – [69], [71], [72], [75], [77], [78]	[64] – [66], [70], [76]
NN	Fast computation – online control	Accuracy: training data quality and quantity Uncertain solution outside training cases	[28]	[16], [46], [80], [81]
GT	Trade-off conflicting objectives Driver introduction into EMS	Curse of dimensionality Non-unique solution	[85] – [87]	(Map-based [85], [86])
SMC	Robust to uncertainties Robust to parameters change	Complex mathematics: $s(x)$	[90], [91]	–
CP	Reduced computational effort	Strong model simplifications	[94], [96]	[66], [72], [93], [95], [98] [101]–[105]

⁽¹⁾ When no allusion to real-time control is made by the authors; ⁽²⁾ As claimed by the authors including detailed assumptions and validated in simulation environment

CP, and analytical equations derivation. These formulations are amenable to powerful solvers available, which typically extract optimal solutions in reduced time and potentially increase the solution robustness. The quality of solution is, however, compromised by declined model fidelity after simplifications, thereby attaining near-optimal results [92].

CP is a generalization of linear programming (LP) and QP. In CP problems, local optima coincide with global optima, simplifying extensively the search of solution. Nevertheless, the algorithm can only be applicable when the problem is strictly expressed in convex terms, which requires both cost function and inequality constraints expressed in convex form, and affine equality constraints [37], [93]. Convex vehicle models need to be simplified to comply with convexity requirements [10]: 1) eliminate integer decisions: engine on/off, gear shift, etc.; 2) equality constraints must be relaxed, if they are originally not affine; 3) use new variables to preserve convexity, such as battery energy instead of SoC; and 4) problem coding in discrete-time. The formal definition of a convex function, f , is described as [93]

$$f(\theta x + (1-\theta)y) \leq \theta f(x) + (1-\theta)f(y), \quad 0 \leq \theta \leq 1 \quad (12)$$

where x and y are two points of the f function space. Numerous CP applications to (P)HEV EMSs have been reported in the recent literature. Zhang *et al.* [14] dealt with an analytical solution for the power management of a PHEV, where the vehicle model is simplified using quadratic equations. The solution provided a simulation error of 3.0%. Egardt *et al.* [93] improved PMP performance via expressing the cost function in convex terms and approximating the model with quadratic expressions. Nevertheless, the model equations required convenient reformulation following convexity rules, which compromised its accuracy. Another analytical solution for PMP was proposed by Serrao *et al.* [94]. Hu *et al.* designed two EMSs based on convex optimization so as to study

fuel-to-traction and recuperation energy efficiencies in a series plug-in hybrid electric bus [95]. Beck *et al.* presented two approaches for a real-time adaptive EMS with QP optimization. Both solutions were compared in simulation environment with the offline DP benchmark, demonstrating commensurate optimality with a significant decrease in computational time [96]. A similar strategy was followed by Koot *et al.*, where the authors used a QP problem formulation and DP as a benchmark [97]. The diminution of the strategy complexity not only encourages its real-time implementation, but also permits integrating new variables into the optimization, e.g., catalyst air temperature to reduce poisonous emissions [98], battery health [71], [72], and fuel cell health [99], [100]. CP has also been successfully implemented for EMS in a PHEV with a continuously variable transmission, which eliminates gearshift integer variable [101]. Furthermore, CP efficient computation enables increasing the number of system states and control variables for offline holistic studies, including EMS between others [102]–[105].

CP main limitation, nevertheless, lies in the formulation of an appropriate vehicle model. For instance, switch decisions cannot be optimized in the CP problem, and consequently the optimal gear shift cannot be easily pursued with high accuracy [18]. Sciarretta *et al.* [58] proposed a simplification of objective function for an HEV EMS, reaching a possible analytic solution to the optimization problem. However, the authors found limited applications of such an algorithm, owing to strong assumptions over the battery SoC.

All the foregoing EMS approaches are straightforwardly summarized in Table I, in terms of main characteristics and application examples.

IV. EMS INTERACTIONS WITH ITS

As demonstrated in most optimization-based EMSs mentioned in Section III, future trip information is of utmost importance for reducing fuel consumption in PHEVs [9]. Taking the most pessimistic but probably realistic situation of

no future trip information into account, Huang *et al.* proposed a predictive algorithm based on machine learning, which uses 150s of past cycle information to predict the next 50s of vehicle speed [106]. Although there is a relationship between current and future velocities, real-world cycles are, nonetheless, characterized by a certain level of randomness and strong disturbances due to traffic conditions. This has motivated growing research on EMSs with entire trip information [107] or with robustness to different levels of trip knowledge. As elaborated in [20], trip information is typically classified into four levels: 1) full information about distance, velocity, and road profile; 2) information about distance and road profile, along with estimated velocity; 3) trip distance; and 4) no information.

The increasing popularity of smart phones promotes vehicles with GPS, wireless connection, and real-time traffic conditions, which can be obtained, for example, using Google services. Such information, combined with MPC, was exploited by Sun *et al.* [13] who developed a two-level controller for EMS of a power-split PHEV. Real-time traffic information was absorbed to perform a long-term planning at a supervisory level so as to accomplish the optimized reference SoC trajectory. This trajectory was then tracked at a lower level using MPC-optimized short-term engine torque and speed, given the availability of short-term velocity prediction provided by a NN forecaster [13]. Several other examples of EMS incorporating GPS information and route knowledge were shown in [9]. The importance of GPS and GIS information for global PHEV optimization was also showcased in [8].

In recent years, an escalation in research initiatives has been observed to promote intelligent EMSs conscious of external environmental conditions, like trip knowledge. Gong *et al.* [19], [108] examined the impact of ITS information on the PHEV fuel consumption with the objective to find the relationship between vehicle performance and velocity profile, through a statistical analysis of drive cycle. In a previous publication, the authors also underscored the value of interplay among ITS, GIS, GPS, and traffic flow modelling. Historical data and real-time information were fused to provide enough information for EMSs optimization through global methods [109].

A different approach is proposed by Ozatay *et al.* who targeted cloud-based future speed optimization for a group of vehicles [110]. The optimization was performed within three servers with “unlimited” resources. These received data from several vehicles, containing full information of traffic and road conditions. This data is used to compute optimal strategies, which were fed back to the driver serving as guideline. As the computational burden is generally not an issue in the cloud, DP can be utilized to assure global optimality. Accordingly, the vehicle can be exempted from expensive ECU capacity and thus its cost can be reduced. Moreover, this also allows for using more accurate models and extending the results to different drivers in similar conditions. Ozatay *et al.* concluded with vehicle test results displaying a fuel reduction in highway driving of 14.1%, when the reference velocity was perfectly followed, and approximately 7.4% in urban driving, given

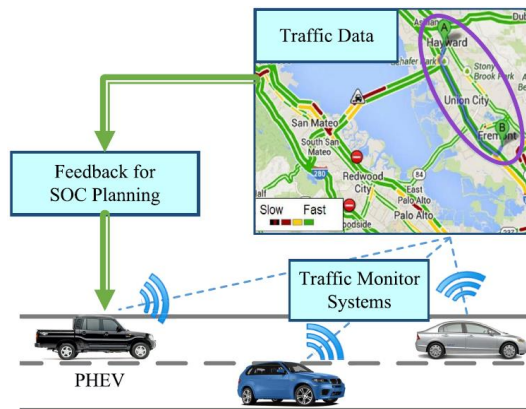

Fig. 6. Connected vehicle framework with interchange of information with a traffic data base (figure is extracted from [13]).

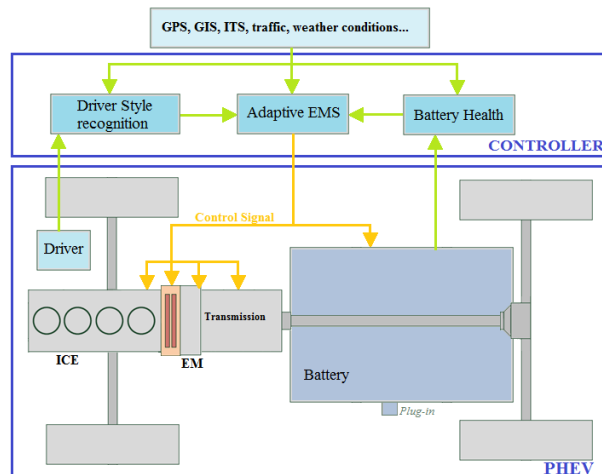

Fig. 7. Connected PHEV framework. It is able to receive information from ITS, GPS, GIS, etc., and combine internal signals measured so as to compute an adaptive control strategy.

driver corrections [110]. Fig. 6 illustrates a similar approach, where vehicles driving in the same route shared and received information from the data base. Fig. 7 discloses the key procedures taking place internally in the vehicle control system.

A comprehensive study of the major impact factors on fuel consumption was provided by Marano *et al.* in [111], with a particular emphasis on the weather conditions, including temperature and wind direction effects on rolling and aerodynamic resistance. Besides the clear importance of traffic conditions for fuel consumption, the way the driver faces the driving task has also a major effect. Reichart *et al.* [112] claimed more than 16% improvement in fuel consumption after intervening in driver’s driving style, while obtaining only 3% time penalty over the drive cycle execution in a conventional vehicle platform, according to simulation results. As a matter of fact, driver monitoring and driver style correction can improve noticeably fuel economy, as confirmed by Syed *et al.*, where 27.85% improvement in fuel efficiency by correcting driver driving style is observed in real-time simulation [113]. Driving style correction can be particularly critical to (P)HEVs, as small deviations in the torque demand can incur significant changes in the EMS, triggering, for instance, ICE starting. A detailed evaluation of driving-style influence on different vehicle platforms, BEVs, HEVs, and PHEVs, was conducted by

Neubauer *et al.* on a vehicle simulator in [114].

Optimal vehicle speed profile can be obtained combining trip information and driving style so as to guide drivers for minimal fuel consumption. However, it necessitates a good coordination of different sources, extensive data processing, and heavy computational burden. Consequently, on-board computational capability can be a limiting factor in this respect. With the latest research tendencies, vehicles are advocated to be considered as a part of a larger group which can be optimized at a higher scale. Cloud computing and ITS systems can ease the computational stress on-board, and provide an overall fleet optimization [9], [110]. Furthermore, this could set a useful framework for increased vehicle automation towards autonomous driving.

V. OUTLOOK AND FUTURE TRENDS

There has been a wealth of efforts on PHEV EMSs, including both rule- and optimization-based ones as revisited in Sections II – IV. As a prosperous area of research, various innovative strategies are expected to emerge for enhancing the performance, public acceptance, and market penetration of PHEVs, instead of just repeating a number of existing approaches. Further research opportunities will definitely gain considerable momentum from the advancement of optimization algorithms, ITS, smart grid, smart city, and other cyber-physical systems. In the following, we briefly but nontrivially discuss the future trends of PHEV EMSs from different perspectives, which could substantially contribute to safer, greener, and cheaper vehicles.

A. Optimization Algorithms

As elucidated in Section III, each optimization algorithm has its own strengths and limitations, a key reason why there has been no consensus technique to address the EMS problem. Consequently, a mixture of optimization algorithms with complementary characteristics is a promising direction of PHEV EMSs. For example, Elbert *et al.* combined CP with PMP to successfully optimize both the ICE on/off signal and power split in a series hybrid transit bus. PMP analytically obtains the ICE on/off strategy, which is then used, along with convex optimization, to compute the optimal solution. This combination allows for the introduction of integer variable optimization within the convex framework [115]. Similarly, Nüesch *et al.* combined DP with CP to resolve a mixed integer EMS optimization problem, which allows integrating engine on/off and gearshift into the convex optimization [116]. Such integer variables are pre-calculated over the entire drive cycle to enable expressing the optimization problem as convex terms. Panday *et al.* presented a synergy between GA and PMP. In this case, PMP received optimal parameter values from GA and used them to calculate the optimal strategy [117]. More such combinations could be anticipated in the near future.

In parallel with the previous work, optimization itself represents a vast area of research. Novel optimization algorithms are continually emerging, some of which are expected to solve PHEV EMS problems with certain unique advantages, e.g., pseudospectral method [118] and hybrid

optimal control law [47]. In addition, machine learning (data-driven optimization) is a rapidly growing area and provides numerous advanced learning techniques, e.g., NN, support vector machine, Bayesian inference, and reinforcement learning [119]. These could be integrated into the current PHEV EMSs to strengthen their autonomy and environmental consciousness. For instance, reinforcement learning has been recently successfully implemented in applications related to buses commuting within the same route [120].

B. Consideration of Additional Model Dynamics and Cycle Information

Quasi-static powertrain models had a prevalent adoption in synthesizing PHEV EMSs, because of their simplicity and fast computation. However, the results from simulation and real-test inevitably differ. To bridge the gap, dynamic models are welcome, such as transients-involved ICE models [111] and polarization-covered battery models [121]. Furthermore, PHEV have intense battery use and grid impact, comparable to battery electric vehicles. This fact needs to be addressed with appropriate battery models able to provide more realistic behaviour [122], including extreme temperature working conditions and cold temperature operation [123]. The concomitant challenge is that some computationally intensive optimization algorithms may not be directly applicable.

Another key requirement for optimal vehicle operation is the available trip information. This is pursued through exploiting commuting trips, bus pre-established routes, and predictive algorithms, including MPC and machine learning. These algorithms have been used to develop the so-called adaptive strategies that update the parameter values of control strategies according to the route characteristics, e.g., A-ECMS [6], [96], [124]. Nevertheless, trip information needs to be acquired through additional instrumentation installed onboard, and consumes computational effort and memory resources, increasing the vehicle cost.

C. Multiple Control Objectives

Most of existing PHEV EMSs concentrated on a single control objective, i.e., fuel consumption minimization. However, many other design concerns should be considered as well, including: drivability for comfort [34], [71]; battery health for cost effectiveness [49], [72], [94]; emissions for eco-driving (which can be critical when PHEVs have minimum engine use and delay optimum exhausts temperature conditions [13],[18], [49], [98], [125]); ICE and battery thermal properties for safety; global CO₂ emission including electricity generation [111]; *etc.*

Incorporating some of such targets to enable multi-objective PHEV EMSs is one of the future research directions. One main challenge is how to achieve high-fidelity models depicting such concerns, e.g., battery degradation and thermal models suitable for PHEV operation. Battery health models considered in the existing (P)HEV EMSs are generally too simple to capture both capacity and power fading [66], [100]. Additional objectives also cause a significantly heavier computational burden. Accordingly, the difficulty of efficiently generating credible Pareto solutions arises [92]. Alternatively, the objective functions can be simplified either with single objective function

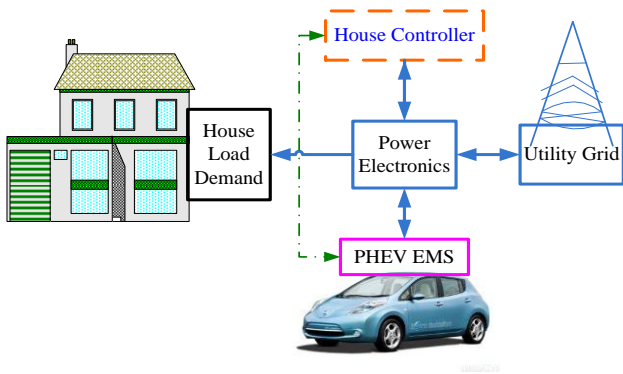

Fig. 8. PHEV EMS in a longer time scale, e.g., 24-hour energy management including on-road driving and charging/discharging during parked (grid-to-vehicle, vehicle-to-grid, and vehicle-to-house modes). The house controller and PHEV EMS can communicate each other, in order to coordinate energy utilization in driving and parking.



Fig. 9. Optimization of EMSs considering multi-scale space and time via connecting PHEVs with traffic, grid, and buildings (figure is taken from [9]).

combined with constraints over “less important” targets, or through objectives weighted combination into one function [71]. On the one hand, the first approach returns sub-optimal results over the constraint targets. On the other hand, weighted objectives optimality is questioned by the selection of weight values [92]. Despite that multi-objective approaches have been addressed using CP, it is worth developing more computationally efficient optimization algorithms to compensate deficiencies of the current ones.

D. Longer Time Scale

The revisited EMSs were evaluated under a single drive cycle or several concatenated cycles. Hence, the time scale considered was for merely on-road driving and relatively short. Nonetheless, there will be increasing interactions between PHEVs, smart house, and smart grid, with the development of smart meters and communication technology. As sketched in Fig. 8, this incentivizes a longer time-scale (e.g., 24-hour) EMS problem, which manages energy utilization in both driving and parking. First assessment of combined recharging and on-road energy management in PHEVs was provided in [102], [126]. More complicated PHEV activities are definitely worth careful considerations in further research, like vehicle-to-grid and vehicle-to-house energy flows, subject to the intermittency of

renewables, and developing a new research stream, e.g., “smart PHEVs charging”.

E. Larger Space Scale

Traditionally, PHEV EMSs were evaluated at a single vehicle level, and therefore, the space scale was relatively limited. With the continual development of smart devices, vehicle-to-vehicle (V2V), and vehicle-to-infrastructure (V2X) communication technologies, there will be increasing connected PHEVs (see Fig. 9) and vehicle platooning, in the drive to increase road capacity and overall energy efficiency [127]. The platooning concept is usually associated with groups of heavy duty vehicles, where the longitudinal dynamics are controlled to reduce inter-vehicular distance [128]. However, it is also applicable to groups of light duty vehicles sharing route and schedules. Platooning will be developed along with the vehicular ad-hoc network (VANET), wireless environment closely related with ITS where data can be adequately exchanged [129]. Some examples of this tendency are already present in the literature. Baisravan *et al.* exploited vehicle connectivity advantages to develop an EMS for a group of HEVs. The authors proposed a two-level strategy, where the higher level controller benefits from shared information from smart traffic lights, V2X, and neighbours vehicles through V2V communication [130]. Likewise, Rios-Torres *et al.* targeted the reduction of fuel consumption and trip duration through online coordination of connected vehicles in merging road manoeuvres using PMP [131].

The EMS problem of such a fleet of PHEVs might be markedly different from the case of a single PHEV, due to spatial distribution, intra-vehicle communication/control, surrounding perturbation, and so forth. These unique attributes can strongly motivate innovative and even revolutionary PHEV EMS paradigms, e.g., multi-agent cooperative EMS, cooperative look-ahead EMS, distributed MPC-based EMS, and many other advanced networked EMSs. Further, the level of vehicle connection will bolster a gradual introduction of increasing levels of automation. Luo *et al.* proposed an addition of V2V communication to safely perform lane change for normal and emergency cases, and returning to lane [132]. Similarly, Morales Medina *et al.* introduced a cooperative autonomous T-intersection control based on V2V communication with virtual platoons of vehicles [133]. Nevertheless, real-time traffic, ITS data, GPS, etc., assume a burdensome amount of information required to achieve optimal Situation Awareness (SAW), critical to ensure safety in VANET [134], which will become a thriving area of research.

VI. CONCLUSIONS

This review on PHEVs EMSs algorithms highlights strengths and weakness of virtually all the existing approaches in the open literature. It does not conclude with a single algorithm preferred for PHEVs energy management, but advocates mixing more than one to compensate for each own deficiencies. Nevertheless, it has been evidenced that the EMS cannot be really optimized unless detailed information about the future route is available. Since strong uncertainties

surrounding driving experience hinder accurate predictions, augmented vehicular connectivity and evolution towards increasing levels of autonomy will mark a watershed for fuel consumption reduction and strategy optimization. Such a new era will be presumably led by information and big data, and is highly probable to be advanced by means of machine learning as a common framework.

REFERENCES

- [1] European Commission. Transport and Environment. Euro V & Euro VI panel report. <http://ec.europa.eu/environment/air/transport/road.htm>; last time visited 21st January 2015.
- [2] Hoog, R. (2014), Life beyond Euro VI, Automotive Megatrends Magazine, Q2, pp. 66-67.
- [3] Guzzella, L. and Sciarretta, A. (2007), Vehicle propulsion systems (Vol. 1), Springer-Verlag Berlin Heidelberg.
- [4] Salisa, A. R., Zhang, N., and Zhu, J. G. (2011), A comparative analysis of fuel economy and emissions between a conventional HEV and the UTS PHEV, IEEE Transactions on Vehicular Technology, Vol. 60, pp. 44-54.
- [5] Raghavan, S. S., and Khaligh, A. (2012), Electrification potential factor: Energy-based value proposition analysis of plug-in hybrid electric vehicles, IEEE Trans on Vehicular Technology, Vol. 61, pp. 1052-1059.
- [6] Feng, T., Yang, L., Gu, Q., Hu, Y., Yan, T., and Yan, B. (2013), A supervisory control strategy for plug-in hybrid electric vehicles based on energy demand prediction and route preview, IEEE Transactions on Vehicular Technology, Vol. 64, No. 5, pp. 1691-1700.
- [7] Li, L., Yang, C., Zhang, Y., Zhang, L., and Song, J. (2015), Correctional DP-based energy management strategy of plug-in hybrid electric bus for city-bus-route, IEEE Trans on Vehicular Technology, 64, pp. 2792-2803.
- [8] Wirasingha, S. G., and Emadi, A. (2011), Classification and review of control strategies for plug-in hybrid electric vehicles, IEEE Transactions on Vehicular Technology, Vol. 60, No. 1, pp. 111-122.
- [9] Malikopoulos, A. (2014), Supervisory power management control algorithms for hybrid electric vehicles: a survey, IEEE Transactions on Intelligent Transportation Systems, Vol. 15, No. 5, pp. 1869-1885.
- [10] Gao, Y. and Ehsani, M. (2010), Design and control methodology of plug-in hybrid electric vehicles, IEEE Transactions on Industrial Electronics, Vol. 57, No. 2, pp. 633-640.
- [11] Gonder, J. and Markel, T. (2007), Energy management strategies for plug-in hybrid electric vehicles, SAE Technical Paper.
- [12] Tulpule, P., Marano, V., and Rizzoni, G. (2009), Effects of different PHEV control strategies on vehicle performance, American Control Conference, pp. 3950-3955.
- [13] Sun, C., Moura, S. J., Hu, X., Hedrick, J. K., and Sun, F. (2014), Dynamic traffic feedback data enabled energy management in plug-in hybrid electric vehicles, IEEE Transactions on Control Systems Technology, Vol. 23, No. 3, pp. 1075-1086.
- [14] Zhang, M., Yang, Y., and Mi, C. C. (2012), Analytical approach for the power management of blended-mode plug-in hybrid electric vehicles, IEEE Transactions on Vehicular Technology, Vol. 61, pp. 1554-1566.
- [15] Sciarretta, A., Serrao, L., Dewangan, P. C., Tona, P., Bergshoeff, E. N. D., Bordons, C., and Wu, M. (2014), A control benchmark on the energy management of a plug-in hybrid electric vehicle. Control Engineering Practice, Vol. 29, pp. 287-298.
- [16] Chen, Z., Mi, C. C., Xu, J., Gong, X., and You, C. (2014), Energy management for a power-split plug-in hybrid electric vehicle based on dynamic programming and neural networks, IEEE Transactions on Vehicular Technology, Vol. 63, No. 4, pp. 1567-1580.
- [17] Tribioli, L., Barbieri, M., Capata, R., Sciubba, E., Jannelli, E., and Bella, G. (2014), A real time energy management strategy for plug-in hybrid electric vehicles based on optimal control theory, Energy Procedia, Vol. 45, pp. 949-958.
- [18] Hou, C., Ouyang, M., Xu, L., and Wang, H. (2014), Approximate pontryagin's minimum principle applied to the energy management of plug-in hybrid electric vehicles, Applied Energy, Vol. 115, pp. 174-189.
- [19] Gong, Q., Li, Y., and Peng, Z. R. (2008), Trip-based optimal power management of plug-in hybrid electric vehicles, IEEE Transactions on Vehicular Technology, Vol. 57, No. 6, pp. 3393-3401.
- [20] Zhang, C. and Vahidi, A. (2012), Route preview in energy management of plug-in hybrid vehicles, IEEE Transactions on Control Systems Technology, Vol. 20, No. 2, pp. 546-553.
- [21] Larsson, V., Johannesson, L., Egardt, B., and Larsson, A. (2012), Benefit of route recognition in energy management of plug-in hybrid electric vehicles, American Control Conference, pp. 1314-1320.
- [22] Zhang, P., Yan, F., and Du, C. (2015), A comprehensive analysis of energy management strategies for hybrid electric vehicles based on bibliometrics, Renewable and Sustainable Energy Reviews, 48, pp. 88-104.
- [23] Zhang, B., Mi, C. C., and Zhang, M. (2011), Charge-depleting control strategies and fuel optimization of blended-mode plug-in hybrid electric vehicles, IEEE Trans on Vehicular Technology, Vol. 60, pp. 1516-1525.
- [24] Borhan, H. A., Vahidi, A., Phillips, A. M., Kuang, M. L., and Kolmanovsky, I. V. (2009), Predictive energy management of a power-split hybrid electric vehicle, American Control Conference, pp. 3970-3976.
- [25] Ghorbani, R., Bibeau, E., and Filizadeh, S. (2010), On conversion of hybrid electric vehicles to plug-in, IEEE Transactions on Vehicular Technology, Vol. 59, No. 4, pp. 2016-2020.
- [26] Rousseau, A., Pagerit, S., and Gao, D. W. (2008), Plug-in hybrid electric vehicle control strategy parameter optimization, Journal of Asian Electric Vehicles, Vol. 6, No. 2, pp. 1125-1133.
- [27] Li, S. G., Sharkh, S. M., Walsh, F. C., and Zhang, C. N. (2011), Energy and battery management of a plug-in series hybrid electric vehicle using fuzzy logic, IEEE Trans on Vehicular Technology, 60, pp. 3571-3585.
- [28] Khayyam, H. and Bab-Hadiashar, A. (2014), Adaptive intelligent energy management system of plug-in hybrid electric vehicle, Energy, Vol. 69, pp. 319-335.
- [29] Poursamad, A. and Montazeri, M. (2008), Design of genetic-fuzzy control strategy for parallel hybrid electric vehicles, Control Engineering Practice, Vol. 16, No. 7, pp. 861-873.
- [30] Wang, A. and Yang, W. (2006), Design of energy management strategy in hybrid vehicles by evolutionary fuzzy system part I: Fuzzy logic controller development, IEEE In Intelligent Control and Automation, Vol. 2, pp. 8324-8328.
- [31] Salmasi, F. R. (2007), Control strategies for hybrid electric vehicles: Evolution, classification, comparison, and future trends, IEEE Transactions on Vehicular Technology, Vol. 56, No. 5, pp. 2393-2404.
- [32] Bertsekas, D. P., (1995), Dynamic programming and optimal control, Vol. 1, No. 2.
- [33] Paganelli, G., Delprat, S., Guerra, T. M., Rimaux, J., and Santin, J. J. (2002), Equivalent consumption minimization strategy for parallel hybrid powertrains, IEEE In Vehicular Technology Conference, Vol. 4, pp. 2076-2081.
- [34] Gao, W. and Mi, C. (2007), Hybrid vehicle design using global optimisation algorithms, International Journal of Electric and Hybrid Vehicles, Vol. 1, No. 1, pp. 57-70
- [35] Lathi, B. P. (1973), Signal, Systems, and Controls. In text.
- [36] Osborne, M. L., and Rubinstein, A. (1994), A course in game theory (chapters 1&2), Massachusetts Institute of Technology.
- [37] Boyd, S., and Vandenberghe, L. (2004), Convex optimization, Cambridge university press.
- [38] Bellman RE (1957) Dynamic programming. Princeton University Press, Princeton
- [39] Lew, A. and Mauch, H. (2007), Dynamic programming. A Computational Tool, Springer
- [40] Lin, C. C., Peng, H., Grizzle, J.W., and Kang, J.M. (2003), Power management strategy for a parallel hybrid electric truck, IEEE Transactions on Control Systems and Technology, Vol. 11, pp. 839-849
- [41] Larsson, V., Johannesson, L., and Egardt, B. (2014), Analytic Solutions to the Dynamic Programming subproblem in Hybrid Vehicle Energy Management, IEEE Trans on Vehicular Technology, 64, pp.1458-1467.
- [42] Ansarey, M., Panahi, M.S., Ziarati, H., and Mahjoob, M. (2014), Optimal energy management in a dual-storage fuel-cell hybrid vehicle using multi-dimensional dynamic programming, Journal of Power Sources, Vol. 250, pp. 359-371.
- [43] Stockar, S., Marano, V., Canova, M., Rizzoni, G., and Guzzella, L. (2011), Energy-optimal control of plug-in hybrid electric vehicles for real-world driving cycles, IEEE Transactions on Vehicular Technology, 60, pp. 2949-2962.

- [44] Zhang, C., Vahidi, A., Pisu, P., Li, X., and Tennant, K. (2010), Role of terrain preview in energy management of hybrid electric vehicles, *IEEE Transactions on Vehicular Technology*, Vol. 59, No. 3, pp. 1139-1147.
- [45] Liu, J. and Peng, H. (2006), Control optimization for a power – split hybrid vehicle, *IEEE American Control Conference*, pp. 466-471.
- [46] Boyali, A. and Güvenç, L. (2010), Real-time controller design for a parallel hybrid electric vehicle using neuro-dynamic programming method, *IEEE Conf on Systems Man and Cybernetics*, pp. 4318-4324.
- [47] Lin, C. C., Peng, H., Grizzle, J. W., Liu, J., and Busdiecker, M. (2003), Control system development for an advanced-technology medium-duty hybrid electric truck, *SAE Technical Paper*.
- [48] Sundström, O., Soltic, P., and Guzzella, L. (2010), A transmission-actuated energy-management strategy, *IEEE Transactions on Vehicular Technology*, Vol. 59, No. 1, pp. 84-92.
- [49] Kum, D., Peng, H., and Bucknor, N.K. (2010), Supervisory control of parallel hybrid electric vehicles for fuel and emission reduction, *ASME Journal of Dynamic Systems, Measurement, and Control*, 133.
- [50] Lin, C.C., Peng, H., and Grizzle, J.W. (2004), A stochastic control strategy for hybrid electric vehicles, *American Control Conference*, Vol. 5, pp. 4710-4715.
- [51] Opila, D. F., Wang, X., McGee, R., and Grizzle, J. W., (2013), Real-Time Implementation and Hardware Testing of a Hybrid Vehicle Energy Management Controller Based on Stochastic Dynamic Programming, *Journal of Dynamic Systems, Measurements, and Control*, Vol. 135, no. 2.
- [52] Opila, D. F., Wang, X., McGee, R., Gillespie, R. B., Cook, J. A., and Grizzle, J. W., (2014), Real-World Robustness for Hybrid Vehicle Optimal Energy Management Strategies Incorporating Drivability Metrics, *Journal of Dynamic Systems, Measurement, and Control*, Vol. 136, No. 6.
- [53] Paganelli, Gino, et al. (2001), General supervisory control policy for the energy optimization of charge-sustaining hybrid electric vehicles, *JSAE*, Vol. 22, No. 4, pp. 511-518.
- [54] Stockar, S., Marano, V., Rizzoni, G., and Guzzella, L. (2010), Optimal control for plug-in hybrid electric vehicle applications, *American Control Conference*, pp. 5024-5030.
- [55] Serrao, L., Onori, S., and Rizzoni, G., (2009), ECMS as a realization of Pontryagin's minimum principle for HEV control, *American control conference*, pp. 3964-3969.
- [56] Musardo, C., Rizzoni, G., Guezennec, Y., and Staccia, B. (2005), A-ECMS: an adaptive algorithm for hybrid electric vehicle energy management, *European Journal of Control*, Vol. 11, No. 4-5, pp. 509-524.
- [57] Camacho, E. and Bordons, C. (2007), Model predictive control (chapters 1&2), *Advanced Textbooks in Control and Signal Processing*, Springer, 2nd Edition.
- [58] Sciarretta, A. and Guzzella, L. (2007), Control of hybrid electric vehicles, *IEEE Control Systems*, vol. 27, no. 2, pp. 60-70.
- [59] Borhan, H., Vahidi, A., Phillips, A.M., Kuang, M.L., Kolmanovsky, I.V., and Di Cairano, S. (2012), MPC-based energy management of a power-split hybrid electric vehicle, *IEEE Transactions on Control Systems Technology*, Vol. 20, No. 3, pp. 593-603.
- [60] Kermani, S., Delprat, S., Guerra, T. M., and Trigui, R. (2009), Predictive control for HEV energy management: experimental results, *IEEE Vehicle Power and Propulsion Conference*.
- [61] Ripaccioli, G., Bernardini, D., Di Cairano, S., Bemporad, A., and Kolmanovsky, I. V. (2010), A stochastic model predictive control approach for series hybrid electric vehicle power management, *American Control Conference*, pp. 5844-5849.
- [62] Koziel, S. and Yang, X.-S. (2011), *Computational optimization, methods and algorithms*, Springer.
- [63] Marinakis, Y., Marinaki, M. and Dounias, G. (2010), A hybrid particle swarm optimization algorithm for the vehicle routing problem, *Engineering Applications of Artificial Intelligence*, Vol. 23, pp. 463-472.
- [64] Trovão, P. J., Pereirinha, P. G., Jorge, H. M., and HenggelerAntunes, C. (2013), A multi-level energy management system for multi-source electric vehicle – An integrated rule-based meta-heuristic approach, *Applied Energy*, vol. 105, pp. 304-318.
- [65] Trovão, J.P.F., Santos, V.D.N., Pereirinha, P.G., Jorge, H.M., and Antunes, C.H. (2013), A simulated annealing approach for optimal power source management in a Small EV, *IEEE Transaction on Sustainable Energy*, Vol. 4, No. 4, pp. 867-876.
- [66] Chen, Z., Mi, C. C., Xia, B., and You, C. (2014), Energy management of power-split plug-in hybrid electric vehicles based on simulated annealing and Pontryagin's minimum principle, *Journal of Power Sources*, Vol. 272, pp. 160-168.
- [67] Wang, Z. and Li, W. (2007), Optimization of series hybrid electric vehicle operational parameters by simulated annealing algorithm, *IEEE International Conference on Control and Automation*, pp. 1536-1541.
- [68] Hui, S. (2010), Multi-objective optimization for hydraulic hybrid vehicle based on adaptive simulated annealing genetic algorithm, *Engineering Applications of Artificial Intelligence*, vol. 23, pp. 27-33.
- [69] Chen, K., Deng, Y., Zhou, F., Sun, G., and Yuan, Y. (2011), Control strategy optimization for hybrid electric vehicle based on particle swarm and simulated annealing algorithm, *IEEE International Conference on Electric Information and Control Engineering*, pp. 2054-2057.
- [70] Chen, C., Mi, C. C., Xiong, R., Xu, J. and You, C. (2014), Energy management of a power-split plug-in hybrid electric vehicle based on genetic algorithm and quadratic programming, *Journal of Power Sources*, Vol. 248, pp. 416-426.
- [71] Montazari-Gh, M., Poursamad, A., and Ghalichi, B. (2006), Application of genetic algorithm for optimization of control strategy in parallel hybrid electric vehicles, *Journal of The Franklin Institute*, Vol. 343, pp. 420-435.
- [72] Bashash, S., Moura, S. J., Forman, J. C., and Fathy, H. K. (2011), Plug-in hybrid electric vehicle charge pattern optimization for energy cost and battery longevity, *Journal of Power Sources*, Vol. 196, No. 1, pp. 541-549.
- [73] Wu, J., Zhang, C.H., and Cui, N.X. (2008), PSO algorithm-based parameter optimization for HEV powertrain and its control strategy, *International Journal of Automotive Technology*, Vol. 9, No. 1, pp. 53-69.
- [74] Hu, X. and Eberhart, R. (2002), Solving constrained nonlinear optimization problems with particle swarm optimization, *6th World Multiconference on Systematics, Cybernetics and Informatics*.
- [75] Nüesch, T., Ott, T., Ebbesen, S., and Guzzella, L. (2012), Cost and fuel-optimal selection of HEV topologies using particle swarm optimization and dynamic programming, *American Control Conference*, pp. 1302-1307.
- [76] Lin, X., Banvait, H., Anwar, S., and Chen, Y. (2010), Optimal energy management for a plug-in hybrid electric vehicle: real-time controller, *American Control Conference*, pp. 5037-5042.
- [77] Whitefoot, J. W., Ahn, K., and Papalambros, P. Y. (2010), The case for urban vehicles: powertrain optimization of a power-split hybrid for fuel economy on multiple drive cycles, *International Design Engineering Technical Conferences and Computers and Information in Engineering Conference*, American Society of Mechanical Engineers, pp. 197-204.
- [78] Markel, T., and Wipke, K. (2002), Vehicle system impacts of fuel cell system power response capability, *SAE International*.
- [79] Karrenberg, U. (2007), *signals, processes, and systems. An interactive multimedia introduction to signal processing*, Springer 3rd Edition.
- [80] Murphey, Y. L., Park, J., Chen, Z., Kuang, M. L., Masrur, M. A., and Phillips, A. M. (2012), Intelligent hybrid vehicle power control—Part I: Machine learning of optimal vehicle power, *IEEE Transactions on Vehicular Technology*, Vol. 61, No. 8, pp. 3519-3530.
- [81] Murphey, Y. L., Park, J., Kiliaris, L., Kuang, M. L., Masrur, M. A., Phillips, A. M., and Wang, Q. (2013), Intelligent hybrid vehicle power control—Part II: Online intelligent energy management, *IEEE Transactions on Vehicular Technology*, Vol. 62, No. 1, pp. 69-79.
- [82] Sun, C., Hu, X., Moura, S. J., and Sun, F. (2015), Velocity Predictors for Predictive Energy Management in Hybrid Electric Vehicles, *IEEE Transactions on Control Systems Technology*, Vol. 23, pp. 1197-1204.
- [83] Mohsenian-Rad, A. H., Wong, V. W., Jatskevich, J., Schober, R., and Leon-Garcia, A. (2010), Autonomous demand-side management based on game-theoretic energy consumption scheduling for the future smart grid, *IEEE Transactions on Smart Grid*, Vol. 1, No. 3, pp. 320-331.
- [84] Cigler, L. and Faltings, B. (2013), Decentralized Anti-coordination Through Multi-agent Learning, *Journal of Artificial Intelligence Research*, Vol. 47, pp. 441-473.
- [85] Dextreit, C. and Kolmanovsky, I.V. (2014), Game theory controller for hybrid electric vehicles, *IEEE Transactions on Control Systems Technology*, Vol. 22, No. 2, pp. 652-663.
- [86] Dextreit, C., Assadian, F., Kolmanovsky, I.V., Mahtani, J., and Burnham, K. (2008), Hybrid electric vehicle energy management using game theory, *SAE Technical Paper Series*.

- [87] Gielniak, M.J. and Shen, Z.J. (2004), Power management strategy based on game theory for fuel cell hybrid electric vehicles, *Vehicular Technology Conference*, Vol. 6, pp. 4422-4426.
- [88] Mohsenian-Rad, A. H., Wong, V. W., Jatskevich, J., Schober, R., and Leon-Garcia, A. (2010), Autonomous demand-side management based on game-theoretic energy consumption scheduling for the future smart grid, *IEEE Transactions on Smart Grid*, Vol. 1, No. 3, pp. 320-331.
- [89] Sheikhi, A., Bahrami, Sh, Ranjbar, A.M., and Oraee, H. (2013), Strategic charging method for plugged in hybrid electric vehicles in smart grids; a game theoretic approach, *Electrical Power and Energy Systems*, Vol. 53, pp. 499-506.
- [90] Wu, L., Shi, P., and Su, X. (2014), Sliding mode control of uncertain parameter-switching hybrid systems, John Wiley & Sons.
- [91] Gokasan, M., Bogosyan, S., and Goering, D. J. (2006), Sliding mode based powertrain control for efficiency improvement in series hybrid-electric vehicles, *IEEE Trans on Power Electronics*, 21, pp. 779-790.
- [92] Patil, R. M. (2012), Combined design and control optimization: application to optimal PHEV design and control for multiple objectives, Doctor of Philosophy dissertation, University of Michigan.
- [93] Egardt, B., Murgovski, N., Pourabdollah, M., and Mårdh, L. J. (2014), Electromobility studies based on convex optimization. design and control issues regarding vehicle electrification, *IEEE Control Systems Magazine*, Vol. 34, No. 2, pp. 32-49.
- [94] Serrao, L., Onori, S., Sciarretta, A., Guezennec, Y., and Rizzoni, G. (2011), Optimal energy management of hybrid electric vehicles including battery aging, *American Control Conference*, pp. 2125-2130.
- [95] Hu, X., Murgovski, N., Johannesson, L., and Egardt, B. (2013), Energy efficiency analysis of a series plug-in hybrid electric bus with different energy management strategies and battery sizes, *Applied Energy*, Vol. 111, pp.1001-1009.
- [96] Beck, R., Bollig, A., and Abel, D. (2007), Comparison of two real-time predictive strategies for the optimal energy management of a hybrid electric Vehicle, *IHP*, Vol. 62, No. 4, pp. 635-643.
- [97] Koot, M., Kessels, J. T., De Jager, B., Heemels, W. P. M. H., Van den Bosch, P. P. J., and Steinbuch, M. (2005), Energy management strategies for vehicular electric power systems, *IEEE Transactions on Vehicular Technology*, Vol. 54, No. 3, pp. 771-782.
- [98] Kum, D., Peng, H., and Bucknor, N. K. (2013), Optimal energy and catalyst temperature management of plug-in hybrid electric vehicles for minimum fuel consumption and tail-pipe emissions, *IEEE Transactions on Control Systems Technology*, Vol. 21, No. 1, pp. 14-26.
- [99] Hu, X., Marina Martinez, C., Egardt, B., and Cao, D. (2015), Multi-objective optimal sizing and control of fuel cell systems for hybrid vehicle applications, *European Control Conference*, pp. 2559-2564.
- [100] Hu, X., Johannesson, L., Murgovski, N., and Egardt, B. (2015), Longevity-conscious dimensioning and power management of the hybrid energy storage system in a fuel cell hybrid electric bus, *Applied Energy*, Vol. 137, pp. 913-924.
- [101] Murgovski, N., Johannesson, L. M., and Egardt, B. (2014), Optimal battery dimensioning and control of a CVT PHEV powertrain, *IEEE Transactions on Vehicular Technology*, Vol. 63, No. 5, pp. 2151-2161.
- [102] Hu, X., Moura, S., Murgovski, N., Egardt, B., and Cao, D. (2016), Integrated optimization of battery sizing, charging, and power management in plug-ion hybrid electric vehicles, *IEEE Transactions on Control Systems Technology*, Vol. 24, No. 3, pp. 1036-1043.
- [103] Hu, X., Marina Martinez, C., and Y, Yang. (2016), Charging, power management, and battery degradation mitigation in plug-in hybrid electric vehicles: A unified cost-optimal approach, *Mechanical Systems and Signal Processing*.
- [104] Hu, X., Murgovski, N., Johannesson, L. M., and Egardt, B. (2014), Comparison of three electrochemical energy buffers applied to a hybrid bus powertrain with simultaneous optimal sizing and energy management, *IEEE Trans. on Intelligent Transportation Systems*, Vol. 15, pp. 1193-1205.
- [105] Murgovski, N., Johannesson, L., Sjöberg, J., and Egardt, B. (2012), Component sizing of a plug-in hybrid electric powertrain via convex optimization, *Mechatronics*, Vol. 22, No. 1, pp. 106-120.
- [106] Huang, X., Tan, Y., and He, X. (2011), An intelligent multifeature statistical approach for the discrimination of driving conditions of a hybrid electric vehicle, *IEEE Transactions on Intelligent Transportation Systems*, Vol. 12, No. 2, pp. 453-465.
- [107] Hay, Y., Kuang, M., and McGee, R. (2014), Trip-oriented energy management control strategy for plug-in hybrid electric vehicles, *IEEE Transactions on Control Systems Technology*, Vol. 22, pp. 1323-1336.
- [108] Gong, Q., Tulpule, P., Marano, V., Midlam-Mohler, S., and Rizzoni, G. (2011), The role of ITS in PHEV performance improvement. *IEEE In American Control Conference*, pp. 2119-2124.
- [109] Gong, Q., Li, Y., and Peng, Z. R. (2007), Optimal power management of plug-in HEV with intelligent transportation system, *IEEE/ASME conference on in Advanced intelligent mechatronics*, pp. 1-6.
- [110] Ozatay, E., Onori, S., Wollaeger, J., Ozguner, U., Rizzoni, G., Filev, D., and Di Cairano, S. (2014), Cloud-Based Velocity Profile Optimization for Everyday Driving: A Dynamic-Programming-Based Solution, *IEEE Trans on Intelligent Transportation Systems*, 15, pp. 2491-2505.
- [111] Yan, F., Wang, J., and Huang, K. (2012), Hybrid electric vehicle model predictive control torque-split strategy incorporating engine transient characteristics, *IEEE Trans on Vehicular Technology*, Vol. 61, pp. 2458-2467.
- [112] Reichart, G., Friedmann, S., Dorrer, C., Rieker, H., Drechsel, E., and Wermuth, G. (1998), Potentials of BMW driver assistance to improve fuel economy, *World Automotive Congress*, Vol. 27, pp. 1-16.
- [113] Syed, F. U., Filev, D., Tseng, F., and Ying, H. (2009), Adaptive real-time advisory system for fuel economy improvement in a hybrid electric vehicle. *IEEE Annual Meeting of the North American in Fuzzy Information Processing Society*, pp. 1-7.
- [114] Neubauer, J. S. and Wood, E. (2013), Accounting for the Variation of Driver Aggression in the Simulation of Conventional and Advanced Vehicles, *SAE Technical Paper*.
- [115] Elbert, P., Nüesch, T., Ritter, A., Murgovski, N., and Guzzella, L. (2014), Engine on/off control for the energy management of a serial hybrid electric bus via convex optimization, *IEEE Transactions on Vehicular Technology*, Vol. 63, No. 8, pp. 3549-3559.
- [116] Opila, D. F., Wang, X., McGee, R., Gillespie, R. B., Cook, J. A., and Grizzle, J. W., (2014), Real-World Robustness for Hybrid Vehicle Optimal Energy Management Strategies Incorporating Drivability Metrics, *Journal of Dynamic Systems, Measurement, and Control*, Vol. 136, No. 6.
- [117] Panday, A., and Bansal, H. O., (2016), Energy Management Strategy implementation in Hybrid Electric Vehicles using Genetic Algorithm Tuned Pontryagin's Minimum Principle Controller. *International Journal of Vehicular Technology*, Volume 2016 (2016), Article ID 4234261, 13 pages.
- [118] Zou, W., Zhang, C., Li, J., and Fathy, H. K. (2015), A pseudospectral strategy for optimal power management in series hybrid electric vehicles, *IEEE Transactions on Vehicular Technology*.
- [119] Liu, T., Zou, Y., Liu, D., and Sun, F., (2015), Reinforcement Learning of Adaptive Energy Management With Transition Probability for a Hybrid Electric Tracked Vehicle, *IEEE Transactions on Industrial Electronics*, Vol. 62, No. 12, pp. 7837-7846.
- [120] Fang, Y., Song, C., Xia, B., and Song, Q., (2015), An energy management strategy for hybrid electric bus based on reinforcement learning, *IEEE Control and Decision Conference* pp. 4973-4977.
- [121] Simmons, K., Guezennec, Y., and Onori, S. (2014), Modeling and energy management control design for a fuel cell hybrid passenger bus, *Journal of Power Sources*, Vol. 246, pp. 736-746.
- [122] X. Hu, H. E. Perez, and S. J. Moura. (2015), Battery charge control with an electro-thermal-aging coupling, *ASME 2015 Dynamic Systems and Control Conference*. American Society of Mechanical Engineers, 2015.
- [123] Graham, L., Christenson, M., & Karman, D., (2006), Light duty hybrid vehicles-influence of driving cycle and operating temperature on fuel economy and ghg emissions, *IEEE Climate Change Technology*, pp. 1-6.
- [124] Wang, X., and Liang, Q., (2015), Energy Management Strategy for Plug-In Hybrid Electric Vehicles via Bidirectional Vehicle-to-Grid, *IEEE Systems Journal*.
- [125] Colin, G., Chamallard, Y., Charlet, A., and Nelson-Gruel, D., (2014), Towards a friendly energy management strategy for hybrid electric vehicles with respect to pollution, battery and drivability, *Energies*, Vol. 7, no. 9, pp. 6013 – 6030.
- [126] Patil, R. M., Kelly, J. C., Filipi, Z., and Fathy, H. K. (2013), A framework for the integrated optimization of charging and power management in

plug-in hybrid electric vehicles, *IEEE Transactions on Vehicular Technology*, Vol. 62, No. 6, pp. 2402-2412.

- [127] Alam, A., Martensson, J., and Johansson, K. H. (2015), Experimental evaluation of decentralized cooperative cruise control for heavy-duty vehicle platooning, *Control Engineering Practice*, Vol. 38, pp. 11-25.
- [128] Alam, A., Besselink, B., Turri, V., Mårtensson, J., and Johansson, K. H., (2015), Heavy-duty vehicle platooning towards sustainable freight transportation, *IEEE Control Systems Magazine*, Vol. 35, No. 6, pp. 34-56.
- [129] Jia, D., Lu, K., Wang, J., Zhang, X., and Shen, X., (2016), A Survey on platoon-based vehicular cyber-physical systems, *IEEE Communications surveys and tutorials*, Vol. 18, No. 1, pp. 263-284.
- [130] HomChaudhuri, B., Lin, R., and Pisu, P., (2016), Hierarchical control strategies for energy management of connected hybrid electric vehicles in urban roads, *Transportation Research Part C: Emerging Technologies*, Vol. 62, pp. 70-86.
- [131] Rios-Torres, J., Malikopoulos, A., and Pisu, P., (2015), Online Optimal Control of Connected Vehicles for Efficient Traffic Flow at Merging Roads, *IEEE 18th International Conference on Intelligent Transportation Systems*, pp. 2432-2437.
- [132] Luo, Y., Xiang, Y., Cao, K., and Li, K., (2015), A dynamic automated lane change maneuver based on vehicle-to-vehicle communication, *Transportation Research Part C: Emerging Technologies*, Vol. 62, pp. 87-102.
- [133] Morales Medina, A. I., van de Wouw, N., and Nijmeijer, H., (2015), Automation of a T-intersection using virtual platoons of cooperative autonomous vehicles, *IEEE 18th International Conference on Intelligent Transportation Systems*, pp. 1696-1701.
- [134] Golestan, K., Soua, R., Karray, F., and Kamel, M. S., (2016), Situation awareness within the context of connected cars: A comprehensive review and recent trends, *Information Fusion*, Vol. 29, pp. 68-83.



Clara Marina Martinez is a PhD student at Advanced Vehicle Engineering Centre, Cranfield University, UK. She obtained the MSc degree in automotive mechatronics from Cranfield University in 2014. Her current research focuses on intelligent control for electrified vehicles, driving style recognition, future speed prediction, and machine learning.

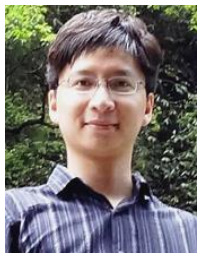

Xiaosong Hu (SM'16) received the Ph.D. degree in Automotive Engineering from Beijing Institute of Technology, China, in 2012.

He did scientific research and completed the Ph.D. dissertation in Automotive Research Center at the University of Michigan, Ann Arbor, USA, between 2010 and 2012. He is currently a professor at the State Key Laboratory of Mechanical Transmissions and at the Department of Automotive Engineering, Chongqing University, Chongqing, China. He was a postdoctoral researcher at the Department of Civil and Environmental Engineering, University of California, Berkeley, USA, between 2014 and 2015, as well as at the Swedish Hybrid Vehicle Center and the Department of Signals and Systems at Chalmers University of Technology, Gothenburg, Sweden, between 2012 and 2014. He was also a visiting postdoctoral researcher in the Institute for Dynamic systems and Control at Swiss Federal Institute of Technology (ETH), Zurich, Switzerland, in 2014. His research interests include modeling and control of alternative-energy powertrains and energy storage systems.

Dr. Hu has been a recipient of many awards/honors, including "EU Marie Currie Fellowship" in 2015, ASME DSCD Energy Systems Best Paper Award in 2015, and Beijing Best Ph.D. Dissertation Award in 2013.

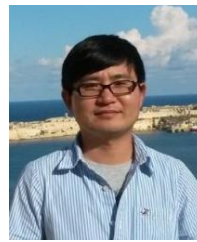

Dongpu Cao received the Ph.D. degree from Concordia University, Canada, in 2008. He is currently a Lecturer at Advanced Vehicle Engineering Centre, Cranfield University, UK. His research focuses on vehicle dynamics, control and intelligence, where he has contributed more than 90 publications and 1 US patent. He received the ASME AVTT'2010 Best Paper Award and 2012 SAE Arch T. Colwell Merit Award. Dr. Cao serves as an Associate Editor for *IEEE TRANSACTIONS ON VEHICULAR TECHNOLOGY*, *IEEE TRANSACTIONS ON INTELLIGENT TRANSPORTATION SYSTEMS* and *IEEE TRANSACTIONS ON INDUSTRIAL ELECTRONICS*. He has been a Guest Editor for *VEHICLE SYSTEM DYNAMICS*, *IEEE/ASME TRANSACTIONS ON MECHATRONICS* and *IEEE TRANSACTIONS ON HUMAN-MACHINE SYSTEMS*. He serves on the SAE International Vehicle Dynamics Standards Committee and a few ASME, SAE, IEEE technical committees.



Efstathios Velenis received his PhD degree from Georgia Institute of Technology, GA, USA in 2006. He is currently a Senior Lecturer at the Advanced Vehicle Engineering Centre at Cranfield University, UK. His research focuses on vehicle dynamics and control, optimal control for active chassis systems, traction, braking and handling control for electric/hybrid vehicles, lap-time optimisation and tire modelling. He has co-authored more than 50 publications and received the Luther Long award for best PhD dissertation in the area of Engineering Mechanics at GeorgiaTech and the Best Paper award at the 2012 International Symposium on Advanced Vehicle Control.



Dr. Bo Gao is the head of future technologies in AVL Powertrain UK Ltd. He is also in charge of the department of Electronics & Controls. Since joining AVL in 2006, Dr. Gao has been involved in various vehicle development programs and R&D projects. Prior to joining AVL, Dr. Gao was a research officer at the University of Bath, where he worked on vehicle dynamics and stability control. Dr. Gao has a PhD degree in Mechanical Engineering from the University of Bath. Dr Gao is a Chartered Engineer and a fellow of Institution of Mechanical Engineers. He holds one patent and has co-authored more than 27 technical papers.



Matthias Wellers is heading as the Managing Director the AVL Powertrain UK Ltd. for more than 10 years. Before Matthias Wellers was leading the IAV branch in UK and was working as a Senior Engineer in the Research & Technology division of Daimler in Stuttgart. Since 2014 Matthias Wellers is an elected member of the UK Automotive Council Technology Group. In the same year he founded together with the Imperial College London the Future Powertrain Conference, which has developed to a yearly event. Tianjin University China State Key Laboratory of Engines honored Matthias Wellers as a Professor Honoris Causa in 2013. Matthias Wellers is a chartered engineer and Fellow of the Institute of Mechanical Engineers and works closely together with other organizations like the UK Trade and Investment department. In 1998 he received the Ph.D. degree from the Institute of Automatic Control, RWTH Aachen. He studied Mechanical Engineering at the RWTH Aachen as well as at the Dartmouth College in USA and the Ruhr University in Bochum, Germany.

2017-06-16

Energy management in plug-in hybrid electric vehicles: recent progress and a connected vehicles perspective

Marina Martinez, Clara

IEEE

Clara Marina martinez, Dongpu Cao, Xiaosong Hu, Efstathios Velenis, Bo Gao and Matthias Wellers. Energy management in plug-in hybrid electric vehicles: recent progress and a connected vehicles perspective. IEEE Transactions on Vehicular Technology, Volume: 66, Issue: 6, June 2017, pp4534-4549

<http://dx.doi.org/10.1109/TVT.2016.2582721>

Downloaded from Cranfield Library Services E-Repository