

CRANFIELD UNIVERSITY

SYED WAKIL AHMAD

INTERMITTENT FAULT DIAGNOSIS AND HEALTH MONITORING
FOR ELECTRONIC INTERCONNECTS

THROUGH LIFE ENGINEERING SERVICES, SATM
DOCTOR OF PHILOSOPHY

THIS THESIS IS SUBMITTED TO FULFIL PhD
Academic Year: 2013 - 2015/2016

Supervisor: Dr Suresh Perinapanayagam,
March 2017

CRANFIELD UNIVERSITY

THROUGH LIFE ENGINEERING SERVICES, SCHOOL OF
AEROSPACE, TRANSPORT AND MANUFACTURING
Doctor Of Philosophy

PhD

Academic Year 2013 - 2015/2016

SYED WAKIL AHMAD

Intermittent Fault Detection and Health Monitoring for Electronic
Interconnections

Supervisor: Dr. Suresh Perinpanayagam
March 2017

This thesis is submitted in partial fulfilment of the requirements for
the degree of Doctor of Philosophy

© Cranfield University 2016. All rights reserved. No part of this
publication may be reproduced without the written permission of the
copyright owner.

ABSTRACT

Literature survey and correspondence with industrial sector shows that No-Fault-Found (NFF) is a major concern in through life engineering services, especially for defence, aerospace, and other transport industry. There are various occurrences and root causes that result in NFF events but intermittent interconnections are the most frustrating. This is because it disappears while testing, and missed out by diagnostic equipment. This thesis describes the challenging and most important area of intermittent fault detection and health monitoring that focuses towards NFF situation in electronics interconnections.

After introduction, this thesis starts with literature survey and describes financial impact on aerospace and other transport industry. It highlights NFF technologies and discuss different facts and their impact on NFF. Then It goes into experimental study that how repeatedly intermittent fault could be replicated. It describes a novel fault replicator that can generate repeatedly IFs for further experimental study on diagnosis techniques/algorithms. The novel IF replicator provide for single and multipoint intermittent connection. The experimental work focuses on mechanically induced intermittent conditions in connectors. This work illustrates a test regime that can be used to repeatedly reproduce intermittency in electronic connectors whilst subjected to vibration.

A novel ladder network algorithm is presented with an experimental setup that detects IF in interconnection. It sends a sine wave and decodes the received signal for intermittent information from interconnecting system. This novelty use basic principle of amplitude modulation and could constructed with minimum cost.

First, it describes the design and simulation to capture an intermittent fault signature using a Pspice (electronic circuit simulation software). A simulated circuit is practically verified by experimental setup. However, measurements are presented using an oscilloscope for this circuit. The results of this experiment provide an insight into the limitations of existing test equipment and requirements for future intermittent connection detection technique. Aside from scheduled maintenance, it considers the possibility for in-service intermittent detection to be built into future systems, i.e. can intermittent faults be captured without external test gear.

IFs are completely missed out by traditional monitoring and detection techniques due to non-stationary nature of signals. These are the incipient events of a precursor of permanent faults, manufacturing imperfections, or marginal/bad design in electrical interconnection. Due to random and non-predictable nature, the intermittent faults are the most frustrating, elusive, and expensive faults to detect in interconnection systems. These are short duration which could be detected by some specific techniques but these do not provide enough information to understand the root cause of it. The novel approach that, extend the previous ladder network, injects a fixed frequency sinusoidal signal to electronics interconnection system that modulates intermittent fault if persist. Intermittent faults and other channel affects are computed from received signal by demodulation and spectrum analysis. It describes technology for intermittent fault detection, and to find root cause of it. It also reports the functionally tests of computational system of the proposed methods. The results demonstrate to

detect and classify intermittent interconnection and noise variations due to intermittency.

Non-stationary/Non linear nature of intermittent faults makes troubleshoot hard with traditional equipment. Intermittent faults in electrical interconnection are short duration, which could only be detected if test equipment has test coverage both in time and frequency. The requirement of time and frequency coverage window at particular instant makes them most frustrating, and expensive faults to detect in interconnection system. One other novel advanced ladder network approach described in preceding chapter. It injects a constant value signal and spread it over a wideband using chirp signal, to electronics interconnection system for diagnosing an intermittent fault, using channel sounding techniques. This chapter describes a digital communication sounding techniques and its meth prepared for detection and classification of intermittent fault, and channel characterisation by its transfer function. This also reports the functionally tests of the proto system of the proposed methods. The results demonstrate to detect and classify intermittent interconnection and noise variations due to high temperature or corrosion. This technique could be used in-situ with low amplitude, a wideband signal over electronics interconnection. It provides the most effective tool for continuously watching the wire system for the random, unpredictable intermittent faults, the harbingers of disastrous electrical failure.

Keywords:

Transient spikes, Fault Diagnosis, No Fault Found (NFF), Signal processing Algorithms for NFF, Communication approach for IF detection.

ACKNOWLEDGEMENTS

First and foremost I am grateful to Almighty Allah who has given me a chance to get the knowledge and philosophy of science and technology.

I would like to express my sincere gratitude to my advisors Dr Suresh, Dr Mohammad, and Prof. Ian Jennions for the continuous support of my PhD study and related research, for his patience, motivation, and immense knowledge. Their guidance helped me in all the time of research and writing of papers and this thesis. I could not have imagined having a better advisors and mentors for my PhD study.

Besides my advisor, I would like to thank my thesis committee chairperson: Prof. Elisa for her insightful comments and encouragement, but also for the hard question, which canted me to widen my research from various perspectives.

My sincere thanks also goes to Chris Hockley, Andy Shaw, and Professor Raj Kumar Roy who provided me an opportunity to join their team as researcher, and who gave access to the laboratory and research facilities. Without their precious support, it would not be possible to conduct this research.

I thank my elder brother Dr Jamil Ahmad for the stimulating discussions, for intermittent signal detection using signal-processing techniques. I am also grateful to other staff who enlightening me the first glance of research.

Last but not the least, I would like to thank my family: specially my parents and to my brothers for supporting me spiritually throughout writing this thesis and my life in general.

TABLE OF CONTENTS

ABSTRACT	i
.....	iv
ACKNOWLEDGEMENTS.....	iv
LIST OF FIGURES.....	xii
LIST OF TABLES	xv
DEFINATIONS	xvi
LIST OF EQUATIONS.....	xix
LIST OF ABBREVIATIONS	1
1 INTRODUCTION.....	1
1.1 Motivation	1
1.1.1 Why intermittent fault detection?	2
1.1.2 Why tradition equipment is not suitable.....	3
1.2 Problem Statement.....	4
1.2.1 Diagnostic Issues and Impact	4
1.2.2 The Impact of NFF on Through Life Engineering Services.....	5
1.3 Aims and Objectives.....	6
1.3.1 Aims	6
1.3.2 Research Objectives.	6
1.3.3 Research questions.....	8
1.4 Contributions	8
1.4.1 Publications.....	11
1.5 Outlines on thesis.....	12
2 LITERATURE REVIEW	15
2.1 No Fault Found.....	15
2.2 Intermittent Fault causes and classification	16
2.2.1 Intermittent Faults and Degradation	18
2.2.2 Interconnections.....	20
2.2.3 Design/Timing Errors.....	23
2.2.4 Intermittent Failure of Wire Harness and Connectors	23
2.3 Intermittent Fault Diagnosis Technologies	26
2.3.1 Latching Continuity Testing.....	27
2.3.2 Reflectrometry for Intermittent Fault Diagnosis	28
2.3.3 Communication Technologies for IFs Detection.....	30
2.3.4 Analogue Neural Network based Test Methods / Models.....	34
2.3.5 Built In Self-Test (BIST).....	35
2.3.6 Intermittent Fault Diagnostics Algorithms	36
2.4 INTERMITTENT FAULT DYNAMICS AND MODEL.....	40
2.4.1 Introduction	40

2.4.2	The Nature of Intermittent Faults.....	43
2.4.3	Intermittent fault dynamics	44
2.4.4	Modelling of an Intermittent Faults	46
2.4.5	NFF Models.....	48
2.5	Summary	49
2.6	Contributions	50
3	INTERMITTENT CONNECTION FAULT GENERATOR (TEST RIG).....	51
3.1	Single Point Test Rig.....	51
3.2	Comparisons of Test Equipment and Verification of Intermittent Generator.....	54
3.2.1	N-Compass	54
3.2.2	Pico-Scope.....	59
3.2.3	Oscilloscope.....	61
3.3	Multipoint Test Rig.....	63
3.4	Contribution	66
4	LADDER NETWORK FOR INTERMITTENT FAULT DETECTION.....	67
4.1	Introduction.....	68
4.2	Ladder Network Algorithm	71
4.2.1	Resolution of Intermittent Test	75
4.2.2	The Need to Use AC Rather than DC Signals.....	76
4.3	Ladder Network PSpice Simulation	77
4.4	Experimental Verification of Ladder Network Algorithm	81
4.4.1	Experimental Setup and Circuit.....	81
4.4.2	Measurements	83
4.5	Summary	87
4.6	Contributions	91
5	COMMUNICATION TECHNOLOGIES FOR INTERMITTENT FAULT DETECTION AND FEATURE EXTRACTION	92
5.1	Introduction.....	93
5.2	Communication Approach for Intermittent Fault Detection	94
5.3	Theory and formulation	95
5.4	Novel Fault Detection Algorithm	96
5.5	Application & Case Study	98
5.6	Simulation and Validation	100
5.6.1	Experimental statistics.....	106
5.7	Summary and Contributions	107
6	DIRECT SEQUENCE SPREAD SPECTRUM FOR MULTIPOINT INTERMITTENT FAULT DETECTION	109
6.1	Introduction.....	109
6.2	Communication Sounding Approach for Intermittent Fault Detection	114
6.3	Orthogonal codes	117

6.4 Direct Sequence Spread Spectrum Sounding Technique for Multipoint Intermittent Fault Detection.....	121
6.5 Simulation.....	122
6.5.1 Simulation Results	124
6.6 Validation.....	127
6.1 Experimental statistics.....	132
6.7 Summary and contributions.....	133
7 CONCLUSIONS AND FUTURE WORK.....	135
REFERENCES	143
Appendix A Matlab Script.....	152
Appendix B Publications	169
Appendix C List of Figures and Equations	170
Appendix D Course Attended	175

LIST OF FIGURES

Figure 1.1 Fault Detection Diagnosis Rates for Aerospace Repairs (Huby & Cockram, 2010).....	5
Figure 2.1. NFF and its sub-categories	15
Figure 2.2. Major causes of intermittency in electronics devices.....	17
Figure 2.3. Degradation and its effect on different components	19
Figure 2.4. Working principle of latching continuity test.....	27
Figure 2.5. Threshold trigger circuit.....	28
Figure 2.6. Automatic test equipment vs. analogue neural network	35
Figure 2.7. Model based diagnostics diagram	38
Figure 2.8: Relation between intermittent faults and degradation.....	45
Figure 2.9 Two state Markov model	47
Figure 2.10. Aircraft Wiring Model (Alstine & Allan, 2005).....	48
Figure 2.11. NFF/Intermittent Interconnection and Detection Model	49
Figure 3.1 Shaker for Intermittent Fault Generator.....	52
Figure 3.2 Components of intermittent fault generator	53
Figure 3.3 Single Point Intermittent Fault Generator	53
Figure 3.4 Experimental Setup Diagram	55
Figure 3.5. Experimental setup to monitor intermittency using n-compass	55
Figure 3.6. N-Compass displaying intermittency in the circuit	56
Figure 3.7. Test Signal of Open Circuit.	58
Figure 3.8. Test Signal for Close circuit.....	59
Figure 3.9. Picoscope persistence mode	60
Figure 3.10. Persistence display mode	61
Figure 3.11. Experimental setup to monitor intermittency using oscilloscope ..	62
Figure 3.12. Oscilloscope to monitor intermittency.....	63
Figure 3.13 Multipoint Ethernet Intermittent Test Rig	64
Figure 3.14 Test Results for Multipoint Intermittent Generator	65
Figure 4.1. Intermittent Fault Detestability (Bryan, et al., 2008).....	69

Figure 4.2 Ladder Network IF Detection Block Diagram	72
Figure 4.3. State Representation of Intermittent Fault Detection System.....	73
Figure 4.4. Intermittent Fault Detection Algorithm	74
Figure 4.5. Intermittent Fault Detection Circuit Schematics.....	77
Figure 4.6. Input / Output Wave Form of Intermittent Fault Detection Circuit – Profile 1	78
Figure 4.7. Frequency Domain Plot of Input (dotted)/Output(solid) of Profile 1	79
Figure 4.8 simulation of profile 2	80
Figure 4.9. FFT Plot of Input Signal of Profile 2.....	80
Figure 4.10. FFT Plot of Output Signals of Profile 2	81
Figure 4.11. Ethernet Male and Female Socket with Cable Connection as an Intermittent Test Rig	82
Figure 4.12. Experimental Setup for Intermittent Fault Detection	82
Figure 4.13. Test Signal of Open Circuit	84
Figure 4.14 Test Signal for Close circuit.....	84
Figure 4.15. Intermittent Fault Detection Measurements - Profile 1.	85
Figure 4.16. Intermittent Fault Detection Measurements, Profile 2.....	85
Figure 4.17. Output Profile 2.	85
Figure 4.18. Output Profile 1	86
Figure 5.1. Block Diagram of IF detection Algorithm	96
5.2 Intermittent Fault Detection Algorithm	98
Figure 5.3. Ethernet Male and Female Socket with Cable Connection as an Intermittent Test Rig	99
Figure 5.4 Experimental Setup for Intermittent Fault Detection	99
5.5 Input sine wave to unit under test.....	101
Figure 5.6 Received noisy signal with IF information.	101
Figure 5.7 AM Demodulated Signal.....	102
Figure 5.8 Frequency Demodulated Signal with 20 Hz Shaking Connector ...	103
Figure 5.9 Phase Demodulated Signal with shaking 20 Hz External Vibration to a connector.....	104
Figure 5.10. Spectrum of Intermittent signal.....	104

Figure 6.1. Channel Impulse Response	116
Figure 6.2. PN Code Generation	118
Figure 6.3. Typical DS-SS Communication System	119
Figure 6.4. Block Diagram of Multi Node Intermittent Fault Detection using Channel Sounding	122
Figure 6.5. Two point Intermittent Fault Detection.....	124
Figure 6.6. Scope 5 Shows Transmitter 1 Output before Channel	125
Figure 6.7. Scope 1 Shows Channel Intermittent Fault	125
Figure 6.8. Scope 2. Shows Channel Intermittent Fault	126
Figure 6.9. Scope 3. Shows Poor De-spreading due to wrong Orthogonal Code	126
Figure 6.10. Scope 4 Shows perfectly synchronised PN code.	127
Figure 6.11 Experimental Setup	128
Figure 6.12. Experimental setup Block Diagram	129
Figure 6.13. Scope 1 with same PN code De-spreading.....	130
Figure 6.14. Scope 2 with same PN code De-spreading.....	131
Figure 6.15. Scope 3 with Different PN code De-Spreading	131
Figure 6.16. Scope 4 Node 2 with Same PN Code De-Spreading	132

LIST OF TABLES

Table 4-1 Ladder Network Comparison with N-Compass	87
Table 5-1 Ladder Network Comparison.....	106
Table 6-1 Advance Ladder Network statistics	133

DEFINATIONS

Intermittent Fault

1) An intermittent fault is the malfunction of a device or system that occurs at intervals, usually irregular (S. Khan, 2012).

2) Any fault in an electrical circuit that appears and then disappears over time. An example is dry arc or wet arc due to vibration and moisture (Furse, 2012).

Hard Fault:

Hard faults, also called permanent faults, are defined as permanent deviations from nominal operation, for electrical continuity these are open / short circuits and there is a large impedance change i.e. zero for short circuit and infinity for open circuit (Furse, 2012).

Soft Fault

Soft faults are defined as small deviation from nominal operating values of electric components i.e. small impedance changes due to corrosion, moisture and material aging (Furse, 2012).

Harsh Environments:

Harsh environment is defined as a setting in which survival is difficult or impossible (Anon., n.d.). The harsh environments for electronic circuits are moisture, temperature, and vibrations but there is also great impact of electro-

magnetic interference (EMI), and cosmic rays. Dust and other contaminations can also cause deviations. (J.Gracia-Moran, 2010).

No Fault Found (NFF)

- Subsequent test does not relocate the same symptom.
- Inspection reveals no existing condition that is known to correlate with the reported symptom. (S. Khan, 2012)

Fault

Fault is defined as an abnormal condition or defect at the component, equipment, or sub-system level which may lead to a failure.

Failure

A failure is the state or condition of not meeting a desirable or intended objective, and may be viewed as the opposite of success.

Reliability

Reliability is the ability of a system or component to function under stated conditions for a specified period of time (IEEE, 2005).

Safety

Safety is freedom from conditions that can cause death, injury, occupational illness, or damage to or loss of equipment or property, or damage to the environment.

LIST OF EQUATIONS

$V_n = Z_2 A \sin(2\pi f t) (Z_1 + Z_2) \quad (1)$	72
$y_t = h t, \tau * x t \quad (2)$	116
$Y_f = H_f \cdot X_f \quad (3)$	116
$H_f = Y_f / X_f \quad (4)$	116
$X(z) = \sum_{n=0}^{\infty} x(n) z^{-n} \quad (5)$	116
$H(z) = Y(z) X(z) = y_0 + y_1 z^{-1} + \dots + y_{n-1} z^{-(n-1)} + y_n z^{-n} - n x_0 + x_1 z^{-1} + \dots + x_{n-1} z^{-(n-1)} + x_n z^{-n} \quad (6)$	116
$H(2) = 111 - 1 \quad (7)$	119
$H^2 N = H N H N H N - H N \quad (8)$	120
$H^2 N = H N H N H N - H N \quad (9)$	120
$H N H N T_0 = N I N \quad (10)$	120

LIST OF ABBREVIATIONS

IT	Information Technology
NFF	No Fault Found
IF	Intermittent Fault
AM	Amplitude Modulation
FM	Frequency Modulation
PM	Phase Modulation
FFT	Fast Fourier Transforms
BIST	Built In Self-Test
DTC	Doctoral Training Centre
DSSS	Direct Sequence Spread Spectrum
AWGN	Additive White Gaussian Noise
POV	Point Of View

1 INTRODUCTION

Due to increasing demand in high level of sophistication of digital electronics circuits and automation, there is an increasing trend in the complexity. With increased complexity, the probability of occurrence of faults is also increased. Faults can occur in the electronic interconnections, components, sensors or actuators, for example, short / open circuiting or overheating of electrical components, drifting of sensors etc. Faults can cause the process to operate far away from the optimal operating points, hence, can reduce the efficiency, and could be safety critical for aerospace and other transport industry. It is more frustrating when fault is intermittent and it could not be present at the time of test. It will be tagged as No Fault Found.

The main objective of this project is to reduce NFF by improving diagnostic capabilities of intermittent fault detection through the development of novel algorithms and techniques for electronics interconnection systems.

This chapter gives a brief introduction of thesis. It starts with motivations and problem statement then introduces the research topic of NFF project. Aims and objectives are described in subsequent section. Then it moves to contributions and publications. Last section outlines the thesis briefly.

1.1 Motivation

Research topic of dissertation is “An intermittent fault diagnosis and health monitoring for electronics interconnection systems”.

The motivations of carrying out this study can be elucidated by the following three questions: (1) Why intermittent fault detection? (2) Why tradition equipment is not suitable and (3) What is impact of NFF on through life engineering services?

1.1.1 Why intermittent fault detection?

Most devices and systems contain embedded electronics modules for monitoring, control, and to enhance the functionality of cars, trains, ships and aeroplanes. The shrinking size and complexity of electronic circuits, with added redundancies, has led to difficulties in the maintenance of these modules. This becomes a challenge when faults are intermittent in nature.

Intermittent faults are a growing problem in electronics equipment (especially for aircraft and other vehicle industry) due to thermal, vibration, moisture and other stresses.

Variety of intermittent fault causes:

- Loose or corroded wire wrap
- Cracked solder joint
- Corroded connector contact
- Loose crimp connection
- Hairline crack in a printed circuit.
- Broken wire
- Unsoldered joint

Repairing an intermittent fault may not be difficult but challenging to troubleshoot and it increases the maintenance cost of the product. Further to the literature study, correspondence with industrial partners showed that wire harnesses and connectors are main causes of NFF or intermittent fault. This research will focus to electronic interconnection systems that are more prone to intermittent short / open circuit and that is one of major NFF contributor.

1.1.2 Why tradition equipment is not suitable

Most diagnostic techniques and algorithms are for linear time in-variant (LTI) systems. Traditional equipment like oscilloscope, digital multi-meter and spectrum analyser are LTI systems. Due to non-stationary nature of Intermittent fault signal does not allow to use LTI systems unless very high rate sampling algorithms are used. Even very high rate sampling equipment like oscilloscope, digital multi-meter, and spectrum analyzer are not suitable for IF detection due to lack of latching capability. As intermittent fault is not present all the time and could be for very short duration as few nanoseconds.

Often the solution to problem is to employ maintenance tools which are specially designed to detect them. There is a need to monitor all electrical paths with the capability to capture very short duration discontinuities. This project focuses on intermittent faults, especially on the wire harnesses and connectors. It will focus on mitigation of NFF through IF detection and feature extraction for root cause analysis. This could also help to understand most frustrating fault that is not present all the times.

The development of intermittent fault diagnostics is also of paramount importance in solving the phenomena known as No Fault Found (NFF), and the development of such a system would provide diagnostic information which will be used to reduce NFF through,

- A) Improve test capabilities
- B) Enhance maintenance troubleshooting
- C) Reduced maintenance cost

1.2 Problem Statement

Maintenance effectiveness and efficiency should to be 100 % if service and availability are to be delivered to customer's satisfaction. However, the occurrence of faults where the cause cannot be determined, usually described as No Fault Found (NFF), cannot be maintained effectively with satisfaction and it can often be a huge and disruptive pressure on the successful delivery of support to the customer

This section describes the NFF problem and their impact on the through life engineering services. It is used to centre and focus the problem, and validate it by giving examples and literature survey.

1.2.1 Diagnostic Issues and Impact

Although the costs are difficult to demonstrate but there are some information available on diagnostic success, particularly with respect to avionics. Based on some research done by Copernicus Technology Ltd (Huby & Cockram, 2010). The diagnostic rate for avionics is divided into two categories diagnostic success, and diagnostic failure resulting in high volume replacement due to diagnostic failure of the functional tests.

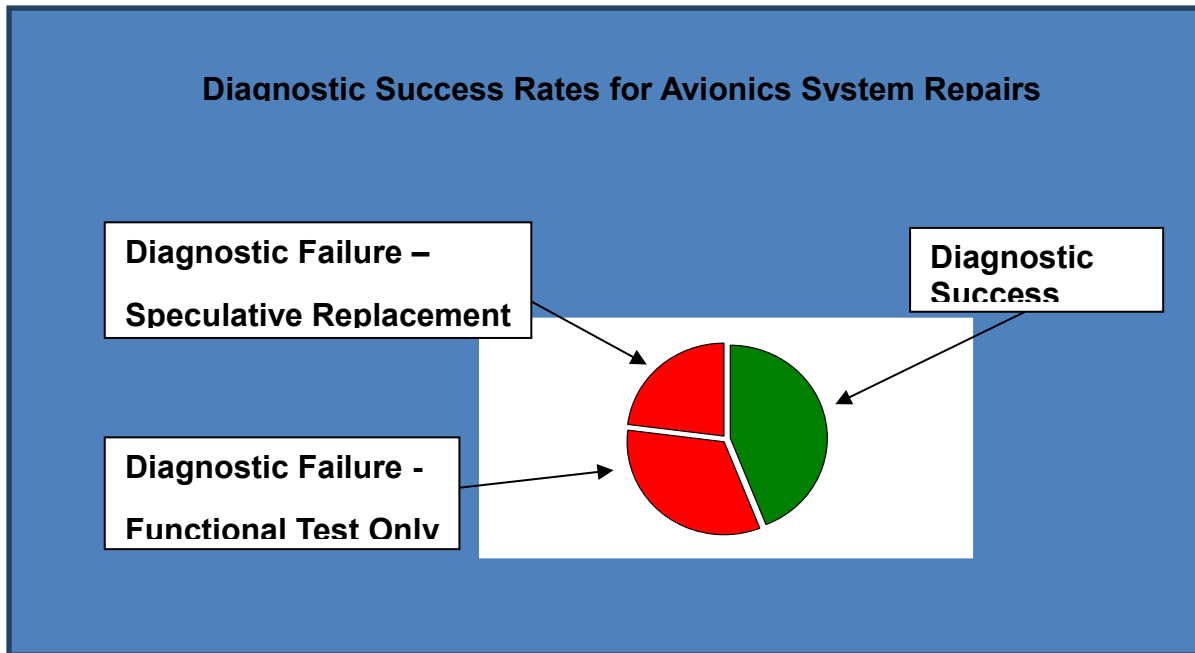

Figure 1.1 Fault Detection Diagnosis Rates for Aerospace Repairs (Huby & Cockram, 2010).

Figure 1.1 shows that considering all faults, both hard and intermittent faults, that diagnostic success is very low in avionics, perhaps only 40%. Diagnostic Failures is more than 50%. The 'Functional Test Only' is the case where technician cannot positively identify the fault, but it establishes that there isn't a fault by doing this test, the equipment declared serviceable again.

1.2.2 The Impact of NFF on Through Life Engineering Services

NFF has financial impact on all industries but transport and aerospace suffer more than others (Söderholm, 2007). The American Trans Air (ATA) member airlines lose \$100 million annually on NFF and it also cause thousands of flight delays and cancellations (Beniaminy I., 2002). This can be illustrated by considering a theoretical scenario of avionic equipment that fails every 300 hours fitted to a fleet of aircraft. The NFF rate is 50%. The fleet flies 30,000 hours per year and cost of returns and replacements is £10,000. Fault rate is $30000/300=100$ returns per year. As the NFF is 50% so the occurrence of NFF is 50 per year. So the cost of NFF per year is £500,000.

This does not include the cost of aircraft troubleshooting and recovery or operational delay costs. The included cost per fleet will become millions of pounds per year (Murray, 2013).

Intermittent faults can cause the process to operate far away from the optimal operating points and hence, can reduce the efficiency of the process, quality of the product and if grown large enough, may result in complete failure of the process which requires additional costs for maintenance. Vedam and Venkatasubramanian (Venkatasubramanian & Vedam, 1999) claim that only in US petrochemical industry, 20 billion dollars per year is lost due to poor abnormal situation management.

1.3 Aims and Objectives

1.3.1 Aims

In the through life engineering services, No Fault Found (NFF) is a frustrating scenario, the aim of this research is to overcome NFF by developing fault diagnostic / health monitoring algorithms.

The main aim of this research is to overcome No Fault Found (NFF) scenario by developing fault diagnostic / health monitoring algorithms.

1.3.2 Research Objectives.

The above aim will be accomplished by fulfilling the following research objectives:

1. To narrow down major NFF cause conduct a literature survey and industrial correspondence.

2. To develop further investigation of the selected NFF category by reproducing it in a laboratory environments. This will also make test bench.
3. To make a test rig that can further be used to investigate fault diagnostic algorithms.
4. Develop suitable algorithm/ technique that can efficiently detect NFF faults.
5. To verify the develop algorithm by experimental setup using developed test rig.
6. Identify if any improvements or alterations are required to facilitate a high service quality.

No.	Objectives	Publication
1	To narrow down major NFF cause conduct a literature survey and industrial correspondence.	Conference *1
2	To develop further investigation of the selected NFF category by reproducing it in a laboratory environments.	Conference *2
3	To make a test rig that can further be used to investigate fault diagnostic algorithms.	Journal *4
4	Develop suitable algorithm/ technique that can efficiently detect NFF faults.	Journal *3,*4
5	To verify the develop algorithm by experimental setup using developed test rig.	Journal *3,*4
6	Improvements or alterations of developed algorithm/technique to enhance the service quality.	Journal *3,*4

*1. *Study on Intermittent Faults and Electrical Continuity*. Wakil, S Ahmad. s.l. : Elsevier, 2014. 3rd Through Life Engineering Services. pp. 71-75.

*2. *Intermittent fault finding strategies*. Wakil, Syed Ahmad. 2013. CIRP.

*3. *A Carrier Signal Approach for Intermittent Fault Detection and Health Monitoring for Electronics Interconnections System*. Wakil, Syed Ahmad. 12, 2015, IJACSA, Vol. 6, pp. 144-150.

*4. *A Novel Intermittent Fault Detection Algorithm and Health Monitoring for Electronic Interconnections*. Wakil Ahmad Syed. 3, 2016, IEEE TRANSACTIONS ON COMPONENTS, PACKAGING AND MANUFACTURING TECHNOLOGY, Vol. 6, pp. 400 - 406.

1.3.3 Research questions

- How to produce repeatedly intermittent fault?
- How to model intermittent fault in the circuits?
- How to detect intermittent fault in the mix (analogue / digital) circuits?

1.4 Contributions

Intermittent fault diagnosis / detection and health monitoring is a major cause of NFF phenomenon. The literature survey has been done to classify IF in electronics systems. It has been concluded from industrial partners, and literature survey that electronics interconnection system are main IF contributor. The existing IF detection technologies for electronics interconnections needs to be improved. This thesis focuses on novel IF detection techniques/algorithms. To investigate an intermittent fault detection experimentally, a novel test rigs that can repeatedly reproduce intermittent signals for single and multi-points are described in chapter 3. Single point

intermittent signal has been produced using spring hook connector while RJ45 socket is used for multipoint intermittent interconnection system. This chapter also highlighted the comparison of different fault diagnostic equipment to verify the test rigs and to give a broad picture of intermittent faults that why there is a need for this research.

There is a lack of intermittent fault models in electronics interconnection systems. A fault model is very important to analyse an intermittent fault. To understand an intermittent interconnection a novel fault model is presented with existing models in a third chapter. This fault model has been presented using Spice and a state diagram

In chapter 4 a novel ladder network intermittent fault detection algorithm is presented to overcome limitations that are present in previously published work. A physical layer is used to avoid possible false alarms. This novel algorithm detects intermittent faults in wires/wire-harnesses, interfaces, and other electrical/electronic interconnections. This could be used to monitor data cables, PCB's and connection sockets or other electronics interconnections. This approach is unique and different from previous diagnostic methods of interconnection fault detection, it sends sinusoidal signals to ladder network and health monitoring system detects an intermittent fault when it happens. This technique reduces the false alarms with adjustable resolution according to requirements.

Chapter 5 describes a novel approach of IF detecting and characterization that has been developed by the author to overcome existing problems in IF detection equipment and it also gives useful information for root cause analysis. Novelty of the proposed new technique is the fact that signs of IF are intrinsically modulated on a carrier signal, in comparison with healthy wired communication channels and interconnection systems. In healthy communication links carrier signals propagate without any changes

that affect amplitude/phase/frequency of signal but with Additive White Gaussian Noise (AWGN). The proposed technique aims to look at signature of intermittency as a modulated message on carrier, and employ demodulation techniques to explore behaviour of health of interconnections.

This requirement of fault detection at either end is very difficult to meet since many electrical/electronic networks are connected in a complicated format, often in mesh architecture. There is a neural network based bespoke equipment to detect intermittent fault for multipoint in complicated mesh architecture but it could only be used for offline testing and it doesn't give enough intermittent fault signal information for root cause analysis. In Chapter 6 a novel approach of IF detecting and characterisation has been presented by the author to overcome above mentioned issues and it is very different from traditional diagnostic methods. The new intermittent channel sounding technique of the author spread DC signal with DS-SS and send into interconnection system for IF detection and channel measurement. This could be used for multipoint of electrical/ electronic interconnection system and diagnose the health status of the wire after de-spreading to retrieve an intermittent signal at output of system. The essence of this approach is using communication sounding techniques to detect and electrical interconnection system. The transient caused by the intermittent fault in the wire would disrupt the DS-SS signal sent over interconnection from a transmitter, and thus the DS-SS signal arriving at the receiver would contain intermittent signal information. When intermittent signals are found it will extract intermittent fault information by de-spreading i.e. multiplying it with PN-code. Only same PN-code will de-spread the signal which has been used for spreading, each node will have unique PN-codes

1.4.1 Publications

1.4.1.1 Published Journals

Wakil Ahmad Syed, Suresh. P., Mohammad. S., Ian. J., 2015. A Carrier Signal Approach for Intermittent Fault Detection and Health Monitoring for Electronics Interconnections System. *IJACSA*, 6(12), pp. 144-150.

Wakil Ahmad Syed, Suresh. P., Mohammad. S., Ian. J., 2016. A Novel Intermittent Fault Detection Algorithm and Health Monitoring for Electronic Interconnections. *IEEE TRANSACTIONS ON COMPONENTS, PACKAGING AND MANUFACTURING TECHNOLOGY*, 6(3), pp. 400 - 406 .

1.4.1.2 Published Conferences

Wakil Syed, A., Suresh, P. & Ian, J., 2013. *Intermittent fault finding strategies*. Bedfordshire, ELSEVIER.

Wakil Syed, A., Suresh P., & et-al, 2014. *Study on Intermittent Faults and Electrical Continuity*. Bedfordshire, ELSEVIER.

(Complete publications can be seen in appendix B)

.

1.5 Outlines on thesis

After this introduction chapter, a literature survey chapter is induced. It starts with NFF phenomena and highlights the financial impact on through life engineering services. It highlights different categories from human factors to technical aspects. It also describes that why this research focuses on intermittent faults in electronic systems. It advances to the main causes and classification of intermittency using a diagram. It presents from literature that degradation and manufacturing are main cause of intermittency if system is designed perfectly. It describes using a diagram how degradation affects upon the performance and introduce different faults in electronics components. Then it focuses on the diagnostic technologies and algorithms that are being used for intermittent fault detection in electronic interconnection systems.

Intermittent faults are regarded as the most difficult class of faults to diagnose and are cited as one of the main root causes of No Fault Found. This chapter also describes the technical issues relating to the nature of the fault which make identifying intermittency. It also discusses some of these issues by introducing the concept of intermittent fault dynamics, modelling approaches and state-of-the-art testing and diagnostic techniques and technologies. Intermittent fault dynamics and adopted model is also presented in this chapter.

Chapter 3 describes initial experimental work and novel test rig that replicates intermittent signals for further investigation. It compares the results of traditional and specific IF detection equipment. It also includes N-compass bespoke IF detection equipment that is being used for wide range of interconnection testing in UK and US defence industry.

Novel Ladder network for intermittent fault detection has been presented in Chapter 4. It starts with introduction and highlights the research gaps with related literature. It also describes the benefits of this technique that how cleverly it reduces false alarms by using sinusoidal signals. This controls the resolution of fault and acted as a filter without a hardware circuit of it. It describes novel ladder network algorithm and simulation results in Spice. This also describes that why AC signals are better choice than using DC constant value signal for IF detection. This algorithm has been validated through an experimental work with measurements. This experimental setup and circuit with test results has been presented in last section.

A novel IF detection technique has been presented in preceding chapter 5. It started with fundamental issue of NFF and describes the drawbacks of existing techniques. It also describes fundament of classical communication and tells how it could be used in-situ for intermittency diagnosis. It highlights that intermittent signal can be extracted using communication demodulation schemes and could also be classified with respect to spectrum of intermittency and that could be linked with external vibration for root cause analysis. It describes the algorithm and experimental that validates it. This algorithm also gives IF signal's characteristics with respect to amplitude, frequency, and phase variation that could be used to understand its effects on the system performance.

For multi-point IF detection and novel DSSS ladder network is presented in chapter 6. It uses channel sounding technique to detect IF in multi nodes. It spreads a DC constant using different spreading code to different nodes and de-spread at receiving end to get IF signatures.

Conclusion and direction for future work has been described in chapter 7. It highlights some conclusions from literature survey and correspondence with partner companies. Then it describes the useful results from initial experimental study and concludes that there is need for intermittent diagnostic technologies. It advances to experimental study for IF detection using ladder network and presents a novel diagnostic technique with improved false alarms and minim hardware use. Experimental verification shows that this technique could be used to IF detection efficiently. It also describes future suggestions that how this simple ladder network could be extended to make neural network for multi points. The multi threshold, soft values are also suggested for future work, to advance this technique for degradation monitor. IT shows that how communication techniques could be used for IF detection and feature extraction. It also highlights that how this work could be extended with intermittent signal feature extraction that could be used for root cause analysis. Sounding technique with DS-SS has been described in last section with some future work suggestion.

2 LITERATURE REVIEW

2.1 No Fault Found

When a unit is tested outside a technical system, it has normally been removed due to a fault. However, in some cases the external test may not discover any fault, tagging these occurrences as a No Fault Found (NFF) (Söderholm, 2007). NFF has similar other terms like Fault Not Found (FNF), Retest Okay (RTOK), or Cannot Duplicate (CND) (S. Khan, 2012) and is caused by many factors which include organisational, technical, cultural and behavioural. Organisational factors mean the way of reporting and communication between different departments while cultural and behavioural involves the human factors and workshop culture. The technical factors involve mechanical and electrical problems. Electrical/Electronic technical issues include built-in-test, integration and intermittent faults as show in the Figure 2.1.

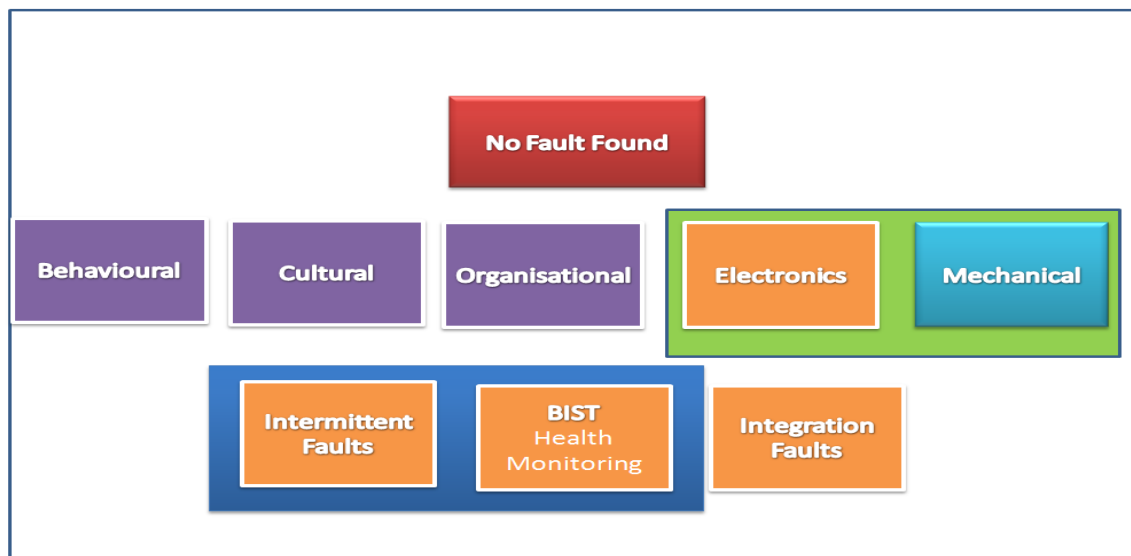

Figure 2.1. NFF and its sub-categories

One factor is marginal or bad design, also known as integration faults. Built in test is used for health monitoring in safety critical circuits but these are not suitable for IFs due to lack of ability to capture short duration non-linear faults. A 2012 survey (Huby, 2012) of 80 aerospace organisations ranked intermittent faults as the highest perceived cause of NFF, with technician experience of diagnostics and intermittent faults ranking 2nd and 3rd. The results of this survey provide a strong motivation to reduce NFF through the development of new intermittent diagnostic capabilities, encompassing both fault detection and fault isolation.

2.2 Intermittent Fault causes and classification

The key issue with all intermittent faults is that if the fault is not present at the time of testing, then it will be impossible to isolate. Even though root cause of fault may be difficult to find some common causes of intermittent faults can be analysed from past experience (Kirkland, 2011). Author has categorized past faults that has been shown in Figure 2.2.

Despite attempts to contain these early life failures using a combination of thermal and vibration screening during manufacture, the potential for intermittent faults remains. Intermittent faults, within a product can often be characterised by the repeated removal of a particular product for the same symptom, each rejection resulting in a NFF classification following workshop test.

The different types of intermittent faults causes have been portioned according to three main disciplines components, design, and connectivity as shown in Figure 2.2.

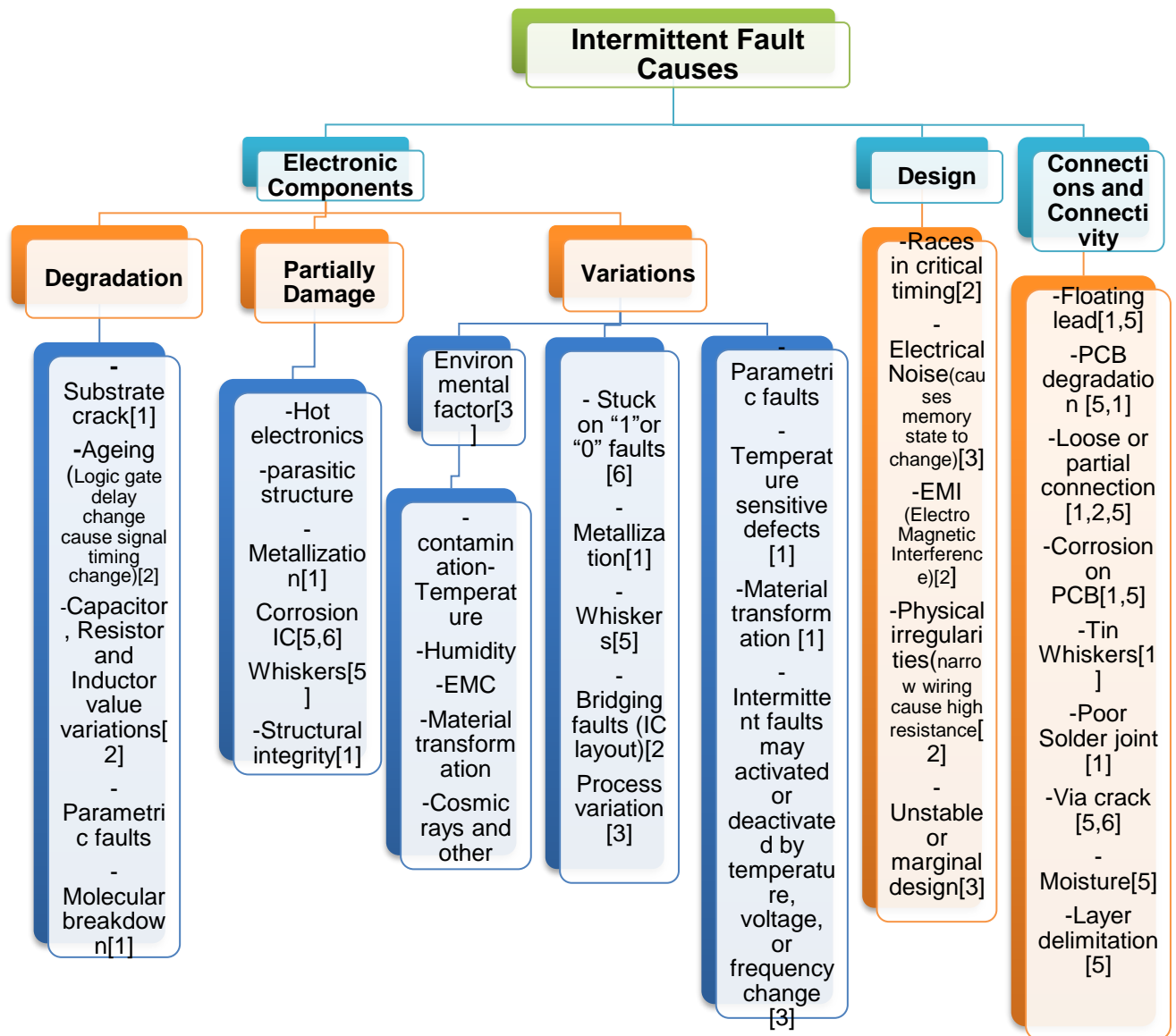

Figure 2.2. Major causes of intermittency in electronics devices

Majority of intermittent faults within electronic systems are caused by interconnections, component, and marginal design (H. Qi, 2008). The different causes of intermittent faults are illustrated in the Figures 2.2 and 2.3. Fault in any of these can manifest themselves as intermittent failure at the product level.

2.2.1 Intermittent Faults and Degradation

Intermittency in electronic components can be further sub divided into degradation, partially damage, Process variations, harsh environment, and parametric faults.

Degradation is a loss of functionality or change in the performance gradually with the passage of time. In nature this can be define as ageing process. There are many cause of electronic components degradation but harsh environment boost this effect. The change in the logic gate delays with ageing process effect the change in the signal timings and could cause intermittent problems (M.Bushnell, 2000). This also causes variation in the components value like resistor, inductor, and capacitor and cause intermittent fault (Lala, 1997). Chetan S. K. et al has presented the capacitor degradation model and impact on intermittent faults (C.S. Kulkarni, 2012). It has been described that most intermittent faults are related to gradual degradation of components or systems (A. Correcher, 2010). H. Lee et al have described the graceful degradation for digital system memory and temporary errors or intermittent faults (H.Lee, 2007).

A considerable body of knowledge exists to monitor the degradation of mechanical and structural systems due to vibration signature and variations in acoustic level (E P Carden, 2004). Degradation in electronics is much more difficult to detect and analyze then mechanical systems due to complex architecture of electronic devices, the interdependency of component

functionality, and lack of monitoring sensors due to the miniaturization of most electronic devices and products (S Kumar, 2012).

Degradation of electronic components in circuits is a major cause of intermittent fault. Figure 2.3 show the degradation on the electrical/electronic connections and components. It causes to change the impedance of circuits and it also causes parametric faults in passive components. The degradation in semi-conductors effect the bias current and changes the threshold levels for cut-off, linear and saturation region.

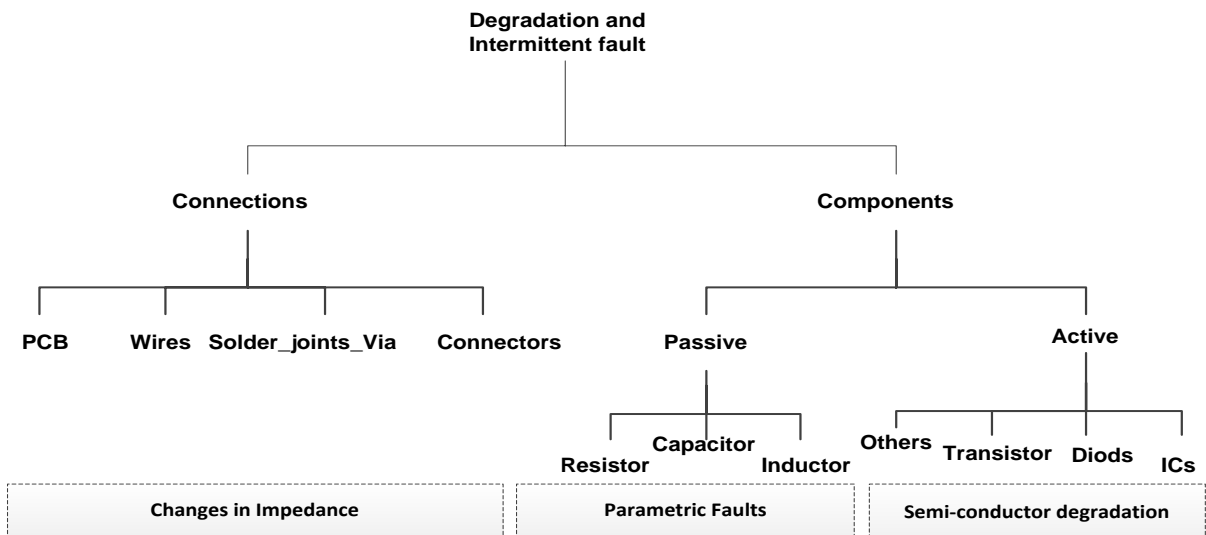

Figure 2.3. Degradation and its effect on different components

Partially damage sub system or component in the complex system can also cause intermittency. This might be due to reduction of number of bits in digital electronics.

Process variation or imperfections can also cause intermittent behaviour of semiconductor devices. Some time it is possible to pass all functional testing during manufacturing but still cause intermittent faults (C.Constantinescu, 2008).

2.2.2 Interconnections

In Electronics systems, loose connections probably cover most of the faults that have been published as NFF (J.Jones, 2001) (J.K.Line, 2008) . The quality of the solder joints, made during original manufacture will determine the reliability of the product; failure of any one joint within the thousands present in an electronic circuit can cause failure. Furthermore, the trend towards a high integration of electronic devices within today's electronic products is made possible by the development of smaller devices. As electronic device sizes reduce, so too does the pitch between component connections. This makes accuracy of the soldering process far more critical and its management key to the product reliability.

The most common cause of failure in electronic products is the 'dry' solder joint. A dry joint is one in which the solder has not formed a satisfactory joint in terms of electrical connectivity and strength. As there are many variables that may affect the success of the soldering process, an inspection will normally be carried out to ensure all joints are of a high integrity. Where particular joints do not pass the inspection stage, a manual re-flow process may be used.

As dry joints are a very common cause of failure within electronic products, there are a number of fault-finding techniques that have been developed to aid in the isolation of the offending joint. The techniques used will often be very basic in

nature. Varying the local temperature using freezer spray or a heat gun is a very popular workshop procedure. It must be noted, however, that such diagnostic activity can also cause damage to other components and so must be well controlled.

Loose debris may find its way into the product during its manufacture stage, potentially providing a short circuit that may relocate as time goes on. Debris may also find its way into solder joints during manual rework. Where some debris is contained within a solder joint, it may short the joint to adjacent joints, device pins or the PWB. Once the system failure mode has been re-created [by stress-screening for example] the fault can be confirmed by a close visual inspection.

Solder bridges are formed when excess solder connects two nodes that were not supposed to be connected. This is usually a result of poor quality control processes and should be fairly easy to diagnose by inspection once the fault has become hard.

Solder joint ageing is a problem with all electronic units subjected to long term thermal environmental stresses. Such intermittent will eventually become hard faults. Prior to this, a close examination of all solder joints under high magnification may highlight those areas in which ageing has occurred. If solder ageing becomes a general problem with a particular product type then a scheduled inspection and rework activity at an appropriate frequency may be a more cost effective way of dealing with the problem. This will be particularly true

if failure of the product can have a significant consequence [delay, cancellation, or safety effect] at the aircraft level.

Failure of Printed Circuit Boards [PCB] in a manner that results in intermittent failure appears to be less of an issue than for the solder joints that are made on it. Today's PCBs are becoming far more complex; more devices are being fitted in the same surface area resulting in a reduced pitch between devices and more layers to facilitate connection between them.

Where an intermittent fault is reported, the act of disconnection and reconnection of a PCB or module within a system has been known to temporarily clear the fault. This will often result in a NFF classification where it should actually have been defined as a confirmed fault. The failure may be due to surface corrosion (e.g. oxidation of pins or fretting wear), bent pins, debris within the female connector, or incorrect fitment during initial manufacture. Unless issues such as these can be closed down to root cause then corrective action cannot be taken and any future designs will continue to carry the potential for intermittent connection and hence susceptibility to NFF, repeat removals.

The internal wiring within an electronic product is a potential location for intermittent failure. Poor connection (high impedance) as well as intermittent open circuit may result in anomalous behaviour at the product level. Internal wiring has developed from the original concept of lacing together wiring looms comprised regular multi-strand insulated wire. Variations on this theme have been developed with the intention of saving space and weight, easing assembly,

improving reliability, reducing cost, etc, with varying success; suffice to say that there are good and bad examples of each manifestation and each new design should be taken on merit.

2.2.3 Design/Timing Errors

Those products which rely upon a particular behaviour from an interfacing device for correct operation may be susceptible to faults that may be observed as intermittent failure. The interaction of a product, which relies upon software for its operation, with another product may periodically exhibit failure due to incompatibilities between the system interfaces. These incompatibilities may include variation in the relative timing of particular operations, where synchronisation is required for accurate system operation.

Systems that have been fully optimised to ensure a robust system interface between component parts may show not failure for many years of service. However as system interfaces are affected by wear and over a period of time, failures may become evident. As such a failure mode will be seen as a wear out issue, timing or system interface concerns may not be considered an appropriate path for investigate, resulting in the risk of root cause misclassification i.e. the failure may be classed as wear or drift of the component part rather than lack of margin in the interface during system design.

2.2.4 Intermittent Failure of Wire Harness and Connectors

Wiring and interconnect systems have become a major area of research and development from aerospace to defence equipment (B.G. Moffat, 2008). The

wirings have tremendously increased in modern vehicles because of onboard electronic /electrical devices.

Studying the impact of manufacturing and degradation defects becomes important. It is standard procedure to test them electrically. Hard failures are easy to detect and to eliminate but intermittent failures are very difficult to detect and they are likely to pass manufacturing and other schedule tests. One of the most common and critical failure in electrical systems is the intermittent disconnection (S. Hannel, 2001).

The two basic problems that can occur in wire harnesses are open and shorts circuits. Intermittent are usually caused by some mechanical change like temperature, vibration, moisture and physical stress that temporarily changes the electrical characteristics of device under test.

H.Qi et al in their research of intermittent failure in electronics product has illustrated that 80% of intermittent faults are due to loos/contaminated inter-connections.

Connectors and wire harnesses subject to harsh environments may experience vibration resulting in fretting corrosion and degradation in contact resistance over time. Connector degradation causes intermittent failure due to impedance mismatch.

Many authors have taken investigation into intermittent faults. Abbott et al. and Murrell et al. detect intermittent behaviour using counters and Hubner et-al. measure the contact resistance during intermittent fault behaviour. P.Lall et-al.

has investigated connectors for automobiles subject to vibration. F.Loete et-al has done experiment to detect the degradation in the connectors. A.E. Ginart et-al. has presented on-line methodology for detecting intermittent disconnection failures. Y.Lei with Y.Yuan and J. Zhao have used model base approach to monitor the CAN bus for intermittent connections.

Abbott et-al. (Abbott & K.Schreiber, 1981) (Abbott, March 1984) defines a contact voltage-drop of threshold between 0.2V to 0.5V as intermittent fault. Murrell et-al (S.R. Murrell, 1997) used a 10 mA constant current source with an open circuit voltage of 1V and defined the intermittency as any event exceeding a contact resistance of 10 Ω . The classical contact theory has been applied by Skinner to evaluate several possible short duration intermittent failures in open or high resistance caused by mechanical motion (Skinner, 1975 current version 2003). A. Lee has described that fretting corrosion increases the contact resistance and this cause earlier and more frequent discontinuities (A.Lee, 1987). Fretting is a major cause of contact deterioration and failure and is a main cause of intermittency or short duration discontinuities (C. Maul, 2001).

Connector's degradation causes electrical failure during or prior to vehicle operation, P.Lall et-al simulated connector's degradation in vibration test profile and used in-situ resistance spectroscopy (P.Lall & R.Lowe, 2012). Y.Lei et al have presented model base intermittent connection detection for Controller Area Network (CAN), he used maximum likelihood estimation based model for intermittent events (Y.Lei, 2013). F.Loete et al have used frequency domain reflectometry for connector's degradation monitor (F.Loete, 2012). They also

described other literature for wire harness and connector degradation. They have simulated degradation monitor with DC contact resistance and impedance spectrometry at 1MHz.

2.3 Intermittent Fault Diagnosis Technologies

The more complex electronic systems are entering the market and the ability to maintain them is becoming ever more challenging and expensive. Conventional test equipment, which require carrying out the fault investigation, are not always successful (S. Khan, 2012). This can be because the necessary levels of confidence and efficiency are inappropriate in the many industries, which are suffering NFF failures. If testability as a design characteristic were successful, perhaps NFF would not be so problematic. This is particularly evident in the case of attempting to detect and isolate intermittent faults at a test station – the ability to test for short duration intermittency at the very moment that it re-occurs using conventional methods is so remote that it will almost certainly result in a NFF. The one major issue with designing component testability is that the focus is on functionality and integrity of the system at the ATE is not tested (Syed, et al., 2013).

Many test equipment is used to detected anomalies in electrical parameters and temperature profiles. The more common ones include multi-meters that detect steady or slowly varying electrical signals. On the other hand, digital oscilloscopes are used for rapid changes based on the sampling function. Problem with an electric intermittent fault is that it occurs for only a short duration,

making it difficult to detect unless a very high sample rate is used. This goes beyond the capabilities of typical test equipment. The intermittent fault diagnostics technologies includes latching continuity testing, analogue neural network technology and time domain reflectometry.

These technologies are described in details in preceding sections.

2.3.1 Latching Continuity Testing

The latching continuity testers can typically detect continuous electrical parameters (such continuity) for open and closed circuits and power interruptions. It is essentially based on the working principle of a threshold comparator where a Schmitt trigger is used to detect the change in the voltage. The latching function uses the bi-threshold configuration. When an input voltage exceeds the first threshold, it triggers the output to a high level and 'latches' to that high state unless the input signal drops to the second threshold level (see Figure 2.4). The circuit diagram is shown in Figure 2.5.

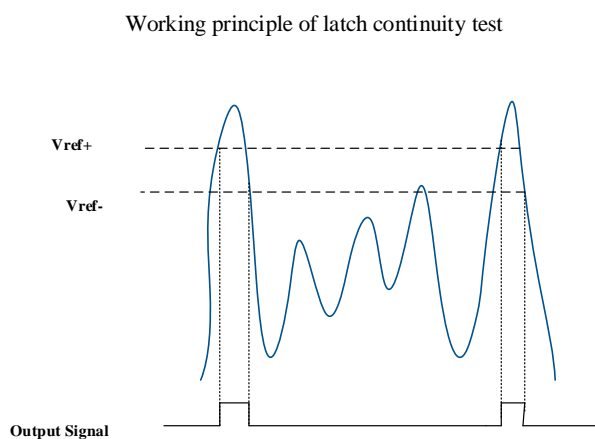

Figure 2.4. Working principle of latching continuity test

Threshold trigger circuit

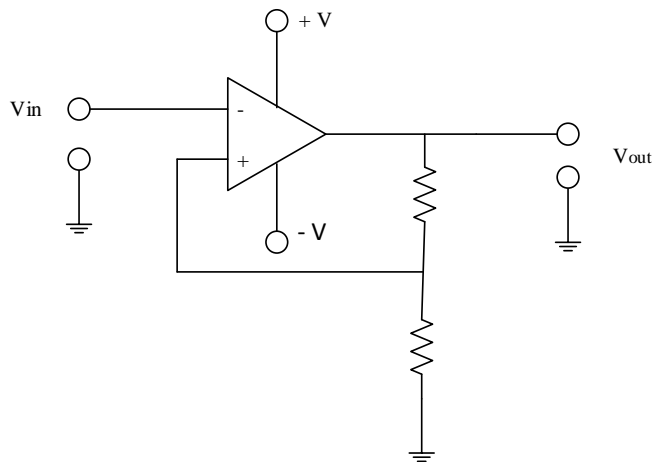

Figure 2.5. Threshold trigger circuit

Sorenson et al have used this method in capacitively coupled neural network to capture very short duration, up to nano second , intermittent fault (Sorenson, 1998).

2.3.2 Reflectometry for Intermittent Fault Diagnosis

The concept of reflectometry as a measurement technique has been well established. It has effectively been used to detect discontinuities in connections (also circuits, wires and cables) using pulses and monitor electrical reflections. Some of the most popular published material on Time Domain Reflectometry can be found in (Smith, 2005) (Md Thayoob, et al., 2010) (Jyh-Ming & Tripathi, 1992 ; current version 2002), Time Domain Spread Spectrum Reflectometry (Hill & Felstead, 1995), Standing Wave Reflectometry and Frequency Domain Reflectometry (Smith, 2005).

Time Domain Reflectometry (TDR) is an electronic instrument to diagnose the faults in the electrical conductors. It is used to test cable's wiring in aircrafts but can also be used in Printed Circuit Board. TDRs transmit a short duration pulse in circuit if there is a intermittent or other fault this will be reflected due to impedance mismatch else this will be absorbed in far end. The magnitude of reflection is known as reflection coefficient. The reflection coefficient ρ is "1" for open circuit and "-1" for short circuit. It is defined as $\rho = \frac{Z_t - Z_o}{Z_t + Z_o}$ where Z_t is the impedance of termination far end and Z_o is the impedance of transmission media (Hoekstra, 1974).

Spread Spectrum Time Domain Reflectometry (SSTDR) is a measurement technique to identify the continuity faults in the electrical / Electronic circuits (Smith, 2005). SSTDR is a time domain reflectometry which has advantage on other time domain reflectometry due to ability to use in high noise and live environments. This also can locate the faults more precisely due to high resolution. The working principle of SSTDR is to modulate the signal with Pseudo Random PN code and cross correlate the received signal with the reflected signal to check the continuity faults in the circuits. Spread Spectrum reflectometry can measure the four junctions with one sensor (Smith, 2005). It is recognised that when a Radio Frequency (RF) signal applied to electrical or electronic circuit it encounters a discontinuity due to impedance mismatch. The small portion of signal reflects back depends upon the difference of impedance. It is very hard to determine the fault location with single frequency but the broad band of frequencies are used to improve the resolution to determine the exact distance.

In frequency domain reflectometry it apply a set of stepped sine wave frequencies to the circuit and reflected signal are used for continuity fault diagnosis. The basic working principle is same as TDR but the measurement methods are different. The operation is similar to radar. In frequency domain reflectometry there is frequency, magnitude and phase that can be used for continuity test (Chung, 2006) measurements. There are three methods that are used in the FDR. The Frequency Modulated Carried Waves (FMCW), Phase Detection Frequency Domain Reflectometry (PD-FDR) and Standing Wave Reflectometry (SWR). In FMCW a very quickly varying modulated carrier applied to the system and frequency shift is calculated to localize the fault. This calculated by using the shift in frequency correspond to time delay in the time domain property. In PD-FDR it is similar to FMCW but the phase in frequency domain to derivatives in time domain property is used to calculate delay time for the localization of the open or short circuit. In SWR the magnitude of standing waves or location of null in frequency domain is used to calculate the location of the malfunction.

2.3.3 Communication Technologies for IFs Detection

An intermittent fault (IF) is an electrical spike that develops from ageing of electric interconnects, cuts, rubs, or loose contacts, and manifests itself intermittently in an unpredictable manner. If these are not detected on time or at the early stage, it would gradually lead to permanent fault and are also safety critical (Correcher, et al., 2012). This also lead to, many other problems for example delayed or

cancellation of flights, electrical arc or spark that could lead disaster that progressed from IFs.

Manufacturing imperfections, poor design and system degradations are main causes of intermittent faults (Syed, et al., 2013) Although Sheng et al are disagree that intermittent faults are precursor of permanent failure (Sheng, et al., August 2014) but S. Bryan et al says that intermittent faults are precursor of hard failure (Bryan, et al., 2008). These both statements could be true, depends upon causes of intermittency. IF due to system/component degradation are precursor of permanent faults but marginal design or manufacturing imperfection are not signs of hard failure. Irrespective of causes; IFs are random and non-reproducible incidents, and are most frustrating, elusive, and expensive faults to detect and locate in wiring / interconnection systems.

IFs are identified by visual or traditional instruments for electronic/electrical interconnects. It has also been reported that conventional test equipment, which is required to carry out the fault investigation, are not always successful. This can be due to the fact that the necessary levels of confidence and efficiency are inappropriate in the many industries which are suffering No Fault Found (NFF) failures (H. Qi, 2008). If testability as a design characteristic was successful, perhaps NFF would not be so problematic. This is particularly evident in the case of attempting to detect and isolate intermittent faults at a test station the ability to test for short duration non-stationary intermittency at the very moment that it re-occurs using conventional methods is so remote that it will almost certainly result

in a NFF. The one major issue with designing component testability is that the focus is on functionality and integrity of the system.

There are many test equipment that are used to detected anomalies in electrical interconnection systems. The more common ones include multi-meters that detect steady or invariant signals. On the other hand, digital oscilloscopes, and spectrum analyzers are used to monitor time domain and frequency domain time invariant signals. Problem with an intermittent fault is that it occurs for only a short duration and it is time variant, making it difficult to detect unless a very high sample rate it used. This goes beyond the capabilities of typical test equipment. The current state-of the-art in intermittent fault detection during maintenance testing includes latching continuity testing, analogue neural network technology and time domain reflectometry.

There are various disadvantages of these techniques: to halt operation for inspection, hard to capture or watch on oscilloscope or voltmeter as well as ineffectiveness due to many inspection points and some time being in the location frequently hard to reach or observe. These are unable to detect the fault in many cases since the duration of the fault was often short and not consistent. System would behave normally and it would find the interconnection/wire system normal or NFF status. Therefore, it is easy for the observer or instrument to miss the occurrence of intermittent fault.

Much research has been done on reflectometry wiring fault detection and that is used for high power electrical wirings and could not be used for interfaces and

lose solder joints or for other electronics circuits. The concept of reflectometry relies on transmitting electromagnetic waves across the wire and observe the reflections. These reflections depends upon the variation of impedance in the wire system as $\frac{Z_1 - Z_2}{Z_1 + Z_2}$, where Z_1 and Z_2 are impedances of two electrical mediums (Smith, 2005) Time between the incident and the reflected wave is used to locate the fault. Magnitude of reflections are used to determine if it is a potential fault or not. These techniques have drawbacks for modern electronics / electrical system that any change in the wire material (e.g., connection in circuit) reflects the incident waves resulting in incorrect fault determination. These techniques usually require high voltage pulses.

Recently, direct-sequence spread-spectrum (DS-SS) signals are used instead of high voltage signals employing digital signal processing techniques to find and locate electrical faults (Smith, 2005). Taylor and Faulkner proposed direct-sequence spread spectrum modulation on power line carrier, and outlined optimal signal processing techniques and frequency domain correlation techniques for the on-line test in high voltage line (Kim, 20-22 April 2009). Lately, slightly different use of spread spectrum was reported from the research result of on detecting live wire problems (Cynthia, et al., 2005). These techniques work on reflectometry, and it solves the need to use low voltage signal, that does not interfere with online signals and could be used in-situ, but still there is a problem of reflection occurring at all points of interconnections in the circuit. So this technique is inadequate for interconnecting system, where there are many interfaces and connectors. This is also not suitable to use for electronic circuits

i.e. for PCBs, solder joints, interfaces, and similar interconnecting systems. Otherwise, the injected signal would be reflected from both ends and result in a combined, distorted, and reflected false signal due to impedance mismatch.

2.3.4 Analogue Neural Network based Test Methods / Models

Some early discussions with academics have suggested to the fact that intermittent connections which are caused by wear and stress could perhaps progressively get worse over time. Traditional testing methods (that measure one point at a time using scanning methods) may not always be effective in detecting these intermittent connection problems during incipient stages. A sensitive analyser was introduced by Universal Synaptic to simultaneously monitor test lines for voltage variation, and seems to have become an attractive tool for detection of the intermittency. Conducting the intermittency test simultaneously using an analogue neural-network process provides an increase in probability of this substantial increase in the probability of detection, combined with the reduction in the time taken to complete the test (because the testing is performed for multiple points simultaneously, rather than testing one line at a time) mean that exploiting analogue neural-network equipment to detect and eradicate intermittent faults in electrical and electronic aerospace components, are potentially of the most effective test methodology, to use the principle of which is illustrated in Figure 2.6. The analyser tests entire test points in a simultaneous and continuous manner. This indicates that the overall test coverage is several orders of magnitude more effective than conventional test technologies at detecting intermittency. It has been proven on the F-16 AN/APG-68 Radar system

Modular Low Power Radio Frequency (MLPRF) unit where \$36 million dollars' worth of assets, previously deemed "un-repairable" have been returned as serviceable.

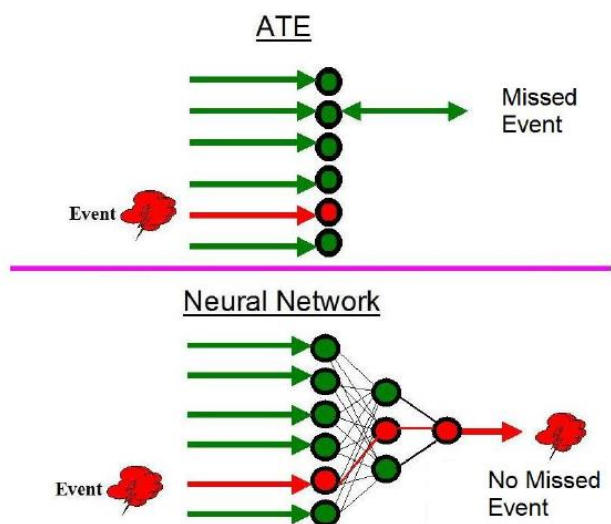

Figure 2.6. Automatic test equipment vs. analogue neural network

The equipment has also shown considerable promise in the UK RAF on the Tornado and Sentinel aircraft fleets.

2.3.5 Built In Self-Test (BIST)

The design for testability is a critical issue and it compromises between circuit size/power and reliability. BIST are not only useful to online or offline testing the system on chip (SoC) but also very helpful to boost the manufacturing process as more than sixty percent of full product development cycle time is in verification. The conventional techniques for off-line testing make use of algorithms to find a set of test vectors to detect the modelled faults in the circuits. These test vectors

can either be applied externally or stored in the chip, if stored in the chip then it is called offline BIST (R & et, 1988) . James et al. From Ridgetop Group inc. has presented BIST algorithm for intermittent health monitoring to the solder ball joint in Field Programmable Gate Array (FPGA). The experimental setup and Highly Accelerated Life Test (HALT) algorithm details can be found in the James paper (J.P. & et, 2010).

John et al. has worked on built in test (BIT) for an intermittent health monitoring intelligent techniques which includes, adaptive BIT, temporal monitoring BIT and opportunistic diagnostic BIT. The details of these algorithms with different configurations of neural network and Markova state model can be found in (J. & et, 1989).

2.3.6 Intermittent Fault Diagnostics Algorithms

2.3.6.1 Diagnostic Fault Tree

Fault-tree analysis can be a useful analytic tool for verifying the reliability and safety of a complex system. They are traditional manual fault diagnostic approaches that use 'diagnostic decision tree maps' to troubleshoot a system by reducing the number of test points. To be able to diagnose, a system designer seeks to answer some questions, like what kind of components has been used and what is their impact on the system. Singh et al has used the fault tree method for intermittent faults diagnosis for electronic control unit (ECUs) and sensors for vehicles and built a data-base of signals to describe the possibilities for intermittent failure. It provides a series of cascaded decision trees containing

different and independent features, when features are being used it reduces the decision tree. They develop computer software to automate this. More details on Fault tree system for diagnosis can be found in (Assaf, 2003) (Jiang Guo, 2012).

2.3.6.2 Case Based Reasoning for Intermittent Faults

Case-Based Reasoning (CBR) is a way of using past solutions to a similar new problem (Kolodner, 1993). It is the process to retrieve a prior case from the database, and attempts to determine its relevance to decide what and how the solution should be done, (al, 2003). CBR has been applied to aircraft malfunction handling and rail fault detection (al, 1993).

CBR is a traditional way to diagnose a problem in the vehicles. Sing et al has used CBR with decision trees for intermittent fault diagnosis in vehicles.

D'Eon et al has patent a case based reasoning system and method for determining a root cause of a problem case. A case database stores case data correlated to a plurality of cases. The plurality of cases includes at least one solved case and at least one trigger case. Each solved case database includes root cause data and each trigger case comprises a data link to at least one fault isolation manual process for determining a root cause. A processor determines a list of at least one potential case selected from said plurality of cases by comparing the at least one problem attribute value to the set of attribute values for each of the plurality of cases (D'Eon & al, 2007).

2.3.6.3 Model Based Diagnostics

As a subfield in the artificial intelligence, diagnosis is the development of algorithms and techniques that are able to determine the behaviour of the system (Hamscher & Klee, 1992). The main stands of research in model base, to make a general analysis engine that should capable of performing conclusions using the constraint model of a domain (Chris, 1999). Abreu R. et al and Liu J. et al have used Bayesian and Markov models (Liu & Zhang, 2011) (Abreu, et al., 2009).

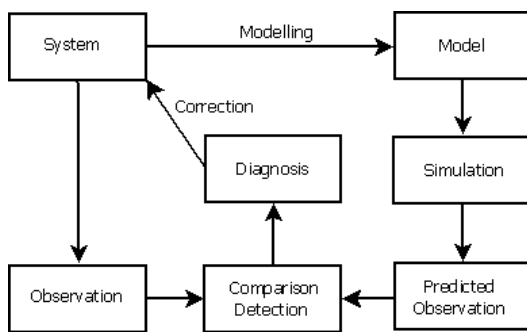

Figure 2.7. Model based diagnostics diagram

The typical example of Model-Base diagnosis has been illustrated in the Figure 2.7. Model base diagnosis for the intermittent faults includes physical equations; state equation, state observers, transfer-function, neural and fuzzy models (R.Isermann, 2004).

IF detection could be perceived as anomaly detection. A model base approach using data mining techniques for anomaly detection has been presented survey on successful anomaly detection (Agrawal, September 2015). In this paper survey of different data mining techniques have been presented, some of these

need to train the model but other do not need training and there are also hybrid techniques.

2.4 INTERMITTENT FAULT DYNAMICS AND MODEL

Intermittent faults are regarded as the most difficult class of faults to diagnose and are cited as one of the main root causes of No Fault Found. There are a variety of technical issues relating to the nature of the fault which make identifying intermittency. This chapter discusses some of these issues by introducing the concept of intermittent fault dynamics, modelling approaches, testing, diagnostic techniques, and technology models.

2.4.1 Introduction

Systems faults are usually classified as permanent, transient or intermittent fault [1]. A system experiencing a permanent fault also referred to as a 'hard fault' will exhibit a continuous deviation from its specified performance specifications. Intermittent faults can be defined as a temporary malfunction of a device. These malfunctions last for a finite period of time, where the device will then recover its normal functionality. Intermittent faults are repetitive and occur at periodic and often irregular intervals, separated by a fault 'reset' event where normal behaviour resumes. Transient faults, at first glance often appear to be in the same class as intermittent faults, that is their symptoms also only last for a finite time. There are however some fundamental differences. The root cause of an intermittent fault as the measurable symptom of the degradation of some physical aspect of the system. As this degradation increases, the rate and severity of the intermittent symptoms will also increase in severity until eventually the degradation has resulted in the intermittent fault becoming a permanent system fault. Transient

faults however, do not necessarily repeat themselves as the symptom of a one-off, single event interaction. The fundamental difference is that transient faults therefore are not necessarily considered as symptoms of degradation or manufacturing imperfections.

Understanding the fundamental nature of intermittent faults would allow for the design of reliable and robust diagnostic techniques and technologies, for both in-situ and maintenance test-bench applications. The deployment of intermittent fault diagnostics is also of paramount importance in solving the phenomena known as No Fault Found (NFF). Traditionally, any product removal that exhibits no fault (during subsequent acceptance testing) can be categorised as NFF. However, for a number of these events, further investigation could conclude that the reason for the product removal was caused by an external influence not present during testing of the removed system, these may include environmental effects, integration with other systems, damaged wiring or loose/damaged connections. However, it may be that the removed system is inherently faulty but the test equipment is inadequate to identify the nature of the fault, this is usually because the fault was not perceived during the systems design, or the fault has not been experienced before so that the symptoms are not recognised; or the fault is intermittent and does not manifest within the test window.

A 2012 survey of 80 aerospace organisations [2] ranked intermittent faults as the highest perceived cause of NFF, with technician experience of diagnostics and intermittent faults ranking 2nd and 3rd. The results of this survey provide a strong

motivation to reduce NFF through the development of new intermittent diagnostic capabilities, encompassing both fault detection and fault isolation.

2.4.2 The Nature of Intermittent Faults

Often in the literature the words transient fault and intermittent fault are used interchangeably as they are often regarded as having the same attributes. This is however argued by the author as not the true case and they should be treated as unique fault cases.

What is key is that a transient fault is the result of some unobserved behavioural mode resulting from an interaction with an environment. For example, a temporary spike in a proximity sensor due to a magnetic coupling between the sensor and a structure; a reset event in an avionics system due to solar neutrino radiation or a sudden temporary change in resistance in a circuit due to temperature fluctuations. All of these events are recoverable and do not represent a physical degradation of the system. Intermittent faults however do represent symptoms of physical degradation and will reoccur after some time with a similar fault signature. A transient fault may reoccur but the exact circumstances will not be reproduced and will have an identifiably different signature. This leads onto a set of specified rules which are proposed in resistance in a circuit due to temperature fluctuations. All of these events are recoverable and do not represent a physical degradation of the system. Intermittent faults however do represent symptoms of physical degradation and will reoccur after some time t with a similar fault signature. A transient fault may reoccur but the exact circumstances will not be reproduced and will have an identifiably different signature. This leads onto a set of specified rules which are proposed in this current research to separate the two fault types.

Rule 1: Intermittent fault behavior is the switching of a constituents physical behavior between (at least) two conditions that correspond to elementary behavior modes

Rule 2: The fault event f_i must have occurred at least twice with separated by a fault reset event r_i .

Rule 3: If the last event to occur is r_i the system is operating within the 'normal' behavioural mode, else if the last event to occur was f_i the system is operating within the 'faulty' mode (intermittent and present)

The importance of being able to distinguish between these two classes of faults is that they often require two different maintenance activities. Transient faults will not necessary require a system removal/replacement/repair whereas intermittent faults being the symptom of degradation will require a physical replacement/repair.

2.4.3 Intermittent fault dynamics

What is assumed about intermittent faults here is that they are a symptom or manifestation of the degradation of some physical property of a system component. As it is a well-established fact that degradation will increase over time until a point where that component completely fails 'hard-fault' it stands to reason that the nature of the intermittent fault signal will also change with this degradation. For example, consider Figure (2), which represents a theoretical curve of degradation. Within a region below the threshold of Point A there will be no symptoms of faults and the system will continue operating uninterrupted. Above the threshold Point B the system will have degraded to such an extent that a permanent "hard" fault is continuously observed. Between Points A and there is a region where IF occurs. At the early

stages of degradation the intermittency is likely to have a small amplitude, short duration and low frequency; whilst in the later stages of degradation the signal will have large amplitude, long duration, high frequency as shown in Figure 2.8. This concept does allude to the idea that if IFs start out as a mere ‘nuisance’ and eventually result in ‘hard-faults’ This introduce a concept that intermittent faults have dynamics

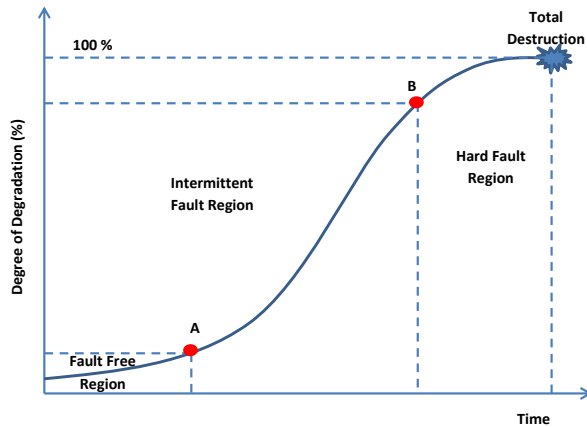

Figure 2.8: Relation between intermittent faults and degradation

There are a number of approaches to estimating the level of intermittency, the simplest approach being a counting of the number of times intermittency occurs within the time frame. In this model, the concept of Intermittent Fault Density is used as the measure. The density captures the faulty dynamics within the specified time and is defined as the average time the fault is active within a time window and is described by:

$$\rho(T) = \frac{\sum_{i=1}^{CNT} ((TR_i - TF_i) - T_A)}{W} \quad (1)$$

Where CNT is the number of faults within the window of length W ; $(TR_i - TF_i)$ represents the fault duration time of fault i . The density is calculated from $ti - W$ to ti and takes into account the duration of a fault that occurred before $ti - W$ and continued active inside of the window thus:

$$T_A = FT_{(k-1)} + T_{(k-1)} - (ti - W) \quad (2)$$

Through direct monitoring of the density of faults over time a pre-set threshold level can be set, to signify the maximum acceptable level.

2.4.4 Modelling of an Intermittent Faults

One of the most popular techniques for modelling intermittent faults is through the use of Markov chains/models. The concept is that if the system is intermittent then at any given time it must be in either a faulty or a non-faulty state. Many published works make use of a 2-state Markov model as shown in Figure 2.9. In this model the transition probabilities between two states are given as $P_{1,0}(t)$ and $P_{0,1}(t)$ and the probability that the system remains in its current state is $P_{1,1}(t) = 1 - P_{1,0}(t)$ and $P_{0,0}(t) = 1 - P_{0,1}(t)$. In this modeling process there is a basis upon the probabilities of transitions between the FA (fault present and active) and FN (fault is present but inactive). It is possible to identify four types of data which are of significant importance when considering intermittent faults. These are (1) the set of windows where the fault is considered to be active ($FA = [FA_1, FA_2, \dots, FA_n]$); (2) the set of the windows where the fault is present but not active ($FN = [FN_1, FN_2, \dots, FN_n]$); (3) the indices for when a transition occurs between state FN and FA ($TF = [TF_1, TF_2, \dots, TF_n]$); and (4) the set of times when the system recovers from being in the FA state ($TR = [TR_1, TR_2, \dots, TR_n]$).

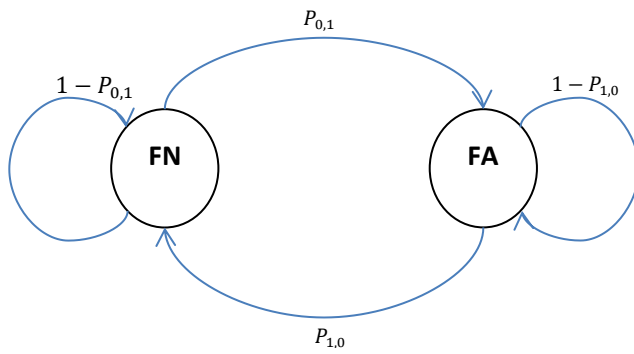

Figure 2.9 Two state Markov model

In previous applications of Markov models applied to intermittent faults the purpose has been to evaluate intermittent testing regimes, more specifically to determine the time required to spend testing each connection to ensure maximum probability of the system entering a faulty state during that test.

In previous applications of Markov models to the intermittent fault case the assumption has been made that the occurrence of intermittent faults follows a stationary process [5]. However, this does not capture the implicit natural behaviour of intermittent as laid out in section 3.2. The notion of intermittent fault dynamics ensure that there is an ongoing variation in the intermittent occurrence process – that is the changing between faulty and healthy states can be considered as not stationary. The probability of transition between a healthy and faulty state in the case of intermittent failures will not be consistent and new modelling techniques are required to capture this dynamic transition of probability.

2.4.5 NFF Models

Despite significant improvements in various engineering disciplines of measurements, programming, and computing, there is still a lack of adequate knowledge in modelling NFF. In particular, meeting requirements that are highly needed to detect NFF of wires, and connections. However, while there are general modelling approaches, they are hardly acceptable to be used for wired communication channels, considering various issues arising from noise, vibrations, temperature and degradation. The two approaches that have been already employed for modelling NFF of communication channels are Aircraft Wiring Model (AWM), and TDR. AWM is US aviation research that attempts to model an aircraft's electric power wire using distributed passive components (resistance, inductance, shunt capacitance and shunt conductance) found in transmission lines. In Figure 2.10, dx is the length of the wiring segment with R_{dx} series resistance and L_{dx} series inductance. A shunt capacitance C_{dx} is associated with dielectric, and shunt conductance of G_{dx} is associated with dielectric in this figure. Components' values are defined per unit length and are considered as a single lumped element whose value is dependent upon total length of wires.

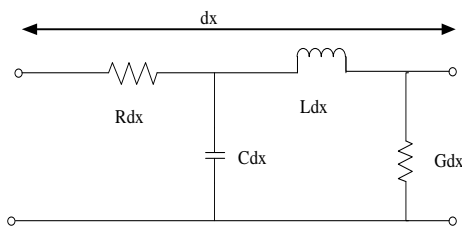

Figure 2.10. Aircraft Wiring Model (Alstine & Allan, 2005)

The inductance, (L_{dx}), is a function of the physical properties of the wire and, for installed wiring, can be assumed to be constant. The capacitance of a wire, (C_{dx}), is a function of geometry, the insulation materials, and the presence of any

contamination. Yaramasu et al have used the same AWM wiring model of an ageing aeroplane in their research by adding load resistance to it for Time Domain Reflectometry (TDR) (Yaramasu, et al., 2012).

In this work, it is presented an intermittent interconnection and detection model (IIDM) that consists of source, wire, IF detection, as shown in Figure 2.11.

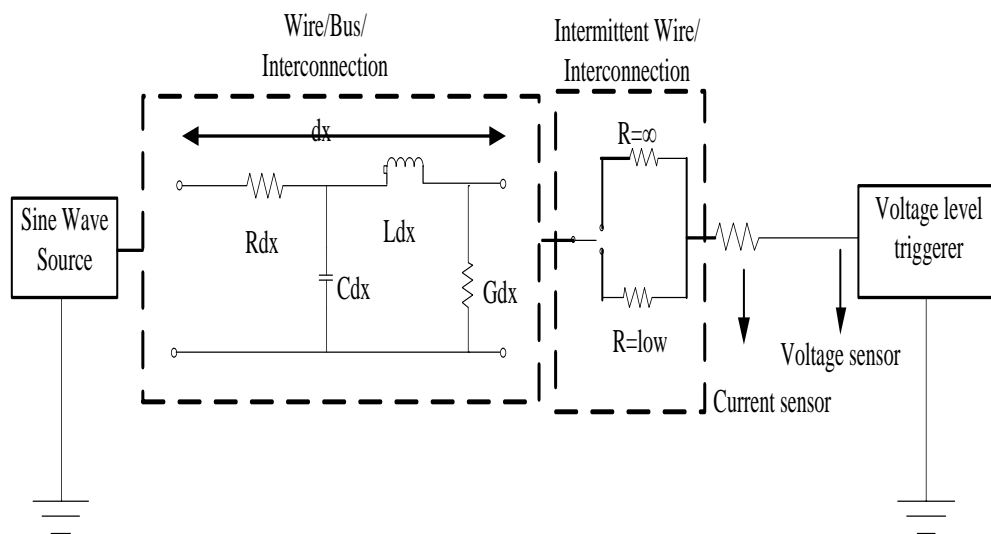

Figure 2.11. NFF/Intermittent Interconnection and Detection Model

In this IIDM, an intermittent fault is modelled by two parallel resistors with a switch. In normal operation, it follows a low-resistance path while an intermittent open path has high resistance. In this model, only an intermittent interconnection are included due to vibration only.

2.5 Summary

This chapter starts with NFF survey and presented its different causes with their impact to conclude the research gaps. It shows that electronic/electrical interconnections are major contributor of NFF. It is concluded from literature review that this research will focus on intermittent fault detection for wire harnesses and

connectors i.e. interconnecting systems. The existing techniques are highlighted with their limitations to narrow down this research to improve diagnostic capabilities.

Next section starts with fundamental concepts of faults. It gathered an intermittent fault modelling and NFF fault dynamics of existing models and adopted for interconnections systems. A novel model of interconnecting system for electronics has been described that can be used for fault detection in interconnecting systems.

2.6 Contributions

- Literature review
- NFF model

3 INTERMITTENT CONNECTION FAULT GENERATOR (TEST RIG)

To carry out an experimental investigation on intermittent fault, it is essential to have a fault replicator that can produce this kind of faults. Intermittent fault is unpredictable and less often but for experimental study a test ring is adopted that can produce "on/off" i.e. more often intermittent connection. This chapter describes two novel intermittent fault generators, known as IF test rigs, which can produce IF repeatedly. It also discusses the comparison of different fault diagnostic equipment to validate fault generator and discusses about the test equipment for further research of IF detection technologies.

A test rig that consist of IF generator (single point and multipoint) and different test equipment are used for comparison and suitability for IF analysis. Single point IF generator repeatedly produces intermittency under vibration is mad of wire and spring connector. The oscilloscope, Pico-scope (PC based oscilloscope) and Copernicus's N-Compass equipment (IF detection equipment) are used to capture the intermittency. In this initial investigation one wire and one connector has been used but it also describes a multipoint test rig made of RJ45 connectors with Ethernet cable.

3.1 Single Point Test Rig

To generate an intermittent connection a shaker has been used to shake an interconnection that can produce intermittency in the interconnecting circuit. A shaker with power amplifier has been used, as shown in Figure 3.1, to produce cyclic intermittency. This equipment is made of Data Physics Company for experimental study and measurements in laboratory. It takes input signal from power amplifier and

vibrates accordingly. This amplifier has a variable knob to select the amplitude of oscillations. Power amplifier could only be excited by external signal generator and it oscillates with same excitation frequency. Smooth or jerky vibration could be applied by selecting sinusoidal or square wave signals from external signal generator.

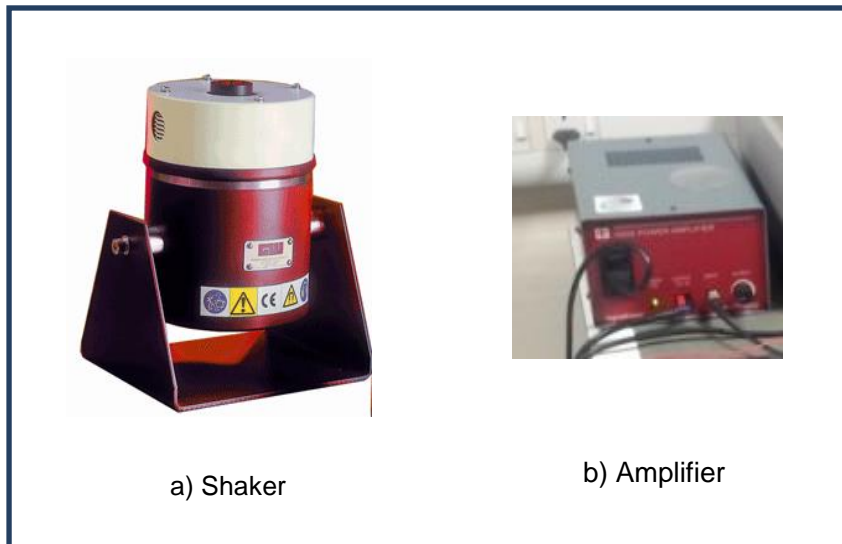

Figure 3.1 Shaker for Intermittent Fault Generator

A spring hook is used to hold the wire in such a way that the wire connection can be vibrated under the external vibration as shown in Figure 3.1a. All the components of connector kit that includes the assembly to attach on the shaker are also shown in Figure 3.2 and these are bracket and grid tile.

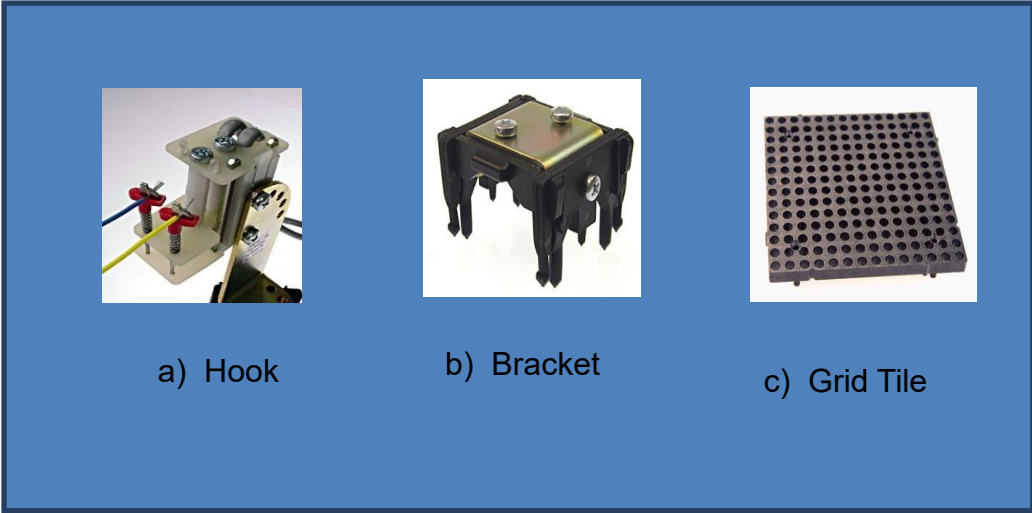

Figure 3.2 Components of intermittent fault generator

The connector assembly is attached to the bracket (Figure 3.2 b) and is locked into grid tile (Figure 3.1 c). The grid is attached to the shaker to apply variable vibrations on spring connector as shown in Figure 3.3

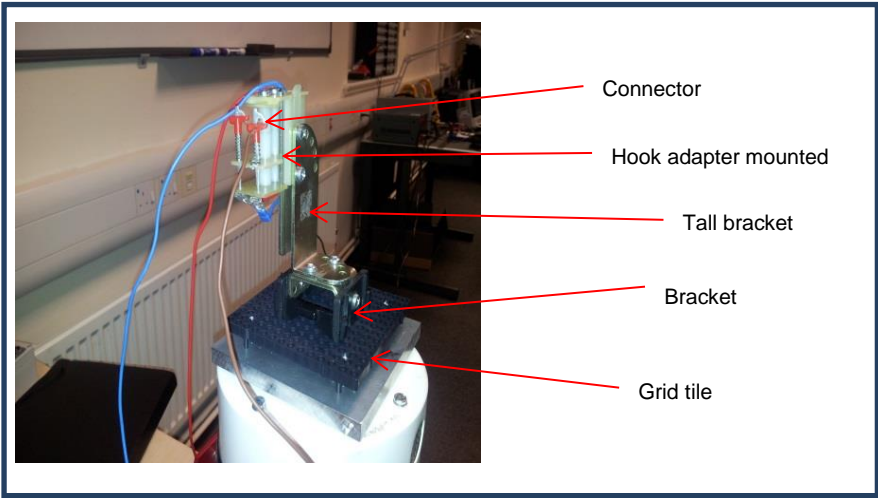

Figure 3.3 Single Point Intermittent Fault Generator

3.2 Comparisons of Test Equipment and Verification of Intermittent Generator

A verification of intermittent connection generator is done using an experimental. It verifies the functionality of intermittent connection. Oscilloscope, pico-scope and N-compass have been used to detect / monitor intermittent faults. Oscilloscope / pico-scope is general purpose diagnostic equipment but N-compass is bespoke special equipment used for IF detection in aerospace industry.

3.2.1 N-Compass

It can be used to detect 256 intermittent connections but here it is used for single point, to explain fundamental problem of IF. This explains an intermittent connection. The full setup, with shaker, spring connector circuit and N-compass intermittent diagnosing equipment, is show Figure 3.5.

N-compass can be interfaced through parallel port / old printer port to PC and results of emulation are displayed on the monitor screen. An interface card is made to interface the N-Compass to test rig through parallel test port in N-compass consol. Experimental setup schematic diagram can be seen in Figure 3.4 and physical diagram for this experimental is shown in Figure 3.5.

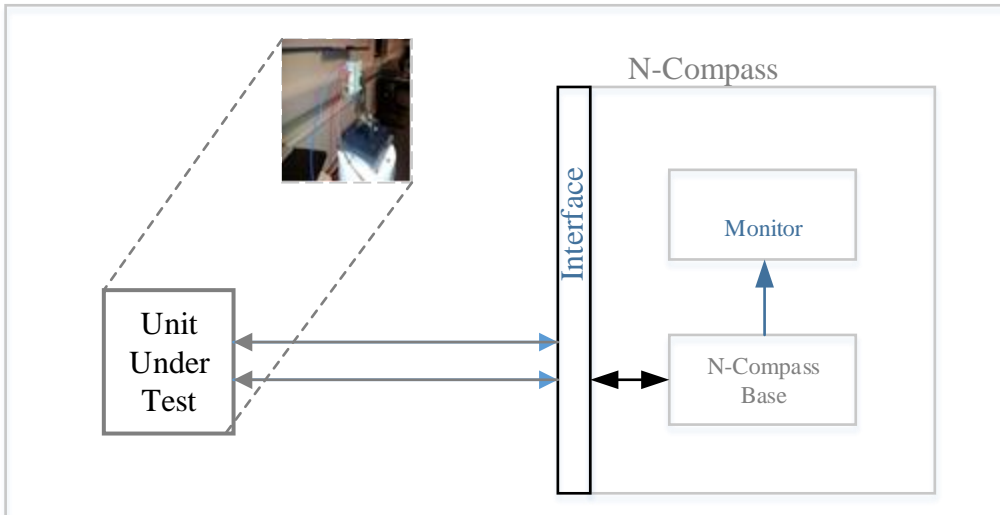

Figure 3.4 Experimental Setup Diagram

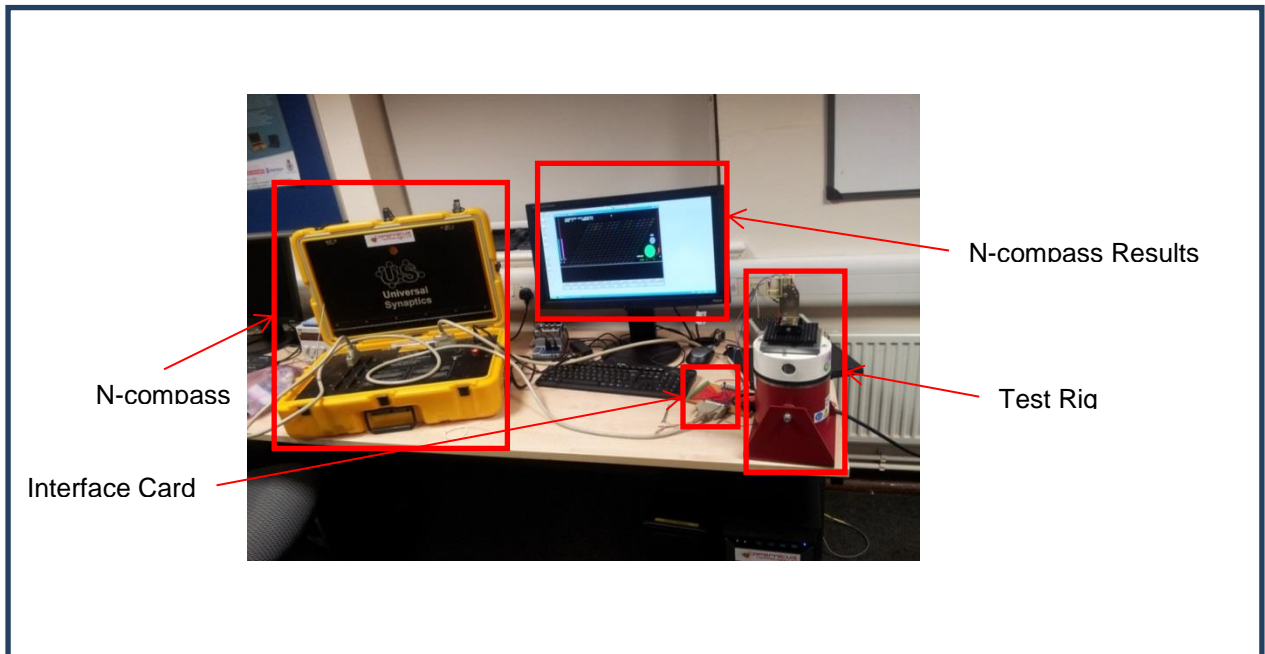

Figure 3.5. Experimental setup to monitor intermittency using n-compass

Universal Synaptic equipment is specially designed to capture electronic intermittent connection in electronic/electrical circuits and it is called N-Compass. N-Compass can monitor 256 channels simultaneously for multipoint intermittent fault detection when circuit is offline.

It can capture very sharp intermittent transients and latch them as intermittent fault. It has a variable threshold to set the sensitivity for intermittent fault detection.

Although it can monitor 256 points but here only used one point for this experiment to demonstrate single connection intermittency.

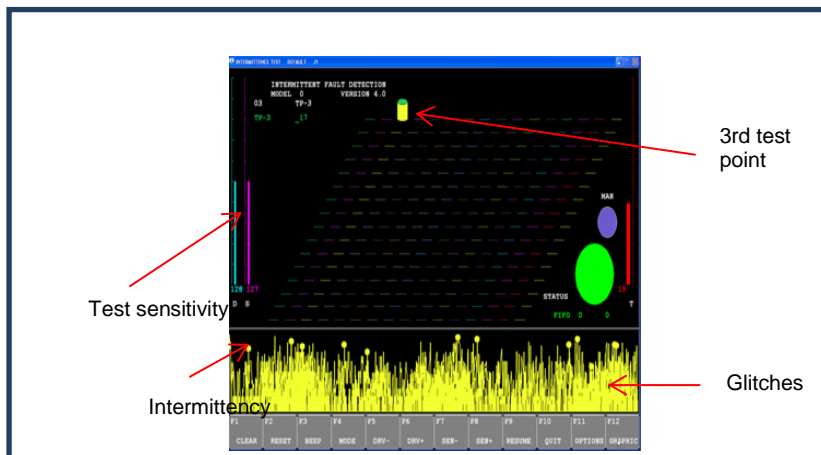

Figure 3.6. N-Compass displaying intermittency in the circuit

The complete circuit setup for this experiment is shown in Figure 3.11. The vibrating connector's circuit is connected to the N-compass through interface card and pin configuration is defined in the N-Compass software.

The repeatedly intermittency with yellow glitches / noisy signals with dotted heads can be seen in

Figure 3.6. The yellow dotted heads on some spikes indicates the intermittency in the circuit. The horizontal dotted lines indicate the all possible test points of N-compass. The only used single test point at location (1,3) of display coordinates shows the magnitude of intermittency with yellow bar. The sensitivity i.e. threshold could be

changed per require test by pressing F2 key on keyboard. This level is show in Figure 3.6

3.2.1.1 How N-compass Works

This section explains how N-compass detects IF, using an experimental measurement by oscilloscope measurements.

Ethernet socket (RJ45) was attached on the vibrating end of shaker with the help of grid assembly. The connection between socket and plug produce intermittent faults under vibration. Intermittent fault generator circuit was connected to test equipment and to oscilloscope. It was measured from oscilloscope that intermittent detection equipment is transmitting 0.543 MHz frequency of sinusoidal waves as shown oscilloscope figures in Figure 3.7 and Figure 4.13. This shows that the sine waves are not very precise and there is also lot of frequency jittering. It is noted that when circuit is open and Ethernet cable is unplugged the amplitude of sine wave is almost 200mV peak to peak as shown in Figure 3.7.

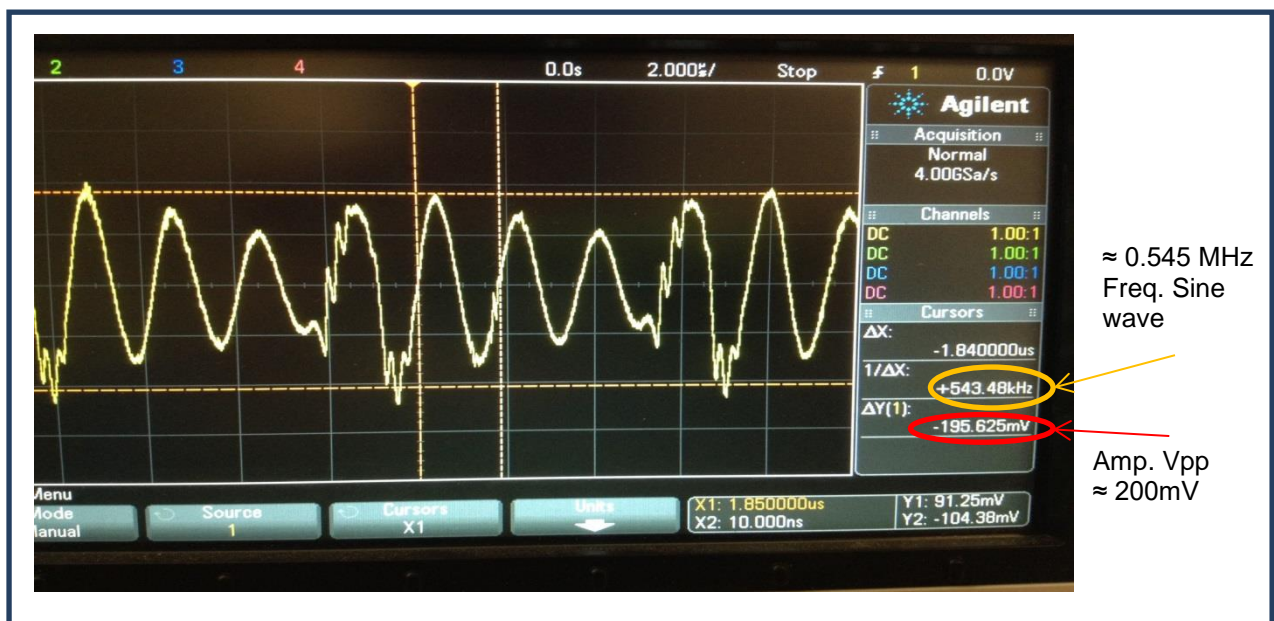

Figure 3.7. Test Signal of Open Circuit.

When circuit is closed and Ethernet cable is plugged into the socket the amplitude of the sine wave dropped to almost 50mV peak to peak this is shown in Figure 3.8.

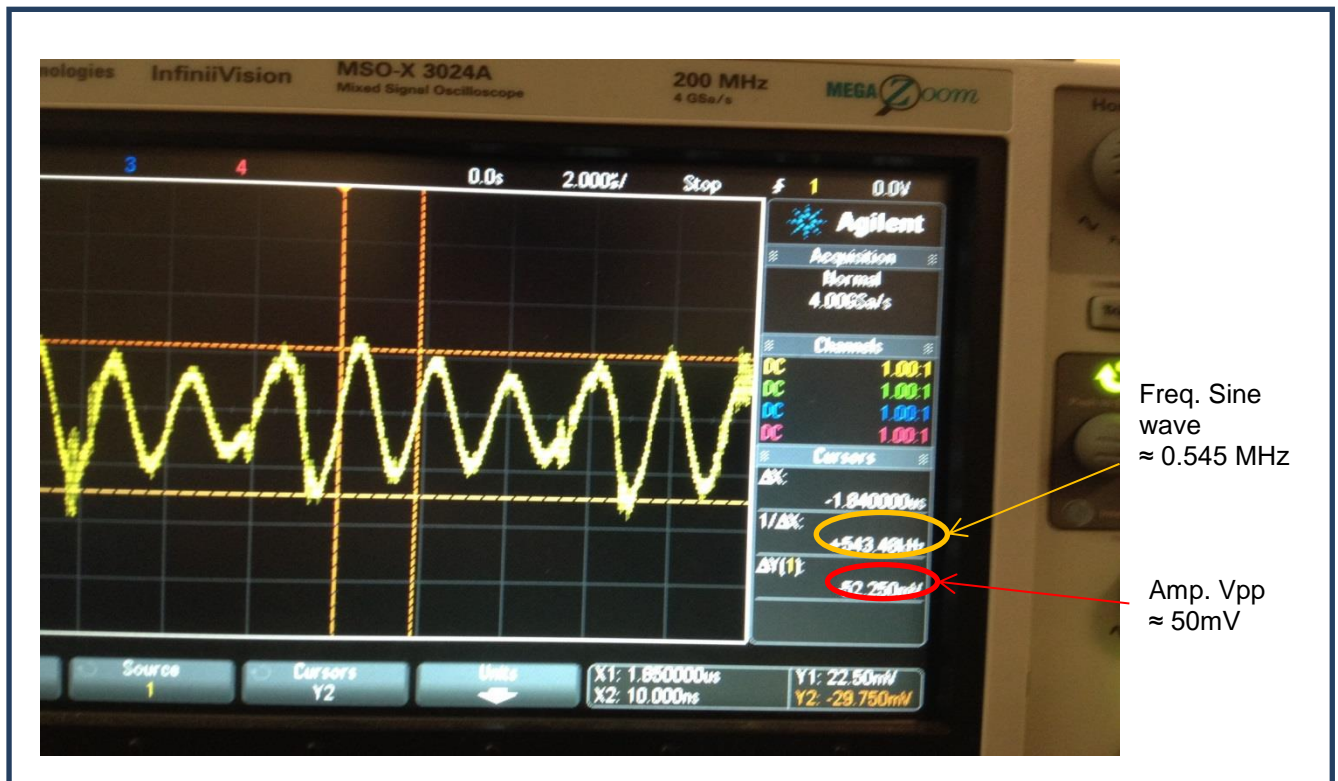

Figure 3.8. Test Signal for Close circuit

This variation of close and open circuit is used to detect the intermittent fault by threshold trigger circuit. When circuit is connected, it drops the voltage across resistance due to current flow in the load. When circuit disconnected, it breaks the flow of current and output voltage increases to its supply voltage. This phenomenon is used to detect the intermittent discontinuities.

3.2.2 Pico-Scope

The pico-scope is a PC base oscilloscope/ spectrum analyser. It has three modes of operation called scope, persistence and spectrum. Persistence mode is very useful

for getting intermittent fault data. In this mode, it displays the less dense and more frequent data in different colours. The software display of pico-scope in persistence mode is shown in Figure 3.9. Blue transient data shows the less frequent/dense data whereas red colour indicates the dense and more frequent data. Intermittent or transient signal will appear in blue colour.

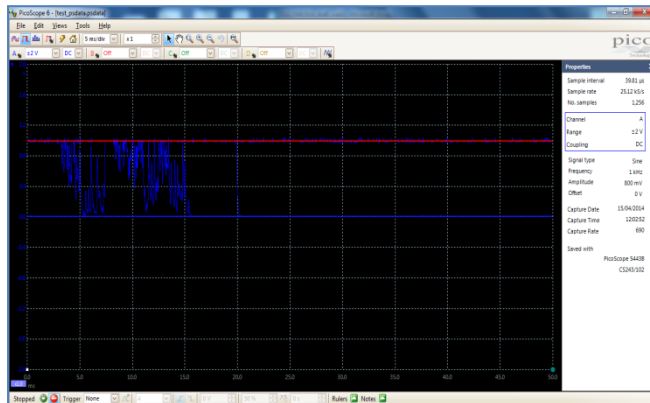

Figure 3.9. Picoscope persistence mode

Figure 3.10 shows the persistence mode using various colour-coding or shading to distinguish frequent and infrequent data. One can arrange for previously used data to fade away after a specified time or to remain on the display until you erase it. Persistence mode has two advantages: it allows the scope to capture waveforms faster than it can update the display, and it makes it easier to spot transient / intermittent events.

The red colour indicates the densest areas of data where most waveforms are located. The coolest colours i.e. blue indicate transient events such as glitches and jitter.

The capture rate depends on the scope settings but is usually many thousands of waveforms per second. The display rate is typically 10 to 20 updates per second in

this mode, although this is of little importance because each waveform persists for a long time on the display. In fact, with the persistence time set to infinity, you can leave pico-scope running overnight and still be sure of catching intermittent transitions.

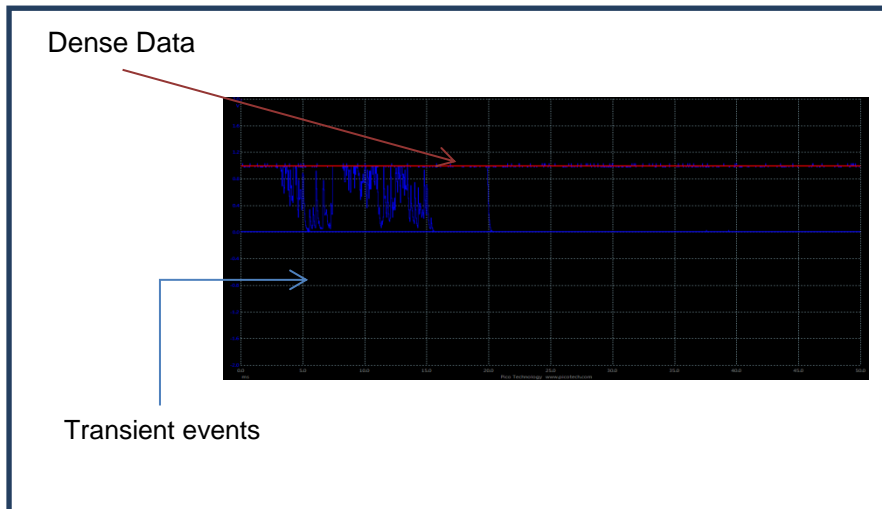

Figure 3.10. Persistence display mode

Persistence mode has allowed us to see transient data, that was practically invisible in real-time mode, and gives us a qualitative display of its rate of recurrence as shown in the Figure 3.9 and Figure 3.10.

3.2.3 Oscilloscope

A digital oscilloscope of 4 G bits/S sampling frequency with 200 M Hz bandwidth has been used to monitor the intermittent transients for this measurement. The connector is given a 20 Hz vibrations stress by feeding the pulse from oscilloscope's built-in signal generator to shaker the amplifier. Measurement has been done by using an oscilloscope and this setup is shown in Figure 3.11.

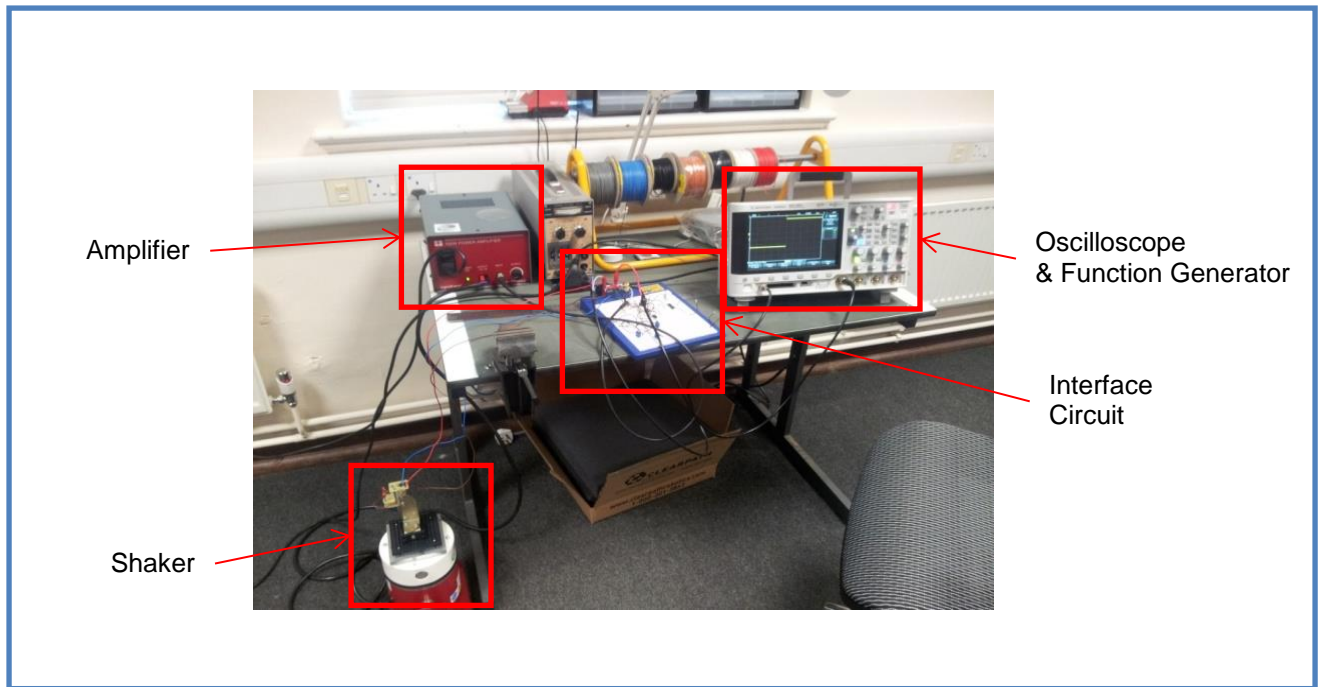

Figure 3.11. Experimental setup to monitor intermittency using oscilloscope

A 20 Hz and 2 volts peak to peak square pulse has been applied as stimulus to the circuit and its output is observed as shown in

Figure 3.12. The oscilloscope fails to capture the intermittency despite little spikes that could be due to noise.



Figure 3.12. Oscilloscope to monitor intermittency

3.3 Multipoint Test Rig

This section describes multipoint intermittent test rig and some experimental results to show how it could be used as multipoint IF generator. It validates intermittent connection with N-compass. Last section describes how N-compass works using oscilloscope measurements.

Intermittent fault detection equipment detects an intermittent fault in interconnection only if it completely breaks the circuit for very short duration, ideally resistance of connection change from very small value to infinity. Ethernet socket's pint under vibration bounces and some on them disconnects / connects to make intermittent connection.

Ethernet connection assembly is used to produce the intermittent fault as shown in the Figure 3.13. It consists of Ethernet male and female socket attached to shaker with same bracket and grid titles as described for single point test rig.

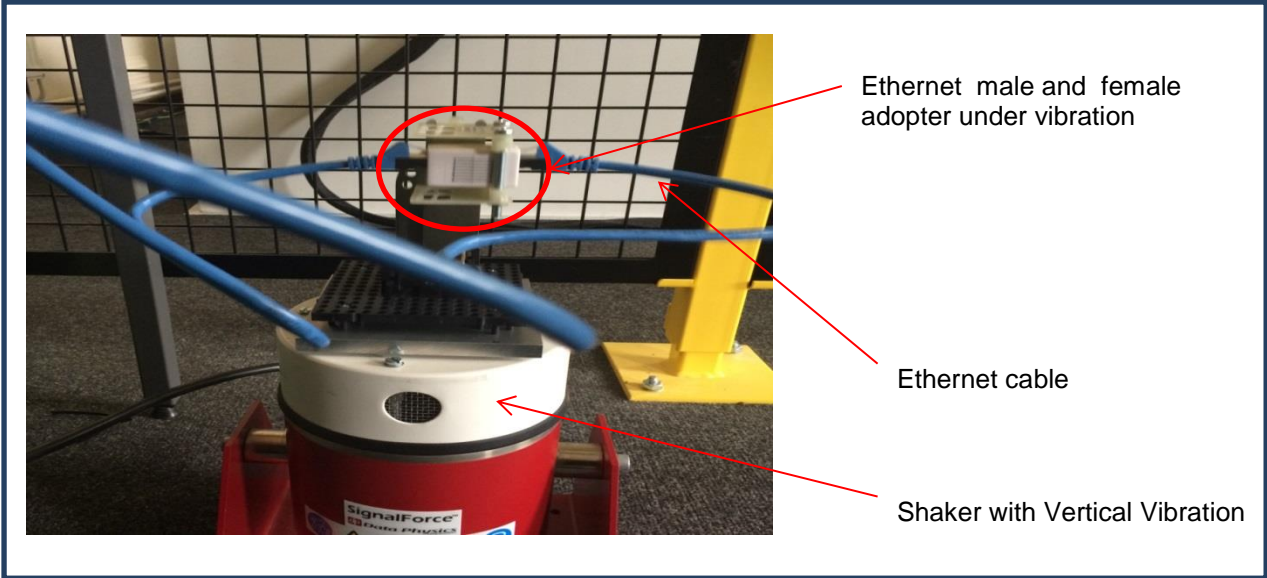

Figure 3.13 Multipoint Ethernet Intermittent Test Rig

Only N-compass is used for the verification of this multipoint test rig because it has capability to test multipoint simultaneously. This removes any chance to miss any intermittent instant. Oscilloscope and pico-scope cannot be used to test multi-points

intermittent connection. Experimental test setup is similar as described for single point test rig, apart from attached Ethernet socket / cable on shaker.

This multipoint test rig has been verified using N-compass and results are displayed in Figure 3.14. Test results five connections are displayed in this figure.

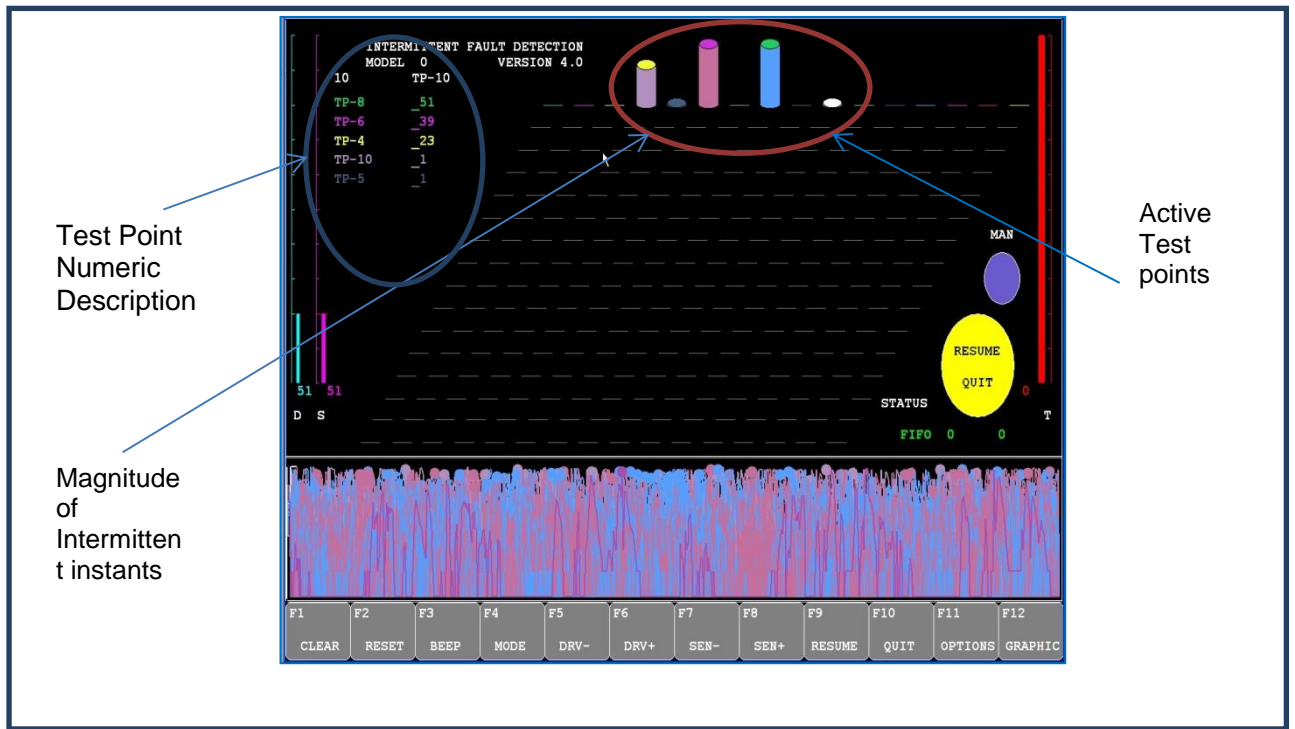

Figure 3.14 Test Results for Multipoint Intermittent Generator

3.4 Contribution

This chapter presents a novel intermittent connection test replicator that can replicate IFs as test bed. Single and multi-point circuit intermittent connection have been developed and this is fundamental contribution for IF study. It also compares different test equipment and shows, why general purpose equipment is not suitable for intermittent connection monitor. This also shows that bespoke equipment for single / multi point IF detection and its limitations for root cause analysis. It highlights research gaps for further research.

4 LADDER NETWORK FOR INTERMITTENT FAULT DETECTION

There are various occurrences and root causes that result in No-Fault-Found events but an IF is most frustrating, and IF. This chapter describes the important area of IF detection and health monitoring that focuses towards No-NFF situation in electronics interconnection system. The experimental work focuses on mechanically induced intermittent conditions in connectors. This work illustrates a test regime which can be used to repeatedly reproduce intermittency in electronic connectors whilst subjected to vibration. A novel ladder network algorithm is used to detect an intermittent connection in electronics systems. It sends a sine wave to ladder network and decodes the received signal for intermittent information from the channel. This algorithm has been simulated to capture IF finger prints using a Spice (electronic circuit simulation software). Simulated circuit is implemented for practical verification however measurements are presented using an oscilloscope. The results of this experiment provide an insight into the limitations of existing test equipment and requirements for future intermittent fault detection techniques. Aside from scheduled maintenance this chapter, speculate, the possibility for in-service intermittent detection that is built into future systems i.e., can intermittent faults be captured without external test gear?

4.1 Introduction

Most devices and systems contain embedded electronics modules for monitoring, control, and to enhance the functionality of cars, trains, ships and aeroplanes. The shrinking size and complexity of electronic circuits, with added redundancies, have led to difficulties in the maintenance of these systems. This becomes a challenge when faults are intermittent in nature.

Intermittent faults (IFs) are a growing problem in electronics interconnection system especially for aircraft, satellites, and other vehicle industry and are safety critical for unmanned/ autonomous connected vehicles. Interconnections have increased significantly in modern systems and these are prone to high stress of temperature, humidity, power fluctuation, electromagnetic interference, critical timing, aging, vibration and others.

NFF has financial impact on all industries, but transport and aerospace suffer more than others (Söderholm, 2007). The American Trans Air (ATA) member airline cost \$100 million annually on NFF and cause thousands of flights delay and cancellations (Beniaminy I., 2002) plus the cost of aircraft troubleshooting and recovery. The included cost per fleet will become millions of pounds.

The fundamental problem of NFF has been highlighted and it focuses on its main cause of an intermittent fault for electronics sockets, wire-harnesses, wires and printed circuit boards (PCBs) i.e. electronics interconnection systems. It describes that intermittent fault could be detect able with high accuracy and with

minimum false alarms that happens in existing intermittent continuity test or health monitoring system.

When the fault is consistent, it is not difficult to isolate and repair; however, this is not true for faults that occur intermittently. In general, component degradation cause in these faults to worsen with time, until they eventually cause a hard fault. (Bryan, et al., 2008).

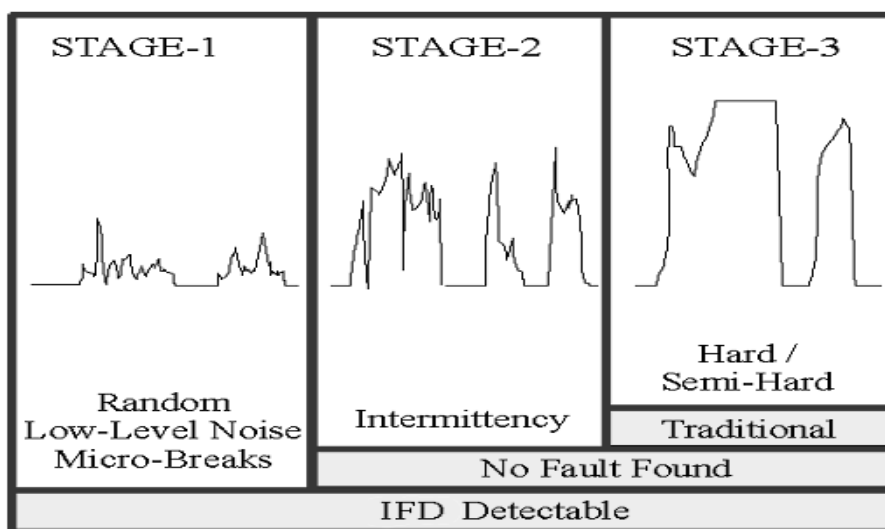

Figure 4.1. Intermittent Fault Detestability (Bryan, et al., 2008)

Figure 4.1 illustrates that at very early stage of degradation there are very weak unwanted signals but it does not affect system's performance. This grows and causes intermittent problems, before system stops working. For safety, critical applications, these must be addressed to avoid malfunction.

To enhance system reliability and safety interfaces/interconnections, must be monitored, all the times during operation. As the nature of IF is random and unpredictable so there should be a health monitoring system that could monitor

all points with minimum added redundancy. The resolution of health monitoring system could be selected per requirements. The AC sinusoidal signal is suitable due to channel's noise characteristics to avoid false alarms.

Modelling for early fault detection of intermittent connections on control area network has been presented by Zhao and Lei (Zaho & Lei, 2012). Author has monitored data errors for control area network (CAN) to detect intermittent fault. This technique work on data communication link with assumption that data error in CAN are only due to intermittent discontinuities. This paper ignores the facts that data error could happen due to inter symbol interference, non-synchronisation, high noise level; added redundancies can also cause intermittent malfunction and give data errors. Other limitation of this algorithm is that it is application specific and can only be used for CAN and cannot be used other interconnection systems.

A novel intermittent fault detection algorithm is presented to overcome above limitations. A physical layer is used to avoid possible transport layer false alarms. This novel algorithm detects intermittent faults in wires/wire-harnesses, interfaces, and other electrical/electronic interconnections. This could be used to monitor data cables, PCB's and connection sockets or other electronics interconnections. This approach is unique and different from previous diagnostic method of interconnection fault detection; it sends sinusoidal signals and health monitoring system detects an intermittent fault when it happens. This technique reduces the false alarms with adjustable resolution per requirements.

Next section describes novel ladder network algorithm with discussion on test resolution and why AC is better than DC signal for intermittent diagnosis. Third section describes its Spice simulation with some useful discussion to improve and enhance fault detection by Fourier analysis. Subsequent section (4) describes validation of designed technique with an experimental work. with measurements.

4.2 Ladder Network Algorithm

Ladder network use the intermittent node to change the amplitude voltage level. This is resembled to very basic form of communication system that use the amplitude modulation..

Ladder network is being used to capture intermittent interconnection signature. It modulates amplitude variation, due to intermittent connection, to a sinusoidal signal by using ladder network. This is illustrated in a block diagram, as shown in Figure 4.2. It consists of an input carrier voltage signal, an IF amplitude modulating (AM) ladder network, a demodulation circuit, a voltage sensor and IF latching sub-blocks. Voltage source sends the sinusoidal signals that act like a carrier signals to detection system. Detection system only change the carrier amplitude if there is an intermittency otherwise it will not alter it. This is similar in telephone line that if one keep quiet or silent then carrier remain constant but it only change when someone is speaking. In this case talking mean intermittent connection and silent mean no IFs.

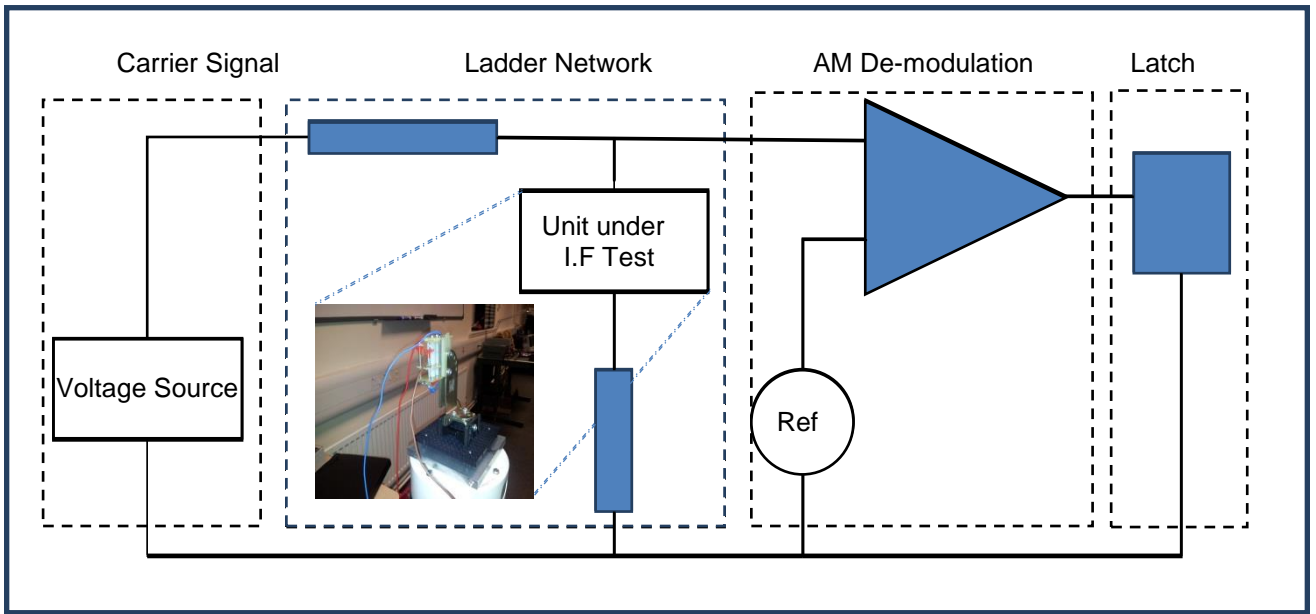

Figure 4.2 Ladder Network IF Detection Block Diagram

Function generator sends a sine wave of constant amplitude, and frequency as a source to ladder network that includes unit under IF test. If there is an intermittent discontinuity, it will make carrier signal discontinue. This will change the amplitude of the carrier signal. This discontinuity acts like a modulating signal and will add to carrier to make a modulated signal. At the receiving end de-modulation circuit removes the carrier frequency to get the intermittent discontinuity. This block diagram is shown in Figure 4.2.

Let V_s is carrier voltage and V_n, V_n' are the voltages at sensor node "N" with normal and intermittent open. If $V_s = A \sin(2\pi ft)$, then

$$V_n = \frac{Z_2 A \sin(2\pi ft)}{(Z_1 + Z_2)} \quad (1)$$

and $V_n' = V_s \quad (2)$

Where Z_1 and Z_2 are impedance of the circuit and A is amplitude. If $(V_n, V'_n) < V_{ref}$, then

$$V_{out} = X \quad (3)$$

and if $(V_n, V'_n) > V_{ref}$ then

$$V_{out} = Y \quad (4)$$

In these equations, V_{ref} is a reference voltage and V_{out} is the output of the circuit.

Whenever there is fault, output will change a state from X to Y .

This system has been modelled as a two-state machine, as shown in Figure 4.3.

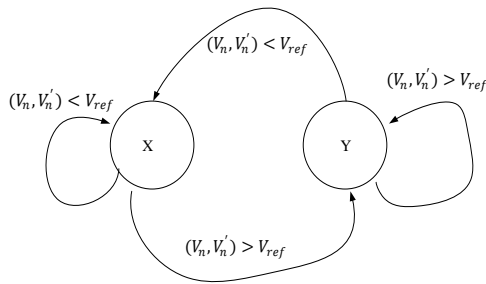

Figure 4.3. State Representation of Intermittent Fault Detection System

This algorithm can be explained by using a flow diagram, as shown in Figure 4.4.

The carrier sends electrical signals to the unit under test continuously and monitors the demodulated signal's amplitude. If there is an IF, it latches the fault.

The fault will only be captured when it goes from state $X (V_{ref})$ to $-Y(V_{ref})$ and from $Y(V_{ref})$ to state $X(V_{ref})$. The reference voltage V_{ref} determines the sensitivity

of fault detection that depends upon the testing system that how noisy is it.

Operational test engineer should adjust this. The next two sub-sections explain how this algorithm improves the detectability with precision.

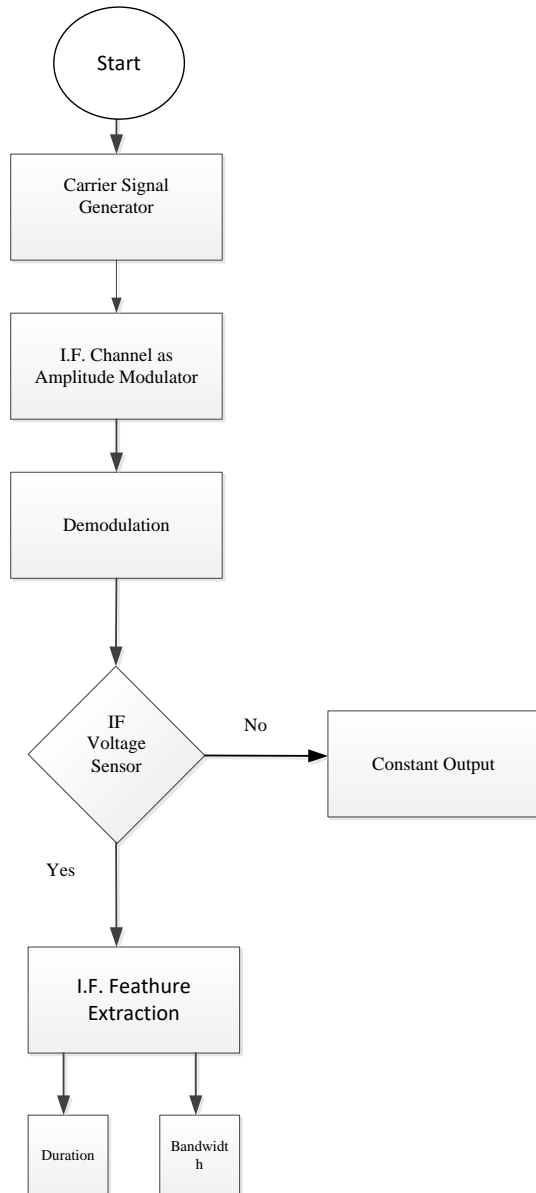

Figure 4.4. Intermittent Fault Detection Algorithm

4.2.1 Resolution of Intermittent Test

This section discuss how sharp intermittent faults could be captured by a carrier frequency of “ f ” Hz with a close circuit amplitude of $\pm a$ and an open circuit amplitude of $\pm A$, respectively, and the voltage sensor reference level at $\pm V_{ref}$ volts. The ratio between the threshold and the peak sine voltage is $\frac{V_{ref}}{A}$.

The angular frequency (ω) of the input sine wave is = 2π times linear frequency (f) i.e $\omega=2\pi f$ where ω is in radians and f is in Hz.

$$\omega = 2\pi f \quad \text{radians}$$

Time of signal below of threshold is

$\sin \omega t = h/A$ where A is the peak amplitude and h is the threshold amplitude of the sine wave.

$$t = \sin^{-1} h/A \text{ seconds}$$

The resolution to detect the intermittent change will be $2t$ because the sine wave will remain below for positive and negative threshold of sine wave.

In the test setup, the sine peak is adjustable to increase / decrease the resolution if required by simply increasing the sine wave peak amplitude and decreasing the voltage divider ration such that it remain below the threshold for close circuit i.e. under normal condition.

If increase the peak voltage from A to $2A$, will get $\approx \frac{t}{2}$, i.e. almost half the time by doubling the sine wave amplitude.

This threshold level could also be used to change the intermittent fault capturing precision, as discussed previously.

The other way to increase the detection resolution is to increase the input frequency from f to $2f$. This will almost narrow it to half and double the resolution.

4.2.2 The Need to Use AC Rather than DC Signals

Direct Current (DC) could be used to capture very small transients but this is not desired due to white, thermal, and particularly flicker noise. For DC measurements, flicker or $1/f$ noise can be troublesome as it occurs significantly at low frequencies, tending to infinity with integration/averaging at DC. Flicker noise, also known as pink noise, is inversely proportional to frequency, i.e. $S(f) \propto \frac{1}{f^\alpha}$ where f is frequency and $0 < \alpha < 2$, usually close to 1.

Intermittent faults in interconnects are due to disconnection of circuits for very short durations but not due to other noise. IFs in vehicles are mainly due to vibration or other means of loose connections and that could not be small as pico seconds because engine do not vibrate at such high frequencies. This means that a connection cannot generate a Giga Hertz signal, but further investigation is needed to develop better understanding to quantify the frequency of the most common intermittent faults.

Intermittent faults can only be detected if there is a disconnection of the circuit for a short duration, An alternating current (AC) signal is the best choice to avoid

other non-loose connection triggers. The frequency could be selected according to requirements.

AC signals could also be used in-situ to detect an intermittent fault but the health-monitoring system must be operated at different bands of frequency of the system.

The power dissipation of AC signals is less than that of DC signals and the probability of false alarms is also lower. One of the main benefits is its use for health monitoring of high-value products.

4.3 Ladder Network PSpice Simulation

This algorithm is simulated using Spice software with two profiles: one with a closed circuit and another with an open circuit to illustrate intermittent connections. This is shown in Figure 4.5. In the first profile, the connection is simulated by a closed switch and it simulates carrier signal only but in profile 2 there are intermittent modulated faults.

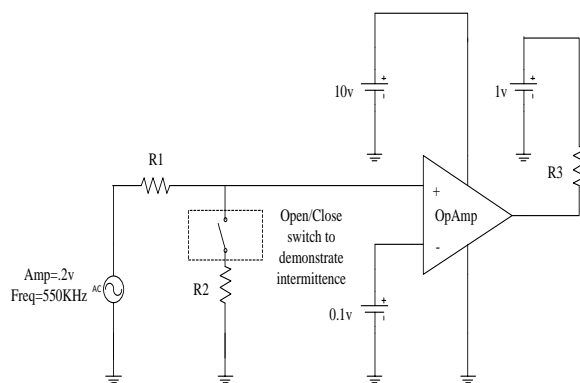

Figure 4.5. Intermittent Fault Detection Circuit Schematics

These parameters of source frequency, R1, R2 and 0.1V threshold are selected to give suitable resolution. The ratio of R1 and R2 is 3 to 1 and 550 K Hz sine wave. More details on these have been described in section 4.2.1.

The simulations results are shown in figures below. In these figures, the green marker (dotted line) shows the input signal and the red marker (solid line) shows the output of the circuit across R3. There are ripples in the output but these do not affect the threshold level trigger points.

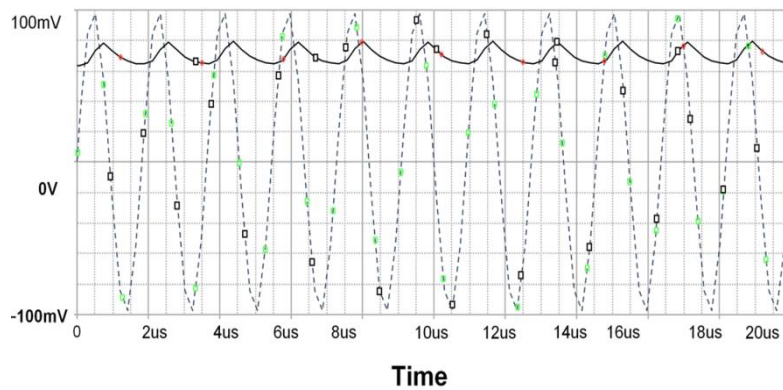

Figure 4.6. Input / Output Wave Form of Intermittent Fault Detection Circuit – Profile 1

The frequency domain plot is shown in Figure 5.7, where the input signal's Fast Fourier Transform (FFT) at a centre frequency of 0.55MHz and a magnitude of 100mv or -20dbV while the output frequency plot (solid) of $\approx 5\text{mv}$ or -46dbv is present. These small signals are far below the threshold point that could be used to latch at latching circuit.

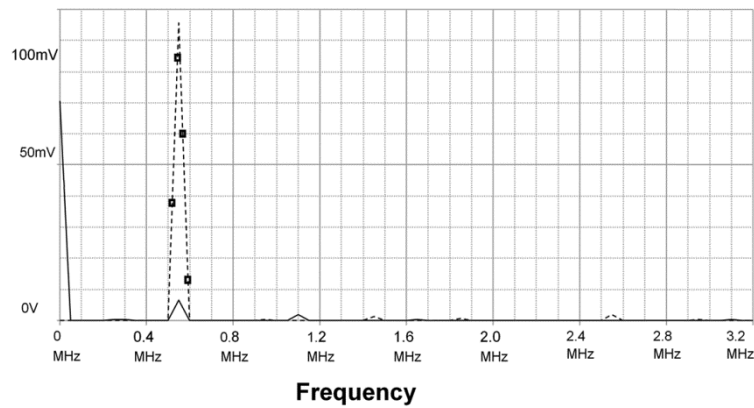

Figure 4.7. Frequency Domain Plot of Input (dotted)/Output(solid) of Profile 1

When the switch is open in the circuit, the voltage at the node increases above the threshold point. This increase will exceed the reference voltage and it triggers the output. The comparator output is pulled up to 1v through resistor R3, as shown in Figure 4.5. The simulation measurements of output voltage are carried out across this resistor, while input marker shows the voltage at sensor node between Ra and R2.

The simulation result of profile 2 is shown in Figure 4.8. The input signal in green marker and the output signal in red marker shows that when the input voltage exceeds the reference voltage of 0.1 v, it produces the square wave.

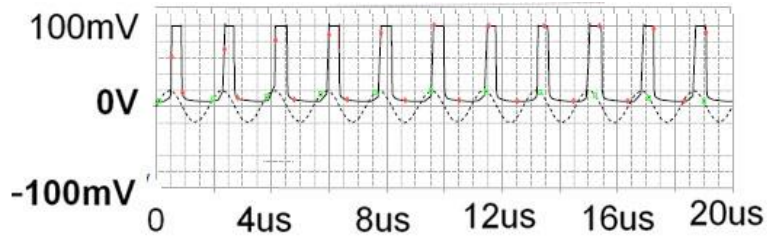

Figure 4.8 simulation of profile 2

The Fast Fourier Transform (FFT) of the input and the output of profile 2 are shown in Figure 4.9 and 4.10 respectively.

Figure 4.9 shows a narrow band input carrier frequency at 550 kHz and Figure 4.10 shows three major frequencies at 550 kHz , 1100 kHz, and almost 1,600 kHz with other noise components

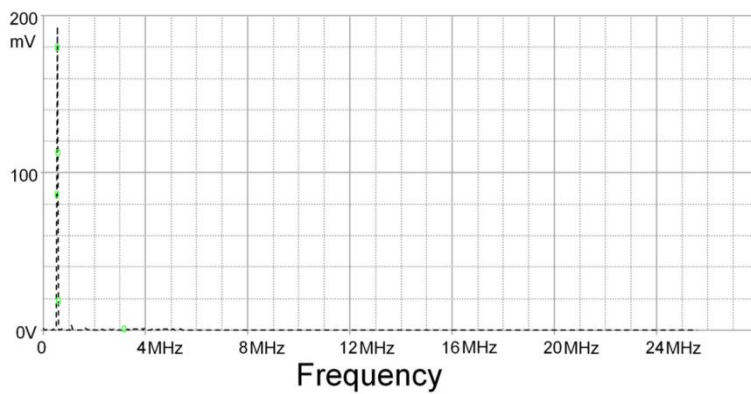

Figure 4.9. FFT Plot of Input Signal of Profile 2

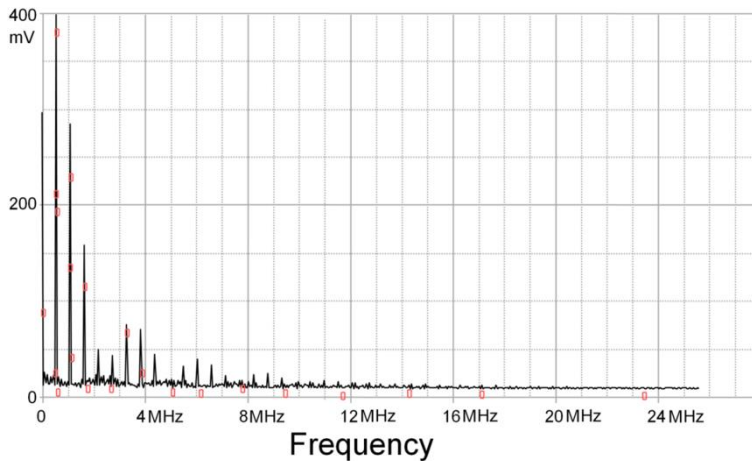

Figure 4.10. FFT Plot of Output Signals of Profile 2

4.4 Experimental Verification of Ladder Network Algorithm

The algorithm described in the previous section has been verified with an experiment. It is tested/verified on mechanically-induced intermittent faults. The details of the test rig and measurements are described in the following subsections.

4.4.1 Experimental Setup and Circuit

An RJ45 Ethernet socket with an Ethernet cable/plug under external vibration is used to generate intermittency in the connection as shown in Figure 4.11.

The grid has been installed on the shaker by screws and a metal plate, as shown Figure 4.11. This Ethernet connection assembly is used to produce the intermittent fault under vibration.

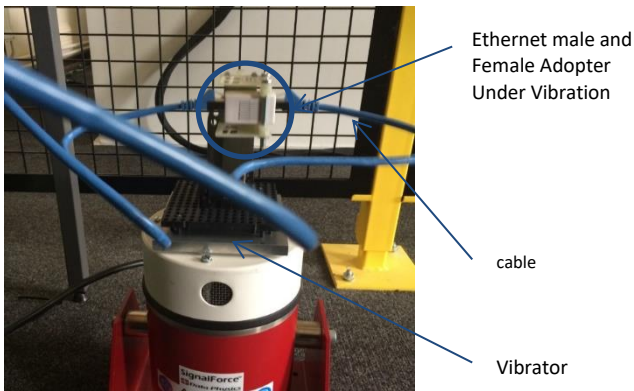

Figure 4.11. Ethernet Male and Female Socket with Cable Connection as an Intermittent Test Rig

The other ends of the Ethernet cable are connected to a circuit. A complete circuit setup is shown in Figure 4.12. It consists of a test rig, oscilloscope, dual power supply and a prototype board.

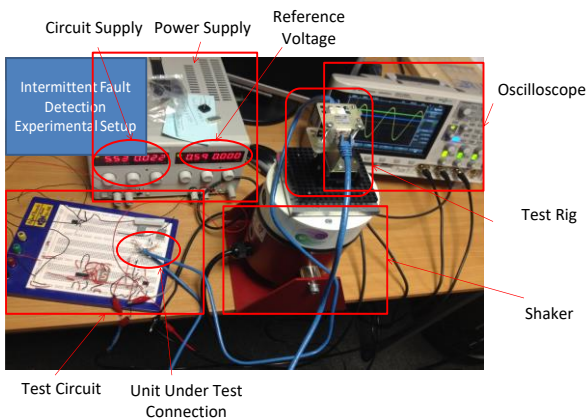

Figure 4.12. Experimental Setup for Intermittent Fault Detection

This oscilloscope has four channels, 4 G bits/second sample rate, 200MHz bandwidth and a built-in function generator that can output a variety of signals but 550K Hz, 3v peak-to-peak sinusoidal signal as a voltage source is used to the voltage divider circuit. A dual mode power supply is used to provide supply

and threshold reference voltage to analogue and digital circuit. A TS393 CD Micropower Dual CMOS Voltage Comparator OpAmp (Operational Amplifier) is used as a voltage comparator to trigger the input signal. The divider circuit consists of two $1\text{k}\Omega$ resistances. The 1N4148 diode and 200pF capacitor are used to smooth the output of the test connection/channel for threshold monitoring. The output of a comparator is fed to a CMOS Decade Counter IC (Integrated Circuit) CD4026B that is used to count intermittency and to display on a 7-segment display.

4.4.2 Measurements

An intermittent fault generator circuit, i.e. RJ45 test rig is connected to an intermittent fault monitor circuit, as described in Section 3, in such a way that it connects a electronic circuit under normal operation and disconnects when there is an intermittency. The oscilloscope displays the voltage source output in yellow and the output of voltage sensing in green are shown in Figure 4.13 and Figure 4.14. These shows the voltage level when the circuit is open and closed, respectively. When the Ethernet cable is unplugged, the amplitude of the sine wave is almost 2.58 V peak to peak (V_{pp}), as shown in Figure 4.13.



Figure 4.13. Test Signal of Open Circuit

When the Ethernet cable/test rig are connected to complete a circuit, the voltage divider drops the voltage to almost 1.38Vpp, as shown in Figure 4.14. Theoretically, this should be 1.29 Vpp because it is divided by two circuits.



Figure 4.14 Test Signal for Close circuit

This variation is due to the components' tolerances. The measurements are shown in Figure 4.15 and Figure 4.16 with open and closed circuits, similarly as it has been described in simulation section. Here, Profile 1 shows the output of the open circuit while Profile 2 shows the output of the closed circuit to illustrate

an IF. The comparator's output of profile 1 shows a square wave, when there is an IF while profile 2 shows a constant amplitude because there is not any IF.

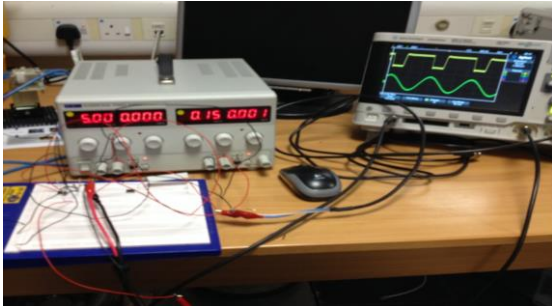

Figure 4.15. Intermittent Fault Detection Measurements - Profile 1.

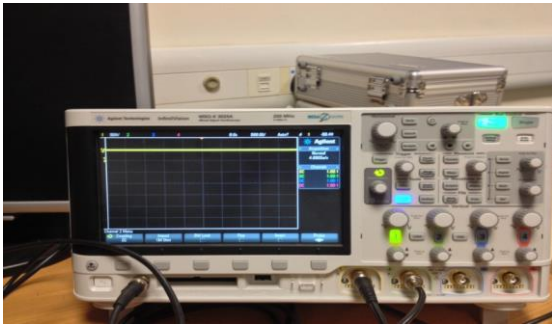

Figure 4.16. Intermittent Fault Detection Measurements, Profile 2

The overall responses of the circuit after filtering and demodulation are shown in Figure 4.17 and Figure 4.18.

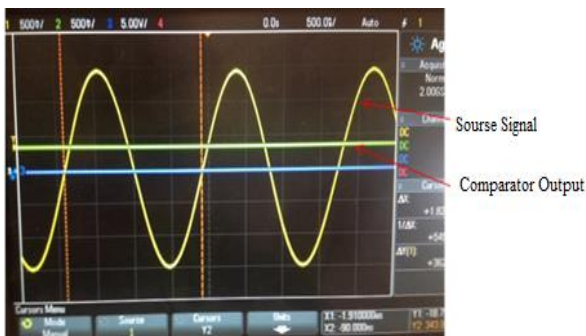

Figure 4.17. Output Profile 2.

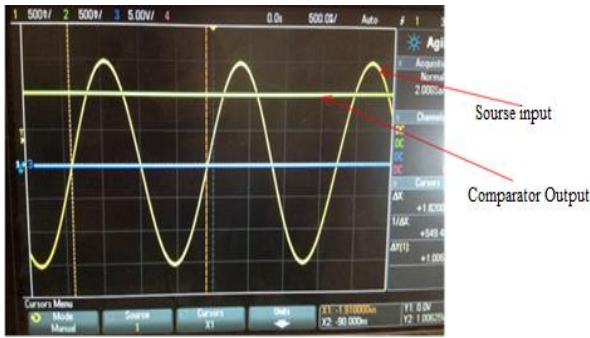

Figure 4.18. Output Profile 1

This circuit changes its transition from low to high and back to low when there is an IF. D-Flip-flop is used to capture this transition while count circuit counts number of IFs and seven segment LED show these numbers.

4.4.2.1 Comparison (Confusion Matrix)

Amplifier Input Signal (Hz)	I.F. per Second (Ladder Network)	I.F. per Second (N-Compass)	Difference between Measurements
4	3	3	0
8	5	4	+1
12	10	9	+1
16	13	14	-1
20	19	22	-3
24	23	22	+1

28	25	23	+2
32	27	35	-8
36	29	39	-10
40	30	42	-12

Table 4-1 Ladder Network Comparison with N-Compass

Error! Reference source not found. shows the measurements of IF from n-compass and ladder-network. It shows that n-compass is also measuring some harmonics of IF because its counts exceed than the mechanical vibrations of test rig. As it has described in resolution section that ladder network has embedded false alarm filtering capability by adjusting capturing time window of input signal, helped to filter the IF harmonics.

4.5 Summary

The literature review and correspondence with the industrial sector shows that 80% of NFF problems are due to intermittent faults in interconnection systems of electronic devices. This chapter has presented the fundamental problem of intermittent fault detection to overcome NFF scenarios.

It starts with the overview of NFF and describes how it behaves at different stages for a through life engineering products. It also describes communication technologies for intermittent fault detection from literature and high lights the gaps/ limitation of current technologies.

An electronic ladder network circuit for intermittent fault detection and health monitoring have been simulated and its time/frequency plots highlight that this method is useful to detect and classify an intermittent fault. It is also seen from the spectrum that an intermittent fault is like a coloured noise depends upon external vibrations. To understand the duration and frequency of intermittent faults for further investigation, this circuit uses FFT and time duration of intermittency by measuring the number of pulses and spectrum analysis. One of the advantages of this algorithm is that it could be used in-situ for health monitoring and intermittent fault detection. This could also be used to monitor the degradation of wires and connectors with minute modification using its spectrum, as degraded cable will effects the signal's bandwidth.

Verification of this novel algorithm in time domain has been implemented with an experimental setup to create repeated intermittent faults under vibration stress but this could be used for any high/low-power interconnection system. It is verified using an oscilloscope and bespoke intermittent detection equipment. It also shows that an oscilloscope is not adequate to capture intermittent faults due to lack of latching very fast transitions.

It was described that how to adjust the resolution, and to overcome false alarms. Intermittent discontinuities could be efficiently detected by AC signals of particular frequency. It is concluded that the frequency of carrier signals is very important to eliminate other noises to improve diagnostic confidence level. Another big advantage of this method is that this could be used in-situ with different frequencies other than the operational band of frequencies.

This intermittent fault diagnosis technique may not always be adequate as it indicates intermittency only when the connection resistance goes to infinity (open circuit) for very short durations. However, if the resistance goes to a high (but finite value) for a very short duration, this and the degradation of the connector will be undetectable. The Fourier analysis presented could be used to overcome this problem. Filtering techniques could also be used in future to detect intermittent faults and degradation.

4.6 Contributions

- The novel ladder network for IF detection
- Improved detection capability from existing IF detection equipment
- Simulation and validation of novel algorithm

5 COMMUNICATION TECHNOLOGIES FOR INTERMITTENT FAULT DETECTION AND FEATURE EXTRACTION

Intermittent faults are completely missed out by traditional monitoring and detection techniques due to non-stationary nature of signals. These are the incipient events of a precursor of permanent faults to come. Intermittent faults in electrical interconnection are short duration transients which could be detected by some specific techniques but these do not provide enough information to understand the root cause of it. Due to random and non-predictable nature, the intermittent faults are the most frustrating, elusive, and expensive faults to detect in interconnection system. The novel approach of the author injects a fixed frequency sinusoidal signal to electronics interconnection system that modulates intermittent fault if persist. Intermittent faults and other channel affects are computed from received signal by demodulation and spectrum analysis. This chapter describes technology for intermittent fault detection, and classification of intermittent fault, and channel characterization. It also describes the functionally tests of computational system of the proposed methods. The results demonstrate to detect and classify intermittent interconnection and noise variations due to intermittency. Monitoring the channel in-situ with low amplitude, and narrow band signal over electronics interconnection between a transmitter and a receiver provides the most effective tool for continuously watching the wire system for the random, unpredictable intermittent faults, the precursor of failure.

5.1 Introduction

The novel approach of IF detecting and characterization has been developed to overcome IFs issues and it is very different from traditional diagnostic methods. Novelty of the proposed new technique is the fact that signs of IF intrinsically modulated on a carrier signal, in compare with healthy wired communication channel and interconnection system. In healthy communication link carrier signal propagates without any changes that affect amplitude/phase/frequency of signal but only with Additive White Gaussian Noise (AWGN). The proposed technique aims to look at signature of intermittency as a modulated message on carrier, and employ demodulation techniques to explore behaviour of aged channel/interconnections.

In this new approaches it sends a sinusoidal carrier to interconnecting system and demodulate the received signal from interconnection channel for IF detection and feature extraction to find the root cause of problem. This could be used for multipoint of electrical/ electronic interconnection system and diagnose the health status of the wire after de-demodulation to retrieve an intermittent signature of channel. The essence of this approach is using communication modulation techniques to detect and electrical interconnection system. The transient caused by the intermittent fault in the wire would disrupt the signal sent over interconnection from a transmitter, and thus arriving signal at the receiver would contain intermittent signal information. When intermittent signals are found it will extract IF information by de-modulation algorithms. The features of amplitude, phase, and frequency are computed by AM (Amplitude Modulation), PM (Phase

Modulation) and FM (Frequency Modulation) demodulation schemes. The benefits of computing phase, amplitude, and frequency of IF could be used to classify intermittent signal for root cause analysis, and degradation monitor.

In the next section, communication technology is described and its devised method for detection and computation of fault's information in terms of duration, occurrence frequency, and channel noise. Then, third section describes, novel communication approach for IF detection using demodulation computations. Fourth section describes the test rig and application. Following section describes the results and validations of algorithm then last section summarized this chapter.

5.2 Communication Approach for Intermittent Fault Detection

Related to fault detection, author has used radar communication approach where it sends blank carrier signal and extras desire information from received signal. Intermittent characteristics of channel will change the propagating signal and these intermittent signatures could be computed by removing original signal. Carrier modulation / demodulation concept is being used to as sounding techniques to extract IF signature.

There are many carrier modulation schemes but fundamentally there are three modulations schemes called amplitude modulation (AM), frequency modulation (FM) and phase modulation (PM). In AM, the amplitude of carrier signal changes according to input signal and this concept is being used that if there is an intermittent open/close it changes the amplitude of carrier signal. Similarly phase

and frequency changes could be computed by using PM and FM demodulation concept.

5.3 Theory and formulation

Any AM, PM or FM signal $x(t)$ can be written as shown in equation 1

$$x(t) = R(t)\cos(\omega t + \varphi(t)) \dots (1)$$

In equation (1) $R(t)$ is the envelope of signal (amplitude of signal as function of time), ω is angular frequency, and $\varphi(t)$ is a phase of signal at t time.

For AM $\varphi(t)$, and ω are constant only envelope $R(t)$ is time variant, thus equation (1) can be written as below

$$x(t) = (C + m(t))\cos(\omega t) \dots (2)$$

In equation (2) $R(t)$ envelope is replaced to $C + m(t)$ where $m(t)$ is amplitude of base signal, in this case this is an IF signal, and " C " is carrier amplitude.

The IF signal $m(t)$ could be extracted by simple diode rectification and low or band pass filtration for analogue circuits and could be compute digital filtering / modulation algorithms. Filter band must be according to the band range of IF signal, else information of IF will be lost.

For PM and FM the amplitude envelope will remain constant but it varies the phase/frequency. For FM/PM demodulation, the signal is fed into a Phase Loop Lock (PLL) and the error signal is used as the demodulated signal.

5.4 Novel Fault Detection Algorithm

In wireless communication, to model channel behaviour they measure its properties by sending and receiving wireless signal, are called channel-sounding techniques (Molisch, 2012). Author has adapted similar method to measure intermittency in electric/electronics interconnection systems. To measure IF and its properties it sends and receives suitable signal through interconnection system. A novel algorithm has been developed to compute intermittency for IF detection and classification. Its features of amplitude, frequency, and phase are computed using AM, PM, and FM demodulation algorithms while Fast Fourier Transform (FFT) computes its spectrum. This algorithm has been shown Figure 5.1, it consists of signal source (carrier frequency), intermittent channel (test rig), demodulating unit, digital filter, IF detection using AM, FM and PM algorithms. It counts an intermittency, fault duration, and frequency of occurrence. It stores these in output buffer.

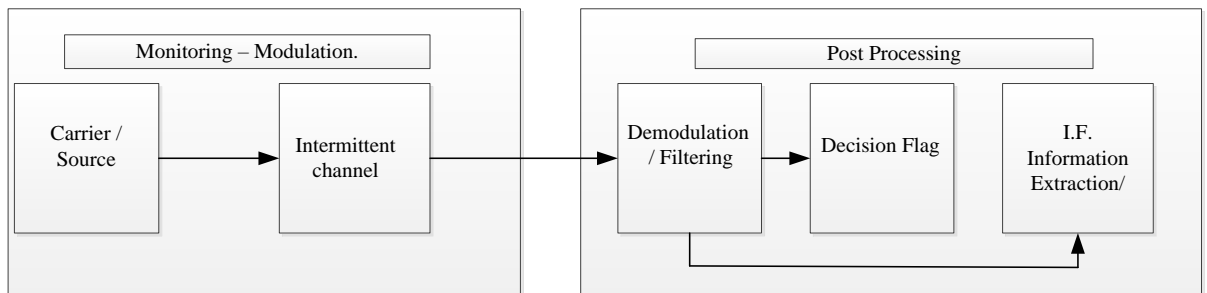
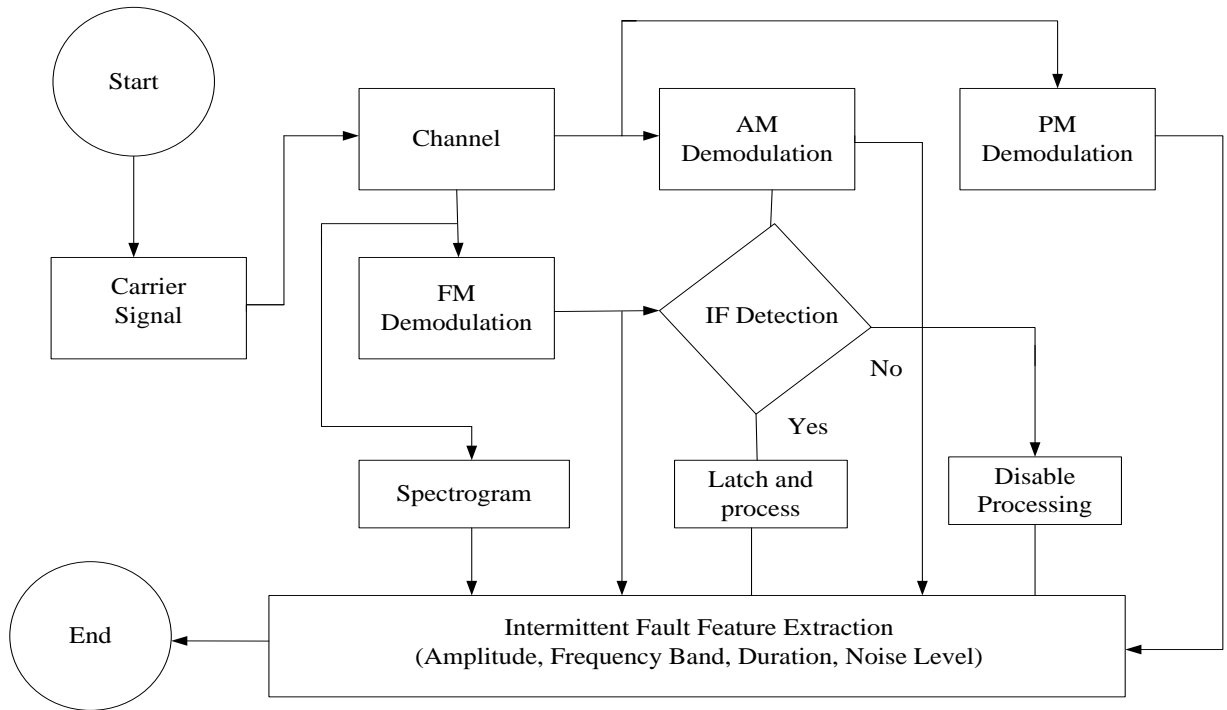

Figure 5.1. Block Diagram of IF detection Algorithm

shows the flow diagram of this algorithm. It starts with suitable selected carrier signal that fulfil the required resolution; 1 k Hz sine wave is selected to give

one millisecond resolution that is suitable for repetitively producing IFs test rig. The advantage of using one millimetre resolution is that it will eliminate debouching harmonics but if high resolution is required for less frequent IF, carrier frequency could be increased accordingly i.e. resolution is inversely proportional to carrier frequency. Carrier signal propagates through interconnection system to terminating point to complete a circuit. IF detection unit constantly process carrier signal to compute IF and dynamics. Processing unit demodulates using amplitude, frequency, and phase demodulation schemes. The spectrogram is also computed to check the bandwidth and noise level. Frequency, amplitude and bandwidth information are used to detect IF. To make IF detection decision AM and FM demodulation techniques are used, if there is not any IF then it will disable the feature extraction and memory but if IF is detected it latches the signal and extracts its feature. This also saves computation power and memory. It also computes the amplitude, bandwidth, noise level, and time information of signal when decision flag is on.



5.2 Intermittent Fault Detection Algorithm

5.5 Application & Case Study

RJ45 Ethernet socket with Ethernet cable/plug under external vibration is used to generate intermittency in the connection. A Female RJ45 Ethernet socket is used to hold it with assembly on shaker that Connector can vibrate as shown in Figure 5.3.

The grid has been installed on the shaker by screws and a metal plate as shown in this figure. This Ethernet connection assembly is used to produce multipoint intermittent fault under vibration.

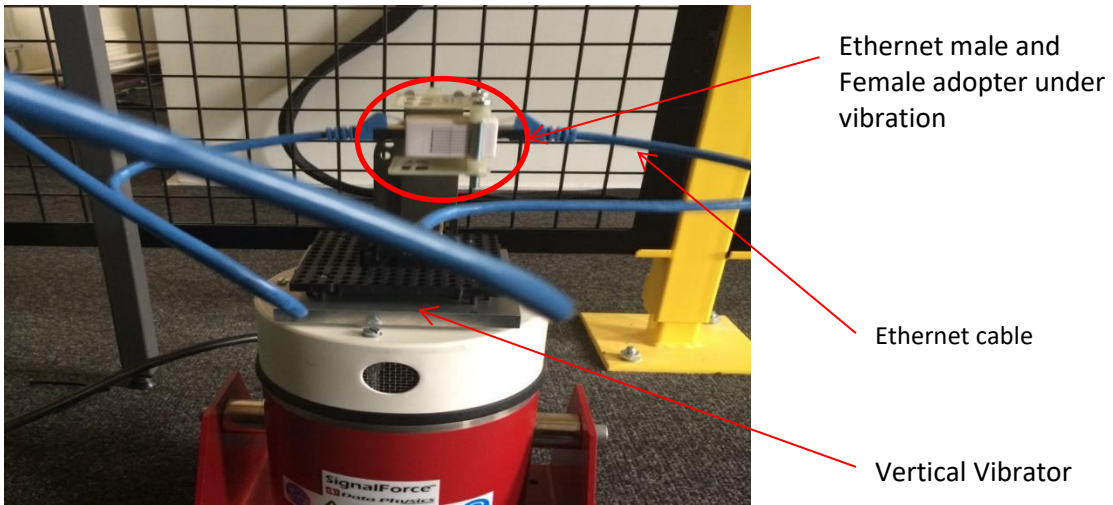

Figure 5.3. Ethernet Male and Female Socket with Cable Connection as an Intermittent Test Rig

Other ends of Ethernet cable are connected to a circuit and data acquisition system. A complete circuit setup is shown in Figure 5.4. It consists of a test rig, oscilloscope, and data acquisition system.

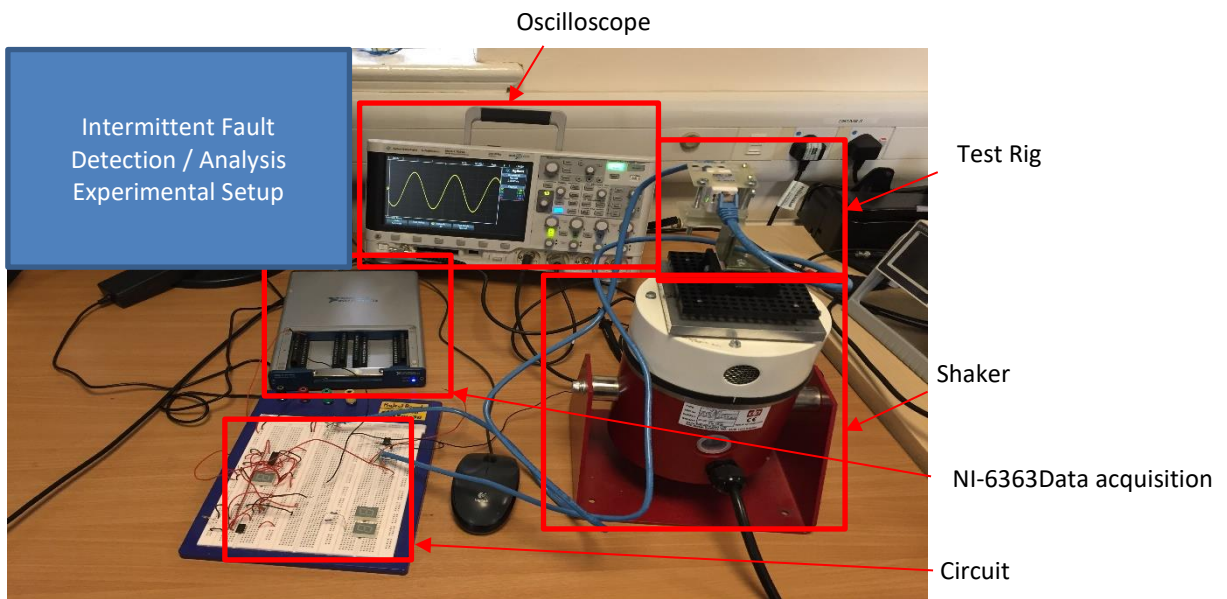

Figure 5.4 Experimental Setup for Intermittent Fault Detection

This oscilloscope has four channels, 4 G bits/second sample rate, 200MHz bandwidth and built-in function generator that can output variety of signals but 1.00K Hz 3v peak to peak sinusoidal signal is used as voltage source to voltage divider circuit. The NI-6363 data acquisition card can acquire up to 2 mega samples per second.

The input sine wave of one kilo hertz is propagates through test rig to receiver. To detect an IF and other information, the data is acquired using NI data acquisition card. Received data is being processed using FFT, AM, FM and PM demodulation algorithms. The decision has been taken if there is an IF fault or not; if there is an IF then its noise level, duration and frequency is calculated for IF classification or analysis.

5.6 Simulation and Validation

The algorithm has been validated by acquiring data from above mention experimental setup and processed in matlab using algorithm described in section 2.

Input carrier signal at 1 k Hz frequency, to electronic interconnection system is shown in 5.5. This propagated through a test rig under vibration as shown in Figure 5.4

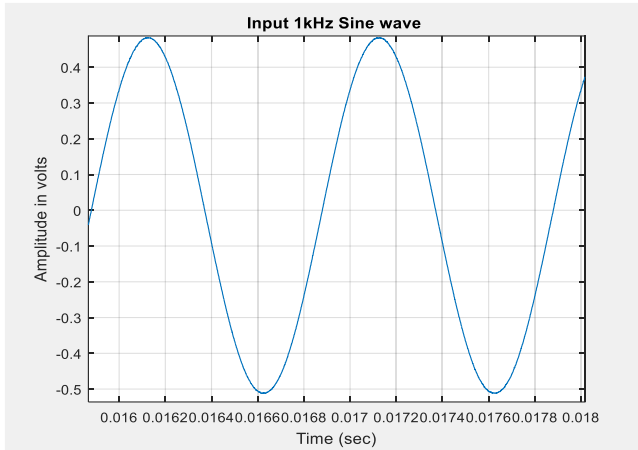

5.5 Input sine wave to unit under test

Shaking test rig adds an intermittency and other noises to a carrier signal due to loose electrical / electronic circuit. Received signal is shown in Figure 5.6. This shows that how IF effect on propagating signal. This is output of channel as shown in block diagram of Figure 5.1.

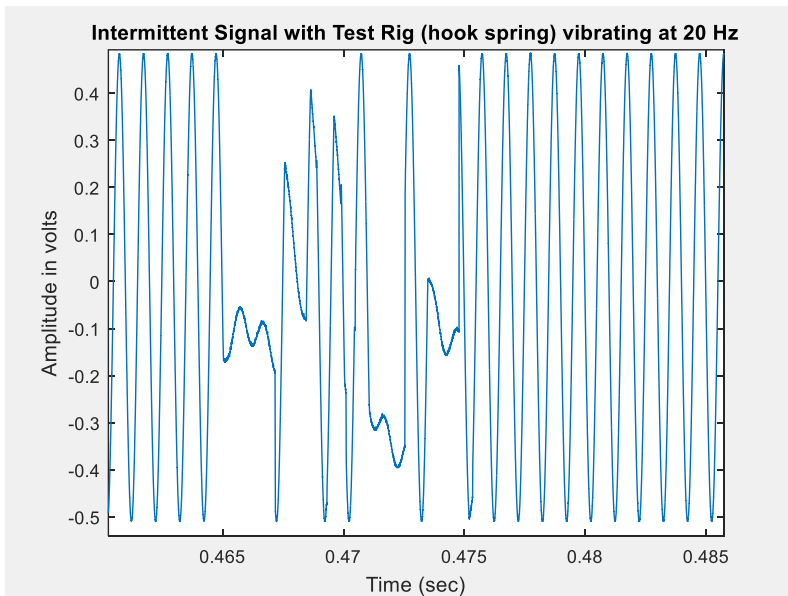

Figure 5.6 Received noisy signal with IF information.

To detect IF and to extract its feature, it has been demodulated with respect to amplitude, frequency and phase. Amplitude demodulation gives information where amplitude of signal drops due to intermittent discontinuity while change in frequency can be calculated using frequency demodulation. Intermittent fault also changes the phase of signal due to nonlinear discontinuities and could be calculated using phase demodulation.

Figure 5.7 shows AM demodulated signal that gives an intermittent signal with twenty spikes of an intermittent fault of a connection shaking at 20 Hz. The amplitude of these spikes shows the change in the amplitude with respect to carrier signal at that instant.

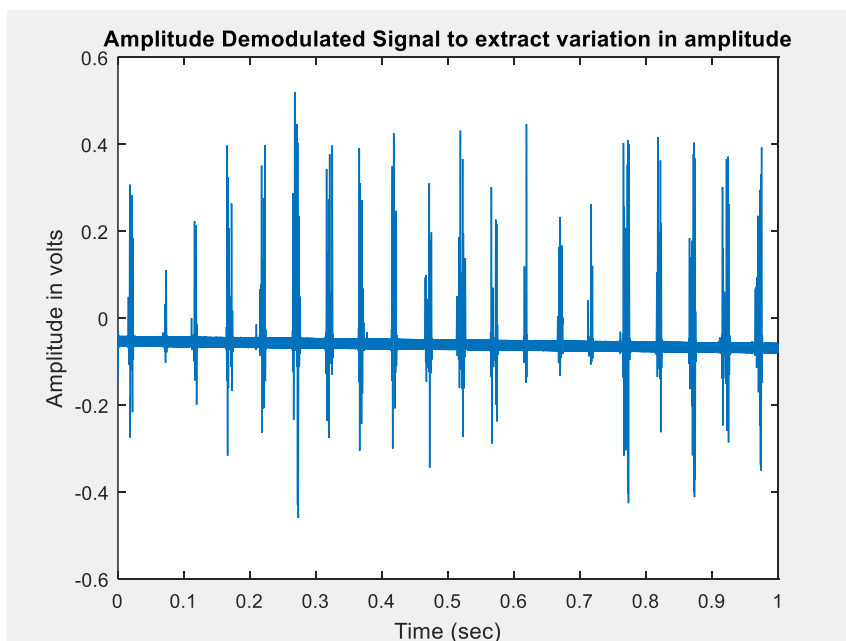

Figure 5.7 AM Demodulated Signal

Figure 5.8 shows frequency changes with respect to carrier signal. The magnitude indicates changes in the frequency at that instant. The feature of

change in frequency are used to calculate the duration of an intermittent interval by subtracting it from carrier frequency and taking inverse. The IF detection decisions are made by comparing both AM and FM demodulated signals and these are also used to calculate its duration and frequency of intermittent fault. It only enable processing unit then there is an intermittent interval as shown in flow diagram in Figure 5.2.

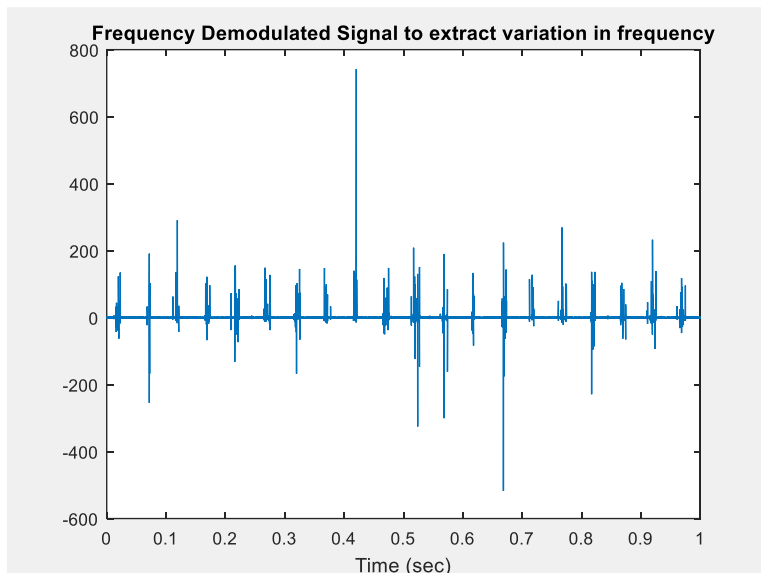

Figure 5.8 Frequency Demodulated Signal with 20 Hz Shaking Connector

The phase change is calculated by phase demodulation as shown in Figure 5.9. It gives information that how phase of intermittent signal has changed. This could be used to study that how an IF effect the signal and change the phase of transmission and adds noise to signal.

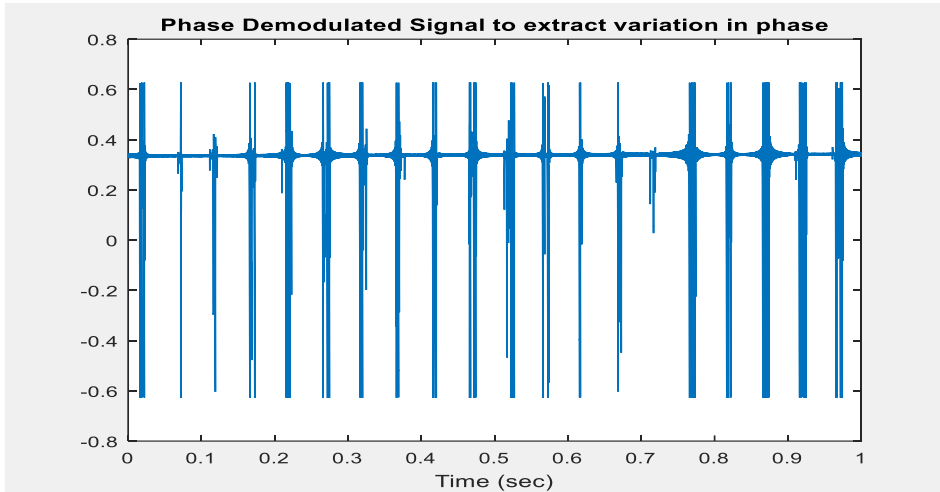

Figure 5.9 Phase Demodulated Signal with shaking 20 Hz External Vibration to a connector

In next paragraph power spectrum signal are extracted for health monitoring of interconnections system.

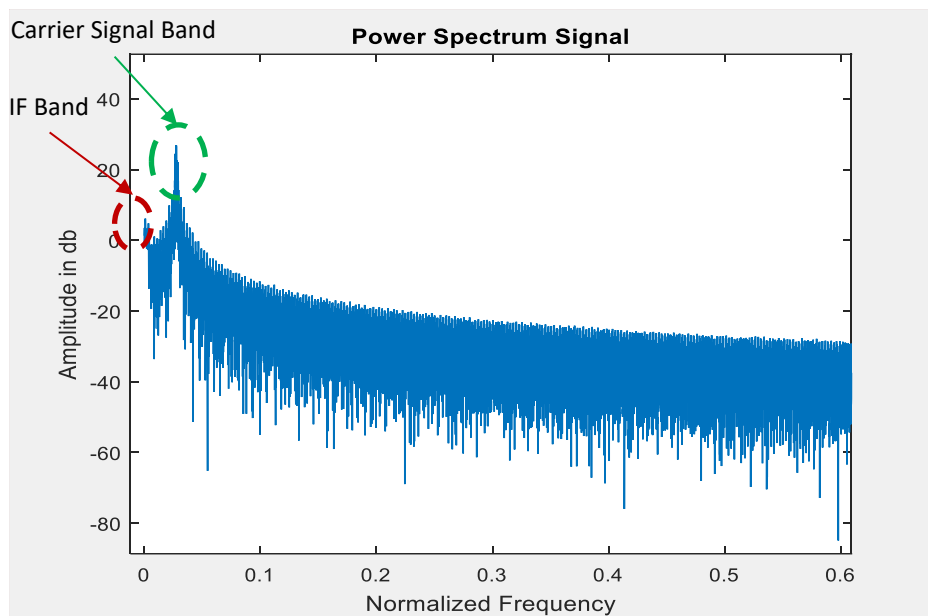

Figure 5.10. Spectrum of Intermittent signal

Power spectrum of IF signal is shown in Figure 5.10 . The channel carrier frequency and modulated intermittent signals are shown in this figure. In this figure normalized frequency has peaks at 10 db and 30 db; these corresponds to 20 and 1000 Hz frequencies and samples at 20k sample/second .Normalized frequency is f/f_s , where f is frequency of signal and f_s is sampling frequency. This spectrum shows the power of its components. It could be seen that there are intermittent signals on or around 20 Hz. This intermittent frequency is linked with the eternal vibrating shaker and this information is very important to find the root cause of intermittency. This is very useful information and is not present in any existing equipment. This IF frequency gathering at one point is very meaning full and it is correlated to external vibration that tells us the cause of vibration. If this is spread over and not gathered at one point then it be indication of moisture or heating otr something else. It could be correlated to system under-test environmental conditions as faultfinder could have prior knowledge of it.

The algorithm described in section 3 has been verified and it gives IF detection and its features with the help of traditional modulation schemes and spectrum analysis. This is the advancement of previous ladder network. In this experiment IF correlates with external vibration of shaking lose connection and its statics are given in next sub-section.

5.6.1 Experimental statistics

Amplifier Input Signal (Hz)	I.F. per Second (Ladder Network)	Phase/ Amplitude demodulated	Variation (Magnitude of IF signal) %Amplitude/Phase variation with respect to carrier Signal of 20kHz
4	3	3	40
8	5	7	83
12	10	13	46
16	13	17	39
20	19	20	92
24	23	24	81
28	25	26	64
32	27	30	56
36	29	34	66
40	30	36	68

Table 5-1 Ladder Network Comparison

Table 5-1 shows the measurements experimental statistics of Amplitude / phase modulated ladder-network. Phase and amplitude variation of intermittent fault signal were extracted by de-modulation with respect to phase and amplitude. This information is displayed as percentage. This information with fault count gives the more confidence level. If this data combined with spectrum or frequency modulation could help to investigate the root cause of fault. It means that if IF is due to vibration or ageing or humidity. The added features could be included for future IF fault finding equipment to find the root cause.

5.7 Summary and Contributions

Fundamental modulation schemes are used in ladder network for IF detection in this chapter. It started with fundamental issue of NFF and describes the drawbacks of existing techniques. It also describes fundament of classical communication and tells how it could be used in-situ for intermittency diagnosis. It highlights that intermittent signal can be extracted using communication demodulation schemes and could also be classified with respect to spectrum of intermittency and that could be linked with external vibration or other intermittency causes. It describes the algorithm and experimental that validates it and some statistics. This algorithm also gives IF signal's characteristics with respect to amplitude, frequency, and phase variation that could be used to understand its effects on the system performance.

The main contributions are highlighted below

- Modulation / demodulation techniques could be applied in-situ.
- It filters other noise by selecting carrier signal, so no need for external filters.
- Information of phase – amplitude variation adds to confidence of IF detection.

6 DIRECT SEQUENCE SPREAD SPECTRUM FOR MULTIPOINT INTERMITTENT FAULT DETECTION

As products like trains, planes, and cars become more complex in functionalities, requiring greater electronic and mechanical design complexity also shrinking in size, packaging and electronics assemblies are becoming more tightly integrated than ever with increased number of interconnections. This requires multi-node diagnostic equipment for both consistent and intermittent faults.

Single point novel Intermittent faults (IF) detection techniques have been described in previous chapters. A novel Direct Sequence Spread Spectrum (DS-SS) technique has been conserved for multipoint IF detection and health monitoring. It uses channel sounding technique to get interconnection system's impulse response. This is extension of basic ladder network that has been illustrated in chapter 4. In this chapter impulse response is used to get signature of intermittency rather than frequency or spectrum.

Next section describes introduction and overall structure of this chapter.

6.1 Introduction

In theory electronic circuits should not wear-out but due to external stresses like vibration and humidity cause detrition to electrical/electronic interconnecting system in automobile and transport industry. If these are not detected on time or at the early stage, it would gradually lead to permanent fault and are also safety critical (Correcher, et al., 2012). This also leads to many other problems for

example delayed or cancellation of flights, electrical arc or spark that could lead disaster that progressed from IFs.

Manufacturing imperfections, poor design and system degradations are main causes of intermittent faults. Although Sheng et al are disagree that intermittent faults are precursor of permanent failure (Sheng, et al., August 2014) but S. Bryan et al says that intermittent faults are precursor of hard failure (Bryan, et al., 2008). These both statements could be true, depends upon causes of intermittency. IF due to system/component degradation are precursor of permanent faults but marginal design or manufacturing imperfection are not signs of hard failure. Irrespective of causes; IFs are random and non-reproducible incidents, and are most frustrating, elusive, and expensive faults to detect and locate in wiring / interconnection systems.

IFs are identified by visual or traditional instruments for electronic/electrical interconnects. It has also been reported that conventional test equipment, which is required to carry out the fault investigation, are not always successful. This can be due to the fact that the necessary levels of confidence and efficiency are inappropriate in the many industries which are suffering No Fault Found (NFF) failures. If testability as a design characteristic was successful, perhaps NFF would not be so problematic. This is particularly evident in the case of attempting to detect and isolate intermittent faults at a test station. The ability to test for short duration non-stationary IFs using conventional methods are not suitable due to nature of IF, so it will almost certainly result in a NFF. The one major issue with

designing component testability is that the focus is on functionality and integrity of the system at the ATE is not tested [6].

There is many test equipment those are used to detected anomalies in electrical parameters and temperature profiles. The more common ones include multi-meters that detect steady or time invariant signals. On the other hand, digital oscilloscopes are used for rapid changes based on the sampling function. Problem with an intermittent fault is that it occurs for only a short duration, making it difficult to detect unless a very high sample rate that is least few hundred's time greater than IF transition. This goes beyond the capabilities of typical test equipment. The current state-of the-art in intermittent fault detection during maintenance testing includes latching continuity testing, analogue neural network technology and time domain reflectometry.

There are various disadvantages of these techniques: to halt operation for inspection, hard to capture or watch on oscilloscope or voltmeter as well as ineffectiveness due to many inspection points and some time being in the location frequently hard to reach or observe. These are unable to detect the fault in many cases since the duration of the fault was often short and not consistent. System would behave normally and it would find the interconnection/wire system normal or NFF status. Therefore, it is easy for the observer or instrument to miss the occurrence of intermittent fault.

Much research has been done on reflectometry wiring fault detection and that is used for high power electrical wirings and could not be used for interfaces and

lose solder joints or for other electronics circuits. The concept of reflectometry relies on transmitting electromagnetic waves across the wire and observes the reflections. These reflections depend upon the variation of impedance in the wire system as $\frac{Z_1 - Z_2}{Z_1 + Z_2}$, where Z_1 and Z_2 are impedances of two electrical mediums. Time between the incident and the reflected wave is used to locate the fault. Magnitude of reflections is used to determine if it is a potential fault or not. These techniques have drawbacks for modern electronics / electrical system that any change in the wire material (e.g., connection in circuit) reflects the incident waves resulting in erroneous fault determination. These techniques usually require high voltage pulses.

Recently, direct-sequence spread-spectrum (DS-SS) modulated signals are used instead of high voltage signals employing digital signal processing techniques to find and locate electrical faults (Smith, et al., 2005). This technique works on reflectometry, and it solves the need to use low voltage signal that does not interfere with online signals and could be used in-situ, but still there is a problem of reflection occurring at all points of interconnections in the circuit. So this technique is not suitable to use for electronic circuits i.e. for PCBs, solder joints, interfaces, and similar interconnections. Otherwise, the injected signal would be reflected from both ends and result in a combined, distorted, and reflected false signal due to impedance mismatch.

This requirement of fault detection at either end is very difficult to meet since many electrical/electronic networks are connected in a complicated format, often

in mesh architecture. There is a neural network based bespoke equipment to detect intermittent fault for multipoint in complicated mesh architecture but it could only be used for offline testing.

It also does not give the wire channel characterization or degradation information. It only detects if there is intermittent connection.

The novel approaches of IF detecting and characterization has been developed by the author to overcome above mentioned issues and it is very different from traditional diagnostic methods. Kim et-al have used DS-SS frequency shift keying (FSK) modulation techniques, carrier technologies to overcome reflectometry issue of reflections and false alarms (Kim, 20-22 April 2009). Although Kim has solved the false alarms of reflections in reflectometry but still it could not be used for mesh and complicated architecture of multipoint and does not give channel characterization or degradation information. The new approaches of the author spread DC signal with DS-SS and send into interconnection system for IF detection and channel measurement. This could be used for multipoint of electrical/ electronic interconnection system and diagnose the health status of the wire after de-spreading to retrieve an intermittent signal at output of system. The essence of this approach is using communication sounding techniques to detect and electrical interconnection system. The transient caused by the intermittent fault in the wire would disrupt the DS-SS signal sent over interconnection from a transmitter, and thus the DS-SS signal arriving at the receiver would contain intermittent signal information. When intermittent signals are found it will extract intermittent fault information by de-spreading i.e. multiplying it with PN-code. Only

same PN-code will de-spread the signal which has been used for spreading, each node will have unique PN-codes.

In the next section, communication technology and its invented method is described for detection and extraction of faults information in terms of duration and occurrence frequency, and channel impulse response for characterisation if wire channels.

This chapter describes communication approach for IF using DS-SS signal technology devised for IF, transmitter and receiver configurations. Then, section III describes, first simulation structure of the prototype system developed and, later, the simulation performed using the prototype system and the results obtained from it.

6.2 Communication Sounding Approach for Intermittent Fault Detection

Taylor and Faulkner proposed direct-sequence spread spectrum modulation on power line carrier, and outlined optimal signal processing techniques and frequency domain correlation techniques for the on-line test in high voltage line (Kim, 20-22 April 2009). Lately, slightly different use of spread spectrum was reported from the research result of on detecting live wire problems (Cynthia, et al., 2005). The novel approach of DS-SS fault detection comes from the idea that, unpredictable intermittent would be detected, if detectable, only when it is active, there should be a something continuously on the interconnection system that can be influenced by any event on the wire. The propose approach applies as the

"something" DS-SS signal, populates the wire system under observation and all the time ready to carry intermittent event to end. The impulse response of interconnection system could be calculated by de-spreading and dividing by input signal, to see intermittent event or channel characteristics like degradation that are not extract-able in traditional equipment like oscilloscope, reflectometry, Neural network based bespoke equipment or voltmeter.

System impulse response is used to get frequency response of system. This is used in many applications and most electronics system is designed with the consideration of transfer function or impulse response. This is also used to get channel response to see behaviour of channel over frequencies of interests for reliable communication. This concept is being used to get frequency response of wire or of other interconnection system, and these techniques are known as channel sounding techniques.

The impulse response will give the channel response over wide range of frequencies. Any crack or degradation could be detected by impulse response. Small wire degradation might not affect DC or low frequencies but higher bandwidth response can be used to estimate wiring and interconnection system.

In time domain, the channel can be described as complex impulse response $h(t, \tau)$ as show in Figure 6.1

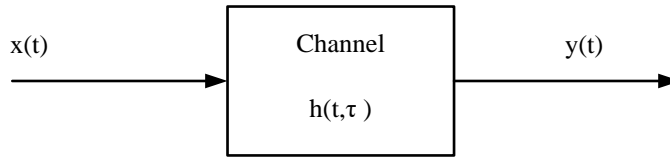

Figure 6.1. Channel Impulse Response

$$y(t) = h(t, \tau) * x(t) \dots \dots \dots (2)$$

Equation (4) shows relationship between input and output of channel. In this equation $x(t)$, $y(t)$ are input / output, and impulse response $h(t, \tau)$ with "*" convolution symbol. To de-convolve $x(t)$ from $y(t)$ in time domain is bit complicated but this could also be express in frequency domain as

$$Y(f) = H(f).X(f) \dots \dots \dots (3)$$

$$H(f) = Y(f)/X(f) \dots \dots \dots (4)$$

In equation (5) and (6) $X(f)$, $Y(f)$ are Fourier transforms of $x(t)$ and $y(t)$. $H(f)$ can be computed by division as shown in equation (6).

It is more convenient to calculate impulse response / transfer function for discrete time signal using z transforms. $X(z)$ transfer can be defined as

$$X(z) = \sum_{n=0}^{\infty} x(n)z^{-n} \dots \dots \dots (5)$$

Where $X(z)$ is z-transform of $x(n)$, and transfer function $H(z)$

$$H(z) = \frac{Y(z)}{X(z)} = \frac{y_0+y_1z^{-1}+\dots+y_{n-1}z^{-(n-1)}+y_nz^{-n}}{x_0+x_1z^{-1}+\dots+x_{n-1}z^{-(n-1)}+x_nz^{-n}} \dots \dots \dots (6)$$

6.3 Orthogonal codes

A pseudo noise code (PN code) or pseudo random noise code (PRN code) has a similar spectrum to random noise but it is deterministically generated. There most commonly used sequences in direct-sequence spread spectrum systems are Gold codes, Kasami codes, Barker codes, and Hadamard codes (GPS.GOV., 2011).

PN codes are generated by using shift registers with modulo 2 arithmetic as show in Figure 6.2. In this figure XOR logic gate is used with filp-flop (FF) 7 and FF8 as input to eight FF registers to generate the PN code.

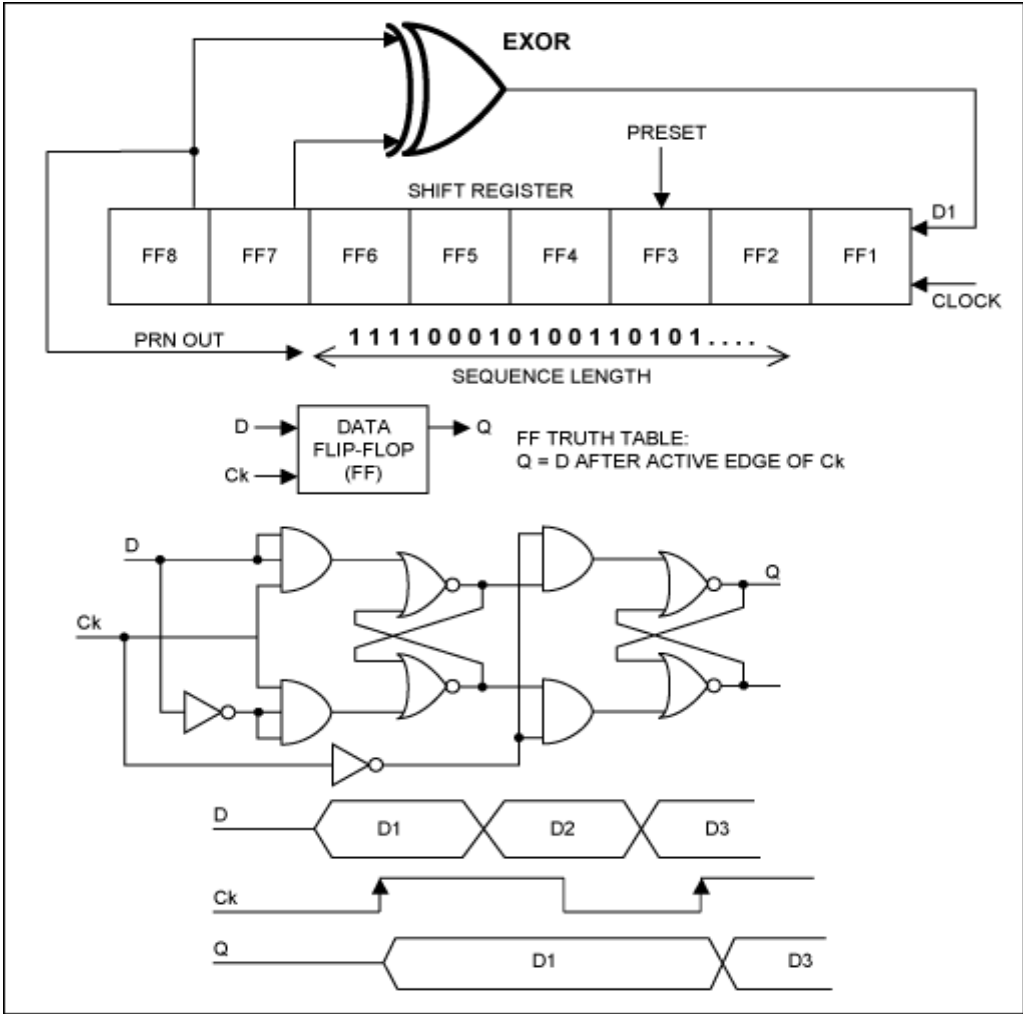

Figure 6.2. PN Code Generation

Typically, DS-SS communication system is being shown in figure xx. It demonstrates how PN codes are used to generate DS-SS signal that look like noise.

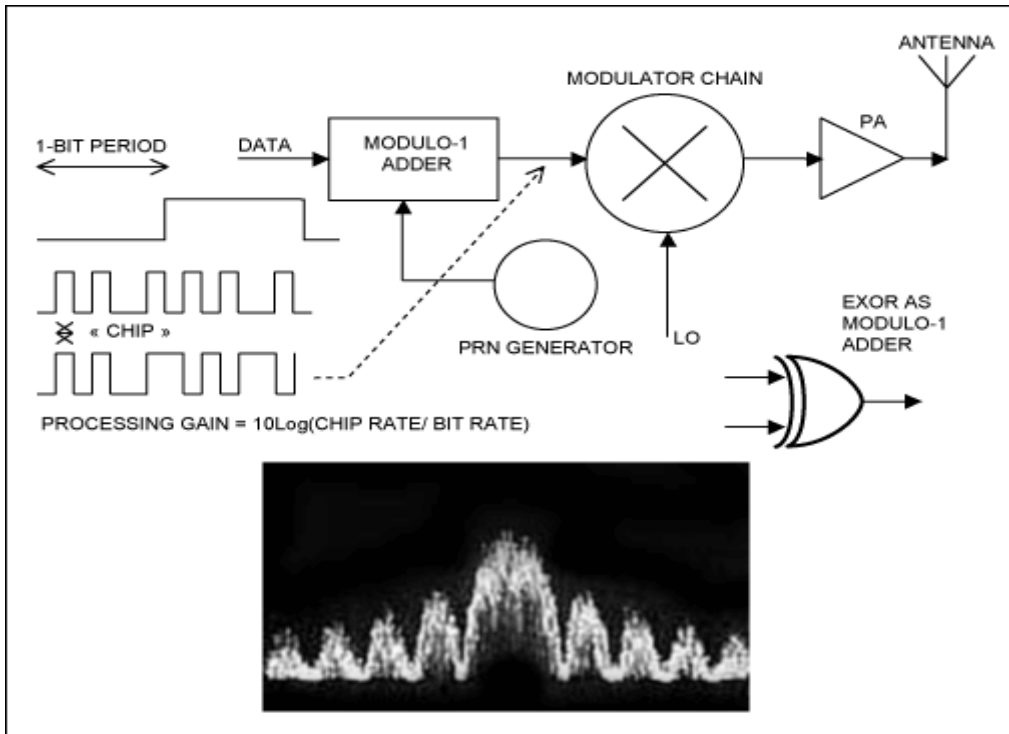

Figure 6.3. Typical DS-SS Communication System

Hadamard PN codes are perfectly orthogonal and are optimum codes to annul disturbance among users in the same base station and terminals. To obtain orthogonality, one method is to select them from the rows or columns of a Hadamard matrix. A Hadamard matrix is $2^k \times 2^k$ square matrix of elements belong to (1,-1) set. The easiest matrix is of 2 orthogonal Walsh-Hadamard sequences and that is

$$H_{(2)} = \begin{bmatrix} 1 & 1 \\ 1 & -1 \end{bmatrix} \quad (7)$$

The PN of user one is the first column, i.e., (1, 1), the PN of user two is the second column, i.e., (1, -1). Clearly (1, 1) is orthogonal to (1, -1). This concept of matrix

can be stretched recursively. For example, if 2^n users, the matrix could be found from the PN matrix for $2^{(n-1)}$ users, according to following equation

$$H_{2N} = \begin{bmatrix} H_N & H_N \\ H_N & -H_N \end{bmatrix} \dots\dots\dots(8)$$

The Hadamard Code Generator block generates a matrix, whose rows are form an orthogonal set of PN codes. These orthogonal PN codes are used for spreading in modern communication systems. In these DSSS system the receiver is perfectly synchronized with the transmitter. This makes the de-spreading ideal because DSSS codes are de-correlated completely.

The Hadamard orthogonal codes are the each single row of a Hadamard matrix. Hadamard matrices are square matrices whose entities are +1 or -1, and whose rows and columns are mutually orthogonal. Let if "N" is a positive power of 2, then N-by-N Hadamard matrix, denoted H_N , can be defined recursively as follows.

$$H_{2N} = \begin{bmatrix} H_N & H_N \\ H_N & -H_N \end{bmatrix} \dots\dots\dots(9)$$

N/N Hadamard matrix has the property that

$$H_N H_N^T = N I_N \dots\dots\dots(10)$$

where I_N is the N-by-N identity matrix.

The Hadamard Code Generator block outputs a row of H_N . This output is bipolar. One can specify the length of the code N by Code length argument. This Code length should

be the 2's power. To specify the index of row of Hadamard matrix, that is an integer of the range of [0, 1, ..., N-1], by code index argument.

6.4 Direct Sequence Spread Spectrum Sounding Technique for Multipoint Intermittent Fault Detection

Direct Sequence Spread Spectrum (DS-SS) is used as sounding technique for intermittent fault detection in multi-points electronic interconnection system. It sends a DC constant signal of "1s" as known input and it spreads with pseudo-random noise (PN), orthogonal codes to wider band. Hadamard orthogonal sequence is used for spreading in these systems because receiver is perfectly synchronized with the transmitter. In these systems, the de-spreading operation is ideal, as the codes are de-correlated completely. De-spreading completely removes the PN generated by PN codes. As input to diagnosing system is a constant DC signal thus output from this system will be a transfer function and it gives us channel impulse response by using channel sounding technique. The complete system is shown in Figure 6.4

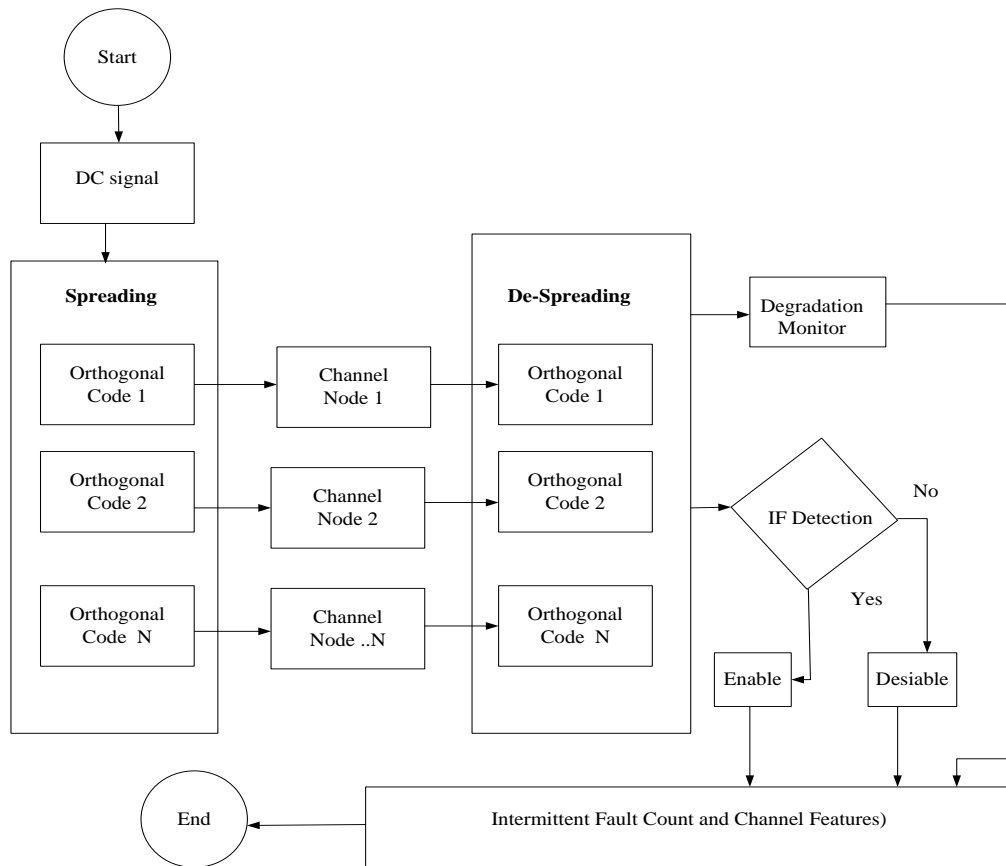

Figure 6.4. Block Diagram of Multi Node Intermittent Fault Detection using Channel Sounding

6.5 Simulation

To simulate DS-SS sounding technique for intermittent fault detection, it has been modelled in Math work's Simulink software. It could be modelled with as many test points as required but only two test points has been simulated to show how it could be used to test multi point interconnections. It consists of two transmitters, two receivers, and two test nodes of IF. In devised model Additive White Gaussian Noise (AWGN) is added to make it more realistic. It is simulated with two intermittent connection and showed how DS-SS detects IFs. It also shows

that cross talk with other point does not de-spread. This will eliminate the false alarm in multi node configuration. This model has been shown in Figure 3. This system consists of three sub blocks transmitter, channel and receiver. Each transmitter and receiver used the same orthogonal codes to spread/de-spread input signal as described in previous section. Every transmitter spreads a constant voltage signal with different Hadamard codes and propagates through an electronics interconnection system for IF detection and feature detection. Each node is provided a selectable to simulate it with and without IF. Intermittent signal is generated in matlab / simulink and connected to a two way switch which can simulate interconnection with or without IF. A white noise signals are also added to this interconnection to make it more realistic. De-spreading unit removes pseudo-noise (PN) by multiplying it with same PN code that were used to generate PN codes. This has been shown in Figure 6.5

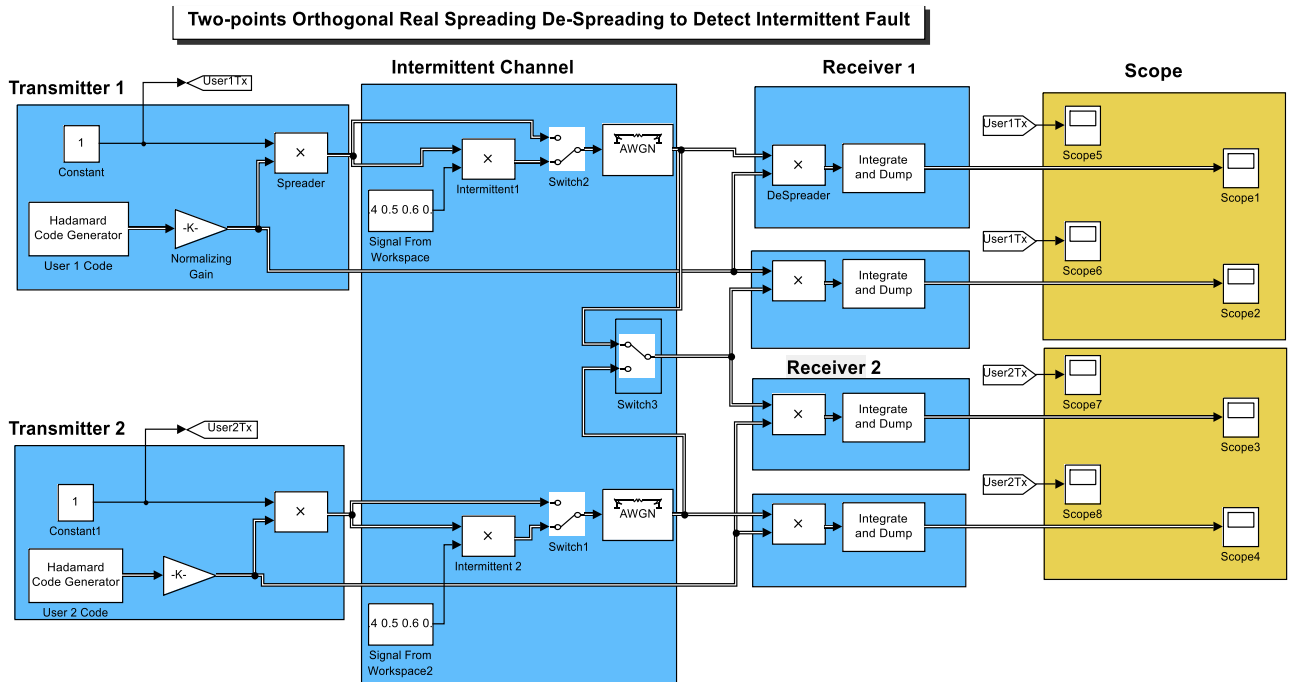

Figure 6.5. Two point Intermittent Fault Detection

6.5.1 Simulation Results

To monitor/visualise the signals at inputs/outputs, scopes from matlab / simulink library are connected to the input and output as shown in Figure 7.5. In this Figure scope 1 and 2 are connected with node one with same PN codes, while scopes 3 is connected to output with different PN code's signal than transmitter but scope 4 is connected to perfectly synchronised PN code with transmitter. A constant value input signal is connected to all inputs as shown in x4. Intermittent signals from node 1 are regenerated by removing DSSS signal; these are shown in Figure 6.7 and Figure 6.8. As scope 3 is connected to different PN code and it will not be able get intermittent signal, its noisy output is shown in Figure 6.9.

Scope 4 shows the perfectly synchronised PN code with transmitter and is shown in Figure 6.10.

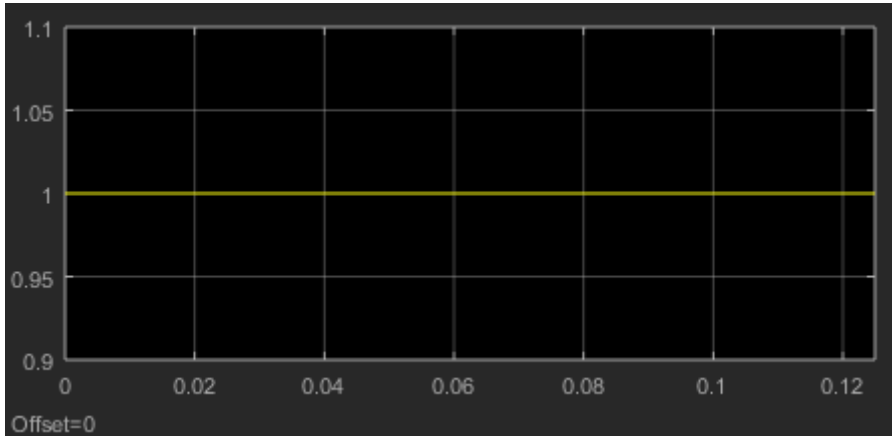

Figure 6.6. Scope 5 Shows Transmitter 1 Output before Channel

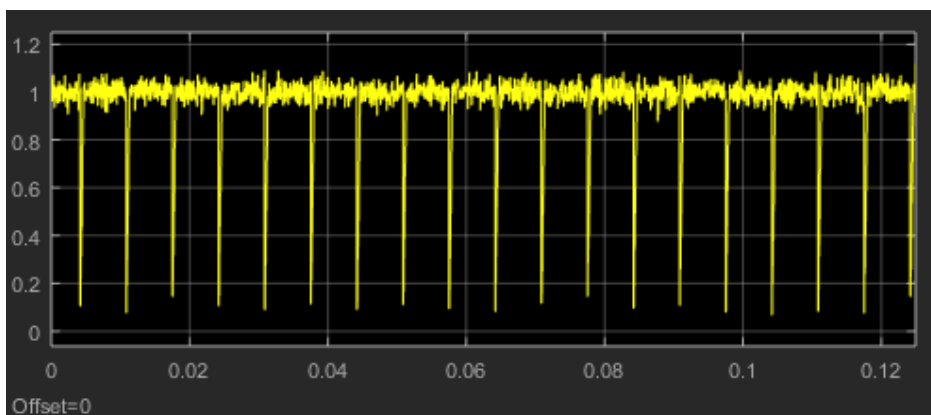

Figure 6.7. Scope 1 Shows Channel Intermittent Fault

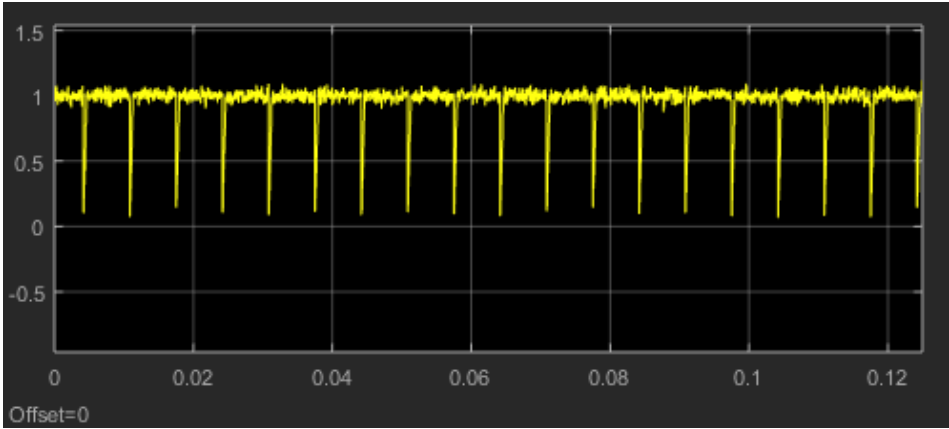

Figure 6.8. Scope 2. Shows Channel Intermittent Fault

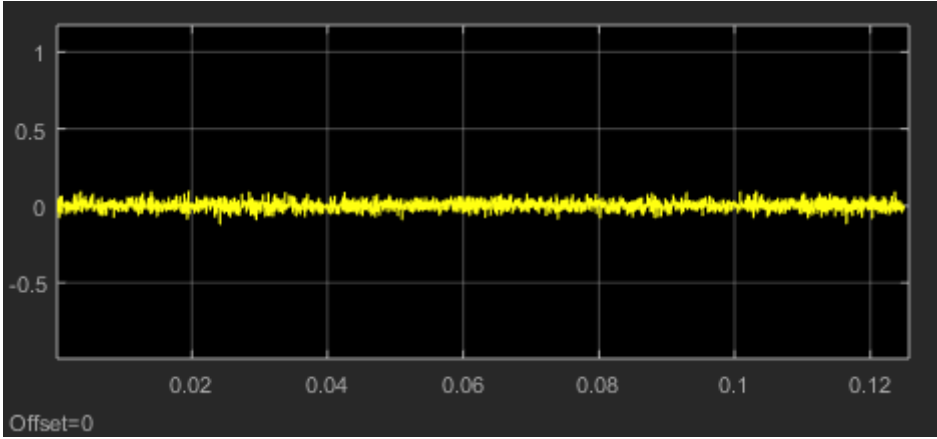

Figure 6.9. Scope 3. Shows Poor De-spreading due to wrong Orthogonal Code

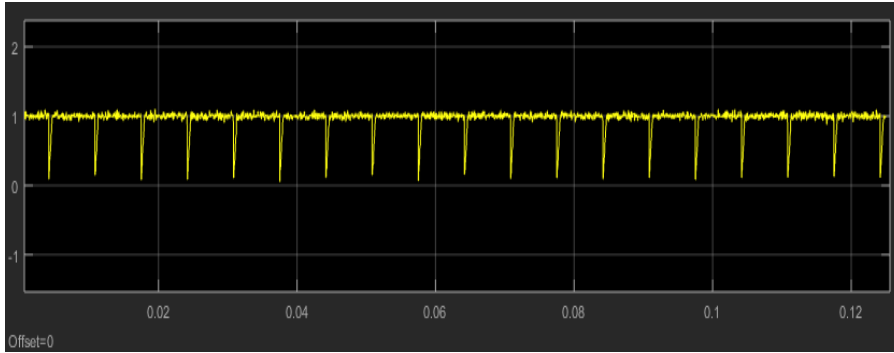

Figure 6.10. Scope 4 Shows perfectly synchronised PN code.

6.6 Validation

This algorithm has been validated by acquiring data to Simulink model from National Instrument (NI) 6363 X-series data acquisition system. This system has both analogue and digital input/outputs. Experimental setup has been shown in Figure 6.11. DSSS signals are generated in Simulink model and sent to interconnections system through NI-6363. Ethernet socket on shaker has been used as test rig, to introduce intermittency in DSSS signals. The signals are acquired back by same NI system for de-spreading and intermittent feature extraction.

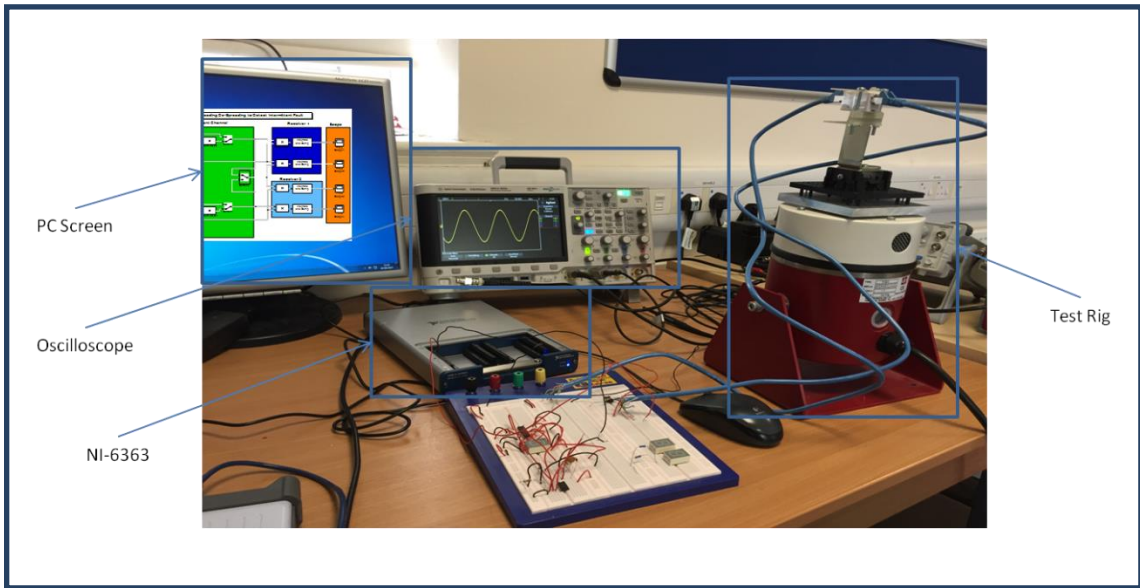

Figure 6.11 Experimental Setup

This intermittent fault detection system has been described by using a block diagram as shown in Figure 6.12. Two PN codes are used for two node IF detection. These are used to spread a DC constant of “1” Then DSSSS signals are sent to a multipoint Ethernet socket as test rig. PN codes are removed by multiplying / de-spreading to get intermittent interconnection system information as described in simulation results.

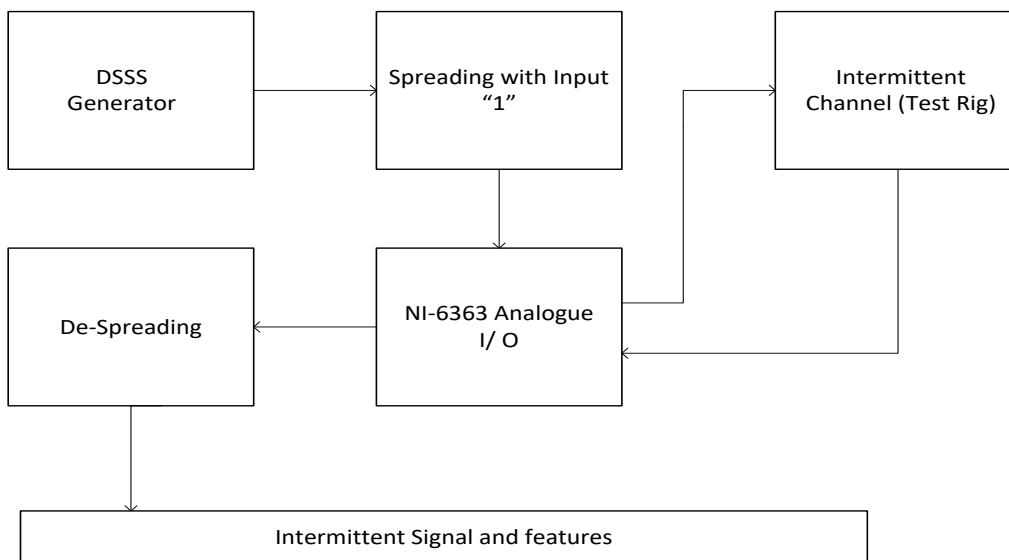

Figure 6.12. Experimental setup Block Diagram

Same Simulink model is used for this experiment as described in simulation section. Scope 1 and 2 shows the results of same interconnection loop with same PN code synchronization, whereas scope 3 and 4 shows the results of second node but with two different PN codes. In Scope 3 PN code 1 is used and it shows that if there will be different nodal code will be used it will not de-spread and output will be zero. Scope 4 shows the output of same code synchronization that were used at input.

Spread spectrum are used to pic the intermittent channel (interconnection) information as it can be seen from scope outs

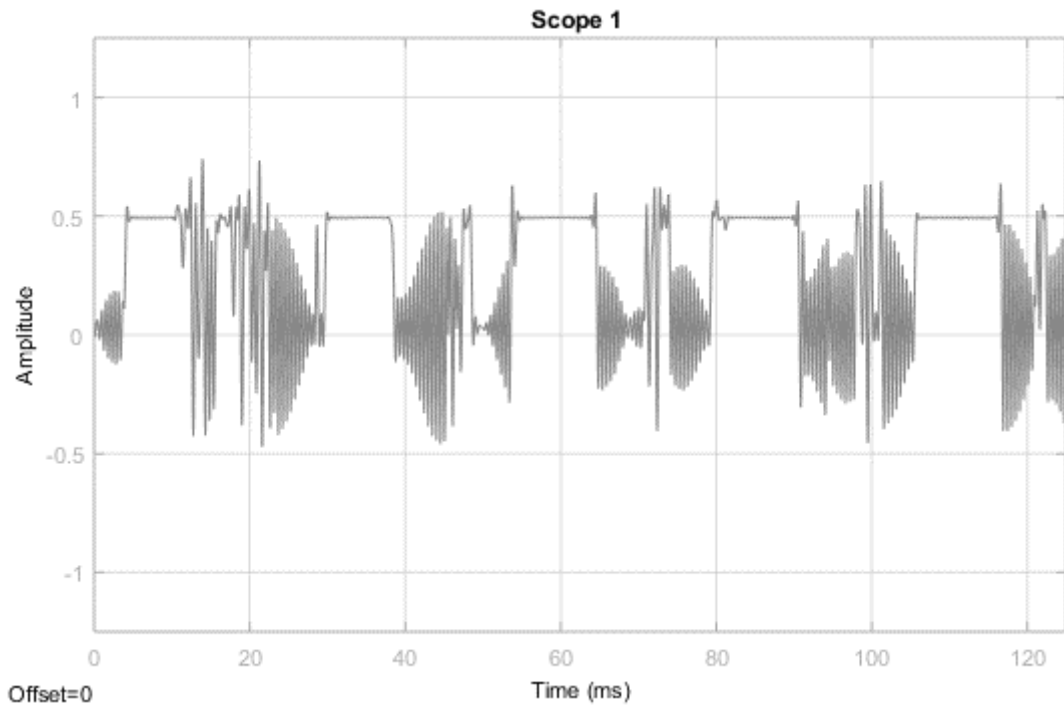

Figure 6.13. Scope 1 with same PN code De-spreading

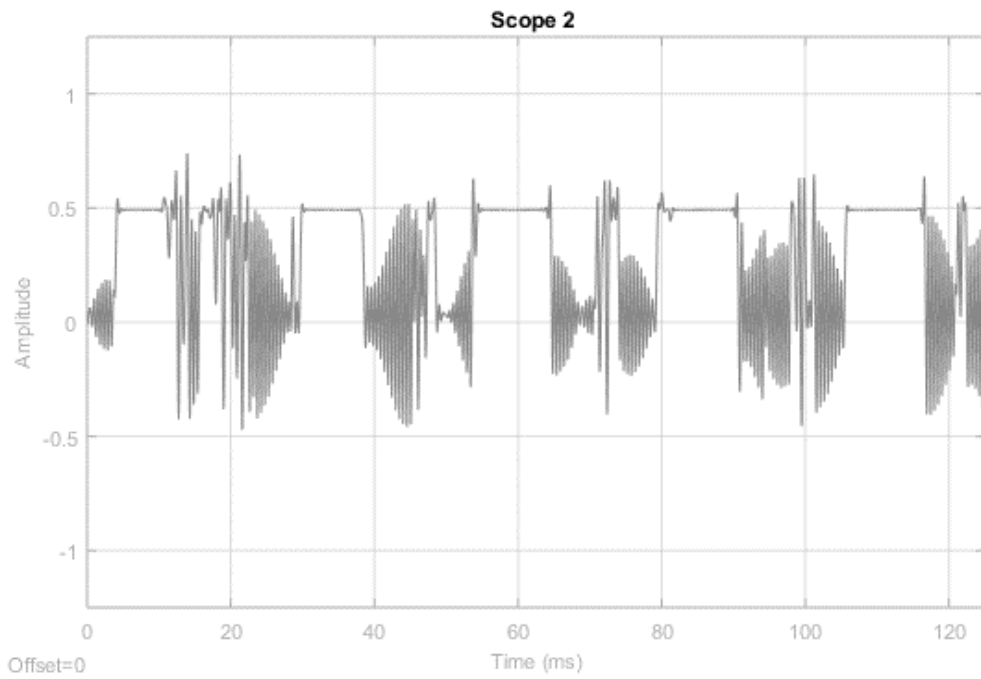

Figure 6.14. Scope 2 with same PN code De-spreading

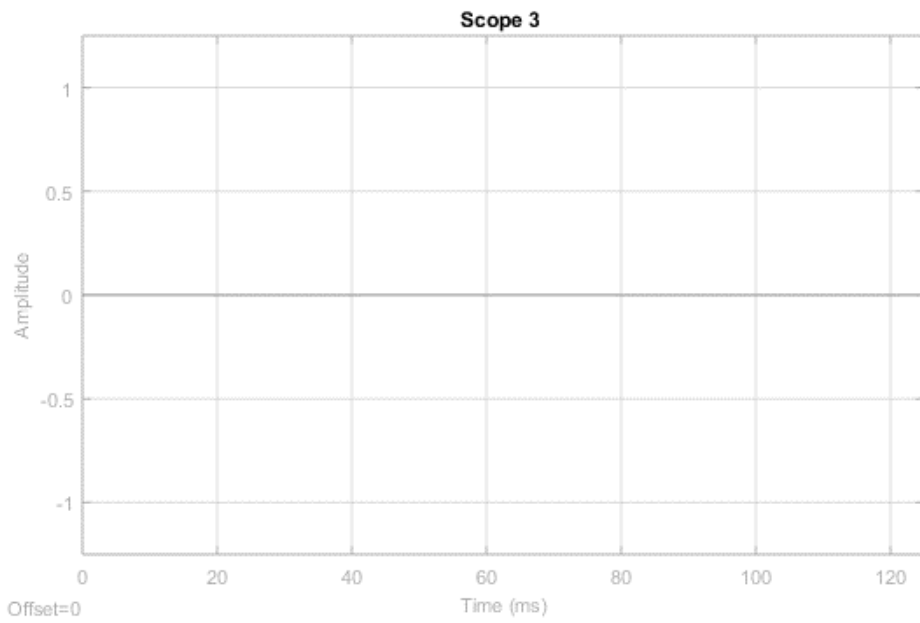

Figure 6.15. Scope 3 with Different PN code De-Spreading

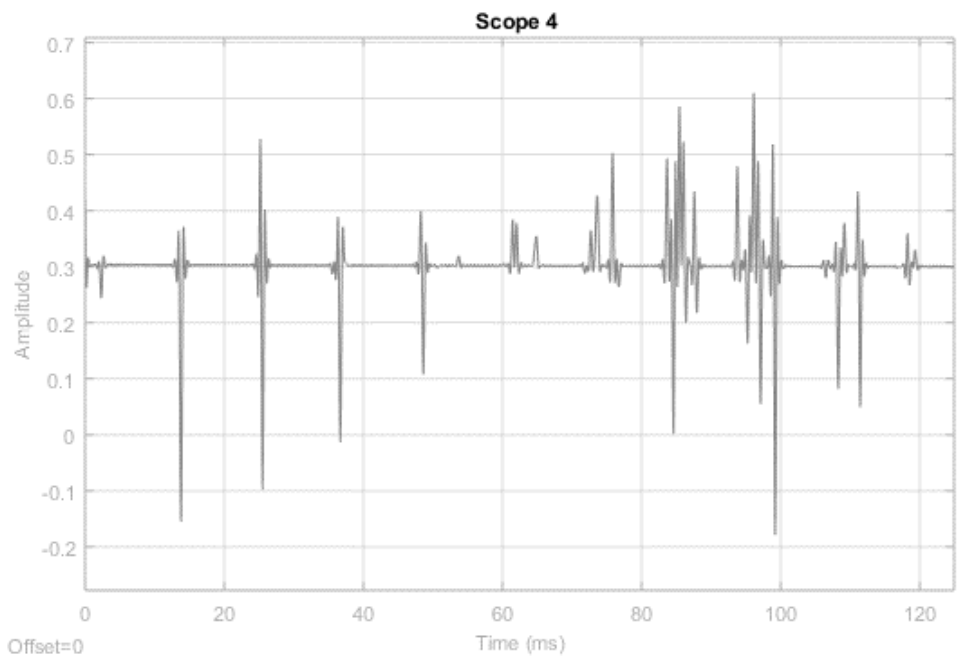

Figure 6.16. Scope 4 Node 2 with Same PN Code De-Spreading

6.1 Experimental statistics

Amplifier Input Signal (Hz)	I.F. (Advance-Ladder Network) point-1	I.F. (Advance-Ladder Network) point-2	I.F. (N-compass-) point-1	I.F. (N-compass-) point-1
4	2	2	0	0
8	5	7	3	4
12	10	11	14	10
16	13	15	17	6

20	19	20	17	22
24	23	24	8	25
28	27	26	30	20
32	30	30	37	33
36	33	34	44	33
40	30	36	38	40

Table 6-1 Advance Ladder Network statistics

Table 6.1 shows the results of experiment this shows the results from advanced ladder-network and N-compass. This shows how closely this algorithm is working for multipoint.

6.7 Summary and contributions

In this chapter DS-SS sounding techniques has been presented to get intermittent fault signatures. It starts with introduction and describes the communication theory and how it could overcome multipoint intermittent diagnosis issue that transport industry suffers.

This novel technique has been explained with matlab Simulink results to shown that wrong node will not correlate and will not give any wrong information. It calculates impulse response of interconnecting system by calculating transfer function, like channel sounding techniques Then this simulation has been validated through and experiment. Experiment setup and results highlights that

this technique could be implemented to make a fault diagnostic equipment that could be used for IF detection and feature extraction i.e. to calculate channel characteristics. This could be embedded in modern wiring system, to monitor it constantly for the status of interconnection system.

Main novelties are given below

- Multipoint with no confusion of nodes as it detects particular node itself.
- Channel characteristics from impulse response that could be used for root cause analysis.
- Spread Spectrum signal is immune to channel noise and hence reduce false alarms

7 CONCLUSIONS AND FUTURE WORK

It is concluded from the literature survey that intermittent faults are one of the major root causes of NFF. There seems to be a lack of fundamental understanding of intermittency and current technologies (that are used in electronics intermittent fault detection) are not always adequate to detect and isolate them. Due to the increasing complexity and mass production of electrical / electronic circuits the probability of intermittency is increasing, there is a need to change the way to test the wires harness and interconnecting systems as they are major factors of intermittent faults.

Also following some discussions with the partner industries it is concluded that wire harnesses and connectors play a major role in intermittent faults; that is why this research focuses on addressing the issue of electrical interconnection continuity testing, to develop the better test capabilities.

This thesis highlighted various occurrences and root causes that have resulted in NFF events while discussing the importance of diagnostic technologies. A IF test rig that can emulate intermittency in a connection was developed for experimental study and further analysis for IF detection research. The preliminary experimental results and with comparison of different fault detection equipment shows that there is a need for new techniques / algorithms that could be used for intermittent fault detection efficiently. Intermittent signal's analysis and features could be used for root cause analysis. It could also be used to predict the remaining useful life of interconnection system as IFs are precursor of wear-out or hard failure.

In order to improve diagnostic success rates, improvements need to be made to technology that have failed. There is almost certainly not one universal industrial solution. The current key areas for intermittent faults are focused around understanding test coverage represented by BIT/BITE/ATE deficiencies, development of new maintenance troubleshooting tools, techniques and concepts as well as changes to management processes. Accurate fault models, fault/events trees and system understanding, are paramount to recognise false alarms; there is a need to use intelligent health monitoring algorithms to overcome the false alarms with improved precision. Ladder networks (Neural Network for multi nodes) and other advance signal processing algorithms has been analysed for health monitoring and intermittent fault detection in this thesis.

It is concluded from fourth chapter that there is a need to develop better equipment to capture intermittent and transient faults because N-compass and pico-scope are not giving information canonical way and this cannot be used for root cause analysis. Short window frequency domain information or wavelets analysis could be used for health or degradation monitor. These also not allow us to extract features from intermittent data for root cause analysis

Next chapter has presented the fundament problem of intermittent fault and a novel ladder algorithm to detect, classify an intermittent fault for electronic interconnection system. This ladder network could be extending for multipoint to form a neural network. For only single point this novel ladder network in an electronic circuit has been emulated for intermittent detection, and health monitoring. Its time/frequency plots highlights that this method could detect IFs

quiet efficiently. It also highlights that the duration and frequency of intermittent fault are correlated with external vibrational stress. For further investigation this circuit could be used to calculate FFT and time duration of intermittency by measuring the number of pulses and Fourier analysis and it is demonstrated in the simulation results in PSpice. This algorithm could be used in-situ for health monitoring and intermittent fault detection if input signal is selected cleverly that doesn't interfere with operational signals. This could also be used to monitor the degradation of wires and connectors with minute modification by using multi-level threshold values that could indicate small signal variations.

Verification of novel algorithm in time domain has been implemented with experimental setup with vibrational test rig that produce repeated intermittency. Then it has been explained using different measurements by oscilloscope and counter circuit. To capture transients and very sharp intermittent events it also describes that how resolution could be selected to avoid false alarms. This resolution adjustment play a role as of filter to remove unwanted signals and reduce the extra filtering circuitry. It is noted that an intermittent fault of interconnection due to discontinuities could be detected efficiently by AC signal of desired frequency and threshold trigger circuit.

This intermittent fault diagnosis technique may not always be adequate as it indicates intermittency only when the connection resistance goes to infinity (open circuit) for very short duration of time. However if the resistance goes to a high (but finite value) for very short duration this and degradation of connector will be undetectable. Fourier analysis are presented in section 3 could be used to

overcome this problem or multi level impedance threshold could be used in AC to monitor degradation.

Multi-points threshold or soft values with variable frequency or frequency sweep are suggested for future work to not only detect IFs but also monitor interconnection system for its ageing. Filtering techniques could also be used in future to detect intermittent fault and degradation

Fifth chapter describes novel intermittent algorithm that uses classical communication techniques. It is demonstrated that an intermittent signal can be extracted using communication demodulation schemes and it could be classified with respect to band of intermittency that linked with external vibration by computing power spectrum of signal. This algorithm also gives IF signal's characteristics of amplitude, frequency, and phase variation that could help to understand its effects on the system performance. Power spectrum is a very useful tool and that could be used to understand the root cause of IF; in experimental work IF could be seen at 20 Hz because test rig was shaken at this frequency. Although it is not necessary that spectrum exactly relates to external vibration but could be used to understand the root cause; if it is due to vibration or due to other noise.

Further work could be carried out using filter banks to segment different possible bands of spectrum and this could be used to detect intermittency, and to find root cause.

Multipoint intermittent interconnections can be detected by using DS-SS schemes and it could be classified with respect to band of intermittency that linked with external vibration. It also reduces human factor's mistake, to put wrong node in multipoint node connection setup, for IF detection because only same PN code could only be used to extract IF information. The characteristics of IF could also be detected with respect to amplitude and frequency and these could be used to predict the interconnection ageing or manufacturing faults. This technique is low power and very efficient to use in-situ for IF detection and health monitoring. Variation monitor in amplitude, frequency, and phase are used to monitor its effects on the system performance. Classical modulation and power spectrum are very useful tool that are used for root cause analysis, as in experimental results IF could be seen at 20 Hz because test rig was shaken at this frequency. Although it is not necessary that spectrum exactly be same but it should have some relation with external vibration. This is very useful tool to understand the root causes; if it is due to vibration, or due to other noise, or ageing.

Further work could be carried out by adding wavelets banks to segment different possible bands of spectrum for further analysis of intermittent signal. This work could be carried out by wavelets transforms, or Short Time Fourier Transform (STFT); to determine the sinusoidal frequency and phase content of local sections of a signal as it changes over time and this could be used to detect intermittency, and to find root causes.

REFERENCES

Molisch, A. F., 2012. Andreas F. Molisch. In: *Wireless Communications, 2nd Edition*. s.l.:Willey, p. 884.

A. Correcher, E. G. e. a., 2010. Diagnosis of Intermittent Faults and its Dynamics. *InTech*, p. 602.

A.Lee, e. a., 1987. *Fretting Corrosion of Tin-Plated Copper Alloy*. s.l., s.n.

Abbott, W. & K.Schreiber, 1981. *Dynamic Contact Resistance of Gold Tin and Palladium Connector Interfaces During Low Amplitude Motion*. s.l., s.n.

Abbott, W., March 1984. *Time Distribution of Intermittents Versus Contact Resistance for Tin-Tin Connector Interfaces During Low Amplitude Motion*. s.l., s.n., pp. 107-111.

Abreu, R., Zoetewij, P. & Van Gemund, A., 2009. *A new bayesian approach to multiple intermittent fault diagnosis*. Pasadena, California, USA, Morgan Kaufmann Publishers, pp. 653-658.

Agrawal, S., September 2015. *Survey on Anomaly Detection using Data Mining Techniques*. Singapor, Elsevier, pp. 708-713.

Alstine, R. & Allan, G., 2005. *Demonstration and Validation of the Excited Dielectric Test Method to Detect and Locate Defects in Aircraft Wring Systems*, Washington: Aviation Research.

al, T. S. e., 1993. *Case-Based Approach to Handling Aircraft Malfunctions*. s.l., s.n., pp. 274-285.

al, Z. W. e., 2003. *Case Base Reasoning in Vehicle Fault Diagnostics*. s.l., s.n., pp. 2679-2684.

Anon., n.d. *TWI - Technical Knowledge*. [Online]
Available at: <http://www.twi-global.com/technical-knowledge/faqs/environment-faqs/faq-what-is-meant-by-a-harsh-environment-in-electronics-or-photonics/>
[Accessed 08 January 2014].

Assaf, T., 2003. *Diagnostic Expert Systems from Dynamic Fault Trees*. s.l., s.n., pp. 143-147.

B.G. Moffat, E. A. e.-a., 2008. Failure Mechanisms of Legacy Aircraft Wiring and Interconnects. *Dielectrics and Electrical Insulation; IEEE Transactions* , June, Volume 15, pp. 808-822.

Beniaminy I., J. D., 2002. *Reducing the 'no fault found' problem: contributions from expert-system methods*. Anaheim, s.n., pp. 6-2971 - 6-2973.

Beniaminy, I. & Joseph, D., 2002. *Reducing the 'No Fault Found' Problem: Contributions from Expert-System Methods*. Anaheim, s.n., pp. 6-2971 - 6-2973.

Bryan, S., Floyd, B., Nathan, O. & Brent, S., 2008. *Intermittent Fault Detection and Isolation System*. Sait Lake City, IEEE AUTOTESTCON.

C. Maul, J. a. J. S., 2001. Intermittent Phenomena in Electrical Connectors. *IEEE Transaction on Component and Packing Technologies*, September, 24(3), pp. 370-377.

C.Constantinescu, 2008. *Intermittent Faults and Effects on Reliability of Integrated Circuits*. s.l., IEEE.

C.S. Kulkarni, J. C. ., a., 2012. *Physics Based Electrolytic Capacitor Degradation Models for Prognostic Studies under Thermal Overstress*. s.l., s.n.

Chris, 1999. *Computer-Based Diagnostic System*. s.l.:Springer.

Chung, Y., 2006. A Critical Comparisn of Reflectometry for Location of wiring faults. *Smart Structures and Systems*, 2(1), pp. 25-46.

Correcher, A. et al., 2012. Intermittent Failure Dynamics Characterization. *IEEE TRANSACTIONS ON RELIABILITY*, 61(3), pp. 649-658.

Cynthia, F., Paul, S., Chet, L. & et-al, 2005. Spread Spectrum for Critical Fault Location on Live Wire Networks. *Structural Control Health Monitoring* ,Wiley InterScience, pp. 257-267.

D'Eon, P. & al, e., 2007. *Case-Based Reasoning System and Method having Fault Isolation Manual Trigger Cases*. US, Patent No. 0185854 A1.

E P Carden, P. F., 2004. Vibration Based Condition Monitoring: A Review. *Journal of Structural Health Monitoring*.

F.Loete, C., 2012. *Diagnostic of Connector's degradation level by Frequency Domain Reflectometry*. Portland, OR , s.n., pp. 1-4.

Furse, C., 2012. *Non-Contact Connections for Reflectometry and Location of Faults in Cable Shields*. Baltimore, Aircraft Airworthiness & Sustainment .

GPS.GOV., 2011. *Pseudorandom Noise (PRN) Expansion*, s.l.: s.n.

H. Qi, S. G. M. P., 2008. *No-Fault Found and Intermittent Failures in Electronic Products*.

H.Lee, S. C. e. a., 2007. *Performance of Graceful Degradation for Cache Faults*. Porto Alegre, IEEE Computer Societ, pp. 409-415.

Hamscher, W. & Klee, L. C. a. J. d., 1992. *Readings in model-based diagnosis*. San Francisco: Morgan Kaufmann Publishers Inc.

Hill, D. & Felstead, E., 1995. *Laboratory performance of spread spectrum detectors*. s.l., s.n., pp. 243 - 249 .

Hoekstra, P. a. A. D., 1974. Dielectric properties of soils at UHF and microwave frequencies. *Geophysical Research*, pp. 79:1699-1708.

Huby, G., 2012. *No Fault Found: Aerospace Survey Results*, s.l.: s.n.

Huby, G. & Cockram, J., 2010. *The system integrity approach to reducing the cost impact of 'NO Fault Found' and intermittent faults*. Cranfield Bedfordshire, Cranfield University.

IEEE, S., 2005. *Wikipedia*. [Online]
Available at: [http://en.wikipedia.org/wiki/Reliability_\(engineering\)](http://en.wikipedia.org/wiki/Reliability_(engineering))
[Accessed 08 January 2014].

J.Gracia-Moran, D. G.-T. e. a., 2010. *Searching Representative and Low Cost Fault Models for Intermittent Faults in Microcontrollers: Case Study*. s.l., 2010 International Symposium on Dependable Computing , IEEE.

J.Jones, J., 2001. Investigation of the Occurrence of: No-Faults-Found in Electronic Equipment. *Reliability, IEEE Transactions on*, 50(3), pp. 289-292.

J.K.Line, G., 2008. *Managing and Predicting Intermittent Failures Within Long Life Electronics*. Big Sky, MT , Aerospace Conference, 2008 IEEE .

J.P., H. & et, a., 2010. *HALT Evaluation of SJ BIST Technology for Electronic Prognostics*. Orlando, FL, IEE Microwave and Wireless Components Letters, Vol 11 no.3,pp.130-132,Mar 2001, pp. 978-983.

J., Z. & et, a., 1989. *Smart BIT-2: Adding Intelligence to Built-In-Test*. Dayton, OH , s.n., pp. 2035 - 2042 .

Jiang Guo, K. Z. L. S., 2012. *Fault Diagnosis System based on Dynamic Fault Tree Analysis of Power Transformer*. s.l., s.n., pp. 2679-2682.

Jyh-Ming, J. & Tripathi, V., 1992 ; current version 2002. *Time-Domain Characterization of Interconnect Discontinuities in High-Speed Circuits*. s.l., s.n., pp. 497 - 504 .

Kim, C., 20-22 April 2009. *Detection and Location of Intermittent Faults by Monitoring Carrier Signal Channel Behaviour of Electrical Interconnection System*. Baltimore, MD, s.n.

Kirkland, L., 2011. *When should intermittent failure detection routines be part of the legacy re-host TPS?*. Baltimore, MD , Autotestcon, IEEE.

Kolodner, 1993. *Case-based reasoning*. s.l.:Morgan Kaufmann Publisher.

Lala, P. K., 1997. Digital Circuit Testing and Testability. In: s.l.:s.n., pp. 14-17.

Liu, J. & Zhang, X., 2011. *Detection method of intermittent faults in electronic systems based on Markov model*. Hangzhou, China , IEEE, pp. 216-219.

M.Bushnell, V. D. A., 2000. *Essential of Electronics Testing for Digital Memory and Mixed Signal VLSI*. s.l.:Springer.

Md Thayoob, Y., Sulaiman, S. & Ariffin, A., 2010. *Analysis of Wave Propagation in Time Domain Reflectometry Circuit Simulation Model*. Kuala Lumpur , s.n., pp. 276 - 281 .

Murray, A., 2013. [Online]
Available at: <http://www.through-life-engineering-services.org/news-and-events/events/no-fault-found-seminar>

P.Lall, P. & R.Lowe, K. G., 2012 . *Leading Indicators for Prognostic Health Management of Electrical Connectors Subjected to Random Vibration*. San Diego, CA , s.n., pp. 632-638.

Paul, S., Cynthia, F. & et-al, 2005. Spread Spectrum Sensors for Critical Fault Location on Live Wires. *IEEE Sensors Journal*, June.

Qi, H., Ganesan, S. & Pecht, M., 2008. No-Fault Found and Intermittent Failures in Electronic Products. *Microelectronics Reliability Elsevier*, 48(5), pp. 663-674.

R.Isermann, 2004. *Model-Based Fault Detection and Diagnosis -Status and Applications*. St. Petersburg, Russia, s.n., pp. 71-86.

R, S. & et, a., 1988. *An Implementation and Analysis of a Concurrent Built-In_self_Test*. Tokyo, 18th Symposium on fault tolerant computing.

S Kumar, N. M. V. e. a., 2012. A Health Indicator Method for Degradation Detection of Electronic Products. *Microelectronics Reliability* , pp. 439-445.

S. Hannel, S. P. a. L., 2001. The Fretty Sliding Transition as a Criterion for Electrical Contact Performance. *Wear*, Volume 49, pp. 761-770.

S. Khan, P. P. C. H. I. J., 2012. *No Fault Found, Retest OK , Cannot Duplicate or Fault Not Found?- Towards a standardised taxonomy*. Cranfield , Bedfordshire, s.n.

S.R. Murrell, S., 1997. *Intermittence Detection in Fretting Corrosion Studies of Electrical Contacts*. Philadelphia, PA, USA , s.n., pp. 1-6.

Sheng, S., Mingqing, X., Zhao, L. & Tingting, R., August 2014. *Misunderstandings on intermittent failures and LCP-based description of intermittent failures*. Zhangjiajie , IEEE, Prognostics and System Health Management Conference .

Skinner, D., 1975 current version 2003. Intermittent Opens in Electrical Contacts Caused by Mechanically Induced Contact Motion. *Parts, Hybrids, and Packaging, IEEE Transactions on* , January, 11(1), pp. 72-76.

Smith, P., 2005. Analysis of Spread Spectrum Time Domain Reflectometry for Wire Fault Location. *IEEE SENSORS JOURNAL*, December, 5(6), pp. 1469-1478.

Smith, P., Cynthia, F. & Gunther, J., 2005. Analysis of Spread Spectrum Time Domain Reflectometry for Wire Fault Location. *IEEE SENSORS JOURNAL*, December, 5(6), pp. 1469-1478.

Smith, P. F. C. C. Y. P. P. N. K. a. L. C., 2005. Spread Spectrum Sensors for Critical Fault Location on Live Wires. *IEEE Sensors Journal*, June.

Söderholm, P., 2007. A System View of the No Fault Found (NFF) Phenomenon. *Reliability Engineering & System Safety*, 92(1), pp. 1-14.

Sorenson, B. A., 1998. *Apparatus for detecting intermittent and conductor wiring and terminations for electronic systems*. US, Patent No. 5744967.

Syed, W., Khan, S. & Philips, P., 2013. *Intermittent fault finding strategies*. s.l., s.n.

Venkatasubramanian, V. & Vedam, H., 1999. PCA-SDG based process monitoring and fault diagnosis. *CONTROL ENGINEERING PRACTICE*, pp. 903-917.

Wakil Ahmad Syed, S. P. M. S. a. I. J., 2015. A Carrier Signal Approach for Intermittent Fault Detection and Health Monitoring for Electronics Interconnections System. *IJACSA*, 6(12), pp. 144-150.

Wakil Ahmad Syed, S. P. M. S. a. I. J., 2016. A Novel Intermittent Fault Detection Algorithm and Health Monitoring for Electronic Interconnections. *IEEE TRANSACTIONS ON COMPONENTS, PACKAGING AND MANUFACTURING TECHNOLOGY*, 6(3), pp. 400 - 406 .

wikipedia, 2014. *wikipedia*. [Online]

Available at: http://en.wikipedia.org/wiki/Intermittent_fault

Y.Lei, Y. J. Z., 2013. Model Base Detection and Monitoring of the Intermittent Connections for CAN Network. *Industrial Electronics, IEEE Transactions on* , July.Issue 99.

Yaramasu, A., Cao, Y. & Liu, G., 2012. *Intermittent Wiring Fault Detection and Diagnosis for SSPC Based Aircraft Power Distribution System*. Kaohsiung, Taiwan, The 2012 IEEE/ASME International Conference on.

Zaho, J. & Lei, Y., 2012. *Modeling for Early Fault Detection of Intermittent Connections on Controller Area Networks*. Kaohsiung, Taiwan, s.n.

APPENDICES

Appendices A, B, C and D shows Matlab script , my publication list, Table of Figures and course attended during my PhD.

Appendix A Matlab Script

A.1.1 Data Acquisition

```
classdef DataAcquisitionApp < handle
```

```
% app.DataAcquisitionApp
```

```
properties
```

```
    AppPath = {'/DataAcquisition'};
```

```
    AppClass = 'DataAcquisitionApp';
```

```
    AppHandle;
```

```
    AppCount = 0;
```

```
    Increment = 1;
```

```
    Decrement = 0;
```

```
    Output;
```

```
    CurrClass;
```

```
    Version = '13a';
```

end

methods (Static)

```
function count = refcount(increment)
```

```
    mlock;
```

```
    persistent AppCount;
```

```
    if(isempty(AppCount))
```

```
        AppCount = 1;
```

```
    else
```

```
        if(increment)
```

```
            AppCount = plus(AppCount,1);
```

```
        else
```

```
            AppCount = minus(AppCount,1);
```

```
        end
```

```
    end
```

```
    count = AppCount;
```

```
end
```

```
end
```

methods

% Create the application object

```
function obj = DataAcquisitionApp()
```

```
    obj.CurrClass = metaclass(obj);
```

```
    startApp(obj)
```

```
end
```

```
function value = get.AppPath(obj)
```

```
    appview = com.mathworks.appmanagement.AppManagementViewSilent;
```

```
    appAPI = com.mathworks.appmanagement.AppManagementApiBuilder.getAppManagement
```

```
    entApiCustomView(appview);
```

```
    myAppsLocation = char(appAPI.getMyAppsLocation);
```

```
    value = cellfun(@(x) fullfile(myAppsLocation, x), obj.AppPath,  
'UniformOutput', false);
```

```
end
```



```

% Start the application

function startApp(obj)

    % Put the application directory on the path

    %allpaths = genpath(obj.AppPath{:});

    %addpath(strrep(allpaths, [obj.AppPath{:} filesep 'metadata;'], ''));

    % Must load function (force by using function handle) or nargout lies.

    % Check if the app is a GUIDE app

    if nargout(@DAQmain) == 0

        eval('DAQmain');

    else

        obj.AppHandle = eval('DAQmain');

    end

    % Increment the reference count by one

    DataAcquisitionApp.refcount(obj.Increment);

    if(ishandle(obj.AppHandle))

```

```

% Setup cleanup code on figure handle using onCleanup object

cleanupObj = onCleanup(@()appinstall.internal.stopapp([],[],obj));

appdata = getappdata(obj.AppHandle);

appfields = fields(appdata);

found = cellfun(@(x) strcmp(x,'AppCleanupCode'), appfields);

if(~any(found))

    setappdata(obj.AppHandle, 'AppCleanupCode', cleanupObj);

end

elseif isa(obj.AppHandle,'handle') && ~isvalid(obj.AppHandle)

    % Cleanup in the case where the handle was invalidated before here

    appinstall.internal.stopapp([],[],obj)

end

end

end

end

function DAQmain

```

```
%DAQMAIN Data Acquisition GUI
```

```
dataAcqTool_export;
```

```
end
```

A.1.2 Spectrum Analysis

```
function output = bicoherence(x)
```

```
% This is file bicoherence.m. The function calculates
```

```
% the bicoherence of signals x = SP - PV
```

```
%
```

```
%
```

```
if length(x)/2 == round(length(x)/2)
```

```
else
```

```
    x = x(1:end-1);
```

```
end
```

```
% Segmentation of the input signal
```

```
LX = 64;    % segment length
```

```
LS = 128;    % DFT length
```

```
OV = 0.5;    % 50% overlap
```

```
k = 0;
```

```
cont = 0;
```

```
while cont == 0
```

```
    indices{k+1} = ((LX/2)*k+1:1:(LX/2)*k+LX+1);
```

```
    values = indices{k+1};
```

```
    k = k + 1;
```

```
    if values(end)>length(x) - LX/2
```

```
        cont = 1;
```

```
    end
```

```
end
```

```
numseg = length(indices);
```

```
% the while-loop above made the variable "indices" be of the correct dimension
```

```
% to use the overlapping DFT-calculation of the input signal.
```

```
% Construction of the bispectrum
```

```
for ix = 1:length(indices)
```

```
clear mu x1 w x2 Y Bsp de1 de2
```

```
% Remove the mean
```

```
mu = mean(x(indices{ix}));
```

```
x1 = x(indices{ix}) - mu;
```

```
% Multiplication with the Hanning-window. Reference : page 547 in
```

```
% Numerical Recipes
```

```
for k = 1:length(x1)
```

```
    w(k) = 0.5 - 0.5*cos(2*pi*(k-1)/(LX-1));
```

```
end
```

```
x2 = w(:).*x1(:);
```

```
% Calculation of the DFT (Y)
```

```
Y = fft(x2,LS);
```

```

for k = 1:LX

    for l = 1:LX

        Bsp(k,l) = Y(k)*Y(l)*conj(Y(k+l));

        de1(k,l) = abs(Y(k)*Y(l))^2;

        de2(k,l) = abs(Y(k+l))^2;

    end

end

D1{ix} = de1; % Denominators in eq. 2 in Diagnosis... (Chudhury)

D2{ix} = de2;

Bs{ix} = Bsp;

end

% Calculation of the mean of the bispectrum and the bicoherence

D1m = D1{1}; D2m = D2{1}; Bm = Bs{1};

for k = 2:length(Bs);

    D1m = D1m + D1{k};

    D2m = D2m + D2{k};

end

```

```

    Bm = Bm + Bs{k};

end

D1 = D1m/k; D2 = D2m/k; Bm = Bm/k;

bic2 = zeros(LX*2);

for k = 1:LX

    for l = 1:LX

        bic2(k+LX,l+LX) = abs(Bm(k,l))^2/(D1(k,l)*D2(k,l));

    end

end

for k = 1:LX*2

    for l = 1:LX*2

        if (k <= LX)&(l <= LX)

            bican(k,l) = bic2(2*LX-k+1,2*LX-l+1);

        elseif (k > LX)&(l <= LX)

            bican(k,l) = bic2(k,2*LX-l+1);

        elseif (k <= LX)&(l > LX)

```

```

        bican(k,l) = bic2(2*LX-k+1,l);

elseif (k > LX)&l > bic2(k,l);

        bican(k,l) = bic2(k,l);

    end

end

end

end

bicanpl = bican;

bican = bican(LX+1:LX+LS/2,LX+1:LX+LS/2);

waxis = linspace(0,0.5,length(bican)+1);

waxis = waxis(1:end-1);

limit = waxis(end)*(2/3);

k = 1;

while k < length(waxis)

    if waxis(k)>limit

        limit = k-1;

        k = Inf;
    end
end

```



```

else

    k = k + 1;

end

end

end

for f1 = 1:limit

    for f2 = 1:length(waxis)

        if f2 == 1 | f2 >= f1;

            bican(f1,f2) = 0;

        end

    end

end

end

for f1 = limit:length(waxis)

    for f2 = 1:length(waxis)

        if f2 == 1 | f2 >= -2*f1 + length(waxis)*2

            bican(f1,f2) = 0;

        end

    end

end

```

```

    end

end

cont = 1;

for f1 = 1:length(waxis)

    for f2 = 1:min([f1, -2*f1+length(Y)]);

        bicpermed(cont) = bican(f1,f2);

        cont = cont + 1;

    end

end

bic2m = mean(bicpermed);

bic2v = std(bicpermed);

bic2max = max(bicpermed);

surf(waxis,waxis,bican');

axis([0 0.5 0 0.5 0 1]);

%set(hcc,'view',[145 15],'Alim',[0 1],...

```

```
% 'Clim',[0 0.08]);  
  
view([145 15])  
  
[c,rows] = max(bican');  
  
[c,column] = max(max(bican'));  
  
f1 = rows(column);  
  
f2 = column;  
  
output.f1 = waxis(f1);  
  
output.f2 = waxis(f2);  
  
return
```

A.1.3 NI Card Data Acquisition

```
close all  
  
%clear all  
  
d = daq.getDevices;  
  
s = daq.createSession('ni');
```

```
s.Rate = 2000000;  
  
s.DurationInSeconds = 1;  
  
addAnalogInputChannel(s,'Dev1',0,'Voltage');  
  
[data,time] = s.startForeground();  
  
plot(time,data)  
  
xlabel('Time (secs)');  
  
ylabel('Voltage')
```

A.1.4 Signal Spectrum plots

```
% dt - Sample Time of data, .001 sec
```

```
% u - Input signal, 1x10000
```

```
% y - Output signal, 1x10000
```

```
N = length(u);
```

```
N2 = floor(N/2);
```

```
MagData = abs(fft(y)/fft(u));
```

```
PhaseData = angle(fft(y)/fft(u)); % rad/sec
```

```
FreqData = [0:N-1]/(N*dt); % Hz
```

```
subplot(211); semilogx(FreqData(1:N2),MagData(1:N2));
```

```
subplot(212); semilogx(FreqData(1:N2),PhaseData(1:N2));
```

A.1.5 Power Spectrum Density Calculation

This program calculates and plots power spectrum density

```
x=chA;
```

```
N=length(x);
```

```
delt=time(2,1)-time(1,1);
```

```
Fs=1/delt;
```

```
freqx = 0:Fs/N:Fs/2;
```

```
%%-----Power Spectrual Density
```

```
xdft = fft(x);
```

```
xdft = xdft(1:N/2+1);
```

```
psdx = (1/(Fs*N)) * abs(xdft).^2;
```

```
psdx(2:end-1) = 2*psdx(2:end-1);
```

```
plot(freqx,10*log10(psdx))
```

```
grid on
```

```
title('Periodogram Using FFT')
```

```
xlabel('Frequency (Hz)')
```

```
ylabel('Power/Frequency (dB/Hz)')
```

Appendix B Publications

B.1 Conferences

Through life Engineering Services November 2013 “Intermittent Fault Finding Strategies”

Through life Engineering Services November 2014 “Experimental Study of Fault Finding design/implementation”.

URSI August 2011 “Feasibility Study of Tumor Size Classification via Contrast-Enhanced UWB Breast Imaging – A Complex-Domain Analysis”

Conference paper for ICEAA'12 “Feasibility Study of Tumor Morphology Classification via Contrast-Enhanced UWB Breast Imaging – A Pole-Zero Analysis”

B.2 Journals

Wakil Ahmad Syed, Suresh. P., Mohammad. S., Ian. J., 2015. A Carrier Signal Approach for Intermittent Fault Detection and Health Monitoring for Electronics Interconnections System. *IJACSA*, 6(12), pp. 144-150.

Wakil Ahmad Syed, Suresh. P., Mohammad. S., Ian. J., 2016. A Novel Intermittent Fault Detection Algorithm and Health Monitoring for Electronic Interconnections. *IEEE TRANSACTIONS ON COMPONENTS, PACKAGING AND MANUFACTURING TECHNOLOGY*, 6(3), pp. 400 - 406 .

Intermittent Fault Detection and Health Monitoring for Electronics Interconnections Using Channel Sounding (submitted)

Appendix C List of Figures and Equations

C.1 List of Figures

Figure 1.1 Fault Detection Diagnosis Rates for Aerospace Repairs (Huby & Cockram, 2010).....	5
Figure 2.1. NFF and its sub-categories	15
Figure 2.2. Major causes of intermittency in electronics devices.....	17
Figure 2.3. Degradation and its effect on different components	19
Figure 2.4. Working principle of latching continuity test.....	27
Figure 2.5. Threshold trigger circuit	28
Figure 2.6. Automatic test equipment vs. analogue neural network	35
Figure 2.7. Model based diagnostics diagram	38
Figure 2.8: Relation between intermittent faults and degradation.....	45
Figure 2.9 Two state Markov model	47
Figure 2.10. Aircraft Wiring Model (Alstine & Allan, 2005).....	48
Figure 2.11. NFF/Intermittent Interconnection and Detection Model	49
Figure 3.1 Shaker for Intermittent Fault Generator.....	52
Figure 3.2 Components of intermittent fault generator	53
Figure 3.3 Single Point Intermittent Fault Generator	53
Figure 3.4 Experimental Setup Diagram	55
Figure 3.5. Experimental setup to monitor intermittency using n-compass	55
Figure 3.6. N-Compass displaying intermittency in the circuit.....	56
Figure 3.7. Test Signal of Open Circuit.	58
Figure 3.8. Test Signal for Close circuit.....	59
Figure 3.9. Picoscope persistence mode	60
Figure 3.10. Persistence display mode	61
Figure 3.11. Experimental setup to monitor intermittency using oscilloscope ..	62
Figure 3.12. Oscilloscope to monitor intermittency.....	63
Figure 3.13 Multipoint Ethernet Intermittent Test Rig	64

Figure 3.14 Test Results for Multipoint Intermittent Generator	65
Figure 4.1. Intermittent Fault Detestability (Bryan, et al., 2008).....	69
Figure 4.2 Ladder Network IF Detection Block Diagram	72
Figure 4.3. State Representation of Intermittent Fault Detection System	73
Figure 4.4. Intermittent Fault Detection Algorithm	74
Figure 4.5. Intermittent Fault Detection Circuit Schematics.....	77
Figure 4.6. Input / Output Wave Form of Intermittent Fault Detection Circuit – Profile 1	78
Figure 4.7. Frequency Domain Plot of Input (dotted)/Output(solid) of Profile 1	79
Figure 4.8 simulation of profile 2	80
Figure 4.9. FFT Plot of Input Signal of Profile 2.....	80
Figure 4.10. FFT Plot of Output Signals of Profile 2	81
Figure 4.11. Ethernet Male and Female Socket with Cable Connection as an Intermittent Test Rig	82
Figure 4.12. Experimental Setup for Intermittent Fault Detection	82
Figure 4.13. Test Signal of Open Circuit	84
Figure 4.14 Test Signal for Close circuit.....	84
Figure 4.15. Intermittent Fault Detection Measurements - Profile 1.	85
Figure 4.16. Intermittent Fault Detection Measurements, Profile 2.....	85
Figure 4.17. Output Profile 2.	85
Figure 4.18. Output Profile 1	86
Figure 5.1. Block Diagram of IF detection Algorithm	96
5.2 Intermittent Fault Detection Algorithm	98
Figure 5.3. Ethernet Male and Female Socket with Cable Connection as an Intermittent Test Rig	99
Figure 5.4 Experimental Setup for Intermittent Fault Detection	99
5.5 Input sine wave to unit under test.....	101
Figure 5.6 Received noisy signal with IF information.	101
Figure 5.7 AM Demodulated Signal.....	102

Figure 5.8 Frequency Demodulated Signal with 20 Hz Shaking Connector ...	103
Figure 5.9 Phase Demodulated Signal with shaking 20 Hz External Vibration to a connector.....	104
Figure 5.10. Spectrum of Intermittent signal.....	104
Figure 6.1. Channel Impulse Response	116
Figure 6.2. PN Code Generation	118
Figure 6.3. Typical DS-SS Communication System	119
Figure 6.4. Block Diagram of Multi Node Intermittent Fault Detection using Channel Sounding.....	122
Figure 6.5. Two point Intermittent Fault Detection.....	124
Figure 6.6. Scope 5 Shows Transmitter 1 Output before Channel	125
Figure 6.7. Scope 1 Shows Channel Intermittent Fault	125
Figure 6.8. Scope 2. Shows Channel Intermittent Fault	126
Figure 6.9. Scope 3. Shows Poor De-spreading due to wrong Orthogonal Code	126
Figure 6.10. Scope 4 Shows perfectly synchronised PN code.	127
Figure 6.11 Experimental Setup	128
Figure 6.12. Experimental setup Block Diagram	129
Figure 6.13. Scope 1 with same PN code De-spreading.....	130
Figure 6.14. Scope 2 with same PN code De-spreading.....	131
Figure 6.15. Scope 3 with Different PN code De-Spreading	131
Figure 6.16. Scope 4 Node 2 with Same PN Code De-Spreading	132

C.2 List of Equations

$V_n = Z_2 A \sin(2\pi f t) (Z_1 + Z_2)$ (1).....	72
$y_t = h t, \tau * x_t$(2).....	116
$Y_f = H_f . X_f$(3).....	116
$H_f = Y_f / X_f$(4)	116
$X(z) = \sum_{n=0}^{\infty} x(n) z^{-n}$(5).....	116

$H(z) = Y(z)X(z) = y_0 + y_1z^{-1} + \dots + y_{n-1}z^{-(n-1)} + y_nz^{-n} - nx_0 + x_1z^{-1} + \dots + x_{n-1}z^{-(n-1)} + x_nz^{-n}$(6)	116
$H(2) = 111 - 1$ (7)	119
$H^2N = HNHNHN - HN$(8)	120
$H^2N = HNHNHN - HN$(9)	120
$HNHN^0 = NIN$(10)	120

Appendix D Course Attended

- Design of experiment
- A beginners Guide to neural networks
- Introduction to ref-work
- Two days technical writing workshop
- Systematic innovation
- Essential people skills for success
- Papercraft-Publishing in peer review scientific Journals
- Communication your science to public and your peers
- Introduction to FPGA(STFC)
- Digital Design Verification(STFC)
- Digital IC Implementation and sign-off (STFC)
- Advance Digital Signal Processing (MSc Module)
- Machine Learning (MSc Module)

