

The 5th International Conference on Through-life Engineering Services (TESConf 2016)

Health Management Design Considerations for an All Electric Aircraft

Robin.K.Sebastian^{a, b*}, Dr. Suresh Perinpinayagam^b, Raj Choudhary^b.

^aHindustan Aeronautics Limited, Bangalore, Aircraft Research and Design Centre, Karnataka, 560037, India.

^bIVHM Center, Cranfield University, Bedfordshire, MK43 0AL, UK.

* Corresponding author. Tel.: +44 7404710740; E-mail address: robinksebastian@yahoo.co.in, robin.kuttikkadan-sebastian@cranfield.ac.uk

Abstract

This paper explains the On-board IVHM system for a State-Of-the-Art “All electric aircraft” and explores implementing practices for analysis based design, illustrations and development of IVHM capabilities. On implementing the system as an on board system will carry out fault detection and isolation, recommend maintenance action, provides prognostic capabilities to highest possible problems before these became critical. The vehicle Condition Based Maintenance (CBM) and adaptive control algorithm development based on an open architecture system which allow “Plug in and Plug off” various systems in a more efficient and flexible way.

The scope of the IVHM design included consideration of data collection and communication from the continuous monitoring of aircraft systems, observation of current system states, and processing of this data to support proper maintenance and repair actions. Legacy commercial platforms and HM applications for various subsystems of these aircraft were identified. The list of possible applications was down-selected to a reduced number that offer the highest value using a QFD matrix based on the cost benefit analysis. Requirements, designs and system architectures were developed for these applications. The application areas considered included engine, tires and brakes, pneumatics and air conditioning, generator, and structures. IVHM design program included identification of application sensors, functions and interfaces; IVHM system architecture, descriptions of certification requirements and approaches; the results of a cost/benefit analyses and recommended standards and technology gaps. The work concluded with observations on nature of HM, the technologies, and the approaches and challenges to its integration into the current avionics, support system and business infrastructure.

The IVHM design for All Electric Hybrid Wing Body (HWB) Aircraft has a challenging task of addressing and resolving the shortfalls in the legacy IVHM framework. The challenges like sensor battery maintenance, handling big data from SHM, On-Ground Data transfer by light, Extraction of required features at sensor nodes/RDCUs, ECAM/EICAS Interfaces, issues of certification of wireless SHM network has been addressed in this paper. Automatic Deployable Flight Data recorders are used in the design of HWB aircraft in which critical flight parameters are recorded.

The component selection of IVHM system including software and hardware have been based on the COTS technology. The design emphasis on high levels of reliability and maintainability. The above systems are employed using IMA and integrated on AFDX data bus. The design activities has to pass through design reviews on systematic basis and the overall approach has been to make system highly lighter, effective “All weather” compatible and modular. It is concluded from the study of advancement in IVHM capabilities and new service offerings that IVHM technology is emerging as well as challenging. With the inclusion of adaptive control, vehicle condition based maintenance and pilot fatigue monitoring, IVHM evolved as a more proactively involved on-board system.

© 2016 The Authors. Published by Elsevier B.V. This is an open access article under the CC BY-NC-ND license (<http://creativecommons.org/licenses/by-nc-nd/4.0/>).

Peer-review under responsibility of the scientific committee of the The 5th International Conference on Through-life Engineering Services (TESConf 2016)

Keywords: CBM;CAD,HWB,DMO,IVHM,OSA-CBM

1. Overview

The aeronautical industry has, for several years, involved in addressing and solving the shortfalls in the legacy aircraft design, which has now been cultured to the point of

shrinking revenues. The conventional airliner in which commuters are held in tubular fuselage carried by wings with larger aspect ratio, propelled by traditional turboshaft engines and stabilized by aft tail, there is little scope for refining or improving the aerodynamic and propulsive efficiency.

Moreover, in the new era of air transport demanding lower direct operating cost, more environmentally compassionate aircraft with fewer noise and CO-2 emission, compatibility to alternate fuel and higher capacity commuting, for which conventional configuration will not support the airline infrastructure. There has been reluctance to depart from a direct advancement of prevailing technology, the reason for which will not be discussed here, however, it is now appropriate to study the possibility of alternate solutions [1].

The novel concept of Hybrid Wing Body (HWB) is considered as one of the possible solution, in which the fuselage and wing merge together to form a tailless aircraft analogous to a flying wing with enlarged centre section for carrying the commuters. Whilst there have been sequences of curiosity in flying wing and blended wing body aircraft design over the past few years. It is only recently that a stronger knowledge about the configuration has been attained. Thus understanding shared with a number of new expertise has unlocked the way for a novel configuration. Perhaps capable of offering a quantum leap in aircraft efficiency and performance[2].

There has been a drastic improvement in the electrical propulsion technology during the recent past with the development of high efficiency electric motors, high density storage devices, and converter technology. To enlarge vehicle performance adequate to fulfil NASA's "N+3" objectives, the HWB airframe designed for 'N+2' was continued but the propulsion system upgraded using Turbo electric Distributed Propulsion (Te-DP) system[1],[2].

The aircraft is using novel technology like Distributed electric Propulsion, Cryogenic cooling and high density energy storage for which maintenance is an actual test and hence having an On-board IVHM system becomes vital for these technology.

The key to successfully developing, implementing and operating an IVHM system is to ensure its results in economic gains for those who invest time, resources, and money in it. The main economic benefits of using IVHM are maintenance cost avoidance and Increase of revenue by improving availability. There are secondary benefits such as flight testing, crew training and quality assurance. It monitors aircraft systems, subsystem structure, and propulsion system using a combination of state of the art sensor networks and prognostic and diagnostic reasoning and support the maintenance action. Also the IVHM system will monitor the pilot health and fatigue[5].

This paper addresses development of an On-board Integrated Vehicle Health Management System (IVHM) for the Hybrid Wing Body (HWB) aircraft which embeds the best capabilities like quieter, cleaner and efficient Turbo Electric Distributed Propulsion using Superconducting Generator and Motor with Cryogenic/ Liquid Hydrogen Cooling System. However it also inherits some of the worst drawbacks of Distributed Electric Propulsion concept and maintenance figures in the top ones. In view of this, having an intelligent on-board maintenance system becomes a necessity[1].

The IVHM design for Hybrid Wing Body Aircraft has a challenging task of addressing and resolving the shortfalls in the legacy IVHM framework. The challenges like sensor

battery maintenance, handling big data from SHM, On-Ground Data transfer by light, Extraction of required features at sensor nodes/RDCUs, ECAM/EICAS Interfaces, issues of certification of wireless SHM network has been addressed in the thesis. Automatic Deployable Flight Data recorders are used in the design of IVHM system in which critical flight parameters are recorded.

2. Requirements

The objective of the design process is to convert customer requirements, and design constraints into a fairly satisfactory system solution. A nominal system should be designed for maintainability, availability, reliability, supportability, survivability develop-ability, safety, Interchangeability. System design shall progress in an orderly and consistent manner though a process of functional breakdown and traceability of requirements, that initiates with the system functional architecture and finally results in design specifications for the system to be engineered. The avionics system development process followed the V-model which is extensively used and established system development life cycle made in aeronautical industry.

Development of complex systems needs to be based on formal requirements management processes, including formal requirement capture, validation, allocation and verification. The V model of system/component design, implementation and verification is presented in Figure 1-1 for the IVHM case. Taking the V-model as the baseline the IVHM system design covers the requirement capture and the subsequent process.

2.1 Requirement capture and Analysis

A detailed and well documented requirement capture during the project definition phase itself is vital in any design project. Adding new requirements or realizing the same at the later stage of the project can have substantial consequence on the design process and may lead to economical and time repercussions. The aircraft level avionics requirements and certification requirements were used as the baseline to generate the aircraft level requirements of IVHM system. These requirements were further classified in to two category such as functional and nonfunctional.

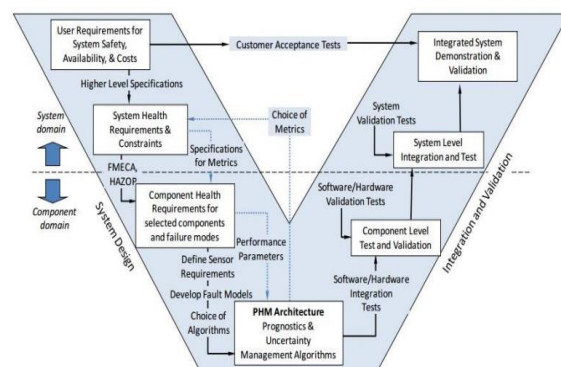

Fig 1-1 V Model for IVHM development [4]

Aircraft level FHA was carried out based on ARP-4761 guidelines to identify the hazardous functionality failures.

After completing the aircraft level FHA process, system level requirement capture has been carried out, which details the precise system level functionalities of the IVHM system. This process was followed by the development of a detailed IVHM functional architecture. This architecture establishes the functions that have to be performed along with its logical sequences and performance requirements. After the development of functional architecture, a system level FHA has been carried out to identify the criticalities of various failures. After the FHA process, a PSSA process which is a top-down approach is performed by using the analysis of FHA. This is done to perform architecture validation and allocating safety margin to the different components of architecture.

After completing the PSSA process, COTS hardware components both for the modular avionics and also with FDR and pilot image camera were selected. The selection of airframe system sensors, structural sensor network and pilot health monitoring network were done. The zone wise segregation of sensor networks and related cable harness are also done to improve the maintainability and to support the Design for Manufacturing and Operation (DMO) concept. The sensor network and related cable harness are designed such that aircraft have protection from EMI/EMC, static discharge, rainwater and lightning so as to get all weather clearance. In order to differentiate IVHM cables from aircraft cables proper cable identification has been followed. Lastly a SSA process is done to ensure that the system design meets the target laid in the PSSA phase.

2.2 Aircraft level requirements

The high level IVHM requirements have been mainly categorized as functional and non-functional requirements. Each requirement is identified by means of unique numbering system, which indicates the category of requirements. Such that the traceability during verification and validation phase. This is then followed by analysis of the requirements.

The top level aircraft requirements capture and its documentation was the first step in the design of All Electric Hybrid Wing Body (HWB) Aircraft. Requirement specification is an elaboration, development, and transformation of the requirement into engineering terms. It delivers communication among marketers and engineers, clients and consultant, engineers in different discipline, and the project team. A nominal requirement must have following characteristics such as solutions independent, complete, clarity, concise, testability and traceability.

The requirements are predominantly inclined towards the end user needs, certification procedure, design constraints, target performance, maintenance criteria and safety needs. From a systems engineering perspective, IVHM system typically have many more stakeholders whose needs have to be considered. These includes MRO personnel, operator, crew, fleet manager, Regulatory authorities, owner, General public, OEMs, Third party IVHM provider etc. Each of these groups is looking for something different from the system.

As the project specification are the solitary initial input for the aircraft design, the baseline aircraft requirements were

formulated first and then each system group created the top level requirements based on these requirements. The avionics team generated the top level requirements for All Electric Hybrid Wing Body (HWB) Aircraft avionics system through intense brainstorming and research study. The fact that the time spent on requirement capture is 1/4th of the overall project time indicates the criticality and importance of proper requirement capture to the effective implementation of the project. The requirement document provides a baseline against which compliance can be measured. These requirements are also used to provide the stakeholders with a basis for approval of the system, and also provides the project management team the basis for estimating cost and schedules, will assist the designer to reduce the design effort because of less rework required to address poorly written, missing and misunderstand requirements.

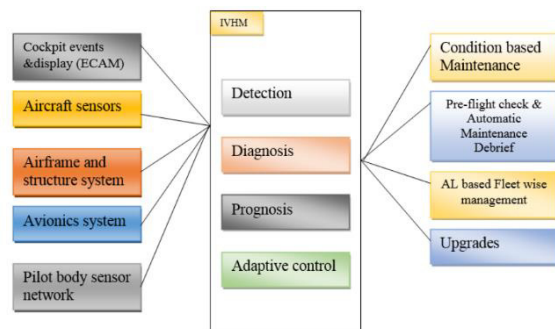

Fig 1-2 Block Diagram of IVHM System

3. Design Concept

3.1 Aircraft level FHA for IVHM

FHA is done in the initial phase of the aircraft design process, using qualitative assessment, by which aircraft level functions are described and analyzed for various failure conditions. Each failure conditions are assigned with a hazard classification such as Catastrophic, Hazardous, Major, Minor, etc. which are closely related to Development Assurance Levels (DALs) and are aligned between ARP-4761 and related aerospace safety documents.

3.2 System level requirements for IVHM

Fish bone methodology is used to generate IVHM system level requirements. The top level IVHM functional system requirements are mainly classified as Operational, Performance, Customer/user, Physical / Installation, Maintainability and Certification requirements.

3.3 IVHM System architecture

The IVHM system utilizes the data available on the avionics data bus and data from the existing system sensors to maximize the level of possible data/feature extraction. This has been carried out by using a “sensor capture template” and circulated among the airframe systems and structure designers. To explain the interfaces with IVHM system, an “Interface Definition Document” were formulated and circulated along with the

Minor category. However, due to critical role played by IVHM in ECAM/EICAS for monitoring and briefing the overall health of the aircrafts, make it more critical. The failure of this function has a significant effect on pilot workload. The proposed migration has been achieved through distributed intelligence in the IVHM core computer in which one processor has been exclusively dedicated for ECAM/EICAS functionality and Automatic Logistics System controls. The key functionalities of the IVHM system are analyzed for failure and the associated impacts. Based on these analysis the severity categorization is carried out.

3.4 Safety targets for IVHM

PSSA, which is a methodical study of the proposed IVHM system architecture, has been carried out to determine how these functionality failures can lead to functional hazards, which are identified by the FHA process. After the study, safety targets have been assigned to the different IVHM system modules. There are two methods available for carrying out PSSA, such as Fault Tree Analysis (FTA) and Dependency Diagram. For IVHM, PSSA process, FTA approach has been used for arriving at safety targets. FTA is a deductive failure analysis uses top down approach which forces on undesired event and analyse the reason for the events using Boolean logic to combine series of low level events. The aircraft level FHA of the system categories the IVHM system in the Minor category and has allowable qualitative probability as probable (1×10^3).

Sl no	Equipment/LRU name	P/N:	Supplier	QPA
1	RDCU	RIU-175 Remote Interface Unit	GE Aviation	3
2	IVHM Core computer	VPX3-1259 3U VPX Intel Core i7 Broadwell SBC	Curtis Wright	2
3	IVHM Memory module	Flash Storage Module (FSM) 2TB	Curtis Wright	1
4	ARINC 717 Interface	LE429-5/14R14T/717	Ballard technologies	1
5	Pilot Vision Camera	Vision 1000	Appareo systems	1
6	Deployable SSFDR/ELT	DRS FDR/ELT	DRS Technologies (Recorders and ELT)	1

Table-1 ESOP for IVHM System

The system level design of the IVHM system is centered on the identified functional requirements as explained in the previous chapters, which include data acquisition from numerous sensors and sensor network comprising pilot BSN, avionics LRUs and airframe systems followed by the feature extraction at sensor node/RDCU, data processing/analyses and ECAM/Maintenance briefing/recording activities as necessary. The scope of this important section covers the modality of execution and hardware design, COTS based module selection and its justification for these functionalities.

3.5 Structural Health Monitoring (SHM)

Latest improvements in reliable sensing technology, microprocessors, and digital signal processing has empowered a novel group of smart airframe structures & materials to be realized in All Electric Hybrid Wing Body (HWB) Aircraft structural design and HM. The smart sensors will collect data and do the required pre-processing and sent to the sensor node located nearer to the sensor cluster which were arranged zone wise across aircraft. However, in order to provide sensing networks which are truly autonomous, it is significant to eliminate the need for battery maintenance/battery replacement. A state of the art sensor node (Area Manager) and Local node (sensors) concept with Energy harvesting and

Power Management system for SHM has been employed in All Electric Hybrid Wing Body (HWB) Aircraft.

3.5.1 Airframe SHM sensor nodes

A typical wireless sensor node concept used in structural health monitoring of All Electric Hybrid Wing Body (HWB) Aircraft is shown in the Figure 1-4. The wireless sensor network works on the IEEE 802.15.4, ZigBee protocol and distributed across aircraft and connected to the sensor cluster over the regions such as Landing gear attachment, Electrical Fan attachment, Engine mount, Spoilers etc.

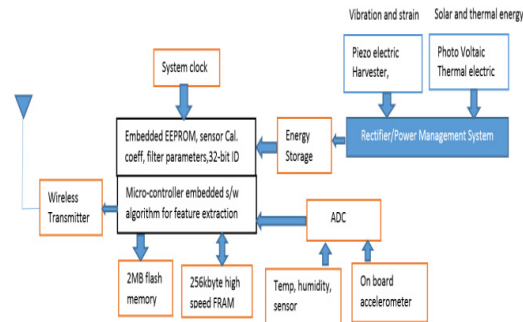

Fig 1-4 Wireless Sensor Node for SHM

Area node/ Area Manager is the second level processing capability that performs system/subsystem HM integration and manages communications to the central node and to lower level local nodes. Local node (Sensor level) is a third level processing capability which primarily interfaces with sensors. A local node can be a smart sensor. A sensor can provide input to any level node. Area and local nodes are data concentrators/sensor nodes with processing, storage and interfaces to support the implementation of the node functionality. The various functions resident in the on-board sensor nodes and its processing modules are Physics or Data Driven Models, Transforms (e.g., Fast Fourier Transforms, STFT), Sensor/Feature Fusion, Filters (e.g., Notch, Kalman and Particle Filters), Arithmetic/Small Model (Arithmetic and logical), Large Logical Constructs/Reasoner (e.g., Model-based Diagnostic Reasoners at the Management Level) Airframe system SHM application for All Electric Hybrid Wing Body (HWB) Aircraft.

Smart sensor nodes are proficient of functioning at inferior power levels. These are accomplished by merging periodic, timed wake-up signal processing module and pulsed sensor excitation with microcontroller based power management system. The features from the data were extracted at sensor level and sent only the required information through RF transmitter and will reduce the battery power depletion because of not sending the raw data which need power for constant transmission. The batteries used in sensor nodes should have small leakages, capable of trickle charging from micro-wattage source, High/charge discharge cycle and support peak energy pulses. A wireless sensor node SG Link-LSRS, P/N: 6308-3000, from M/s Micro-Strains has been used in All Electric Hybrid Wing Body (HWB) Aircraft.

SG Link sensor node support wide range of analog sensors such as strain gauges, load cells, pressure sensors, accelerometer and thermocouples etc., with remote long time deployment capability along with battery power management.

These methodology already implemented in Bell Helicopters/Textron, Bell Model-412 helicopter pitch link health monitoring and in Sikorsky H-60, Blackhawk helicopter. These results indicates the practical implementation and feasibility on All Electric Hybrid Wing Body (HWB) Aircraft. It is compatible use the Wireless Gateways from M/s. Micro-Strain, WSDA-1000, which works as a wireless data aggregator will collect data from individual sensor nodes which are allotted with unique RFID for component tagging and tracking. Tracking of load history of the components combined with Inertial GPS information provided by wireless module MICRO-AHRS from M/s. Micro-Strain has been employed. Data collected during flight would be automatically recorded on-board, without wireless communication, since each wireless sensor nodes are processing the raw data and only extracted features have been stored. This will further reduce on-board interference due to SHM network and battery depletion due to continuous usage for RF transmission. After aircraft lands, the on-aircraft gateway (WSDA-1000) would query the wireless sensor nodes and prepare the data files and sent through communication links.

The wireless sensor node concept with feature extraction technique has been proposed for All Electric Hybrid Wing Body (HWB) Aircraft. A trade-off study between using wireless network in SHM and using a shared architecture with only extracted feature sending to the bus has been considered along with immunity to interference, EMI/EMC effect inside commercial aircraft as per RTCA/DO160E requirements, data security, weight, cost and certification aspects. Designing proprietary wireless links for AWSNs can be costly, which can significantly discourage the adoption of AWSNs even if their applications can be approved by FAA. IEEE 802.15.4 ZigBee protocol which is an established wireless network has been considered for the wireless SHM sensor network on All Electric Hybrid Wing Body (HWB) Aircraft, because of the following advantages [10].

(1) It is DSSS-based and thus has a certain level of protection to interferences from outside signals.

(2) It uses CSMA-CA to carry multiple transceivers on the same frequency channel thus suitable for multi sensor data network application.

(3) It works in ISM, 2.4 GHz band, with 16 channels in this band and can co-exist with Wi-Fi and Bluetooth, with acceptable immunity to interference.

(4) It has sufficiently high data rate required for SHM feature transmission.

(5) The radiation level from the transmitter is low thus the effect of ZigBee over other system will be lower.

(6) The maximum range obtained with ZigBee network is 10-100 meter, with our aircraft wing span (69 m max) it is possible to in cooperate there system on board with better connectivity.

The major constraints for the implementation is the certification of the system and the cost and weight budget of having an independent data bus for structural data transfer. It is always challenging and interesting to introduce a new technology in to aerospace industry. However, as per the new regulations from FAA, it is possible to certify the non-critical systems using wireless communications such as cabin air control and inflight entertainment system. In the coming decades it may be possible to certify the Wireless data bus with COTS components. Moreover, considering the operation

timeframe of 2030-35 for All Electric Hybrid Wing Body (HWB) Aircraft, it is possible to implement and certify the wireless SHM network on aircraft. It was decided to introduce wireless SHM network on All Electric Hybrid Wing Body (HWB) Aircraft [10].

3.5.2 Airframe sensors

The Airframe sensor instrumentation includes attaching sensor or sensor network to the aircraft structural components which need to be monitored for structural integrity and degradation. An effective sensor network should be analogous to the neuron system of human body and are in-situ on the structural component. The sensor/sensor network monitors the required parameters such as stress, strain, vibration, or electrical resistivity etc. The output of these sensors are generally electrical signal proportionate to the variation in parameters to be monitored. All Electric Hybrid Wing Body (HWB) Aircraft with Te-DP system have 14 Electric fans as propulsion device and expected to have more vibration in the fan attachment zone. The Turbo Generators which are located in the wing tips may experience more vibration and need to be monitored by IVHM system. These vibration can be extended to the fuselage and may cause

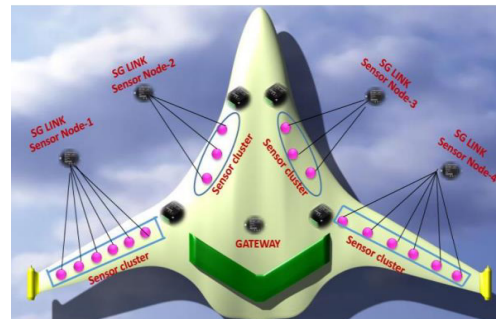

Figure 1-5 Wireless sensor network

passenger discomfort. These increased vibration also indicating the degraded structural integrity and performance. Thus having an effective on-board SHM is important for ease of maintenance and design benefits. Some of the SHM sensor used on All Electric Hybrid Wing Body (HWB) Aircraft have been described below.

3.5.3 Vibration Sensors

There are numerous reason in an aircraft for having normal and abnormal vibrations, such as mechanical faults, aerodynamic faults and turbulence, etc. All these vibrations have connected frequencies, but it is difficult for pilot and passengers to distinguish the same. Each aircraft has a unique vibration signature which is a result of mass distribution and structural stiffness that will results in vibration modes at definite frequencies. Abnormal vibrations are associated with different reasons such as rotor imbalance, mechanical failure, airflow disturbance over doors or control surfaces which has extreme wear or free play.

It is very hard for a pilot to differentiate various forms of vibration such as buffet, flutter, and noise for which the after effects are same in cockpit. Incorrect pilot judgment on the origin of engine vibration (switching off wrong engine) can cause catastrophic incident including loss of aircraft (e.g. Qantas 72, Airbus A330 crash incident). This demand for a more effective on-board SHM to assist the flight crew and maintenance personnel for an effective structural integrity

monitoring and passenger comfort. It is possible to generate more precise vibration measurement by means of acceleration, velocity and displacement. Piezo electric accelerometers are comprehensively used across airframe structure component over a broad range of frequencies in both time and frequency domain. The frequency range of the sensors needs to be designated carefully to capture the precise vibration data.

On All Electric Hybrid Wing Body (HWB) Aircraft wireless piezo electric sensor films available for strain, vibration, temperature, and humidity, manufactured by M/s Micro-Strain are placed with operating range of 5 KHz to 3 MHz These wireless sensors with energy harvesting techniques constitutes the state of the art SHM sensor network.

3.5.4 SMART Sensor Layer Film

SMART Layer SL-A designed by M/s. Acellent Technologies is a thin dielectric film with an embedded network of distributed piezoelectric sensors. The layer can also incorporate other types of sensors including strain, temperature, moisture and fiber optic sensors. The layer can be surface-mounted on structures or integrated into composite structures during fabrication. These are designed with both circular and D-Type connector with printed board cable connections are used with significant reduction in the cables and interconnections. These sensors also compatible with the wireless sensor nodes.

3.5.5 The Airframe sensor installation:

There are sensors placed in the Cargo and baggage compartment for smoke and fire detection. There are also vibration sensor placed in these zones to monitor the structural integrity. The Acellent sensor layers are placed over the cargo, passenger and under carriage door assembly. Acoustic sensors are placed on the leading edge of the wing for FOD and crack detection. Wireless temperature sensors are placed in the landing gear wheel and tyres. MEMS based energy harvesting shock and vibration sensors are placed over the landing gear attachment area

3.5.6 Aircraft system health monitoring

The All Electric Hybrid Wing Body (HWB) Aircraft employs new and emerging technologies such as Distributed electrical Propulsion or Te-DP with Cryogenic/LH2 cooled HTS cable grid, Fuel Cell as APU etc. The HTS grid cooled by Cryogenic pipelines and route through wing section in which leakages are expected and need continuous monitoring, Fuel cell in which fuel leakage and performance degradation expected, Li-Ion battery for which temperature changes and leakages are to be monitored. Any increase in the HTS cable grid temperature will cause the increased resistance and reduced power output at electrical fan motor terminals by which demands for a continuous monitoring by IVHM system. As per the discussion with the maintainability designer, blended wing body configuration of All Electric Hybrid Wing Body (HWB) Aircraft has the disadvantage of having the LRU removal and installation difficult. The LRU which are difficult for accessibility has been provided with more stringent health monitoring.

The IVHM system utilizes the prevailing airframe system sensors employed by the individual system designer along with the control and monitoring signal, which will deliver outputs w.r.t functioning of the parent systems such as Engine system, Electrical fans, Fuel system, Cryogenic cooling system, Fuel Cells, Electrical Batteries, Landing gear systems etc. shared in

the AFDX data bus or as separate analogue/discrete signal and are used to display the aircraft health and operational information to the pilots through ECAM/EICAS interface. In addition to that, IVHM system employs its own sensor network to collect additional data required for detailed data analysis. These include accelerometers, strain gauges, temperature sensors, humidity sensors, and thermocouple sensors, etc.

Area node/ Area Manager is the second level processing capability that performs system/subsystem HM integration and manages communications to the central node and to lower level local nodes. Local node (Sensor level) is a third level processing capability which primarily interfaces with sensors. Area and local nodes are data concentrators/RDCUs with processing, storage and interfaces to support the implementation of the node functionality. The various functions resident in the on-board sensor nodes and its processing modules are Physics or Data Driven Models, Transforms (e.g., Fast Fourier Transforms, STFT), Sensor/Feature Fusion, Filters (e.g., Notch, Kalman and Particle Filters), Arithmetic/Small Model (Arithmetic and logical), Large Logical Constructs/Reasoner (e.g., Model-based Diagnostic Reasoners at the Management Level) Airframe system SHM application for All Electric Hybrid Wing Body (HWB) Aircraft.

3.6 Visual Light Communication (VLC): On Ground data transfer for IVHM

The IVHM sensor and data network handles huge amount of raw data/features which need to be analyzed along with the historical trends at the airliner maintenance server for the major part of prognostic activity. Conventional aircrafts carry a QAR to collect these data and data retrieval could take 3 to 4 days depending on the location of the aircraft and aircraft availability.

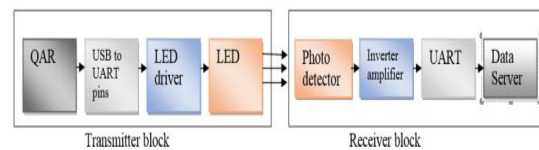
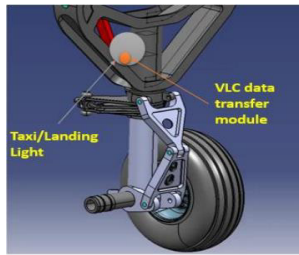

Fig 1-6 Block diagram for VLC data transfer

A new and innovative approach have been suggested for All Electric Hybrid Wing Body (HWB) Aircraft for on-ground data transfer. VLC or Li-Fi offers wireless transmission to offload much greater volumes of data on-ground, more quickly. The main advantage of using VLC are the following: It causes no EMR radiation to the environment, it is more secure than RF communication, and it can be retrofit easily in all aircrafts, the nose wheel landing light housing into which inserted an LED lamp enabled with visual light modulation controls. The access to the QAR is through a short length fibre optic cable. Visual Light Communication starts when aircraft stops at terminal gate. The current speed of data transfer is 1GB/sec and 10GB/sec technology Roadmap for 2020[11].



A retractable type light receiver 1-2m in front of the nose wheel at the terminal gate is connected to the airline maintenance system via airport fibre optic backhaul network. Now, other departments like operation control, maintenance and

Information System (SWIM) can share these information, which can be used to detect faults, to support operational decisions, to plan for future maintenance and arrange spare parts in advance.

The functional block diagram for data transfer by Li-Fi is shown in the Figure 1-6. The transmitter unit is mounted on Nose landing Gear inside the taxi/landing light assembly as shown in Figure 1-7. The data from QAR is connected via a fibre optic link and transmitted using LED which are driven by LED driving circuit. The receiver blocks are located 1-2meter near the airliner gateway. The received data using photo diode circuit will transmit to the airliner server for data processing. This is relatively new approach in which lots of research is going on. However, considering the operation timeframe of All Electric Hybrid Wing Body (HWB) Aircraft, it was decided to include this as an additional feature for On-ground data transfer. However, there is risk involved in the development and certification of this new approach. It was decided to consider QAR with data downloading port is suggested as the risk mitigation plan.

4) Safety Assessment

The SSA process is a bottom-up approach in which the reliability data available from the Hardware components has been compared with the safety target allotted for IVHM system components. The IVHM core computer has adequate level redundancy with single processor. Having said that, while designing the IVHM system with Minor hazard level, the ECAM functionalities has been allotted to a separate processor. The reason for having dual redundant IVHM processors is that IVHM handles functions of different safety criticality levels. While most of the system is 10-3, systems such as engine status messages were assessed as 10-5. Also by using two processors we can segregate the two and save on certification costs of developing the lower functions to a lower DAL. Also the second processor gives redundancy, if the processor hosting the 10-5 functions fail, the 10-3 functions will be stopped and the more critical IVHM functions will be hosted on the second processor. Thus provides a graceful degradation.

The required reliability rate for the IVHM system as per the safety targets set is 1×10^{-3} . Hence the system reliability exceeds the design requirement as specified for the minor category. Also it permits the system to be designed without additional or spare hardware in order to include redundancies. This is very critical given the stringent weight restrictions for avionics systems on the All Electric Hybrid Wing Body (HWB) Aircraft.

5) Conclusion and Discussion

This paper describes the systematic process of developing IVHM system, by achieving higher reliability standard and usage of modular architecture gives power as well as weight saving with adequate growth potential.

The work has extended the scope of IVHM

functionality for achieving the operational time frame target of 2030-35, and will see a drastic improvement from being a passive health monitoring entity to more proactive and involved system on-board. The existing shortfalls in the designs like sensor battery maintenance, big data handling from SHM sensor network have been addressed which then will forms the technology drivers for the IVHM design. A new and challenging wireless data transfer methodology has been adopted for SHM data transfer along with sensor node concept. A novel technology of data transfer by light has been suggested for data transfer on-ground. This involves certification and implementation challenge. Hence, the conventional data transfer using wired download port has been retained as the mitigation plan, in case of any potential risk. An Automatic Logistics control for the prognostics control has been suggested for All Electric Hybrid Wing Body (HWB) Aircraft design. The ECAM interface with the airframe systems and structure has been developed. A deployable type FDR has been developed and mounted on All Electric Hybrid Wing Body (HWB) Aircraft.

List of abbreviations

ACARE	Advisory Council for Aviation Research and Innovation in Europe
ACARS	Aircraft Communications Addressing and Reporting System
ATC	Air Traffic Control
ATM	Air Traffic Management
BIT	Built-In-Test
BSN	Body Sensor Network
CAA	Civil Aviation Authority
COTS	Commercially Of The Shelf
CO-2	Carbon Dioxide
CFD	Computational Fluid Dynamics
EASA	European Aviation and safety Agency
ECAM	Electronic Centralised Aircraft Monitoring
EICAS	Engine Interface and Crew Alert System
EMI/EMC	Electromagnetic Interference/ Compatibility
ETOPS	Extended Range Operation with Two-Engine Airplanes
EUROCAE	European Organisation for civil Aviation Equipment
FAA	Federal Aviation Administration
FADEC	Federal Aviation Administration
FEA	Full Authority Digital Engine Controller
FHA	Finite Element Analysis
FMECA	Functional Hazard Analysis
FMS	Failure Mode Effects & Criticality Analysis
FTA	Flight management System
HAL	Fault Tree Analysis
HM	Hindustan Aeronautics Limited
HTS	Health Monitoring
IMA	High Temperature Superconductor
IVHM	Integrated Modular Avionics

JSF	Integrated Vehicle Health Management		Prognostics: An Overview” AIAA Infotech@Aerospace 2010, Atlanta, Georgia, 20 - 22 April 2010.
LED	Joint Strike Fighter		
Li-Fi	Light Emitting Diode		
LRU	Light Fidelity Line Replaceable Unit	[5]	Ian. K. Jennions.; “The Developing Field of Integrated Vehicle Health Management” Journal of Aerospace science and Technologies, Volume 65, Issue 1A,pp 69-78,February 2013.
MCDU	Multipurpose Control Display Unit		
NASA	National Aeronautics and Space Administration	[6]	Intelligent Fault Diagnosis and Prognosis for Engineering Systems. G. Vachtsevanos, F. Lewis, M. Roemer A. Hess and B. Wu © 2006 John Wiley & Sons, Inc. ISBN: 978-0-471-72999-0.
NTSB	National Transportation and Safety Board		
OEM	Original Equipment Manufacturer		
OSA-CBM	Open System Architecture-Condition Based Maintenance	[7]	Capt. Giulio Cavello.; Andrew Hess.; Thomas Dabney.; “PHM a Key Enabler for the JSF Autonomic Logistics Support Concept” IEEE Aerospace Conference Proceedings, 2004.
PHM	Prognostics and Health Monitoring		
PSSA	Preliminary System Safety Assessment		
QAR	Quick Access Recorder	[8]	Kirby J. Keller.;Jeanne Maggiore.; Robab Safa-Bakhsh.; William Rhoden.; Michael Walz.; “Sensory Prognostics and Management System (SPMS)”SAE Technical Paper 2012-10-22,DOI: 10.4271/2012-01-2095.
SHM	Structural Health Monitoring		
SUGAR	Subsonic Ultra green Aircraft Research		
SSA	System Safety Assessment	[9]	Nicole L. Armstrong.;and Yahia M. M. Antar.; “Investigation of the Electromagnetic Interference Threat Posed by a Wireless Network Inside a Passenger Aircraft” IEEE TRANSACTIONS ON ELECTROMAGNETIC COMPATIBILITY, VOL. 50, NO. 2, MAY 2008.
UDLS	Universal Data Link System		
VME	Versa Module Euro card		

References

- [1] Felder, J. L., Kim, H. D. and Brown, G. V. (2009), "Turboelectric Distributed Propulsion Engine Cycle Analysis for Hybrid-Wing-Body Aircraft", AIAA-2009-1132, presented at 47th AIAA Aerospace Sciences meeting, 5-8 January 2009, Orlando, Florida, USA.
- [2] Kawai, R., Brown, D., Roman, D. and Olde, R. (Oct. 2008), Acoustic Prediction Methodology and Test Validation for an Efficient Low-noise Hybrid Wing Body 171 Subsonic Transport, NASA Contract NNL07AA54C, Phase 1 Final Thesis PWDM08-006A.
- [3] Kim, H. D. and Berton, J. J. (2006), Cruise-Efficient, Low-Noise, Short-Takeoff-and Landing de la Rosa Blanca, E., Hall, C. A. and Crichton, D. (2007), "Challenges in the Silent Aircraft Engine Design", AIAA 2007-454, Jan. 2007, Reno, Nevada, 45th AIAA Aerospace Sciences Meeting and Exhibit.
- [4] Abhinav Saxena.; Indranil Roychoudhury.; Jose R. Celaya.; “Requirements Specifications for
- [5] J Liu.; I Demirkiran.; T Yang and A Helfrick, “Feasibility study of IEEE 802.15.4 for Aerospace wireless sensor network” Digital Avionics System Conference,IEEE,2009.
- [6] Kavehrad, M. (2010). Sustainable energy-efficient wireless applications using light. IEEE Communications Magazine, 48(12), 66–73.
- [7] J. J. Ely, W. L. Martin, T. W. Shaver, G. L. Fuller, J. Zimmerman, R.L. Fuschino, and W. E. Larsen, “UWB EMI to aircraft radios: Field evaluation on operational commercial transport airplanes,” NASA Headquarters, Washington, DC, NASA/TP-2005-213606, vol. 1, Jan. 2005
- [8] T. X. Nguyen, S. V. Koppen, J. J. Ely, R. A. Williams, L. J. Smith, and M. T. Salud, “Portable wireless LAN device and two-way radio threat assessment for aircraft VHF communication radio band,” NASA Langley Res. Center, Hampton, VA, NASA/TM-2004-213010, Mar. 2004.

2017-03-02

Health management design considerations for an all electric aircraft

Sebastian, Robin K.

Elsevier

Robin K. Sebastian, Suresh Perinpinayagam, Raj Choudhary, Health Management Design
Considerations for an All Electric Aircraft, Procedia CIRP, Volume 59, 2017, pp102-110

<https://dspace.lib.cranfield.ac.uk/handle/1826/11618>

Downloaded from Cranfield Library Services E-Repository