

CoA/N-12

ST. NO. R12,052/B

U.D.C.

AUTH:

CoA Note No. 12

THE COLLEGE OF AERONAUTICS
CRANFIELD

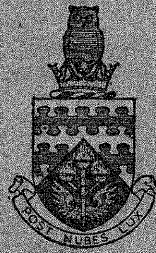

SOME BEARING MATERIALS UNDER HIGH
PRESSURES AT LOW ROTATIONAL SPEEDS

by

Lt(E). C. PRESTON, D.C.Ae., R.N.

R 12052/B

3 8006 10057 5920

NOTE NO. 12

JULY, 1954.

THE COLLEGE OF AERONAUTICS

C R A N F I E L D

Some Bearing Materials under High Pressures at Low
Rotational Speeds*

-by-

Lieutenant(E) C. Preston, Royal Navy,
D.C.Ae., G.I.Mech.E.



S U M M A R Y

A series of tests were carried out, in the Design Department of the College of Aeronautics, on plain journal bearings, at higher pressures than are normally encountered in engineering practice. Pressures of 40,000 lb/in.² were realised with a rubbing speed of 1.1 ft./min. Comparison between the various materials tested was effected by continuously rotating the bearings for fixed periods under various loads while friction and wear were measured periodically. The most outstanding combination was S.90 Chromium-plated running in a Hidurex Special bearing. Some other materials, listed in paragraph 8, were also found to be suitable although not so wear-resistant.

All the materials tested suffered some surface damage which, in general, proved not to affect the bearing performance.

An attempt is made to explain the behaviour of the bearings and thus indicate possible further materials which might prove suitable.

* Thesis presented in part fulfilment of the requirements for the Diploma award of the College.

CONTENTS

Introduction	Page 2
Method of Testing	Page 3
Description of Test Rig	Page 4
Description of Test Specimens	Page 6
Results	Page 9
Analysis of Results	Page 9
Conclusions	Page 12
Table 1, Abstract of Results	Page 14
Appendix I. Notes on the Friction and Wear of Bearing Materials	Page 15
Appendix II. Notes on the Choice of Materials and Lubricants for Tests	Page 16
Appendix III. Notes on the Appearance of Some Journals after Test	Page 17
Appendix IV. Details of Bearing Combinations Tested and Remarks on their appearance at intervals throughout the Tests.	Page 19

Figures 1 - 14.

2. Introduction

The advent of high-speed aircraft has introduced a need for bearings occupying as small a space as possible. Ball and roller bearings are often not sufficiently small for use in control hinges, power control connections, undercarriage pivots, wheel bearings, etc. There is space only for plain journal bearings operating under very high pressures. These pressures are very much higher than those encountered in general engineering practice.

A considerable amount of data exists for hydrodynamically-lubricated bearings operating at pressures up to 4,000 lb/in.² Very little is known about the behaviour of bearing materials under boundary lubrication conditions.

A series of bearing materials have been tested to determine which give the lowest friction and wear with both grease and solid lubrication. The results obtained established some bearing materials as suitable for any form of high pressure work. They also indicate why certain combinations such as steel on steel should not be used wherever sliding occurs under heavy pressure.

3. Method of Testing

3.1. Running Tests

The journal and bearing were cleaned with a degreasing fluid and then greased with Aeroshell XG-345, when the bearing combination required grease lubrication. The journals for the self-lubricating bearings were de-greased only. The bearing was then assembled; the thermocouple plug fitted in the bearing and the side supports bolted in place.

The bearing assembly was loaded to 5,000 lbs. i.e. 10,000 lb/in.² and the driving motor was then switched on. The grease groove in the bearing was filled by grease gun. Readings of frictional torque, temperature and the time were noted. Rotation of the journal was continued for 240 cycles (about 1 hour), readings being taken every 60 cycles, except near the commencement of rotation, when they were taken every 10 cycles. At the end of the hour the testing machine was off-loaded to allow the motors to cool. On recommencement of rotation for another 240 cycles under the same load the bearing was again charged with grease.

At the end of the 2 hour period the bearing assembly was dismantled and inspected, and the bearing bore measured in the vertical and horizontal planes by a Mahr internal measuring device capable of an accuracy of 1/10,000th inch. After inspection the bearing components were greased, reassembled and loaded to 20,000 lb/in.². The same procedure as before was then carried out. After 20,000 lb./in.² the bearing was loaded to 30,000 lb/in.² for 2 hours, and finally to 40,000 lb/in.² for 2 hours when the bearing still remained in a workable condition. Thus the programme was:-

0 - 2 hrs. approx.	0 - 480 cycles	10,000 lb/in ² load
2 - 4 hrs.	481 - 960	20,000 lb/in ²
4 - 6 hrs.	961 - 1440	30,000 lb/in ²
6 - 8 hrs.	1441 - 1920	40,000 lb/in ²

Greasing every hour, Inspection every 2 hours.

3.2. Measurement of Specimens

3.2.1. Measurement of the Bore of the Bearings

A Carl Zeiss Horizontal Comparator was used to measure the internal diameter of the bearings. By use of an optical measuring head fitted with a telescope the instrument is capable of an accuracy of the order of 0.00002 inch (2×10^{-5} in.) Measurements were made in millimeters and converted to give the diameter in inches to the nearest 10,000th of an inch.

The diameter of the bearing was measured in two directions. Firstly in line with the load application point and secondly at right angles to it (i.e. vertically and horizontally respectively.) While taking the measurements the bearings were checked for parallelism along their length. All specimens were allowed to soak for 24 hours in the temperature-controlled room (26°C) to obviate temperature effects.

During the tests a Mahr internal measuring device, of the type used for inspection purposes, was employed for measuring the bore of the bearings in the vertical and horizontal planes. Owing to the fact that the axis of the bearings under test was not exactly parallel to the loading face of the bearing housing, wear occurred to a greater extent at one end of the bearing bore than at the other. Thus two readings of the vertical diameter, one at each end, were taken during each 2 hourly inspection.

3.2.2. Measurement of Test Journals

The journals were measured on a Carl Zeiss Universal Measuring Machine, Type NR1137. The accuracy obtainable, allowing for operating errors, was of the order of 1/400th millimeter, i.e. 1/10,000th inch.

3.2.3. Measurement of Hardness and Surface Finish

All specimens were tested for hardness on a Vickers Hardness testing machine, and the results are given as Vickers Pyramid Numbers. Plated specimens and surface hardened materials were tested with a sufficiently low load to give consistent readings for two or more impressions. Surface finish was measured on a Taylor Hobson Talysurf Machine and the readings obtained are given in this report in terms of micro-inches, centre line average. Some typical traces of the continuous recorder were taken and these are shown in Figs. 7 to 11

4. Description of Test Rig

4.1. General Descriptions

4.1.1. The Macklow Smith Compression Testing Machine

The test bearing is loaded between a fixed upper platen and a moving platen on which is mounted the bearing assembly and the driving mechanism. The lower platen is raised and kept in place by hydraulic pressure acting on a central ram connected to the platen by tie-rods. Pressure is supplied by a hydraulic pump through a control valve fitted with a bleed cock. The latter was kept partially open during the tests to stabilise the pressure supply. The hydraulic pressure is measured by a swinging arm, fitted with a movable 'poise', and graduated in lbs.

It was found that the equipment mounted on the machine required a pressure equivalent to 320 lbs. load to raise it. Thus during the tests the poise was moved out 320 lbs. further than the tabulated load. Throughout the tests it was possible to keep the actual load between ± 0.5 per cent tabulated load.

4.1.2. The Driving Mechanism

A $\frac{1}{2}$ H.P. 3-phase induction motor, controlled by an over-load breaker switch, drives a speed reducer by pulleys and $\frac{5}{8}$ in. 40° continuous vee belt, 50in. long. The pulley outside diameters are 6.75in. and 7.75in. respectively. The speed reducer ratio is 152.2 : 1. Thus a motor speed of 740 R.P.M. gives a speed reducer input speed of 645 R.P.M. and an output speed of 4.24 R.P.M. The motor and speed reducer are mounted on a platform slung on the supporting structure between two ball bearings. The platform arrangement is described in more detail in 4.2.1. The supporting structure is keyed to the moving platen and bolted so that the output shaft of the speed reducer is in line with the bearing assembly axis. The arrangement is shown in figs. 1 and 2. Some degree of flexibility in the shaft drive is provided by $\frac{3}{16}$ in. hard rubber sheet between the flanges at each end, and by spring washers under the heads of the coupling bolts.

4.1.3. The Bearing Assembly

The test journal is supported on either side by sleeves running in R.M.S. 14 roller bearings. The outer races are fitted in L-shaped support plates keyed and bolted to the platen. The distance between the inner faces of the sleeves, which are a close sliding fit on the journal shaft, is 0.700in. There is thus a clearance of 0.100in. on each side of the bearing bush. Load is applied to the bearing through a housing, shown in fig. 14, on which are secured the thermocouple wires. The number of cycles performed by the journal is recorded on a cycle counter. This counter is operated through a 24 volt circuit by a pair of contacts triggered by an insulated plug on the driving sleeve flange.

4.2. Measurement of Friction in Test Bearing

4.2.1. Measurement of Combined Friction of Test Bearing and Support Roller Bearing

The friction is assessed by continuously measuring the torque required to rotate the driving shaft. The driving mechanism platform is slung between two ball bearings. The output shaft of the gearbox rotates in the front bearing. The rear bearing which is in line with the driving shaft supports the platform through a bracket. As there is only the weight of the platform and equipment mounted on it, and the downward pull of the torque-measuring dynamometer to be reacted by these bearings, their frictional restraint on the platform is negligible. The centre of the dynamometer attachment bolt is a horizontal distance of 10in. $\begin{matrix} +005 \\ -005 \end{matrix}$ from the centre of the driving shaft. The bolt attaching the dynamometer to the fixed structure is vertically below the upper bolt. Thus the dynamometer measures directly the input torque to the bearing assembly; one division of the scale being equal to 20 lb.in.

The coefficient of friction, μ , for the test bearing is calculated as follows:-

$$\begin{aligned} &= \frac{\text{Torque (lb.in.)}}{\text{Bearing Radius } (\frac{1}{2}\text{in.})} \times \frac{1}{\text{Load (lb.)}} \\ &= 2 \times \frac{\text{Torque (lb.in.)}}{\text{Bearing Load (lb.)}} \\ &= 4 \times \frac{\text{Torque (lb.in.)}}{\text{Bearing Pressure (lb/in}^2\text{)}} \end{aligned}$$

where the torque

$$= \text{total input torque} - \text{roller bearing frictional torque.}$$

4.2.2. Calibration of Roller Bearing Frictional Torque

A calibration bearing assembly containing two roller bearings of the same type as the support bearings was set up between them. The photographs of the test rig (figs. 1 - 3) show this assembly in place. The shaft was rotated at normal running speed while the load on the bearings was varied in steps of 5,000 lbs. from 0 - 20,000 lbs. Readings of the dynamometer were taken for each load. The frictional torque of the support bearings was taken as half of the total observed in this test.

Fig. 4, plotted from these readings indicates that the roller bearings exert a restraining torque equivalent to a coefficient of friction of 0.0014. In the tests covered by this report the effect of the roller bearings was neglected for loads up to 10,000 lbs., and for higher loads 10 lb.in. was subtracted from the observed torque; as it was not possible to read the dynamometer to a greater accuracy than 10 lb.in.

4.3. Measurement of Rubbing Speed

The rubbing speed was determined by two methods:-

(a) The input speed of the speed reducer was measured by tachometer. The rotational speed of the journal was then derived by dividing the tachometer speed by 152.2, the ratio of the reducer. The rubbing speed of the bearing surfaces was given by:-

$$\begin{aligned} \text{Rubbing speed} &= \frac{\text{Tachometer R.P.M.} \times \text{Bearing Diameter} \times \pi}{152.2} \\ &= \frac{\text{Tachometer R.P.M.}}{152.2} \times \frac{\pi}{12} \frac{\text{ft.}}{\text{min.}} \\ &= \frac{\text{Tachometer R.P.M.}}{582} \frac{\text{ft.}}{\text{min.}} \end{aligned}$$

(b) The time taken for the journal to complete 240 revolutions was measured and the rotational speed calculated from this value.

The two methods were used to check each other.

It was found throughout the tests that the speed reducer input varied by only ± 5 about 645 R.P.M. Thus the rubbing speed varied between 1.10 $\frac{\text{ft.}}{\text{min.}}$ and 1.12 $\frac{\text{ft.}}{\text{min.}}$. For purposes of comparison with other bearing applications the rubbing speed is taken as 1.10 ft./min.

4.4. Measurement of Test Bearing Temperature

The temperature was measured by a thermocouple which consists of two wires, copper and constantan, joined together at one end in a solder plug fitting into a hole in the bearing just above the contact area.

The thermocouple was calibrated in clear water and was found to be sufficiently sensitive to give readings to the nearest 0.5°C.

It is to be noted that the thermocouple does not measure the temperature at the rubbing surface but at some distance away from it. Thus its main purpose is to indicate temperature variation, although it does give some indication of the temperature that might be expected in practice from continuous running.

5. Description of Test Specimens

5.1. Journals

5.1.1. General Description

All journals were made to the dimensions shown in fig. 12. Maching operations were carried out in the College workshops and

special processes were performed by outside contractors. Solid drawn bar was used in all three cases. The specimens were first turned to 1.016in. diameter. The bolt holes were then bored and reamed, using a special jig. The remaining operations were carried out for the different materials as follows.-

(a) S.82, 85-ton steel, case-hardened. The steel was case-hardened to a depth of 0.030in. and then ground and polished to the finished size from 1.016in. diameter.

(b) D.T.D. 317, Nitrided. The specimen was turned to 1.004in. diameter, nitrided and finally ground and polished to size.

(c) S.90 Chromium-plated. The shaft was ground to 0.997in. diameter and hard chromium-plated to a depth of 0.003in. The plating was then ground and polished to leave a thickness of 0.001in.

5.1.2. Surface Finish and Hardness

The surface finish achieved by grinding and polishing was practically uniform over the whole range of specimens, varying from 5 - 9 micro-inches, centre line average. The hardness of the specimens in each material was also found to be uniform. Hardness measurements were taken on an area adjacent to the rubbing area, and a sufficiently low load was used on the Vickers Hardness Machine to prevent penetration of the hardened or plated surface.

5.2. Bearings

5.2.1. General Description

All bearings were made with the overall dimensions shown in fig. 13 to fit in the 2in. hole of the bearing housing and to fit the journals with a clearance of between 0.0005in. and 0.0015in. The internal surface was ground and lapped to the highest surface finish possible except where otherwise stated in the following notes.

Two main types of bearing were made. Bearings of materials with sufficient mechanical strength were made in one piece to the finished sizes. The other bearing materials were made as bushes and press-fitted into mild steel outer bushes. The standard wrapped bushes supplied by Glacier Metal Company were also press-fitted into mild steel bearings. Details of the bearings were as follows.-

(a) Hidurax I, Hidurax Special, Hidurel 5, and Grey Cast Iron.

These bearings were machined from the solid and fitted with a grease groove and thermocouple hole as shown in the drawing, fig. 13 .

studying the design of bearings for various applications. For high pressures under hydrodynamic conditions (i.e. for about 4,000 lb.in.²) the L/D ratio should be between 0.5 and 0.8. Bearings for lower pressure applications with steady unilateral loading and continuous oil lubrications may have L/D ratios as high as 1.5. Under the pressures used in these experiments, however, oil lubrication is not sufficient. Boundary conditions of lubrication exist and an extreme pressure additive grease is required. Thus considerations of oil film pressure generation are superfluous. Bending effects become more important. It was considered that with an L/D ratio of 0.5 on a 1in. diameter bearing the latter would be very small. Further reduction of the L/D ratio was decided against because, firstly, the bearing would not have sufficient lateral support and, secondly, the aim is to establish suitable bearings with as small an overall diameter as possible, whilst the bearing pressure is limited.

6. Results

6.1. Arrangement of Results

The values of friction, bearing temperature and wear observed during the tests are shown graphically in Appendix IV. Details of surface finish, hardness, lubrication, and appearance of the rubbing surfaces at intervals during the tests accompany the graphs in Appendix IV.

The figures and the table are arranged in the same order as the tests to facilitate comparison.

An abstract of the results is given in Table I. This Table should be consulted if the reference number of a test is required.

7. Analysis of Results

7.1. Comparison of Results

All the tests covered by this report were made on continuously rotating shafts in a bearing housing more rigid than most practical bearing housings. The effects of oscillating motion and lack of rigidity are discussed in 8. The loading surface of the bearing housing was not exactly parallel to the axis of the bearings, so that in each test it was possible to observe the extent of deformation and wear of the bearing after every 480 cycles. The mean increase of vertical diameter of the bearing is recorded in the results.

It is to be noted that in practically all cases marking of the journal and bearing occurred. It appears to be no cause for concern. The bearing performance was certainly not impaired by a moderate amount of pick-up and light scoring. It was only when heavy scoring or pitting, and pick-up of the order of 0.003in. occurred that the bearing began to fail.

Hidurax Special on a chromium-plated journal (Test 1) gave the best performance over the whole range of pressures. The wear was very low and the coefficient of friction was only greater than 0.10 at the beginning when the surface finish was rather rough. See Fig. . The surface quickly became polished to about 30 micro-inches C.L.A. The high friction may also have been due to the time lag in the reaction of the lubricant additive with the hidurax surface. The use of Hidurax Special with plain hardened steel is not to be recommended. Test 6 shows a considerable variation in friction, indicating tearing of the surfaces and breakdown of boundary lubrication which was probably due to the iron constituent of the Hidurax Special bronze welding to the journal steel. Figs. 5 and 6 show the appearance of the materials after test; the effects are not very clearly defined. Fig. 7 however, indicates that scoring of over 0.001in. of the hidurax occurred with the nitrided shaft whereas the chromium-plated shaft had a polishing effect on the bearing material.

Ferobestos LF with a nitrided journal (Test 5) proved very effective up to 20,000 lb/in². The coefficient of friction was very steady and did not exceed 0.08. Some wear took place but if this should be unimportant the bearing has attractive possibilities. Only grease was used to lubricate it but molybdenum disulphide or graphite may well improve its performance further.

Grey Cast Iron on a Chromium-plated journal (Test 2) gave very steady results. The coefficient of friction did not exceed 0.140 except at the beginning of the test, and the amount of wear was not excessive. This combination may well prove attractive where cost is a consideration. The cast iron and nitrided steel combination (Test 7) proved to be unreliable. Seizure eventually occurred when a piece of cast iron welded to the steel. This combination indicated the inadvisability of running together two materials with the same main constituent. The photographs in Figs. 5 and 6 show the appearance of the journals and bearings after test. Heavy scoring of bearing CI2 (N5) has occurred whereas CI1 (P3) is polished. The photographs of journal P3 and N5 do not show the very real difference in their surfaces. In fact, a piece of cast iron is welded to the journal N5, while the marking on P3 is no more than a colouring of the grinding grooves.

Tin-plated Steel on chromium-plating (Test 8) gave a low coefficient of friction on starting which rose to a maximum value of 0.11 in the tests up to 20,000 lb/in². Towards the end of the test the friction varied considerably probably because the plating was wearing very thin and adhesion between the journal and the underlying steel was occurring.

A thicker coating of tin, say 0.001in, may give very good results for pressures up to 30,000 lb/in.² The use of a thin layer of soft material on steel keeps the increase in clearance to a minimum.

Cadmium-plated steel on both chromium-plating and case-

hardened steel journals (Tests 10 and 14) was unsatisfactory. The cadmium was very quickly peeled from the surface as is shown by the graphs of the friction for these two tests. The coefficient of friction rose to 0.35 and then fell, presumably as the lubricant reacted with the newly-bared steel surface. Other plated materials, lead and zinc, remain to be tested. These might give good results.

Hidurel 5 on Nitrided steel (Test 3) gave results similar to those for cast iron on chromium-plated steel except that there was rather more wear. A deposit of Hidurel on the nitrided steel appears similar to the deposit of Hidurax Special on a similar nitrided journal. See Figs. 10 and 11.

Sintered Materials of various types were tested. The Glacier Standard Wrapped Copper-Lead bearing gave a coefficient of friction of about 0.13, when used with XG 345, which compares favourably with the other materials tested. The amount of wear observed, however, precludes its use for bearing pressures of greater than about 4,000 lb/in² for which it was designed. Three tests (Tests 15, 16 and 17) were carried out with these bearings to determine the effects of lubrication. The use of a grease without extreme pressure additives (DED 577) gave a higher and more erratic coefficient of friction, indicating that extreme pressure additive greases are necessary for these high pressures. The increase in lubrication period for this combination, however, appeared to have little effect. It is interesting to note that despite the difference in friction the wear of the bearings in these three tests was almost identical. Thus the whole series of tests would appear to be repeatable and values of wear may be used for design purposes.

Sintered Bronze on Case-hardened steel (Tests 11 and 12) showed a considerable increase in diameter due to insufficient strength. The coefficient of friction was also very high. The surface of the journal, although marked with bronze was very little affected. See Fig. 8. The bearing, however, was polished to some extent.

Sintered Alloy Iron on Chromium-plated steel (Test 13) gave results which differ considerably from those of any other materials. The starting friction was high but once lubrication was operating effectively the coefficient of friction fell to about 0.5. It is thought that this material impregnated with P.T.F.E. may well prove very successful up to 20,000 lb/in².

Sintered Stainless Steel on nitrided steel proved to have insufficient strength. It is interesting to note that the surface of the journal was considerably smoother after test. See Fig. 10.

P.T.F.E.-impregnated Sintered Bronze was used unlubricated on case-hardened steel and lubricated on nitrided steel (Tests 4 and 18). P.T.F.E. is a slippery white plastic of very low strength. The sintered bronze was therefore intended to provide the necessary strength. It would appear from these tests, however, that the bronze was not sufficiently strong, because the wear, even when the bearing was lubricated, was quite considerable.

Chromium-plating on the journal appears to reduce the wear and friction in bearings which are capable of retaining the lubricant on their surface. In all the cases tested it proved better to use chromium-plating than a plain hardened steel. It may not however prove suitable in all cases. The depth of plating (0.001in.) proved to be satisfactory.

There appears to be little difference between the effects of case-hardened and nitrided steel. Either may be used where plain steel is suitable.

The degree of surface finish on the softer material appears to be unimportant. Friction is only affected in the early stages and the amount of surface damage is not altered. It is however more important that the journal finish should be as good as possible. Irregularities in the surface appear to behave to some extent like cutting tools and the greater they are the more will be the wear.

7.2. Indication of Further Suitable Materials

The useful results obtained from Hidurax Special on Chromium-plating and Hidurel 5 on nitrided steel indicate that Hidurax I may be used with some success. Hidurel 5 on chromium-plating should also be tested.

A self-lubricating bearing is required. This need may well be filled by the use of molybdenum disulphide or P.T.F.E. It was hoped to carry out tests on steel bearings lined with MoS₂, as described in 5.2.1, but these were not available in time. The tests carried out on P.T.F.E.-impregnated bronze were not very successful. It is considered, however, that if a stronger bronze were used, P.T.F.E. might be a very good lubricant at these pressures.

A soft material plated on steel should give good results if it is possible to bond it strongly to the steel backing. Tin on steel performed satisfactorily and so may lead and zinc, although their life may be rather limited.

8. Conclusions

The tests covered by this report have established certain bearing combinations of length-diameter ratio 0.5, as suitable for use at pressures up to 40,000 lb/in². and rubbing speeds up to 1.1 ft/min. However, the friction and wear of practical bearings will probably not be the same as those recorded in this report. Lack of rigidity of the bearing housing will give rise to higher coefficients of friction. Wrong clearances may also increase the friction. A Newall Z fit in an 'A' hole giving a clearance of between 0.00050in. and 0.00175in on a 1 inch shaft is recommended.

Insufficient data has been collected to calculate accurately the life of a bearing from the results. Oscillatory

motion will, of course, cause the pick-up on the journal to build up more rapidly and thus the life of the bearing may be shortened. Oscillatory motion may also make good lubrication more difficult to achieve. These factors, however, will not affect the choice of bearing materials for a given application.

There was, in general, no great variation in wear with change in load. It is suggested therefore, until further data are available, that for most aircraft applications the amount of wear per 1,000 feet of distance traversed by one surface over the other, will give some idea of the increase in clearance to be expected.

The following table includes all the bearings found suitable for use when lubricated with XG 345 every 64 feet of distance traversed.

<u>Bearing Material</u>	<u>Journal Material</u>	<u>Wear per 1,000 ft</u>	<u>Coefficient of Friction</u>
Hidurax Special	S.90 Chromium-plated	0.0006in.	0.10
Grey Cast Iron	'	0.0018in.	0.135
Hidurel 5	DTD 317 Nitrided	0.0030in.	0.140

The above bearing combinations may be used for pressures up to 40,000 lb/in².

<u>Bearing Material</u>	<u>Journal Material</u>	<u>Wear per 1,000 ft</u>	<u>Coefficient of Friction</u>
P.T.F.E. and Bronze	DTD 317 Nitrided	0.0040in.	0.10
Ferobestos LF	'	0.0048in.	0.08

The above two bearing combinations must not be used at pressures above 20,000 lb/in².

TABLE I Abstract of Results

Test No.	Bearing Material	Journal Material	Lubrication	Max. Bearing Pressure (lb/in ²)	Coefficient of friction	Wear per 1,000ft. (inches)
1	Hidurax Special	S.90 Chromium-plated	DTD 844	40,000	0.10	0.0006
2	Grey Cast Iron	' ' '	DTD 844	40,000	0.135	0.0018
3	Hidurel 5	DTD 317 Nitrided	DTD 844	40,000	0.14	0.0030
4	P.T.F.E. Bronze	' ' '	DTD 844	20,000	0.10	0.0040
5	Ferobestos 'LF'	' ' '	DTD 844	20,000	0.08	0.0048
6	Hidurax Special	' ' '	DTD 844	40,000	0.215	0.0054
7	Grey Cast Iron	' ' '	DTD 844	40,000	0.24	Scized
8	Tin-plated Steel	S.90 Chromium-plated	DTD 844	30,000	0.135	Un-plated
9	Sintered Stainless Steel	DTD 317 Nitrided	DTD 844	10,000	0.28	Yielded
10	Cadmium-plated Steel	S.90 Chromium-plated	DTD 844	10,000	0.34	Un-plated
11	Sintered Bronze	S.82 Case-hardened	DTD 844 ^x	20,000	0.26	Yielded
12	' ' '	' ' '	DTD 844	20,000	0.23	Yielded
13	Sintered Alloy Iron	S.90 Chromium-plated	DTD 844	30,000	0.24	Yielded
14	Cadmium-plated Steel	S.82 Case-hardened	DTD 844	10,000	0.32	Un-plated
15	Standard Wrapped Cu-Pb	' ' '	DTD 844	20,000	0.13	0.0104
16	' ' '	' ' '	DTD 577	20,000	0.24	0.0108
17	' ' '	' ' '	DTD 844 ^x	20,000	0.13	0.0096
18	P.T.F.E. Bronze	' ' '	None	20,000	0.165	0.0116

^xLubrication every 480 cycles (128 ft. distance traversed). In all other cases every 240 cycles.

Appendix I

Notes on the Friction and
Wear of Bearing Materials

The actual area of contact between two metal surfaces held together is, in general, much smaller than the apparent area of contact. However carefully the metal surfaces are machined their roughness is considerable in terms of molecular dimensions. (See Figs. 7 to 11). When two surfaces are brought together the asperities of one surface come into contact with those of the other, and yielding of the material of the asperities occurs until sufficient area of contact exists to support the load. The area of contact is proportional to the load in most practical cases and is given by

$$A = \frac{1}{p_m} W \quad (\text{Bowden and Tabar, 1950})$$

where p_m is the mean yield pressure of the asperities.

When the two surfaces are moved relative to each other, metallic junctions are formed and sheared and also some ploughing of the softer material by the harder one occurs. The frictional force is that required to move the surfaces against these resisting forces. The shearing and ploughing also produces wear which may occur in any one of four ways. If the metal junction formed is weaker than either of the bearing materials shearing will occur at the interface between the two metals and little wear will result. Secondly, if the junction is stronger than either of the metals, shearing will occur in the weaker metal and there will be considerable wear of the softer material. There may also be the case where shearing occurs to some extent in the stronger metal as well as in the weaker one. Finally, in the case of similar metals work-hardening of the junctions will cause the basic material to shear and heavy surface damage will result.

In practice, however, most metals are covered by a very thin oxide film which although torn during sliding reduces the inter-metallic contact considerably and thus reduces the friction and wear. The use of a lubricant also reduces wear. In the tests covered by this report pure hydrodynamic lubrication, i.e. the formation of a lubricant film of sufficient pressure and thickness to prevent contact between the surfaces, did not exist. The main effect of the lubricant was to produce boundary lubrication at the asperities although some hydrodynamic lubrication of the depressions between may have existed. The extreme pressure additives in the lubricant produce the boundary lubrication. They may be either fatty acids or other materials which react with the metallic surfaces to produce low shear strength films. Fatty acids, for example, react with metals to produce soaps which are strongly bonded to the surface. Other additives may be compounds which react with the surface to form sulphides.

Friction and wear are not directly related. If shearing occurs at the inter-face between two metals wear will obviously not

be as considerable as when shearing occurs in the body of one of the materials, although the force required to produce the shearing may be the same in both cases. Nor is wear necessarily related to load although in general it should increase with load. It has been shown by Bowden and Tabor however, that wear is directly proportional to the distance travelled by one material over another under given load conditions. In practice, several variables such as temperature and humidity, affect the amount of wear, and the measurements of wear made during the tests may not be reproducible. Despite this probable variation of wear under different conditions it is considered that as the conditions of testing were fairly typical of good aircraft practice, the values of wear observed should give a good indication to the designer of the life he may expect from his bearings.

Appendix II

Notes on the Choice of Materials and Lubricants for Tests

It was decided at the outset that the journals would be of harder materials than any of the bearings. The reasons were as follows: At very high loads considerable bending stresses are induced in the shaft whereas only compressive stresses are induced in the bearing. Thus from considerations of both weight and bearing surface distortion it is preferable to have the stronger material as the shaft. Also, it was expected that the wear of the soft material would show more clearly if it was used for the uni-laterally loading bearing and not the revolving shaft. This last was also the reason for not adopting soft surface finishes (such as tin) on the journal.

Three types of journal were used; nitrided steel, case-hardened steel and steel hard chromium-plated to a depth of 0.001in. Their surfaces were made as hard as possible to produce a large difference in hardness between the bearing and the journal. The case-hardened and chromium-plated steels were of the required hardness, but the hardness of the nitrided steel was lower than expected. This appeared to be due to a very small depth of penetration of the nitriding. However, the journals were satisfactory for these tests and it does not appear necessary to require a depth of nitriding of more than about 0.010in.

The Bearing materials were chosen to give as wide a cross-section of the available materials as possible, which could be tested in the time available. Some of the materials listed in 5.2.1. were not forthcoming, but the tests carried out were sufficient to indicate the behaviour of all except the MoS₂-coated bearings. It is realised that other materials such as the Vandervell thin-wall bearing tested by the English Electric Co. (Test Notes: 134 and 168) and the Fairey Aviation Company, have been found suitable for high pressure applications, and it is suggested that these materials should form the subject of future tests.

Aeroshell Grease XG 345 to specification DTD 844 was used in all tests except Test 13 when Aeroshell Grease 4 (DTD 577) was used for determination of the effects of the extreme pressure additive in the grease XG 345. Grease to DTD 844 was chosen in preference to Aeroshell Grease 11 to specification DTD 825, because it is cheaper and has higher load carrying capacity. It is to be noted that this grease contains a synthetic oil and should therefore not come into contact with certain synthetic rubbers. It also has a lower melting point (325°F. as opposed to 378°F. for DTD 825) and thus may not prove suitable for very high speed applications.

See Aeroshell Handbook for further details.

Appendix III

Notes on the Appearance of Some Journals after Test

The marked area of each journal was examined under a Binomax dual-eyepiece microscope. There appeared to be three distinct types of marking. On the case-hardened and nitrided shafts a finely divided and discontinuous layer of the bearing material was smeared over light blue areas of steel. It would thus appear that welding occurred between the bearing and the steel when at a high temperature.

The surfaces of the steel journal which had been running in the Ferobestos bush appeared similar to the unmarked steel surface except that it was coloured light blue and straw. These colours were so intermingled that to the naked eye the shaft appears to be marked with neutral-grey lines. It was apparent that no Ferobestos had been transferred to the journal; that only surface heating had occurred.

The appearance of the chromium-plated shaft which had been running in the cast iron bearing was very similar to that of the shaft used with the Hidurax Special bearing, both under the microscope and to the naked eye. A dark neutral-grey material appeared to be interspersed in very small quantities in the grooves of the ground surface. Between the dark material particles the surface of the chromium shone brightly. There was some variation in intensity and sharpness of the marking but its colour and microscopic formation were very similar.

The effect was proved not to be due to the grease by revolving a chromium-plated shaft at high speed in a lathe whilst a Hidurax Special surface was held against it. The shaft was lubricated with XG 345 for one run and degreased for the other. There was no difference in the markings, which were similar to those obtained under the normal test conditions.

An attempt was made to determine the composition of the marking for the Hidurax Special combination by using the B.D.H. Spot-Test Outfit. Concentrated sulphuric acid was placed on the

shaft over a marked and an unmarked area, and allowed to react with the surface for 10 minutes. The drops were then carefully removed and placed in test-tubes where they were made alkaline by adding potassium hydroxide solution. Drops of an aqueous solution of sodium diethyl-dithio-carbamate were added. It was observed that the solution acquired a temporary white turbidity for the marked area of the shaft but not for the plain chromium-plating. A further test was carried out with a Hidurax Special bearing and the temporary white turbidity again appeared. An alkaline solution of sulphuric acid and potassium hydroxide produced no turbidity.

It is stated in the B.D.H. Book of Organic Reagents,-
'Iron produces a brown colour with the reagent, while aluminium, antimony, bismuth, cadmium, lead, mercury, tin, and zinc yield white turbidites.'

It would appear from the above that the marking on the shaft is not chromium or compound of chromium, but some constituent of the bearing material. This test was certainly not conclusive, however, and further research is necessary before the nature of the markings can be clearly defined.

Appendix IV

Details of Bearing Combinations Tested and
Remarks on their appearance at intervals
throughout the Tests

TEST 1

Bearing: No. H S 3 Hidurax Special
Surface Finish: 40 micro-inches, C.L.A. Hardness: 240 V.P.N.

Journal: No. P 1 S.90 Chromium-plated
Surface Finish: 6 micro-inches, C.L.A. Hardness: 460 V.P.N.

Initial Clearance: 0.0006in. Lubrication: XG 345 every 240 cycles.

Notes on Appearance of Rubbing Surfaces

After 480 cycles: Journal darkened over half of bearing width. Corresponding polished surface on bearing for 1/3 circumference.

After 960 cycles: Darkening of journal slightly heavier and wider. Bearing polished over greater width but grinding marks still showing. Grease blackened.

After 1440 cycles: Journal darkened over almost whole width of bearing - grease blackened. Grinding marks almost obliterated.

After 1920 cycles: Under the microscope the darkening of the journal appears to be due to a material in the grooves made by grinding. Bearing polished over half circumference. Surface roughness 20 micro-inches. The markings on the shaft appear to be a fine deposit of hidurax. See Appendix III.

TEST 2

Bearing: No. C I 1 Grey Cast Iron
Surface Finish: 24 micro-inches, C.L.A. Hardness: 230 V.P.N.

Journal: No. P 3 S.90 Chromium-plated
Surface Finish: 7 micro-inches, C.L.A. Hardness: 470 V.P.N.

Initial Clearance: 0.0008in. Lubrication: XG 345 every 240 cycles.

Notes on Appearance of Rubbing Surfaces

After 480 cycles: Darkening of shaft over width of bearing, varying in intensity from one side to the other. Dark circumferential marks on bearing but no scoring.

After 960 cycles: Journal appearance unchanged. Bearing polished over 1/4 circumference.

After 1440 cycles: Marking on journal almost uniform grey. Bearing streaked circumferentially with dark lines.

After 1920 cycles: Appearance similar to that after 1440 cycles.

Grease blackened throughout test. The markings on the shaft appear to be a very fine deposit of iron. See Appendix III.

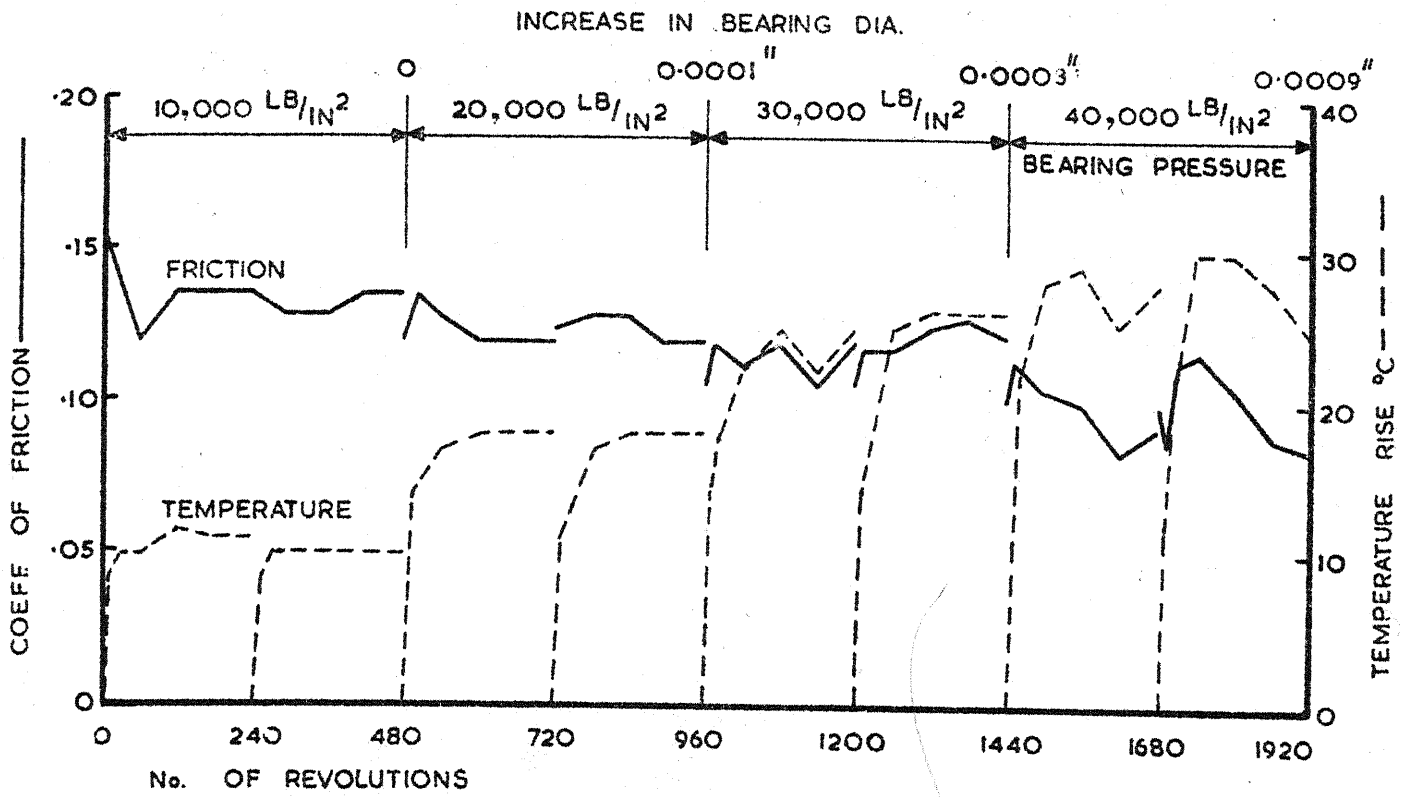
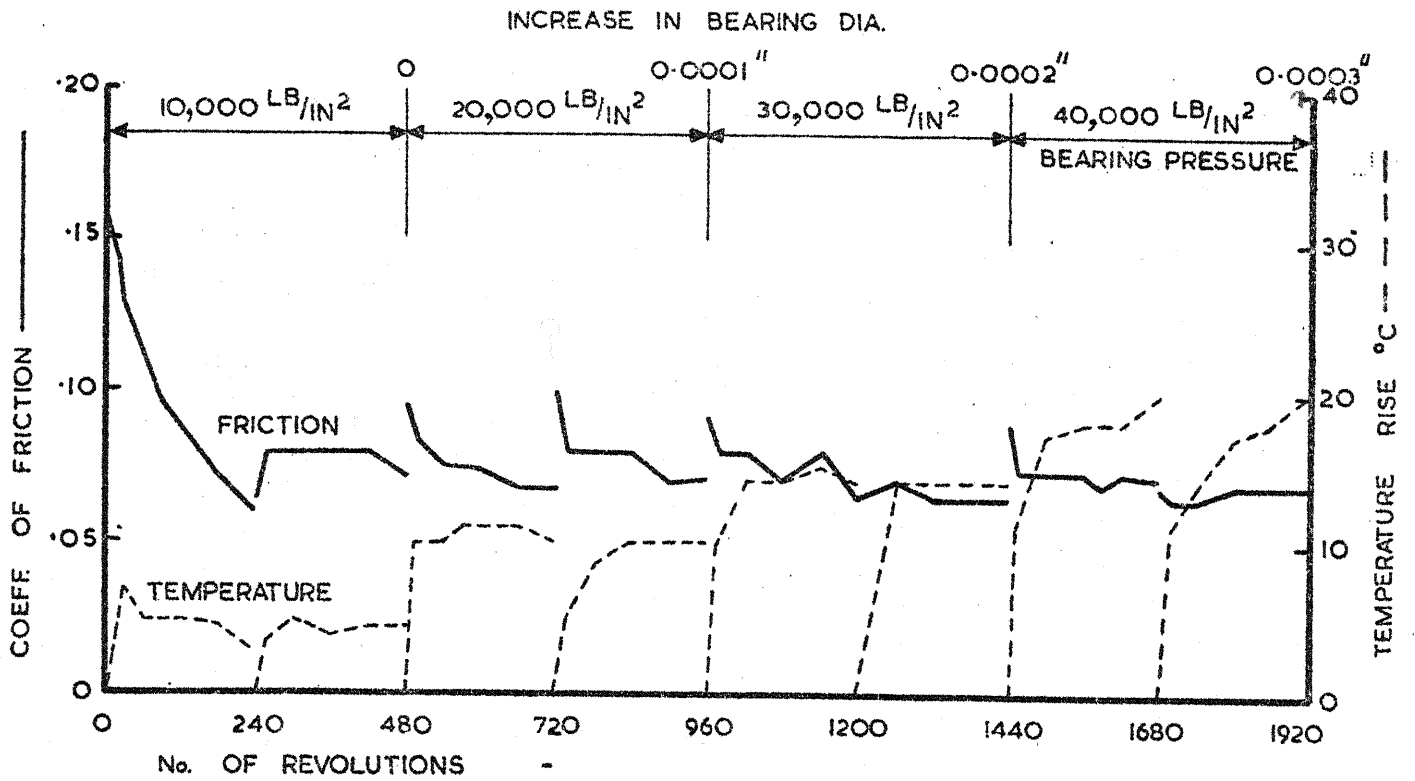

TEST 3

Bearing: No. H B 5 Hidurel 5
Surface Finish: 13 micro-inches, C.L.A. Hardness: 205 V.P.N.
Journal: No. N 3 DTD 317 Nitrided
Surface Finish: 7 micro-inches, C.L.A. Hardness: 760 V.P.N.
Initial Clearance: 0.0007in. Lubrication: XG 345 every 240 cycles.

Notes on Appearance of Rubbing Surfaces

After 480 cycles: Bearing polished over $1/3$ circumference and $3/4$ width. Very light scores on journal.

After 960 cycles: Bearing polished over entire width and $1/3$ circumference. Scores on journal over width of bearing and slightly heavier than before.

After 1440 cycles: Small particles of bronze distributed through grease. Journal and bearing appearance as after 960 cycles.

After 1920 cycles: Bearing worn over nearly $1/2$ circumference. Journal scoring heavier but still not very considerable. More particles of bronze in grease than before.

TEST 4

Bearing: No. T E 1 Sintered Bronze and P.T.F.E.
Surface Finish: 60 micro-inches, C.L.A.
Journal: No. N 17 D.T.D. 317 Nitrided
Surface Finish: 7 micro-inches, C.L.A. Hardness: 820 V.P.N.
Initial Clearance: 0.0006in. Lubrication: XG 345 every 240 cycles.

Notes on Appearance of Rubbing Surfaces

After 480 cycles: Light smear of bronze on journal. Bearing polished over $1/2$ width and $1/3$ circumference.

After 960 cycles: Bearing polished over $3/4$ width and $1/3$ circumference. Continuous smear of bronze on journal over $1/2$ bearing width.

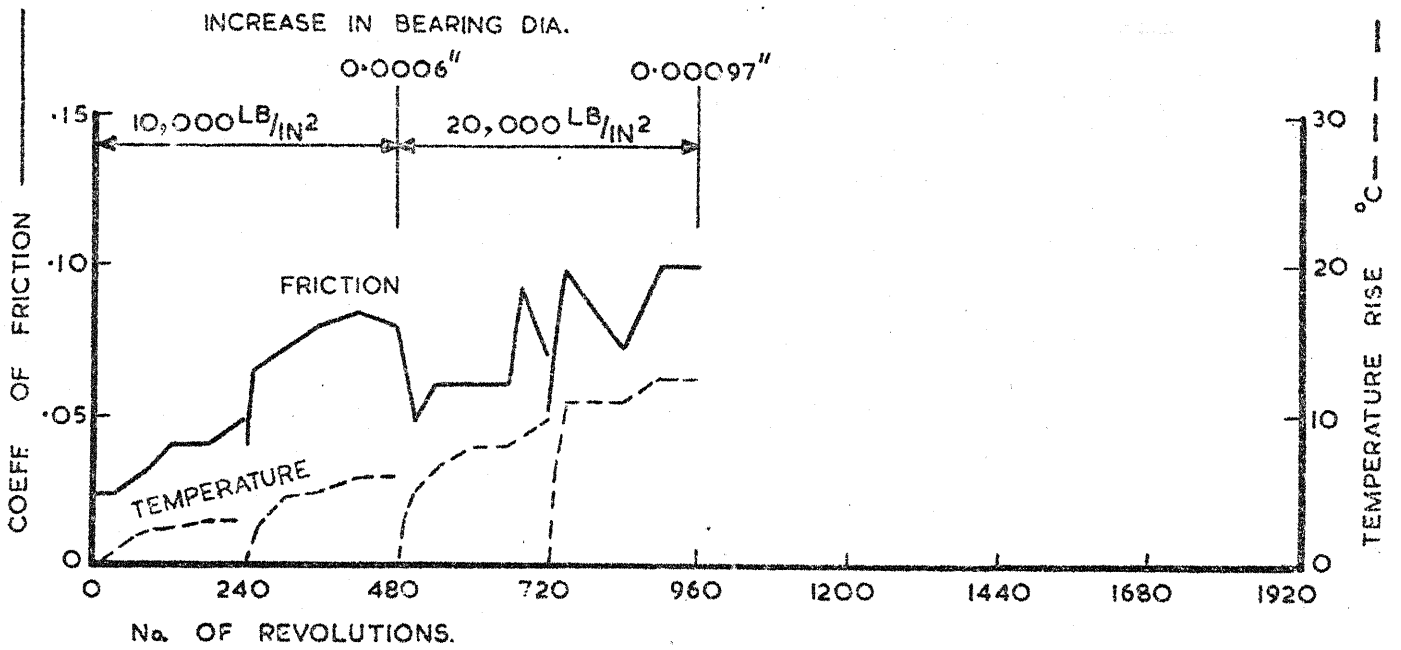
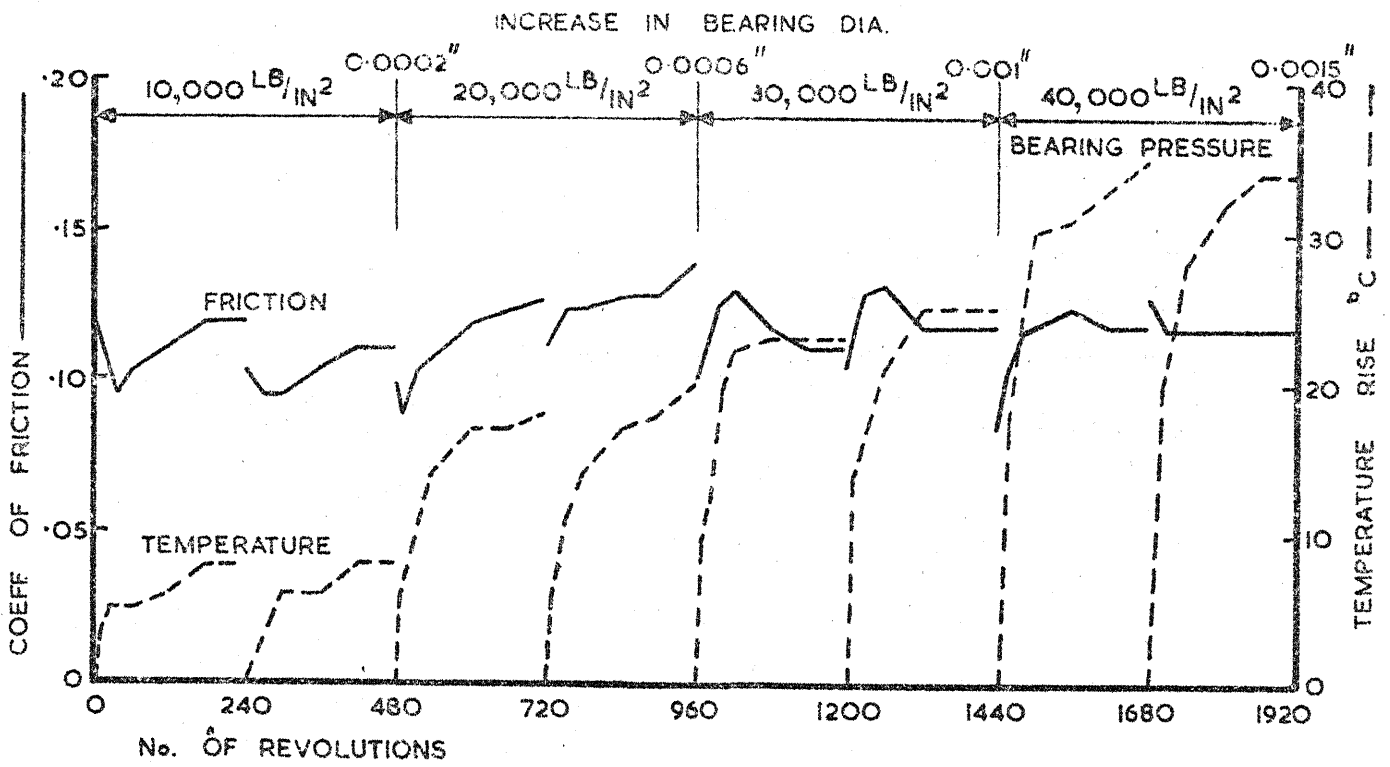

TEST 5

Bearing: No. L F Ferobestos L F Plastic
Surface Finish: 18 micro-inches, C.L.A. Hardness: not measured
Journal: No. N 1 D.T.D. 317 Nitrided
Surface Finish: 7 micro-inches, C.L.A. Hardness: 760 V.P.N.
Initial Clearance: 0.0005in. Lubrication: XG 345 every 240 cycles.

Notes on Appearance of Rubbing Surfaces

After 480 cycles: Very slight circumferential scores on journal. Ferobestos bush almost dry but otherwise appearance unchanged.

After 960 cycles: Still very slight scores on journal. Ferobestos polished and not visibly worn. Bush had not rotated in mild steel housing.

After 1017 cycles: Bearing failed. Plastic disintegrated into flakes with yellow dusty appearance. 2/3 of bush remaining in original condition. Bush had rotated just prior to failure.

TEST 6

Bearing: No. H S 4 Hidurax Special
Surface Finish: 16 micro-inches, C.L.A. Hardness: 240 V.P.N.
Journal: No. N 4 D.T.D. 317 Nitrided
Surface Finish: 6 micro-inches, C.L.A. Hardness: 760 V.P.N.
Initial Clearance: 0.0006in. Lubrication: XG 345 every 240 cycles.

Notes on Appearance of Rubbing Surfaces

After 480 cycles: Very light marks on journal. Small amount of scoring and polishing of bearing over 3/4 width and 1/3 circumference.

After 960 cycles: Journal marked over bearing width. One line of continuous hidurax deposit. Bearing polished with dark striations on the surface.

After 1440 cycles: Several lines of hidurax deposit on journal. Grease blackened considerably. Bearing marked over 1/2 circumference.

After 1920 cycles: Pick-up of bronze on journal increased from before. Bearing polished and marked with dark lines.

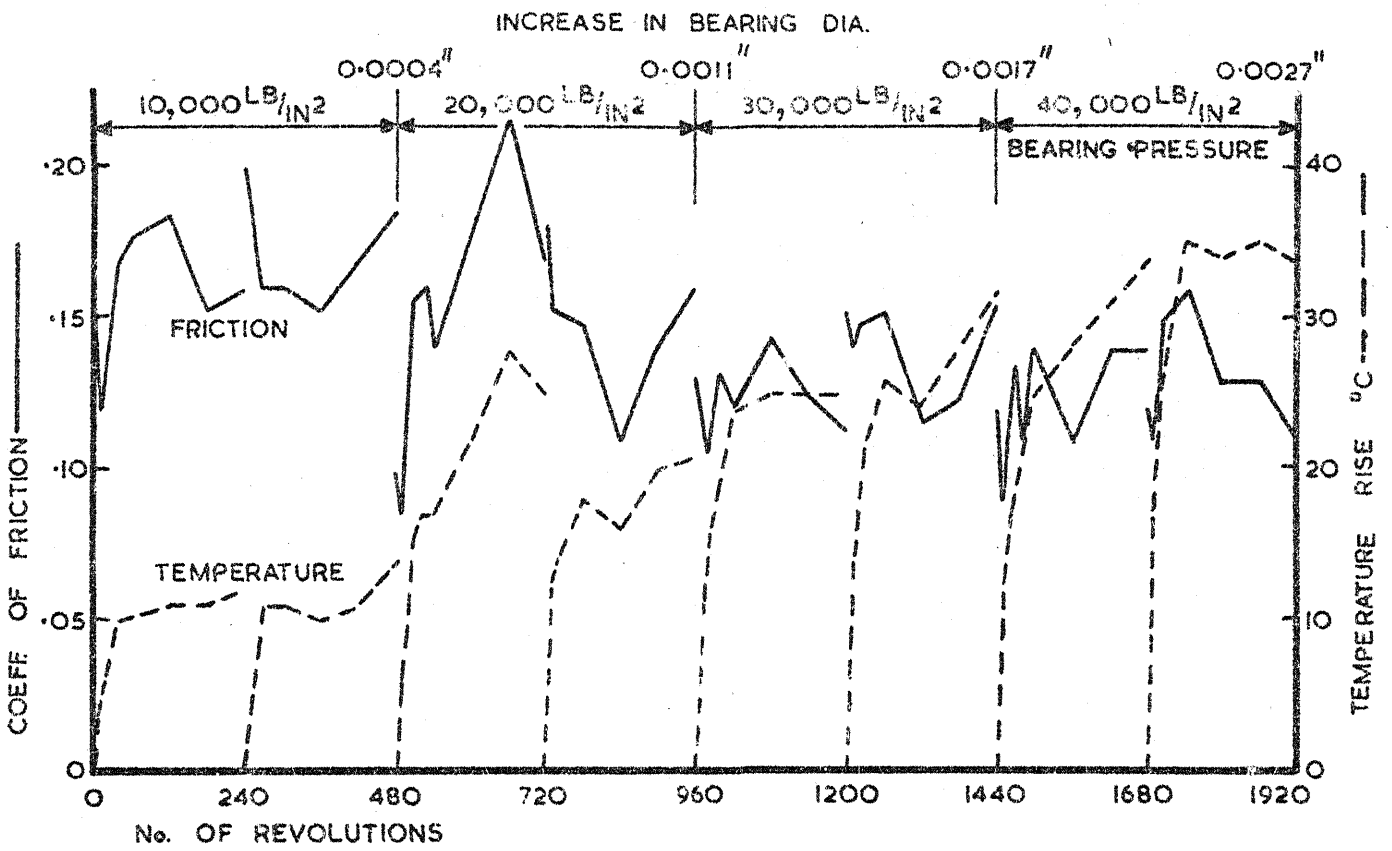
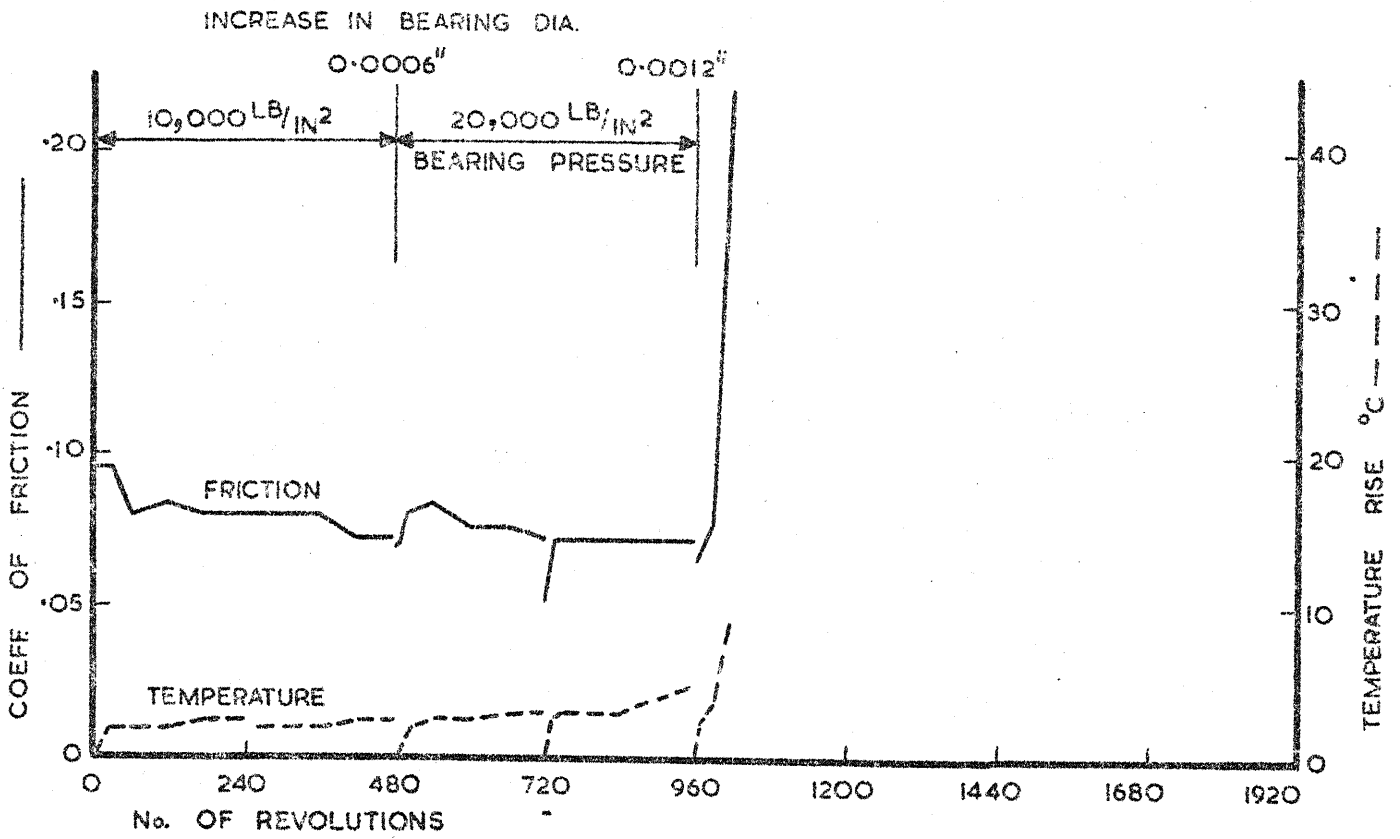

TEST 7

Bearing: No. C I 2 Grey Cast Iron
Surface Finish: 24 micro-inches, C.L.A. Hardness: 210 V.P.N.
Journal: No. N 5 D.T.D. 317 Nitrided
Surface Finish: 7 micro-inches, C.L.A. Hardness: 760 V.P.N.
Initial Clearance: 0.0009in. Lubrication: XG 345 every 240 cycles.

Notes on Appearance of Rubbing Surfaces

After 480 cycles: Very light polishing marks on journal. Bearing appearance unchanged.

After 960 cycles: Journal marking rather heavier but bearing surface still as ground.

After 1440 cycles: Journal marked over bearing width. A few dark lines on cast iron surface.

After 1670 cycles: Bearing seized. Pieces of cast iron torn away from bearing and welded to the journal.

TEST 8

Bearing: No. S N 1 Tin-plated Steel
Surface Finish: 50 micro-inches, C.L.A.
Journal: No. P 5 S.90 Chromium-plated
Surface Finish: 6 micro-inches, C.L.A. Hardness, 470 V.P.N.
Initial Clearance: 0.0014in. Lubrication: XG 345 every 240 cycles.

Notes on Appearance of Rubbing Surfaces

After 480 cycles: Journal and bearing marked with a brown tinted dark material, over $\frac{1}{2}$ bearing width.

After 960 cycles: Grease thoroughly blackened. Bearing and journal marked with same material as after 480 cycles but more intensely.

After 1440 cycles: Appearance of both bearing and journal as above but whole width and $\frac{1}{2}$ circumference affected. Surface roughness of bearing now 3 micro-inches, C.L.A.

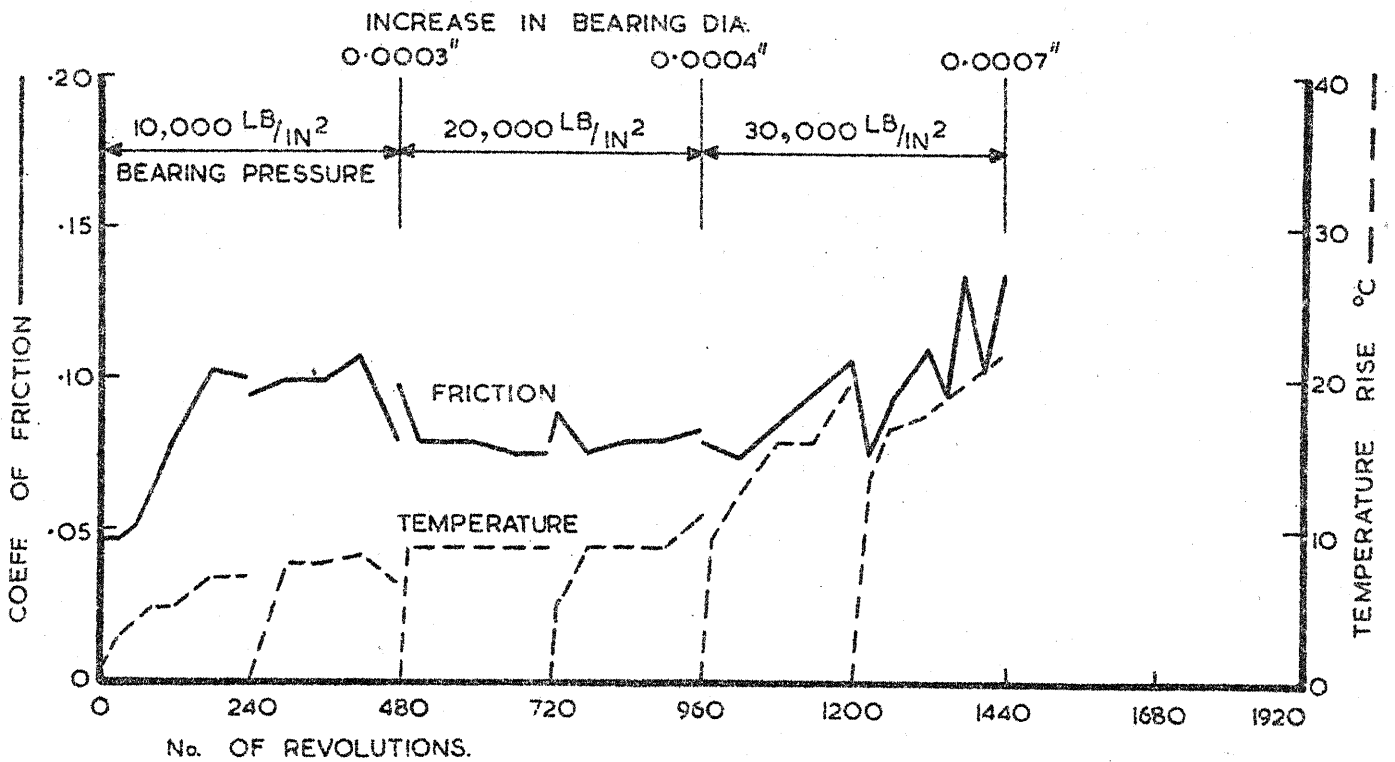
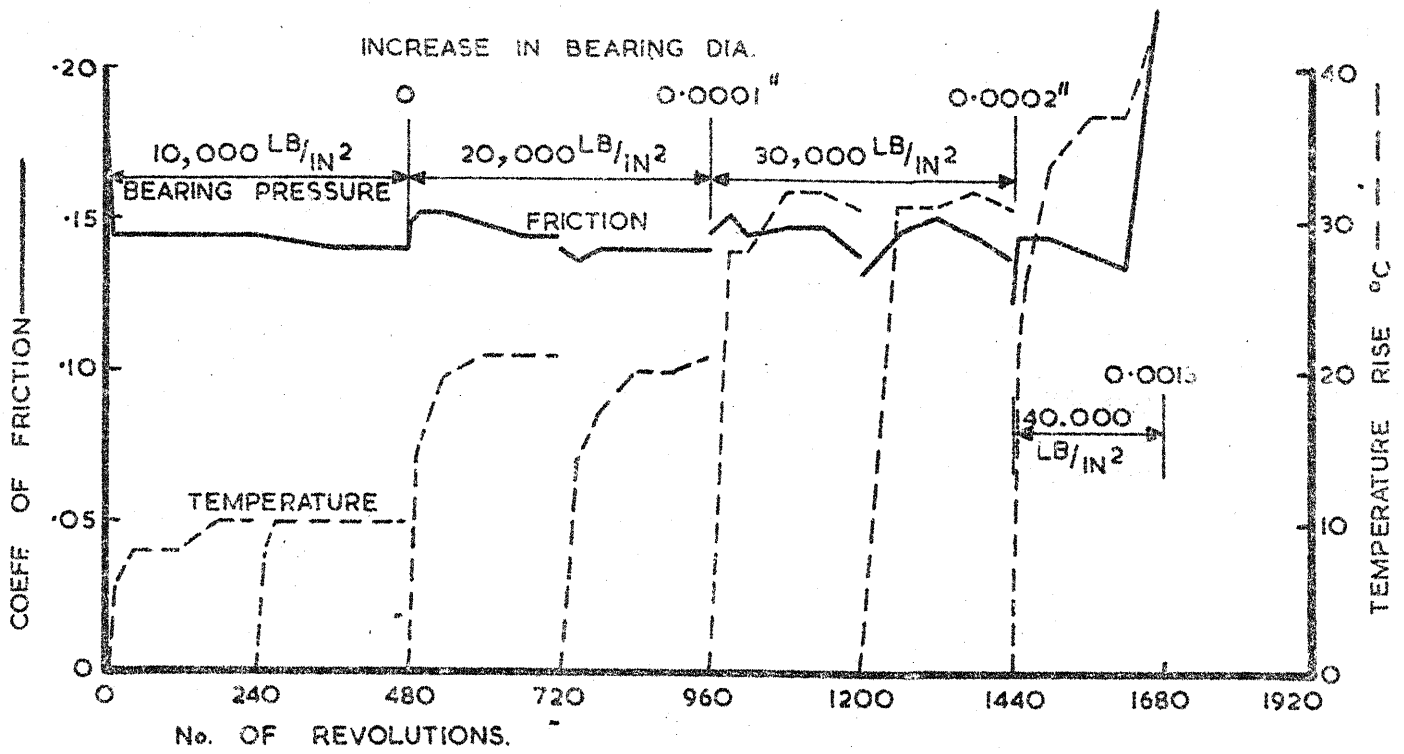

TEST 9

Bearing: No. S.S.S. Sintered Porous Stainless Steel

Surface Finish: 16 micro-inches, C.L.A. Hardness: Unreadable

Journal: No. N 2 D.T.D. 317 Nitrided

Surface Finish: 7 micro-inches, C.L.A. Hardness: 760 V.P.N.

Initial Clearance: 0.0004in. Lubrication: XG 345 every 240 cycles

Notes on Appearance of Rubbing Surfaces

After 480 cycles: Darkening of journal over width of bearing. Bearing surface almost unmarked. Sintered bush compressed over pressure area without appreciable increase in width.

TEST 10

Bearing: No. C D 1 Cadmium-plated Steel

Surface Finish: as supplied

Journal: No. P 4 S.90 Chromium-plated

Surface Finish: 7 micro-inches, C.L.A. Hardness: 480 V.P.N.

Initial Clearance: 0.0020in. Lubrication: XG 345 every 240 cycles

Notes on Appearance of Rubbing Surfaces.

After 480 cycles: Plating removed from steel over $\frac{1}{2}$ width and $\frac{1}{3}$ circumference. Bared steel area blackened. Corresponding area of chromium plating darkened.

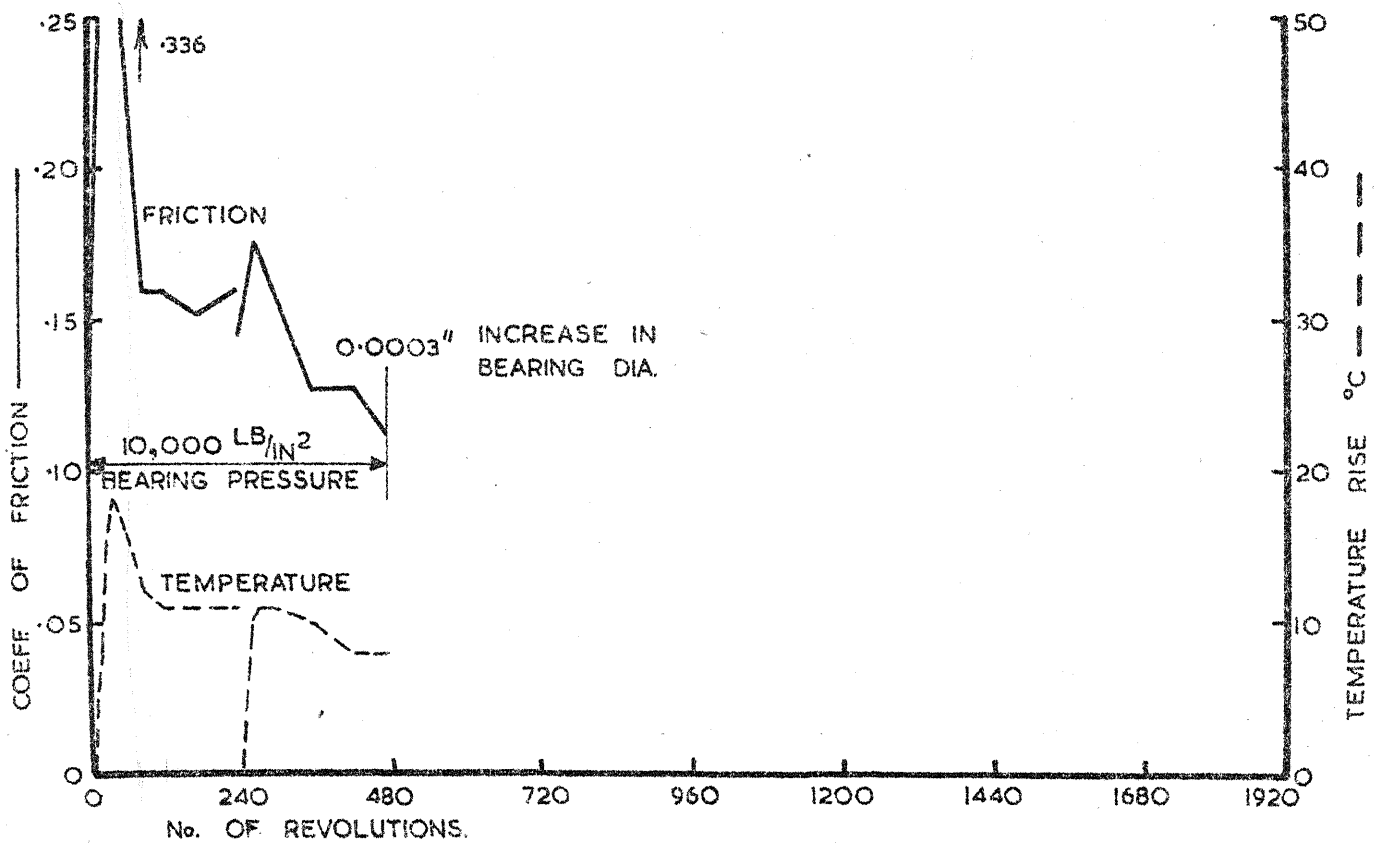
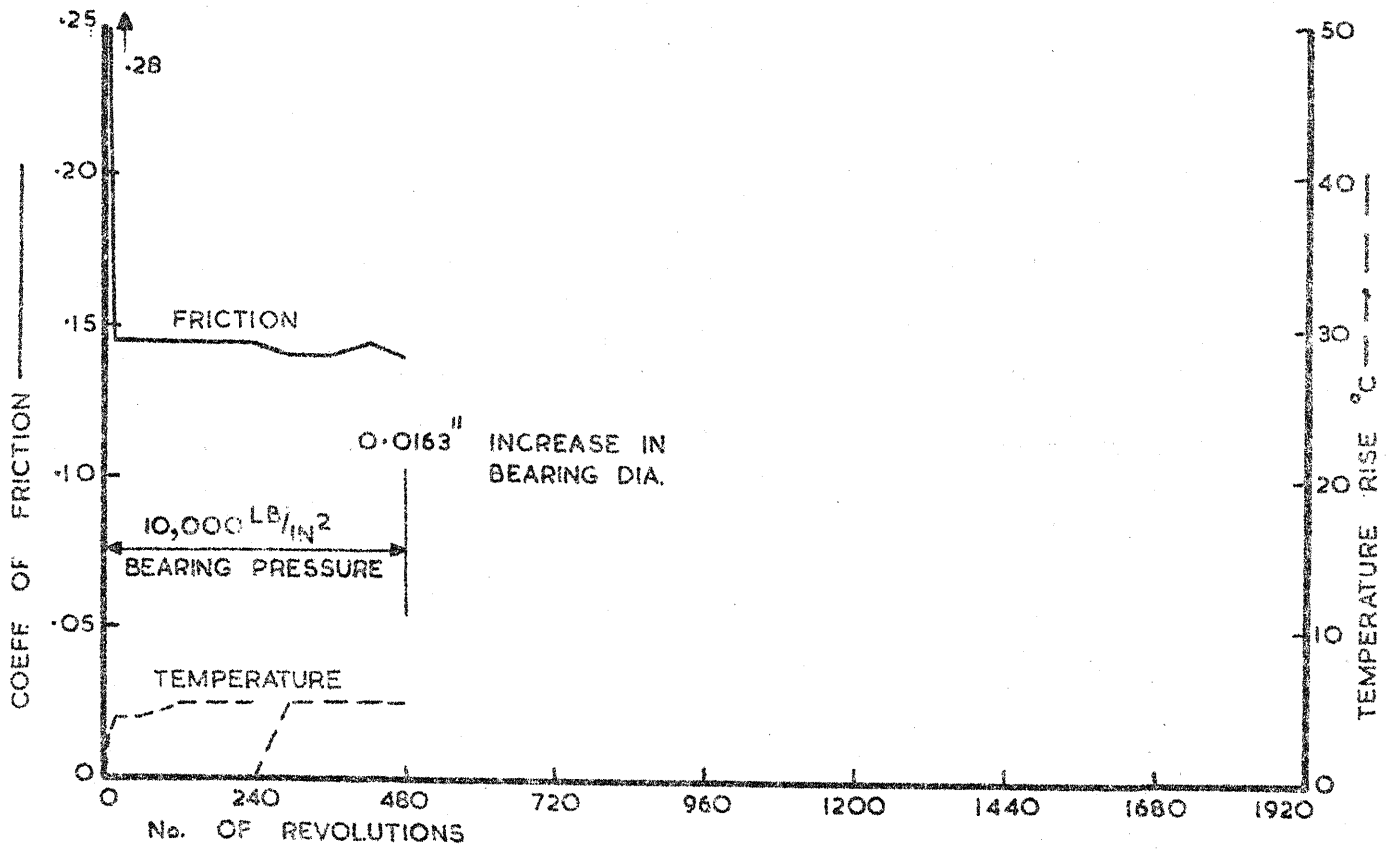

TEST 11

Bearing: No. B 1 High Duty Sintered Bronze
Surface Finish: 19 micro-inches, C.L.A. Hardness: 57 V.P.N.

Journal: No. C 1 S.82 Case-hardened
Surface Finish: 6 micro-inches, C.L.A. Hardness: 820 V.P.N.

Initial Clearance: 0.0009in. Lubrication: XG 345 every 480 cycles.

NOTE This test was carried out with greasing every 2 hours only. The results can therefore not be used for comparison with other materials when assessing relative merits. The results when compared with those of 5.2.7. do indicate the effects of lubrication.

Notes on Appearance of Rubbing Surfaces

After 480 cycles: Slight pick-up of bronze on journal.
Bearing polished over $\frac{1}{3}$ circumference.

After 960 cycles: Journal appearance as before.
Sintered bronze bush belled out to width of 0.517in. at pressure line.

TEST 12

Bearing: No. B 2 High Duty Sintered Bronze
Surface Finish: 26 micro-inches, C.L.A. Hardness: 57 V.P.N.

Journal: No. C 3 S.82 Case-hardened
Surface Finish: 6 micro-inches, C.L.A. Hardness: 820 V.P.N.

Initial Clearance: 0.0010in. Lubrication: XG 345 every 240 cycles.

Notes on Appearance of Rubbing Surfaces

After 480 cycles: Fine pick-up of bronze on journal.
Bearing polished over $\frac{1}{3}$ circumference.

After 960 cycles: Fine smooth pick-up of bronze on journal, of slightly greater intensity than before. Bearing polished and rubbed over $\frac{1}{2}$ circumference. Belling of sintered bronze bush to a width of 0.517in. at pressure line.

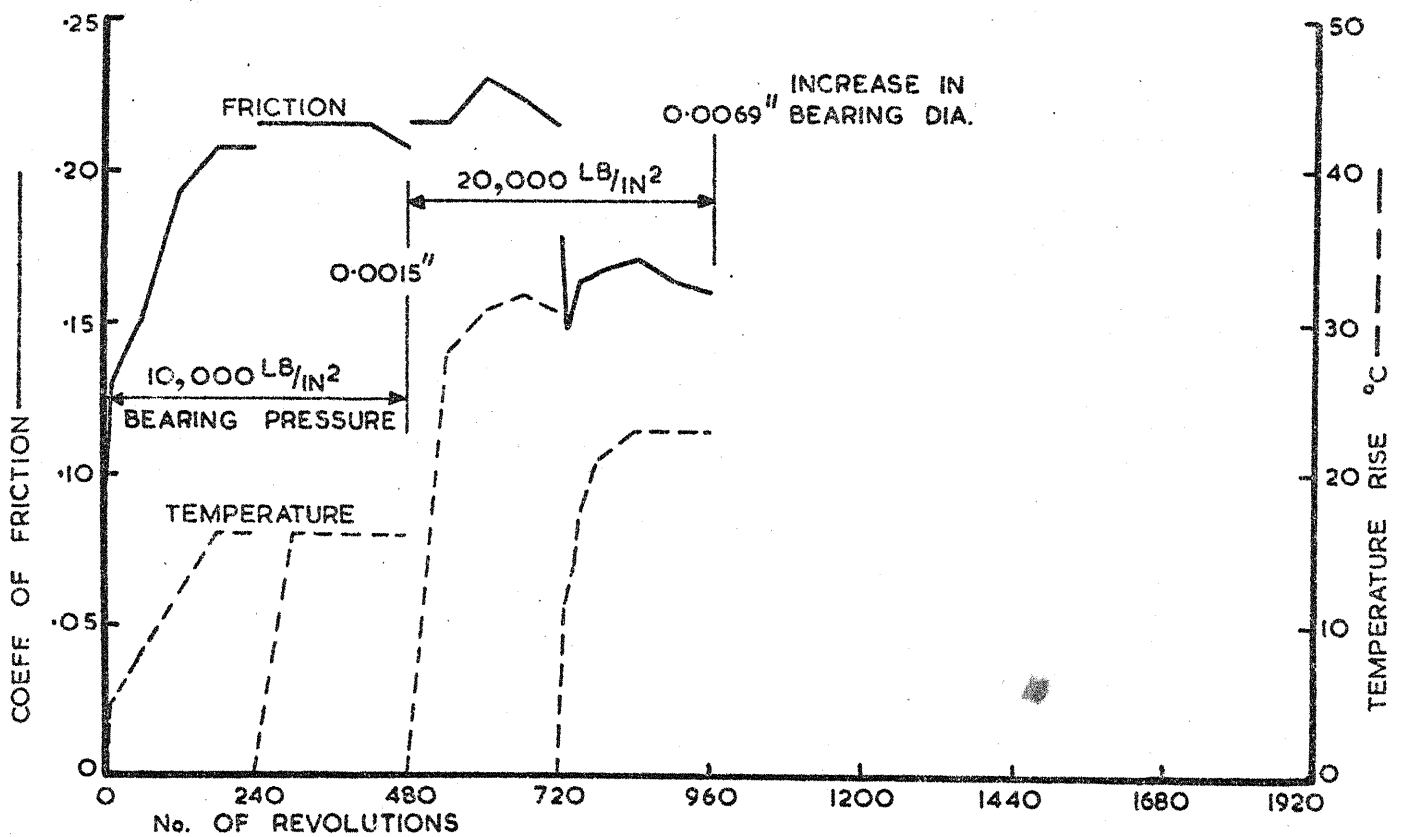
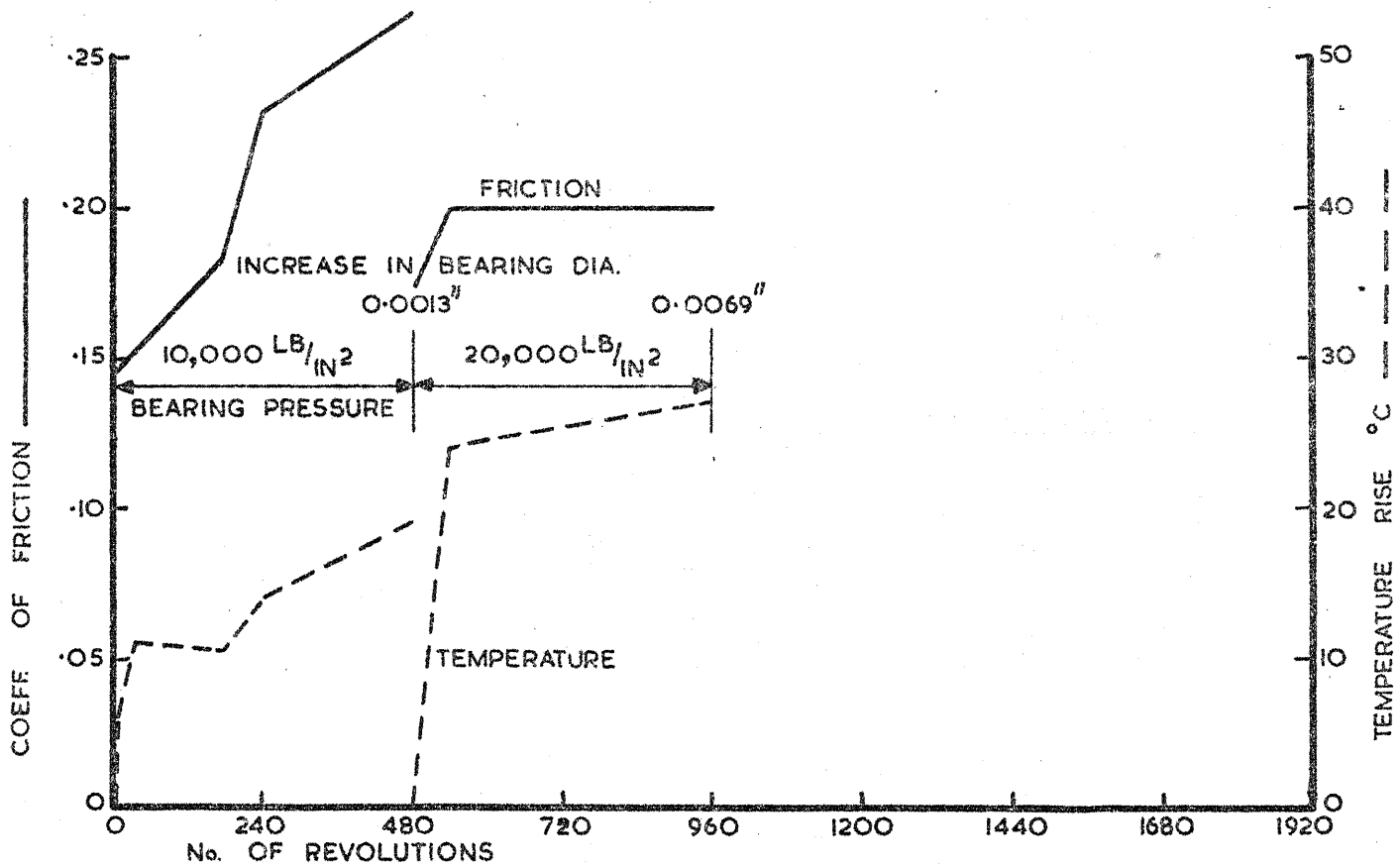

TEST 13

Bearing: No. I 2 18 Ton Sintered Alloy Iron
Surface Finish: 19 micro-inches, C.L.A. Hardness: 80 V.P.N.
Journal: No. P 2 S.90 Chromium-plated
Surface Finish: 6 micro-inches, C.L.A. Hardness: 470 V.P.N.
Initial Clearance: 0.0006in. Lubrication: XG 345 every 240 cycles.

Notes on Appearance of Rubbing Surfaces

After 480 cycles: Bearing scored lightly over 1/3 circumference and 2/3 width. Journal slightly darkened.

After 960 cycles: Bearing bore darkened to same intensity as journal which appeared as before. Slight burr on edge of bush.

After 1200 cycles: Sintered iron pushed out to ragged edges. Severe scoring of the bearing. Journal darkened over width of bearing. Chromium plating unaffected apart from darkening.

TEST 14

Bearing: No. C D 2 Cadmium-plated Steel
Surface Finish: as supplied Hardness: -
Journal: No. C 9 S.82 Case-hardened
Surface Finish: 8 micro-inches, C.L.A. Hardness: 820 V.P.N.
Initial Clearance: 0.0024in. Lubrication: XG 345 every 240 cycles

Notes on Appearance of Rubbing Surfaces

After 240 cycles: Part of cadmium-plating torn away. Bared steel scored and darkened. Cadmium smeared on journal.

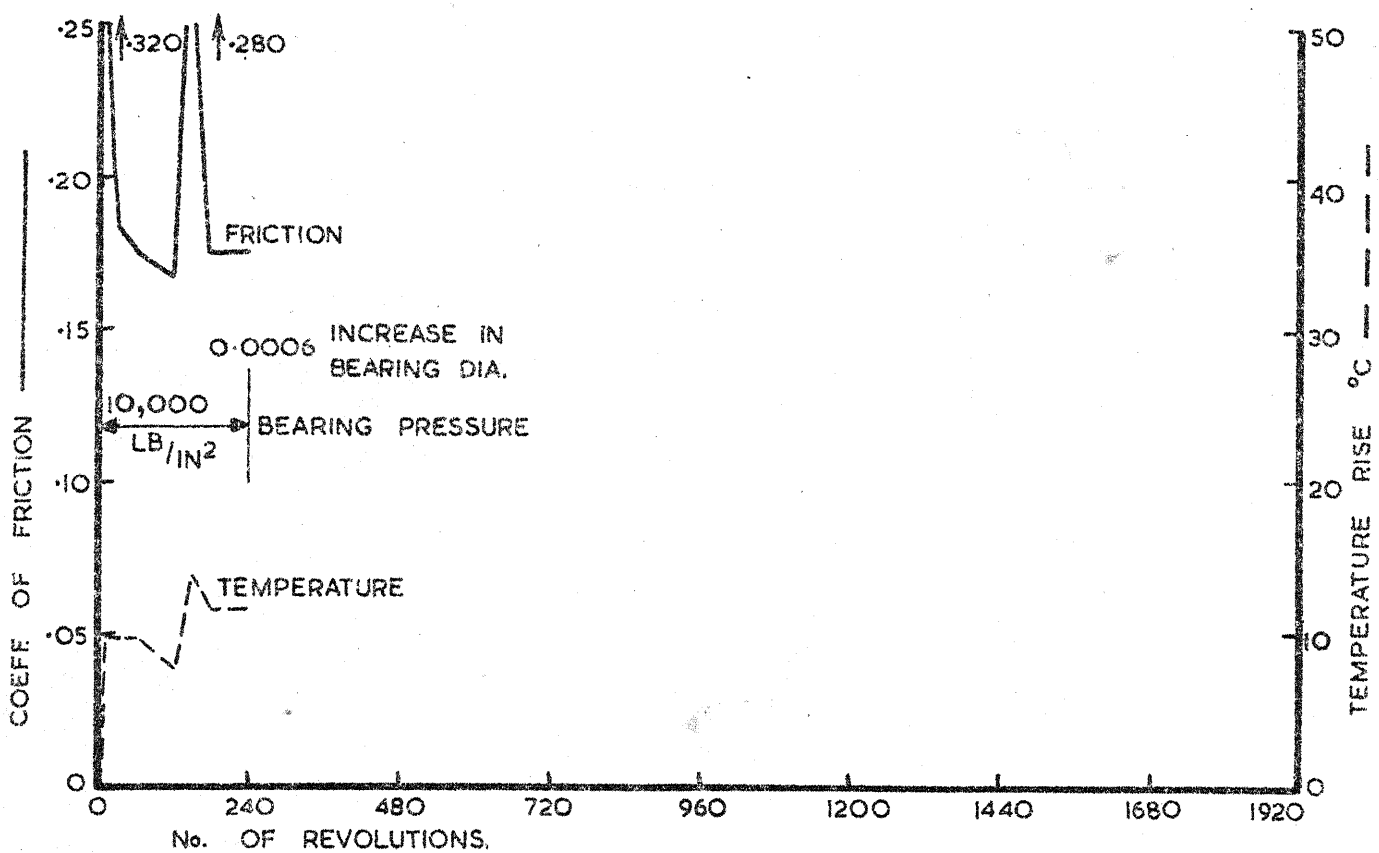
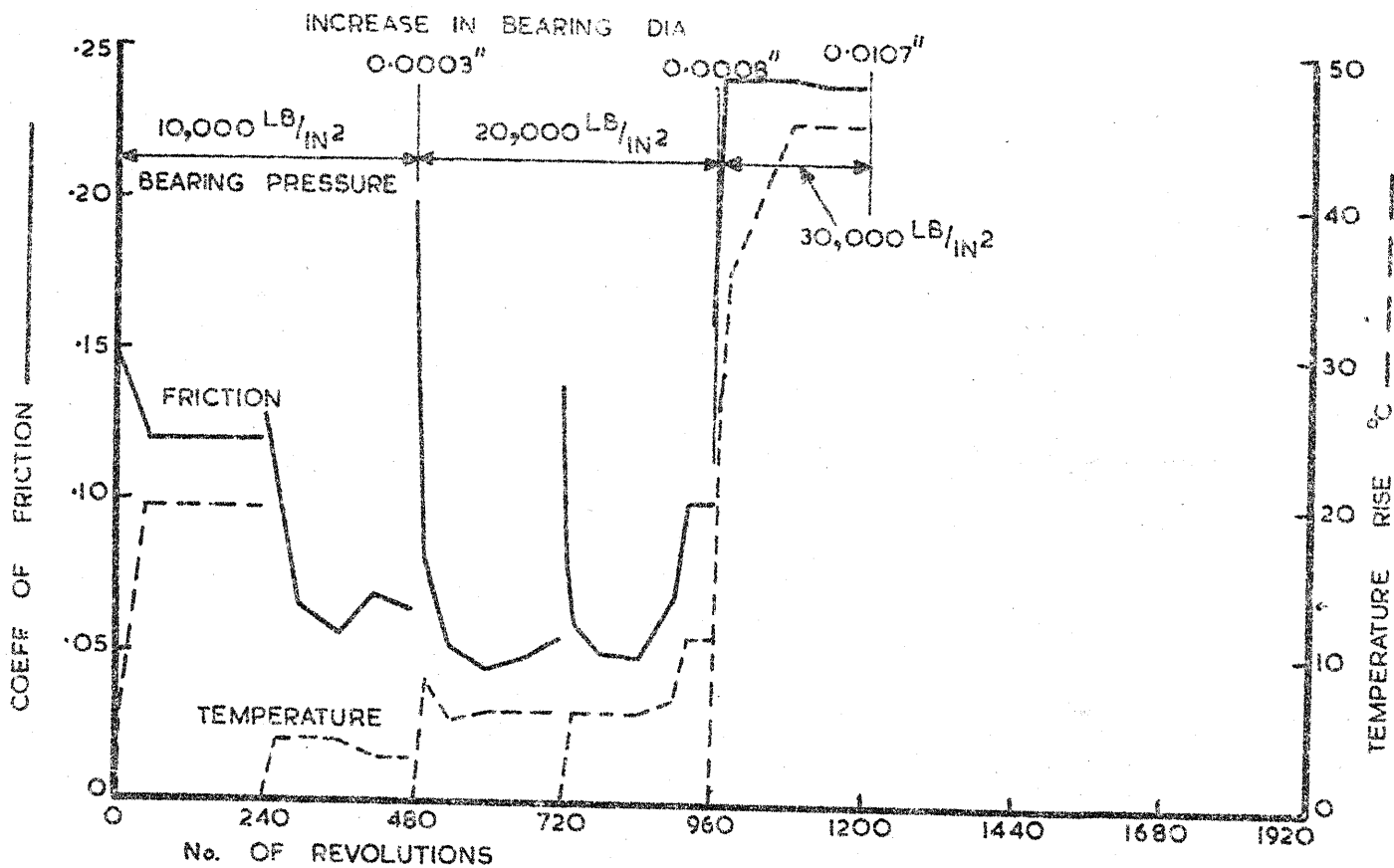

TEST 15

Bearing: No. S W 2 Glacier Standard Wrapped
Surface Finish: 50 micro-inches, C.L.A. Hardness: 25 V.P.N.

Journal: No. C 8 S.82 Case-hardened
Surface Finish: 7 micro-inches, C.L.A. Hardness: 820 V.P.N.

Initial Clearance: 0.0015in. Lubrication: XG 345 every 240 cycles

Notes on Appearance of Rubbing Surfaces

After 480 cycles: Very light polishing marks on journal. Some small particles of copper dispersed in grease. Bearing pitted and scored to moderate extent over $\frac{1}{2}$ bearing area.

After 960 cycles: More copper dispersed in grease. Light smearing of copper on journal. Bearing pitting and scoring rather heavier than before.

TEST 16

Bearing: No. S W 4 Glacier Standard Wrapped
Surface Finish: 50 micro-inches, C.L.A. Hardness: 25 V.P.N.

Journal: No. C 6 S.82 Case-hardened
Surface Finish: 9 micro-inches, C.L.A. Hardness: 820 V.P.N.

Initial Clearance: 0.0012in. Lubrication: D.T.D. 577 every 480 cycles

Notes on Appearance of Rubbing Surfaces

After 480 cycles: Several smears of copper on journal. Bearing scored and darkened over $\frac{1}{3}$ circumference. Copper particles in grease.

After 960 cycles: Bearing scored and pitted over $\frac{1}{2}$ circumference, to greater extent than in Test 15. Smears of copper of slightly greater intensity than before on journal. Copper particles in grease.

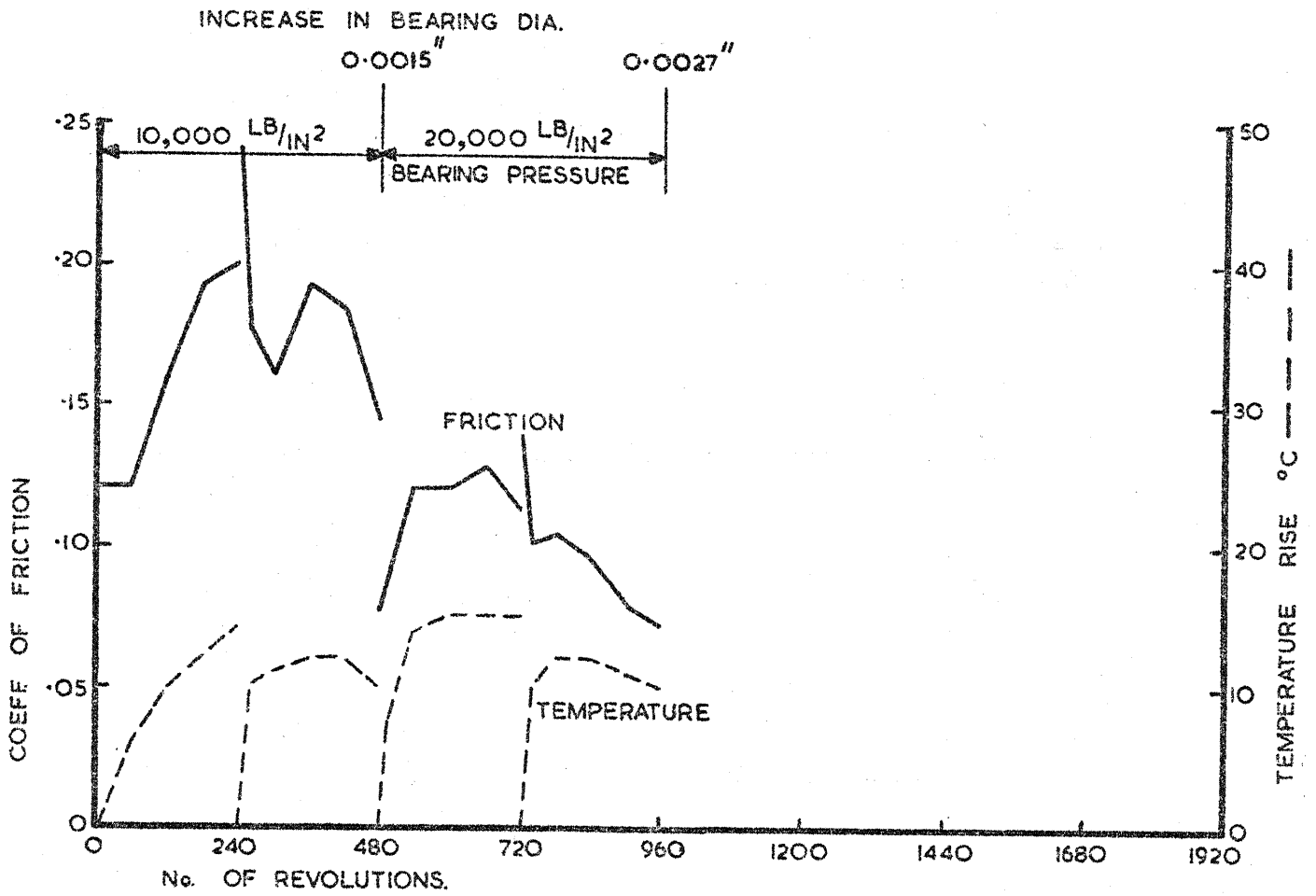
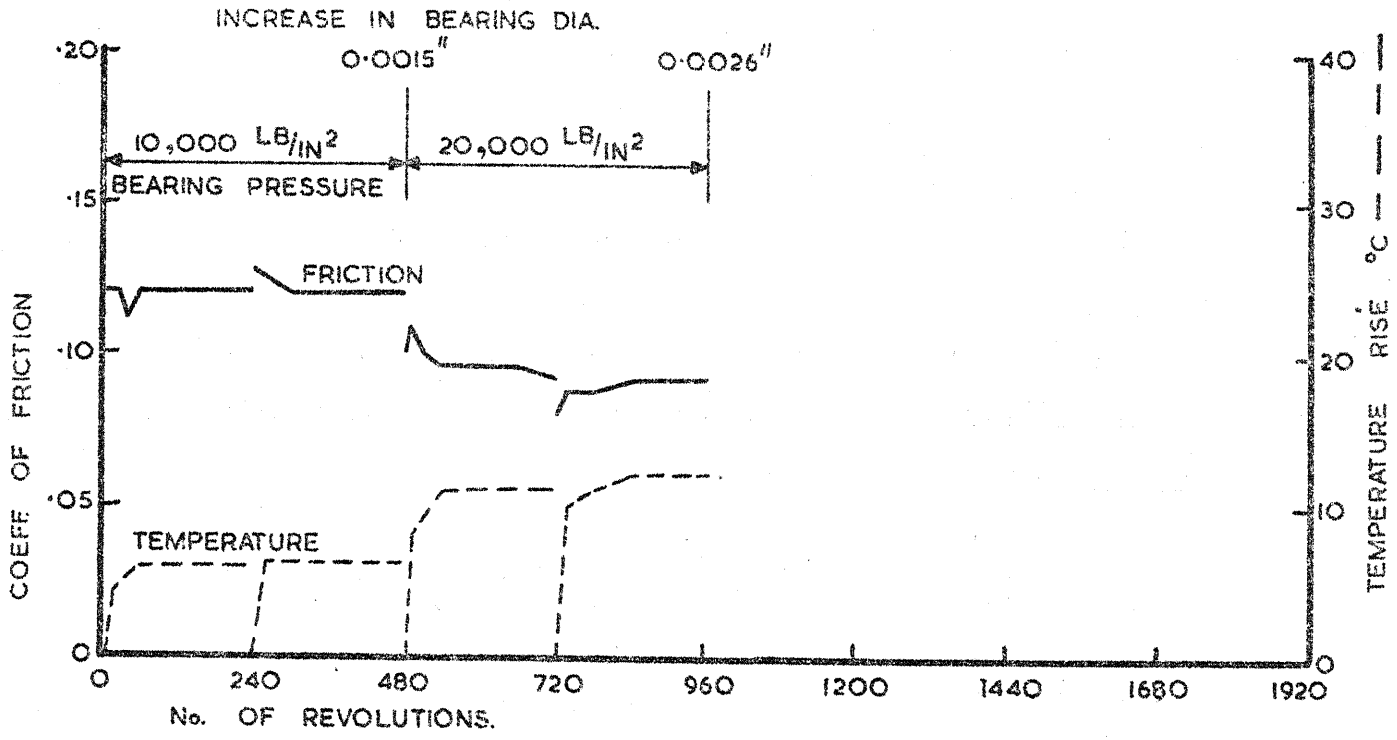

TEST 17

Bearing: No. S W 1 Glacier Standard Wrapped
Surface Finish: 70 micro-inches, C.L.A. Hardness: 25 V.P.N.
Journal: No. C 7 S.82 Case-hardened
Surface Finish: 10 micro-inches, C.L.A. Hardness: 820 V.P.N.
Initial Clearance: 0.0017in. Lubrication: XG 345 every 480 cycles

Notes on Appearance of Rubbing Surfaces

After 480 cycles: Very light trace of copper on journal. Some copper particles in grease. Bearing colour unchanged but surface scored and pitted.

After 960 cycles: More copper in grease. Shaft almost unmarked: loose deposit of copper was easily rubbed off. Some pitting and scoring but not as marked as in Test 16.

TEST 18

Bearing: No. T E 2 Sintered Bronze and P.T.F.E.
Surface Finish: 60 micro-inches, C.L.A.
Journal: No. C 2 S.82 Case-hardened
Surface Finish: 6 micro-inches, C.L.A. Hardness: 820 V.P.N.
Initial Clearance: 0.0008in. Lubrication: No grease lubrication

Notes on Appearance of Rubbing Surfaces

After 480 cycles: Flakes of bronze between journal and bearing. Journal coloured over $\frac{2}{3}$ width of bearing with a continuous coating of bronze. Bearing polished over $\frac{2}{3}$ width and $\frac{1}{2}$ circumference.

After 960 cycles: Journal covered completely with coating of bronze over whole bearing width. Considerable number of flakes of bronze adhering loosely to journal. Bearing polished.

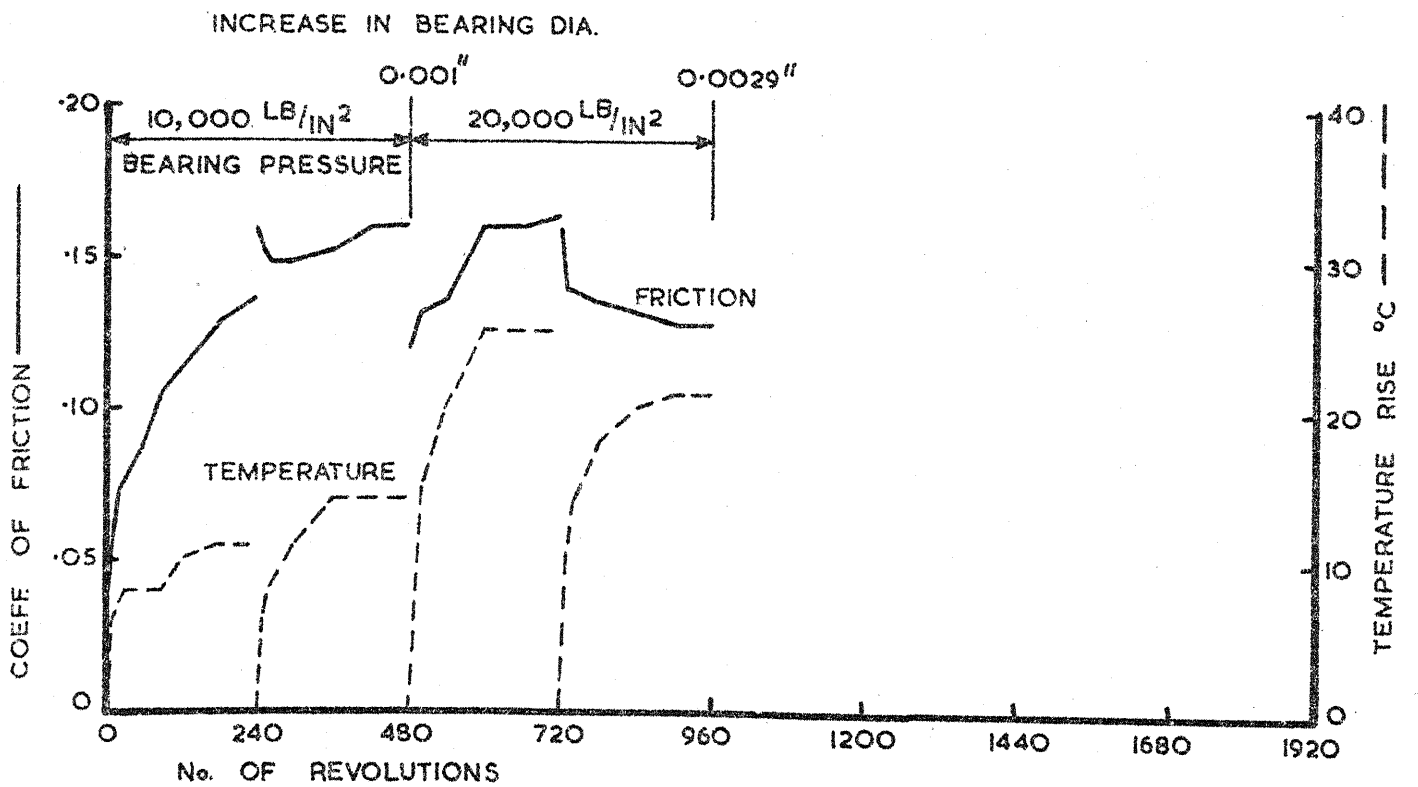
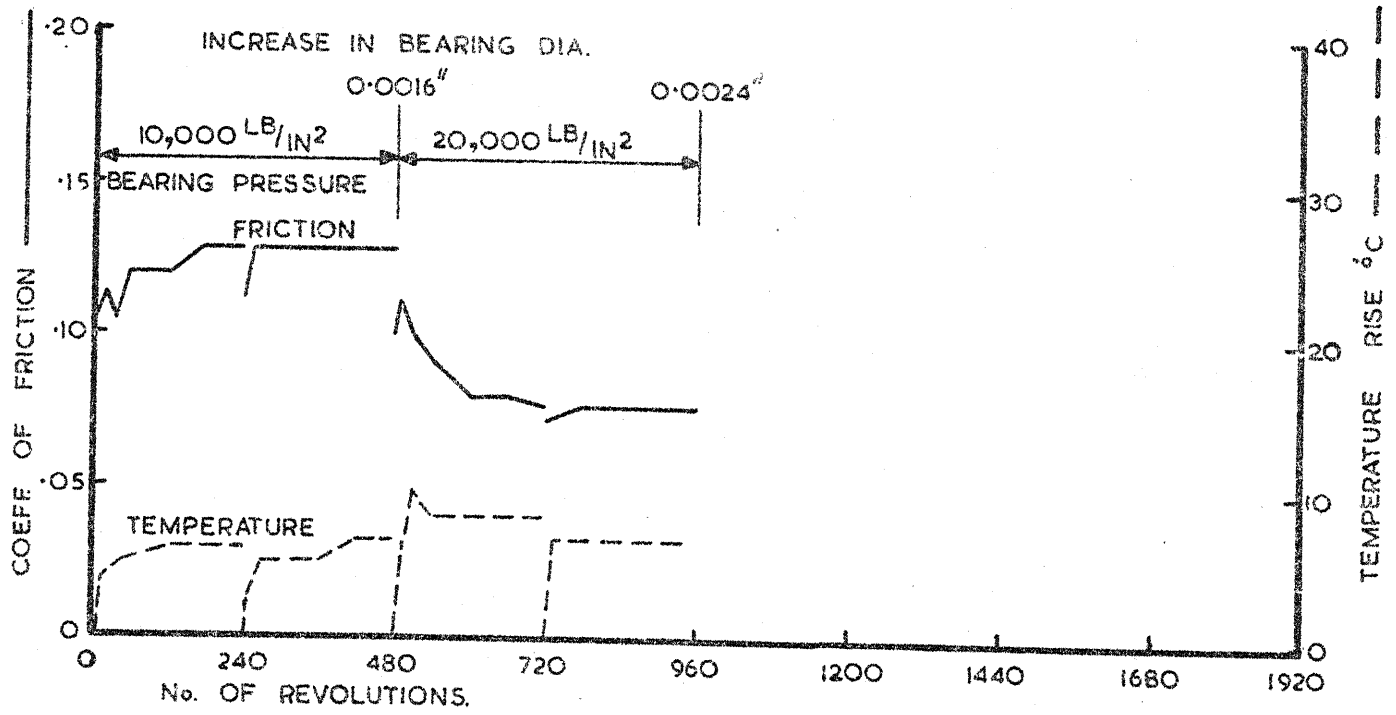

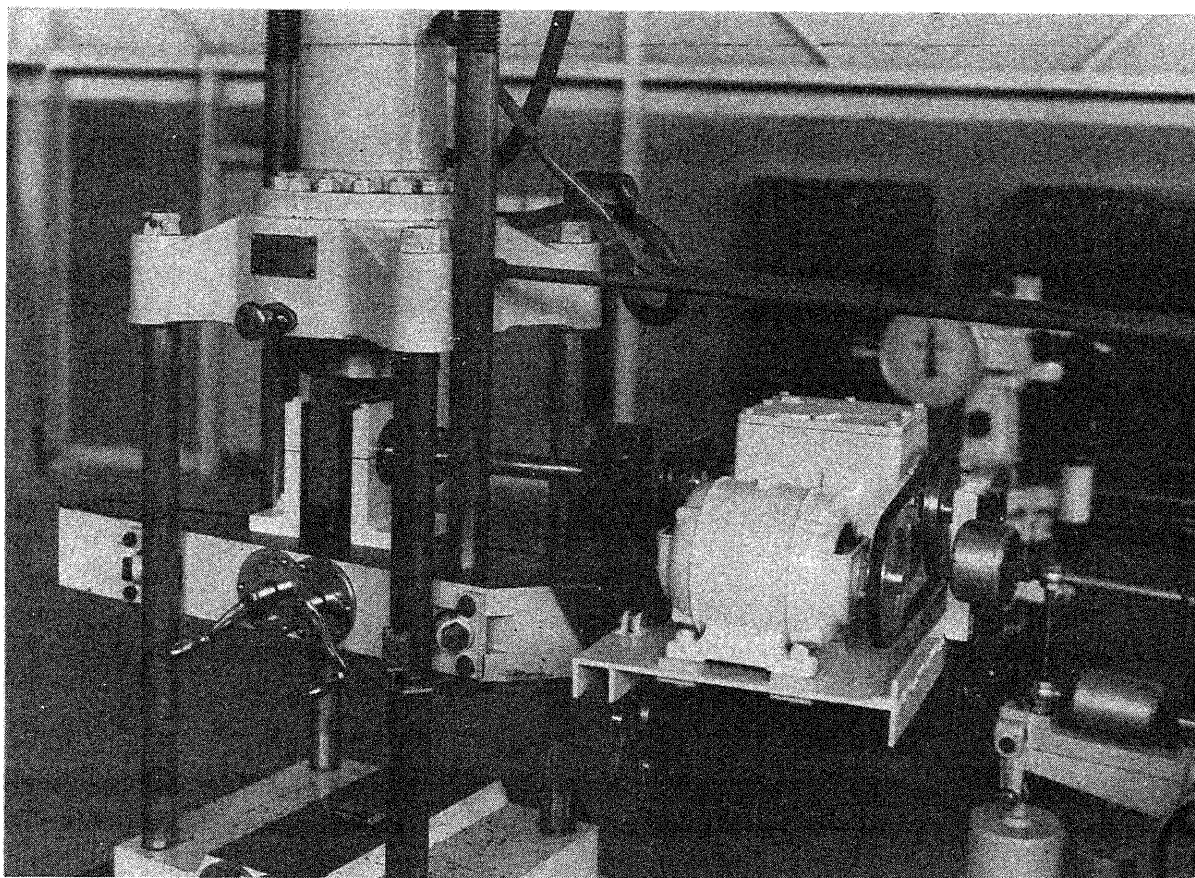

TEST RIG: FRONT VIEW OF DRIVING ASSEMBLY AND
BEARING ASSEMBLY

FIG. 2.

COLLEGE OF AERONAUTICS
NOTE No. 12.

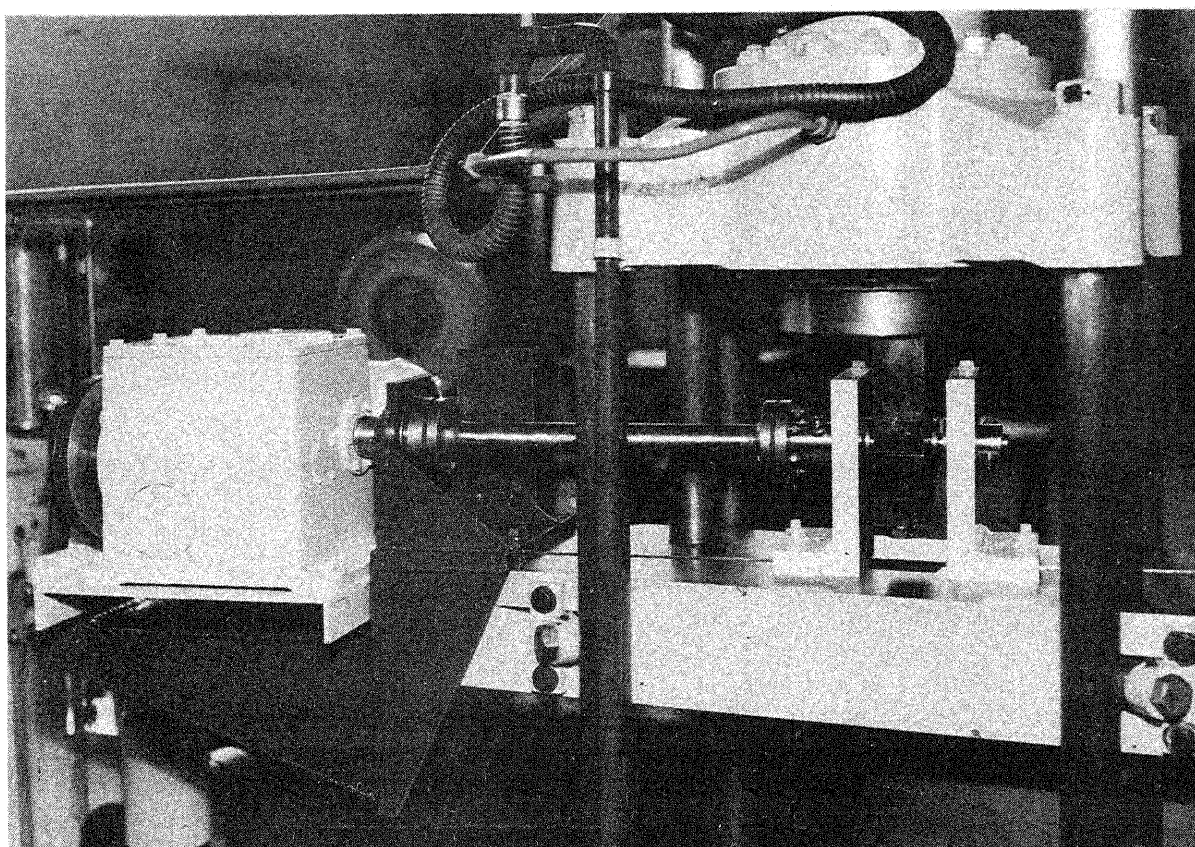

TEST RIG: REAR VIEW OF BEARING ASSEMBLY AND
DRIVING ASSEMBLY

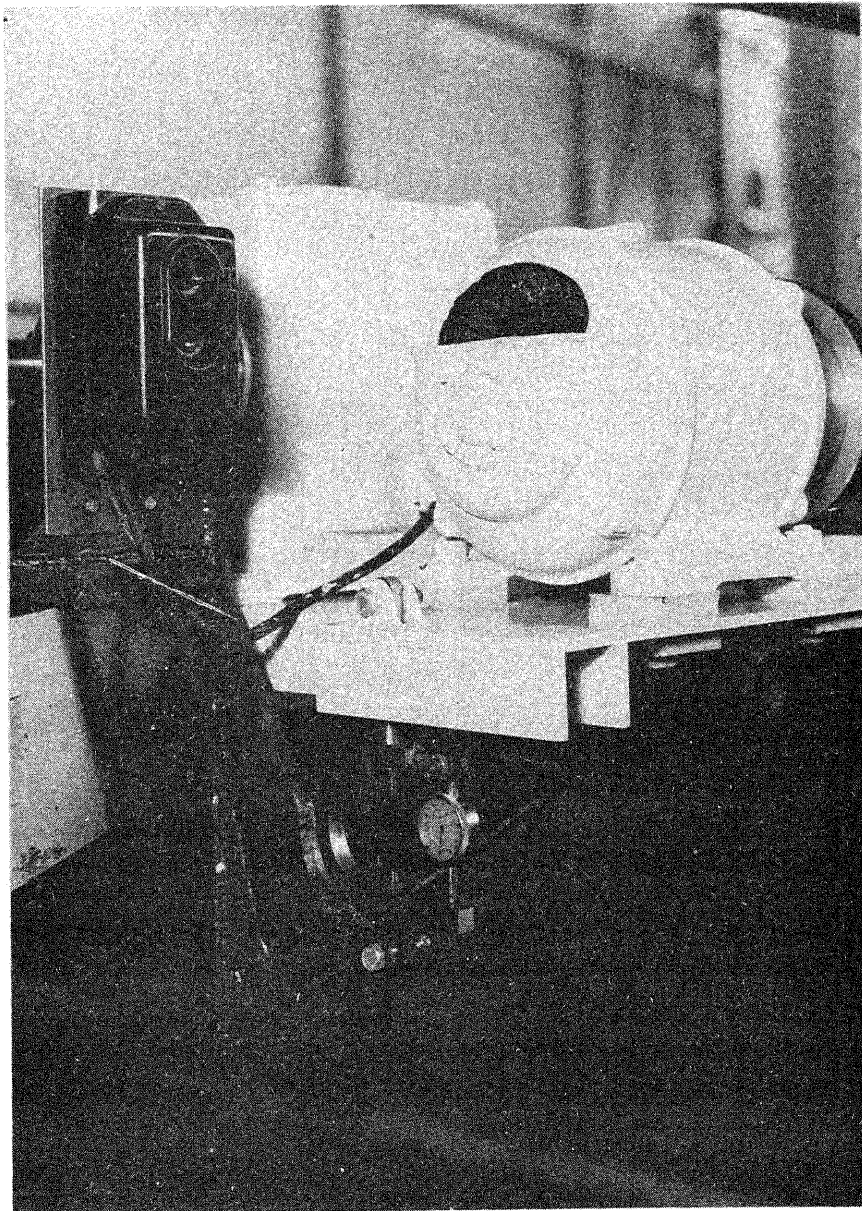

TEST RIG: CLOSE-UP OF TORQUE DYNAMOMETER

FIG. 4.

FRictional TORQUE
OF SUPPORT BEARINGS

DYNAMOMETER READING

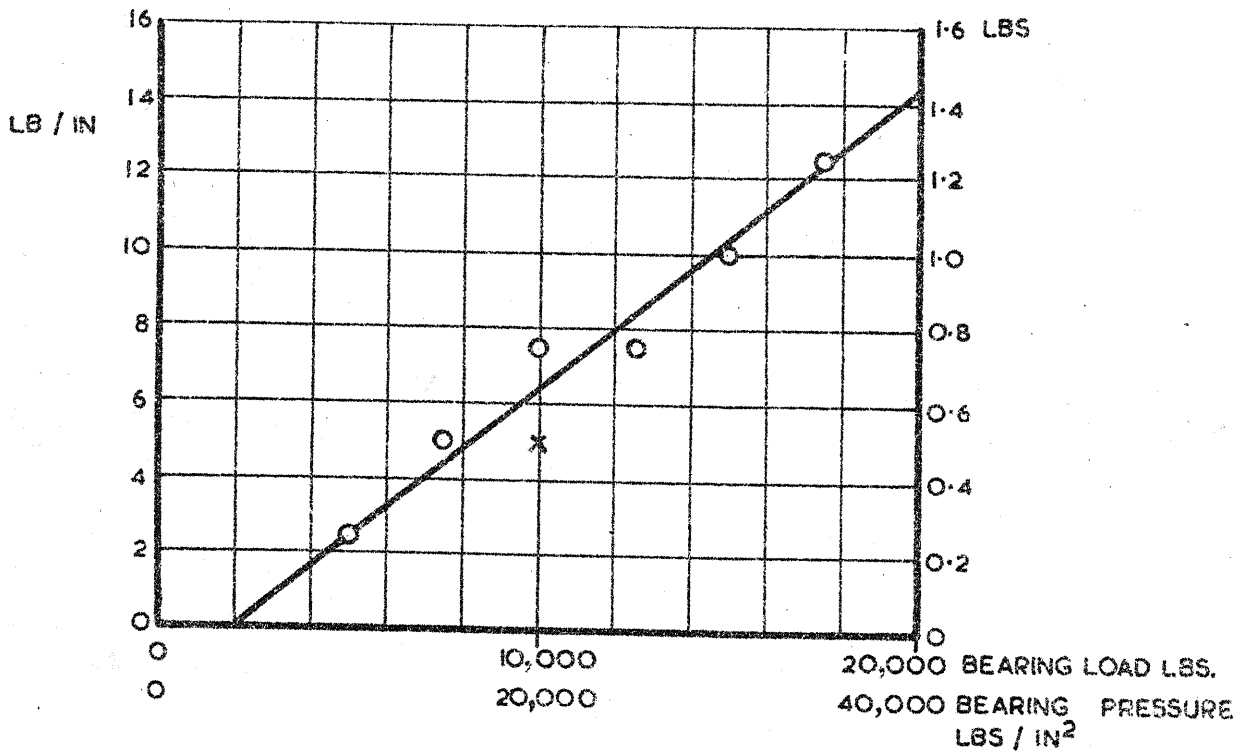

FRictional TORQUE OF SUPPORT BEARINGS

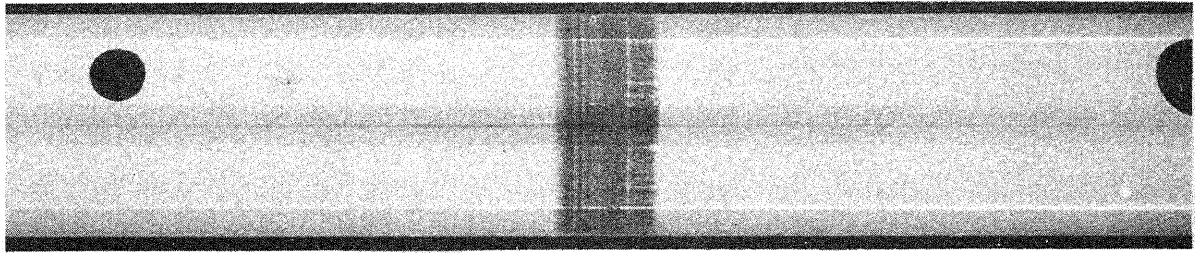

TEST No. 1. P1. S.90. CHROMIUM PLATED JOURNAL
(RUN WITH HIDURAX SPECIAL BEARING)

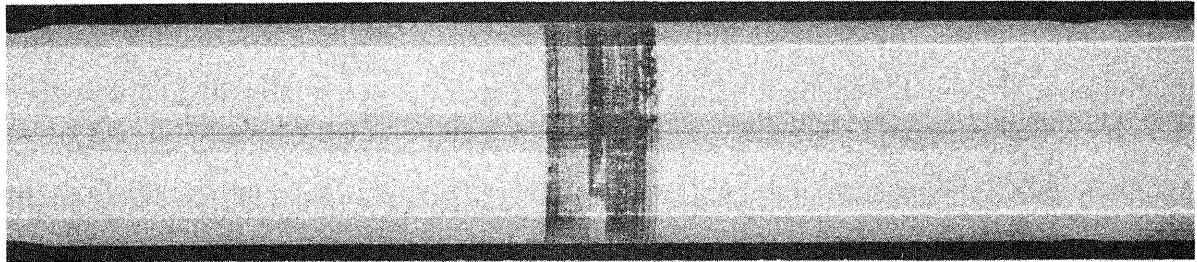

TEST No. 2. P3. S.90. CHROMIUM PLATED JOURNAL
(RUN WITH GREY CAST IRON BEARING)

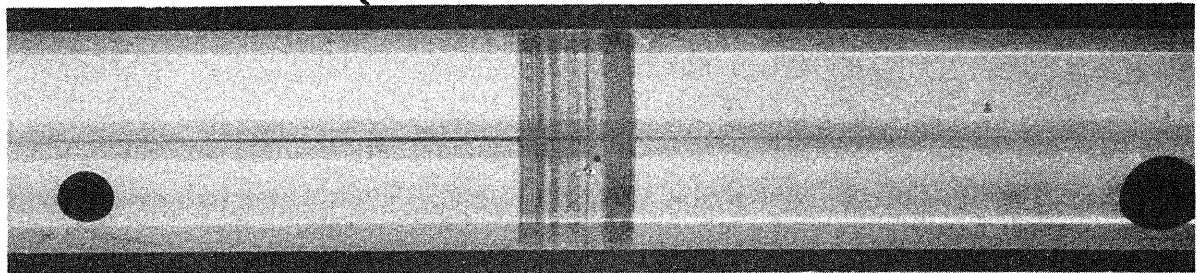

TEST No. 6. N.4. D.T.D. 317 NITRIDED JOURNAL
(RUN WITH HIDUREL 5 BEARING)

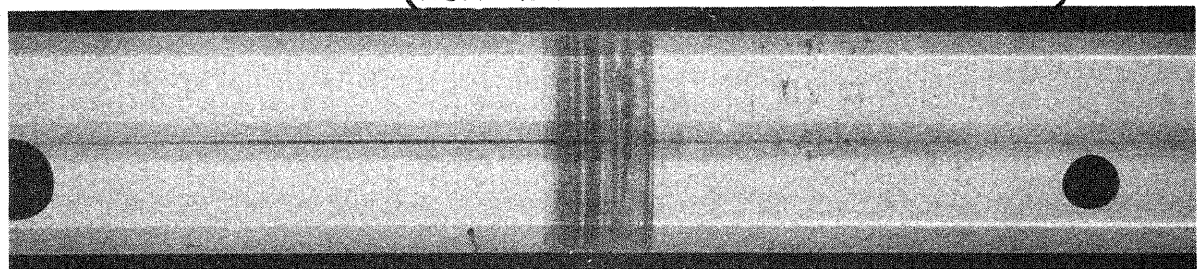

TEST No. 7. N.5. D.T.D. 317 NITRIDED JOURNAL
(RUN WITH GREY CAST IRON BEARING)

SOME JOURNALS AFTER TEST

FIG. 6 .

COLLEGE OF AERONAUTICS
NOTE No. 12.

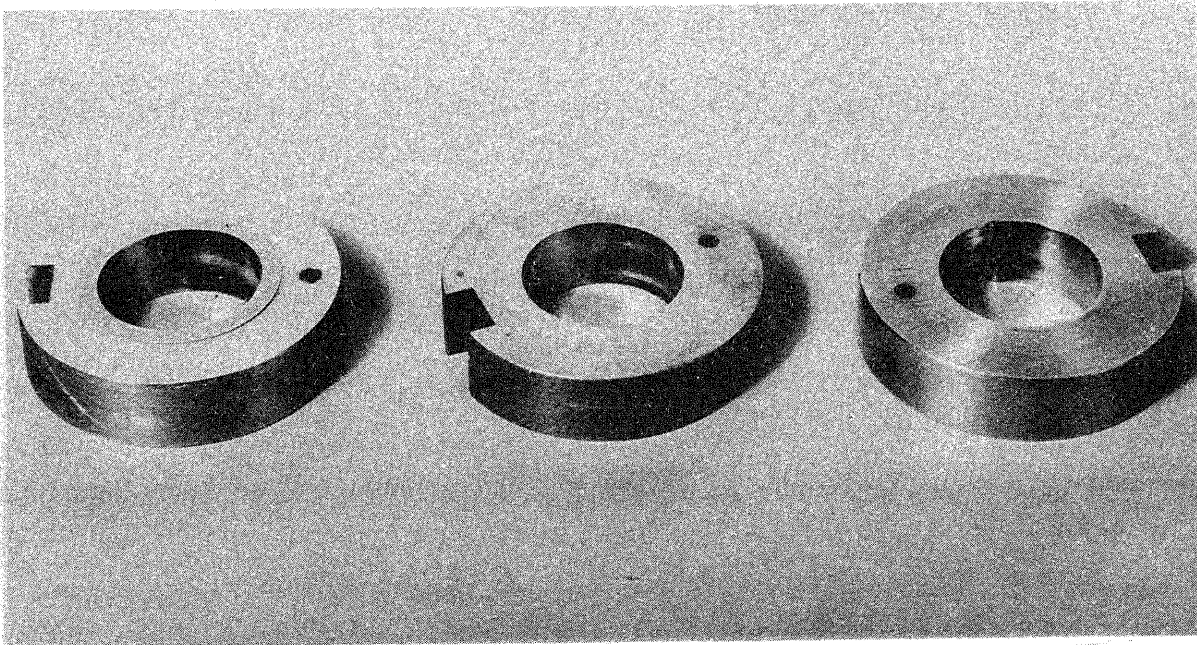

B.I. SINTERED BRONZE.
(S. 82. CASE-HARDENED.)

C.I.I. GREY CAST IRON.
(S. 90. CHROMIUM-PLATED.)

H.S. 4. HIDURAX SPECIAL.
(D.T.D. 317 NITRIDED.)

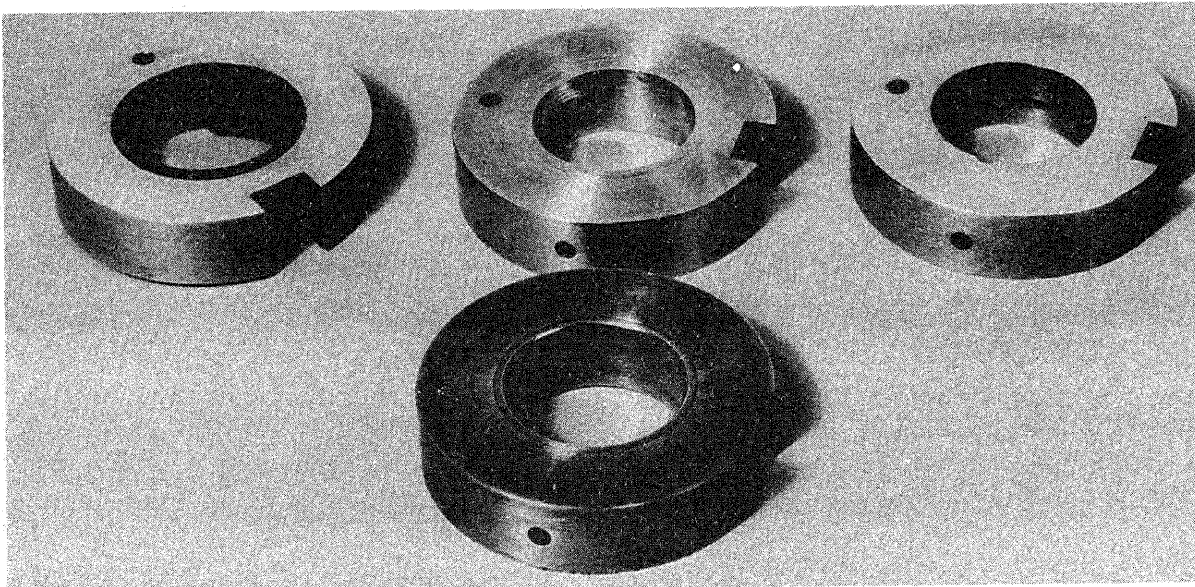

L.F. FEROBESTOS 'L.F.'
(D.T.D. 317 NITRIDED.)

H.S. 3. HIDURAX SPECIAL.
(S. 90. CHROMIUM-PLATED.)

C.I.I. GREY CAST IRON.
(D.T.D. 317 NITRIDED.)

NOTE:— THE MATERIAL OF THE JOURNAL WITH WHICH EACH BEARING
WAS RUN IS GIVEN IN THE BRACKETS.

SOME BEARINGS AFTER TEST

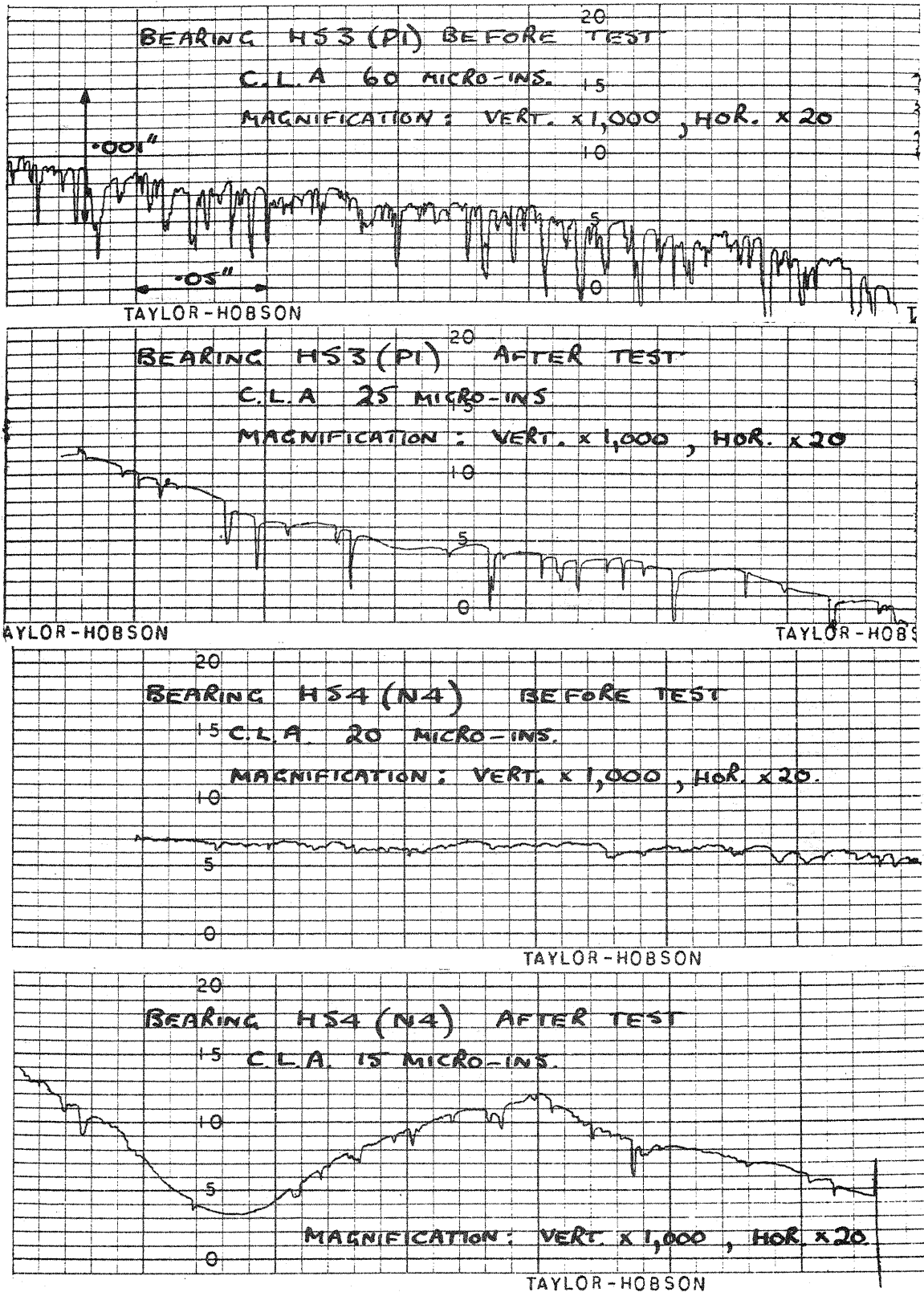

TALYSURF SURFACE ROUGHNESS RECORDS OF THE MIDURAX SPECIAL BEARINGS BEFORE AND AFTER TEST.

FIG. 8.

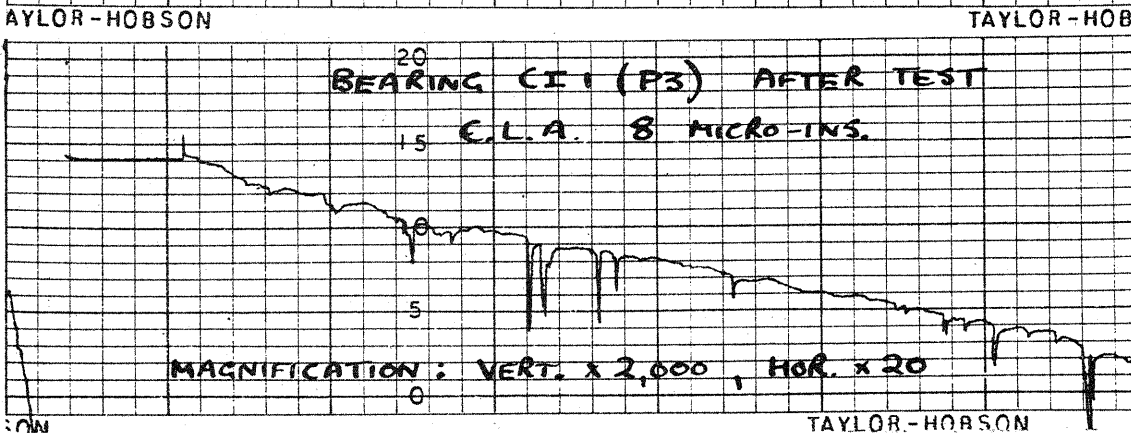
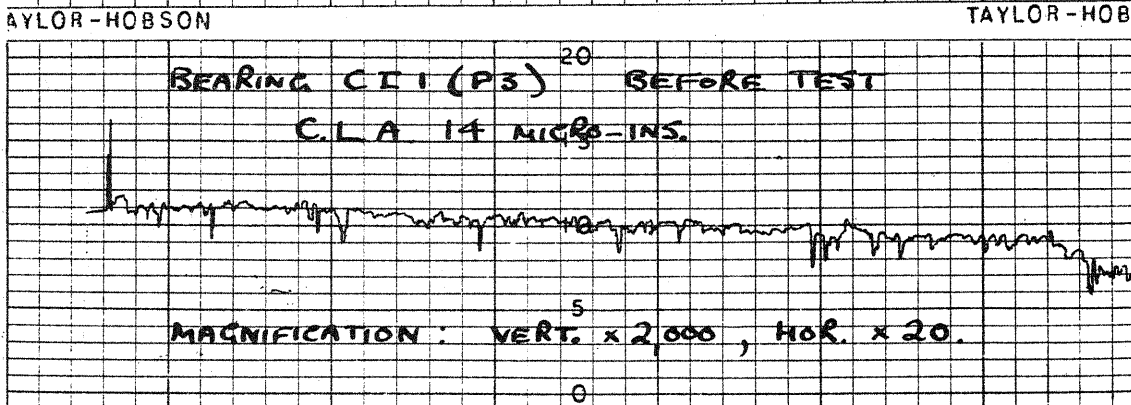
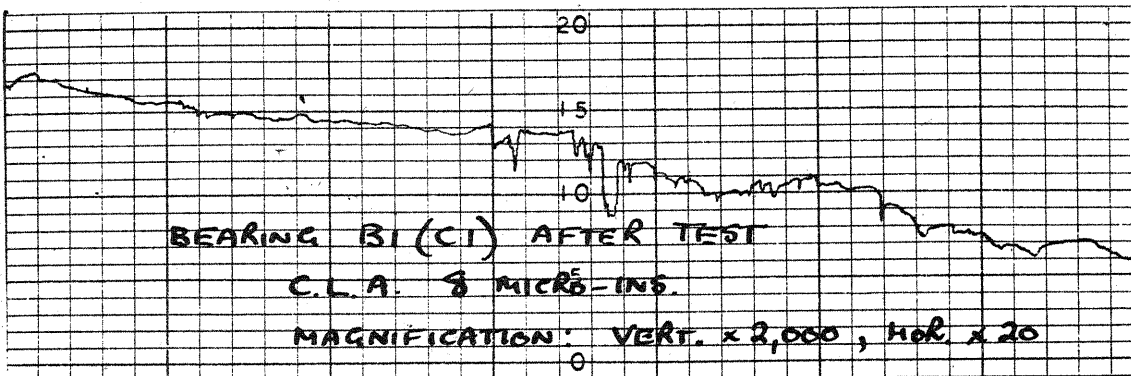
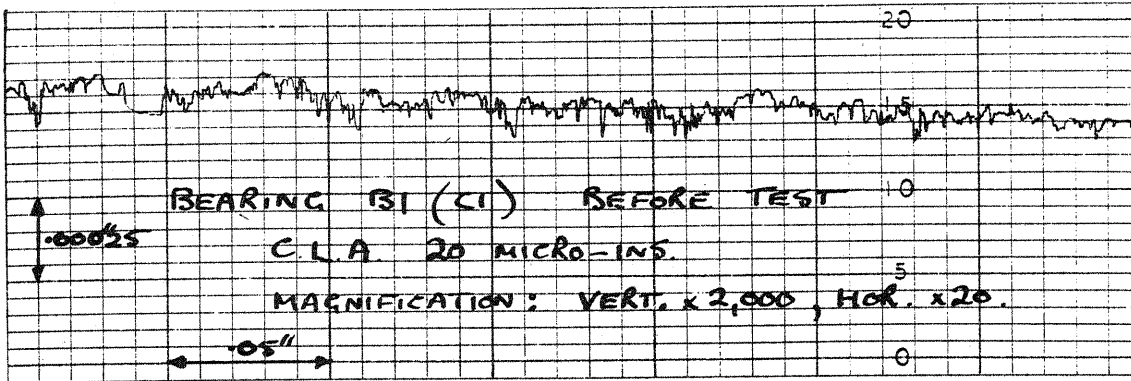

TALYSURF SURFACE ROUGHNESS RECORDS OF A SINTERED BRONZE AND A CAST IRON BEARING BEFORE AND AFTER TEST.

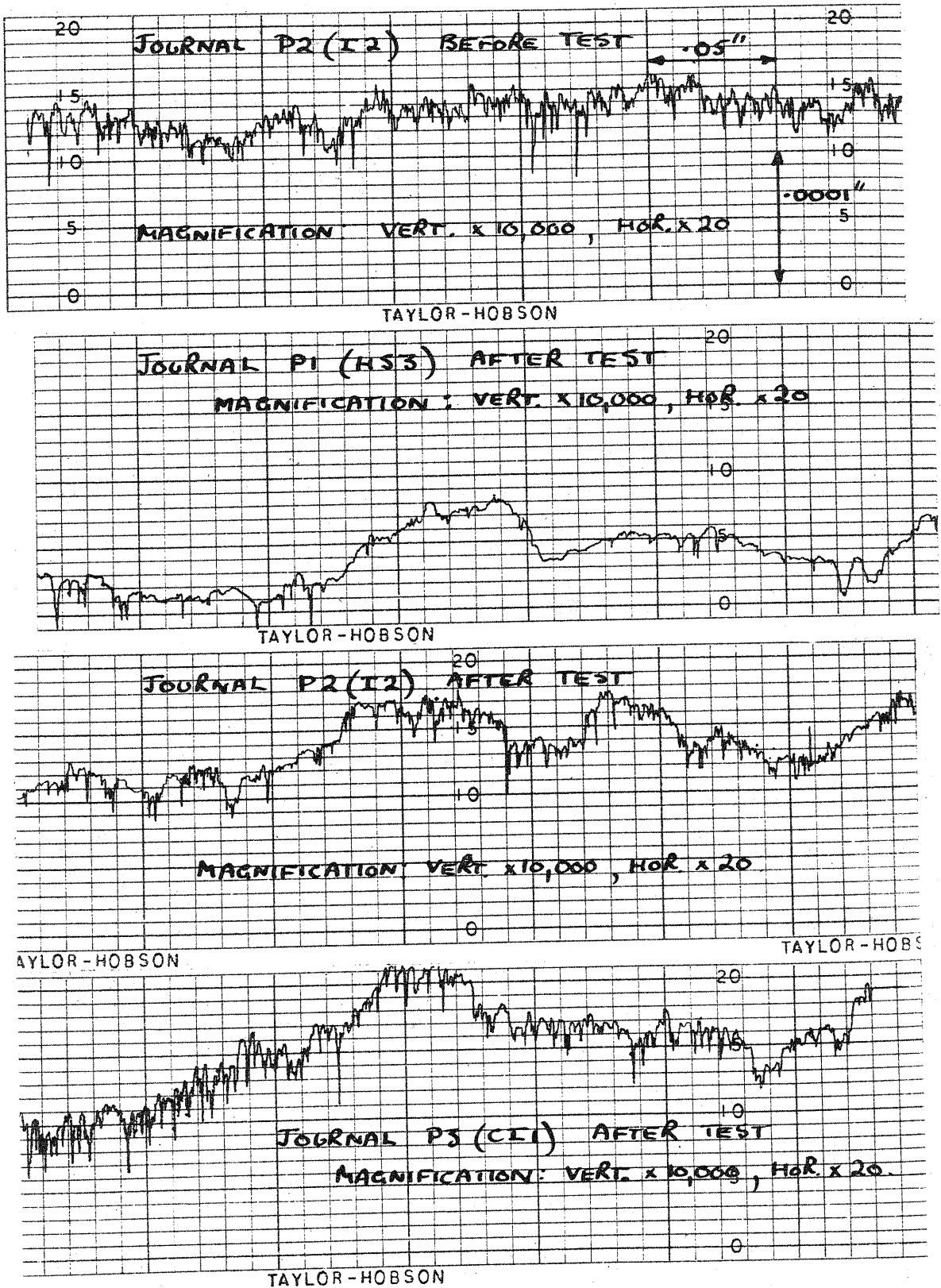

TALYSURF SURFACE ROUGHNESS RECORDS OF SOME OF THE CHROMIUM PLATED JOURNALS BEFORE AND AFTER TEST.

FIG. 10.

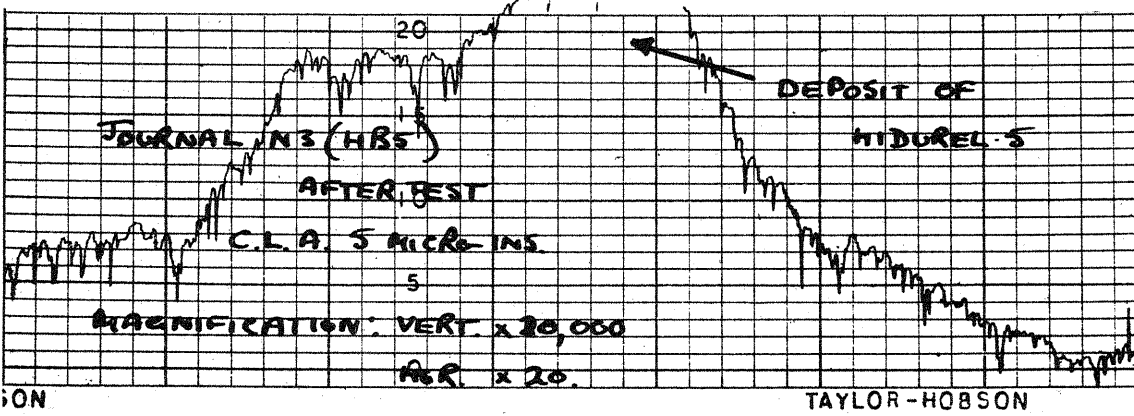
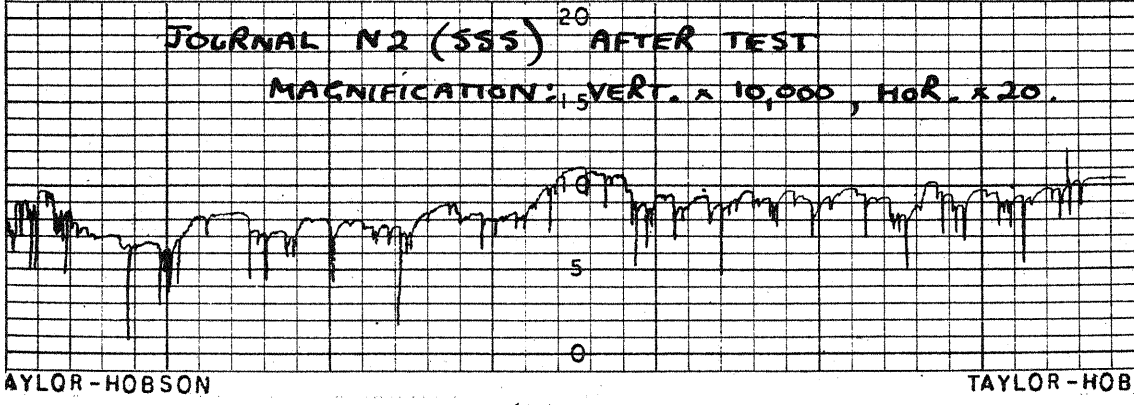
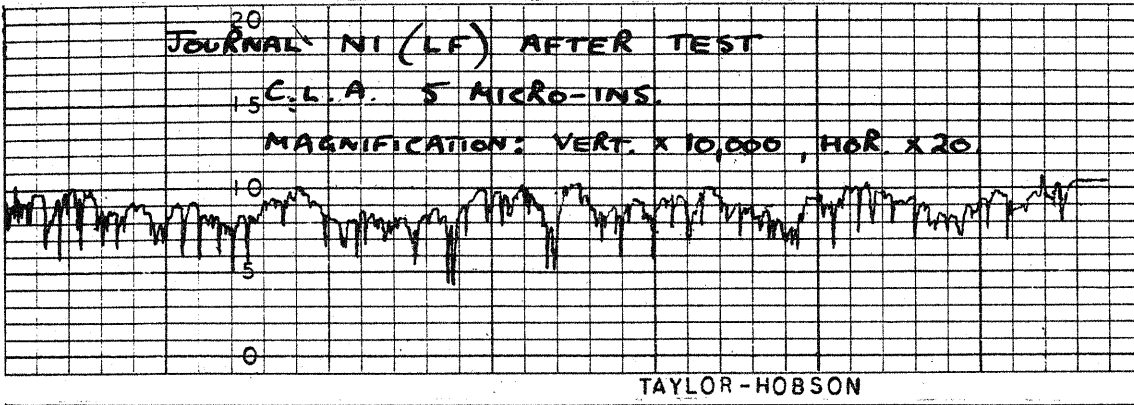
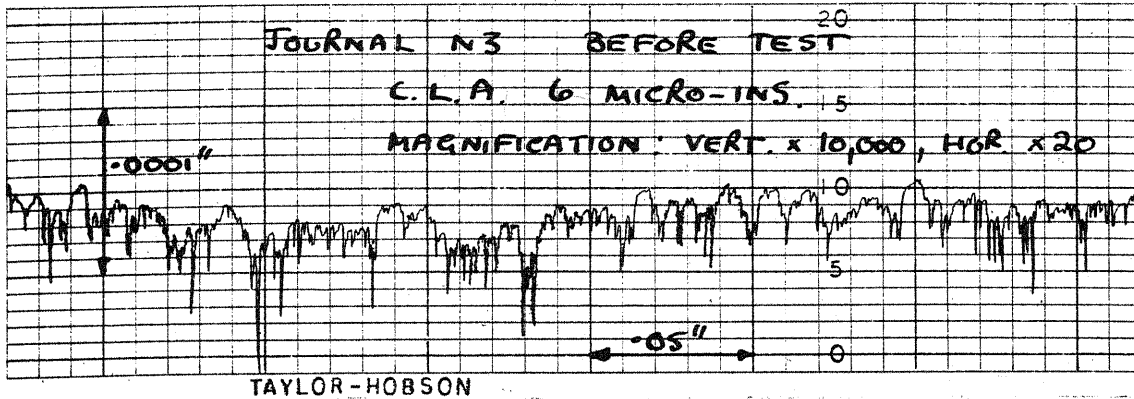

TALYSURF SURFACE ROUGHNESS RECORDS OF SOME OF THE NITRIDED STEEL JOURNALS BEFORE AND AFTER TEST.

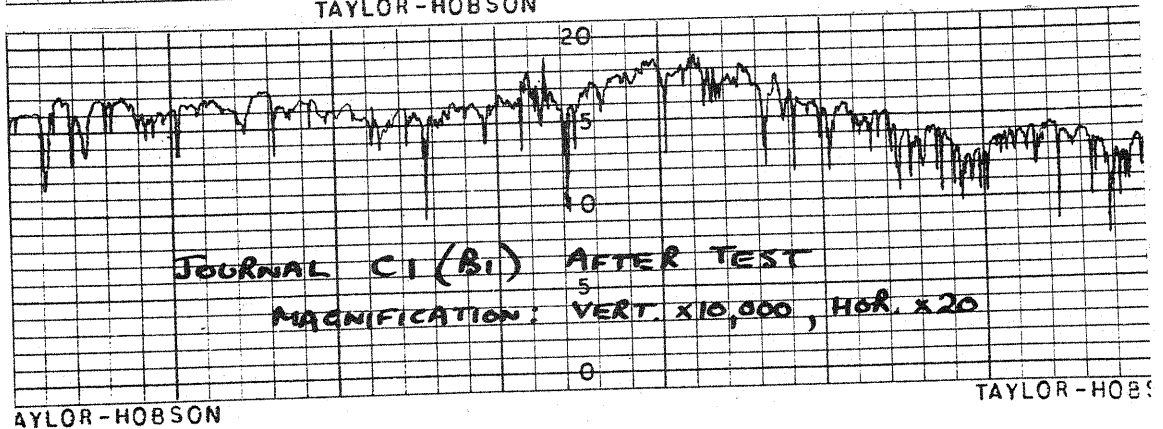
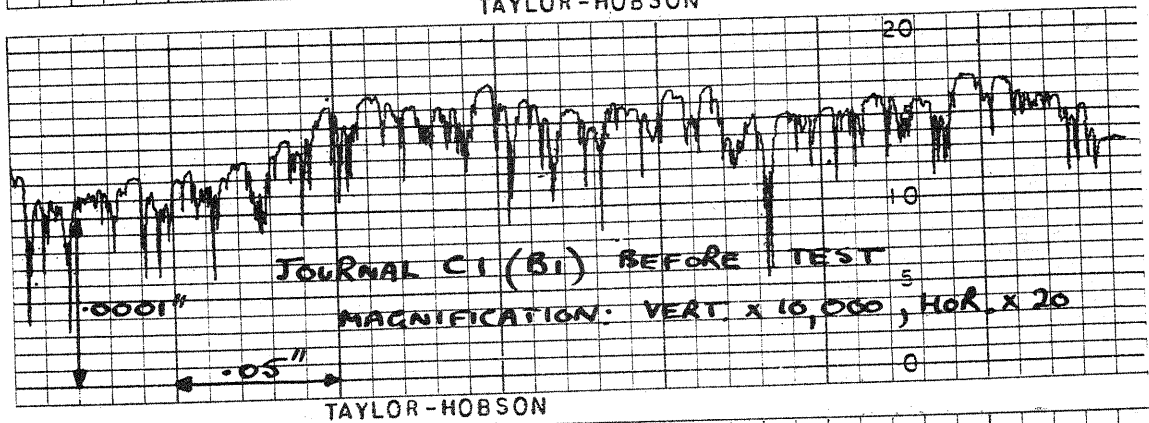
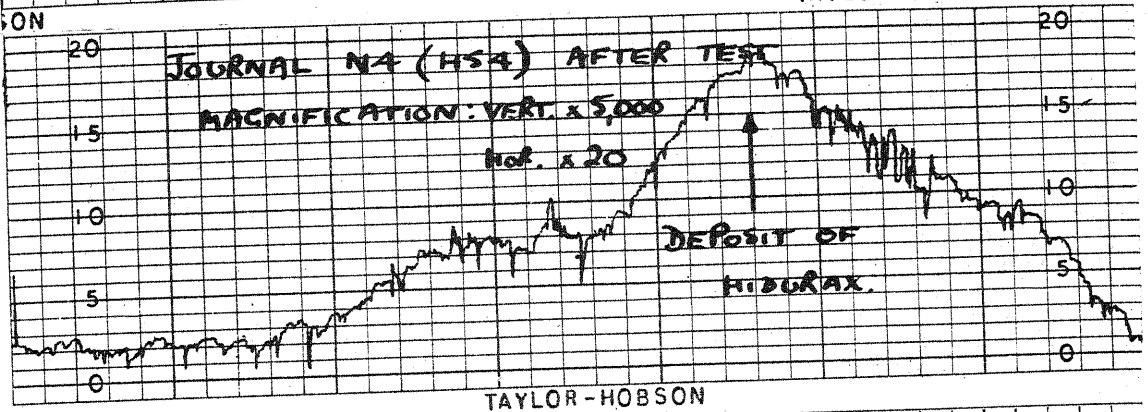
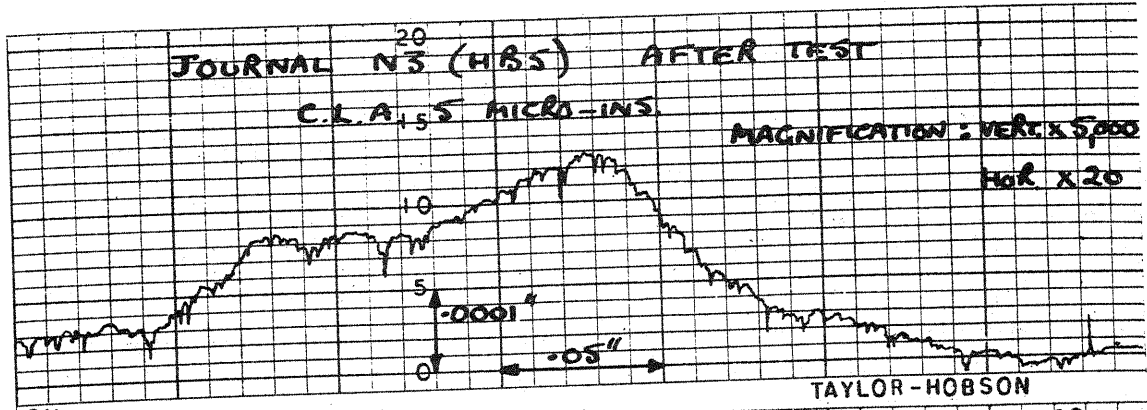

TALYSURF SURFACE ROUGHNESS RECORDS OF NITRIDED AND CASE-HARDENED JOURNALS BEFORE AND AFTER TEST.

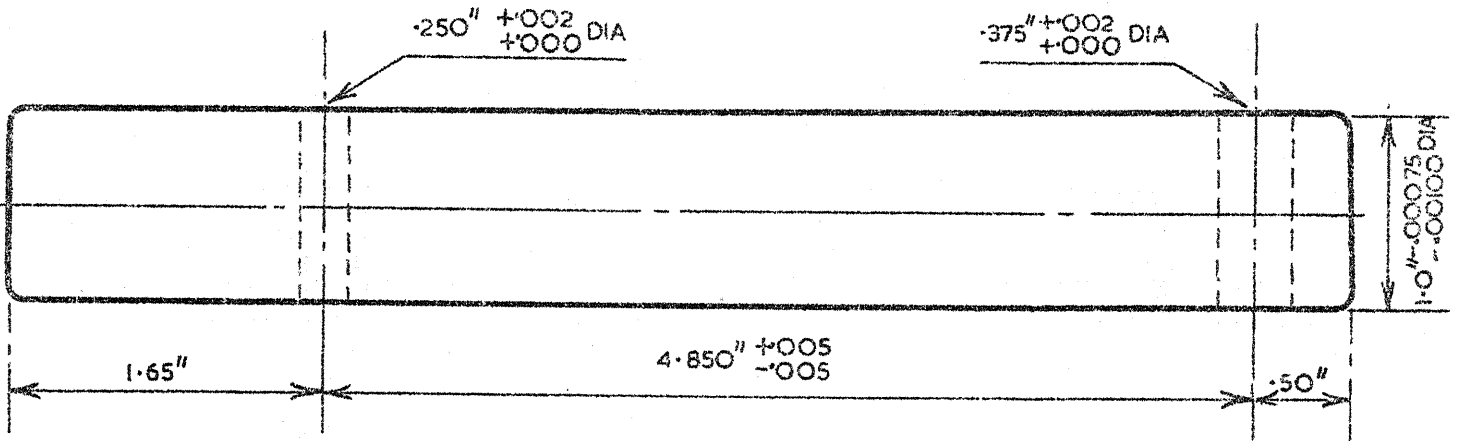

TEST JOURNAL

FIG. 12.

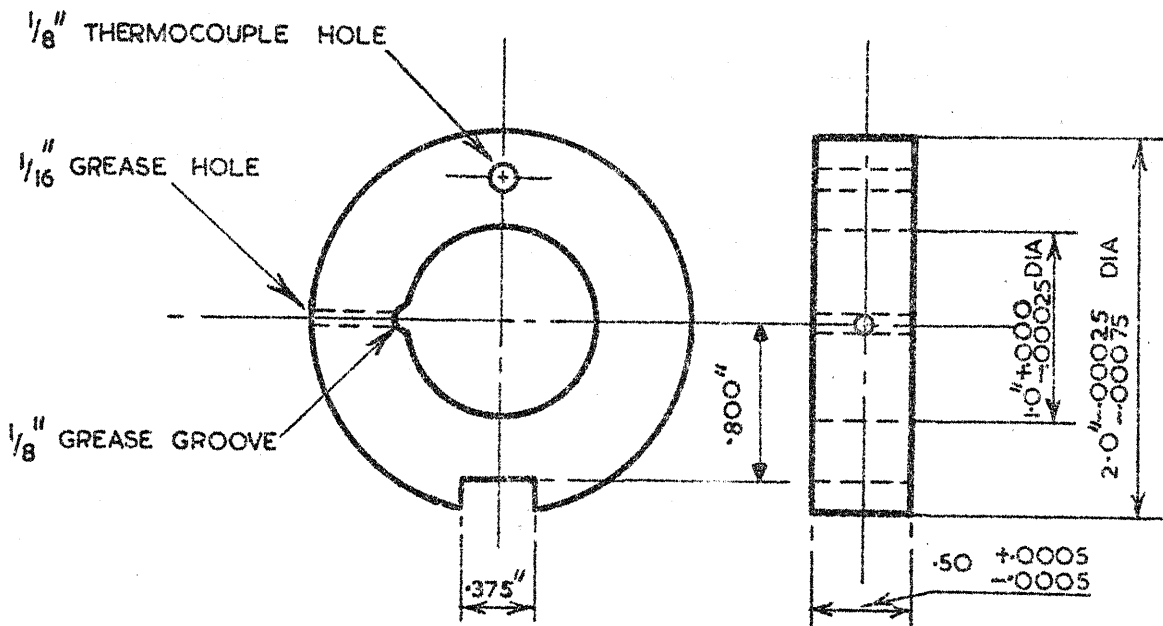

TEST BEARING

FIG. 13.

NOTE No. 12.

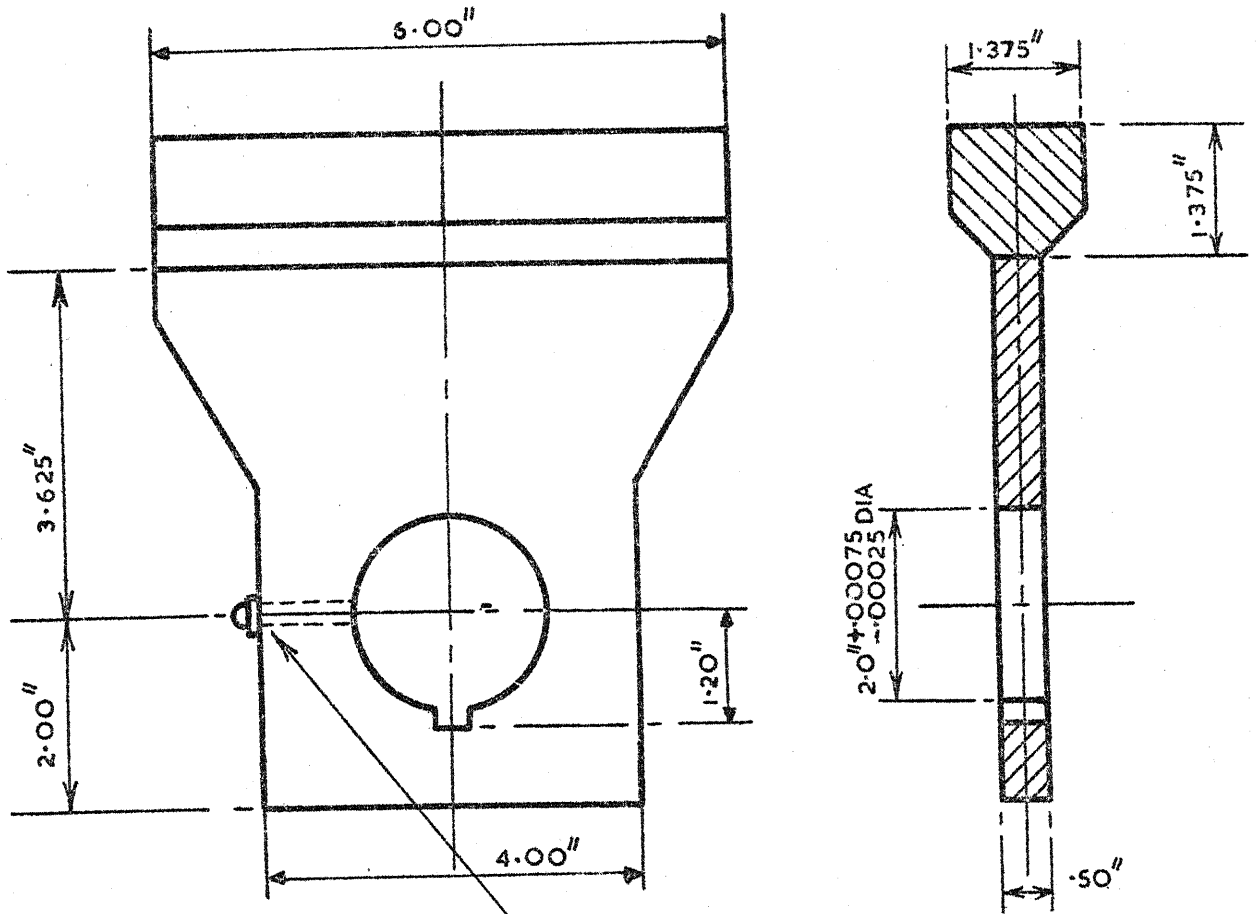

GREASE NIPPLE AND
 $\frac{1}{8}$ " GREASE HOLE

BEARING HOUSING.