

# Ultrasound-Induced CO<sub>2</sub>/H<sub>2</sub>O Emulsions as a Medium for Clean Product Formation and Separation: The Barbier Reaction as a Synthetic Example

Steven M. Cenci,<sup>†</sup> Liam R. Cox,<sup>‡</sup> and Gary A. Leeke<sup>\*,†</sup>

<sup>†</sup>School of Chemical Engineering, University of Birmingham, Edgbaston, Birmingham B15 2TT, United Kingdom

<sup>‡</sup>School of Chemistry, University of Birmingham, Edgbaston, Birmingham B15 2TT, United Kingdom

## Supporting Information

**ABSTRACT:** Subcritical CO<sub>2</sub>/H<sub>2</sub>O (30 °C/80 bar) was employed as a renewable solvent mixture in a 1 dm<sup>3</sup> ultrasound reactor. As a representative synthetic transformation, the metal-mediated Barbier allylation was used to demonstrate the facility of formation and separation of the homoallylic alcohol product. The chemoselectivity over the competing aldehyde reduction could be improved by deploying the biocompatible nonionic surfactant Tween 80, a saturated salt aqueous phase, or by carrying out the reaction at 60 °C/120 bar. All of these modifications led to an apparent rate increase in the desired allylation. A range of substituted benzaldehydes afforded the corresponding homoallylic alcohols in moderate to high yields. The presence of water constituted a necessary condition for efficient product formation, while CO<sub>2</sub> provided an appropriate phase for clean product separation by exploiting a favorable homoallylic alcohol enrichment. In this way, 0.025 mol of homoallylic alcohol product could be isolated from the CO<sub>2</sub> phase in 1 h, avoiding further extraction stages that would typically require organic solvents.

**KEYWORDS:** Carbon dioxide, Mixing, Emulsion, Mass transfer, Allylation, Aqueous media, Biphasic, Sonication, Kinetics

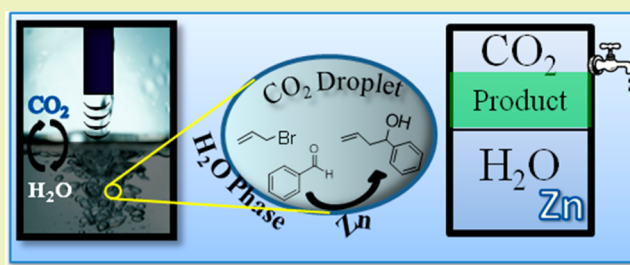

## INTRODUCTION

Owing to current economic, social, and environmental challenges, the manufacture of chemicals requires increased innovation at the chemistry/engineering interface.<sup>1</sup> As a consequence, the development of novel synthetic procedures, which focus on the use of inexpensive raw materials, higher energy efficiency, and improved separation and recovery of products, has become increasingly important.<sup>2</sup> As an example, biphasic CO<sub>2</sub>/H<sub>2</sub>O mixtures have attracted great interest as reaction solvent systems because the separation of products and catalysts can be facilitated by their preferential partitioning in either phase.<sup>3,4</sup> The solvating power of dense CO<sub>2</sub> for small apolar molecules,<sup>5,6</sup> as a liquid or supercritical fluid (at ≥30 °C/74 bar), combined with the polar nature of water, forms an ideal renewable solvent environment for solubilizing a wide range of molecules. Furthermore, the low mutual solubility of either solvent in the other allows hydrophobic and hydrophilic compounds to partition and separate at the CO<sub>2</sub>/H<sub>2</sub>O interphase.<sup>7</sup> Mixing of the phases may be implemented by ultrasound-induced dispersion.<sup>8</sup> Following separation of the aqueous phase and depressurization of the reactor, CO<sub>2</sub>-soluble species collect as a residue that is virtually solvent-free. Catalyst activity and recycling may be improved by designing specifically tagged compounds that can be trapped in either the CO<sub>2</sub> phase<sup>9–12</sup> or water phase<sup>13,14</sup> to facilitate their isolation and recovery. Reactions in a CO<sub>2</sub>/H<sub>2</sub>O biphasic system must in general

show tolerance to a moderately acidic medium (the reversible reaction between CO<sub>2</sub> and H<sub>2</sub>O generates carbonic acid, with a resulting pH of 3–4)<sup>15</sup> and to an aqueous environment.

A 1 dm<sup>3</sup> high-pressure ultrasound reactor was previously employed for evaluating the mass transfer of benzaldehyde and hydrolysis rates of benzoyl chloride in a CO<sub>2</sub>/H<sub>2</sub>O environment.<sup>16</sup> In the present study, the same reactor methodology was adopted for improving product separation and recovery in an important C–C bond-forming reaction, specifically the Barbier allylation of aldehydes to afford synthetically valuable homoallylic alcohols. It was envisaged that replacement of the organic–aqueous mixture with a CO<sub>2</sub>/H<sub>2</sub>O biphasic system would minimize the need for fossil-derived solvents and considerably reduce the material and energy required in subsequent work-up stages for separation/extraction of the product from the aqueous phase. Barbier reactions are operationally simpler than the corresponding Grignard reaction, allowing the one-step addition of an *in situ*-generated allyl nucleophile into an electrophile (typically an aldehyde) (Scheme 1).<sup>17</sup>

The reaction proceeds via nucleophilic attack by the allylmetal on the aldehyde to afford a synthetically versatile homoallylic alcohol product. Given the appeal of such

**Received:** February 18, 2014

**Revised:** March 31, 2014

**Published:** April 3, 2014

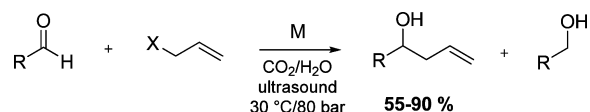
Scheme 1. Barbier Reaction<sup>a</sup>

<sup>a</sup>R = Ph, *p*-MePh, *p*-MeOPh, *o*-ClPh, (*E*)-PhCH=CH. X = Cl, Br. M = Zn, Sn, SnCl<sub>2</sub>.

reactions, efforts have been made to improve their industrial aspects, including the use of ionic liquids as solvents, continuous flow, and solvent-free conditions.<sup>18–20</sup> Indium and zinc have both been identified as efficient nontoxic metals, capable of mediating allylations in aqueous media. For example, the indium-mediated allylation of benzaldehyde has also been reported in liquid CO<sub>2</sub> in a 10 cm<sup>3</sup> reactor (82% yield of the homoallylic alcohol product after vigorous stirring for 48 h), although the reaction required a quenching step with concentrated hydrochloric acid *ex situ*.<sup>21</sup> In contrast, the method reported in this work offers the opportunity for the combined reaction (with shorter reaction times) and separation to be carried out *in situ*. Zinc dust has been previously shown to mediate efficient allylations in organic solvents and is a cheaper alternative to indium.<sup>22,23</sup> Therefore, we postulated that this metal would be a good choice for carrying out preliminary investigations into the Barbier allylation of aldehydes in a CO<sub>2</sub>/H<sub>2</sub>O biphasic.

## EXPERIMENTAL SECTION

**Reagents and Materials.** Allyl bromide [106-95-6], allyl chloride [107-05-1], allyl alcohol [107-18-6], benzaldehyde [100-52-7], 2-chlorobenzaldehyde [89-98-5], 4-methylbenzaldehyde [104-87-0], 4-methoxybenzaldehyde [123-11-5], (*E*)-3-phenylprop-2-enal [104-55-2], *n*-decane [124-18-5], Tween 80 [9005-65-6], zinc dust (<10 μm) [7440-66-6], tin powder (<100 μm) [7440-31-5], bismuth powder (100 mesh) [7440-69-9], tin(II) chloride dihydrate [10025-69-1], KI, NaCl, NaBr, NH<sub>4</sub>Cl, NaH<sub>2</sub>PO<sub>4</sub>, and KH<sub>2</sub>PO<sub>4</sub> were purchased from Sigma-Aldrich in >98% purity and used as received. Liquid CO<sub>2</sub> was supplied by BOC U.K., CP grade, with a given purity of 99.995%. Distilled water was used in all experiments. All valves, fittings, and tubes were purchased from Swagelok.

**Sonic Processor and Probe.** Ultrasound was generated by a 20 kHz VCX-1500 W processor (Sonics & Materials, CT, U.S.A.), coupled to a titanium alloy horn with tip diameter 1.9 cm. The amplitude setting could be varied 20–80%, while the pulse rate was 25% (1 s ON/3 s OFF) for all experiments. A calorimetric calibration allowed the intensity of the acoustic power dissipated to the fluid to be evaluated as approximately 70 W cm<sup>-2</sup>.

**General Procedure for Allylation Reactions in CO<sub>2</sub>/H<sub>2</sub>O.** The experimental setup is depicted in Figure 1. A high-pressure reactor (Parr, U.S.A.) consisting of a cylindrical 1 dm<sup>3</sup> stainless steel vessel modified for ultrasound (item 6) was utilized for the Barbier reactions. In order to avoid any reaction from taking place during CO<sub>2</sub> addition, as might happen were all of the reagents to be added to the reactor at the outset, the aldehyde or the aldehyde/allyl halide mixture was injected (via item 5) into the pressurized CO<sub>2</sub>/H<sub>2</sub>O mixture containing the metal.

The reactor was heated by an electric heating jacket (temperature controller Parr 4838 with J type thermocouple in a reactor thermowell) until the desired temperature was reached. In a typical experiment, zinc dust (8 g, 122 mmol), allyl bromide (10.6 mL, 122 mmol), *n*-decane (as an internal standard, 0.5 mL, 2.5 mmol), and H<sub>2</sub>O (580 mL) were added to the reactor. The vessel was sealed and charged with CO<sub>2</sub> to the desired pressure. CO<sub>2</sub> was delivered to the reactor at a flow rate of ~40 g min<sup>-1</sup> via a high-pressure pump, P1, (Thar Instruments), electronically connected to a PC. The amount of CO<sub>2</sub> entering the reactor was recorded via a mass flow meter

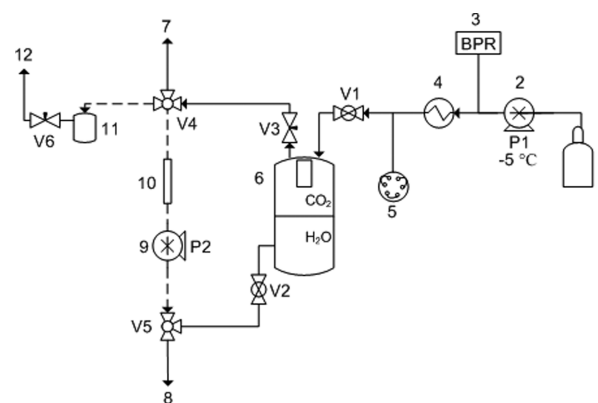

**Figure 1.** Process flow diagram showing the system employed for the study of the Barbier reaction in CO<sub>2</sub>/H<sub>2</sub>O. (1) CO<sub>2</sub> cylinder, (2) CO<sub>2</sub> pump (P1), (3) automatic back-pressure regulator (BPR), (4) heat exchanger, (5) six-port valve for injection of reagents through the reactor inlet (V1), (6) 1 dm<sup>3</sup> ultrasound reactor, (7) CO<sub>2</sub> sample collection valve (V4), (8) H<sub>2</sub>O sample collection valve (V5), (9) bypass line for visualization of CO<sub>2</sub>/H<sub>2</sub>O dispersions through the pyrex tube (10) via pump P2, (11) view cell for collection of CO<sub>2</sub> fraction, and (12) CO<sub>2</sub> gas vent.

(Rheonik) positioned in-line before the pump. PhCHO (61 mmol) was injected into the flowing CO<sub>2</sub> stream via a six-port valve fitted with a bypass tube of known volume (6.22 mL or 16.22 mL when both reagents were coinjected). Ultrasound was immediately commenced, and the contents were sonicated for the required time. Water cooling was employed with a peristaltic pump (Watson–Marlow) so that isothermal conditions could be maintained throughout the experiment. Upon completion of the reaction at 60 °C/120 bar, the CO<sub>2</sub> density (0.43 g cm<sup>-3</sup>) was increased by quickly cooling the reactor with cold water to 30 °C/80 bar (0.7 g cm<sup>-3</sup>) and continuing sonication for 1 h, in order to maintain constant CO<sub>2</sub> solvation during the separation stage and therefore remove bias due to differences in solubility.

For macroscopic visualization of CO<sub>2</sub>/H<sub>2</sub>O dispersions generated by ultrasound, the reactor contents were circulated through a pyrex tube at a flow rate of 20 cm<sup>3</sup> min<sup>-1</sup> by a dual piston HPLC pump (Jasco PU-2087). The pyrex tube (OD = 8 mm) high-pressure connection was achieved by bonding the inside wall of the pyrex to a 1/16 in. PEEK tube using Araldite adhesive.

**Sampling and Analysis.** After stopping sonication, samples originating from the CO<sub>2</sub> phase were slowly bubbled through cold acetone by opening valves V3 and V4. The pressure was kept constant between each sampling by topping with fresh CO<sub>2</sub> through the use of the BPR. A heating coil wrapped around the depressurization tube (Barnstead electrothermal regulator) prevented freezing of the contents due to expansion of CO<sub>2</sub>. Aqueous samples were taken from a line originating from a 14 cm 1/4 in. stainless steel dip tube immersed in the reactor. In order to minimize the presence of particulates in the samples, two sintered filters (Swagelok, 0.5 μm pore) were fitted in-line with each sampling tube. Following depressurization of the reactor, samples were also taken from the aqueous suspension (50 mL) and were Buchner filtered and washed with Et<sub>2</sub>O (20 mL) and the filtrate extracted with Et<sub>2</sub>O (2 mL × 50 mL). Aliquots taken from each sample were analyzed by gas chromatography (Shimadzu GC-2010, with autosampler and injector AOC-20, equipped with a DB-5 column and an FID). Calibrations with the respective product and PhCHO standards allowed for calculation of the yields and selectivities. The yields of homoallylic alcohol products arising from other aldehydes were calculated by the GC conversion relative to the unreacted starting aldehyde. The fractions containing the desired homoallylic alcohol product were concentrated in vacuo and analyzed by <sup>1</sup>H NMR (at 300 MHz) and <sup>13</sup>C NMR spectroscopy (at 100 MHz). Data were identical to those reported in the literature (Supporting Information).

**Product Separation.** A 30 cm<sup>3</sup> high-pressure stainless steel view cell ID = 2.5 cm, H = 5.7 cm (Parr Instruments, Moline, IL, U.S.A.), fitted with two in-line sapphire windows (D = 1.5 cm) (item 10, Figure 1), was connected to the ultrasound reactor (item 7, Figure 1) and kept between 30–40 °C by two electric heating plates connected to a dedicated controller and monitored by an immersed J type thermocouple. Two valves were positioned in line in order to control the CO<sub>2</sub> flowing into and venting out of the cell. Each cycle may be summarized as follows. The valve before the cell (Metering valve, Swagelok) was slowly opened so that the pressure in the cell did not exceed 30 bar. The resulting pressure drop in the ultrasound vessel was rectified by topping up with CO<sub>2</sub>. The valve after the cell was slowly opened to vent CO<sub>2</sub> gas, while the condensate crude oil product remained in the cell. Following ~1 h of separation cycles, the crude oil was collected and weighed in a preweighed glass vial. An aliquot was dissolved in acetone and analyzed by GC.

## RESULTS AND DISCUSSION

Ultrasonic irradiation of the liquid CO<sub>2</sub>/H<sub>2</sub>O mixture generated a fine emulsion that lasted for several minutes (Figure 2).

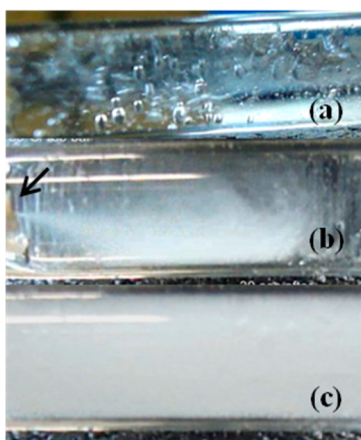

**Figure 2.** Observation of CO<sub>2</sub>/H<sub>2</sub>O (40 v/v%) mixtures flowing through a pyrex tube following sonication in the ultrasound vessel. (a) 25 °C/60 bar (CO<sub>2</sub> = vapor); only macroscopic bubbles are observed following several minutes of sonication. (b) 25 °C/75 bar (CO<sub>2</sub> = liquid); a fine dispersion enters the chamber from the inlet PEEK tube (arrow) a few seconds after commencing sonication. (c) Same as in (b); approximately 2 min after stopping sonication, turbidity completely obscures the tube. Pyrex tube OD = 8 mm.

Ultrasound in the presence of CO<sub>2</sub> is not expected to lead to “true” sonochemical effects arising as a consequence of the high

temperatures generated during adiabatic compression of cavitation bubbles.<sup>24</sup> This is due to the low ratio of specific heats,  $\gamma$ , for CO<sub>2</sub> compared to the high ratios observed for mono- and diatomic gases. Nevertheless, cavitation in the presence of a liquid CO<sub>2</sub>/H<sub>2</sub>O mixture will lead to physical effects such as emulsion formation, which may have important implications in relation to mixing and mass transfer phenomena. Indeed, we showed that sonication increased the mass transfer rate of benzaldehyde from CO<sub>2</sub> to water by 2 orders of magnitude relative to the “silent” case (without sonication or any other form of agitation).<sup>16</sup>

An initial investigation using benzaldehyde and allyl bromide found that commercially available zinc dust could be employed in CO<sub>2</sub>/H<sub>2</sub>O mixtures at 30 °C/80 bar, affording moderate to high yields of the desired homoallylic alcohol product within 2 h (Table 1). Failure of the reaction to initiate under “silent” conditions (Table 1, entry 1) supported our previous observations, further illustrating the importance of ultrasound for effecting a reaction through improved mixing of the biphasic.

In aqueous allylation reactions, the formation of the homoallylic alcohol product may be blocked by competing protodemetalation of the *in situ*-generated allyl metal species.<sup>23</sup> Indeed, this competing reaction presumably accounts for the observation that when the allyl bromide/zinc mixture was sonicated for 1 h before adding benzaldehyde to the reactor, the homoallylic alcohol product was not observed despite observing disappearance of the allyl bromide (by GC analysis). Fortunately, protodemetalation did not compete with the desired allylation when the reaction was performed under typical Barbier conditions (one-step addition of both reagents to the vessel containing the metal). However, a competing reaction was the metal-mediated reduction of benzaldehyde to benzyl alcohol. The formation of the reduction product has been ascribed to the reaction of the reduced aldehyde radical anion with water.<sup>25</sup> The reduced product was not observed in allylations, which were carried out at atmospheric pressure in only water, suggesting that Brønsted acid catalysis by carbonic acid could enhance this reduction pathway. In support of this, carbonic acid has been previously successfully exploited as a proton source for the zinc-mediated reduction of nitroarenes in a CO<sub>2</sub>/H<sub>2</sub>O mixture.<sup>26</sup> Fortuitously, in the present system, the benzyl alcohol reduction product was present in only trace amounts in the CO<sub>2</sub> phase compared with the homoallylic alcohol product. The partition coefficient of benzyl alcohol in CO<sub>2</sub>/H<sub>2</sub>O is much lower than its octanol/H<sub>2</sub>O equivalent ( $K_{CW} = 0.5$  and  $K_{OW} = 12.6$ , based on molar concentration).<sup>27</sup>

**Table 1. Zinc-Promoted Allylation of Benzaldehyde by Allyl Bromide**

entry	Zn/allyl bromide/PhCHO (molar ratio)	salt (mol eq)	conditions <sup>a</sup>	homoallylic alcohol % yield <sup>b</sup> (selectivity) <sup>c</sup>
1	2:2:1	–	30 °C/80 bar, no ultrasound	traces
2	2:2:1	–	30 °C/80 bar CO <sub>2</sub> only	26 (100)
3	2:2:1	–	30 °C/80 bar	67 (74)
4	2:2:1	–	60 °C/120 bar	78 (87)
5	2:2:1	NaCl (satd.)	30 °C/80 bar	90 (95)
6	2:2:1	NH <sub>4</sub> Cl (satd.)	30 °C/80 bar	93 (99)
7	1:1:1	NH <sub>4</sub> Cl (6)	30 °C/80 bar	41 (91)
8	1:1:1	–	30 °C/80 bar	37 (60)
9	2:1.5:1	–	30 °C/80 bar	55 (64)

<sup>a</sup>Typical conditions: benzaldehyde (61 mmol), allyl bromide (120 mmol), zinc dust (120 mmol), CO<sub>2</sub>/H<sub>2</sub>O = 40 v/v %, ultrasound 80% amplitude, 25% pulse rate, and reaction time = 2 h. <sup>b</sup>Yields % determined by GC relative to the internal standard. <sup>c</sup>Selectivity assessed by yield/benzaldehyde conversion (other major product was benzyl alcohol).



On the other hand, for the homoallylic alcohol product, the “apparent”  $K_{CW}$  was 9. Together with its higher yield, this led to an advantageous enrichment of the desired allylation product compared with the primary alcohol reduction product in the  $\text{CO}_2$  phase.

Surfactants may be employed in water as a method for replacing the organic phase while increasing the surface area over which reactions take place.<sup>28</sup> If the rate-determining step occurs at the interface, rate enhancements may potentially be observed under conditions that generate higher interfacial areas.<sup>29</sup> In order to explore whether the reaction could be improved under conditions of increased interfacial area, the progress of the allylation was monitored over time in the presence and absence of 1 wt % Tween 80, a biocompatible nonionic surfactant. Surfactant-free  $\text{CO}_2/\text{H}_2\text{O}$  emulsions, generated by ultrasound, have been shown to form simultaneous C/W (where the  $\text{CO}_2$  phase is dispersed in the  $\text{H}_2\text{O}$  phase) and W/C (where the  $\text{H}_2\text{O}$  phase is dispersed in the  $\text{CO}_2$  phase) environments, with droplets ranging between 9–15  $\mu\text{m}$  in diameter and the volume fraction of each phase dispersed in the other being between 5–10%.<sup>30</sup> The inclusion of surfactants in the  $\text{CO}_2/\text{H}_2\text{O}$  systems also allows the formation of emulsions or microemulsions by stabilizing the repulsive forces between the droplets.<sup>31</sup> Due to the quadruple moment of  $\text{CO}_2$  and higher miscibility with  $\text{H}_2\text{O}$ , a lower interfacial tension exists between  $\text{CO}_2$  and  $\text{H}_2\text{O}$  ( $<20 \text{ mN m}^{-1}$ ) than between alkanes and  $\text{H}_2\text{O}$  ( $30\text{--}50 \text{ mN m}^{-1}$ ).<sup>32,33</sup> As a consequence,  $\text{CO}_2/\text{H}_2\text{O}$  emulsions may be formed with only 0.1–2 wt % surfactant. The type of surfactant employed dictates the nature of the emulsion formed, and one entire phase may be dispersed in the continuous phase depending on the initial volume of each phase present. For example, fluorinated surfactants have been used to stabilize W/C emulsions and have been shown to increase the rate of the hydrogenation of styrene.<sup>34,35</sup> Tween 80 has been shown to stabilize C/W emulsions at relatively low temperatures and pressures forming droplets of  $\sim 0.5\text{--}5 \mu\text{m}$  in diameter.<sup>36</sup> The emulsion droplet size was controlled by passing the  $\text{CO}_2/\text{H}_2\text{O}$  mixture at different flow rates through a sand pack with pore diameters of 10  $\mu\text{m}$ . Although droplet diameter was not investigated in the present work, the use of pulsed ultrasound compared to other methods of emulsification could provide several advantages, including an increase in the number and persistence of spatial reactive sites during the OFF stage of the cycle. In a previous study, we showed that ultrasound-induced mixing of the  $\text{CO}_2/\text{H}_2\text{O}$  biphasic system in the presence of 1 wt % Tween 80 led to a 10-fold increase in the mass transfer-limited rate of benzoyl chloride hydrolysis relative to emulsions that were only stabilized by ultrasound.<sup>16</sup> The presence of Tween 80 conferred greater stability on the emulsion, which persisted for over 1 h.

A  $\text{CO}_2/\text{H}_2\text{O}/1 \text{ wt } \%$  Tween 80 system showed a similar improvement in the rate of allylation, providing quantitative yields of the desired product in 2 h (Figure 3).

Most noticeably, in the presence of Tween 80, the chemoselectivity of the reaction was dramatically improved, with the homoallylic alcohol product now being formed in  $>95\%$  selectivity. Studies have demonstrated the partitioning of aromatic compounds in the hydrophobic core of microemulsions with reduced presence in the proximity of the ethylene oxide groups of the surfactant.<sup>37</sup> In the present case, benzaldehyde and allyl bromide would be transported from the  $\text{CO}_2$  core to the interface, where more polar species reside.

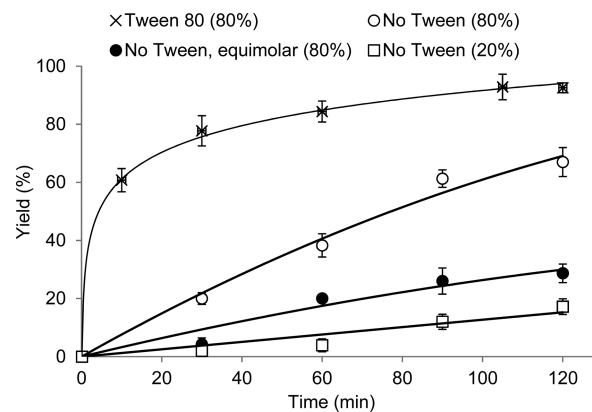

**Figure 3.** Time course for the formation of the homoallylic alcohol product in the presence and absence of Tween 80, with the respective ultrasound amplitude values showing (%). Conditions:  $\text{CO}_2/\text{H}_2\text{O} = 40 \text{ v/v } \%$ , and  $30 \text{ }^\circ\text{C}/80 \text{ bar}$ . The reactions were carried out with zinc/allyl bromide/benzaldehyde molar ratios of 2:2:1 unless stated otherwise.

Tween 80 has also been employed as an efficient ionophore<sup>38</sup> and as a phase-transfer catalyst for several reactions.<sup>39,40</sup> The ability of Tween 80 to remove the mass transfer resistance by increasing the interfacial area is indicated by faster rates in its presence.

In assessing the extent of the physical limitations of a reaction, it is often appropriate to identify the Hatta number,  $Ha$ , which is defined as the ratio of maximum reaction rate to diffusion rate<sup>41,42</sup>

$$Ha = \frac{\sqrt{D_A \times k_{\text{irr}}}}{k_w} \quad (\text{eq 1})$$

where  $D_A$  is the diffusivity,  $k_{\text{irr}}$  is the intrinsic rate constant, and  $k_w$  is the mass transfer coefficient on the water side.  $D_A$  for most organic compounds in liquids is in the order of  $1 \times 10^{-5} \text{ cm}^2 \text{ s}^{-1}$ . The intrinsic rate constant,  $k_{\text{irr}}$ , may be evaluated by taking the pseudo-first-order rate constants for the allylation step ( $0.2\text{--}1.2 \times 10^{-3} \text{ s}^{-1}$ , depending on allyl bromide, benzaldehyde and catalyst concentrations).<sup>43,44</sup> Because these zinc-mediated allylations occur much faster in aqueous media, the reaction may be assumed to occur in the  $\text{H}_2\text{O}$  phase rather than in the  $\text{CO}_2$  phase, and thus, the mass transfer coefficient was modeled on benzaldehyde going from the  $\text{CO}_2$  to the  $\text{H}_2\text{O}$  side ( $k_w = 1.5 \times 10^{-4} \text{ cm s}^{-1}$  for the silent case and with an effective mass transfer coefficient due to sonication  $>1.9 \times 10^{-3} \text{ s}^{-1}$ ).<sup>16</sup> Inserting these values into eq 1 generated  $Ha$  of 0.3–0.75, indicative of a slow reaction (only reactions with  $Ha > 2$  are considered fast with a high dependence on mass transfer resistance). A comparison of the effective mass transfer coefficient and  $k_{\text{irr}}$  revealed that both time scales approximated each other, indicating that the allylation is unlikely to be diffusion limited. An additional improvement to  $k_{\text{orr}}$  (defined as the observed rate constant) was offered by the inclusion of Tween 80. Unlike for fast reactions such as the hydrolysis of benzoyl chloride, where the inclusion of Tween 80 led to a 10-fold increase in  $k_{\text{orr}}$  ( $k_{\text{orr}}$  was still almost 100 times slower than in pure water,  $k_{\text{irr}} = 1.2 \text{ s}^{-1}$ ),<sup>16</sup>  $k_{\text{orr}}$  for the allylation reaction in the presence of Tween 80 only led to a 4-fold rate increase, indicating that ultrasound was more likely to favor well-mixed conditions for the allylation reaction than for the hydrolysis

reaction (i.e., conditions in which diffusion from CO<sub>2</sub> to H<sub>2</sub>O reach equilibrium).

We found that the chemoselectivity in favor of the allylation product could also be improved by performing the reaction at 60 °C/120 bar (Table 1, entry 4) or by the inclusion of salts (Table 1, entries 5–6). Recently, zinc-mediated allylations have been usefully employed as a method for obtaining a range of biologically active compounds.<sup>45</sup> Furthermore, an aqueous salt phase has been shown to greatly reduce reaction time in these allylations.<sup>46</sup> The role of salts in the Barbier reaction has been shown to depend on the nature of the halide anion used,<sup>47</sup> and although uncertain, it is thought that their presence may be responsible for activation of the metal through interaction of anionic species (most frequently chloride ions) with the passive oxide film.<sup>48</sup> Inclusion of an aqueous phase, saturated with either NaCl or NH<sub>4</sub>Cl, led to increased chemoselectivities in favor of the homoallylic alcohol product. The effect of salts on the rate was further investigated by varying the counteranion, counteranion, and salt concentration (Figure 4). A pseudo-first-order relationship with respect to benzaldehyde was assumed.<sup>49</sup>

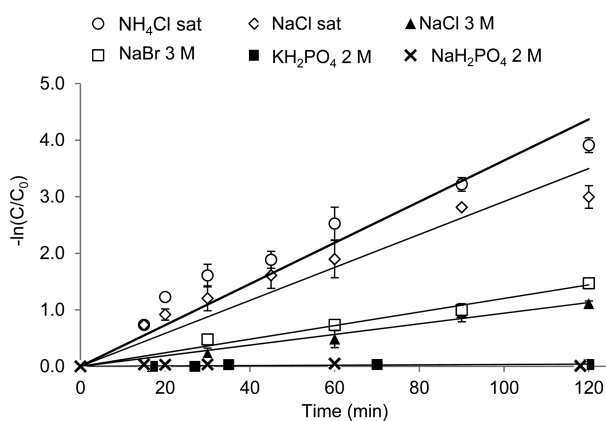

**Figure 4.** First-order kinetics plot for the zinc-mediated allylation of benzaldehyde using allyl bromide in CO<sub>2</sub>/H<sub>2</sub>O in the presence of different salts.

Inclusion of saturated solutions of NaCl and NH<sub>4</sub>Cl resulted in improved chemoselectivity, with the allylation rate being between 2 and 4 times higher than when just water was employed as the aqueous phase. The use of a 3 M NaCl solution as the aqueous phase led to a lower rate of allylation, suggesting that the chemoselectivity may depend on the salt concentration. In order to rule out any specific mechanistic involvement by the chloride counteranion, 3 M NaBr was also tested as the aqueous phase; however, a similar result was observed. Interestingly, when the counteranion was dihydrogen phosphate, the chemoselectivity was reversed in favor of the reduction product. This particular effect could be related to the pH of the reaction mixture, which was significantly lower in samples containing the dihydrogen phosphates than with the halide salts (pH 4.0–4.4 with the dihydrogen phosphates compared to 5.6–6.9 with the halides).

CO<sub>2</sub>/H<sub>2</sub>O/salt systems are of high environmental significance in geological sequestration and enhanced oil recovery techniques. The presence of salts had a salting-out effect on the homoallylic alcohol product, producing a decrease in its concentration in the aqueous phase and an increase in the CO<sub>2</sub> phase (Figure 5). The literature describing quaternary systems of CO<sub>2</sub>/H<sub>2</sub>O/salt/solute is scarce. Wagner et al.

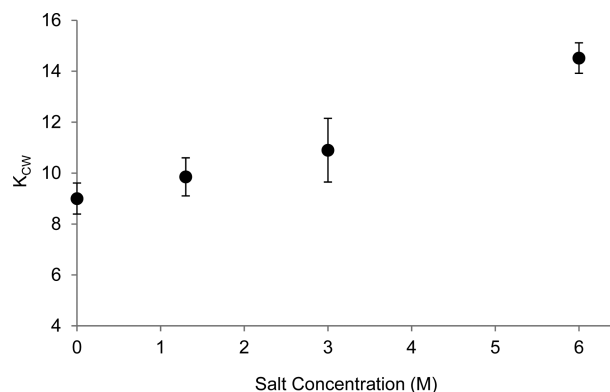

**Figure 5.** Effect of salt concentration on homoallylic alcohol  $K_{CW}$  following zinc-mediated allylations in CO<sub>2</sub>/H<sub>2</sub>O. Conditions: CO<sub>2</sub>/H<sub>2</sub>O = 40 v/v %, 30 °C/80 bar, and ultrasound amplitude 80%.

reported a 2.7-fold increase in the  $K_{CW}$  of phenol when NaCl was included at ~3 M.<sup>50</sup> Sieder and Maurer observed a salting-out effect and a 2-fold increase in the  $K_{CW}$  of acetic acid when NaCl was included at 1.5 M.<sup>51</sup> Similarly, the  $K_{CW}$  of the homoallylic alcohol product showed a 1.6-fold increase with the inclusion of NaCl up to 6 M. The reduced effect observed, compared to that reported for phenol and acetic acid, may be due to the homoallylic alcohol being more hydrophobic than these compounds and experiencing a less marked change in the solubilities of both phases.

In order to investigate if the reduction side-reaction was influenced by the choice of metal, the Barbier reaction was next assessed with tin metal. Tin is a useful promoter for several synthetic transformations.<sup>52</sup> While it possesses a lower first ionization energy than zinc, its use in allylation reactions has been shown to require prior activation by inorganic acids<sup>53</sup> or ultrasound,<sup>54,55</sup> through the use of tin nanoparticles,<sup>56,57</sup> or its use in combination with salts such as NaBF<sub>4</sub>.<sup>58</sup> In the present system, allylation was only observed when tin metal was employed at 60 °C/120 bar (Table 2).

**Table 2.** Allylation with Benzaldehyde and Allyl Bromide and Tin

entry	M	salt (mol eq)	conditions <sup>a</sup>	homoallylic alcohol % yield <sup>b</sup> (selectivity)
1	Sn	—	30 °C/80 bar	—
2	Sn	—	60 °C/120 bar	34 (100)
3	Sn	NaCl (18)	60 °C/120 bar	73 (100)
4	Bi	—	60 °C/120 bar	—

<sup>a</sup>Conditions: M/allyl bromide/aldehyde 1:1:1 (based on 61 mmol of benzaldehyde); CO<sub>2</sub>/H<sub>2</sub>O = 40 v/v %, ultrasound 80% amplitude, 25% pulse rate, and reaction time = 2 h. <sup>b</sup>Yields determined by GC relative to internal standard.

The addition of NaCl significantly improved the yield of the homoallylic alcohol product at this temperature and pressure, indicating that these two factors may be working in synergy. Thus, in the presence of NaCl at 60 °C/120 bar, tin metal could be used with the other two reagents in equimolar ratios. Bismuth has recently attracted attention as a safer alternative to tin for mediating Barbier reactions; however, even at 60 °C/120 bar, bismuth powder did not lead to any product formation.

The reactions were next performed with different allyl reagents and a range of substituted aromatic aldehydes (Table 3). In order to improve the cost efficiency of the reaction,

Table 3. Allylation Reactions with Various Allylic Compounds and Aldehydes

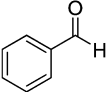
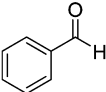
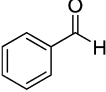
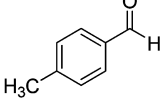
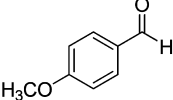
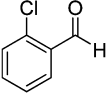
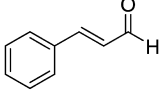
entry	aldehyde	X	homoallylic alcohol product <sup>a</sup>	conditions <sup>b</sup>	homoallylic alcohol %yield <sup>c</sup> (selectivity)
1		Br	<b>1a</b>	Zn Zn/NaCl	67 (74) 90 (95)
2		Cl	<b>1a</b>	SnCl <sub>2</sub> /KI	47 (100)
3		OH	<b>1a</b>	SnCl <sub>2</sub> /KI	-
4		Br	<b>2a</b>	Zn Zn/NaCl	60 (95) 70 (95)
5		Br	<b>3a</b>	Zn Zn/NaCl	55 (61) 85 (94)
6		Br	<b>4a</b>	Zn Zn/NaCl	90 (95) 80 (72)
7		Br	<b>5a</b>	Zn Zn/NaCl	71 (80) 82 (93)

<sup>a</sup>Numbers refer to each product as defined in the Supporting Information. <sup>b</sup>Entries 2–3: Performed with SnCl<sub>2</sub>/KI 0.06/0.3 (mol) at 60 °C/120 bar; all other reactions were performed at 30 °C/80 bar. Conditions: zinc/allyl reagent/aldehyde 2:2:1 (based on 61 mmol of benzaldehyde), CO<sub>2</sub>/aq = 50 v/v %, ultrasound 80% amplitude, 25% pulse rate, and reaction time = 2 h. <sup>c</sup>Entries 4–7 determined by GC conversion.

cheaper allyl chloride would be preferred over allyl bromide, even if this were at the expense of longer reaction times.<sup>59</sup> Unfortunately, in the present case, the reaction did not proceed satisfactorily with allyl chloride, and most of the benzaldehyde underwent preferential reduction. The inclusion of sodium or potassium iodide can be used to improve the conversion of allyl chloride in the Barbier reaction, with iodide participating in a Finkelstein reaction with the allyl chloride, generating the more reactive allyl iodide in situ. Indeed, allyl chloride was able to form the homoallylic alcohol product, albeit in moderate amounts, when SnCl<sub>2</sub>/KI was employed at 60 °C/120 bar; however, this offers no synthetic advantage over the use of allyl bromide. The use of allyl alcohol did not lead to any product formation even under forcing conditions. The allylation reaction proceeded efficiently with various other aromatic aldehydes (Table 3, entries 4–7). Aromatic aldehydes were chosen as examples as they are the most structurally relevant substrates for many applications. Indeed, they form >90% of all substances entering the R&D programs of major pharmaceutical companies.<sup>60</sup>

4-Methylbenzaldehyde showed lower reactivities for the allylation and reduction reactions (entry 4), while 4-methoxybenzaldehyde also exhibited lower chemoselectivity for the homoallylic alcohol product (entry 5). With both substrates, the yield and selectivity could again be improved by including NaCl in the aqueous phase. The reaction with the more electrophilic 2-chlorobenzaldehyde generated a high yield of the corresponding homoallylic alcohol product, even in the absence of NaCl (entry 6). Finally, the reaction with (*E*)-

cinnamaldehyde (entry 7) occurred regioselectively, affording the 1,2-addition compound as the major product.

The ability to recover products from dense CO<sub>2</sub> as an immiscible counter phase is of significant interest in reaction or extraction procedures.<sup>61</sup> Separation procedures are highly flexible in CO<sub>2</sub>/H<sub>2</sub>O biphasic systems, as either the water phase or the CO<sub>2</sub> phase may be recovered. In an industrial setting, an ideal strategy would involve complete discharge of the metal-containing aqueous phase at constant pressure through an opening in the bottom of the vessel, followed by isolation of the product by depressurization and compression and recirculation of the CO<sub>2</sub> vent. However, such an opening was not present in our reactor, so that the aqueous phase could only be collected through a dip tube, potentially leading to unwanted mixing of the product with any remaining water present at the bottom of the reactor during depressurization. The product was therefore isolated by passing the CO<sub>2</sub> fraction into the view cell (item 11, Figure 1). In order to ensure removal of any water present in the CO<sub>2</sub> phase and to facilitate emulsion breakdown, 50 mL of water was slowly collected by opening valves V2 and V5, while the reactor pressure was maintained between 80–100 bar via pump P1. The product containing the CO<sub>2</sub> fraction was passed into the view cell, the pressure of which was controlled below 30 bar with valves V4 and V6 to ensure that the CO<sub>2</sub> in the view cell was in gaseous form and did not carry any product when vented from the outlet. An additional automated back pressure regulator in place of valve V4 would simplify this procedure and significantly reduce operating time. The colorless crude product



mixture, which was condensing in the view cell, was monitored by observing the position of the meniscus through the windows. By following this separation procedure, the isolated yield for the homoallylic alcohol product from the zinc-mediated allylation of benzaldehyde by allyl bromide was 76% and 58% in the presence and absence of salt, respectively. Collecting all of the fractions and extracting the aqueous phase with Et<sub>2</sub>O led to improved isolated yields of 88% (with salt) and 64% (without). The differences observed between these isolated product yields obtained by the “*in situ* separation” method and the more traditional extraction method using an organic solvent may be ascribed to residual product losses to the water phase during depressurization. Furthermore, following experiments in which salt was included, the top CO<sub>2</sub> fraction contained roughly 10 wt % of water, possibly arising as a result of enhanced stability of the CO<sub>2</sub>/H<sub>2</sub>O/salt emulsion. Therefore, further studies would be required to assess the stability of these salt-containing dispersions and improve their breakdown for more efficient recovery of the product.

Finally, it was estimated that by exploiting the tunable solvent power of CO<sub>2</sub> over a range of temperatures and pressures, the solubility of benzaldehyde could potentially increase up to 7-fold (from 0.025–0.18 g g<sup>-1</sup> at 100 °C/200 bar),<sup>62</sup> allowing ~0.85 mol of benzaldehyde to be processed per batch (based on 500 g of CO<sub>2</sub>).

## CONCLUSIONS

The zinc-mediated Barbier allylation represents an example of an important synthetic reaction, which we show in the present study, can be performed in subcritical CO<sub>2</sub> in the presence of a polar medium, specifically an aqueous phase. The inability of the reaction to progress effectively in only CO<sub>2</sub> justifies the use of a CO<sub>2</sub>/H<sub>2</sub>O biphasic mixture. The CO<sub>2</sub> phase offers an environment for solubilizing the hydrophobic (organic) reagents and critically also allows preferential partitioning of the homoallylic alcohol product, facilitating its recovery from the aqueous phase. Separation of the mixture following the reaction was straightforward and afforded moderate isolated yields of solvent-free allylation product in relatively short reaction times. The replacement of organic solvents by CO<sub>2</sub> thus allowed clean synthesis while avoiding further energy-intensive work-up stages. Cheap commercially available zinc dust proved to be an efficient and safe promoter for the reaction. A range of mediators and conditions were explored in order to assess the effects on yields and chemoselectivity. Experiments using Tween 80 (a biocompatible surfactant able to stabilize emulsions with higher interfacial areas), saturated salt solutions as the aqueous phase, and higher temperatures suggest that the improved yields and chemoselectivities for the homoallylic alcohol product were the result of rate enhancements over the competing zinc-mediated reduction. In terms of mixing capacity, pulsed ultrasound provided an efficient mechanism for dispersing and mixing of the phases, while ensuring operation in the kinetically-controlled regime.

## ASSOCIATED CONTENT

### Supporting Information

GC settings and retention times and NMR spectral data. This material is available free of charge via the Internet at <http://pubs.acs.org>.

## AUTHOR INFORMATION

### Corresponding Author

\*E-mail: [g.a.leeke@bham.ac.uk](mailto:g.a.leeke@bham.ac.uk).

### Notes

The authors declare no competing financial interest.

## ACKNOWLEDGMENTS

We thank the Engineering and Physical Sciences Research Council for a studentship to S.M.C. The NMR spectrometers used in this research were funded in part through Birmingham Science City: Innovative Uses for Advanced Materials in the Modern World (West Midlands Centre for Advanced Materials Project 2) with support from Advantage West Midlands and part funded by the European Regional Development Fund.

## REFERENCES

- (1) Tucker, J. L. Green chemistry, a pharmaceutical perspective. *Org. Process Res. Dev.* **2006**, *10* (2), 315–319.
- (2) Cenci, S. M.; Cox, L. R.; Leeke, G. A. Recent advances in catalysis for efficient process chemistry. *Recent Pat. Catal.* **2012**, *1* (1), 2–12.
- (3) Burgemeister, K.; Franciò, G.; Gego, V. H.; Greiner, L.; Hugl, H.; Leitner, W. Inverted supercritical carbon dioxide/aqueous biphasic media for rhodium-catalyzed hydrogenation reactions. *Chem.—Eur. J.* **2007**, *13* (10), 2798–2804.
- (4) Bourne, R. A.; Stevens, J. G.; Ke, J.; Poliakoff, M. Maximising opportunities in supercritical chemistry: The continuous conversion of levulinic acid to  $\gamma$ -valerolactone in CO<sub>2</sub>. *Chem. Commun.* **2007**, No. 44, 4632–4634.
- (5) Leeke, G.; Santos, R.; Al-Duri, B.; Seville, J.; Smith, C.; Holmes, A. B. Solubilities of 4-phenyltoluene, phenylboric acid, biphenyl, and iodobenzene in carbon dioxide from measurements of the relative permittivity. *J. Chem. Eng. Data* **2005**, *50* (4), 1370–1374.
- (6) Lee, J.-K.; Fuchter, M. J.; Williamson, R. M.; Leeke, G. A.; Bush, E. J.; McConvey, I. F.; Saubern, S.; Ryan, J. H.; Holmes, A. B. Diaryl ether synthesis in supercritical carbon dioxide in batch and continuous flow modes. *Chem. Commun.* **2008**, No. 39, 4780.
- (7) King, M. B.; Mubarak, A.; Kim, J. D.; Bott, T. R. The mutual solubilities of water with supercritical and liquid carbon dioxide. *J. Supercrit. Fluid.* **1992**, *5* (4), 296–302.
- (8) Chen, D.; Sharma, S. K.; Mudhoo, A., Eds.; *Handbook on Applications of Ultrasound: Sonochemistry for Sustainability*; CRC Press: Boca Raton, FL, 2012.
- (9) Oakes, R. S.; Heppenstall, T. J.; Shezad, N.; Clifford, A. A.; Rayner, C. M. Use of scandium tris(trifluoromethanesulfonate) as a Lewis acid catalyst in supercritical carbon dioxide: Efficient Diels-Alder reactions and pressure dependent enhancement of endo:exo stereoselectivity. *Chem. Commun.* **1999**, No. 16, 1459–1460.
- (10) Oakes, R. S.; Clifford, A. A.; Rayner, C. M. The use of supercritical fluids in synthetic organic chemistry. *J. Chem. Soc., Perkin Trans. 1* **2001**, No. 9, 917–941.
- (11) Shezad, N.; Clifford, A. A.; Rayner, C. M. Pd-catalysed coupling reactions in supercritical carbon dioxide and under solventless conditions. *Green Chem.* **2002**, *4* (1), 64–67.
- (12) Kainz, S.; Brinkmann, A.; Leitner, W.; Pfaltz, A. Iridium-catalyzed enantioselective hydrogenation of imines in supercritical carbon dioxide. *J. Am. Chem. Soc.* **1999**, *121* (27), 6421–6429.
- (13) Bhanage, B. M.; Ikushima, Y.; Shirai, M.; Arai, M. Heck reactions using water-soluble metal complexes in supercritical carbon dioxide. *Tetrahedron Lett.* **1999**, *40* (35), 6427–6430.
- (14) Bhanage, B. M.; Ikushima, Y.; Shirai, M.; Arai, M. Multiphase catalysis using water-soluble metal complexes in supercritical carbon dioxide. *Chem. Commun.* **1999**, No. 14, 1277–1278.
- (15) Holmes, J. D.; Ziegler, K. J.; Audriani, M.; Lee, C. T.; Bhargava, P. A.; Steytler, D. C.; Johnston, K. P. Buffering the aqueous phase pH in water-in-CO<sub>2</sub> microemulsions. *J. Phys. Chem., B* **1999**, *103* (27), 5703–5711.

- (16) Cenci, S. M.; Cox, L. R.; Leeke, G. A. Ultrasound-induced emulsification of subcritical carbon dioxide/water with and without surfactant as a strategy for enhanced mass transport. *Ultrason. Sonochem.* **2014**, *21* (1), 401–408.
- (17) Li, C. J. Aqueous Barbier–Grignard type reaction: Scope, mechanism, and synthetic applications. *Tetrahedron* **1996**, *52* (16), 5643–5668.
- (18) Gordon, C. M.; Ritchie, C. Indium and tin-mediated allylation in ionic liquids. *Green Chem.* **2002**, *4* (2), 124–128.
- (19) Kopach, M. E.; Roberts, D. J.; Johnson, M. D.; Groh, J. M.; Adler, J. J.; Schafer, J. P.; Kobierski, M. E.; Trankle, W. G. The continuous flow Barbier reaction: A improved environmental alternative to the Grignard reaction? *Green Chem.* **2012**, *14* (5), 1524–1536.
- (20) Andrews, P. C.; Peatt, A. C.; Raston, C. L. Metal mediated solvent free synthesis of homoallylic alcohols. *Green Chem.* **2001**, *3* (6), 313–315.
- (21) Haberman, J. X.; Irvin, G. C.; John, V. T.; Li, C. J. Aldehyde allylation in liquid carbon dioxide. *Green Chem.* **1999**, *1* (6), 265–267.
- (22) Ranu, B. C.; Majee, A.; Das, A. R. Facile and efficient synthesis of homoallylic alcohols using allyl bromide and commercial zinc dust. *Tetrahedron Lett.* **1995**, *36* (27), 4885–4888.
- (23) Petrier, C.; Luche, J. L. Allylzinc reagent additions in aqueous-media. *J. Org. Chem.* **1985**, *50* (6), 910–912.
- (24) Henglein, A.; Gutierrez, M. Sonolysis of polymers in aqueous-solution – New observations on Pyrolysis and Mechanical Degradation. *J. Phys. Chem.* **1988**, *92* (13), 3705–3707.
- (25) Li, C. J.; Zhang, W. C. Unexpected Barbier–Grignard allylation of aldehydes with magnesium in water. *J. Am. Chem. Soc.* **1998**, *120* (35), 9102–9103.
- (26) Liu, S.; Wang, Y.; Jiang, J.; Jin, Z. The selective reduction of nitroarenes to *N*-arylhydroxylamines using Zn in a CO<sub>2</sub>/H<sub>2</sub>O system. *Green Chem.* **2009**, *11* (9), 1397–1400.
- (27) Timko, M. T.; Nicholson, B. F.; Steinfeld, J. I.; Smith, K. A.; Tester, J. W. Partition coefficients of organic solutes between supercritical carbon dioxide and water: Experimental measurements and empirical correlations. *J. Chem. Eng. Data* **2004**, *49* (4), 768–778.
- (28) Lu, G.-P.; Cai, C.; Lipshutz, B. H. Stille couplings in water at room temperature. *Green Chem.* **2013**, *15* (1), 105–109.
- (29) Manabe, K.; Mori, Y.; Wakabayashi, T.; Nagayama, S.; Kobayashi, S. Organic synthesis inside particles in water: Lewis acid-surfactant-combined catalysts for organic reactions in water using colloidal dispersions as reaction media. *J. Am. Chem. Soc.* **2000**, *122* (30), 7202–7207.
- (30) Timko, M. T.; Smith, K. A.; Danheiser, R. L.; Steinfeld, J. I.; Tester, J. W. Reaction rates in ultrasonic emulsions of dense carbon dioxide and water. *AIChE J.* **2006**, *52* (3), 1127–1141.
- (31) Lee, C. T.; Psathas, P. A.; Johnston, K. P.; deGrazia, J.; Randolph, T. W. Water-in-carbon dioxide emulsions: formation and stability. *Langmuir* **1999**, *15* (20), 6781–6791.
- (32) O Shea, K. E.; Kirmse, K. M.; Fox, M. A.; Johnston, K. P. Polar and hydrogen-bonding interactions in supercritical fluids – Effects on the tautomeric equilibrium of 4-(phenylazo)-1-naphthol. *J. Phys. Chem.* **1991**, *95* (20), 7863–7867.
- (33) Jacobson, G. B.; Lee, C. T.; da Rocha, R. P.; Johnston, K. P. Organic synthesis in water carbon dioxide emulsions. *J. Org. Chem.* **1999**, *64* (4), 1207–1210.
- (34) Hoefling, T. A.; Enick, R. M.; Beckman, E. J. Microemulsions in near-critical and supercritical CO<sub>2</sub>. *J. Phys. Chem.* **1991**, *95* (19), 7127–7129.
- (35) Jacobson, G. B.; Lee, C. T.; Johnston, K. P.; Tumas, W. Enhanced catalyst reactivity and separations using water/carbon dioxide emulsions. *J. Am. Chem. Soc.* **1999**, *121* (50), 11902–11903.
- (36) Torino, E.; Reverchon, E.; Johnston, K. P. Carbon dioxide/water, water/carbon dioxide emulsions and double emulsions stabilized with a nonionic biocompatible surfactant. *J. Colloid Interface Sci.* **2010**, *348* (2), 469–478.
- (37) Poteshnova, M. V.; Zadymova, N. M. Normal micelles and oil-in-water microemulsions in a water-toluene-Tween 80 ternary system. *Colloid J.* **2006**, *68* (2), 201–210.
- (38) Thoman, C. J. The versatility of Polysorbate 80 (Tween 80) as an ionophore. *J. Pharm. Sci.* **1999**, *88* (2), 258–260.
- (39) Thoman, C. J.; Habeeb, T. D.; Huhn, M.; Korpusik, M.; Slish, D. F. Use of Polysorbate-80 (Tween 80) as a phase-transfer catalyst. *J. Org. Chem.* **1989**, *54* (18), 4476–4478.
- (40) Kapdi, A. R.; Jain, C.; Padte, T.; Shevde, U.; Pednekar, S.; Fischer, C.; Schulzke, C. Tween-80: A bio-degradable and recyclable phase transfer catalyst for microwave assisted synthesis of highly substituted dicoumarols. *Int. J. Green Chem. Bioprocess* **2013**, *3*, 17–23.
- (41) Van Santen, R. A.; Van Leeuwen, P. W. N. M.; Moulijn, J. A.; Averill, B. A. Catalytic reaction engineering. In *Catalysis: An Integrated Approach*; Elsevier Science: Amsterdam, 1999.
- (42) Levenspiel, O. Fluid–Fluid Reactions: Kinetics. In *Chemical Reaction Engineering*; John Wiley & Sons: New York, 1999.
- (43) Denmark, S. E.; Fu, J. P. On the mechanism of catalytic, enantioselective allylation of aldehydes with chlorosilanes and chiral Lewis bases. *J. Am. Chem. Soc.* **2000**, *122* (48), 12021–12022.
- (44) Kalkan, M.; Erdik, E. Reactivities of mixed organozinc and mixed organocopper reagents. Part 7. Comparison of the transfer rate of the same group in allylation of mixed and homo diorganozinc reagents. *J. Phys. Org. Chem.* **2013**, *26* (3), 256–260.
- (45) Hodgson, D. M.; Talbot, E. P. A.; Clark, B. P. Stereoselective synthesis of beta-(hydroxymethylaryl/alkyl)-alpha-methylene-gamma-butyrolactones. *Org. Lett.* **2011**, *13* (10), 2594–2597.
- (46) Gao, Y.; Wang, X.; Sun, L.; Xie, L.; Xu, X. Zinc or indium-mediated Barbier-type allylation of aldehydes with 3-bromomethyl-5H-furan-2-one in aqueous media: an efficient synthesis method for  $\alpha$ -methylene- $\gamma$ -butyrolactone. *Org. Biomol. Chem.* **2012**, *10* (20), 3991–3998.
- (47) Sun, X.-W.; Liu, M.; Xu, M.-H.; Lin, G.-Q. Remarkable salt effect on In-mediated allylation of *N*-tert-butanesulfinyl imines in aqueous media: Highly practical asymmetric synthesis of chiral homoallylic amines and isoindolinones. *Org. Lett.* **2008**, *10* (6), 1259–1262.
- (48) Van Gheem, E.; Vereecken, J.; Le Pen, C. Influence of different anions on the behaviour of aluminium in aqueous solutions. *J. Appl. Electrochem.* **2002**, *32* (11), 1193–1200.
- (49) Dam, J. H.; Fristrup, P.; Madsen, R. Combined experimental and theoretical mechanistic investigation of the Barbier allylation in aqueous media. *J. Org. Chem.* **2008**, *73* (8), 3228–3235.
- (50) Wagner, K.-D.; Dahmen, N.; Griesheimer, P. Salt effects on the partition coefficients of phenol in two-phase mixtures of water and carbon dioxide at pressures from 8 to 30 MPa at a temperature of 313 K. *J. Chem. Thermodyn.* **2003**, *35* (4), 677–687.
- (51) Sieder, G.; Maurer, G. Experimental investigation of the influence of the single salts sodium chloride and sodium acetate on the high-pressure phase equilibrium of the system carbon dioxide plus water plus acetic acid. *J. Chem. Eng. Data* **2004**, *49* (5), 1303–1310.
- (52) Roy, U. K.; Roy, S. Making and breaking of Sn-C and In-C bonds in situ: The cases of allyltins and allylindiums. *Chem. Rev.* **2010**, *110* (4), 2472–2535.
- (53) Guimaraes, R. L.; Lima, D. J. P.; Barros, M. E. S. B.; Cavalcanti, L. N.; Hallwass, F.; Navarro, M.; Bieber, L. W.; Malvestiti, I. Aqueous Barbier allylation of aldehydes mediated by tin. *Molecules* **2007**, *12* (9), 2089–2105.
- (54) Petrier, C.; Einhorn, J.; Luche, J. L. Selective tin and zinc mediated allylations of carbonyl compounds in aqueous media. *Tetrahedron Lett.* **1985**, *26* (11), 1449–1452.
- (55) Einhorn, C.; Luche, J. L. Selective allylation of carbonyl compounds in aqueous media. *J. Organomet. Chem.* **1987**, *322* (2), 177–183.
- (56) Wang, Z. Y.; Zha, Z. G.; Zhou, C. L. Application of tin and nanometer tin in allylation of carbonyl compounds in tap water. *Org. Lett.* **2002**, *4* (10), 1683–1685.



(57) Zha, Z. G.; Qiao, S.; Jiang, J. Y.; Wang, Y. S.; Miao, Q.; Wang, Z. Y. Barbier-type reaction mediated with tin nano-particles in water. *Tetrahedron* **2005**, *61* (9), 2521–2527.

(58) Zha, Z. G.; Xie, Z.; Zhou, C. L.; Chang, M. X.; Wang, Z. Y. High regio- and stereoselective Barbier reaction of carbonyl compounds mediated by  $\text{NaBF}_4/\text{Zn}$  (Sn) in water. *New J. Chem.* **2003**, *27* (9), 1297–1300.

(59) Houlemare, D.; Outurquin, F.; Paulmier, C. Synthesis of homoallylic (but-3-enylic) alcohols from aldehydes with allylic chlorides, tin(II) chloride and potassium iodide in water. *J. Chem. Soc., Perkin Trans. 1* **1997**, No. 11, 1629–1632.

(60) Carey, J. S.; Laffan, D.; Thomson, C.; Williams, M. T. Analysis of the reactions used for the preparation of drug candidate molecules. *Org. Biomol. Chem.* **2006**, *4* (12), 2337.

(61) Blanchard, L. A.; Brennecke, J. F. Recovery of organic products from ionic liquids using supercritical carbon dioxide. *Ind. Eng. Chem. Res.* **2001**, *40* (1), 287–292.

(62) Walther, D.; Maurer, G. High-pressure vapor-liquid-equilibria in binary-mixtures of carbon-dioxide and benzaldehyde, bromobenzene, chlorobenzene, 1,2-dichlorobenzene and 2-chloro-1-methylbenzene at temperatures between 313 and 393 K and pressures up to 22 MPa. *Ber. Bunsen Phys. Chem.* **1992**, *96* (8), 981–988.