



ORIGINAL ARTICLE

Life cycle evaluation of an intercooled gas turbine plant used in conjunction with renewable energy



Thank-God Isaiah*, Siddig Dabbashi, Dawid Bosak, Suresh Sampath, Giuseppina Di Lorenzo, Pericles Pilidis

Department of Power and Propulsion, School of Engineering, Cranfield University, Cranfield, Bedfordshire MK43 0AL, United Kingdom

Received 21 August 2015; accepted 5 April 2016

Available online 12 August 2016

KEYWORDS

Gas turbines;
Life cycle;
Load-Following;
Power demand;
Renewable energy;
Thermodynamic cycle;
Thermal efficiency

Abstract The life cycle estimation of power plants is important for gas turbine operators. With the introduction of wind energy into the grid, gas turbine operators now operate their plants in Load-Following modes as back-ups to the renewable energy sources which include wind, solar, etc. The motive behind this study is to look at how much life is consumed when an intercooled power plant with 100 MW power output is used in conjunction with wind energy. This operation causes fluctuations because the wind energy is unpredictable and overtime causes adverse effects on the life of the plant – The High Pressure Turbine Blades. Such fluctuations give rise to low cycle fatigue and creep failure of the blades depending on the operating regime used. A performance based model that is capable of estimating the life consumed of an intercooled power plant has been developed. The model has the capability of estimating the life consumed based on seasonal power demands and operations. An in-depth comparison was undertaken on the life consumed during the seasons of operation and arrives at the conclusion that during summer, the creep and low cycle life is consumed higher than the rest periods. A comparison was also made to determine the life consumed between Load-Following and stop/start operating scenarios. It was also observed that daily creep life consumption in summer was higher than the winter period in spite of having lower average daily operating hours in a Start-Stop operating scenario.

© 2016 National Laboratory for Aeronautics and Astronautics. Production and hosting by Elsevier B.V.

This is an open access article under the CC BY-NC-ND license (<http://creativecommons.org/licenses/by-nc-nd/4.0/>).

*Corresponding author. Tel.: 07901321090.

E-mail address: t.isaiah@cranfield.ac.uk (Thank-God Isaiah).

Peer review under responsibility of National Laboratory for Aeronautics and Astronautics, China.

1. Introduction

There is an increasing interest in operating intermittent Renewable Energy Sources such as wind power and solar energy generation with conventional utility plants [1]. This has been as a result of the unprecedented demands for operational plant flexibility and meeting with the UK Government targets for an 80% reduction in CO₂ emissions by 2050 and beyond [2]. In achieving this, the power sector will have a major role to play. Despite the achievements achieved so far, there'll be a vital role for flexible operation of power plants. A possible way of increasing the plant's flexibility and also in conjunction with renewable energy sources (RES) – wind, is by operating the plant in a load following mode especially during low demand periods of electricity. By operating in this mode, it is beneficial to the plant operator economically, because it saves costs for start-ups and shut-downs and can meet up with the demands of the grid by supplying power quickly when required. That notwithstanding, Load-Following operations has its own consequences. Load-Following operations cause fluctuations over time during operation especially when seasonal scenarios are considered due to different ambient conditions it has to operate under [3]. The transition to load following operations (LFO) causes temperature differences in the rotor and thick-walled components in the hot gas section and results in the production of thermal stresses and deteriorations which can decrease the life of the turbine blades or at worse destroy the turbine [4]. Fatigue and creep due to these thermal stresses during cycling operations constitute to a great extent the underlying problems with almost all power plants. The HPT blades of the hot gas section of gas turbines has always been the life limiting component due to the high level of rotational speeds and turbine entry temperatures it operates on [5]. Also, the GTs will have to cope with the flexibility requirements mainly due to the 'Start-Stop' operations based on the highly fluctuating availability of 'RES' – wind energy (as considered in this study). As part of research, a tool has been developed. This tool has the capability of giving an

estimate of how much life is being consumed for Load-Following plants used during seasonal operations.

2. Methodology

An algorithm was developed in 'FORTRAN 90/95' as shown below in the lifing methodology (Figure 1). The lifing model estimates the life – both creep and low cycle fatigue of the intercooled gas turbine power plant with 100 MW capacity. The lifing model comprises of the following modules: Performance simulation module, Stress analysis module, thermal module; material properties module, LCF life module and creep life module. This gives the period between overhaul which in turn is used to estimate the maintenance cost of the gas turbine plant.

2.1. Performance module

Gas turbine performance is characterised by three basic components namely - the mass flow, the firing temperature also known as TET and the pressure ratio [6]. The performance simulation and engine model was carried out using Turbomatch which is a component based gas turbine tool developed at Cranfield University [4]. Performance module initiative as shown in Figure 2. Turbomatch models an engine performance at both design and a range of possible off-design conditions that is usually experienced based on the ambient conditions (Seasons) [7].

For each season considered, input files were constructed based on ambient conditions to obtain the DP and ODP performance for each of the gas turbine plants been used as case studies. The first case study looks at how seasonal changes affect the life of the plant especially when the plant is being integrated to run with wind energy, so the variables considered in this study are:

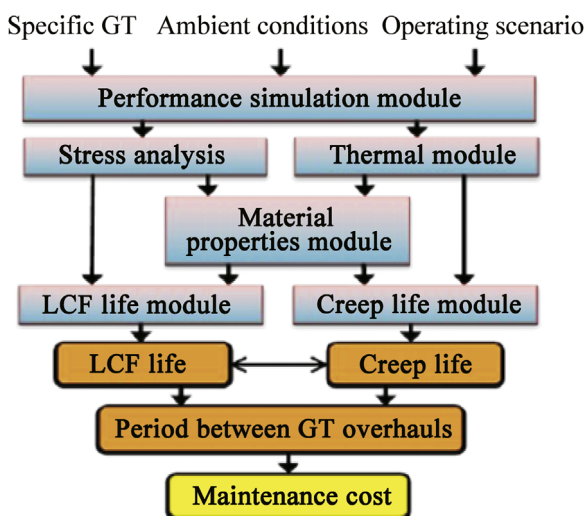

Figure 1 Lifing model methodology.

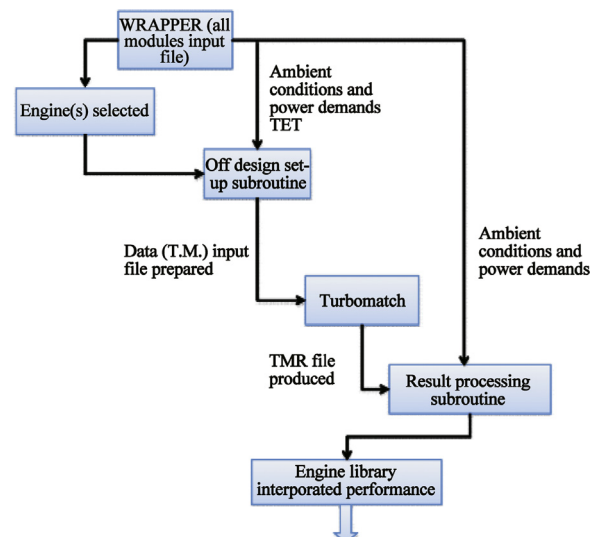

Figure 2 Performance module initiative.

Table 1 Engine performance data.

Parameters	Units	Value
Power output	MW	100
TET	K	1630
Efficiency	%	44
RPM	rev/min	9300
Fuel flow	kg/s	5.27
Mass flow	kg/s	216
Pressure ratio		42

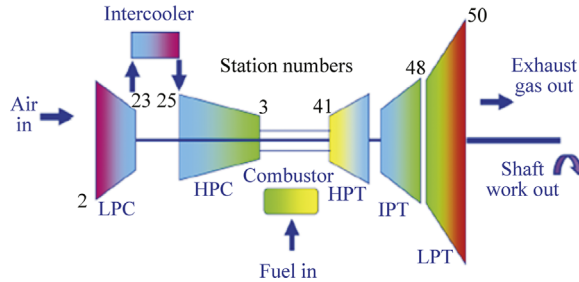

Figure 3 Engine configuration.

- Ambient temperatures.
- Turbine entry temperatures.

It was assumed that the ambient pressure is constant for simplicity. Turbomatch calculates the ODP results for each value of the specified ambient temperature and TET. The input values were integrated in FORTRAN file as shown below (Table 1). The engine configuration as shown Figure 3. The performance module extracts the engine data that is relevant in the case study considered from a database library of the engine input that is created by the author. As the ambient temperature changes; the power output, fuel flow, TET, and PCN also change [8]. The performance results obtained have been compared with performance results using ‘Gas Turb’ performance software – which is a gas turbine packet commercial programme used for estimating both design and of-design performance of power plants.

Similar studies using “Turbomatch” performance tool from Journal of Propulsion and Power Research can be found in Ref. [17].

2.2. Stress module

The gas turbine blades usually undergo high stresses which are credited to thermal stresses, gas bending moments, centrifugal loads, etc. From all the stresses, the most prevalent are that of the centrifugal and thermal stresses because the gas bending moments are usually counterbalanced by measures such as blade leaning [9]. The aim of this model is to estimate the maximum stresses at all the locations of the blade span. The blade has been divided into two sections which is from mid to root section and mid to tip section in order to eliminate the complications in terms of inputs to be used in the model (Figure 4).

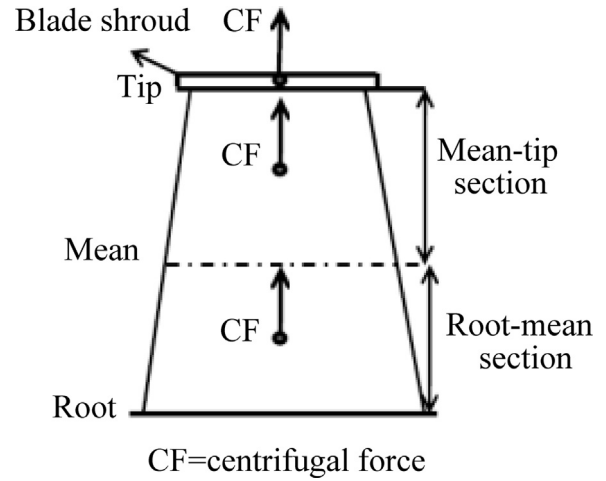

Figure 4 Blade profile.

The stress model defines the stresses on the turbine blade resulting from the operating conditions. Due to the mass of the blade, the model only considers the centrifugal stresses that arise during operation. Some assumptions were made in this model; the centrifugal force acts at a blade section centre of gravity and the axial velocity along the span of the blade remains constant throughout. Full details of the stress model can be found in Ref. [8]. Figure 5 below shows a sketch of a blade in 3-D.

2.3. Materials properties module

The material properties module defines the properties according to material temperature and the applied stress. LMP for creep life calculations is defined according to the applied stress whereas other mechanical properties for LCF are defined according to material temperature. In this module, material properties graphs and tables has been converted into equations to define each property at any temperature, and to define LMP at any applied stress.

2.4. Creep life module

The function of this module is to estimate creep life (time to rupture) and creep life consumption. Input data is received from the thermal module as hourly material operating temperatures and from the material properties module as hourly LMP values. Estimation of creep life in the creep life module is carried out by Larson–Miller method. Full details can be found in Ref. [8].

$$LMP = \frac{T_M}{1000} (\log t_f + C) \tag{1}$$

Creep life in hours:

$$\left(t_f = 10 \left(\frac{1000LMP}{T} - C \right) \right) \tag{2}$$

The creep life consumption per hour = $1/t_f$.

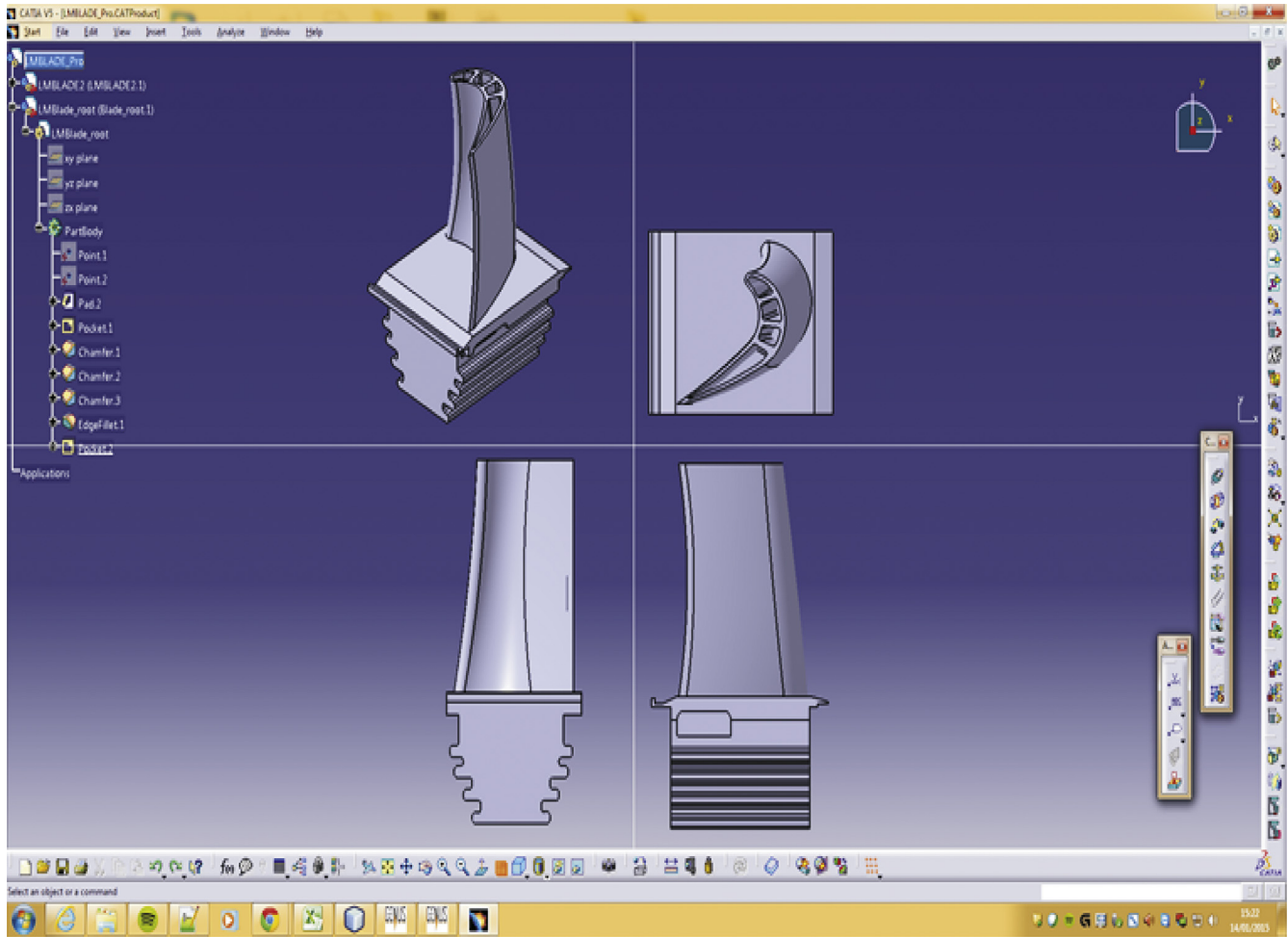

Figure 5 A 3-D blade model showing the pressure and suction side [10,11].

where

- t_f =time to failure (hours);
- T =absolute operating temperature (K);
- C =Larson–Miller constant.

2.5. Low cycle fatigue module

This model estimates the number of cycles to failure using the Coffin–Manson approach and Neuber's constant for stress concentration using the below stated equations:

σ_a =stress concentration factor \times maximum stress on the blade

$$\epsilon_a = \frac{\sigma_a}{E} \tag{3}$$

Neuber's constant = $\sigma \times \epsilon$.

$$\epsilon = \frac{\sigma}{E} + \left(\frac{\sigma}{K'}\right)^{\frac{1}{n'}} \tag{4}$$

$$K' = \frac{\sigma'f}{(\epsilon f)^{n'}} \tag{5}$$

$$n' = \frac{b}{c} \tag{6}$$

where

- σ_a =applied stress at stress concentration zone;
- ϵ_a =strain resulted at stress concentration zone;
- E =modulus of elasticity;
- σ =cyclic maximum stress;
- ϵ =cyclic maximum strain;
- K' =cyclic strength coefficient;
- $\sigma'f$ =fatigue strength coefficient;
- ϵ_f =fatigue ductility coefficient;
- n' =cyclic strain hardening exponent;
- b =fatigue strength exponent;
- c =fatigue ductility exponent.

By solving Eqs. (5) and (6), σ and ϵ values can be defined. The behaviour for cyclic unloading becomes:

$$\text{Neuber's constant} = \Delta\sigma \times \Delta\epsilon$$

$$\Delta\epsilon = \frac{\Delta\sigma}{E} + 2 \left(\frac{\sigma}{2K'} \right)^{\frac{1}{n}} \quad (7)$$

where

- N_f = number of cycles to failure;
- E = elasticity modulus;
- σ_f = material strength;

b and c are constants which is equivalent to -0.12 and -0.6 for majority of materials [12].

By solving Eq. (8), N_f can be defined.

$$\text{Daily LCF consumption} = \frac{\text{number of cycles per day}}{N_f} \quad (8)$$

Using the developed models as explained above, a program was written in FORTRAN 90 language which provides an improvement in both academic and industrial perspective for GT power plant performance. When power plants are used in conjunction with wind energy, this model has the capability to estimate the life for both daily and seasonal operations. Results obtained are used to develop performance trade-off maps which aids power plant operators in making better techno-economic decisions.

3. Results and discussion

Seasonal operating scenarios (Figures 6–9) for 100 MW gas turbine have been created according to the data had been collected from the UK National Grid Status website (<http://www.gridwatch.templar.co.uk/>) [12]. These scenarios are based on 2014 daily data for each scenario. It is obvious that the highest demand of electricity from Combined Cycle Gas Turbine (CCGT) plants occurs in winter and summer due to heating requirements for the first and the shortage of wind energy production for the latter.

Furthermore, summer demand is stable during the day time (full capacity), whereas the demand increases in the evening in spring, autumn and winter because of house lighting and heating. The maximum variation in power capacity between the night and day time is noticeable in winter.

Seasonal daily ambient temperatures scenarios data have been collected from Weather Underground website ([http://](http://www.wunderground.com/)

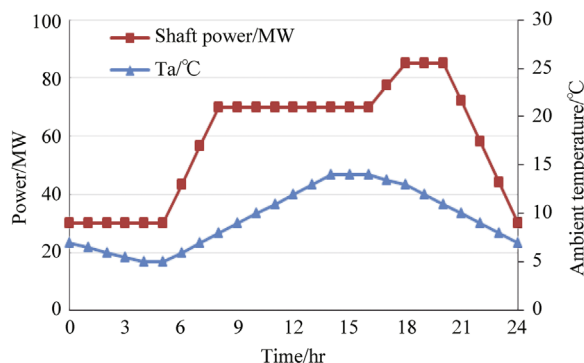

Figure 6 Spring daily operating scenario and ambient temperatures.

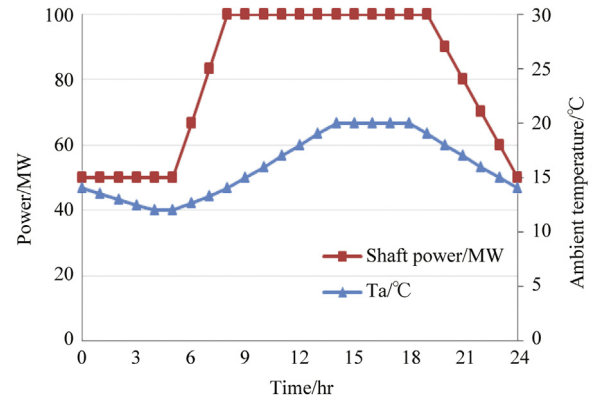

Figure 7 Summer daily operating scenario and ambient temperatures.

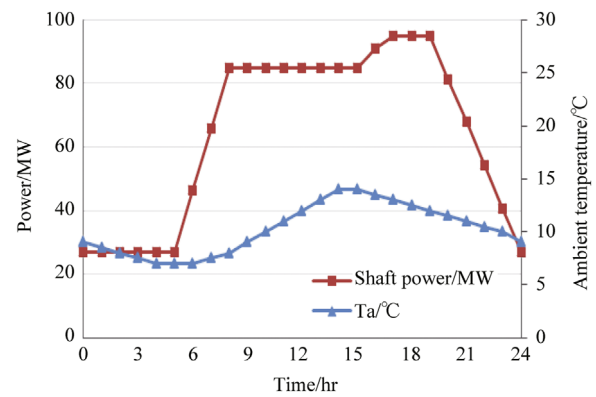

Figure 8 Autumn daily operating scenario and ambient temperatures.

www.wunderground.com/) [13] for Birmingham as an average of the UK weather.

3.1. Performance simulation results

Performance simulation has been carried out using In-House software TURBOMATCH [14–16] in order to define the main factors affecting creep life and low cycle fatigue (LCF) life. Figure 10 represents daily hour-by-hour turbine entry temperatures TET, cooling air temperatures Tc, and rotational speeds PCN for the four seasons.

Summer day has the highest values of TET, Tc and PCN due to the high power capacity and high ambient temperatures, which could be reflected in obvious effect on creep life and LCF life. Although power capacity in winter is higher, autumn day values of TET, Tc and PCN are higher because of the higher ambient temperatures, whereas spring values are the lowest because of the low power capacity. These values affect significantly creep life and slightly LCF life. LCF life is significantly affected by the variation in PCN and slightly by TET and Tc variation.

The maximum variation in TET, Tc and PCN occurs in winter, which has the highest daily power setting variation. In addition, summer has the minimum values of variation regarding the low variation in power setting during the summer day.

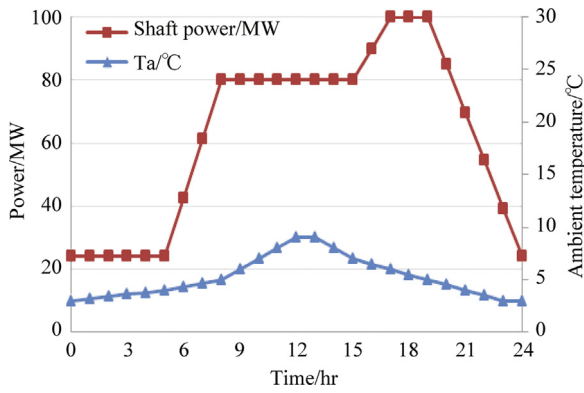

Figure 9 Winter daily operating scenario and ambient temperatures.

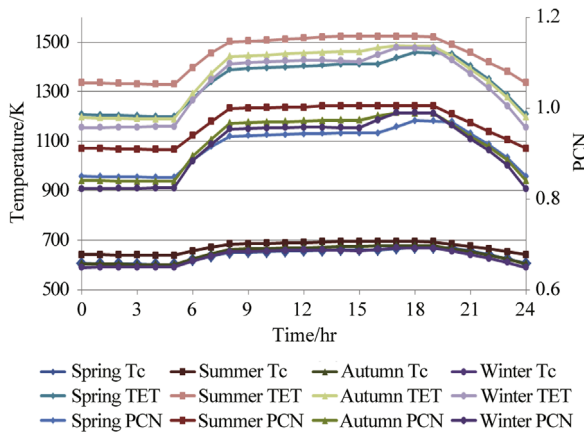

Figure 10 Seasonal performance simulation results (TET, Tc and PCN).

3.2. Start-Stop scenarios

In order to investigate the effect of operating method on gas turbine performance and life, Start-Stop scenarios for summer and winter has been created. These scenarios are used for a fleet of gas turbines in a power plant to produce the same power profile according to the seasonal scenarios.

3.2.1. Summer

Figure 11 illustrates 2 × 100 MW gas turbine power plant Start-Stop operating scenario. Total power produced by this scenario varies between 100 MW at night and 200 MW at day peak, which represents 50% of power plant capacity at night and 100% at day peak (Figure 12).

Figure 13 illustrates performance simulation results for the first gas turbine according to summer Start-Stop scenario, and Figure 14 shows performance simulation results for the second gas turbine. Maximum values of TET and PCN appear at mid-day where the power production and ambient temperature are in their highest values. Although they have the same power setting, the night has smaller values of TET and PCN than day time due to the reduction in ambient temperature. This case is for the first

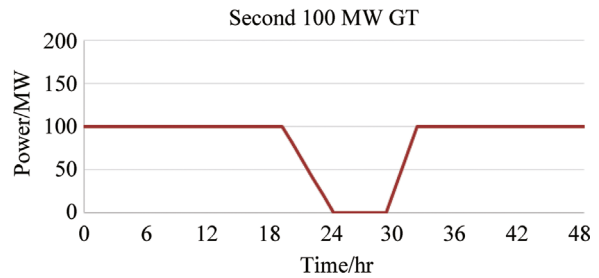
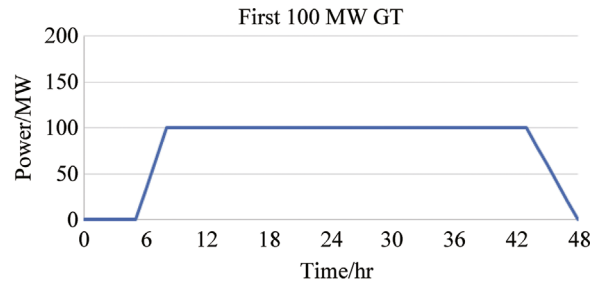

Figure 11 2 × 100 MW gas turbine power plant Start-Stop operating scenario (summer).

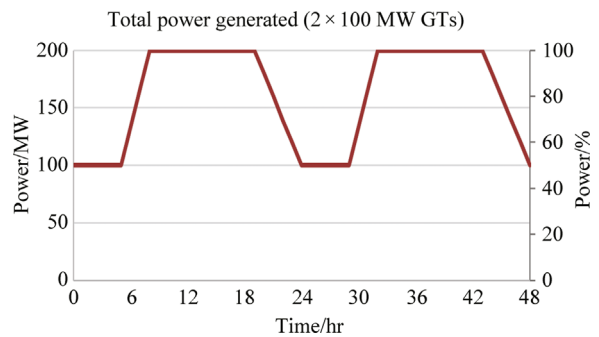

Figure 12 Total power produced by 2 × 100 MW gas turbine (summer).

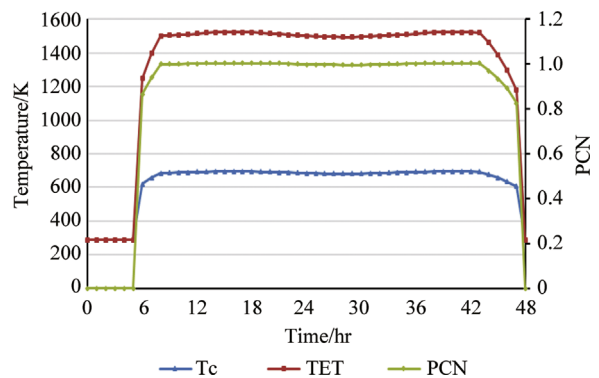

Figure 13 First gas turbine performance simulation results during 2 days (summer).

gas turbine at second night and for the second gas turbine at the first night, where the engine is not switched off at night.

3.2.2. Winter

The same summer Start-Stop concept is used for the winter. Regarding the variation in power demand between

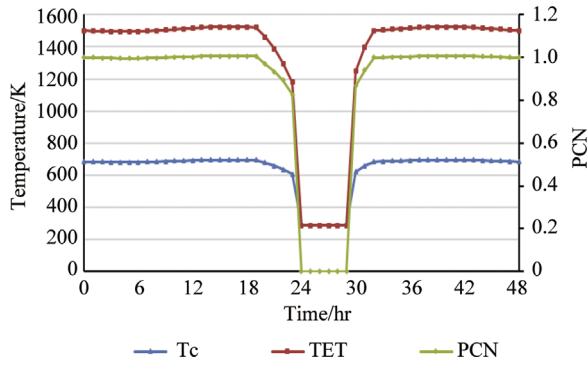

Figure 14 Second gas turbine performance simulation results during 2 days (summer).

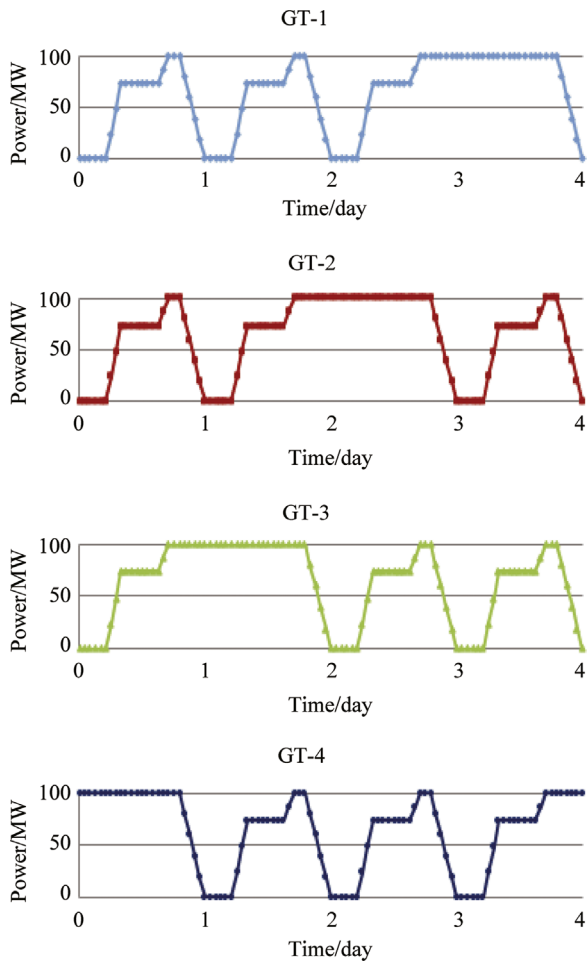

Figure 15 Gas turbine 1, gas turbine 2, gas turbine 3 and gas turbine 4: Start-Stop operating scenario during 4 days (winter).

night (25%) and day peak (100%), a power plant of a fleet of four 100 MW gas turbines has been selected. During a period of four days, every gas turbine will be kept ON night and the other three will be switched off (Figure 15). The result of total power produced by the four gas turbines during four days is shown in Figure 16, which matches winter daily power demand in percentage that varies between 25% at night and 100% at day peak.

Figure 17 illustrates TET, Tc and PCN values during four days operation for (gas turbine 1) based on the results from performance simulation. It shows the variation in TET between their maximum temperature values and ambient temperature values. Also, it shows the variation in PCN between their maximum value and zero value, which will be reflected in LCF life and creep life estimation.

3.2.3. Load-Following scenarios: creep life for four seasons

The results show the variation in creep life (Figure 18) for different seasons and Base-Load operating scenarios. Values of the shaft rotational speed resulted in certain values of centrifugal stress on high pressure turbine blade. According to this value, Larson-Miller parameter (LMP)

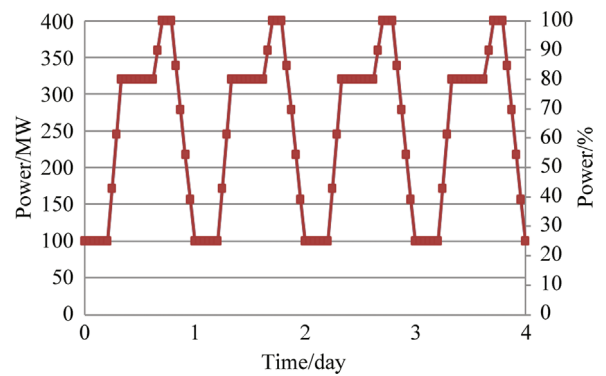

Figure 16 Total power produced during 4 days (winter).

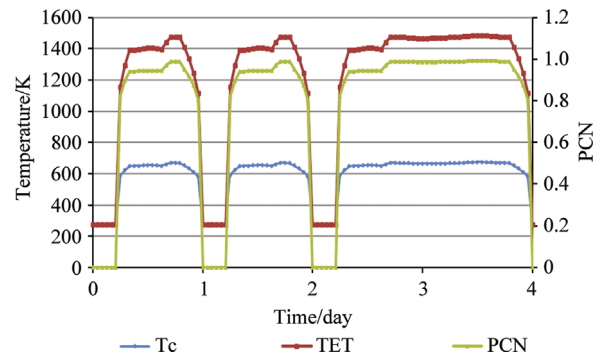

Figure 17 TET, Tc and PCN for GT-1 Start-Stop scenario (winter).

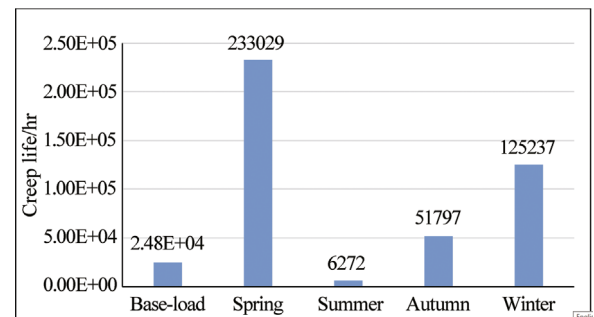

Figure 18 Creep life in 4 seasons for reference engine.

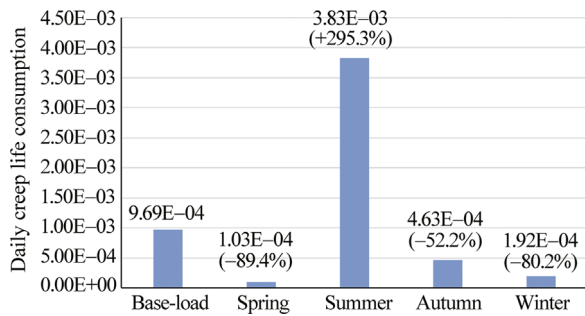

Figure 19 Daily creep life consumption for reference engine.

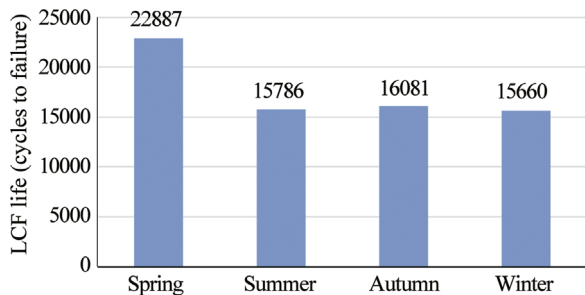

Figure 20 LCF Life for reference engine.

will be defined. LMP combined with blade operating temperature resulted in the value of creep life.

Summer operating scenario has the highest creep life consumption (Figure 19), which resulted in the lowest creep life (Figure 18). This is because the high values of TET, Tc and PCN resulted from high power setting and high ambient temperatures. The lowest creep life consumption occurs in spring due to low power settings and low ambient temperatures.

In spite of having lower ambient temperatures, creep life consumption in winter is higher than it in spring due to higher power setting. Although spring and autumn have similar ambient conditions, spring has significantly greater creep life resulted from smaller values of TET, Tc and PCN regarding the lower power setting.

3.2.4. Load-Following scenario – low cycle fatigue for four seasons

The effect of both daily power setting variation and maximum power setting, which is reflected in TET, Tc and PCN values, obviously appears in Load-Following operating scenarios (Figure 20). In spring, which has the lowest maximum power setting and power setting variation, the greatest number of cycles to failure (LCF life in cycles) occurs. Whereas, winter has the lowest number of cycles to failure due to the high variation in power setting and high maximum power setting. Number of cycles to failure in winter is lower than in summer although summer has higher maximum values of TET, Tc and PCN. The reason is winter has greater variation in power settings, which reflected in TET, Tc and PCN values.

LCF life (Number of cycles to failure) is affected significantly by the value of maximum power setting and slightly by the ambient temperature, because they are

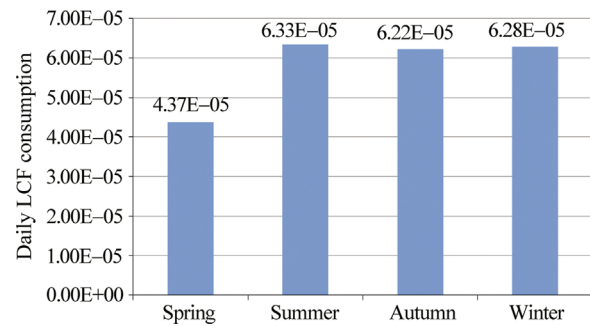

Figure 21 Daily LCF consumption for reference engine.

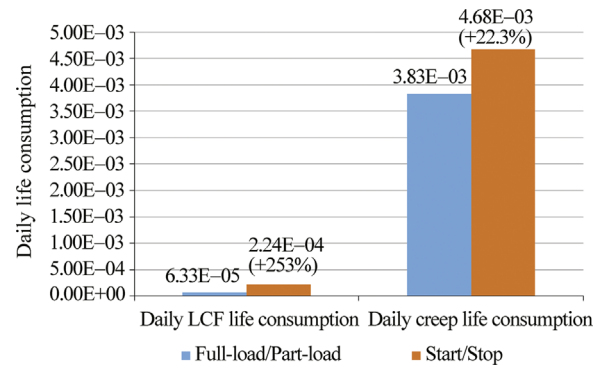

Figure 22 Summer daily LCF and creep life consumption (Load-Following and Start-Stop scenarios).

reflected in TET, Tc and PCN maximum values. Summer scenario has the lowest number of cycles to failure due to the high maximum values of TET, Tc and PCN, resulted from high power setting and high ambient temperature. Despite the fact they have similar maximum power setting, number of cycles to failure in winter is higher than it in summer regarding the lower ambient temperatures, which appears in TET, Tc and PCN maximum values. Spring still has the greatest number of cycles to failure resulted from the smallest values of TET, Tc and PCN. All these figures are reflected in daily LCF life consumption (Figure 21).

3.2.5. Start-Stop scenarios

Start-Stop scenarios were created to produce the same power profile for summer and winter as explained. The results show obvious difference in daily creep life consumption and LCF life consumption for summer (Figure 22) and winter (Figure 23).

Daily LCF life consumption is influenced by the number of cycles per day in Start-Stop scenarios. Although summer has lower LCF life in cycles due to higher ambient temperatures, winter has higher daily LCF life consumption because it has higher number of cycles per day in its operating scenario. Daily LCF life consumption increases significantly in Start-Stop scenario for summer by 253%. This is because of daily power-variation for Start-Stop scenario (from 0% to 100%) is greater than that of Load-Following scenario (from 50% to 100%), although the number of cycles per day in Start-Stop scenario is lower.

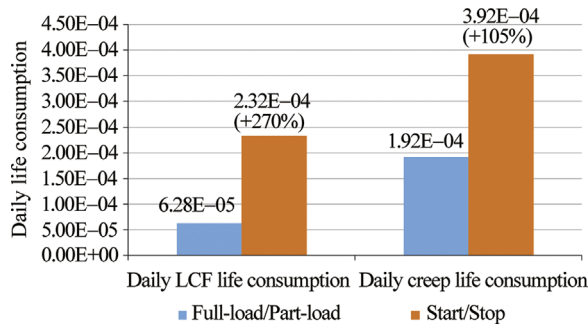

Figure 23 Winter daily LCF and creep life consumption (Load-Following and Start-Stop scenarios).

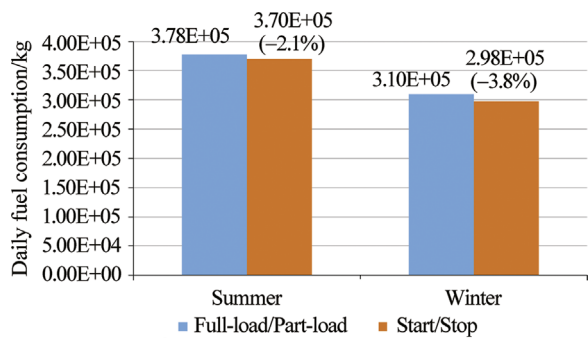

Figure 24 Daily fuel consumption for summer and winter (Load-Following and Start-Stop scenarios).

Results show that daily creep life consumption in summer is obviously greater than it in winter due to higher ambient temperatures in spite of having lower average daily operating hours in Start-Stop case. There is a slight increase in daily creep life consumption in Start-Stop scenario for summer (22.3%), whereas in winter the increase is obviously high (105%).

Finally, for both scenarios in summer and winter, the daily creep life consumption is greater than daily LCF life consumption. The reason is that all these operating scenarios do not have high number of load variation during the day. Furthermore, Load-Following scenarios have lower daily creep life consumption than Start-Stop, which gives them more opportunity to be preferred by the operator.

3.2.6. Fuel consumption

Both season and type of operating scenario have an influence on daily fuel consumption. Generally, results (Figure 24) show that summer has higher daily fuel consumption than winter, due to the longer day-peak period. Start-Stop scenarios for both summer and winter have lower daily fuel consumption. The reduction in daily fuel consumption in Start-Stop scenario for winter (3.8%) is greater than summer (2.1%). Hence, the operator can compromise between Load-Following and Start-Stop scenarios. Daily life consumption increases in Start-Stop scenario whereas daily fuel consumption decreases. So, Load-Following scenario is preferred if the operator considers gas turbine life, whereas Start-Stop scenario is preferred if the operator considers daily fuel consumption which affects the direct operating cost.

4. Conclusion

- Summer has the greatest creep life consumption due to high values of TET, Tc and PCN resulting from high power settings and high ambient temperatures.
- Although ambient temperatures during spring are higher than winter periods, it still has lower daily creep life consumption due to lower power settings.
- Creep life is affected significantly by TET and Tc values, and slightly by PCN values.
- Number of cycles to failure (LCF life) in Load-Following scenarios is affected by the maximum value of power setting and the value of variation in power setting, whereas it is affected only by the maximum value of power setting in Start-Stop scenario.
- Despite having the same maximum power setting and lower ambient temperatures compared to summer, winter has lower number of cycles to failure (LCF life) due to the greater value of daily power setting variation in Load-Following scenario.
- Regarding the difference in ambient temperatures, number of cycles to failure (LCF life) for Start-Stop scenario in winter is higher than that of summer, in spite of having the same maximum power setting.
- Daily LCF life consumption is affected by the number of cycles to failure and the number of cycles per day.
- Daily creep life consumption in summer is obviously greater than it in winter due to higher ambient temperatures in spite of having lower average daily operating hours in a Start-Stop scenario.
- For both scenarios in summer and winter, daily creep life consumption is greater than daily LCF life consumption.
- There is a slight increase in daily creep life consumption in Start-Stop scenario for summer (22.3%), whereas in winter the increase is obviously high (105%).
- Start-Stop scenario for both summer and winter has lower daily fuel consumption compared to Load-Following scenario.
- The reduction in daily fuel consumption in Start-Stop scenario compared to Load-Following scenario, for winter (3.8%) is greater than summer (2.1%).

Acknowledgements

The authors will like to appreciate the flex-e-plant consortium for providing invaluable information and Mr. Paul Lambert for his contribution towards this research.

References

- [1] M. Bonnie, Are simple cycles or combined cycles better for renewable power integration? Available at: <http://www.powermag.com/are-simple-cycles-or-combined-cycles-better-for-renewable-power-integration/>, (accessed 20.03.15).
- [2] G. Brinkman, D. Lew, P. Denholm, Impacts of renewable generation on fossil-fuel unit cycling: costs and emissions, in:

- Proceedings of the 11th International Workshop on Large-Scale Integration of Wind Power in Power Systems Proceedings, Lisbon, Portugal, 2012.
- [3] E.A. Ogiriki, Y.G. Li, T. Nikolaidis, T. Isaiah, G. Sule, Effect of fouling, thermal barrier coating degradation and film cooling holes blockage on gas turbine engine creep life, in: Proceedings of the fourth International Conference on Through-Life Engineering Services, Cranfield, UK, 2015.
- [4] Y. Assoul, S. Benbelaid, V.S. Zeravcic, G. Bakic, M. Dukic, Life estimation of first stage high pressure gas turbine blades, *Sci. Tech. Rev.* 58 (2) (2008) 8–13.
- [5] M.F. Ghafir, Y.G. Li, R. Singh, K. Huang, X. Feng, Impact of operating and health conditions on aero gas turbine hot section creep life using a creep factor approach, in: Proceedings of ASME Turbo Expo 2010, Power for Land, Sea and Air, June 14–16, 2010, pp. 1–13, Available at: (<http://dx.doi.org/10.1115/GT2010-22332>).
- [6] E.M. Harold, S.N. Todd, *Mechanical Engineers' Handbook: Energy and Power*, Third Ed., John Wiley & Sons, Inc., New York, 2006.
- [7] E.N. Saatlou, K.G. Kyprianidis, V. Sethi, P. Pilidis, On the trade-off between minimum fuel burn and maximum time between overhaul for an intercooled aeroengine, in: Proceedings of the Institution of Mechanical Engineers, Part G: Journal of Aerospace Engineering, 228 (13) 2014, 2424–2438, Available at: (<http://dx.doi.org/10.1177/0954410013518509>).
- [8] T. Isaiah, S. Dabbashi, D. Bosak, S. Sampath, G. Di-lorenzo, Life analysis of industrial gas turbines used as a back-up to renewable energy sources, *Procedia CIRP* (2015).
- [9] A.O. Abu, S. Eshati, P. Laskaridis, R. Singh, Aero-engine turbine blade life assessment using the Neu/Sehitoglu damage mode, *Int. J. Fatigue* 61 (2014) 160–169, (<http://dx.doi.org/10.1016/j.ijfatigue.2013.11.015>).
- [10] E.A. Ogiriki, Y.G. Li, T. Nikolaidis, Prediction and analysis of impact of TBC oxidation on gas turbine creep life, in: Proceedings of ASME Turbo Expo 2015, Power for land, Sea and Air, June 15–19, Palais des Congress, Montreal, Canada, 2015, pp. 1–13.
- [11] E.A. Ogiriki, *Effects of Environmental Factors on a Gas Turbine Engine Creep Life and Performance*, Cranfield University, , England, 2015.
- [12] B.M. Reports, U.K. National Grid Status, 2014.
- [13] WU Weather Underground, 2015.
- [14] W.L. Macmillan, *Development of a Modular-type Computer Program for the Calculation of Gas Turbine Off-design Performance*, Cranfield University, , England, 1974.
- [15] D.S. Pascovici, F. Colmenares, S.O.T. Ogaji, P. Pilidis, An economic and risk analysis model for aircrafts and engines, ASME Turbo Expo 2007, Power for Land, Sea, and Air, American Society of Mechanical Engineers, 2007, pp. 103–116.
- [16] K.G. Kyprianidis, R.F. Colmenares Quintero, D.S. Pascovici, S.O.T. Ogaji, P. Pilidis, A.I. Kalfas, EVA: a tool for environmental assessment of novel propulsion cycles, in: Volume 2: Controlsdiagnostics and Instrumentation, Cycle Innovations, Electric Power, 2008, pp. 547–556, (<http://dx.doi.org/10.1115/GT2008-50602>).
- [17] B. Nkoi, P. Pilidis, T. Nikolaidis, Performance of small scale aero-derivative industrial gas turbines derived from helicopter engines, *Propuls. Power Res.* 2 (4) (2013) 243–253.

2016-08-12

Life cycle evaluation of an intercooled gas turbine plant used in conjunction with renewable energy

Isaiah, Thank-God

Elsevier

Thank-God Isaiah, Siddig Dabbashi, Dawid Bosak, Suresh Sampath, Giuseppina Di Lorenzo, Pericles Pilidis, Life cycle evaluation of an intercooled gas turbine plant used in conjunction with renewable energy, Propulsion and Power Research, Volume 5, Issue 3, September 2016, Pages 184-193

<http://dx.doi.org/10.1016/j.jprr.2016.07.005>

Downloaded from Cranfield Library Services E-Repository