

Effect of Electromagnetic Treatment on Fatigue Resistance of 2011 Aluminum Alloy

M.A. Mohin^{1,a}, H. Toofanny^{1,b}, A. Babutskyi^{1,c}, A. Lewis^{1,d}, and Y.G. Xu^{2,e*}

¹School of Engineering and Technology, University of Hertfordshire, AL10 9AB, UK

²School of Aerospace, Transport and Manufacturing, Cranfield University, MK43 0AL, UK

^am.mohin@herts.ac.uk,

^bhasift93@hotmail.co.uk,

^ca.babutskyi@herts.ac.uk,

^da.lewis@herts.ac.uk, ^e*yigeng.xu@cranfield.ac.uk (*corresponding author)

Keywords: electromagnetic treatment, fatigue resistance, aluminum alloy

Abstract. Beneficial effects of the electromagnetic treatment on fatigue resistance were reported on several engineering alloys. These could be linked to the dislocation activity and the rearrangement of the crystal structure of the material under the electromagnetic field, resulting in delayed crack initiation. This paper presents an experimental study on the effect of pulsed electromagnetic treatment on the fatigue resistance of 2011 aluminum alloy. Circular cantilever specimens with loads at their ends were tested on rotating fatigue machine SM1090. Fatigue lives of treated and untreated specimens were analyzed and compared systematically. It has been found that the effect of the pulsed electromagnetic treatment on the fatigue resistance is dependent on the intensity of the pulsed electromagnetic field and the number of the treatment applied. Clear beneficial effect of the pulsed electromagnetic treatment on the fatigue resistance of the aluminum alloys has been observed, demonstrating a potential new technique to industries for fatigue life extension.

Introduction

The study of the effect of the electromagnetic field (*EMF*) treatment on the resistance to fatigue damage in sheet metals hasn't received much attention by the fatigue research community, but has nevertheless been in discussion for many years. For example, an increase of the fatigue life of low-carbon steel following pulsed magnetic field pre-treatment was reported in [1]. An increase of more than 50% in fatigue limit was reported for stainless steel after a pulsed electric current pre-treatment [2]. The capacity of *EMF* treatment for fatigue damage repairing has been reported in which medium-carbon steel was fatigue-tested and then exposed to a magnetic field to repair fatigue damage [3]. An increase in fatigue life of up to 34% was observed for the treated specimens compared with those without the treatment. The beneficial effect of pulsed electric current treatment on fatigue resistance was also reported for a titanium alloy which was ultrasonically treated to obtain surface compressive residual stresses and then subjected to pulsed electric current treatment followed by fatigue testing. This approach gave a 25-50% increase in the fatigue life after pulsed electric current treatment [4]. It is clear from these findings that *EMF* treatment can improve the resistance to fatigue damage of metals.

The beneficial effect of *EMF* treatment on metal fatigue resistance can be related to the phenomenon of the natural concentration of current in the vicinity of a crack and to the subsequent Joule heating at that location. The application of a pulsed electric current of high density ($>10kA/mm^2$) can improve the fatigue resistance of metals through crack tip blunting (Fig.1(a)) [5], phase transformation (Fig.1(b)) [6] and healing of an open crack as shown in Figs.1(c) and 1(d) [7]. Other mechanisms proposed to explain the effect of *EMF* treatment include the affected dislocation activity and the rearrangement of the crystal structure delaying crack initiation. This paper presents an experimental study on the effect of pulsed electromagnetic treatment on the fatigue resistance of aluminum 2011 alloy. Fatigue lives of treated and untreated specimens were compared to investigate the effect of the intensity of the pulsed electromagnetic field, the number of the treatment, and the level of the pre-treatment fatigue damage on their fatigue resistance.

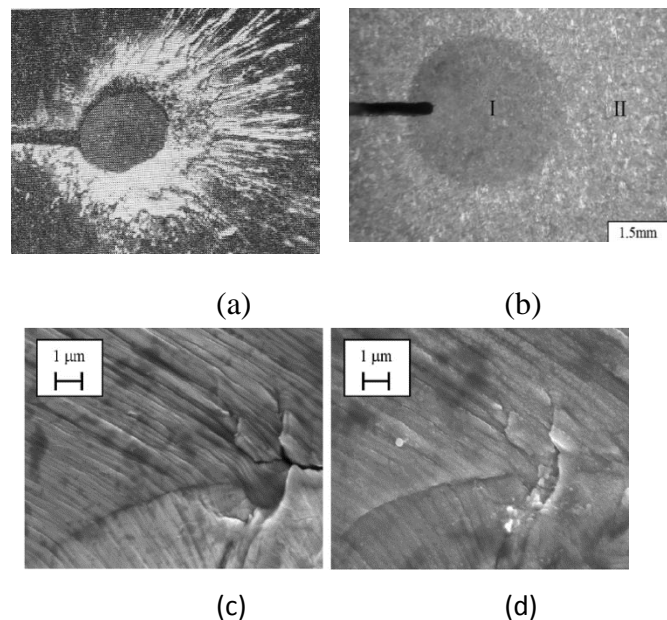

Fig.1 Effect of *EMF* treatment: (a) crack tip blunting [5], (b) phase transformation [6], and (c-d) crack healing (c – open crack before the treatment; d – closed crack after the treatment) [7].

Experimental Setup

Table 1 shows the chemical composition of 2011 aluminium alloy chosen for the study. 2011 alloy is typically used for fasteners, fittings, artillery and the trim on vehicles due to its high mechanical strength and good machining ability yet poor weldability. The ultimate tensile strength (UTS) of 2011 aluminium alloy is 365MPa.

Element	Al	Si	Fe	Cu	Pb	Bi	Zn	Other
%	91.25	0.4	0.7	6	0.6	0.6	0.3	0.15

Table 1 2011 Aluminium Alloy Composition [8].

Fig.2(a) shows the SM1090 Rotating Fatigue Machine with the sample clamped in place as a cantilever and loaded at the other end. Fig.2(b) shows the sample geometry for the test.

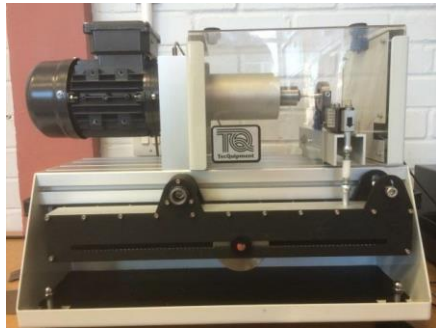

(a)

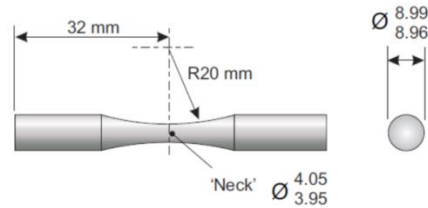

(b)

Fig.2 (a) SM1090 rotating fatigue machine, (b) fatigue sample geometry.

Fig.3 is a schematic diagram of the pulsed electromagnetic treatment rig developed at the Materials Lab, University of Hertfordshire. It consists of a high voltage supplier which, when switched on, allows the capacitor of $200\mu\text{F}$ to collect and hold charge ready to be pulsed through the circuit and induce an electromagnetic field around the fatigue sample.

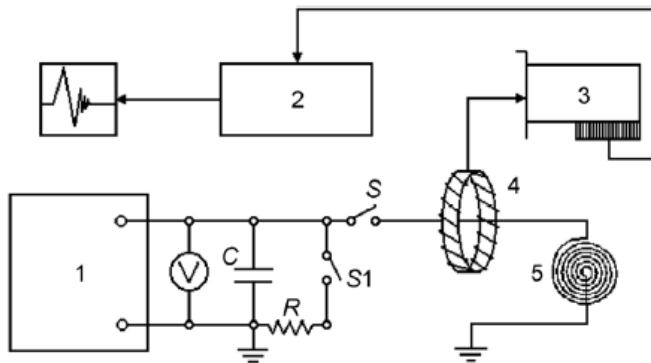

Fig.3 Diagram of pulsed *EMF* treatment circuit: 1 – high voltage supplier, 2 – processing software, 3 – analogue to digital convertor, 4 – coil, 5 – inductor, C – capacitor, R – ballast resistor, S – switches.

Results and Discussions

(a) Effect of Pulsed *EMF* Treatment Intensities on Fatigue Resistance

Three 2011 aluminium alloy samples were tested under the stress amplitude of 225MPa which

is 62% of the UTS of the material. The average number of cycles to failure over the three untreated samples was 153 000 cycles, which is used as the baseline fatigue life of the material in this study.

Three 2011 aluminium alloy samples were then treated under three pulsed *EMF* treatment intensities (low – 2kV, medium – 2.5kV, high – 3kV) and compared with the baseline fatigue life to assess the effects of the intensity of electromagnetic treatment on fatigue resistance. All the treated samples were pre-fatigue-damaged to 70% of the baseline cycles by applying 107 000 cycles of loading before the pulsed electromagnetic treatment. The pulsed *EMF* treatment was applied three times for each sample and the samples were then fatigued to failure.

Fig.4 shows the beneficial effect of treatment intensities on the fatigue resistance of the 2011 aluminium alloy samples. Under a low treatment intensity of 2kV, the sample failed at 203000 cycles which is 33% higher than the untreated sample. Under a medium treatment intensity of 2.5kV, the sample failed at 176000 cycles which is 15% higher than the untreated sample. Under a high treatment intensity of 3kV, the sample failed at 197200 cycles which is 29% higher than the untreated sample.

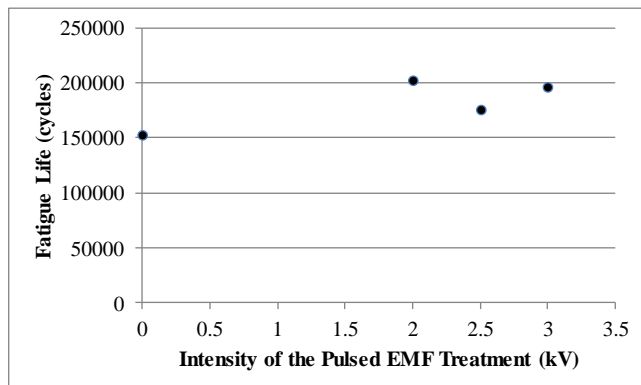

Fig.4 Effect of pulsed *EMF* treatment intensity on fatigue resistance of 2011 aluminium alloy.

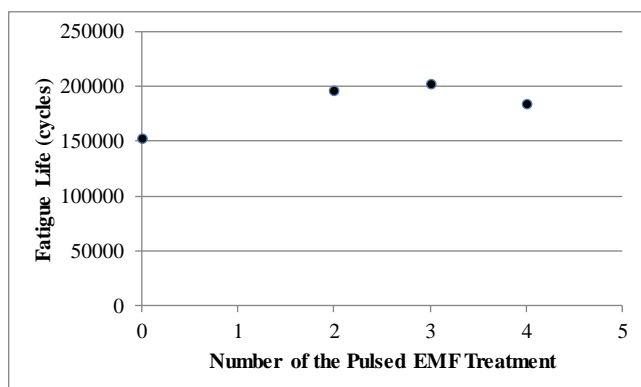

Fig.5 Effect of pulsed *EMF* treatment times on fatigue resistance of 2011 aluminium alloy.

It is however noticed that, while the beneficial effect of the treatment on fatigue resistance is clear, the correlation coefficient of the data was found to be -0.212 indicating that no correlation exists between an increasing intensity of treatment and fatigue resistance. This could be caused by the limited number of samples used in the current study and further investigation is underway.

(b) Effect of the Number of Treatment on Fatigue Resistance

Fig.5 shows the effect of the number of the pulsed EMF treatment on the fatigue resistance of the 2011 aluminium alloy samples. Similar to the study of the treatment intensity, all the treated samples were pre-fatigue-damaged to 70% of the baseline cycles by applying 107 000 cycles of loading before the pulsed electromagnetic treatment. The pulsed *EMF* treatment was then repeated under the same intensity of 2kV for two, three, and four times, respectively.

With two applications of electromagnetic treatment, the cycles to failure increased compared to the untreated baseline average by 28% at 196700 cycles. With three applications of electromagnetic treatment, the cycles to failure increased compared to the untreated baseline average by 33% at 203 000 cycles. With four applications of electromagnetic treatment, the cycles to failure increased compared to the untreated baseline average by 20% at 184 000 cycles.

The beneficial effect of the pulsed *EMF* treatment on fatigue resistance is again clear. The correlation coefficient of the data was found to be -0.669 indicating a reasonable negative correlation exist between the number of treatments and fatigue resistance. This implies that excessive *EMF* treatment may introduce additional fatigue damage and hence optimum treatment parameters should be identified to exploit the full potential of the technique. There may also be a treatment saturation point over which the treatment may have little or no effect of the fatigue resistance of the material. The optimum treatment parameter and the possible saturation point will be dependent on the material type and the sample size. Further investigation including the micro-hardness test and microstructural observation should be carried out to understand the effect of *EMF* treatment on the fatigue resistance of the aluminium alloy.

Conclusions

An experimental study was carried out on the effect of pulsed electromagnetic treatment on the fatigue resistance of 2011 aluminum alloy. Following conclusions can be made after the comparison of the fatigue lives of treated and untreated specimens under various treatment conditions:

- Clear beneficial effects of the pulsed electromagnetic treatment on the fatigue resistance of the aluminum alloys have been observed. The improvement on the fatigue resistance is dependent on the intensity of the pulsed electromagnetic field and the number of the treatment applied.
- Excessive EMF treatment may introduce additional fatigue damage and hence reduce the beneficial effect of the pulsed EMF treatment on fatigue resistance.
- Optimum treatment parameters and the possible treatment saturation point are dependent on the material type and the sample size. Further tests together with the micro-hardness and microstructural characterization are required to clarify these.

References

- [1] O.A. Troitskii (1984), The electroplastic effect in metals, *Strength of Materials*, vol.16, p.277-81.
- [2] G.V. Stepanov, V.V. Kharchenko, A.A. Kotlyarenko, A.I. Babutskyi (2013), Effect of pulsed magnetic field treatment on the fracture resistance of a cracked specimen, *Strength of Materials*, vol.45, p.154-62.
- [3] H. Conrad (2005), Enhanced phenomena in metals with electric and magnetic fields: I Electric fields, *Materials Transactions*, vol.46, p.1083-7.
- [4] H. Conrad (2002), Thermally activated plastic flow of metals and ceramics with an electric field or current, *Mater. Sci. Eng.: A*, vol.322, p.100-7.
- [5] V.M. Finkel, Yu I. Golovin, A.A. Sletkov (1976), About possibility of deceleration of rapid cracks by current pulses, *Proceedings of the USSR Academy of Sciences*, vol.227, p.848-51.
- [6] H.Q. Lin, Y.G. Zhao, Z.M. Gao, L.G. Han (2008), Effects of pulse current stimulation on the thermal fatigue crack propagation behavior of CHWD steel, *Mater. Sci. Eng.: A*, vol.478, p.93-100.
- [7] A. Hosoi, T. Nagahama, Y. Ju (2012), Fatigue crack healing by a controlled high density electric current field, *Mater. Sci. Eng.: A*, vol.533, p.38-42.
- [8] Aalco.co.uk, (2015). *Aluminium Alloy - Commercial Alloy - 2011 T4 Rod and Bar*. (http://www.aalco.co.uk/datasheets/Aluminium-Alloy-2011-T4-Rod-and-Bar_3.ashx).

2016-08-08

Effect of electromagnetic treatment on fatigue resistance of 2011 aluminum alloy

Mohin, M. A.

World Scientific Publishing

Mohin, A. et al. Effect of electromagnetic treatment on fatigue resistance of 2011 aluminium alloy, *Journal of Multiscale Modeling*, Volume 7, Issue 3, 2016, Article number 165004

<http://dx.doi.org/10.1142/S1756973716500049>

Downloaded from Cranfield Library Services E-Repository