



CoA Memo. No. 201

September, 1969

THE COLLEGE OF AERONAUTICS
DEPARTMENT OF AIRCRAFT DESIGN

The measurement of biaxial strains in coated
fabric materials using the disc-replica method

- by -

J. Webb

and

D.M. Richards

Inflated Structures Report C.1206/1

Summary

A method of measuring biaxial strains in coated fabric type materials is presented whereby the strain is deduced from the distortion of a circular impression made on the material. The impression is placed on the material when loaded, enabling all measurements to be made with the material in its relaxed, unloaded, state.

The method is simple to use, and requires a minimum of equipment.

Notation

	x, y	reference or fabric axes
	x', y'	apparent principal strain axes
	$\epsilon_{Rx}', \epsilon_{Ry}'$	residual strains in the $x'y'$ directions
	$\epsilon_{Tx}', \epsilon_{Ty}'$	true strains in the $x'y'$ directions
	$\epsilon_{Tx}, \epsilon_{Ty}$	true strains in the xy directions
	θ	apparent angle between xy and $x'y'$ axes
	θ'	true angle between xy and $x'y'$ axes
	d	correction angle to θ for residual effects
See	d	basic impression diameter
Fig. 3	{ a_1b_1 a_2b_2	sizes of datum spot in the y,x directions
		sizes of reference spot in the x,y directions
	l_1l_2	initial sizes of grid in y,x directions
	$l_1'l_2'$	final sizes of grid in y', x' directions
	f,c,r',r	see Fig. 4
	$A =$	$l_1'l_2' - l_2l_1$



1.1 Introduction

Conventional methods of measuring strain become unsuitable when dealing with fabric, or similar materials, because not only are the strains involved generally very large, but also the presence of a bonded strain gauge may seriously influence the local stiffness of the material.

Although grids marked directly onto the fabric have been employed to measure strains in these materials, these have the disadvantage that the grid distortions must be measured with the structure in its loaded state, which may be difficult on curved surfaces.

The 'Disc Replica' method, presented here, overcomes these difficulties. It will cope with large strains, does not influence the stiffness of the material, and all measurements are taken with the structure unloaded. Furthermore, the method is simple to use: and the only specialised measuring equipment required is a low-powered travelling microscope.

2.1 Disc Replica Method

Two techniques are available:-

- i) 'Double Spot' technique
- ii) 'Spot and Grid' technique.

The most suitable technique to use in a given case will depend on the initial (no load) stiffness of the material, and the rapidity with which the strain changes from point to point in the loaded structure.

2.1.2. Double Spot Technique

The method is shown diagrammatically in Fig. 1. The steps involved are:-

- (a) Small circular discs of, say, 0.25 ins. diameter are cut from adhesive plastic tape, using a hollow punch.
- (b) In the region of the structure where strain is to be measured, an orthogonal grid is marked, (in the case of a single ply fabric material, it is convenient if the grid axes coincides with the fabric axes).
- (c) With the structure unloaded, and unpressurised in the case of an inflated structure, a disc is stuck into place, approximately over a grid intersection previously marked. French chalk is now brushed over the disc onto the surrounding material, and the disc removed, leaving a circular impression.
- (d) The structure is now pressurised and loaded, and allowed to stand for a few minutes to allow creep strains to settle. A further circular impression is marked on the structure as above, adjacent to the original (reference) impression.

(e) Finally, the structure is unloaded and depressurised. The impressions from steps (c) and (d) will now be elliptical in shape, and the major and minor axes of these ellipses are measured, using, say, a travelling microscope. The angle between the marked axes and the principal ellipse axes of the second (loaded state) impression is also measured. Note that all measurements are taken with the material laid flat, and unloaded. The initial (unloaded state) impression provides a measure of the residual strain in the structure. Creep recovery becomes unimportant, therefore, providing that any pair of impressions is measured within a reasonably short time interval.

For low initial stiffness materials, it may be better to preload the structure slightly before making the first impression, since this removes uncertainties with regard to gauge length. In this case, the preloaded state becomes the datum state for strain measurement.

2.1.2 'Spot and Grid' Technique

The method is shown diagrammatically in Fig. 2. The steps in the technique are:-

- (a) With the structure in its unloaded and unpressurised state, a grid is marked out on it locally in the region where the strain is to be measured. The grid size is then measured. (Note: for single ply fabrics it is convenient if the grid coincides with the fabric axes).
- (b) The structure is now pressurised and loaded, and allowed to stand for a few minutes to allow creep strains to settle. A disc is now placed on the structure at a grid intersection, and using french chalk, an impression is made. The disc is now removed.
- (c) The structure is now unloaded and depressurised, and the major and minor axes of the ellipse resulting from the disc impression measured. The angle between the ellipse axes and grid is also measured, and finally the grid size itself is measured again as a check on residual strains. As in the previous method, all measurements are taken with the material laid flat.

3.0 Analysis of Results

3.1 Double Spot Technique

Fig. 3 illustrates the appearance of the two spots after testing. Fig. 3(a) showing the final state of the first (datum) impression, and Fig. 3(b) the final state of the second (loaded) impression.

Using the notation of Fig. 3, it can be shown that the residual strains in the x' and y' directions are respectively:

$$\left. \begin{aligned} \epsilon_{Rx}' &= \frac{a_1 - (a_1 - b_1)\cos^2\theta - d}{\alpha} \\ \epsilon_{Ry}' &= \frac{(a_1 - b_1)\cos^2\theta + b_1 - d}{\alpha} \end{aligned} \right\} \quad (1)$$

The true strains in the x' and y' are now:-

$$\left. \begin{aligned} \epsilon_{Tx}' &= \frac{(a_1 - a_2) - (a_1 - b_1)\cos^2\theta}{a_2} \\ \epsilon_{Ty}' &= \frac{(a_1 - b_1)\cos^2\theta + (b_1 - b_2)}{b_2} \end{aligned} \right\} \quad (2)$$

Due to residual strains, θ is not the true angle between the principal strain directions and the reference directions.

From Fig. 4, if α is the correction to be applied to θ then since

$$\frac{f}{d} = \frac{c}{b_1} = \frac{\sin\theta - d\cos\theta}{\cos\theta + d\sin\theta} \quad \text{for small } d$$

$$d = \frac{\left(\frac{b_1}{a_1} - 1\right)\cot\theta}{\frac{b_1}{a_1}\cot^2\theta + 1}$$

and true angle $\theta' = \theta - \alpha$ $\theta' = \theta - \alpha$

The true strains in the x and y directions (fabric directions for single ply materials) are now:-

$$\begin{aligned} \epsilon_{Tx} &= \frac{(1 - \cos 2\theta')}{2a_2b_2} \left\{ (a_1a_2 - a_2b_1)\cos^2\theta + a_2b_1 \right\} \\ &+ \frac{(1 + \cos 2\theta')}{2a_2b_2} \left\{ (b_1b_2 - a_1b_2)\cos^2\theta + a_1b_2 \right\} - 1 \\ \epsilon_{Ty} &= \frac{(1 + \cos 2\theta')}{2a_2b_2} \left\{ (a_1a_2 - a_2b_1)\cos^2\theta + a_2b_1 \right\} \\ &+ \frac{(1 - \cos 2\theta')}{2a_2b_2} \left\{ (b_1b_2 - a_1b_2)\cos^2\theta + a_1b_2 \right\} - 1 \end{aligned} \quad (4)$$

and shear strain in the x and y directions.

$$\gamma_{xy} = \frac{\sin 2\theta'}{a_2b_2} \left\{ \cos^2\theta' (a_1a_2 - a_2b_1 + a_1b_2 - b_1b_2) + a_2b_1 - a_1b_2 \right\}$$

When $\theta = 0$, $\theta' = 0$, the principal strains are in the x and y direction and

$$\epsilon_{Tx} = \frac{b_1}{a_2} - 1, \quad \epsilon_{Ty} = \frac{a_1}{b_2} - 1, \quad \gamma_{xy} = 0 \quad (5)$$

3.2 'Spot and Grid' Technique

Fig. 2 illustrates the information obtained from the spot and grid technique. The process of analysing the results is similar to that used in the previous method.

Using the notation of Fig. 2, it can be shown that the true strains in the x'y' directions are, after correcting for residual strains,

$$\left. \begin{aligned} \epsilon_{Tx}' &= \frac{d}{a_2 l_1 l_2} \left\{ l_1' l_2 - A \cos^2 \theta \right\} - 1 \\ \epsilon_{Ty}' &= \frac{d}{a_2 l_1 l_2} \left\{ l_2' l_1 + A \cos^2 \theta \right\} - 1 \end{aligned} \right\} \quad (6)$$

where $A = l_1' l_2 - l_2' l_1$

The correction to be applied to θ for residual strains

$$d = \left(\frac{l_2}{l_1} - 1 \right) \cot \theta / \left(\frac{l_2}{l_1} \cot^2 \theta + 1 \right) \quad (7)$$

where true angle $\theta' = \theta - d$ as before.

The true strains in the x and y directions are

$$\left. \begin{aligned} \epsilon_{Tx} &= \frac{d}{a_2 b_2 l_1 l_2} \left\{ a_2 \sin^2 \theta' (A \cos^2 \theta + l_2' l_1) \right. \\ &\quad \left. + b_2 \cos^2 \theta' (l_1' l_2 - A \cos^2 \theta) \right\} - 1 \\ \epsilon_{Ty} &= \frac{d}{a_2 b_2 l_1 l_2} \left\{ a_2 \cos^2 \theta' (A \cos^2 \theta + l_2' l_1) \right. \\ &\quad \left. + b_2 \sin^2 \theta' (l_1' l_2 - A \cos^2 \theta) \right\} - 1 \end{aligned} \right\} \quad (8)$$

and the shear strain relative to the xy directions

$$\gamma_{xy} = \frac{d \sin 2\theta'}{a_2 b_2 l_1 l_2} \left\{ A \cos^2 \theta (a_2 + b_2) + a_2 l_2' l_1 - b_2 l_1' l_2 \right\}$$

When $\theta = \theta' = 0$, the principal strains coincide with the xy directions and

$$\epsilon_{Tx} = \frac{l_2'}{l_2} \frac{d}{a_2} - 1, \quad \epsilon_{Ty} = \frac{l_1'}{l_1} \frac{d}{b_2} - 1, \quad \gamma_{xy} = 0 \quad (9)$$

4.0 Application of Method to a Tensile Test

Uniaxial tensile tests have been carried out on two specimens (062") wide single ply neoprene coated nylon fabric (Dunlop PR7987). The strains on one specimen were measured by the 'Double Spot' technique and on the other using the 'Spot and Grid' technique. In both cases the strains were measured independently by simply measuring the change in length of a known gauge length, using dividers.

The weft direction of the fabric corresponded with the direction of loading in both cases, and since this material has zero initial stiffness in this direction, it was found to be beneficial to preload the material to 5 lb/ins for the 'Double Spot' test, and to use this as the datum strain level. This preloading tends to remove inaccuracies due to handling the material in its unstrained state. The 'Spot and Grid' technique does not lend itself to such preloading, of course, since it is usually difficult to measure the grid size with the specimen loaded.

The discs used for creating chalk impressions were cut from 'Lassotape' adhesive backed P.V.C. tape, using a hollow punch.

The disc impression size (diameter 'd' in Figs. 1 and 2) was taken as 6.47 m.m., this size being based on a statistical survey of 100 disc impressions (see Appendix 1).

All measurements of grid and impression sizes were carried out using a travelling microscope.

The test procedures followed that outlined in para. 2.2 and 2.3.

The results of the test on specimen 1 ('Double Spot' method) are plotted in Graph 1, and those for the test on specimen 2 ('Spot and Grid' method) in Graph 2; in both cases the results obtained by measurement with dividers have been shown for comparison.

5.0 Conclusions

A method of strain measurement for fabric type materials has been presented, and experimental strains obtained in this way compared with those measured with dividers over a known gauge length. The results show reasonable correlation.

Of the two techniques employed, the 'Double Spot' method is the easier to use, and is also to be preferred where the material has a low initial stiffness. On the other hand, where greater accuracy is required, and where the material has a stress-strain relationship with a finite initial slope, the 'Spot and Grid' technique is the more satisfactory.

Appendix I

Errors in Disc and Impression Sizes

A survey of 100 disc diameters and their corresponding chalk impressions has been carried out in order to:

- (a) assess the variation of chalk impression diameter compared with disc diameter.
- (b) determine a mean diameter of the chalk impressions for use in subsequent calculations.

The discs were cut from 'Lassotape' adhesive backed P.V.C. tape, and were stuck onto a strip of neoprene coated nylon fabric in random orientations. The diameters of the discs were measured using a travelling microscope.

The same discs were used to create chalk impressions on the fabric, french chalk and a soft brush being used for this purpose. The diameters of the chalk impressions, after removing the discs, were measured, using the microscope as before.

The results of this survey are shown in graphs 3 and 4, which show histograms of frequency v. measured size for the discs and impressions respectively.

From these graphs for the discs:-

mean dia. = 6.438 m.m.
standard deviation = 0.0416 m.m.
- (0.647% of mean dia.)

and for the impressions:

mean dia. = 6.471 m.m.
standard deviation = 0.0827 m.m.
- (1.28% of mean dia.)

Thus, 95% of the measured chalk impressions will lie within $\pm 2.56\%$ of the mean size (6.438 m.m.).

FIG 1 - 'DOUBLE SPOT' METHOD

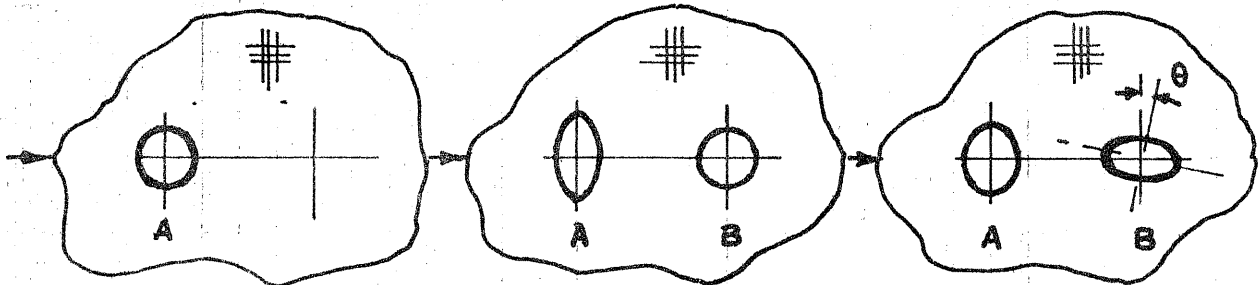

1. REFERENCE AXES MARKED ON STRUCTURE ALIGNED WITH FABRIC DIRECTIONS; WITH STRUCTURE UNLOADED OR PRELOADED IMPRESSION 'A' IS MARKED ON FABRIC USING FRENCH CHALK & ADHESIVE DISC. DISC REMOVED AFTER MARKING

2. STRUCTURE IS LOADED & IMPRESSION 'B' IS MARKED ON FABRIC - DISC IS REMOVED AFTER MARKING.

3. STRUCTURE IS UNLOADED & DEFLATED - MAJOR & MINOR AXES OF ELLIPSES 'A' & 'B' ARE MEASURED - ANGLE θ MEASURED.

FIG 2 - 'SPOT & GRID' METHOD

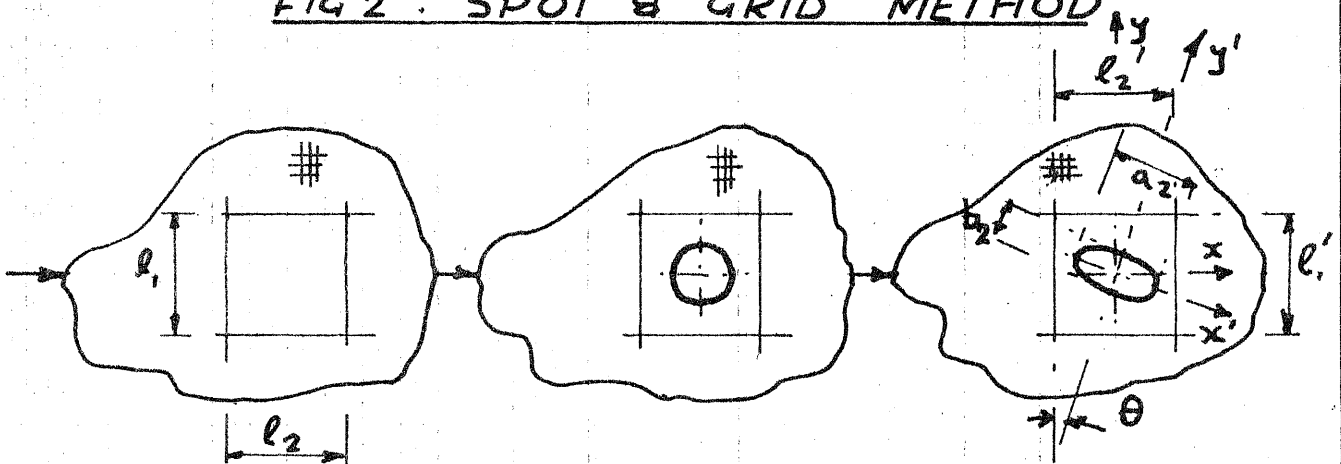

1. GRID MARKED ON STRUCTURE ALIGNED WITH FABRIC DIRECTIONS - STRUCTURE IN UNLOADED UNPRESSURISED STATE - & LENGTHS l_1, l_2 MEASURED

2. STRUCTURE LOADED & DISC IMPRESSION MARKED ON - DISC IS REMOVED AFTER MARKING.

3. STRUCTURE IS UNLOADED & DEFLATED - LENGTHS l_1', l_2' - a_2, b_2 & ANGLE θ ARE MEASURED.

FIG 3 . STRAIN DATA FROM 'DOUBLE SPOT' METHOD

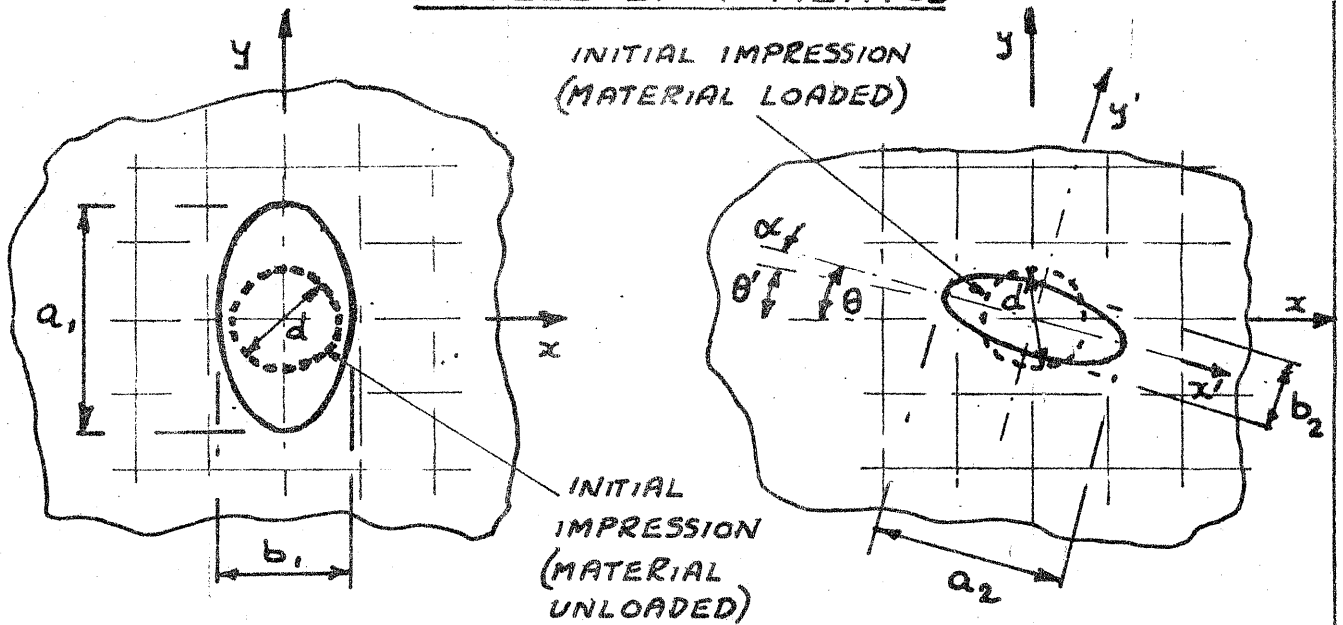
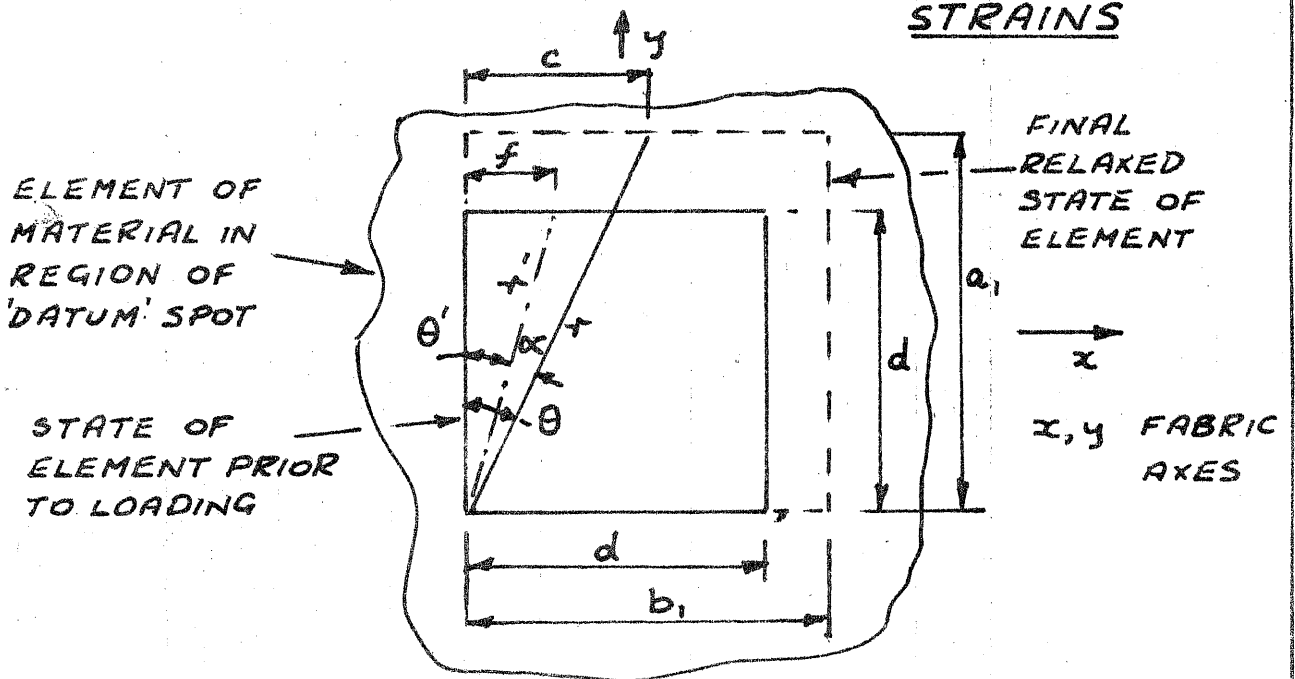
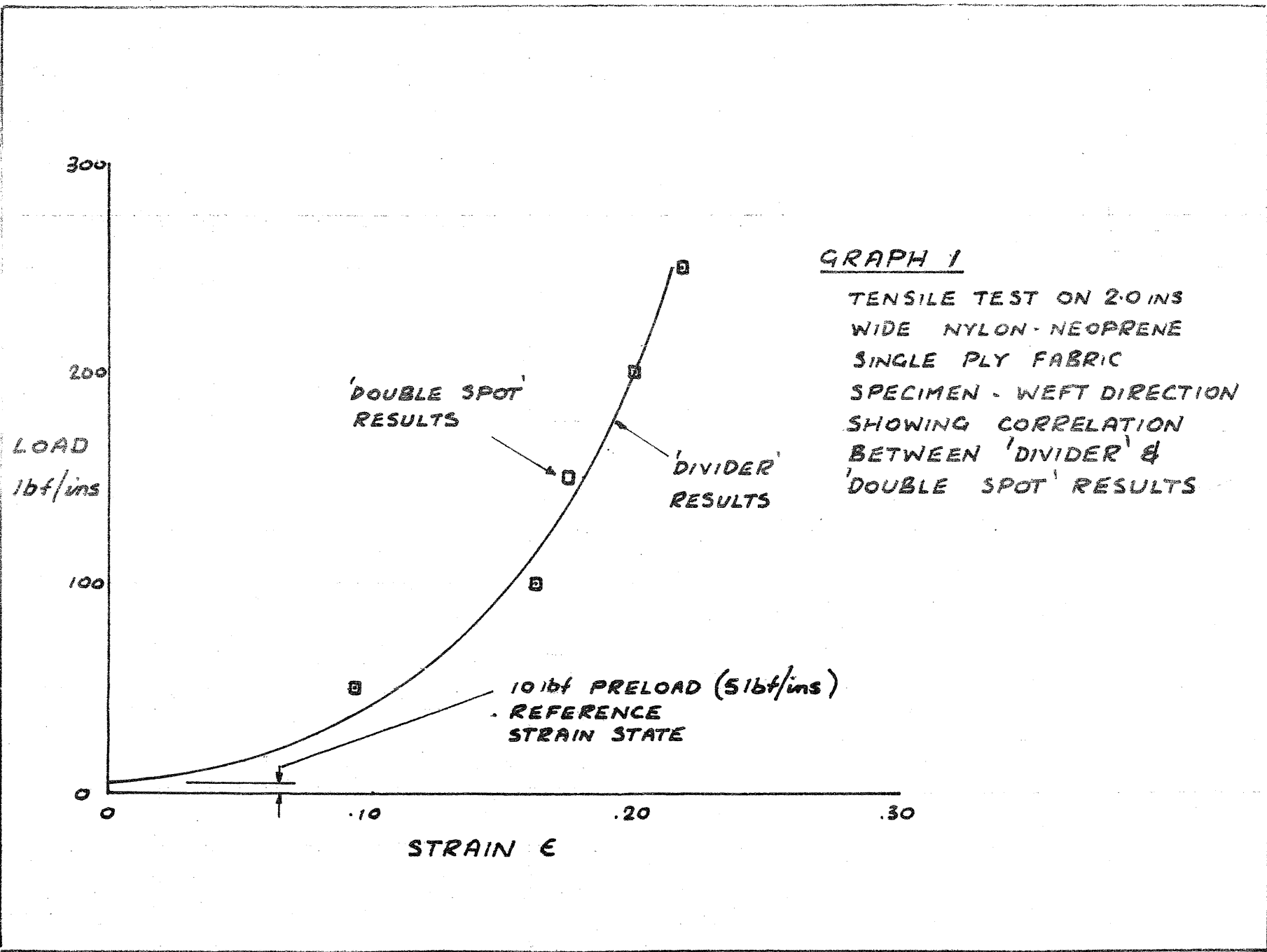

FIG 3a - 'DATUM' SPOT WITH STRUCTURE FINALLY RELAXED

FIG 3b - 'STRAIN' SPOT WITH STRUCTURE FINALLY RELAXED

FIG 4. CORRECTION TO θ DUE TO RESIDUAL STRAINS





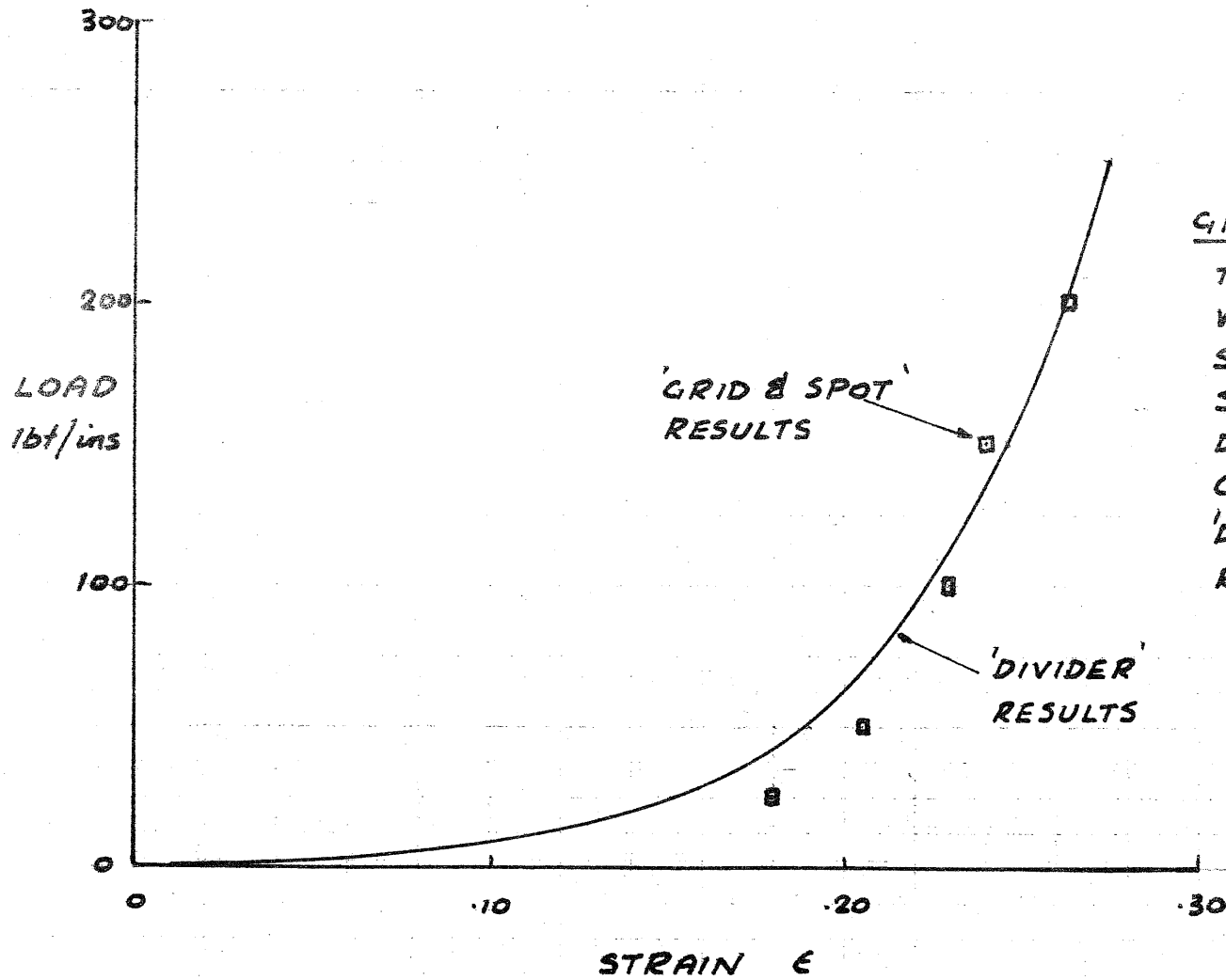

GRAPH 2

TENSILE TEST ON 2.0ins
WIDE NYLON-NEOPRENE
SINGLE PLY FABRIC
SPECIMEN - WEFT
DIRECTION - SHOWING
CORRELATION BETWEEN
'DIVIDER' & 'GRID & SPOT'
RESULTS

