

3 8006 10058 0631

REPORT No 75  
September, 1953

THE COLLEGE OF AERONAUTICS  
CRANFIELD

Note on the development of a trailing-edge flap  
as a stall-detector.

by

C.F.BETHWAITE, B.Sc., A.F.R.Ae.S.

S U M M A R Y

A trailing-edge flap protruding slightly outside the wing profile has been developed as a stall detector and flight trials on "Anson" and "Provost" aircraft have proved successful. The device gave an adequate stall warning for all conditions of power and landing flaps and operated satisfactorily prior to stalls from steep turns. It was easily adjusted to give any desired warning speed to an accuracy of 1 m.p.h. and gave a two-stage warning, a preliminary warning preceding the final warning by about 3 m.p.h.

---oOo---

EAG.

LIST OF CONTENTS

1. Introduction
2. Description of stall-detector
3. Flight trials of stall-detector
  - 3.1 "Anson" flight tests
  - 3.2 "Provost" flight tests
4. Discussion
5. Conclusions

References

Figures 1-9

--oOo--

## 1. INTRODUCTION

Certain aspects of the problem of artificial stall-warning have been investigated recently at the College of Aeronautics. The investigation was initiated as second year student research, but the latter part of it was covered by a research contract placed by the Ministry of Supply. An earlier report (ref.1) suggested that an on-coming stall might be detected by a small flap located near the trailing-edge of the wing in a region where reversal of airflow occurred just before the stall. A device of this type has now been flight-tested on an Anson aircraft and the results of these tests are discussed in this report. Brief check tests on a Percival Provost are also reported.

## 2. Description of stall-detector

A small metal flap was mounted near the trailing-edge of the wing so that it protruded outside the wing profile normal to the airstream. The flap was free to rotate against the spring-loaded plunger of a "break" micro-switch, i.e. continuity in the switch was broken when the plunger was depressed. The flap was mass-balanced about its axis of rotation. At low angles of incidence the aerodynamic load on the flap pressed it backwards, depressing the plunger of the switch. At incidences near the stall when a break-away occurred near the trailing-edge with a corresponding loss of total head, the aerodynamic loads on the flap were reduced, until, finally, the spring-loaded plunger was released and continuity was completed within the switch. This was connected in series with a suitable stall-indicator. The incidence at which this occurred- the "warning incidence"- could be adjusted either by adjusting the leverage of the plunger about the axis of rotation of the flap or by adjusting the length of flap protruding outside the wing profile. The principle of the stall-detector is illustrated in fig.1, and figs. 3 and 4 show the unit mounted on the Anson and Provost respectively. An obvious criticism of the system described is that the warning circuit was completed when the aircraft was taxiing or at rest, since the aerodynamic loads on the flap were then low (or zero). This defect was eliminated by including an undercarriage micro-switch in the warning circuit, so that the system was not energised when the wheels were on the ground.

The detector unit is illustrated in fig.2, but it should be remembered that this particular unit is a prototype and a version properly designed for production would be much neater.

## 3. Flight trials of stall-detector

Comprehensive flight trials of the detector were carried out on an Anson aircraft, followed by brief check trials on a Percival Provost. The results are given in fig. 5 to 9 and are discussed below.

### 3.1 Anson flight tests

The stall-detector was fitted to an Anson Mark I in a spanwise position just outboard of the landing flaps and propeller disc where wool tufts indicated a flow breakaway just before the stall. The detector was located at 75% of the local wing chord aft of the leading-edge (fig.3) and was connected in series with the stick-shaker described in ref.1. The effects of adjusting the length of the detector-flap protruding outside the wing profile are illustrated in fig.5 for various configurations of landing flaps and throttle setting. Fig.6 illustrates the similar effects of adjusting the micro-switch plunger in relation to the axis of rotation of the detector

flap. Comparing the individual curves of figures 5 & 6 it can be seen that the warning margin (expressed in m.p.h. as excess of warning-speed over stalling-speed) was reasonably independent of landing flap position, but the margin was greater in the case of a powered stall. This was not considered undesirable since the powered stall on the Anson is more violent than the power-off stall and a greater warning margin may be an asset. This particular feature was probably associated with the spanwise location of the detector. The salient point, however, is that for any configuration the margin was adequate without being embarrassingly large.

The warning in all cases occurred in two stages; an initial warning, in which the stick-shaker operated spasmodically, preceded the full warning by about 3 m.p.h. This feature is probably characteristic of this type of stall-detector, and may be due to the spasmodic nature of the breakdown of flow just before the stall. It was regarded as advantageous by the pilots who flew the aircraft.

It is clear from fig.5 and 6 that this type of detector can easily be adjusted to operate over a wide range of speeds. Movement of the micro-switch through 8 mms. relative to the axis of rotation of the flap caused a change in warning speed of about 15 m.p.h. so that it should be possible to adjust warning speed to an accuracy of about 1 m.p.h. Trimming the length of flap may be useful as a preliminary adjustment.

It was suggested that a less objectionable excrescence on the wing would be presented if the detector flap was bent backwards rather than sticking out normally to the wing profile. Fig.7 illustrates the results obtained when the protruding flap of the stall-detector was bent backwards through  $30^\circ$ . For any particular length of flap the warning speed achieved with the bent flap was higher than that obtained with the straight flap; the effect of bending the flap is comparable with the effect of trimming the straight flap. Detailed comparison of fig.5 and 7 indicates that the warning margin achieved with a flap of length "1" bent backwards through  $30^\circ$  is approximately equal to that achieved with a straight flap of length " $1 \cos 30^\circ$ ". In other respects the bent flap worked in the same way as the straight flap.

### 3.2 Provost Flight Tests.

In order to extend the tests to a different type of aircraft the detector was installed in a Percival Provost. This aircraft was only available for a short period and the tests were therefore necessarily restricted. Wool tufts indicated a pre-stall breakaway of flow over the inboard portion of the wing; this was probably due to a leading edge root spoiler fitted to the aircraft. The detector was therefore installed in the position indicated in fig.4, and was included in the circuit of a warning light in the cockpit.

The effect of varying the micro-switch setting was investigated, and the results are illustrated in fig.8. The warning margin was reasonably independent of power setting but was reduced by lowering the flaps. These features are most likely associated with the location of the detector (it is behind the propeller disc and immediately ahead of a very large slotted flap). It must be remembered that this choice of location was entailed by the presence of a spoiler which induced the initial flow breakaway at the wing root. It would have been desirable to have searched for a more convenient location with this spoiler removed, but the aircraft was only available for a very short time. As in the case of the Anson an initial warning occurred about 3 m.p.h. before the final warning, but to preserve clarity this is not indicated in fig.8.



In order to assess acceleration effects on the stall detector the Provost test programme included stalls from turning flight. The results of these tests are illustrated in fig.9. Two micro-switch settings were covered, and it can be seen from fig.9 that the warning margin was reasonably independent of normal acceleration.

The important outcome of the tests is that an adequate and satisfactory stall-warning margin was obtained on the Provost and, indeed, this was confirmed by the College pilots who flew the aircraft and by the test pilots of Percival Aircraft Co Ltd., who were invited to check the stall-detector.

#### 4. Discussion

Any form of stall-detector is a safety device, and the fundamental requirements to be observed are therefore simplicity and reliability. It is noteworthy that these features are often inseparable. Deference must be paid to the aircraft designer who strives to reduce aerodynamic drag to a minimum, and, finally, although economy may not be a primary requirement it should not be ignored. Contemporary research into the problem of stall-warning has resulted in several other types of detector, particularly the leading-edge flap (Safe Flight-detector, ref.2) and the pressure-ratio switch(ref.3). It is useful to consider the trailing-edge flap in comparison with these, noting the particular virtues of each individual type.

On the questions of simplicity and reliability it is evident that there is little to choose between the leading-edge and trailing edge flaps. In this respect it is considered that either of these devices is preferable to a pressure-ratio switch which involves a fairly delicate capsule arrangement. The initial choice of location and subsequent adjustment of a leading-edge detector was discussed in ref. 1, and it is apparent from this report that the trailing-edge detector responds to similar adjustments. It is noteworthy that in the cases of the Anson and Provost a single wool-tuft exploration of the airflow was sufficient to decide the initial location of the trailing-edge flap.

The trailing-edge device provides a less objectionable excrescence on the wing-section than the leading-edge flap, though, in this respect, both are inferior to the pressure-ratio switch connected to wing-surface pressure holes. It is felt that on a high-speed aeroplane the leading-edge device may accelerate the onset of shock-wave disturbances. This possibility does not apply seriously to the trailing-edge flap.

It has been suggested that the trailing-edge flap may be more susceptible to accidental damage than either of the other two devices. This is not completely logical and it is useful to note that moderate deformation of the flap is not serious (as illustrated by a comparison of the results obtained from the straight and bent flaps).

Although no direct evidence exists it is probable that the trailing-edge flap would be subject to less serious wing icing effects than either of the other two detectors. Perhaps the greatest advantage of the trailing-edge detector lies in the fact that it produces a "two-stage" warning. For example, the possibility of using the initial stage of the warning as an approach speed indicator is very attractive.

5. Conclusions

- (i) A small flap protruding outside the wing profile near to the trailing-edge provides a simple and satisfactory stall-detector.
- (ii) Flight trials on two different types of aircraft - an Anson and a Provost - indicate that a satisfactory stall-warning margin can be obtained in all configurations of throttle setting and landing-flaps.
- (iii) This trailing-edge type of stall-detector can be adjusted conveniently to operate at any desired warning speed to within an accuracy of about 1 m.p.h.
- (iv) The Provost trials showed that the margin obtained in the case of a stall from a steep turn is similar to that obtained in a straight stall.
- (v) There is no advantage to be gained by bending the flap backwards instead of having it protruding normal to the wing profile.
- (vi) The trailing-edge detector seems to have certain advantages over some contemporary types. It entails a less objectionable discontinuity in the wing section than a leading-edge flap and will probably be less prone to icing difficulties. It is simpler and less delicate than a pressure-ratio switch operating from wing-surface pressure tappings. Furthermore, it provides a two-stage warning, the initial warning occurring about 3 m.p.h. before the final warning in the present tests.

REFERENCES.

- 1. BETHWAITE & LANGLEY Notes on research into some aspects of stall-warning devices. College of Aeronautics Report No 72.
- 2. PORT, W. The "Safe Flight" stall warning indicator. R.A.E. Tech Memo Aero 307
- 3. YOUNGMAN, R.T Development of a pre-stall detector for aircraft. S & T Memo 6/52 (July, 1952).

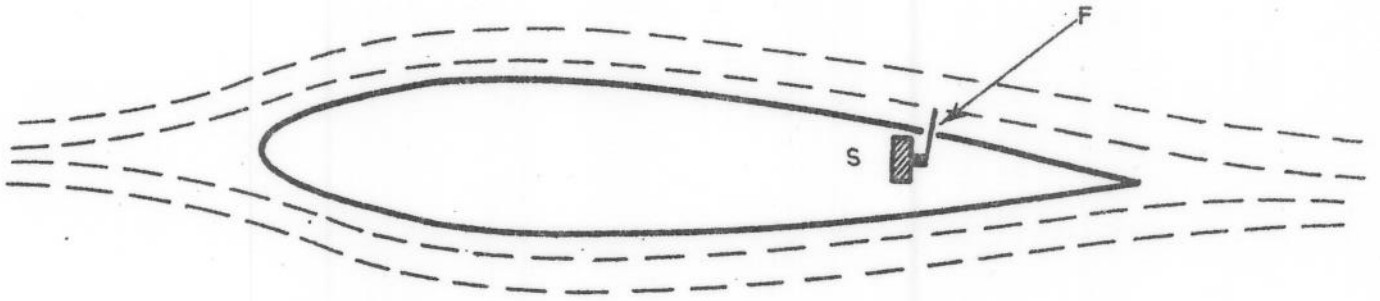

- (a) WING AT LOW INCIDENCE. FLAP "F" IS FORCED BACKWARDS AND DEPRESSES SPRING-LOADED PLUNGER OF MICRO-SWITCH "S", BREAKING CONTINUITY.

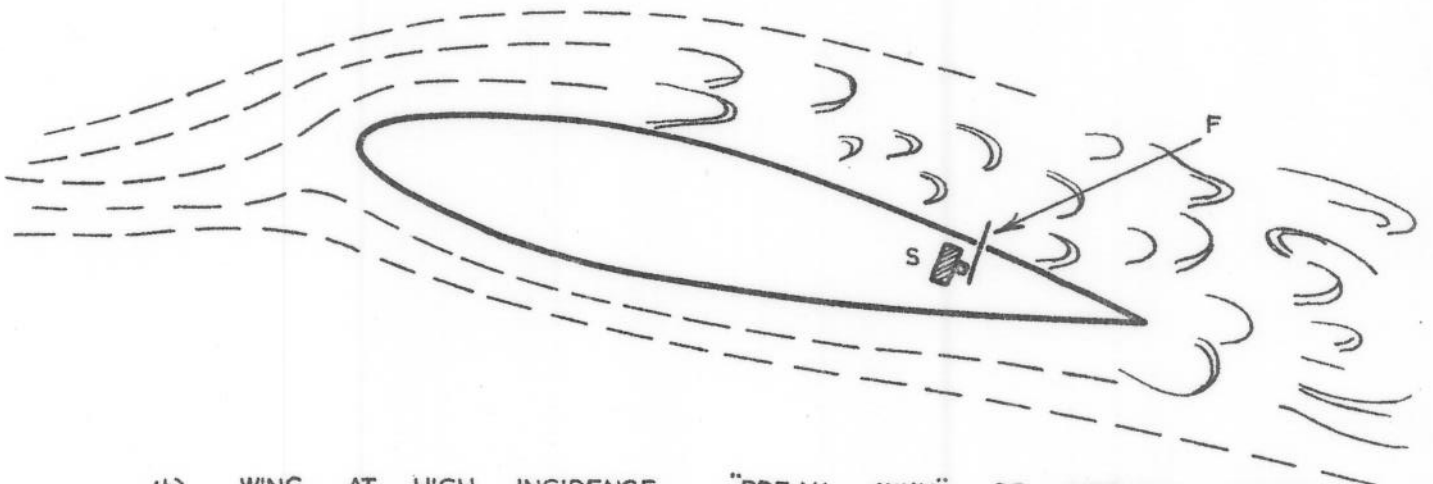

- (b) WING AT HIGH INCIDENCE. "BREAK AWAY" OF AIRFLOW OCCURS NEAR TRAILING EDGE, FLAP "F" IS MOVED FORWARD, RELEASING PLUNGER OF SWITCH AND CONTINUITY IS MADE.

PRINCIPLE OF TRAILING-EDGE STALL DETECTOR.

"The unit is mounted near the trailing edge of the wing so that the main part is inside the wing with the detector flap protruding outside the wing profile. The photograph illustrates the prototype unit; a much neater production version has now been manufactured."

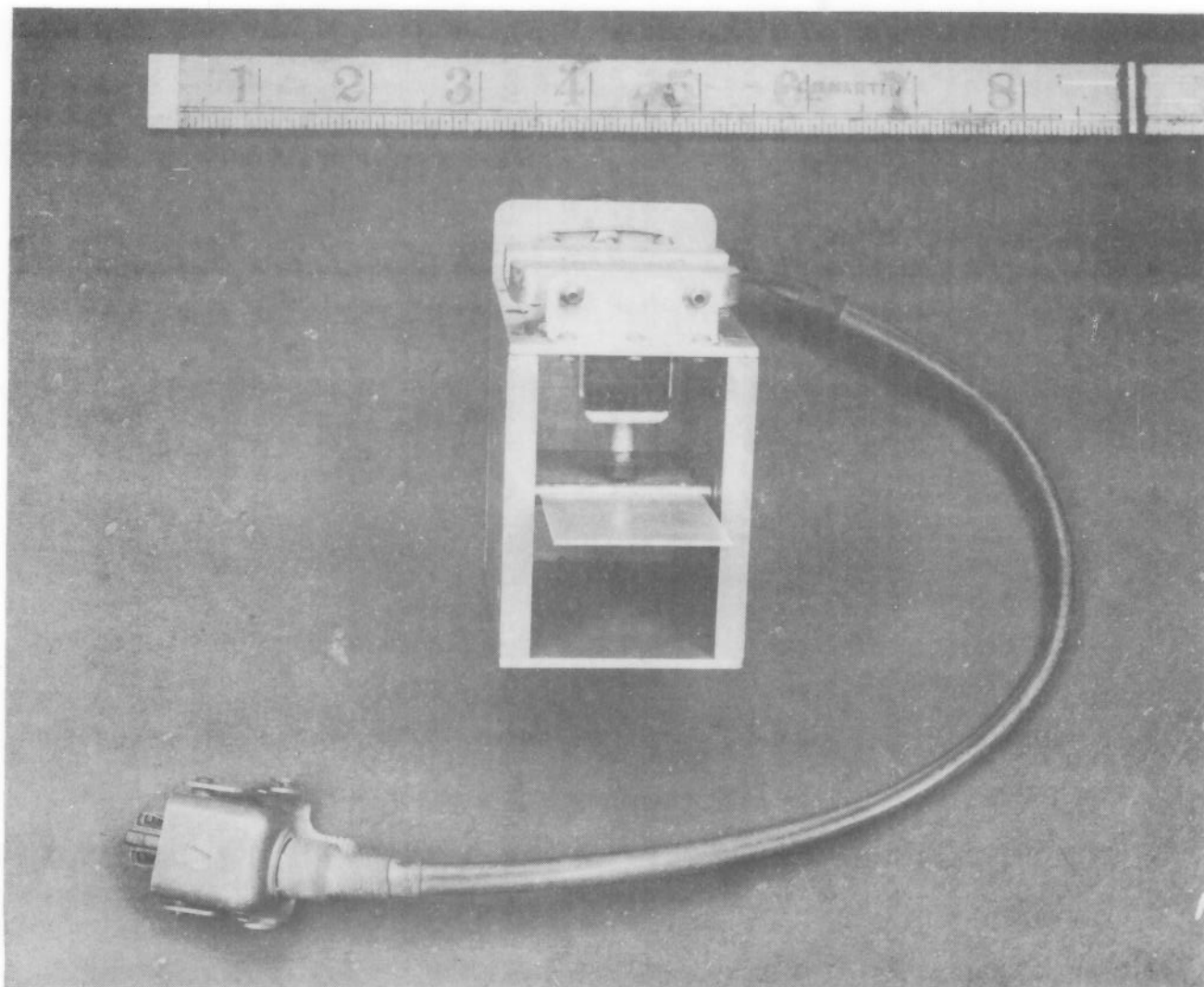

STALL DETECTOR UNIT

FIG 2



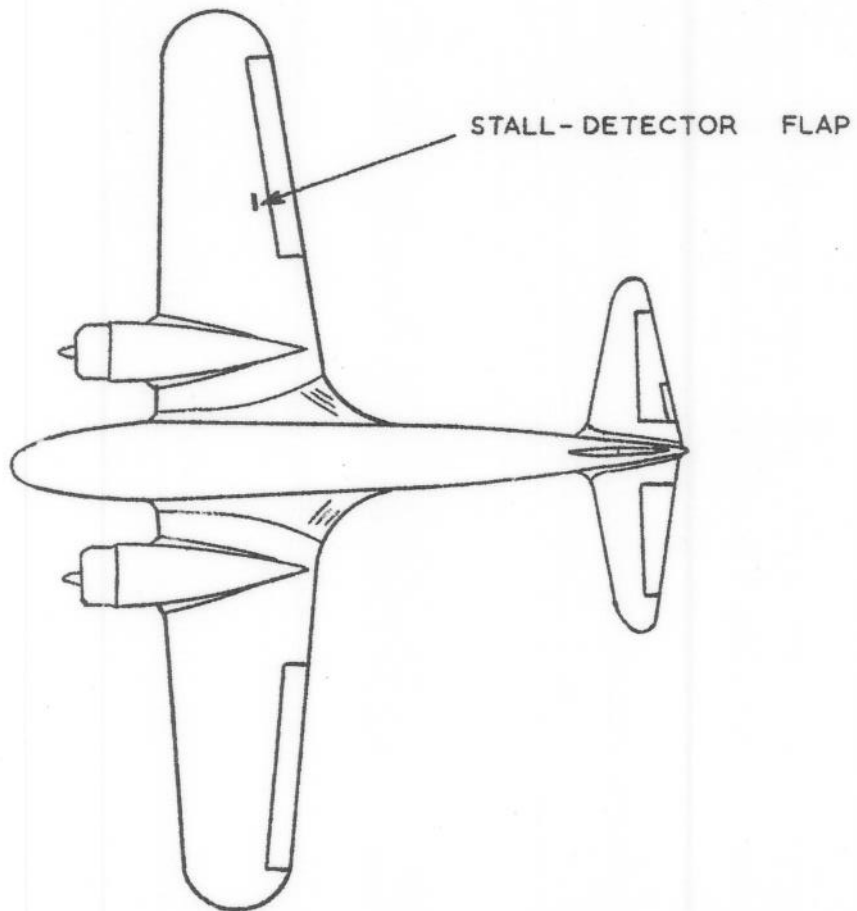
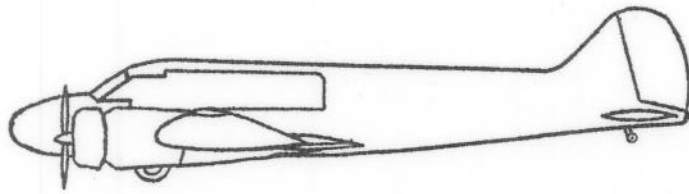
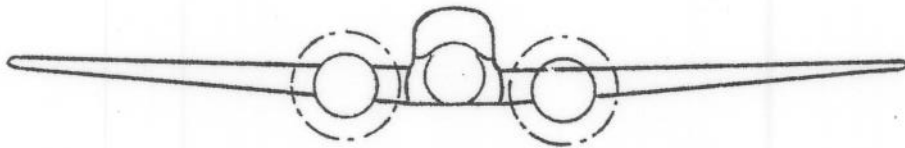

ANSON I.

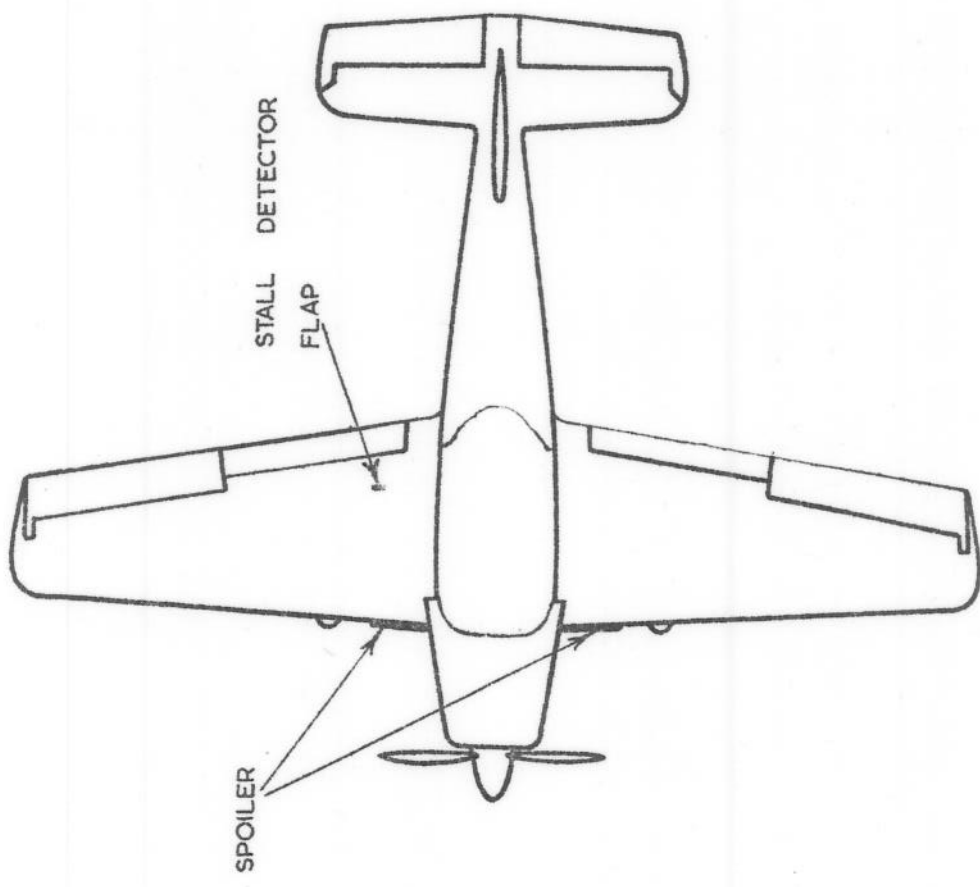
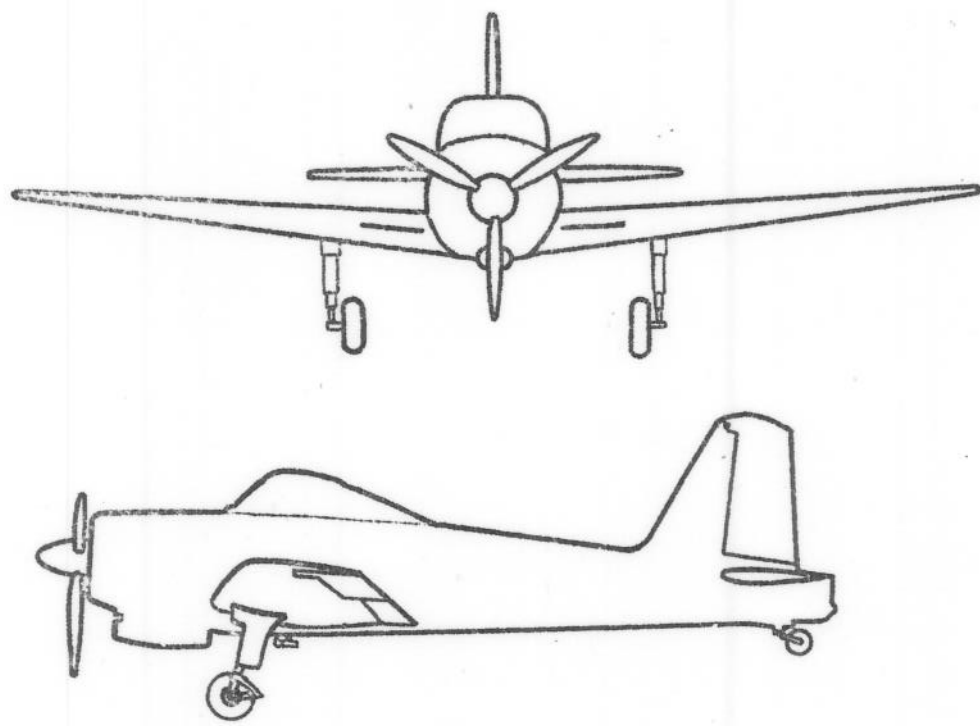

PERCIVAL "PROVOST"

FIG. 5.

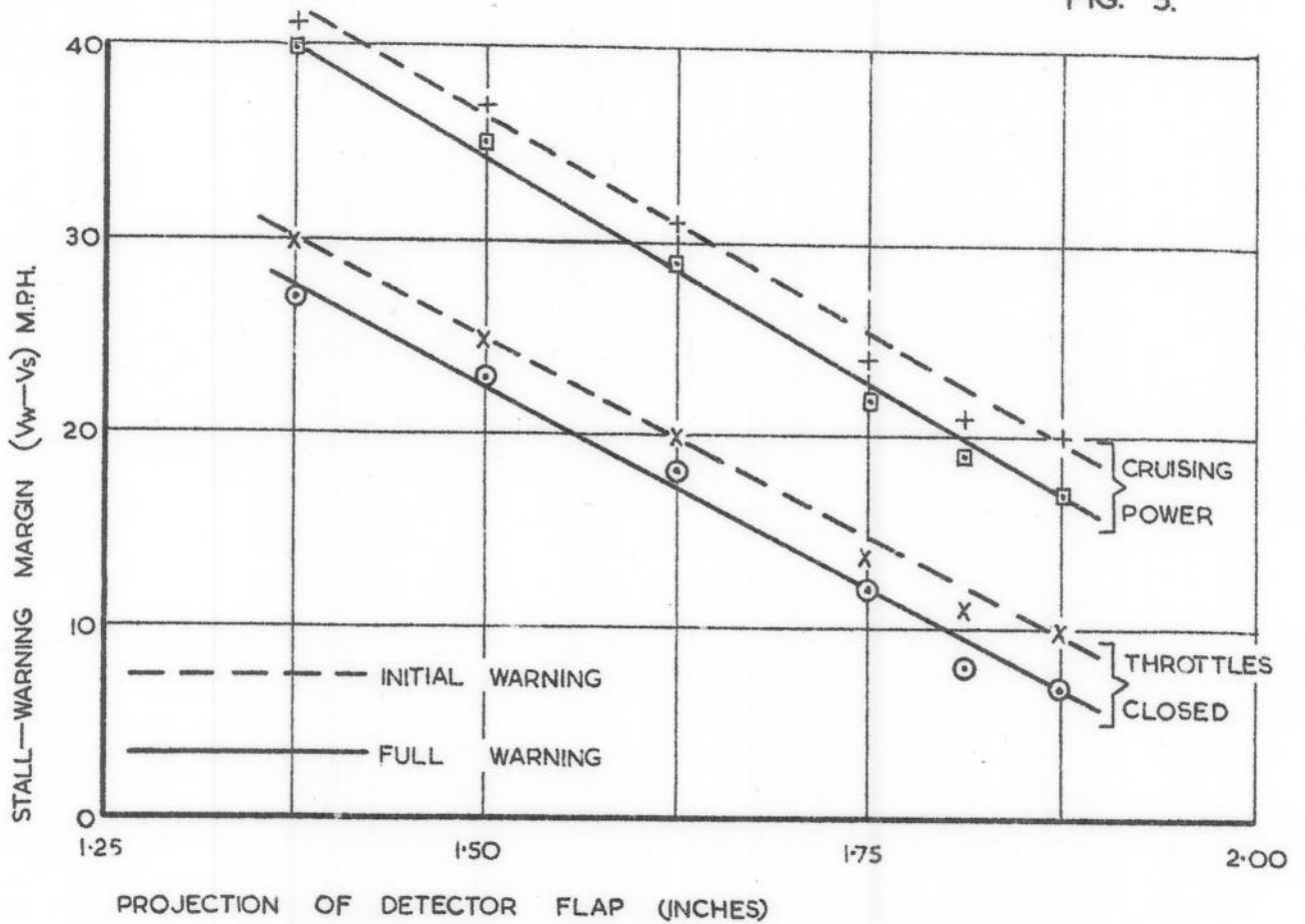

(a) LANDING FLAPS UP

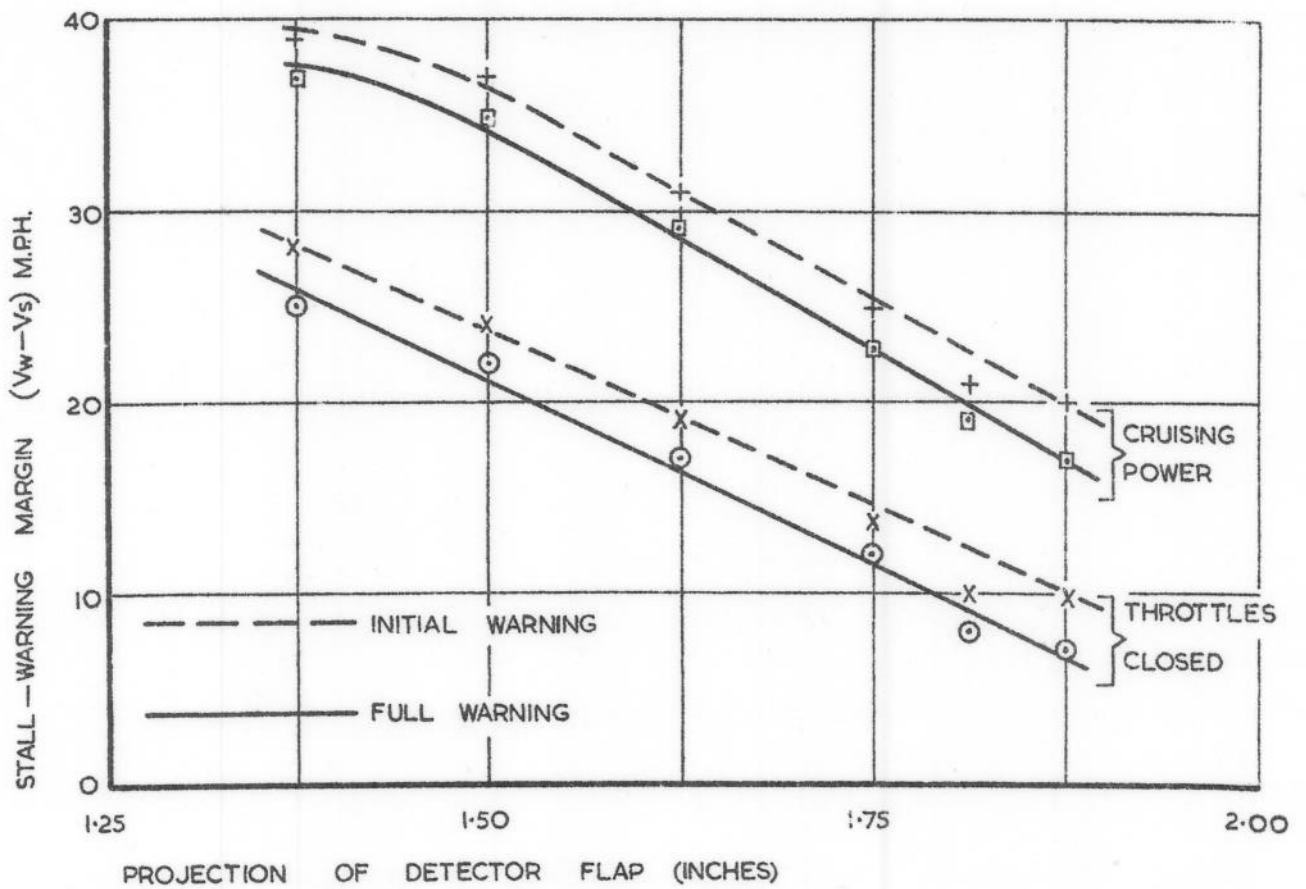

(b) LANDING FLAPS 60° DOWN

EFFECT OF LENGTH OF STRAIGHT DETECTOR FLAP ON STALL—  
WARNING MARGIN — "ANSON"  
(MICRO—SWITCH POSITION = 0 I.E. AT DATUM POINT)

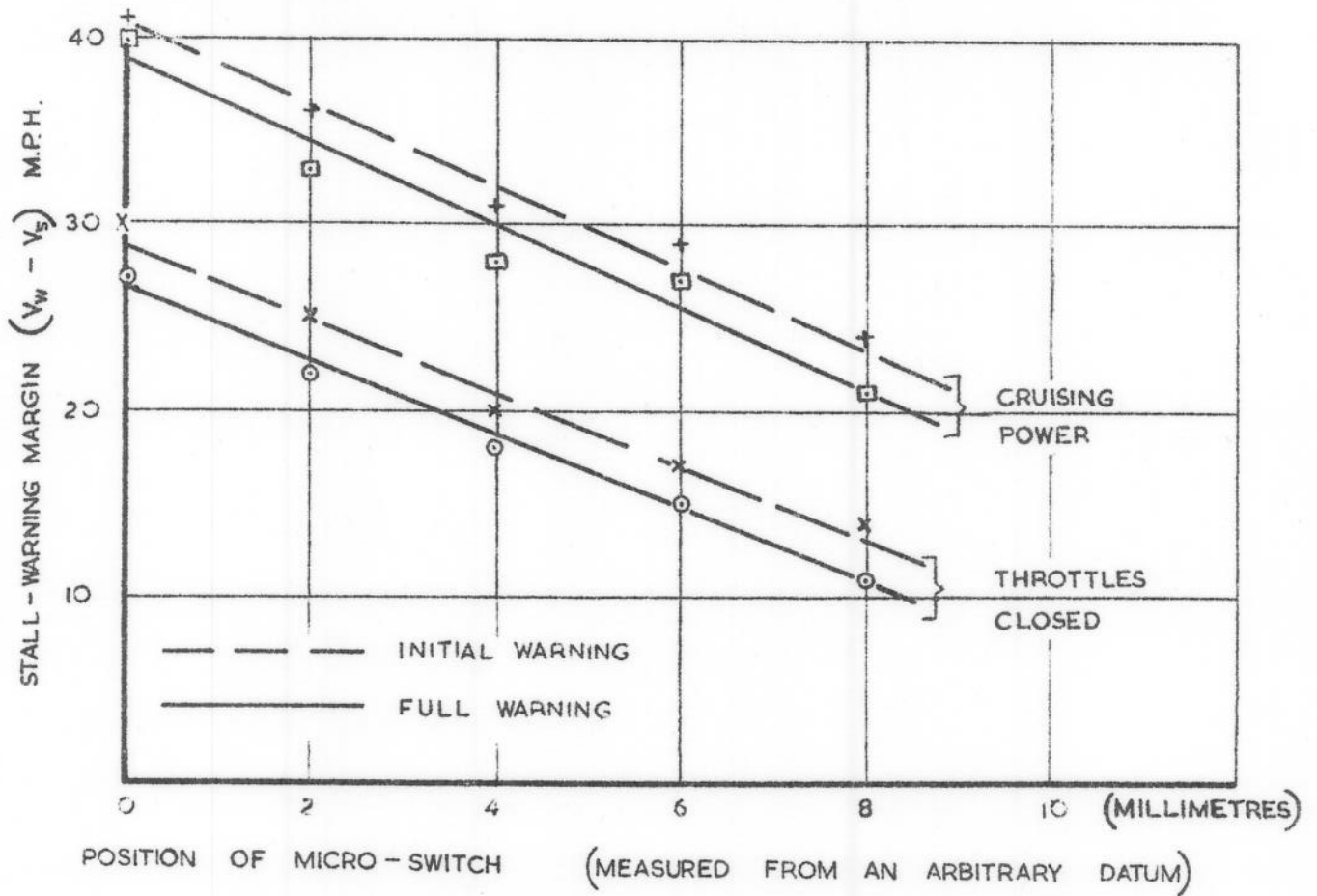

(a) LANDING FLAPS UP

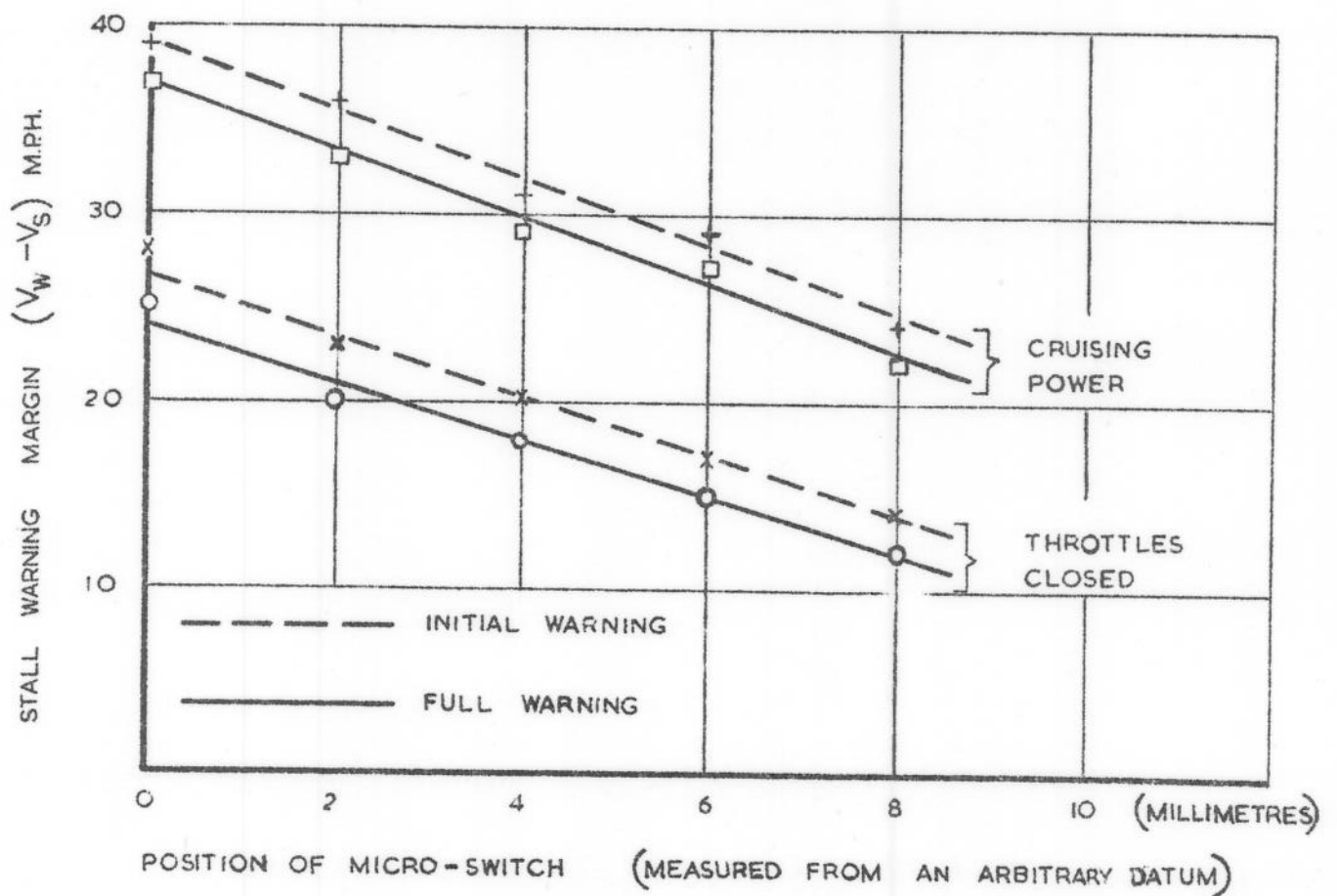

(b) LANDING FLAPS 60° DOWN

EFFECT OF MICRO-SWITCH ADJUSTMENT ON  
STALL-WARNING MARGIN — "ANSON"  
(PROJECTION OF STRAIGHT STALL DETECTOR FLAP = 1 3/8")

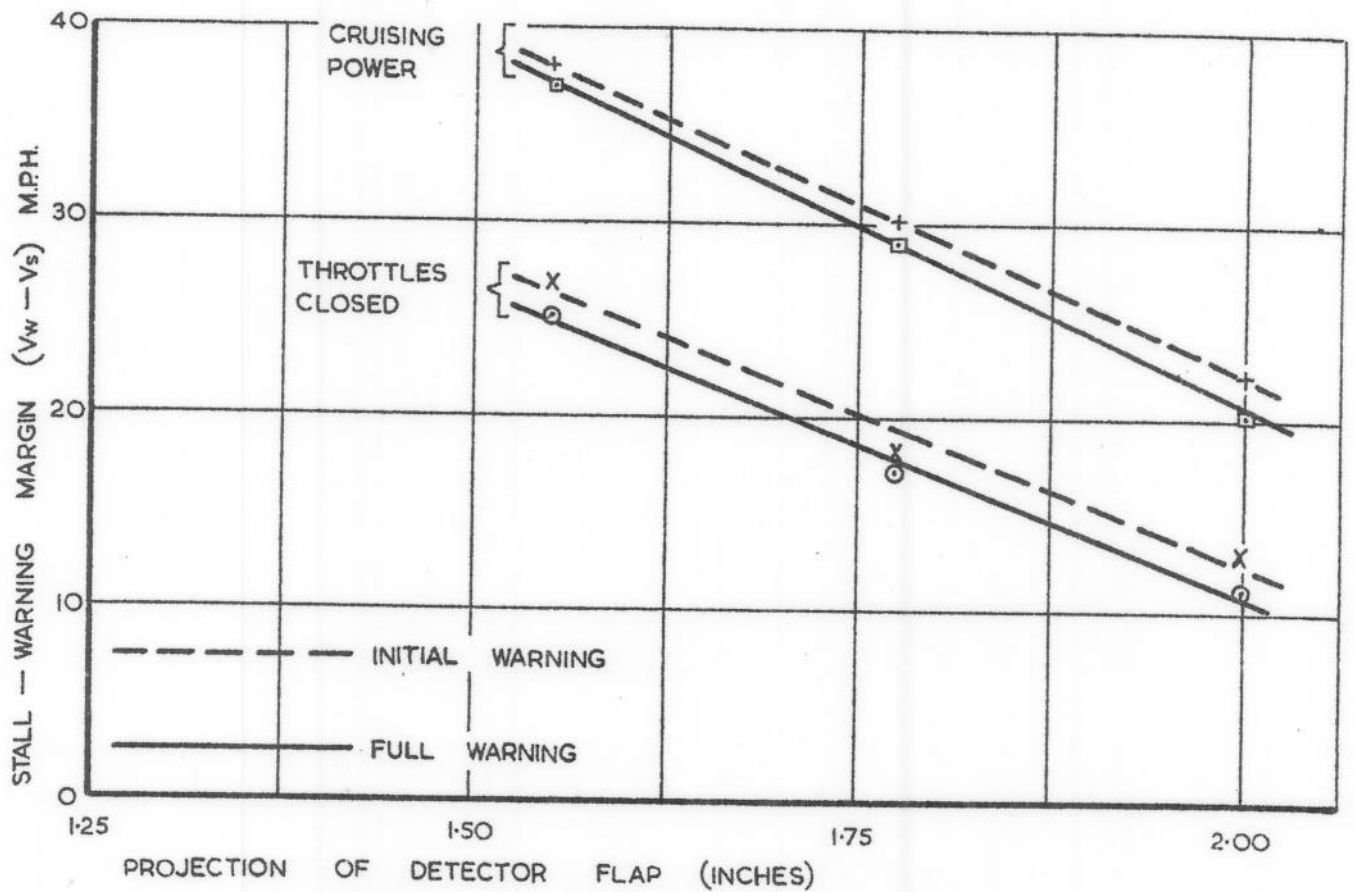

(a) LANDING FLAPS UP

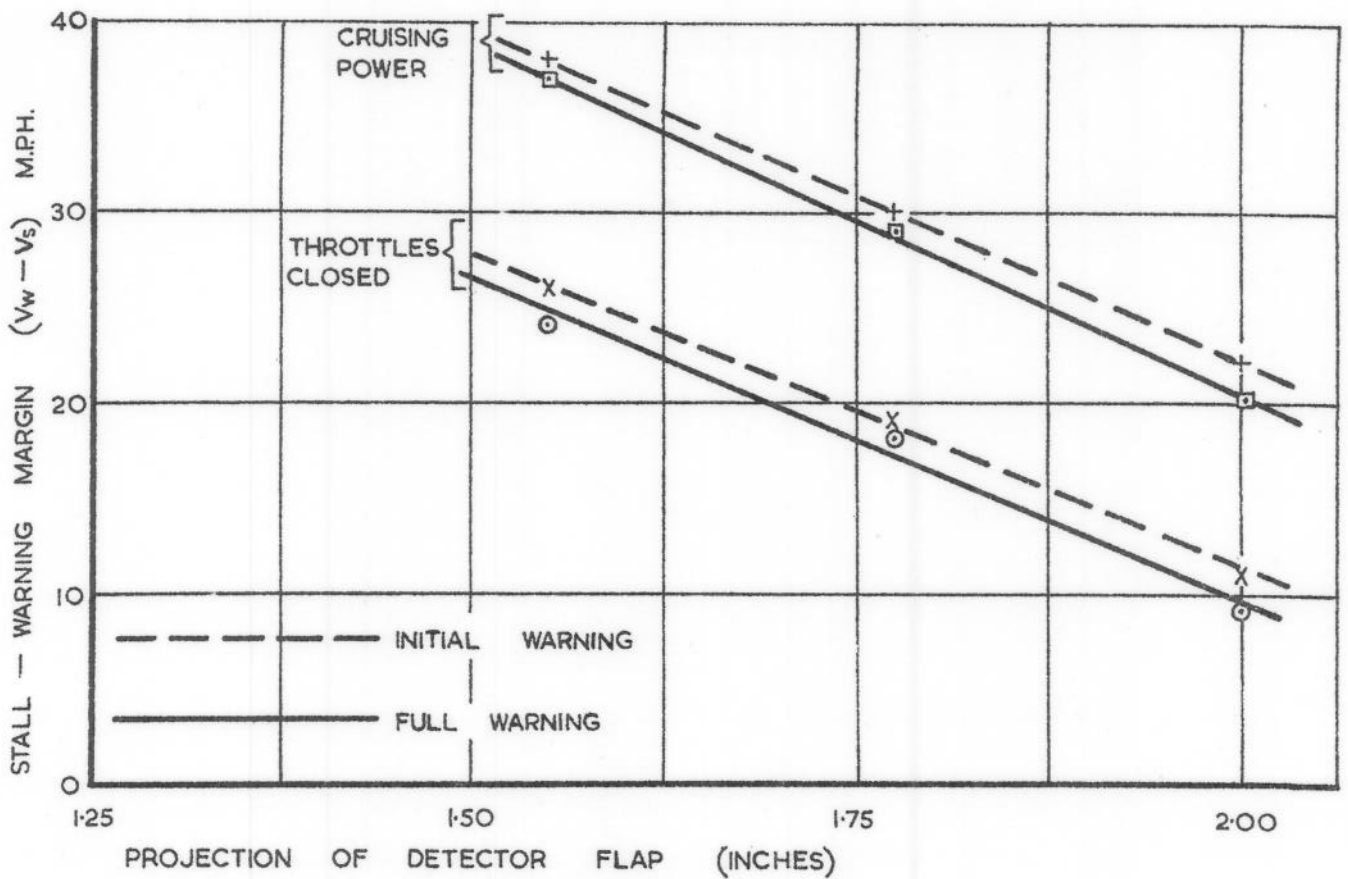

(b) LANDING FLAPS 60° DOWN

EFFECT OF LENGTH OF 30° BENT DETECTOR FLAP ON STALL - WARNING MARGIN — "ANSON"  
 (MICRO-SWITCH POSITION = O, I.E. AT DATUM POINT)



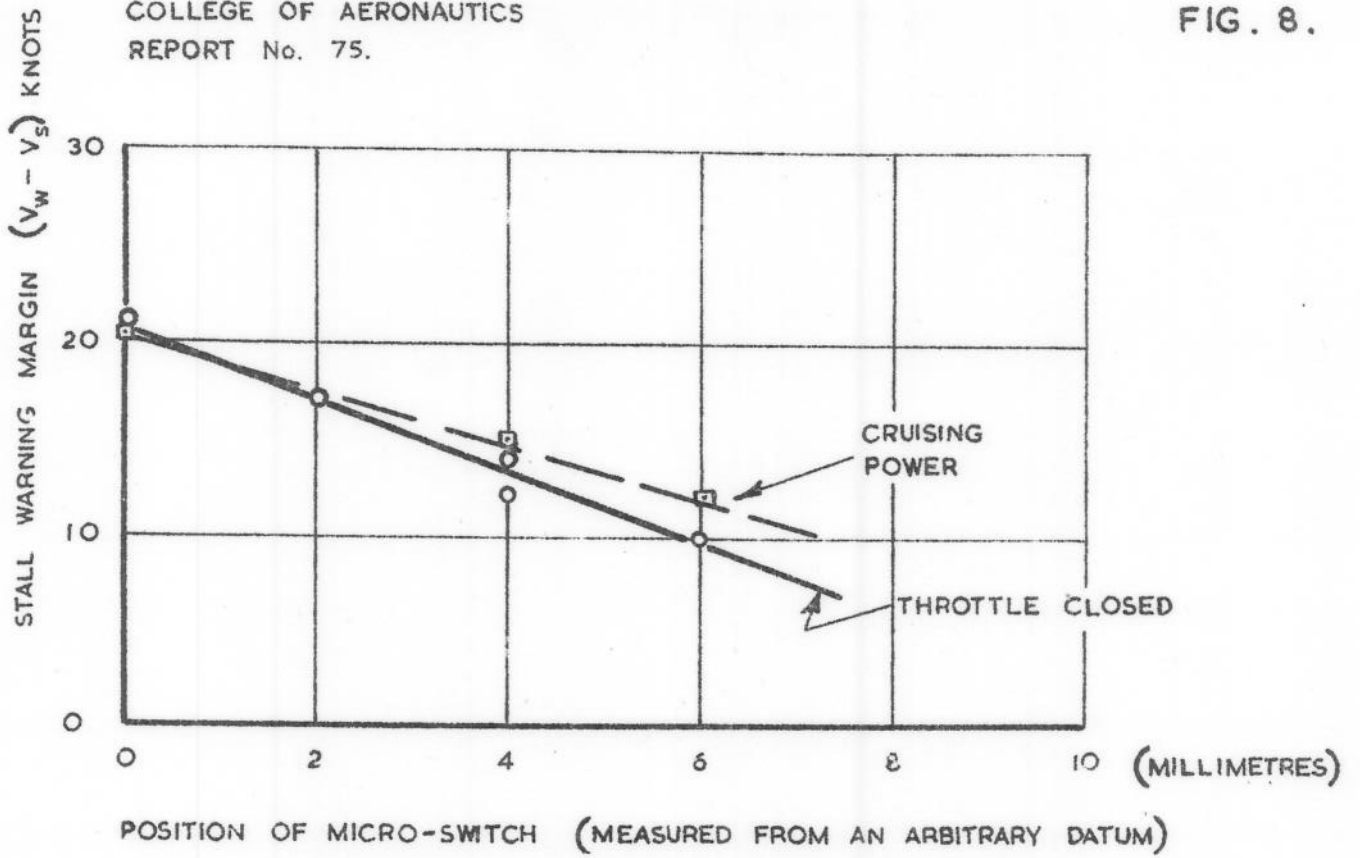

(a) LANDING FLAPS CLOSED

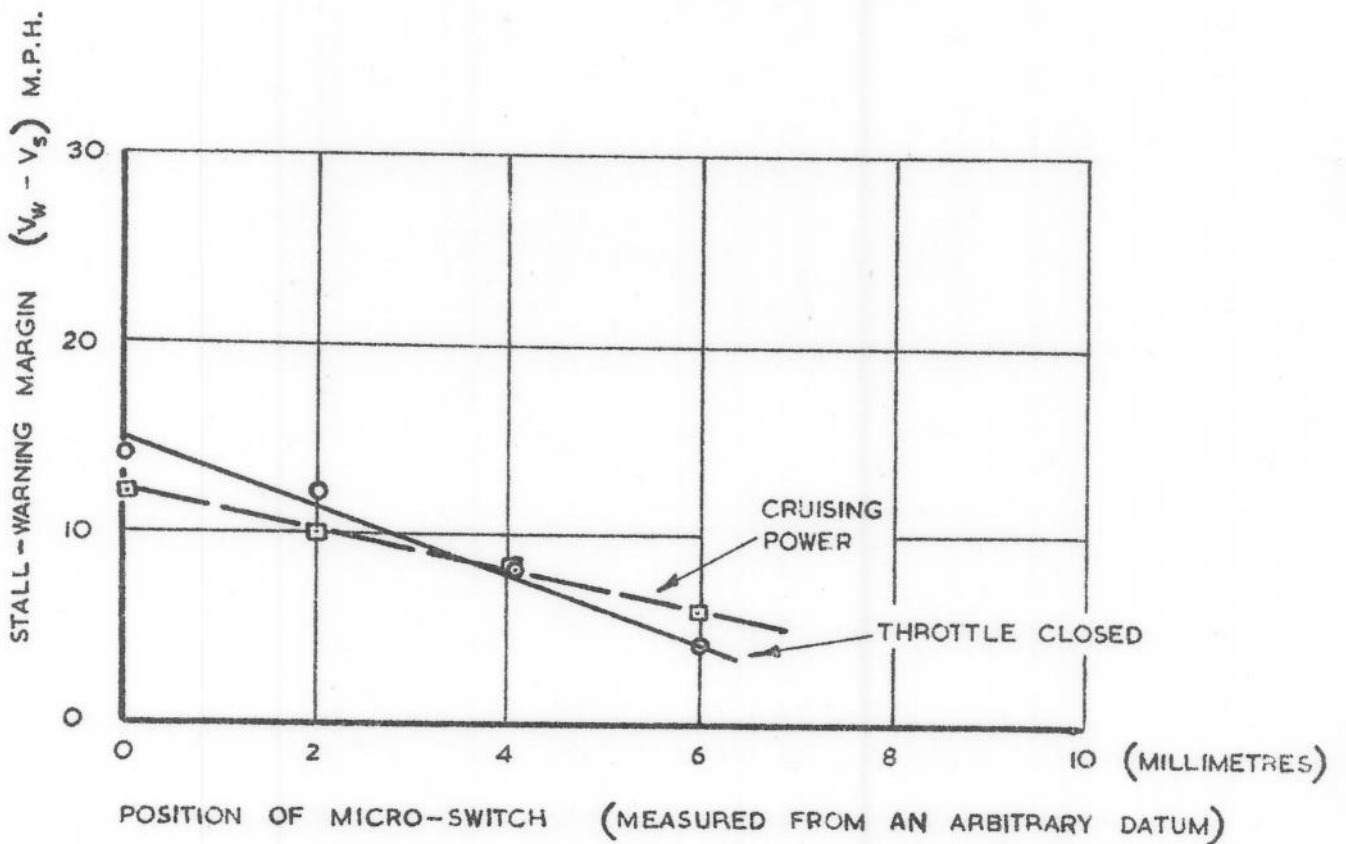

(b) LANDING FLAPS FULLY DOWN

EFFECT OF MICRO-SWITCH ADJUSTMENT ON  
STALL WARNING MARGINS - "PROVOST"  
(PROJECTION OF STALL DETECTOR =  $1\frac{7}{16}$ " )

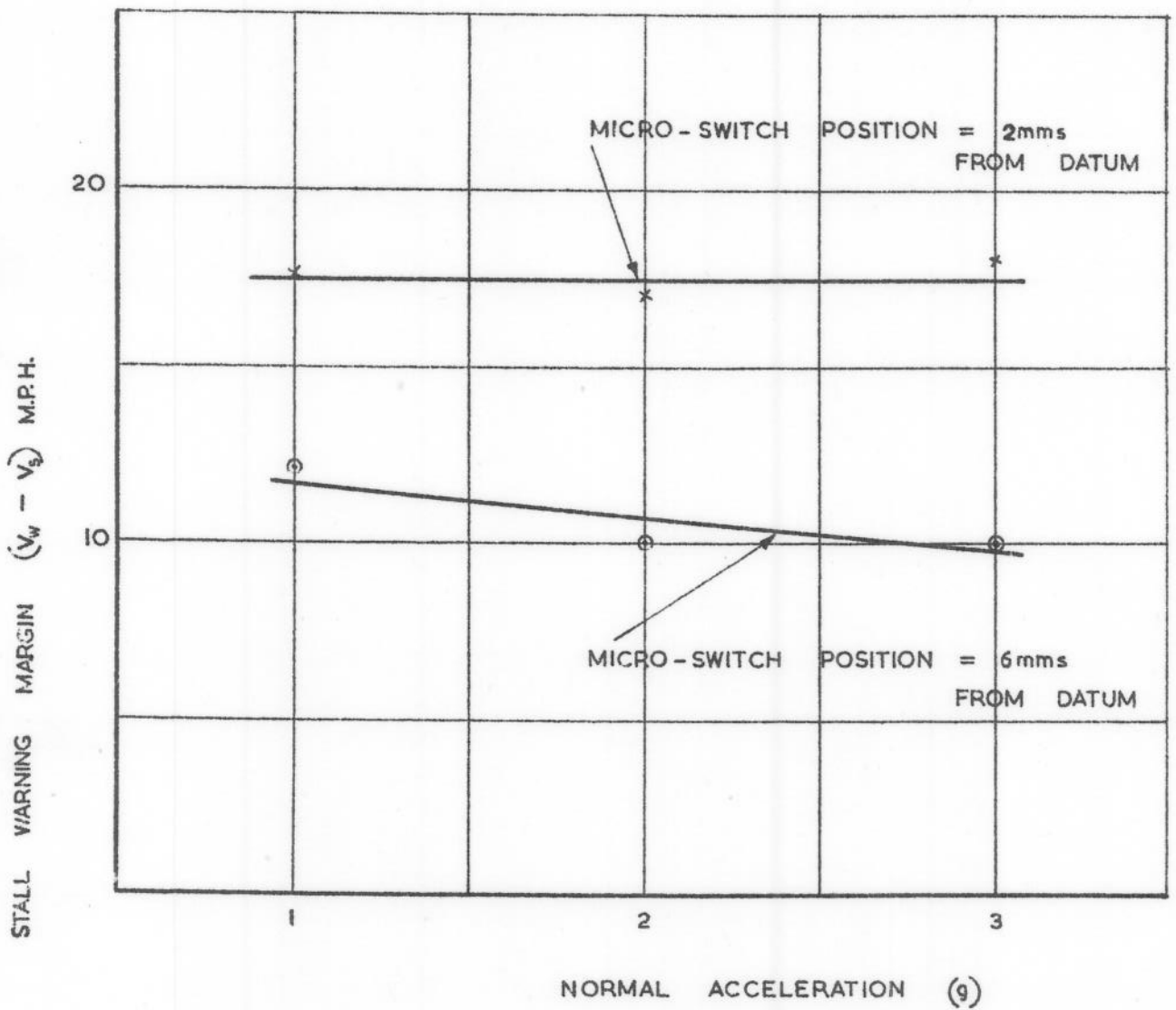

EFFECT OF NORMAL ACCELERATION  
ON STALL - WARNING MARGIN  
PERCIVAL "PROVOST"  
(FLAPS CLOSED)

(STALLS WERE CARRIED OUT AT CRUISING POWER  
IN STEADY FLIGHT AND IN STEEP TURNS  
AT STEADY "g")