

### IAC-10.A1.5.3

## CASS•E : CRANFIELD ASTROBIOLOGICAL STRATOSPHERIC SAMPLING EXPERIMENT

**L. Naicker**

Cranfield University, United Kingdom, lolan.naicker@physics.org

V.V. Grama, C.M. Juanes-Vallejo, I. Katramados, C. Rato, C. Rix, E. Sanchez, D. Cullen\*

CASS•E is a life detection experiment that aims to be capable of collecting microorganisms in Earth's Stratosphere. The experiment will be launched on a stratospheric balloon in collaboration with Eurolaunch through the BEXUS (Balloon-borne EXperiments for University Students) program from Esrange Sweden in October 2010. It essentially consists of a pump which draws air from the Stratosphere through a collection filter mechanism. Due to the low number density of microbes in the Stratosphere compared to the known levels of contamination at ground level, the experiment incorporated Planetary Protection and Contamination Control (PP&CC) protocols in its design and construction in order to confirm that any microbes detected are truly Stratospheric in origin. Space qualified cleaning and sterilisation techniques were employed throughout Assembly Integration and Testing (AIT) as well as bio-barriers which were designed to open only in the stratosphere and so prevent recontamination of the instrument after sterilisation. The material presented here covers the design and AIT of CASS•E.

### I. Introduction

The Earth's Stratosphere is an extreme environment with near vacuum pressure, high levels of ultraviolet radiation and temperatures as low as  $-90^{\circ}\text{C}$ <sup>1</sup>. The study of life in extreme environments on Earth is furthering understanding for the possibility of life elsewhere in the Universe<sup>2</sup>.

Historically, balloon experiments to detect life in the Stratosphere have not fully addressed the issue of ground contamination that may occur both before and after landing of Stratospheric balloon platforms used, in accordance with PP&CC protocols developed for space missions<sup>3,4,5,6</sup>. The concern is that ground levels of microbes will dominate over levels expected in the Stratosphere making detection and origin determination difficult.

PP&CC protocols have therefore been implemented. These involve the use of cleaning and sterilisation techniques to reduce bio-burden to acceptable levels. These were then followed by the verification of sterility levels using standard microbiological assays as well as the implementation of methods to prevent recontamination of the cleaned and sterilised instrument during AIT<sup>7</sup>.

Besides the implementation of these protocols which ensure no contamination occurs to the critical areas that collect microbes, the experiment was designed to function at the low temperatures and pressures expected during the flight and sustain the forces expected during landing.

The mission is guided by category IVb COSPAR (Committee on Space Research)<sup>8</sup> requirements.

The overall aims of CASS•E can be summarised as follows:

1. To design, build and fly an experiment for use on a Stratospheric balloon platform that is capable of collecting microorganisms in the Earth's Stratosphere.
2. To ensure, through the implementation and assessment of appropriate PP&CC protocols, that microorganisms collected are truly Stratospheric rather than contamination introduced during AIT, ground handling, launch, flight and recovery.

### II. Experiment Overview

The experiment, mounted to the gondola of a Stratospheric balloon, takes approximately 1 hour to reach an altitude of between 25 to 30 km<sup>1</sup>. It floats at this altitude for approximately 4 hours, after which the tether holding the gondola to the balloon is severed. The gondola then falls back to ground using a parachute.

In order to collect Stratospheric microorganisms CASS•E will draw a volume of Stratospheric atmosphere through a collection filter. The flow will be achieved using a vacuum pump once the BEXUS balloon reaches the Stratosphere.

Due to the flow rates achievable with pumps compatible with the size and mass requirements of the BEXUS platform, and the expected number densities of microbes in the Stratosphere<sup>3,4</sup> it is difficult for any Stratospheric microorganisms to be collected. The intention is for scientifically rigorous collection of Stratospheric organisms to occur in a future larger ver-

---

\* Cranfield Health, Cranfield University, United Kingdom, d.cullen@cranfield.ac.uk

sion of the experiment, which will benefit from the protocols and design proven by the CASS•E experiment on BEXUS.

The approach to implement PP&CC strategies has been to use protocols already established within the planetary exploration community. This includes bio-burden reduction by Dry Heat Microbial Reduction (DHMR) and maintenance of cleanliness using bio-barriers. The bio-barrier design has been based upon one of the approaches investigated for the robotic arm on the NASA Phoenix Lander<sup>9</sup>, where the bio-barrier was covered using Tyvek, released by a burn wire and retracted via tension springs.

The total weight of the experiment is 25 kg and it occupies a volume of 675 x 347 x 337mm (792mm in length with inlet bio barrier).

### III. Experiment Configuration

The experiment employs a volumetric filtration technique to sample Stratospheric air. Air is drawn through a 0.2µm mixed cellulose membrane filter via a vacuum diaphragm pump. The experiment is divided into two zones viz., the sterile or ultraclean zone and the non-sterile zone. The Ultra Clean Zone (UCZ) consists of components that will be in direct contact with the sampled Stratospheric air. The bio-barriers, filters, tubing, valves and accessories are within this zone. The components in the sterile zone have to comply with rigorous cleaning and sterilisation procedures<sup>10,11</sup>.

The process layout of the experiment is shown in Figure 1. The experiment consists of two BOXER® 7502 diaphragm pumps for redundancy. Diaphragm vacuum pumps are positive displacement pumps and have the advantage of introducing virtually no contamination into the fluid line. The inlet lines of the pumps are cross-linked to achieve a higher redundancy. The risk of failure of solenoid valve or filter is minimised in the design by incorporating two collection

lines. Each projecting inlet line is protected from external contamination by a separate bio-barrier. The projecting inlet lines are connected to a collection filter. A second barrier to external contamination is provided by a normally closed 100P2NC12-06S Bio-Chem Fluidics™ solenoid pinch valve mounted on each inlet line before the collection filter. The collection filters are connected to barrier filters which prevent back contamination from the pump. Each pump inlet line is connected to the barrier filter via a quick release coupling. The valves, filters and tubing are housed in a sealed aluminium box.

The pressure difference in the piping with respect to the ambient pressure is neutralized during the ascent phase using a check valve and during the descent phase using a solenoid pinch valve. The pressure difference occurring during the ascent and descent phase in the UCZ is neutralized by using a gas permeable Tyvek®1073B™ cover as shown in Figure 2.

A polypropylene sheet, heat-sealed on to the Tyvek® cover, acts as a transparent window. Silicone tubing was selected as it remains flexible at the expected low temperatures. Silicone o-rings seal different regions of the UCZ and bio-barriers.

The entire experiment is covered with Arma-chek S+ insulation panels on the outside to maintain a higher temperature relative to the ambient temperature in the Stratosphere.

The experiment is mounted into the gondola of the BEXUS balloon platform. All sides of the gondola are covered with canvas<sup>1</sup>. A small cut-out of 320mm x 200mm on the canvas cover is made in front of the experiment for the projecting inlet lines. The experiment rests on four compact wire rope springs which provide low shock absorption and good vibration damping from the vibrations experienced during the transport phase after landing.

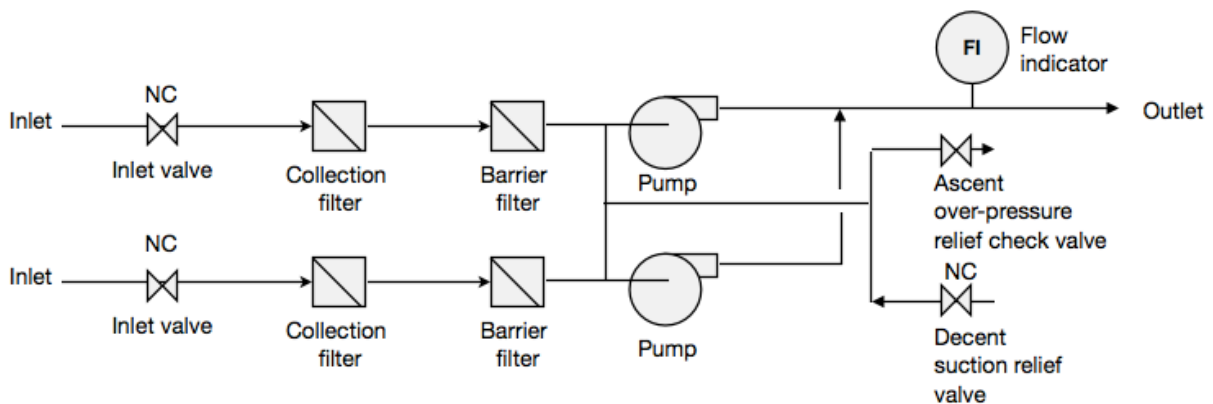

Fig 1: Layout of the CASS•E experiment (NC : Normally Closed)

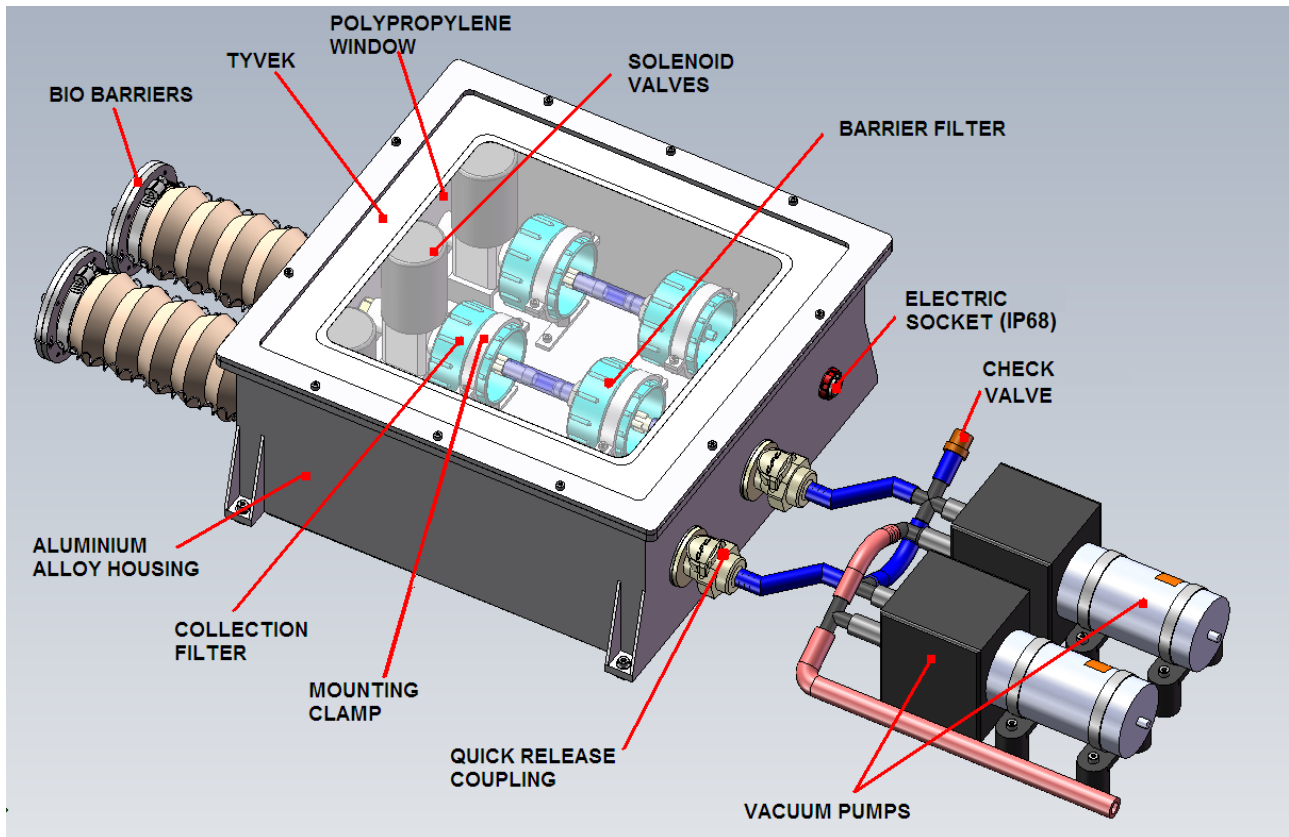

Fig 2: CASS•E Ultra Clean Zone (UCZ) with pumps and bio-barriers attached.

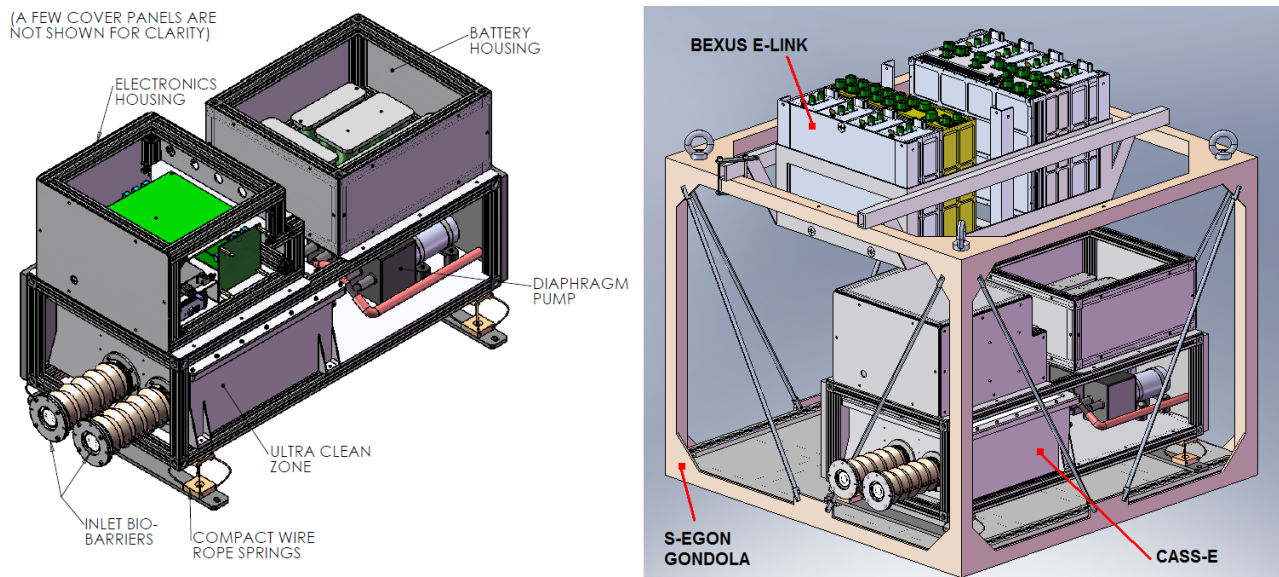

Fig 3: CASS•E assembly (left) & CASS•E in 'S-Egon'<sup>1</sup> gondola with communications 'E-Link'<sup>1</sup> system (right).

A flow sensor was constructed consisting of a Light Emitting Diode, emitting light continuously through the in-line impeller shown in Figure 4, connected to the outlet tubing. The impeller spins due to the air flow from the discharge ports of the diaphragm pumps, and in so doing it blocks light intermittently to a photodiode. This photodiode passes a fluctuating voltage signal to the electronics board indicating impeller rotation and therefore flow.



Fig 4: In-line flow indicator.

#### IV. Bio-Barrier Design

The inlet bio-barriers are the only component of CASS•E that are not Commercial Off The Shelf (COTS). For this reason, they had to be designed and tested thoroughly for proper functioning. Each of the two inlet tubing projecting out of the UCZ are covered by a bio-barrier. This provides redundancy, ensuring that the experiment does not fail to meet its objectives due to the failure of one bio-barrier. The inlet bio-barriers are an extension of the UCZ. They have two main functions:-

1. To prevent contamination of the projecting inlet tubing.
2. To provide the UCZ with controlled access to stratospheric air.

The bio-barrier front covers are made of Tyvek®, which helps in neutralising the pressure difference in the lines. An Igus® T500 type linear bearing is used with a clearance fit onto a stainless steel protection pipe. The T500 bearing has an operational temperature range of -100°C to +135°C and so does not require any thermal insulation or active heating. Due to some difficulties in sourcing medical grade silicone bellows, a sterilised polyethylene sheet was manufactured to cover the inlet mechanism. The bellows are sealed using stainless steel vacuum hose clamps and o-rings. A burn wire (set of three 5 Ω resistors in series) is sealed inside two Tyvek® discs and mounted in front of the inlet piping. Two extension springs provide a pre-tension which makes the Tyvek® disc rest on the end of the protection pipes. All flanges are made SS304 stainless steel.

The outer flange is restricted from slipping off the protection pipes by using a circlip and retraction springs. Tyvek® used here is ruptured with the help of the burn wire to allow access to the air at Stratospheric altitude. A set of 8.7x46.8 mm tension springs are used retract the bio-barrier after the Tyvek® has been ruptured. This part is protected with a temporary “remove before flight” cover to prevent damage during handling and transport.

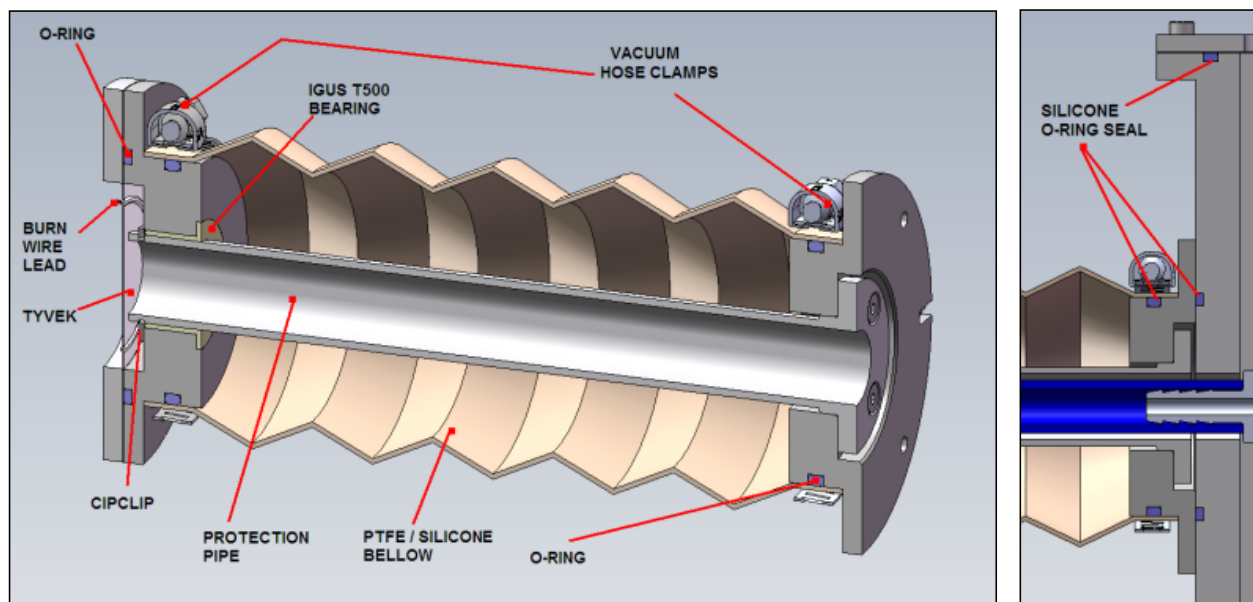

Fig 5: Longitudinal cut through the bio-barrier.

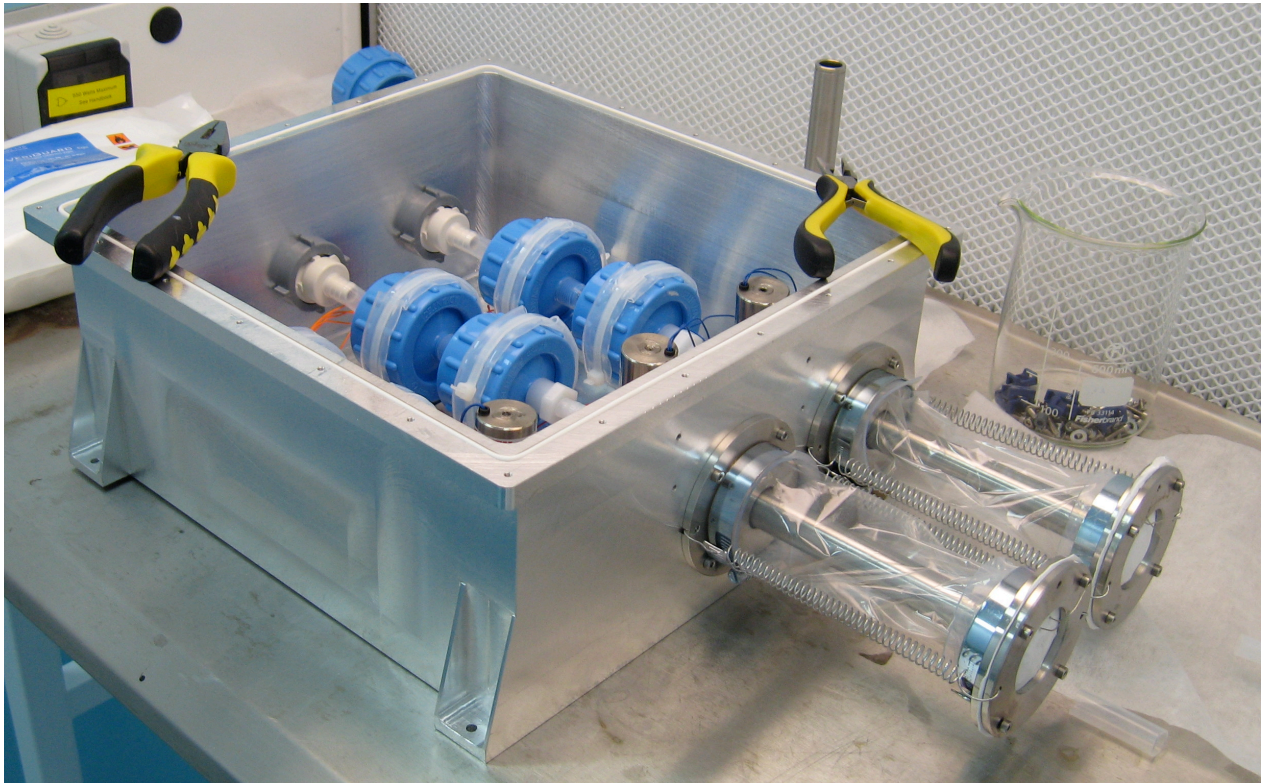

Fig 6: Assembled UCZ (excluding cover sheet)

#### V. PP&CC

The UCZ is not opened until after the BEXUS balloon has ascended to the Stratosphere. The flow-path of the sampled air, including the tubing and the collection filters is re-sealed prior to the descent phase of the balloon by closing the inlet valves. This protects the collected sample from contamination during landing and transportation, from the landing site in Sweden to Cranfield University UK.

The design of the bio-barrier aims to minimise the risk of contamination after bio-barrier opening by pulling the opened bio-barrier back and away from the collection tubes. The tubing protrudes 120 mm from the edge of the gondola. Ideally, longer tubes would be preferred to reduce the risk of contamination from the gondola itself. Previous balloon experiments have used tubing that protrudes as much as 2 m from the edge of the gondola<sup>12</sup> but this is not possible on the BEXUS balloon platform.

For the CASS•E experiment it was important that the presence of both viable and dead microorganisms inside the UCZ be minimised as the detection methods used on the filters post-flight may not discriminate between the two. This minimisation was achieved by cleaning and sterilisation. Cleaning is a physical or chemical process that reduces bio-burden but does not eliminate it whereas sterilisation is a process that destroys or eliminates all forms of life.

The cleaning method of choice for CASS•E was immersion in 70% Iso Propyl Alcohol (IPA) with sonication, which both reduces bio-burden through the physical process of immersion and sonication and acts as a sterilisation agent. Where components are incompatible with IPA immersion, wiping was used as an alternative technique. In addition to this all components within the UCZ were cleaned by IPA immersion/wiping prior to the sealing of the UCZ and Dry Heat Microbial Reduction (DHMR).

Design choices were made such that all components within the UCZ were compatible with IPA immersion/wiping. Similarly to cleaning, there are a number of bioburden reduction techniques available, but DHMR is the only technique that has been qualified by NASA. DHMR involves heating of the items under controlled humidity ( $< 1.2 \text{ g/m}^3$  water) for a given length of time. Since there is free exchange of gas between the UCZ and the atmosphere (through the Tyvek® cover sheet), the surfaces inside the UCZ can be considered as free or mated and the time temperature regime required for a  $10^4$  reduction of bioburden is  $110^\circ\text{C}$  for 32 hours. In order to ensure the efficiency of the sterilisation procedure temperature and humidity profiles were recorded during the sterilisation.

In order to ensure the minimum possible level of contamination and to maintain cleanliness post sterilisation, it was essential that the AIT process be conducted in a clean room. A further level of protection

was introduced through the use of a laminar flow cabinet within the cleanroom for handling UCZ components. All handling and integration of UCZ components was carried out inside an ISO8 (Class 100 000) clean room situated at Cranfield University. It was necessary to verify that the cleaning and decontamination procedures put in place had been successful and there are a number of methods by which this could be achieved. The standard method used in the space exploration community is swabbing and culturing, where surfaces are swabbed and the cells collected on the swabs are extracted and then cultured following a standard protocol<sup>13</sup>. The drawback of this method is the time involved in culturing. The chosen method is an Adenosine Tri-Phosphate (ATP) assay. This method is rapid and relatively easy to carry out. The main drawback of using ATP detection is that it is not ideal for the detection of spores, since spores are dormant and therefore may not have detectable levels of ATP present.

To better understand contamination pathways, 0.2 µm diameter fluorescent beads will be used as easily detectable proxies of microorganisms. To differentiate between paths of contamination, different coloured beads will be sprayed onto the experiment prior to launch to deliberately contaminate different regions. The post-flight detection of fluorescent beads on the filter will allow for an estimate of contamination levels and an identification of their source<sup>14</sup>.

In order to build redundancy into the system, as well as offer the potential of two semi-independent measurements, a two channel system was included comprising two pumps and filter units, with an additional third 'control' channel (consisting of a valve, tubing and filter but not connected to the pump), which will not be exposed to the Stratosphere and so act as a 'flight control'.

A shipping control has also been included (the flight spare) to assess whether contamination has been introduced during shipping, and a storage control has also been prepared at Cranfield University to check for contamination during clean room handling.

## VI. Testing

As the experiment will be exposed to very low temperatures and pressures, components rated for those conditions should ideally be chosen. In many cases this was not within the budget of the experiment. Each component in the design was therefore tested at low temperature and pressure to prove that it could function as required or to determine the limits of its operational envelope, beyond that which it is rated to deliver.

The facilities used at Cranfield University included a -20°C freezer for preliminary testing and selection of components, a -80°C freezer for extreme environment proving and a mini vacuum chamber for testing of individual components.

The inlet bio-barrier mechanism was completely assembled and tested (Figure 6). A power of 12V and 0.8 A was supplied to the resistors to burn the Tyvek® discs and thereby breach the UCZ. The springs successfully retracted the setup. The experiment was repeated a number of times to gain confidence that procedure used to assemble the biobarrier produced a repeatable successful breach upon activation of the burn wire.

The pump diaphragms and internal valves were exchanged for silicone replacements to allow lower temperature operation of the pump and reduce the risk of rupture under low temperature. The pump was found to operate successfully at -10°C.

The in-line flow indicator used does not provide a measurement of flowrate. Ideally a mass flowmeter able to operate at low fluid density and temperatures is required. As this is beyond the budget of the project a calibration curve of pressure versus flowrate was generated as an alternative. Knowledge of the atmospheric pressure, using the on-board pressure indicator, at particular altitudes will allow for an estimate of the flowrate through the filters given this curve. The curve was generated by measuring the volume of gas displaced by the pump over a particular time period at different vacuum levels.

The validated flowrate per pump is approximately 32 l/min at ground conditions and the performance of the pump is seen to degrade at higher vacuum levels.

The Open University vacuum chamber was used to test the functionality of the fully assembled experiment under combined low temperature and low pressure simulation of the ascent and float phases. The experiment was enveloped within a liquid nitrogen cooled copper shroud. The simulated ascent (performed for the worst case scenario of no internal heating capability) showed that the lowest temperature the experiment is expected to reach is -10°C before full operation commences.

Testing within this chamber also confirmed the capability of the biobarrier burn mechanism, opening of the inlet valves, the cold start operation of the pumps and positive indication of flow via the flow indicator.

## VII. Conclusion

CASS•E has undergone AIT guided by space industry standard PP&CC protocols and category IVb CO-SPAR requirements.

The design is such that ground contamination is completely prevented prior to sampling, by breaching the bio-barrier only when the balloon reaches Stratospheric altitude. Further, the sterile zone is re-sealed at the Stratospheric altitude using a fail-close valve, preventing contamination during descent and landing. Due to time and budget constraints, the experiment had to be designed with COTS components. The design

presented is therefore not optimised with respect to mass or volume.

Components have been vacuum and thermal tested, both individually and in the fully integrated experiment, to confirm operational capability at the expected flight atmospheric conditions.

The experiment is fully constructed and ready for launch in October 2010.

### VIII. Acknowledgements

Professor David Cullen, Dr Peter Roberts, Dr Jenny Kingston and Mr Dave Pitts (Cranfield University), for their support and advice throughout the various review stages.

Dr Judith Pillinger (The Open University) for guidance concerning Planetary Protection and Contamination Control as well as Mr Winston Waller (Kent University) for his help on the electronics design.

Marjorie Allen, David Titmus, Tom O'Brien and Rita O'Brien of Cranfield University for their assistance in preparing the cleanroom and cleanroom equipment.

Cranfield University for providing lab and workshop facilities.

Manish Patel and Tim Ringrose at Open University for vacuum testing and DHMR.

Naomie Stanford-Jones at the Cranfield University Press Office for support with press releases.

Other members of staff and students at Cranfield University as well as other REXUS and BEXUS teams, for supporting us by providing advice, giving feedback, making suggestions and taking an interest in the CASS•E experiment.

The European Space Agency (ESA), the German Aerospace Centre (DLR), the Swedish National Space Board (SNSB), the Swedish Space Corporation and Eurolaunch for the opportunity to fly CASS•E as part of the REXUS BEXUS program

Finally a special thanks to our industrial sponsors for donating components and providing technical support: U-blox, Alphamicro, Westfield Medical, Aigis mechnronics, Taoglas, Uno international, DuPont, Lantronix, Microchip, Maxim, Armacell, ITT, Biocontrol, Guardline and Igus.

### REFERENCES

<sup>1</sup> O. Persson et al., 2009, BEXUS User Manual, Euro-launch Document ID: RXBX-Bexus user manual-v6

<sup>2</sup> Imshenetsky, A.A., Lysenko, S.V., Kazakov, G.A., 1978, "Upper boundary of the biosphere", Applied and Environmental Microbiology, 35(1): 1-5

<sup>3</sup> Narlikar, J.V., Lloyd, D., Wickramasinghe, N.C., Harris, M.J., Turner, M.P., Al-Mufti, S., Wallis M.K., Wainwright, M., Rajaratnam, P., Shavaji, S., Reddy, G.S.N., Ramadurai, S., Hoyle, F., 2003, "A Balloon experiment to detect microorganisms in the Stratosphere", *Astrophysics and Space Science*, 285: 555-562

<sup>4</sup> Griffin, D., 2004, "Terrestrial microorganisms at an altitude of 20,000 m in Earth's atmosphere", *Aerobiologica*, 20: 135-140

<sup>5</sup> Martin Rudolph, M., Holl, G., Fittock, M., Siegl M., Urbar, J., 2009, SED version 7.2, Stratospheric Census

<sup>6</sup> Moissl, C., Osman, S., La Duc, M.T., Dekas, A., Brodie, E., DeSantis, T., Venkateswaran, K., 2007, "Molecular bacterial community analysis of clean rooms where spacecraft are assembled", *Microbial Ecology*, 1-13.

<sup>7</sup> ESA, 2008, Doc no. EXM-MS-TNO-AI-0128, issue 01

<sup>8</sup> Pillinger, J., Pillinger, C.T., Sancisi-Frey, S., Spry, J.A., 2006, "The microbiology of spacecraft hardware: Lessons learned from the planetary protection activities on the Beagle 2 spacecraft", *Research in Microbiology*, 157: (19-24)

<sup>9</sup> Salinas, Y., Zimmerman, W., Kulczycki, E., Chung, S., Cholakian, T., 2006, "Bio-barriers: Preventing forward contamination and protecting planetary astrobiology instruments", IEEEAC paper no 1216, version 1.

<sup>10</sup> Planetary protection provisions for robotic extraterrestrial missions, 2001, NASA Procedural Requirements 8020.12C, National Aeronautics and Space Administration

<sup>11</sup> Exomars planetary protection training program, 2009, EX-MS-TNO-AI-0128, ThalesAlenia Space

<sup>12</sup> Wainwright, M., Wickramasinghe, N. C., Narlikar, J. V., Rajaratnam, P., 2003, "Microorganisms cultured from stratospheric air samples obtained at 41 km", *FEMS Microbiology Letters*, 218, 161-165

<sup>13</sup> NASA standard procedures for the microbial examination of space-hardware, 1980, NASA, procedures and Guidelines (NPG) 5430.1B, NASA headquarters Washington

<sup>14</sup> Monaghan, E., 2009, "Protocol development for the assessment of bioburden levels of small space-instrument components for life detection during planetary exploration", MSc Thesis, School of Engineering, Cranfield University.

# CASS•E: Cranfield astrobiological stratospheric sampling experiment

Naicker, L.

2010-12-31T00:00:00Z

---

L. Naicker, V.V. Grama, C.M. Juanes-Vallejo, I. Katramados, C. Rato, C. Rix, E. Sanchez, D. Cullen. CASS•E: Cranfield astrobiological stratospheric sampling experiment. 61st International Astronautical Congress, Prague, CZ. 27th September - 1 October 2010.

<http://dspace.lib.cranfield.ac.uk/handle/1826/7034>

*Downloaded from CERES Research Repository, Cranfield University*