

## Development of an Extended Product Lifecycle Management through Service Oriented Architecture.

J. Cassina, A. Cannata, M. Taisch

Politecnico di Milano

Piazza Leonardo da Vinci 32, 20133 Milano

{ jacopo.cassina; alessandro.cannata; marco.taisch } @polimi.it

### Abstract

The aim of this work is to define new business opportunities through the concept of Extended Product Lifecycle Management (ExtPLM), analysing its potential implementation within a Service Oriented Architecture. ExtPLM merges the concepts of Extended Product, Avatar and PLM. It aims at allowing a closer interaction between enterprises and their customers, who are integrated in all phases of the life cycle, creating new technical functionalities and services, improving both the practical (e.g. improving usage, improving safety, allowing predictive maintenance) and the emotional side (e.g. extreme customization) of the product.

### Keywords:

PLM, Extended Product, Service Oriented Architecture

## 1 INTRODUCTION

Nowadays, enterprises are ever more stressed and subjected to high market requests. Customers are more and more sophisticated in terms of products quality and related services. Thus, the "product" and its related management are becoming unavoidable key-aspect for the creation of a "product centric" or "product-driven" approach.

This work aims at defining new business opportunities through the combination of the concepts of PLM, Product Extension and Avatar. Moreover it will be investigated the possibility of merging these ideas with the Service Oriented Architecture approach.

The target is to allow a closer interaction between enterprises and their customers, who are integrated in all phases of the life cycle, creating new technical functionalities and services, improving both the practical (e.g. usage, safety, allowing predictive maintenance) and the emotional side (e.g. extreme customization) of the product.

This paper deals with two completely different meanings of the same word: service. First of all, it will refer to the business meaning of functionality or features required by customers. On the one hand the word "service" will refer to a software component that can encapsulate business logic. In order to avoid misunderstandings we will refer to this meaning adopting the expression web service (or the acronym WS, and the known name of Service oriented architecture - SOA) instead we will use the term service by itself to refer to the other meaning.

This paper will first of all explain the concept of Extended Product Lifecycle Management, that has been developed

starting from the concepts of PLM, Extended Product and Avatar.

Then will be investigated the possibilities achieved by the adoption of Service oriented architecture (SOA) that uses loosely coupled web services (WS) to encapsulate and deploy business processes and products.

For this area, the results of an European Project called Socrates will be analyzed, and the impacts of two main technologies such as embedded systems and wireless communication will be considered.

The final aim is to propose a framework where products provided with enough intelligence can autonomously interact with other devices/humans within and outside the industrial plants through its overall lifecycle. Since each business process (production, logistics, maintenance, etc.) can be represented as a set of WS, such aspects as services or functionality can be naturally included and controlled in the framework. Finally, thanks to SOA paradigm, communication among different systems becomes naturally supported, being the base of the Extended PLM where products can take advantage of pervasive information more and more available in the coming Internet of Things.

## 2 PRODUCT LIFECYCLE MANAGEMENT:

The term Product Life-Cycle Management (PLM) defines the integration of different kind of activities, from the technical, organisational and managerial point of view, which are performed by engineering staff along the entire life-cycle of industrial products. This cycle covers the concept, the development and the design of the product, together with the manufacturing process planning, the

factory and supply-chain planning, till to the final disposal/recycling of the product itself. All these activities are strongly based and supported by engineering and production management information systems. Generally, PLM is an integrated approach for the management of product data along the product lifecycle ("from the cradle to the grave"). As such, it entails [1]:

- a strategic management perspective, wherein the product is the enterprise value creator,
- the application of a collaborative approach to better use the enterprise competences distributed amongst diverse business actors,
- the adoption of plenty of ICTs in order to practically establish a coordinated, integrated and access-safe product information management environment in the extended context.

Then, PLM deals with the management of all the product data that are created, stored and managed along the lifecycle of a product, from its design to end of life. In such a way, it is possible to say that PLM is assuming a "holistic" role: according to Stark [2], "PLM brings together products, services, structures, activities, processes, people, skills, application systems, data, information, knowledge, techniques, practices, skills and standards".

Listening to the enterprise requests, several vendors, coming from different areas interested into the product and production management, are creating a PLM software market. Nevertheless, PLM is not primary an IT problem, but at first, is a strategic business orientation of the enterprise. From a strategic organisation point of view, the adoption of a "product centric" approach means a remodelling of all the relations established between the resources (people and equipment) involved into the relevant business processes oriented to a "product" lifecycle direction, with all that it concerns in terms of task allocations and measurement of the obtainable performances.

In literature there are many different lifecycle models.

The most common one presents three life cycle phases:

- Beginning of Life (**BoL**): when the product is in the hands of the manufacturer.
- Middle of Life (**MoL**): when the product is owned by the consumers.
- End of Life (**EoL**): when the product has finished its useful life and has to be dismissed.

### 3 THE EXTENDED PRODUCT

The explosion of information & communication technologies has created a new kind of concept, defined as Extended Product, where the product is more than a simple artefact, but it is a complex result of tangible and intangible components. The extension is usually related to the functionality or a new business process around the product. According to Jansson [3] and Hirsch [4] tangible extended product can be intelligent, highly customized, and user-friendly; an intangible product is mostly the business process itself.

### 4 THE AVATAR CONCEPT

The Avatar is a virtual representation of the product, a digital shadow that contains all the information and knowledge of it. The Avatar is always connected with the physical item allowing all the stakeholders easier and better communications with it.

The product-avatar that emerges is the sum of the physical product and an ICT shell of information, knowledge and intelligence.

According to McFarlane [5] and Hribernik [6], the product avatar is characterized by:

- possessing a unique identity,
- capability of communicating effectively with its environment,
- can create, access transfer and operate upon information about himself,
- deploys a language to display its features,
- is capable of participating in or making decisions relevant to his destiny.

### 5 DEFINITION OF EXTPLM

The Extended Product Lifecycle Management aims at creating new business opportunities through the combination of the previously explained concepts of PLM, Product Extension and Avatar [7] (Figure 1).

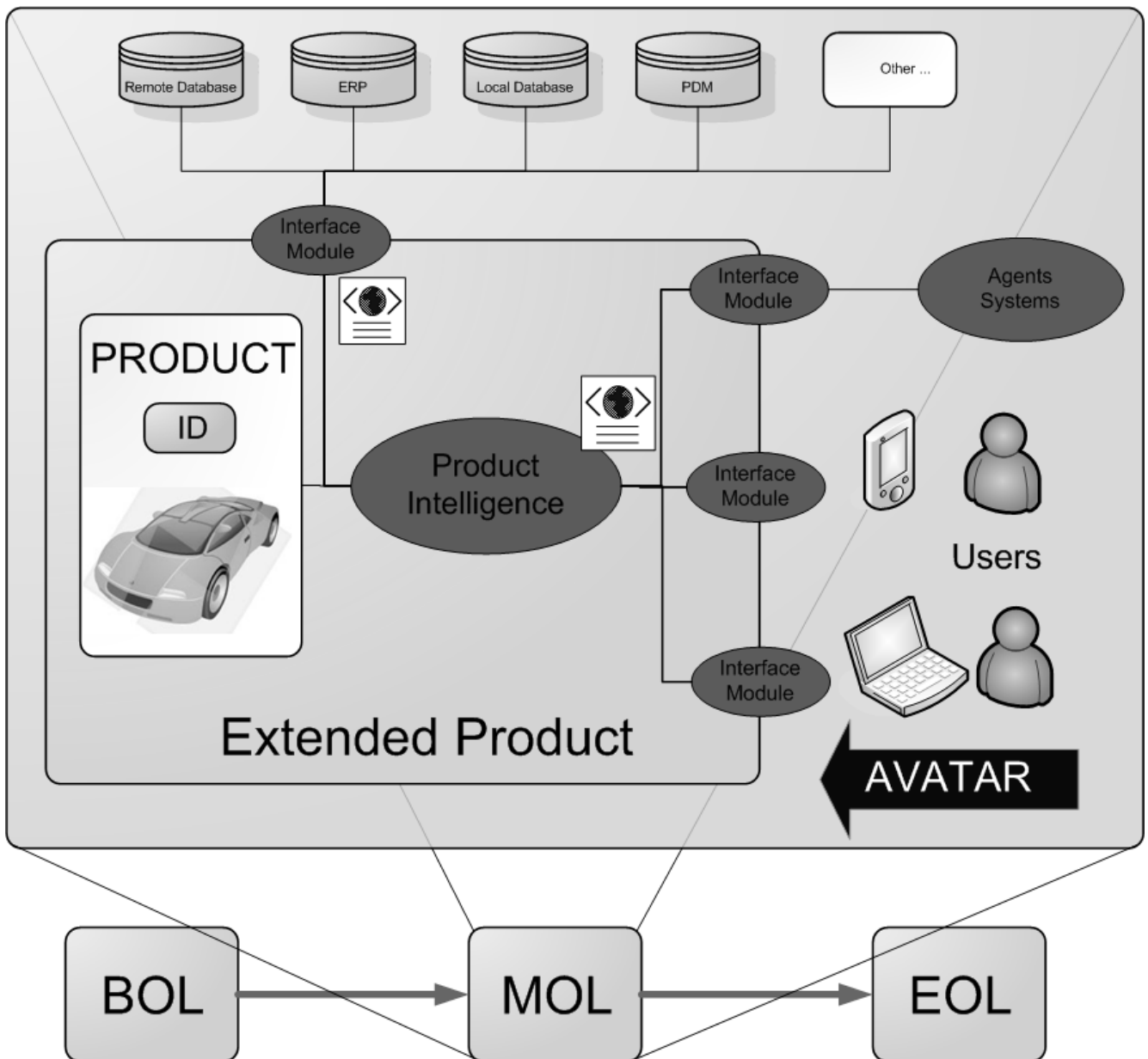

## ExtPLM

Figure 1: ExtPLM Schema [7]

It aims at allowing a closer interaction between enterprises and their customers, who are integrated in all phases of the life cycle, creating new technical functionalities and services, improving both the practical (e.g. improving usage, improving safety, allowing predictive maintenance) and the emotional side (e.g. extreme customization) of the product.

In the previous schema it is possible to see how the Product, recognized using its id, is extended through product intelligence and is interfaced to the user, who interacts with it as an avatar.

The ExtPLM aims at following this extended product through all its lifecycle phases, giving to the product end-user a set of services that will extend the usability and the utility of the product itself, improving the ownership experience. These services will also improve the market value of the product itself, and can be sold both to the customer (e.g. predictive maintenance) and to other companies (e.g. specific advertising).

Examples of applications could be a deep customization, predictive maintenance, customized manuals and FAQs (frequently asked questions), self adaptability to the user etc.

To define all the possibilities of ExtPLM, a Delphi study has been carried out with the efforts of experts from all over the world [8], analyzing all the answers and then the whole, a list of ExtPLM possibilities, within the different lifecycle phases, emerged. These are explained in the following.

During the BOL (Beginning Of Life), which is composed by the design, the manufacturing and the delivery phases, the customer will be able to define and redesign the product according to his needs and willing, changing the configuration as many times he wants, shaping the initial form of the avatar within his hands. During this first phase since the physical part still doesn't exist, the customer directly interacts with the virtual part of the avatar. For example, through a web site, he is able to modify the parameters of the product he is aiming for, verify the result on a virtual model and being informed about price

changes due to his decisions. Moreover the avatar will also give him specific suggestions on possible improvements and particular discounts. This will allow the buyer to tailor the product on his very own needs, opening the possibility of a mass customization. Furthermore, the information on the behaviour of the customer within a configurator and the data from the products already sold (e.g. failures reports, most common upgrades, etc.) will be used from the designers and the engineers to improve the design making better and more desirable products. Then, if the customer will order the production of the avatar he shaped, he will be allowed to follow its idea during the production, being able to modify his decisions about the specifications if he wants, being informed if there have been changes in the process or in the raw materials available. During this phase the buyer will also be able to change some product characteristics like for example the colour of the product, e.g. if a new one is proposed by the producer. He will be able to modify actively the price, selecting different quality, or modifying the delivery date, or using recycled or remanufactured parts. During this phase the customer will also be able to follow and to see how his product is "growing", being assembled. From the manufacturer point of view, the avatar will be ready to auto-negotiation processes within the shop floor, to optimize the usage of the resources, the machines and the manpower. The extended product will also be able to interact with the suppliers and the ERP, adding items to the list of products to purchase improving the management within the company itself. When the product has reached its final physical form, the buyer will also be able to modify the shipping while it is in process, modifying both the place and the time of the deliver

During the MOL (Middle Of Life) phase, the extended product, using the sensors on the physical side and the intelligence of the ICT side, will collect data during the usage. These will allow self diagnose, that will lead - for example - to predictive maintenance; moreover it will be able to understand the needs and the habits of its user, suggesting way of using it better, or being able to answer questions of the customer. All these will lead to a better interaction with the product. The end user, who is the owner of the data, will be able to share the collected data

with the producer, being paid or with other benefits for that, allowing this way a continuous re-design process that will lead to continuous improvements. Furthermore the user will be able to access, suggested by the product itself, manuals, FAQs, wikis and forums where he could share his experiences with other users, creating a virtual community. Finally the data will allow the extended product to be able to propose to his user services, upgrades or information and news that it considers interesting for him through an analysis of the behaviour.

The stored data will also improve the EOL (End Of Life), since it will be possible for the avatar to esteem the aging of its own components, suggesting these to reuse, remanufacture and recycle.

## 6 AN ARCHITECTURE FOR EXTPLM

As emerged in the previous sections, flexible information, knowledge management, communication and treatment are the basis to achieve an Extended Product Lifecycle Management. The ExtPLM concept requires that continuous changes and modifications could occur both from customer and company sides, highly flexible and reconfigurable information and manufacturing systems are needed to ace the new level of variability.

Within the PROMISE project, that dealt with Closed Loop Lifecycle Management [9], an architecture for managing products during their whole lifecycle has been proposed. This architecture, represented in figure 2, allows great flexibility and connectivity and can represent the basis for the ExtPLM.

Within the same project, it has been also developed a Product Data Knowledge Management Sistem Object Model (PDKM SOM), that has been then implemented using different tools (MySQL, MySAP-PLM) and an ontology [10].

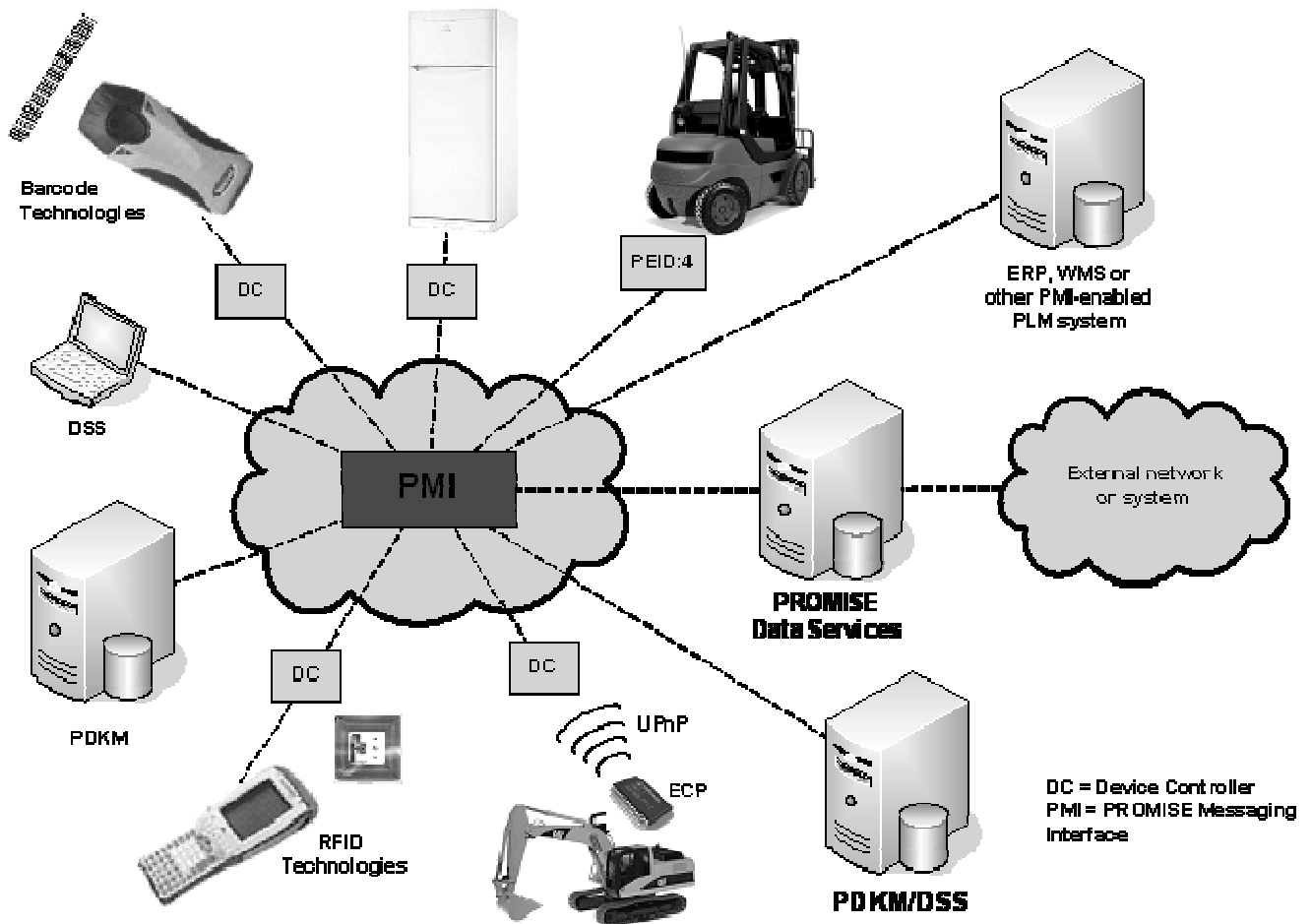

Figure 2: PROMISE Connectivity [10]

An improvement of this kind of architecture, using the same kind of data structure, can be achieved if it will be developed using the Service-oriented Architecture (SOA) as conceptual model for software organization.

## 7 SERVICE ORIENTED ARCHITECTURE

There are multiple definitions of SOA both in technological and business perspectives [11-12-13]. For the purpose of this document, the following will be used: "A *service-oriented architecture (SOA)* is a set of architectural tenets for building autonomous yet interoperable systems" [14].

SOA can be considered more an architecture philosophy than a technology or a standard since it represents a set of good principles for designing, open and interoperable software.

The proposed definition includes two keywords: *autonomous* and *interoperable*.

The principal characteristics setting apart *autonomous* systems are that:

- they are created independently of each other
- they provide self-contained functionality, i.e., their functionality would be useful even if it was not associated with any higher level systems.

*Interoperability* is favoured by:

- clearly abstracting the interface that a service exposes to its environment, from the implementation of that service;
- making this interface visible to others, together with policies and constraints for its use.

To achieve the ExtPLM vision through SOA, both high enterprise level and device level services have to be analyzed, defined and implemented.

At enterprise level SOA concepts have been studied in the last years [15-16], fewer works and literature can be found on the adoption of SOA at low level (e.g. for supporting interaction between products and industrial devices/machines or else). The interaction between product and "production systems" or customer in a seamless way through WS-orientation is not yet deeply studied and developed; only some paper can be found on the adoption of web ontology for supporting design and engineering activities, not for supporting PLM nor extended product or manufacturing activities [17]. In order to let the product become an agent that can autonomously interact with such heterogeneous entities, there is a strong need for a common language such as WS that need to be implemented on both sides: manufacturing devices and products (i.e.: for shop floor control applications).

By achieving combined autonomy and interoperability, SOA enables architectural approaches that can make easy to implement decision support systems services for all the lifecycle phases.

The following features are the most prominent:

- Integration capability: services can be readily integrated with other services, either statically or

dynamically. Furthermore, services can be readily composed into higher level services.

- Owing to the abstraction between service interface and service implementation, services can be materialized on heterogeneous software and hardware platforms.
- Agility, flexibility and adaptability to change are greatly increased as services can be easily reconfigured or replaced, service deployment can be conducted incrementally and scaling can take place over time.
- Communicating entities can share and exchange resources and collaborate with each other through direct, peer to peer communication, i.e. without depending on the assistance and control of some higher level entity. Decision making can thus be driven down to the source of the information acted upon. This in turn enhances responsiveness and efficiency, while improving configurability. A decentralized mode of operation further adds resilience against failures by eliminating single point of failure hazards.
- Development cost is reduced as re use of services is facilitated and application programming is done at the highest possible level of abstraction.

systems. The combined adoption of SOA paradigm, wireless technologies and computing capabilities (through embedded systems) enable the creation of an ecosystems of smart and autonomous devices that can independently cooperate and communicate.

By adopting SOA paradigm, both industrial devices and products could be encapsulated into WS or described as a composition of WS. Products can be represented through semantic web detailing all its components and additional (more intangible) features. SOA allows two main important opportunities:

- Seamless interaction with “things” (i.e: enterprise systems, customers, other devices through the overall lifecycle, other product, etc.)
- Seamless inclusion of even more intangible aspects such as services or functionalities.

## 8 SERVICE ORIENTED ARCHITECTURE FOR EXTENDED PRODUCT LIFECYCLE MANAGEMENT

The adoption of Service-oriented Architecture, through the various available tools (DPWS, WSDL, etc.) is fundamental in order to describe and include product's features and additional services as described in the concept of Extended Product enabling interoperability with heterogeneous “things” (devices, other products, etc.). Hence, thanks to the extreme flexibility of SOA paradigm, the previously explained concept of Avatar, that is the digital shadow of the product, should be seamlessly implemented through the adoption of WS technologies.

Given to the products the necessary computing and communication capabilities provided through the adoption of embedded systems and wireless technologies, thanks to SOA paradigm as conceptual way of creating systems, products can effectively become autonomous agents with the capability of interacting with other devices at low level but also with higher enterprise systems or also with customers. Moreover, it could be possible to effectively represent and identify the services and the functionalities on the product itself, in order to let it become an Extended Product with a clear embedded representation of the Avatar through WS.

Analyzed the current status of the proposed reference architecture for ExtPLM proposed within the PROMISE project and the under development architecture that is under development within the Socrates project, it is possible to see a desirable convergence toward a Service Oriented Architecture to be used for Extended Product Lifecycle Management.

Such a kind architecture could implement the ideas of ExtPLM in a modular way. The structure for communication and product traceability could be set up, using the PROMISE results; in fact the developed middleware could be used a “traceability” service, while the PDKM SOM could serve as the data structure, the ontology to structure the data exchange within the system.

This approach will have the advantage that then it will be possible to implement each specific service toward the customer and the product stakeholders as a web service, such a way it will be easy to add, manage and restructure services, since each one of them will have just to define its own required data within the given structure and its own way of working. Also the update of the system will be

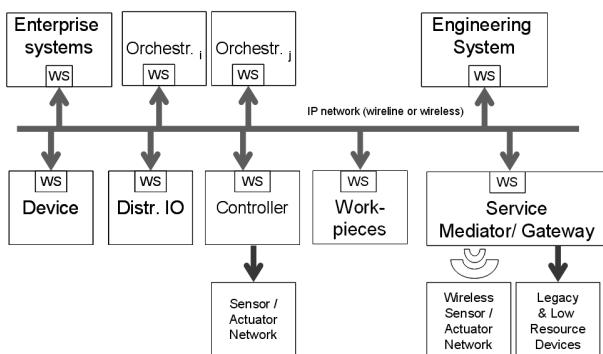

Figure 3: Service Oriented Architecture Schema

One relevant European project that is developing the implementation of SOA paradigm down to the device level is SOCRADES [18]. Its technical approach is to create a service-oriented ecosystem: networked systems are composed by smart embedded devices interacting with both physical and organizational environment, pursuing well-defined system goals. Taking the granularity of intelligence to the device level allows intelligent system behaviour to be obtained by composing configurations of devices that introduce incremental fractions of the required intelligence. This approach favours adaptability and rapid reconfigurability, as re-programming of large monolithic systems is replaced by reconfiguring loosely coupled embedded units. The use of device-level Service Oriented Architecture, contribute to the creation of an open, flexible and agile environment, by extending the scope of the collaborative architecture approach through the application of a unique communications infrastructure, down from the lowest levels of the device hierarchy up into the manufacturing enterprise's higher-level business process management systems.

Moreover SOCRADES is developing and studying the adoption of embedded systems and wireless technology in order to provide industrial devices with the technical autonomy and independence needed for the implementation of such interoperable and reconfigurable

easy since each WS will be seen by the system as a black box.

Such a system, creating an easy interoperability of the product, could also allow it to interact with a multi layer decision making system, where decisions that have to be taken at lower levels (e.g. when to manufacture a product) can be redirected ad higher level where there is complete awareness of the whole system. This kind of issue could be handled thanks to SOCRADES general architecture since a unique communications infrastructure, down from the lowest levels of the device hierarchy up into the manufacturing enterprise's higher-level business process management systems, will be available.

## 9 CONCLUSION

This paper envisions that the adoption of SOA can support both from a conceptual and practical point of view all the aspects of Extended Product Lifecycle Management. Hence, the trend of products more and more provided with services (described by the concepts of Extended Product) can be effectively satisfied providing also all the advantages of a PLM point of view

The ExtPLM concept requires a seamless integration that is possible to achieve through the SOA paradigm. The product will also require that communication will be enabled among multiple heterogeneous entities through a common language. The basis for this kind of ExtPLM architecture has been already developed within the PROMISE project that deployed a Product Data Knowledge Management ontology and an effective middleware. The Socrates project developed a Service Oriented Architecture that enables device level communication, shop floor management and multi layer decision making systems.

Starting from these results, an architecture for ExtPLM could be developed such a way to be flexible, powerful and interoperable. Moreover, thanks to the WS structure and the WS metaexchange it will be possible to add easily new services to the architecture, creating and deploying continuously new services for the customers.

## Acknowledgments

This work has been developed merging two European Project; PROMISE PROduct lifecycle Management and Information tracking using Smart Embedded systems (No. IST-2004-507100) and SOCRADES .... The authors thank all partners, and the European Commission for their support.

## References

- [1] Garetti M. Terzi S., 2004, *Product Lifecycle Management: definition, trends and open issues*, Proceedings at III International Conference On Advances In Production Engineering, 17 - 19 June 2004, Warsaw, Poland
- [2] Stark J., (2004), *Product Lifecycle Management: Paradigm for 21st century Product Realisation*, Springer, ISBN: 1852338105
- [3] Jansson K., Thoben K.-D.; *The extended products paradigm. An introduction*. DIISM2002 - The 5th

- International Conference on Design of Information Infrastructure Systems for Manufacturing 2002, Osaka, Japan.
- [4] Hirsch B. E., Thoben K.D. and Eschenbaecher J., 2001, *Using e-business to provide Extended Products*, Automation, Automation days, Helsinki, Finland.
- [5] McFarlane D., J. Sarma, G. Chirn, J. Wong, A. Ashton, 2003, *Auto-ID systems and intelligent manufacturing control*, Journal of Engineering Applications of Artificial Intelligence, 16 : 365 – 376
- [6] Hribernik K, Rabe L., Schumacher J., Thoben K.D., *A Concept for Product-Instance-Centric Information Management*, 11th International Conference on Concurrent Enterprising, Munich 2005, pg. 427-434.
- [7] J. Cassina, *Extended Product Lifecycle Management*, PhD thesis at Politecnico di Milano, April 2008
- [8] J. Cassina, M. Taisch, *A Vision on Extended Product Lifecycle Management*, APMS – Innovation in networks, 14-17 September 2008, Espoo, Finland.
- [9] Jun, H., Kiritsis, D., and Xirouchakis, P. 2007. *Research issues on closed-loop PLM*. Comput. Ind. 58, 8-9 (Dec. 2007), 855-868.
- [10] J. Cassina, M. Taisch, D. Potter, A.K. Parlikad, *Development of PROMISE Architecture and PDKM Semantic Object Model*, ICE 2008, 23-25 June, Lisboa, Portugal.
- [11] E. Newcomer and G. Lomow - *Understanding SOA with Web Services* - Addison Wesley - 2005
- [12] M. Bell - *Service-Oriented Modeling (SOA): Service Analysis, Design, and Architecture* - Wiley & Sons - 2008
- [13] T. Erl - *Service-oriented Architecture: Concepts, Technology, and Design* - Upper Saddle River: Prentice Hall PTR - 2005
- [14] F.Jammes and H.Smit - *Service-Oriented Paradigms in Industrial Automation* - IEEE Transactions on Industrial Informatics, VOL. 1, NO. 1, February 2005
- [15] F.B. Vernadat - *Interoperable enterprise systems: Principles, concepts, and methods* - Annual Reviews in Control, 31 (2007) 137–145
- [16] W.A. Estrem - *An evaluation framework for deploying Web Services in the next generation manufacturing enterprise* - Robotics and Computer Integrated Manufacturing 19 (2003) 509–519
- [17] W.Y. Zhang, J.W. Yin - *Exploring Semantic Web technologies for ontology-based modeling in collaborative engineering design* - Int J Adv Manuf Technol (2008) 36:833–843
- [18] SOCRADES website <http://www.socrades.eu>