

CRANFIELD UNIVERSITY

XIAOLI GE

KNOWLEDGE MODELLING OF CNC TOOL PATHS
FOR FUNCTION BLOCKS

SCHOOL OF APPLIED SCIENCES

MSc by Research Thesis
Academic Year: 2012 - 2013

Supervisor: Dr Jörn Mehnert, Dr Yuchun Xu
November 2013

CRANFIELD UNIVERSITY

SCHOOL OF APPLIED SCIENCES

MSc by Research Thesis

Academic Year 2012 - 2013

XIAOLI GE

Knowledge Modelling of CNC tool paths
for Function Blocks

Supervisor: Dr Jörn Mehnen, Dr Yuchun Xu
November 2013

This thesis is submitted in partial fulfilment of the requirements for
the degree of Master of Science

© Cranfield University 2013. All rights reserved. No part of this
publication may be reproduced without the written permission of the
copyright owner.

ABSTRACT

Since the first CAPP (Computer Aided Process Planning) came out in the 1960's, it has improved the performance of machining significantly. However, traditional process planning is established on the basis of a sequential information flow, which cannot easily be adapted to a dynamic manufacturing environment.

DPP (Distributed Process Planning) was proposed for dynamic shop floor management for Function Blocks (Wang et al., 2003). Function Blocks, as described by the open standard IEC 61499, are used for distributed control and automation (International Electrotechnical Commission, 2005). The final goal of DPP is to develop an intelligent system which can respond to any event on shop floor rapidly and dynamically.

The tool path, which determines the movement of a tool in machining operation, is an important part of process planning.

In the past, a tool path was generated and used in a static manner (G-code), i.e. once created the path was not varied to adapt to major changes on the actual shop floor.

As a result, it is essential to build a knowledge model that can adapt tool paths rapidly in a dynamic environment.

The developed rules and recommendations can contribute to people who have less experience about NC tool path. Moreover, the research methodology could be used for other general research in knowledge capture and knowledge presentation.

Keywords: Tool Path, Process Planning, IEC 61499, Automatic Control, Dynamic Manufacturing Environment, Knowledge Modelling

ACKNOWLEDGEMENTS

I would like to express my great appreciation to my supervisors Dr. Jörn Mehnen and Dr. Yuchun Xu for their continuing support and guidance. Without their advice and encouragement, this work would not be completed.

My sincere thanks go to Dr Lihui Wang, Dr Tapoglou Nikolaos, Dr Jialuo Ding and Dr Min Wang. They gave me advice and comments during the period of this study, which clarified the research greatly.

Furthermore, I would like to thank Dr Joachim Friedhoff, Peter Everitt, Yi Xu, Fang Wei, Ting Li and all the interviewees who participated and completed the questionnaire and semi-structured interviews. Without their coordination, the research project could not collect useful information.

Finally, special thanks should go to my sponsor Commercial Aircraft Corporation of China (COMAC) and China Scholarship Council as well as my classmates and colleagues both in Cranfield University and COMAC.

Thank you all.

TABLE OF CONTENTS

ABSTRACT	i
ACKNOWLEDGEMENTS.....	iii
LIST OF FIGURES.....	viii
LIST OF TABLES	xi
LIST OF ABBREVIATIONS.....	xii
1 INTRODUCTION.....	1
1.1 Background.....	1
1.2 Research Motivation	3
1.3 Problem Statement	3
1.4 Project Scope	4
1.5 The Collaboration Company	4
1.6 Aim and Objectives	5
1.7 Thesis Structure.....	6
1.8 Summary	7
2 LITERATURE REVIEW	9
2.1 Introduction	9
2.2 Knowledge Modelling.....	9
2.2.1 Knowledge Life Cycle.....	10
2.2.2 Sources of Knowledge	10
2.2.3 Methods and Tools for Knowledge Capture and Representation	11
2.3 CNC Tool Paths.....	14
2.3.1 Overview of Machining.....	14
2.3.2 Related Research	19
2.4 IEC 61499 and Function Blocks.....	21
2.4.1 Standard IEC 61499.....	22
2.4.2 Function Blocks	24
2.4.3 Related Research	26
2.4.4 Software Tools	27
2.5 Research Gap Analysis	31
2.6 Summary	31
3 RESEARCH METHODOLOGY	33
3.1 Introduction	33
3.2 Research Methodology Adopted.....	33
3.3 Phase1: Define Objectives and Scope.....	34
3.4 Phase2: Data Collection and Analysis	35
3.5 Phase 3: Knowledge Model Development	36
3.6 Phase 4: Validation	37
3.7 Summary	37
4 DATA COLLECTION AND ANALYSIS.....	39
4.1 Introduction	39

4.2 Initial Findings	39
4.3 Data Collection	39
4.3.1 Questionnaire	39
4.3.2 Semi-structured Interview.....	42
4.4 Data Analysis.....	42
4.4.1 General Information.....	43
4.4.2 Tool Path and Manufacturing Features	44
4.4.3 Capturing Tool Path Process Capabilities	52
4.5 Summary	53
5 KNOWLEDGE MODEL DEVELOPMENT	55
5.1 Introduction	55
5.2 Literature Review Findings	55
5.3 Investigation Results.....	56
5.3.1 Data Analysis Results	56
5.3.2 IDEF0 Map for Tool Path Generation	57
5.4 Knowledge Capture	58
5.4.1 Rules and Recommendations	58
5.4.2 Rules and Recommendations	59
5.4.3 Key Rules Selection	68
5.4.4 Knowledge Representation	69
5.5 Summary	75
6 VALIDATION OF KEY RULES	77
6.1 Introduction	77
6.2 Validation Process	77
6.3 Case Study	78
6.3.1 Application of One Key Recommendation.....	78
6.3.2 Application to a Simple Part	81
6.4 Expert Judgement.....	87
6.4.1 First Validation	87
6.4.2 Final Validation.....	89
6.5 Summary	90
7 DISCUSSION AND CONCLUSIONS	91
7.1 Introduction	91
7.2 Research Findings and Discussion.....	91
7.2.1 Literature Review	91
7.2.2 Research Methodology	92
7.2.3 Software Tool Design	93
7.2.4 Case Study and Validation	93
7.3 Research Contribution	94
7.4 Research Limitations	94
7.5 Future Research	95
7.6 Summary	95

REFERENCES.....	97
APPENDICES	104
Appendix A Interview questions and Results	104
Appendix B Questionnaire—Capturing the Machining Features and Tool Path	106
Appendix C Results of questionnaire	117
Appendix D Questions and answers of semi-structured interviews	124

LIST OF FIGURES

Figure 1-1 Thesis structure.....	6
Figure 2-1 Literature review structure.....	9
Figure 2-2 Knowledge flowchart (Ammar-Khodja and Bernard, 2008)	10
Figure 2-3 Knowledge types (Cuenca Tamarit et al., 2010; Sun, 2011)	11
Figure 2-4 Techniques from explicit to tacit knowledge (Milton, 2007)	11
Figure 2-5 Interview procedure (Abu-Nahleh et al., 2010; Sun, 2011)	12
Figure 2-6 Schematic diagram of Basic IDEF0 map (Lightsey, 2001)	13
Figure 2-7 Tool path generated by MasterCAM®.....	14
Figure 2-8 Classification of machining (Groover, 2007)	15
Figure 2-9 Two basic types of milling machine: horizontal and vertical (Groover, 2007).....	18
Figure 2-10 Zigzag tool path (Rangarajan and Dornfeld, 2004)	18
Figure 2-11 Effect of cutting speed on the surface roughness (Boothroyd and Knight, 2006).....	19
Figure 2-12 Holistic attribute adjacency graph	21
Figure 2-13 System Model	22
Figure 2-14 Device Model	23
Figure 2-15 Resource model.....	24
Figure 2-16 Application model.....	24
Figure 2-17 Basic Function Block and composite Function Block	25
Figure 2-18 Structure of Basic Function Block	26
Figure 2-19 FBDK-system configuration	29
Figure 2-20 FBDK-Composite Function Block.....	29
Figure 2-21 4DIAC-system configuration	30
Figure 2-22 4DIAC-application configuration.....	31
Figure 3-1 Adopted research methodology	34
Figure 4-1 Questionnaire structure.....	40
Figure 4-2 Examples of questionnaire.....	41
Figure 4-3 Results of general information in questionnaire	44

Figure 4-4 Method and tools for tool path generation.....	45
Figure 4-5 Common machines and materials.....	46
Figure 4-6 Procedure of machining	46
Figure 4-7 Auxiliary hole (a) for a 4-side pocket (b).....	47
Figure 4-8 Steps of machining.....	47
Figure 4-9 Procedure of tool path generation.....	48
Figure 4-10 Factors of tool path generation	48
Figure 4-11 Keep cutter constantly engaged (SANDVIK Coromant, 2013)	49
Figure 4-12 Cutting speed with material (Boothroyd and Knight, 2006)	50
Figure 4-13 Common features.....	51
Figure 4-14 Benefits of capture tool path generation.....	52
Figure 4-15 Difficulties of capturing tool path generation	52
Figure 5-1 Flow diagram of model development	55
Figure 5-2 Findings from literature	56
Figure 5-3 Initial IDEF0 map of tool path generation	57
Figure 5-4 Final IDEF0 map of tool path generation.....	58
Figure 5-5 Structure of rules (Sun, 2011)	58
Figure 5-6 Procedure of tool path.....	59
Figure 5-7 Conventional and Climb	60
Figure 5-8 Radius of tool	61
Figure 5-9 Avoid tool idling	62
Figure 5-10 Zigzag optimization	62
Figure 5-11 Ball nose end mill	62
Figure 5-12 Cutting speed of different material (Unit:m/min)	63
Figure 5-13 Example of stepover	64
Figure 5-14 Distribution of rules and selection of key rules	68
Figure 5-15 Force of different direction (Changchun University of Science and Technology, 2012)	70
Figure 5-16 Example of part.....	72
Figure 5-17 Process from interviewee.....	72

Figure 5-18 Recommend process	72
Figure 5-19 Four path pattern of 4-side pocket	75
Figure 6-1 Validation process.....	77
Figure 6-2 Case study – key recommendation 1	78
Figure 6-3 Function Block design	79
Figure 6-4 ECC design.....	80
Figure 6-5 “Conventional Cutting” algorithm design	80
Figure 6-6 Run time of Function Block	81
Figure 6-7 3D model of first case study.....	81
Figure 6-8 2D drawing of face milling part.....	82
Figure 6-9 Rule for face milling.....	83
Figure 6-10 Algorithm of length and width	84
Figure 6-11 Algorithm of stepover and stepdown – common	84
Figure 6-12 Algorithm of stepover and stepdown - FBs	84
Figure 6-13 Implemented Function Block model for face milling	85
Figure 6-14 NCspeed simulation and visualisation of the optimised tool path generated by the Function Blocks approach	86
Figure 6-15 NCspeed simulation and visualisation of a typical manual tool path as collected from the interviewees	86

LIST OF TABLES

Table 1-1 The configuration of Boeing Company's NC machine tools (Deng, 2000).....	1
Table 2-1 Examples of G-code.....	16
Table 2-2 Advantages and disadvantages of machining (Groover, 2007).....	17
Table 2-3 Tools compliant with IEC 61499.....	28
Table 3-1 Tools, methods and outputs in Phase 1	35
Table 3-2 Tools, methods and outputs in Phase 2	36
Table 3-3 Tools, methods and outputs in Phase 3	36
Table 3-4 Tools, methods and outputs in Phase 4	37
Table 4-1 List of interviewees.....	42
Table 4-2 Examples of milling machine.....	51
Table 5-1 Problems found in information collection.....	56
Table 5-2 Comparison of two process.....	72
Table 5-3 Comparison of different path patterns	75
Table 6-1 Introduction of experts for validation.....	78
Table 6-2 comparison of two methods for NC tool path generation.....	87
Table 6-3 Questions and answers of first validation	88
Table 6-4 Questions and answers of final validation	89

LIST OF ABBREVIATIONS

3D	Three Dimensional
4DIAC	Framework for Distributed Industrial Automation and Control
APP	Assembly Process Planning
CAD	Computer Aided Design
CAM	Computer Aided Manufacturing
CAPP	Computer Aided Process Planning
CNC	Computer Numerical Control
COMAC	Commercial Aircraft of China
CU	Cranfield University
DPP	Distributed Process Planning
NC	Numerical Control
ECC	Execution control chart
EU	European Union
FB	Function Block
FBDK	Function Block Development Kit
FBench	Open Source FB Workbench
GUI	Graphical User Interface
IDE	Integrated Development Environment
IDEF0	Integration Definition for Function Modelling
IEC	International Electrotechnical Commission
ISO	International Organisation for Standard
KLC	Knowledge Life Cycle
KM	Knowledge Management
PLC	Programmable Logic Control
RTE	Runtime Environment
SI	Service Interface

1 INTRODUCTION

1.1 Background

Today, almost every mechanical product undergoes a sequence of steps from design to manufacturing. In this process chain, a special series of steps have to be followed. For example in machining, essential steps involve the part design, manufacturing sequencing, cutting tool and setup selection, tool path planning and NC data generation as well as machining process simulation and finally machining (Ranky, 1983). In general, all of these steps have to be planned properly to minimise production disruption and cost. Today, this planning process can be quite challenging and thus it is often supported by computers – first described by Niebel (1965). Automated process planning is typically referred to as Computer Aided Process Planning (CAPP) (Wang and Li, 1993).

According to statistics, in industrialized countries, 50% (Japan) to 68% (the U.S.) of the national economic output is created by manufacturing, a sector having a decisive impact on national economic development (Deng, 2000).

Machining plays an essential role in enterprises. Thus, developing an advanced machine tool creates a significant advantage for enterprises over competitors. An example of this is Boeing Company, whose annual output is over 200 large aircrafts. Table 1-1 shows its Computer Numerical Control (CNC) machine configuration, size and performance (Deng, 2000). Significantly, milling machines, account for a great proportion.

Table 1-1 The configuration of Boeing CNC machine tools (Deng, 2000)

Type	Number
Aviation industrial milling machines	80
General milling machine	120
Turning machine	10
Drilling machine	28
Other	57

Typically, CNC machine tools execute their movements following G-code (Madison, 1996; Overby, 2010). G-code can be generated in two ways: manual or automatic. Computer Aided Design (CAD) and Computer Aided Manufacturing (CAM) are typically well integrated in current CNC solutions (Henderson and Anderson, 1984; Kao and Lin, 1996; Luthardt et al., 2004; Addison et al., 2012). However, most existing CAx systems are designed based on a sequential information flow. They cannot adapt to dynamic manufacturing shop floor environments (Wang et al., 2003). Once the G-code is generated and loaded into the CNC machines for production, the tool path is determined and cannot be modified. If there is a disruption in the manufacturing process, for example, a tool breaks or a new tool with slightly different properties is used, or the original CAD design needs to be altered slightly. In this case the whole tool path needs to be re-planned and re-generated from the beginning and then loaded into the CNC controller. This inflexible approach is the current state-of-the-art and demands systematic research to come up with a new and more dynamic and flexible tool path planning approach.

Knowledge Management (KM), which aims to set up organisations, methods and tools that develop the knowledge capital during the life cycle, has been a major challenge for many enterprises in the last few years. For an enterprise, knowledge is the core of its technology (Yli - Renko et al., 2001). KM can affect innovation and breakthrough on products, processes, services and organisation. Fundamentally, KM can reduce cost and maximize the profit, which is also the expectation of enterprises (Boughzala and Ermine, 2006). An essential step of KM is knowledge modelling, the aim of which is to extract professional knowledge by models (Boughzala and Ermine, 2006). Knowledge modelling, in fact, is to build a knowledge-based model with different forms, such as trees, diagrams and matrices, as well as maps (Milton, 2007).

In order to improve the current tool path planning process, fundamental knowledge about practical, i.e. manual as well as automated tool path planning is essential. Knowledge management and modelling are known to be powerful

tools that can help in capturing and representing explicit as well as and tacit (concealed) expert knowledge (Vernadat, 2003).

1.2 Research Motivation

The Collaborative and Adaptive Process Planning for Sustainable Manufacturing Environments (CAPP-4-SEMs) project cooperating with several universities and companies (European Commission, 2012), states that Distributed Process Planning (DPP) is a trend for open-architecture CNC controllers (Wang et al., 2009). The aim of the CAPP-4-SEMs project is to build an innovative knowledge-based Computer Aided Process Planning to minimise cost, improve adaptability, responsiveness, robustness, and sustainability of the manufacturing processes. However, this hypothesis needs to be tested and thus, a knowledge-based subsystem needs to be created that may prove or disprove this hypothesis (European Commission, 2012). Tool path generation is an essential section of CAPP. This research will contribute to an innovative and more effective use of tool path generation by capturing knowledge of tool path generation and modelling this knowledge in the form of rules and recommendations according to machining features, which should be suitable for a more dynamic shop floor.

1.3 Problem Statement

Generally, tool paths can be generated manually as well as automatically. Traditionally, once the tool path is generated and uploaded into the machine controller, cannot be changed. In fact, ideally the tool path should not be changed or updated externally at all but operated directly by a mechanism within the machine controller. However, such a novel approach towards a more flexible workshop has not been attempted before.

Using real-time system information for both planning and controlling of a manufacturing system to reduce cost is necessary. Indeed, it would be better if the time span between decision making and actual execution could be reduced to a minimum (Wang et al., 2012).

The concept of function blocks (FBs) supports the use of real-time information for dynamic distributed decision making and processed dynamic control capabilities that are able to handle different kinds of uncertainty problems in a responsive and adaptive way. Applying FBs in controllers of CNC machines and robots could mean giving these machines intelligence and autonomy to handle and adapt to changes in a very flexible manner, allowing for a more successful fulfilment of their manufacturing objectives (Wang et al., 2012).

1.4 Project Scope

This project is part of the EU project: Collaborative and Adaptive Process Planning for Sustainable Manufacturing Environments (CAPP-4-SMEs). The aim of CAPP-4-SMEs project is to enhance the competitiveness of European companies in sustainable manufacturing environment.

The scope of this research includes identification, capturing and representation of knowledge of tool path generation in industry, covering mechanical parts design and process planning; aspects that affect the generation of tool paths and CNC files directly. This is achieved through:

- Undertaking a comprehensive literature review, questionnaire and a series of interviews to identify the key considerations of tool path generation according to different machining features
- Capturing knowledge of tool path generation in the form of rules and recommendations.
- Representing the knowledge for function blocks.
- Validating the captured knowledge.

The scope of this project does not include the architecture of DPP and application of Function Blocks in DPP system. Other stages of the Knowledge Life Cycle (KLC), such as sharing of the knowledge and knowledge based engineering are deemed to be outside the scope of this research.

1.5 The Collaboration Company

The Commercial Aircraft Corporation of China (COMAC) is a State-owned company in China which cooperates widely with aircraft manufacturers or

suppliers worldwide. Aircraft design, manufacture, marketing and acquisition of certification are all included. The goal of COMAC is to develop a world-class civil aircraft industry which is safe, economical, comfortable and environmentally friendly. The manufacture department, as an important centre of COMAC, has studied CAPP for more than 10 years. Thus, all the techniques and processes which can improve the performance of manufacture are of interest.

PowerKut Limited is a family-run business which designs and manufactures products for the Mining, Rail, Construction, Aerospace, Automotive, Marine, Defence, Nuclear, Plastics and General Engineering sectors of industry. "Engineering Excellence" is the company's goal (CAPP-4-SMEs, 2012b). It participates in the Collaborative and Adaptive Process Planning for Sustainable Manufacturing Environments (CAPP-4-SMEs) as specialised in tooling, gauging and machined components.

FORMTEC GmbH (FT) was developed in 1997, supplying services and software development for the CAD-CAM-CNC process chain. The core software NCspeed is able to simulate, verify and optimise tool path for milling machines. It enables manufacturers to adjust the feed rate to optimise machining processes according to the cutting conditions automatically, which can shorten the processing time by 20% (CAPP-4-SMEs, 2012a).

1.6 Aim and Objectives

The aim of this research is to develop knowledge models for CNC machining tool path generation for Function Blocks to support Distributed Process Planning.

The objectives of this research are to:

1. Identify the methods and tools for knowledge modelling.
2. Research the capability of standard IEC 61499 Function Blocks and Function Blocks emulators
3. Capture the knowledge of manual and automatic tool path generation.
4. Propose a set of rules and recommendations for tool path planning and represent using emulators.

5. Validate the proposed implementation through case studies and expert judgment.

1.7 Thesis Structure

Seven chapters comprise this thesis, as shown in Figure 1-1. The overall background of this research is introduced in the first chapter. Chapter 2 provides a literature review about Function Blocks, knowledge management as well as CNC tool path. Chapter 3 presents the methodology for this project. In chapter 4, data about CNC tool paths was collected and analysed. Chapter 5 introduces the process of knowledge modelling, the identified rules and recommendations as well as the representation. Chapter 6 presents the validation procedure as well as expert judgement of the results. The last chapter discusses the research contribution and limitations.

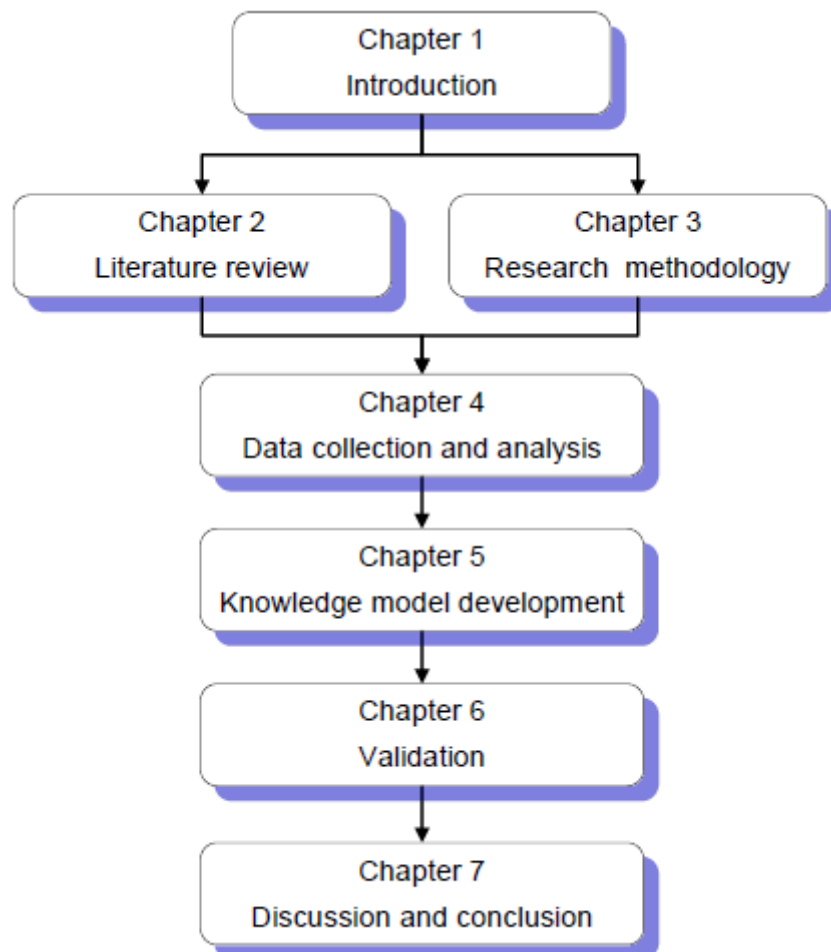

Figure 1-1 Thesis structure

1.8 Summary

A general introduction about the research has been included in this chapter. Firstly, an overall background about Function Blocks, the research motivation as well as the collaboration companies were introduced. Secondly, the research aim and objectives were mentioned. Figure 1-1 illustrates the overall thesis structure.

2 LITERATURE REVIEW

2.1 Introduction

A comprehensive literature review, conducted to obtain fundamental knowledge for this project, is divided into six sections (Figure 2-1). Section 2.1 gives a general introduction to this chapter. Section 2.2, 2.3 and 2.4 present the literature about knowledge modelling, CNC tool path as well as IEC 61499 and Function Blocks, respectively. Section 2.5 analyses research gaps. Finally, a summary of this chapter is given in Section 2.6.

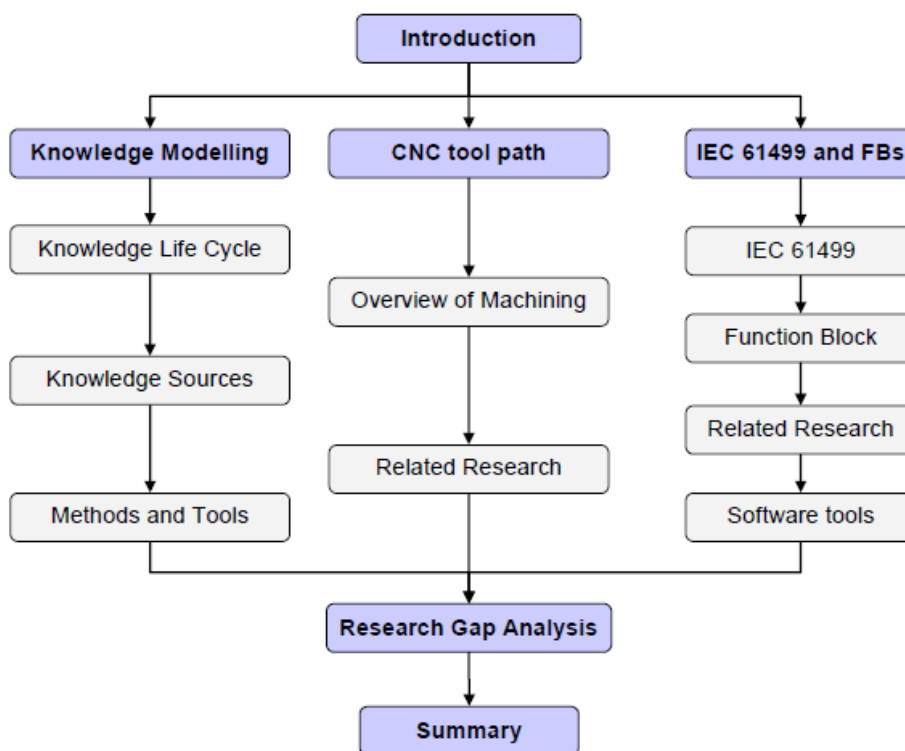

Figure 2-1 Literature review structure

2.2 Knowledge Modelling

Knowledge modelling is to create knowledge-based models, which is an essential step of knowledge management (KM) (Cuenca Tamarit et al., 2010). It enables a confusing mass of interconnected knowledge to be simple and clear. In other words, knowledge modelling is capable of breaking the knowledge down into more manageable parts which are easy to understand and manipulate, so as to capture their essential features (Abdullah et al., 2002).

2.2.1 Knowledge Life Cycle

To understand knowledge modelling, the Knowledge Life Cycle (KLC) should be reviewed first, which is concerned with management and its processes. Namely, humans collect information, manage its meaning and semantics, and convert this into knowledge. It can be regarded at a personal as well as an organisation level (Ammar-Khodja and Bernard, 2008).

2.2.2 Sources of Knowledge

Knowledge can be divided into explicit and tacit knowledge. In short, explicit knowledge can be gathered from norms, books, documents, technical manuscripts, drawings, databases and websites, while tacit knowledge, as the deepest and most important knowledge, is stored in people's head, and thus is difficult to gather and extract. The form can be experience, skills or others (Swartout and Gil, 1996). Figure 2-2 presents the knowledge flow between explicit and tacit knowledge (Ammar-Khodja and Bernard, 2008).

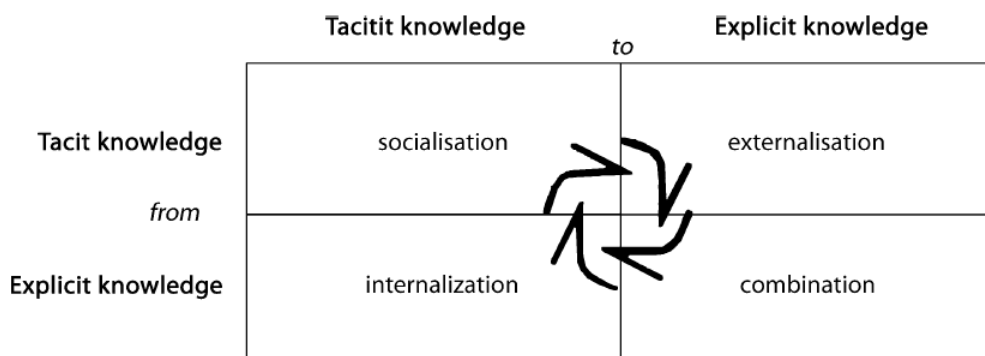

Figure 2-2 Knowledge flowchart (Ammar-Khodja and Bernard, 2008)

Figure 2-3 presents different knowledge types of explicit and tacit knowledge. It is obvious that tacit knowledge can be gathered from experience, skills or insight after training, practicing and studying. Explicit knowledge can also be captured from documents, databases from tacit knowledge, including experience and insight (Sun, 2011).

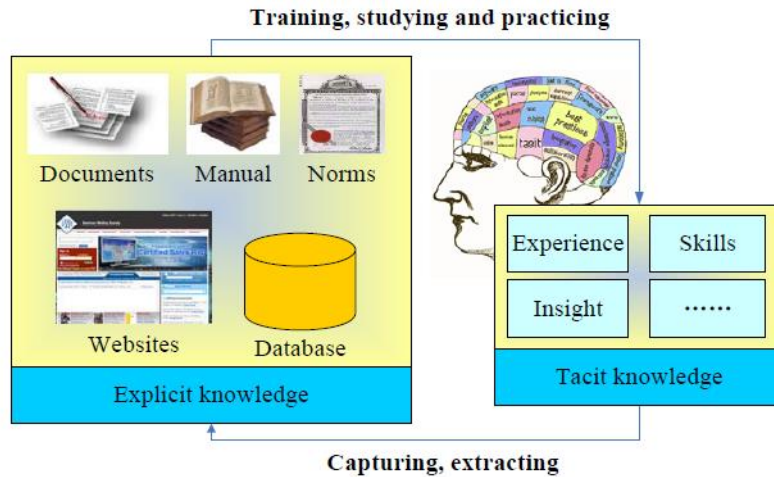

Figure 2-3 Knowledge types (Cuenca Tamarit et al., 2010; Sun, 2011)

2.2.3 Methods and Tools for Knowledge Capture and Representation

There are several methods and techniques for knowledge acquisition, such as interview, process mapping, timeline, observation, case analysis, and questionnaire. Figure 2-4 identifies the most effective techniques to capture different kinds of knowledge (Milton, 2007). Among these methods, questionnaires and interviews are the most used for tacit knowledge acquisition. In this section, some of the methods and tools are discussed.

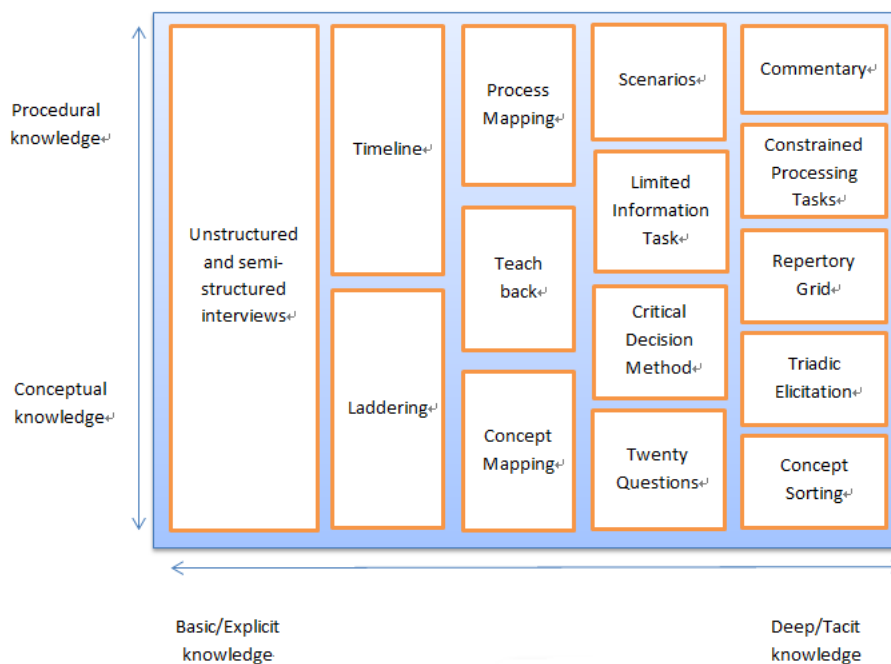

Figure 2-4 Techniques from explicit to tacit knowledge (Milton, 2007)

1) Interview

The aim of the interview is to question and gain knowledge from experts or an organisation and record the interview by media, containing video, audio or paper. This is most commonly used to gain tacit knowledge from explicit knowledge. A guideline for interviewing to capture knowledge was proposed by Sun (2011). Figure 2-5 shows the suggested procedure.

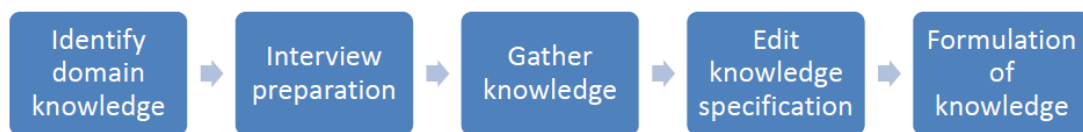

Figure 2-5 Interview procedure (Abu-Nahleh et al., 2010; Sun, 2011)

It can be divided into 3 types: unstructured interview, semi-structured interview and structured interview. They are used in different stages of research. For example, the unstructured interviews, as a free and special topic chat with an expert, usually takes place in the early phase of research. In this research, semi-structure interview was utilized to capture tacit knowledge in data collection phase while structured interview was used in the validation phase.

2) Questionnaire

The questionnaire, as a very important method to collect information, can be considered as a special kind of structured interview. The respondents answer the question independently. It is most used to capture general information. In this research, it was used to gather information about CNC tool path and knowledge management.

3) IDEF0

IDEF0 (Integration Definition for Function Modelling) is a tool based on structured analysis and design techniques, thus it is often used for describing manufacturing functions (Lightsey, 2001). A schematic diagram of an IDEF0 model is shown in Figure 2-6, with a centre box and arrows. It clearly shows the related information and objects, correlations and restrictions between functions in a system. Inputs, Controls, Outputs, and Mechanisms which influence the

system as well as the resources required by the functions are also indicated in an IDEF0 diagram (Winch and Carr, 2001).

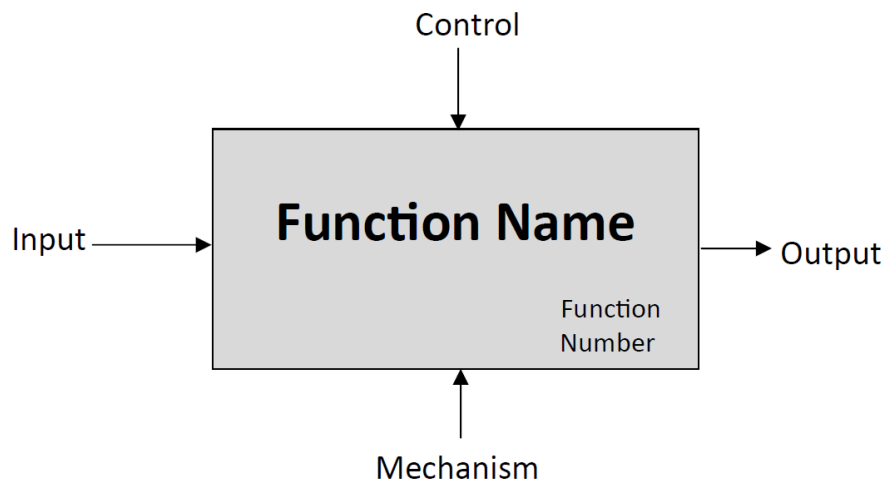

Figure 2-6 Schematic diagram of Basic IDEF0 map (Lightsey, 2001)

Process mapping by IDEF0 is highly effective for process knowledge modelling. Thus, almost all the considerations about the process can be identified through the IDEF0 map, which makes process knowledge capturing much easier. Wang (2012) utilized the IDEF0 map to analyse the procedure of a web-based process planning, thus enabling the procedure to be clear and easy to understand.

4) Rules

Knowledge acquisition is the essential issue for knowledge management, yet it is also regarded as the bottleneck (Wang and Dong, 2009). As proposed by Wang and Dong, knowledge can be existed in different forms, for instance, mappings, tables, documents, rule sets. Rules are the common tool used to gather and represent knowledge, especially IF-THEN rules (Sun, 2011). The IF-part contains one or more conditions and is called the antecedent, whilst the THEN-part is the consequent (Chen et al., 2011). Application of rules in welding can be found in Sun (2011) who used IF-THEN rules to suggest suitable structure design and process planning for LBW in the aircraft industry.

2.3 CNC Tool Paths

Tool paths are series of coordinate positions that manage the movement of a tool during a machining operation (Paul, 1979). A CNC tool path has several elements to control the tool movement. Though tool path can be generated by different software and postprocessors, the elements are the same, such as the start position, the end position, and cut depth. Figure 2-7 shows the simplest example of a tool path which was generated by the software MasterCAM®.

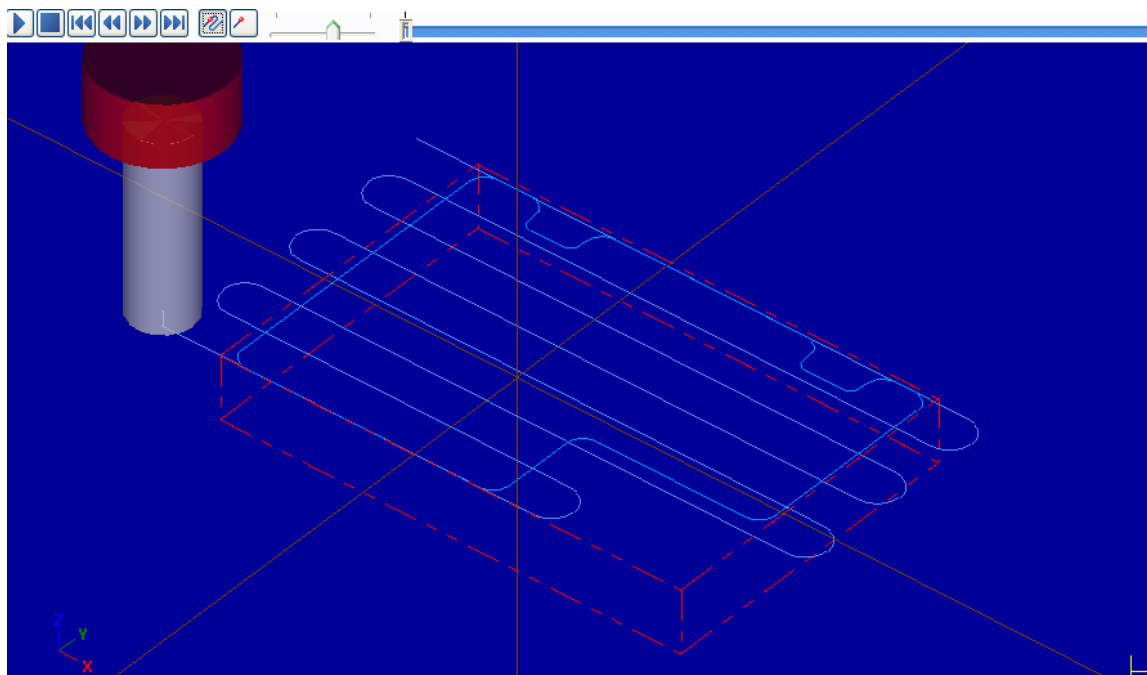

Figure 2-7 Tool path generated by MasterCAM®

2.3.1 Overview of Machining

To understand CNC tool paths, the machining should be reviewed first because a CNC tool path is an important section of machining. In general, machining is a manufacturing process in which cutting tools are used to cut away material to leave the desired part shape. Machining can be classified into three categories, as illustrated in Figure 2-8 (Groover, 2007). Among these processes, turning, drilling, and milling are three principal machining processes.

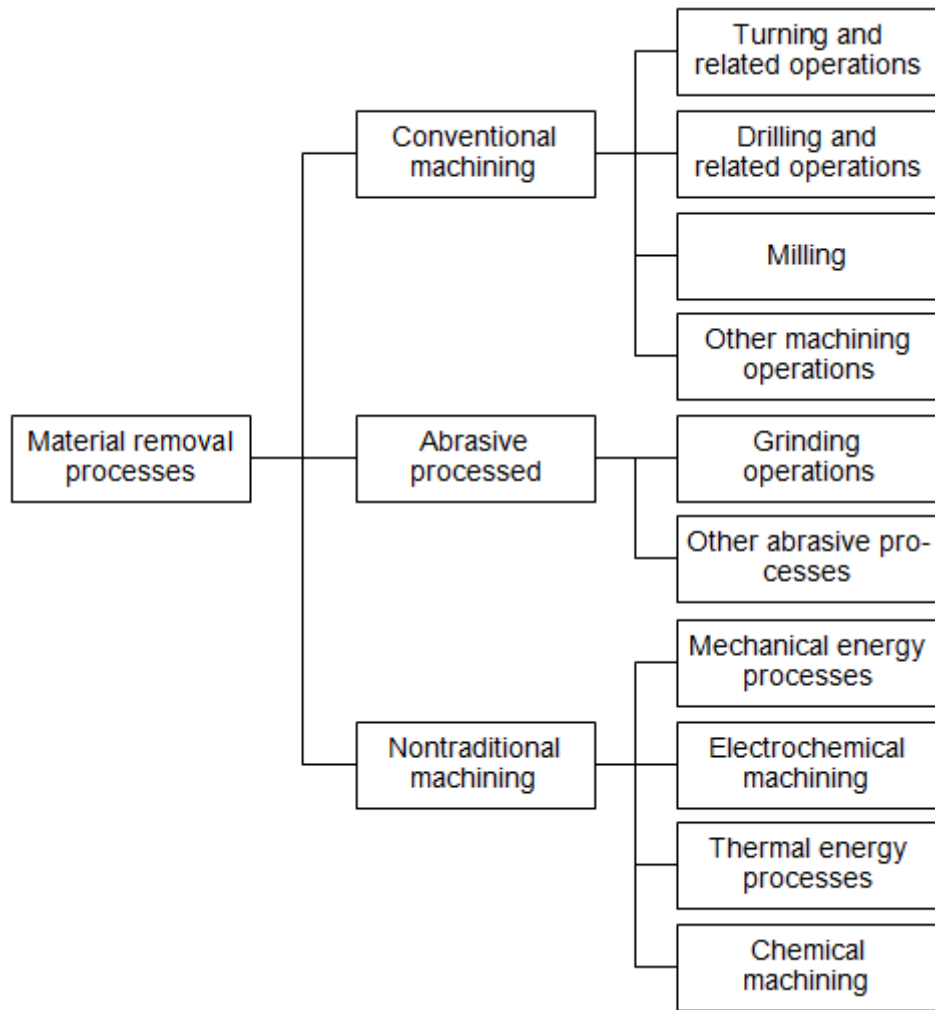

Figure 2-8 Classification of machining (Groover, 2007)

2.3.1.1 Programming Language

G-code is the most widely used numerical control programming language, which is mainly used for automation and computer-aided engineering. G-code is sometimes referred as G programming language.

Two systems should be defined in the process planning: machine coordinate system and workpiece coordinate system. A machine coordinate system is defined by the vendor while a workpiece coordinate system is defined by the designer (Madison, 1996).

In basic terms, G-code is used to tell the machine what to do and how to make it. The “how” is defined as a description of where to move, how fast to move, and by what path. The most common situation is that the cutting tool is moved

according to these instructions, and the excess material is cut off leaving only the finished workpiece. Table 2-1 shows the common G-codes which are used for milling.

Table 2-1 Examples of G-code

Code	Description	Example
G00	Rapid positioning	G00 X75 Z200
G01	Linear interpolation	G01 X40 Z20 F150
G02	Circular interpolation, clockwise	G02 X60 Z50 I40 K0 F120
G03	Circular interpolation, counter clockwise	G03 X60 Z50 I40 K0 F120
G17	XY plane selection	G17 G03 G90 X5. Y25. I-20. J-5.
G18	XZ plane selection	G18 G03 G90 X5. Z25. I-20. J-5.
G19	YZ plane selection	G19 G03 G90 Y5. Z25. I-20. J-5.
G28	Return to home position (machine zero, aka machine reference point)	G28 Z0
G90	Absolute programming	N0010 G90 G92 x20 z90
G91	Incremental programming	N0010 G91 G92 X20 Z85

2.3.1.2 Machining: Advantages and Disadvantages

Machining is one of the most important manufacturing processes. Compared to casting or forging, many advantages for machining have been identified in the literature.

First, many materials can be used for machining, from plastic to titanium. Pessoles and Tournier (2009) developed special algorithms for improved surface roughness to compute 5-axis cutter locations on free-form cavities. Surface roughness is recognised as highly important factor in machining. Thus, the polishing operation for plastic injection mould is carried out mainly by

experienced workers. However, automatic polishing operations on milling centres achieved similar quality and reduced the costs (Pessoles and Tournier, 2009). The spectrum of material that can be machined reaches from plastic to titanium. Thomas (2010) presented that microstructural damage is caused from high-speed milling of titanium alloys. In general, a variety of work materials is available for milling which may not be available for other manufacturing processes. One example is casting, in which the main materials are generally limited to metals (Chastain, 2004).

Other advantages, such as accurate dimension and better surface finishes are also notable. For some special materials, machining processes can achieve tolerance of $\pm 0.025\text{mm}$ ($\pm 0.001\text{in}$), which is much more accurate than most other processes (Groover, 2007). All advantages and disadvantages of machining are listed in Table 2-2.

Table 2-2 Advantages and disadvantages of machining (Groover, 2007)

Advantages	Disadvantage
<ul style="list-style-type: none"> ✚ Variety of work materials ✚ Variety of part shapes and geometric features ✚ Dimensional accuracy ✚ Good surface finishes 	<ul style="list-style-type: none"> ✚ Wasteful of material ✚ Time consuming

2.3.1.3 Factors of Tool Path

A milling machine must provide a rotating spindle for the cutter and a table for fastening, positing, and feeding the workpiece (Smid, 2003). Various machine tool designs satisfy these requirements. There are two basic types of milling machine: horizontal and vertical, as shown in Figure 2-9 (Groover, 2007). A horizontal milling machine has a horizontal spindle, and this design is well suited for performing peripheral milling on workpieces that are roughly cube shaped. A vertical milling machine has a vertical spindle, and this orientation is appropriate for face milling, end milling, and surface contouring.

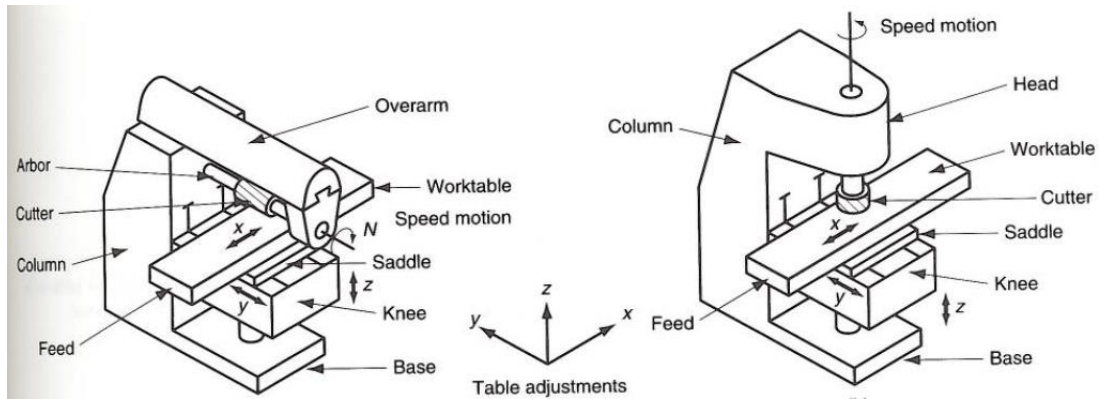

Figure 2-9 Two basic types of milling machine: horizontal and vertical (Groover, 2007)

The tool path usually is generated by a CAM system. The common schemes for face and pocket milling are zigzag and contour parallel tool path (Rangarajan and Dornfeld, 2004). Figure 2-10 presents the zigzag tool path. In order to identify efficient tool path and part orientation for facing, Rangarajan and Dornfeld (2004) designed experiments and demonstrated the advantages of orienting the part and tool path.

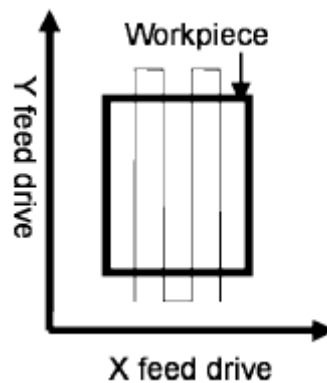

Figure 2-10 Zigzag tool path (Rangarajan and Dornfeld, 2004)

Surface roughness can be considered as a very important test index of final CNC tool paths (Benardos and Vosniakos, 2003). One of main factors contributing to natural surface roughness is cutting speed v (Boothroyd and Knight, 2006). Figure 2-11 shows the effect of cutting speed on the surface of turned specimens of mild steel. Benardos and Vosniakos (2006) also present

machine tool including vibrations and movements, work material and feed mechanism may affect the surface roughness.

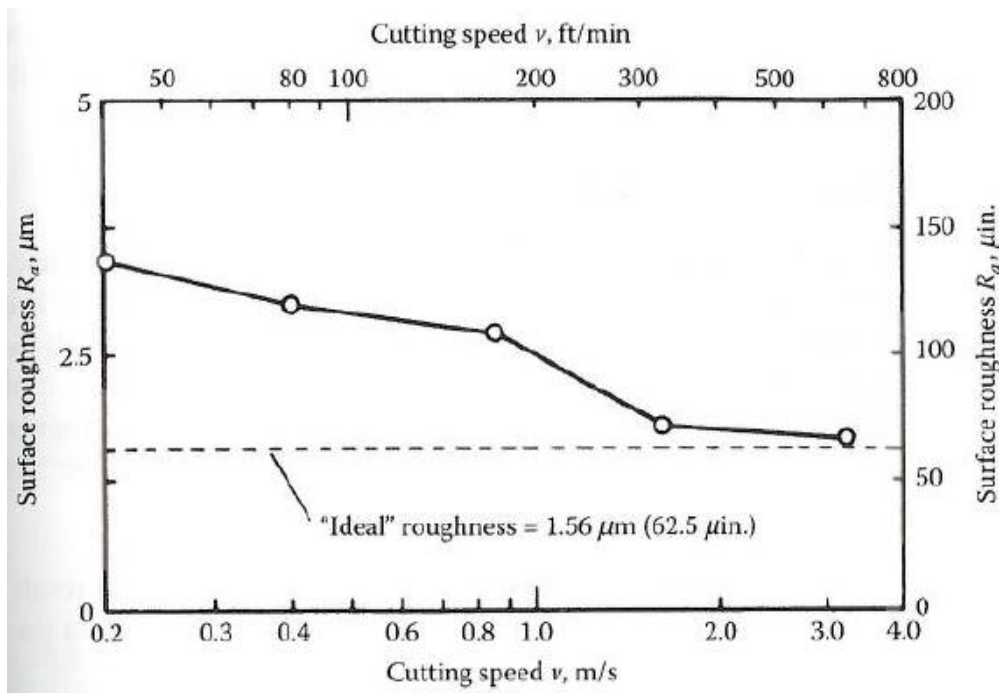

Figure 2-11 Effect of cutting speed on the surface roughness (Boothroyd and Knight, 2006)

2.3.2 Related Research

Two different modes of CNC tool path generation refer to knowledge management: knowledge-based system and feature-based system.

2.3.2.1 Knowledge-based System

Generally speaking, a knowledge-based system contains three main sections: the knowledge base, the inference engine and the user interface. It can be regarded as an expert system (Xu et al., 2011).

In CAPP, a considerable amount of experience or knowledge is important for developing an expert system, especially for the selection of cutting tools and determination of machining conditions. Arezoo (2000) presented a knowledge-based system for selection of cutting tools and conditions of turning operations, called EXCATS. The selection of tool holder, insert and cutting conditions (feed,

speed and depth of cut) were considered in the system, which can analyse and optimise the selection.

D'Souza and Ahmad (2006) presented genetic algorithms for tool sequence selection for pocket machining. Four methods based on the basic graph algorithm are investigated in this research. The aim of this research was to minimise tool change for efficient machining.

Cai (2003) presented an ISO-scalloping method of generating tool paths with a drum taper cutter to produce shorter tool paths and hence a reduction in machining time. A drum taper cutter can avoid gouging in surface machining. An improved algorithm for calculating the interval between tool paths was also shown. It was suggested that this combination of method and tool could be used for machining impeller blades or geometries with narrow surface channels, typical of aerospace products.

2.3.2.2 Feature-based Technologies

Hou et al. (2006) discussed the automation of tool path generation with an integration layer between FBMach and Unigraphics based on machining features. The integration layer enables product information as well as process information to be available immediately in an electronic form for the preparation of tool paths. The integrated system automates the process of tool path generation from solid models and significantly reduces user interactions and the amount of time preparing tool paths.

Li et al. (2008) presented a feature-based rapid programming system for aircraft NC parts. In this research, XML was taken as data transfer standard between the technology of feature recognition for aircraft NC parts and the algorithm of tool path generation based on features.

Xiong et al. (2011) presented a curvilinear tool path generation method with implicit moving boundaries for pocket machining. The combined tool path consisting of a curvilinear line and continuous arcs possesses the advantages of both of the two individual tool paths. The proposed method can also manage tool path generation for a complex pocket with an island.

Wang et al. (2013) presented a feature-based Agent-driven NC tool path generation to support design and process changes. This method uses an object-oriented collaboration framework to implement well-defined machining features which are activated by agents to formulate the proper responses automatically. This research demonstrated that it is possible to automatically generate tool path by features. In this research, features are represented and stored by a holistic attribute adjacency graph, as shown in Figure 2-12. It focused on aircraft structure design without using function blocks. When the design changed, the graph will be changed. In fact, in this way, the tool path requires complete regeneration even if only one part changes a little and it is not necessary to change all the paths.

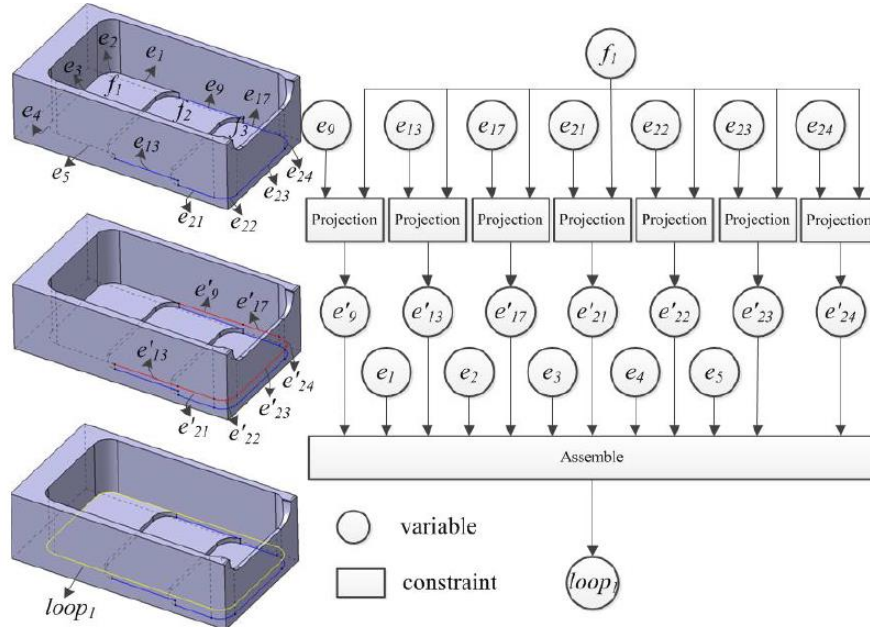

Figure 2-12 Holistic attribute adjacency graph

2.4 IEC 61499 and Function Blocks

International Electrotechnical Commission (IEC) technical committee 65 (TC65) defined IEC 61499 standard, which focuses on distributed control and automation (International Electrotechnical Commission, 2005) based on Function Blocks.

Before this, several different languages, such as Sequential Function Charts (SFCs), Structured Text, and Ladder Diagrams were used for Programmable Logic Controller (PLC) which is defined in IEC 61131. Despite existing tools for PLC design typically offering only simulation and code generation capability, it cannot provide any means for analysis based on formal models (Yoong et al., 2009).

To meet new challenges, a new event-driven model called Function Block was defined for distributed, reconfigurable and programmable features.

2.4.1 Standard IEC 61499

The new standard establishes the basic tool for controlling the processes and the distributed objects. The standard contains four parts:

- ✚ Part 1: general architecture models
- ✚ Part 2: function blocks software tools requirements
- ✚ Part 3: function block tutorial information
- ✚ Part 4: defines the structure of such compliance profiles

2.4.1.1 System Model

The system model is the top level in IEC 61499, which gives the relationship description between communicating devices and applications. It enables devices to support the execution of more than one application, as shown in Figure 2-13 (Lewis, 2001).

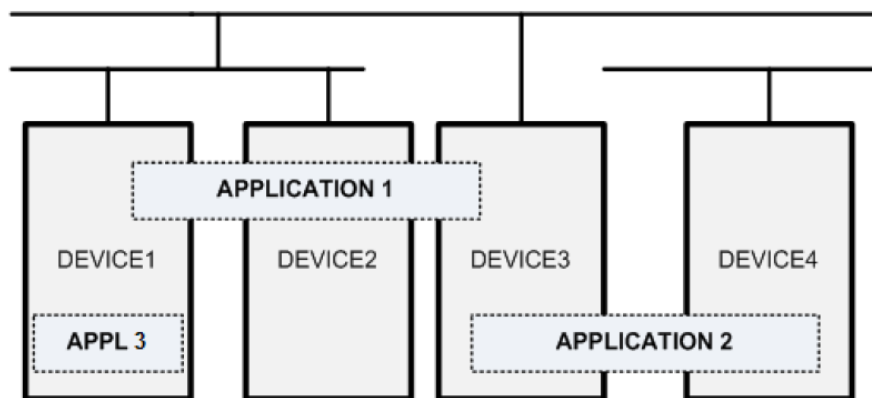

Figure 2-13 System Model

2.4.1.2 Device Model

A device is able to support one or more resources. The device model is shown in Figure 2-14 with a 'process interface'. Data is exchanged between resources and the real device through the process interface. In addition, the device model has communication interfaces which establish communication services with resources. These communications are designed to exchange information through external networks with resources in distant devices (Lewis, 2001).

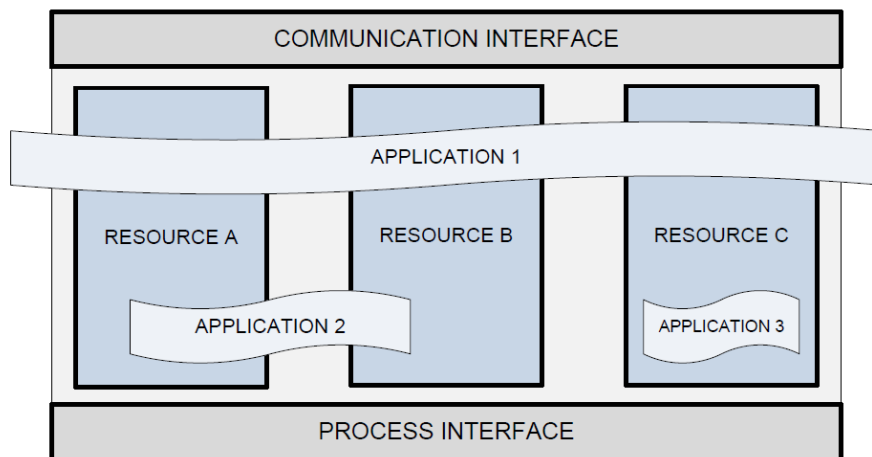

Figure 2-14 Device Model

2.4.1.3 Resource Model

The resource model allows the execution of one or more Function Block application fragments which provide facilities and services. As shown in Figure 2-15, the Function Blocks can be interconnected into a network by data and event flows. In this model, 'Service Interface' (SI) function blocks are a special form, which is a link between function blocks and the interfaces of the resource (Lewis, 2001).

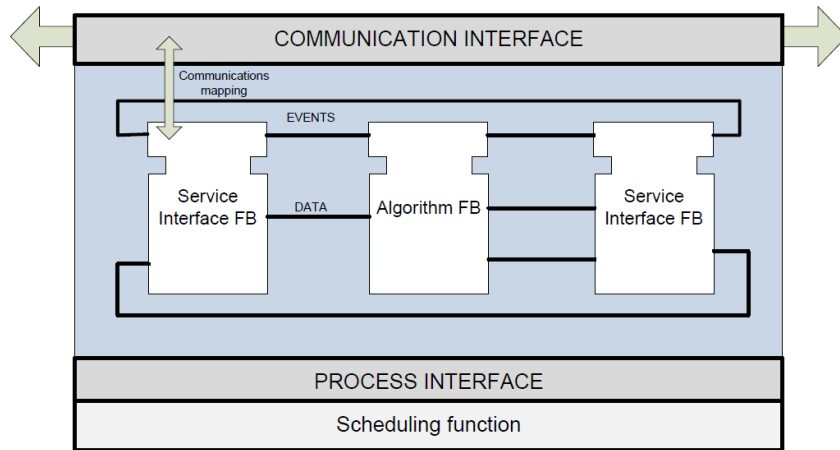

Figure 2-15 Resource model

2.4.1.4 Application Model

Several Function Blocks linked by data and event flows make up an application. In fact, this enables not only basic or composite function blocks, but also sub-applications, which can be distributed over other resources, as shown in Figure 2-16 (International Electrotechnical Commission, 2005).

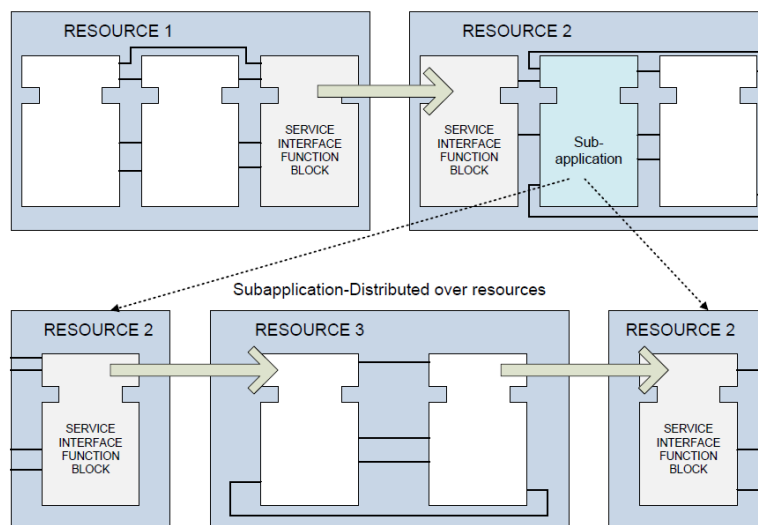

Figure 2-16 Application model

2.4.2 Function Blocks

2.4.2.1 Overview

The basic Function Block can be considered as a specific 'functional unit of software application' (Yoong et al., 2009). In the IEC 61499 standard, the

external interface and internal behaviour are described in function block as a particular type.

Figure 2-17 presents the fundamental configuration of a basic Function Block and a composite function block (Wang and Shen, 2003). The basic function block defines inputs and outputs of event and data while the composite function block is a combination of several basic function blocks. As illustrated, one FB's output event could then be the input event of another FB.

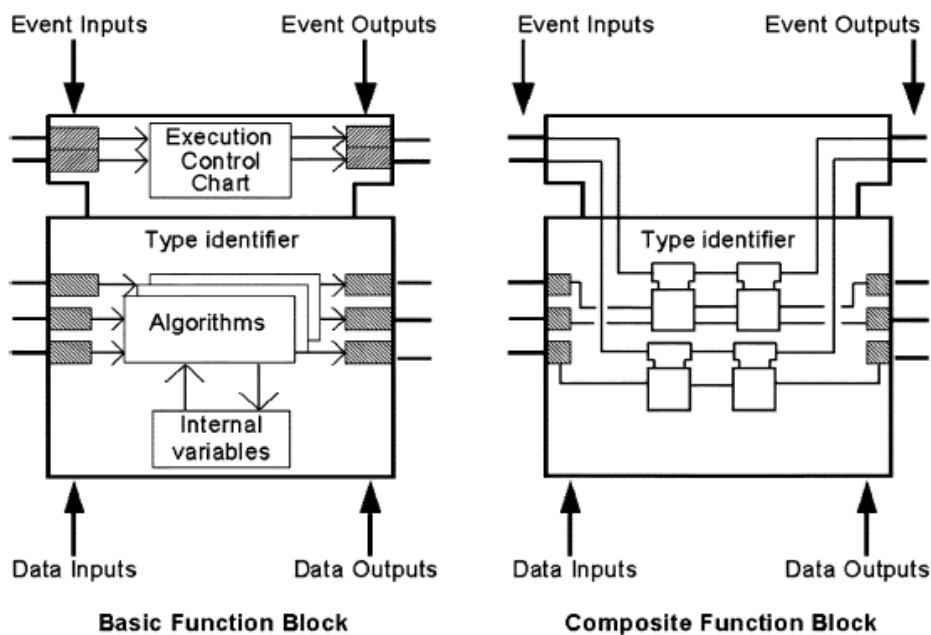

Figure 2-17 Basic Function Block and composite Function Block

2.4.2.2 Architecture

In the new standard of IEC 61499 (International Electrotechnical Commission, 2005), the basic FB is triggered by events containing inputs and outputs of data, algorithms and an execution control chart (ECC) and internal data, as illustrated in Figure 2-18. ECC is an event-driven state unit which determines the regularity of a state transition, the relationship between the state and input event and the algorithm. The algorithm determines the function block features. When a specific event occurs, the event input will be changed and drive the algorithms. The algorithm reads the input data, to produce a new value of the

internal data and outputs data according to the input data and internal data, and finally sends an event output and data output.

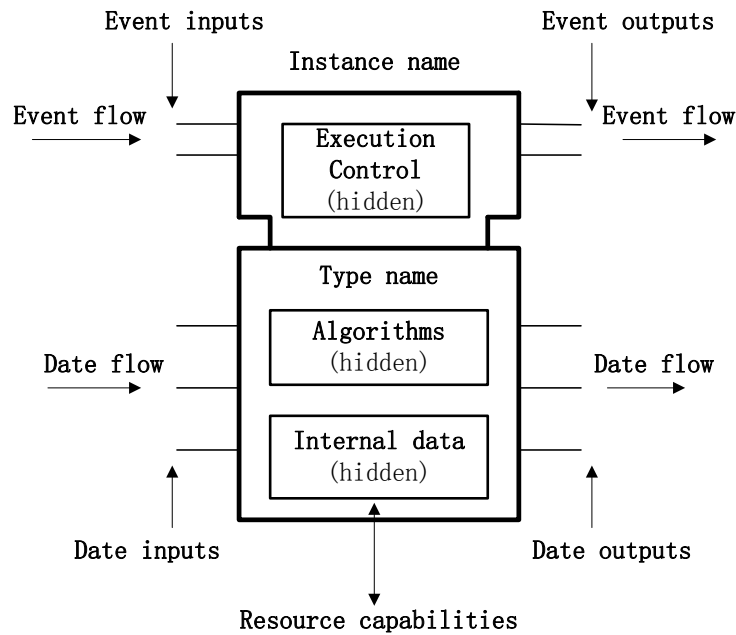

Figure 2-18 Structure of Basic Function Block

2.4.3 Related Research

Implementations of IEC 61499 Function Blocks enable control of parallelism for the distributed control system to be achieved. In this section, FBs related research will be reviewed from different aspects.

2.4.3.1 General Use

To encapsulate data is the future of autonomous distributed systems with intelligent control components (Wang et al., 2001). Therefore, FBs have increasingly become the focus of attention over the past few years. Many works of IEC 61499 in process-measurement and control systems can be found. Olsen et al. (2005) proposed a Java-based platform to implement an emerging real-time distributed control model which is distributed across two devices, supported by a manager FB. Hussain and Frey (2004) reported how IEC 61499 can model a flexible and reconfigurable distributed application, including the introduction of network-enabled hardware called NETMASTER and a software platform.

2.4.3.2 Process Planning

Applying FBs to distributed process planning was first introduced by Wang (2003). As a two-layer hierarchy is considered to separate the generic data from those that are machine-specific in DPP, machining process sequencing is treated as machining feature sequencing within the context. The advantage of this approach is that both manufacturing interactions and geometric interactions are handled during feature sequencing.

Wang (2006) proposed detailed design of Function Blocks for 15 typical machining features in DPP system. These features come from ISO 10303 standards (Wang et al., 1996; Wang et al., 2006). Meta FB, Object FB and Execution FB were developed during process planning.

Wang et al. (2008) reported another research, which applies FBs to assembly process planning. In this research, assembly features are identified and mapped to appropriate assembly FBs. More recently, three types of function blocks: machining features function block (MF-FB), event switch function block (ES-FB), and service interface function block (SI-FB) have been designed.

2.4.3.3 Execution Control

Different to FBs, STEP-NC is a new data model, superior to G-code. However, there is no corresponding STEP-NC controller. Xu et al. (2007) proposed a new mapping system, which can accept SEPT-NC data and convert it into G-code using FBs.

Minhat et al. (2007) demonstrated a novel open CNC architecture based on STEP-NC data model and IEC 61499 function blocks. This research proved that use of function block technology can enable not only the development of an open CNC system but also the implementation of separate functional units of the controller.

2.4.4 Software Tools

Currently, several tools have been built in academia and industry, including Framework for Distributed Industrial Automation and Control (4DIAC), Function

Block Development Kit (FBDK), and Open Source FB Workbench (FBench). These tools all serve as IEC 61499 development environments. However, they have a slight difference (see Table 2-3 for comments). Among these tools, FBDK and 4DIAC are the most popular tools at the moment, both of which can be used for educational and research purposes.

Table 2-3 Tools compliant with IEC 61499

Tool	Developer	Comments
FBDK	Rockwell Automation / Holobloc Inc	<ul style="list-style-type: none"> ● Free downloadable ● Educational and research purposes. ● FBRT - function block run-time environment, free to use on PC platforms for research purposes
4DIAC	PROFACTOR GmbH	<ul style="list-style-type: none"> ● Free downloadable ● a set of plugins for the Eclipse Integrated Development Environment (IDE) ● Under its Eclipse Public License
FBench	The University of Auckland (NZ)/ o3neida	<ul style="list-style-type: none"> ● Free downloadable with source code (under Common Public License agreement), ● Almost equivalent to FBDK in functionality but with a few extras. ● Extensible via plug-ins
ISaGRAF	ICS Triplex (Canada)	<ul style="list-style-type: none"> ● Commercial tool. ● Implements a limited subset of IEC 61499 and integrates it with a PLC - like scan based run-time target.

2.4.4.1 Function Block Development Kit (FBDK)

This is the original IEC 61499 software tool which was configured as a simple Java programme to draw FBs and FB networks (James et al., 2012). Figure 2-19 and Figure 2-20 give the examples of system and Composite Function Block. It can be considered as a tool for testing the graphics model and XML file exchange format.

Different to other software tools compliant with IEC 61499, the FBDK is currently unable to automatically generate the required communication Service Interface Function Blocks (SIFBs) when a FB is mapped from an (abstract) application to a (concrete) resource (James et al., 2012).

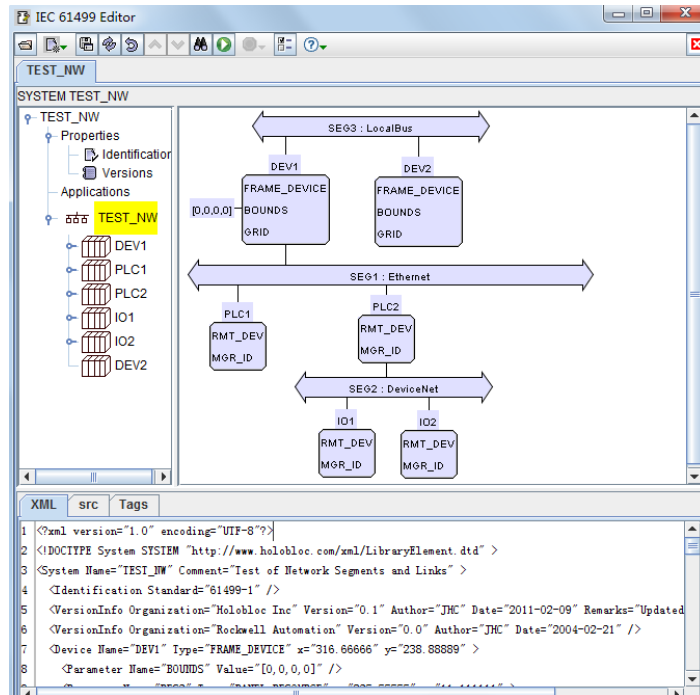

Figure 2-19 FBDK-system configuration

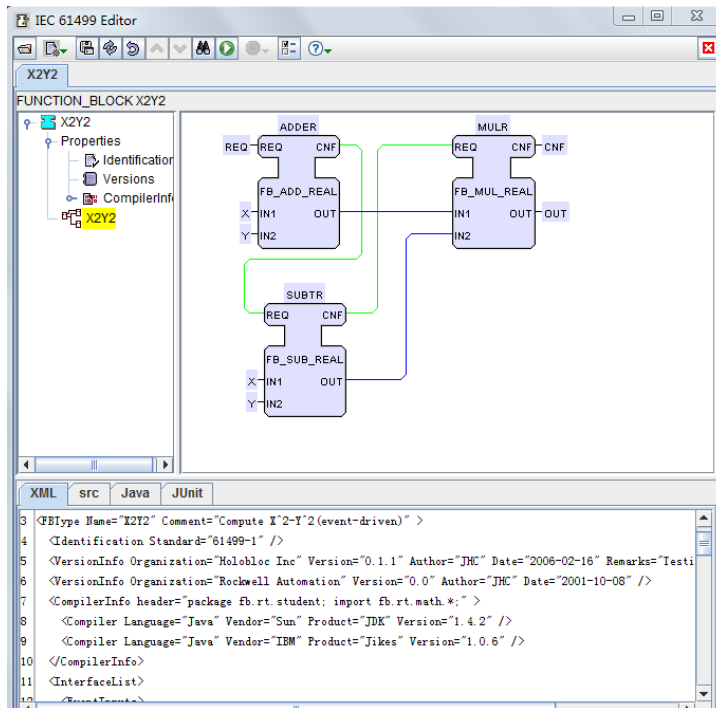

Figure 2-20 FBDK-Composite Function Block

2.4.4.2 Framework for Distributed Industrial Automation and Control

4DIAC, aimed to provide an open and free environment based on IEC61499 standard for automation and control, comprises of two projects: 4DIAC-IDE and FORTE (4DIAC-RTE).

IDE is an Integrated Developing Environment for the design and specification of IEC 61499 compliant distributed control applications. RTE is modular IEC 61499 compliant Runtime Environment for small embedded devices, implemented in C++. The IDE can download application from FORTE, in which the parameters of the download applications can be changed. Moreover, it can use target compiler to generate application and upload to FORTE. That is to say, the applications and hardware can be edited through the IDE. Figure 2-21 and Figure 2-22 gives an example of a system and application configuration.

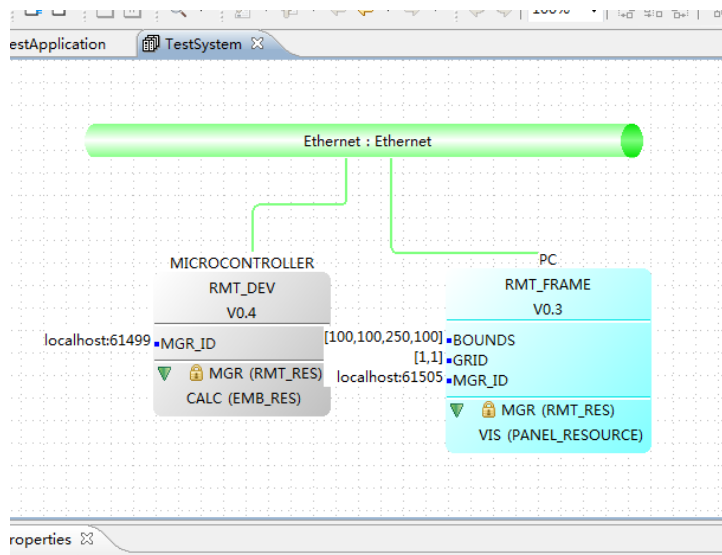

Figure 2-21 4DIAC-system configuration

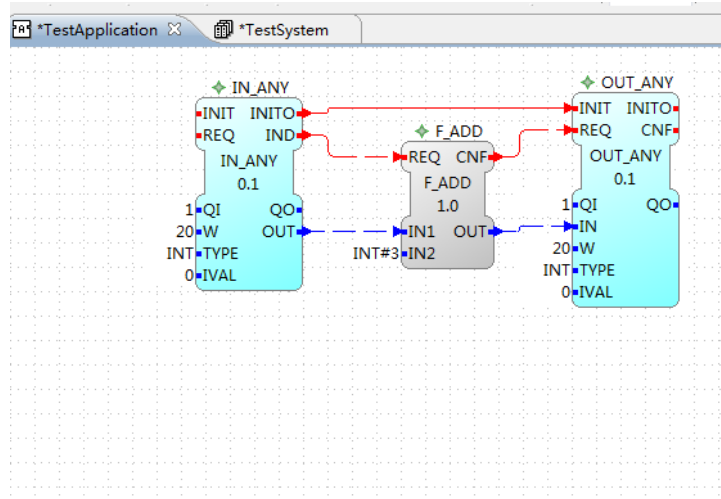

Figure 2-22 4DIAC-application configuration

2.5 Research Gap Analysis(structure modify)

It is necessary to improve machining performance using real-time system information for both planning and controlling of a manufacturing system. Function blocks provide a new and advanced way to deal with the process from designing to manufacturing. This is also the core of DPP. The technology of tool path generation using G-code has matured greatly. However, the tool path is still static, which cannot be changed in the process of manufacturing once inputted. Obviously, this tool path cannot satisfy the requirements of dynamic manufacturing environment. Although the literature about featured-based agent-driven CNC tool path generation reported a method to support design and process changes, it focused on aircraft structure design without using function blocks (Wang et al., 2013). On the other hand, Wang et al. (2006) reported 15 typical machining features with function blocks. There is little material that shows any rules and recommendations for machining features with Functions Blocks.

2.6 Summary

In this chapter, three sections were covered: knowledge modelling, function blocks and CNC tool path. Several useful methods and tools are chosen for knowledge modelling, for example, interview and mapping. From the literature review, there is little proof to show related research about knowledge modelling

of CNC tool path based on IEC 61499 function blocks. Research motivation has been verified by research gap analysis.

3 RESEARCH METHODOLOGY

3.1 Introduction

Method selection impacts greatly the research program. As a result, it is crucial to choose an appropriate method.

Two approaches are common in the research process: quantitative and qualitative (Whiteside, 2008; Sun, 2011). In general, the quantitative method verifies theories or ideas using objective statistics while a qualitative approach develops a conclusion through subjective data or information.

The aim of this research is to develop a set of rules about tool path generation, thus it involves few statistics or theory verification. Moreover, rules relate more with experience or skill. Therefore, the qualitative approach is the most appropriate methodology. In this research, literature review, interview, questionnaire and IDEF0 map are used to develop the rules for tool path generation.

3.2 Research Methodology Adopted

Figure 3-1 presents the methodology used in this research as well as the tasks and outputs in each phases. This research involves four main stages.

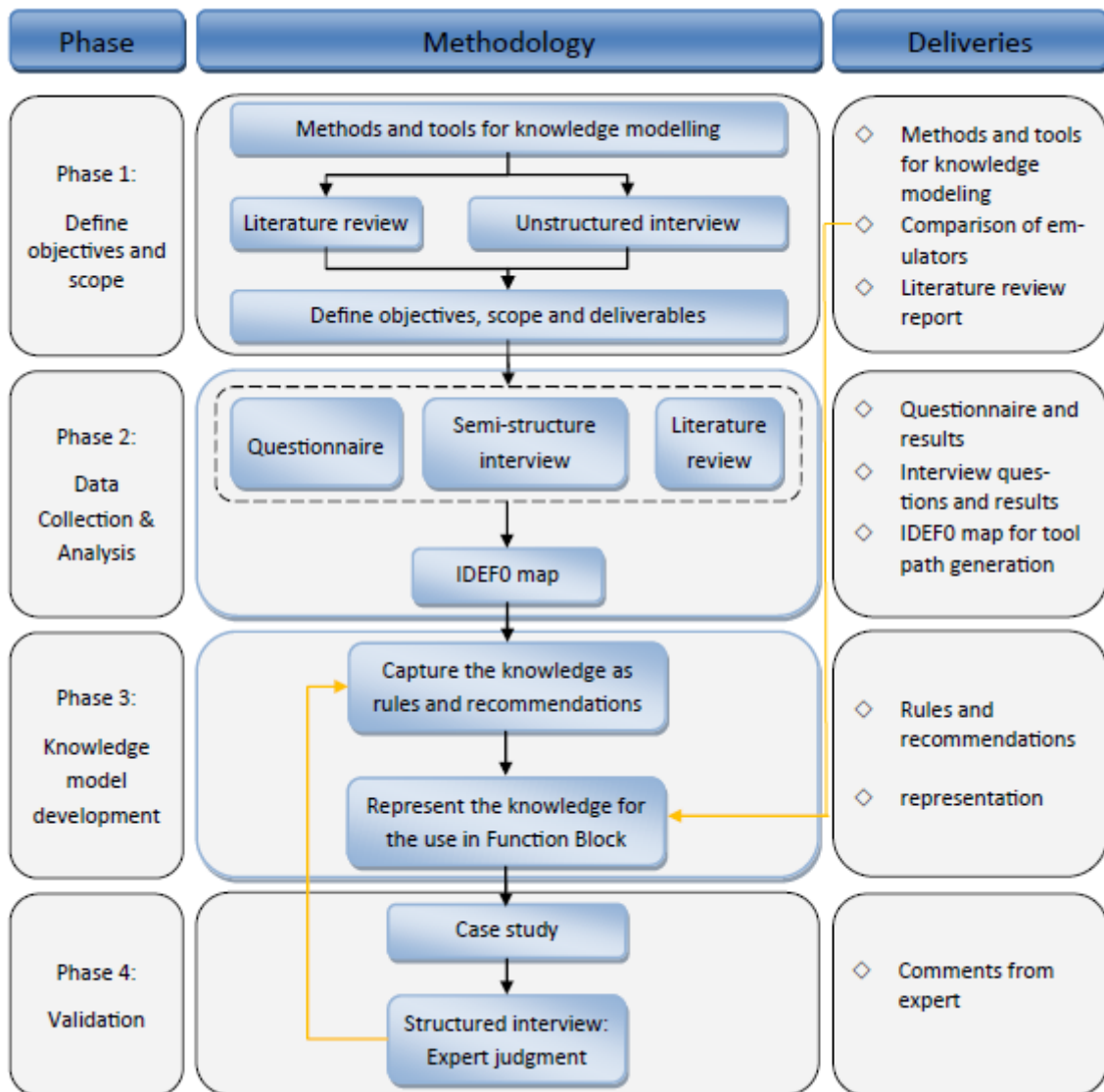

Figure 3-1 Adopted research methodology

3.3 Phase1: Define Objectives and Scope

The main task at this stage is to obtain a brief background for this research and to identify the aim and objectives as well as modelling the methods and tools.

At first, an initial literature review and a series of unstructured interviews via telephone and email about CNC tool path generation with specialists from Academics (Cranfield University) and Engineers (COMAC, PowerKut Company) were conducted. Then, a test of software was carried out. Finally, the methods and tools for knowledge modelling were identified. The key tasks, tools and outputs in this phase are listed in Table 3-1.

Table 3-1 Tools, methods and outputs in Phase 1

T1.1 define objectives and scope	
Tools and methods	<ul style="list-style-type: none"> ● Initial literature review ● Unstructured interview
Outputs	<ul style="list-style-type: none"> ● Brief understanding of Function Blocks and tool path ● Literature review report
T1.2 Software test	
Tools and methods	<ul style="list-style-type: none"> ● Software demo ● Taking Short course
Outputs	<ul style="list-style-type: none"> ● Comparison of emulators
T1.3 Identify the methods and tools for knowledge modelling	
Tools and methods	<ul style="list-style-type: none"> ● Literature review
Outputs	<ul style="list-style-type: none"> ● Identified methods and tools for knowledge modelling

3.4 Phase2: Data Collection and Analysis

The quality of data and information play an important role in the research. Therefore, the information collection for this research is based on the implementation of literature reviews, questionnaires and interviews.

The main task of a literature review, questionnaire or interview is to capture the knowledge about tool path generation. After finishing the data and information collection, bar/pie charts and process map for tool path have been utilized. An IDEF0 map was built for the tool path structure development to identify the inputs, outputs, controls and mechanics. The key tasks, tools and outputs in this phase are listed in Table 3-2.

Table 3-2 Tools, methods and outputs in Phase 2

T2.1 Knowledge capture with questionnaire, semi-structured interview and literature review	
Tools and methods	<ul style="list-style-type: none"> ● Questionnaire ● Semi-structured interview ● Literature review
Outputs	<ul style="list-style-type: none"> ● Designed questionnaire ● Literature review report
T2.2 Knowledge analysis with bar/pie chart	
Tools and methods	<ul style="list-style-type: none"> ● Bar/Pie chart ● IDEF0 map
Outputs	<ul style="list-style-type: none"> ● Analysis of the results from questionnaire ● IDEF0 map for the process of tool path

3.5 Phase 3: Knowledge Model Development

In this phase, the knowledge can be identified and developed in the form of rules and recommendations and represented for use in Function Block. The rules and recommendations were developed to suggest possible and suitable procedures, form and factors. The key tasks, tools and outputs in this phase are shown in Table 3-3.

Table 3-3 Tools, methods and outputs in Phase 3

T3.1 Capture the knowledge as rules and recommendations	
Tools and methods	Rules and recommendations
Outputs	Rules and recommendations based on the classification
T3.2 Represent the knowledge for Function Block	
Tools and methods	The adopted software
Outputs	The model for Function Block

3.6 Phase 4: Validation

The final phase is the validation of the proposed rules and recommendations. It contains two stages: case study and expert judgment.

At first, two typical structures of machining are chosen as the cases to be studied on this project. The proposed knowledge model is applied to generate a tool path, which can be simulated with adopted software and inspection. Structured interviews of experts have also been conducted during this phase. The key tasks, tools and outputs in this phase are shown in Table 3-4.

Table 3-4 Tools, methods and outputs in Phase 4

T4.1 case study with simulation	
Tools and methods	● Adopted software
Outputs	● CNC tool path simulation
T4.2 Expert judgment	
Tools and methods	● Structured interview
Outputs	● Interview results

3.7 Summary

In this chapter, the adopted research methodology was presented in four phases. The background of the project was first captured from the literature review and unstructured interviews which were followed by capturing core knowledge through questionnaire and semi-structured interviews. The data and information were then analysed using bar/pie charts and an IDEF0 map. The proposed rules and recommendations were represented for use in Function Block. Finally, the rules and recommendations were validated.

4 DATA COLLECTION AND ANALYSIS

4.1 Introduction

In order to collect information about the tool path generation, unstructured interviews, internal documents, a questionnaire, semi-structure interviews and literature review have been carried out. The information from unstructured interviews and internal documents are analysed first, which is followed by the questionnaire results represented in bar/pie charts. The questionnaire was designed and sent to COMAC in China, PowerKut in the UK and the results were then classified into procedure, factors and machining features of tool path generation, which will be discussed in Chapter 4.3. The results from the unstructured interviews are listed in Appendix A while the questionnaire and results are captured in Appendix B and C.

4.2 Initial Findings

The initial findings are formed from the unstructured interview and internal documents of COMAC. COMAC uses CATIA to build 3D models and generate too paths, which cooperates with suppliers worldwide. The experts involved in the unstructured interviews are experienced engineers in tool path generation. The unstructured interview and results are included in Appendix A. The internal documents are Chinese versions which are not included in the Appendix.

4.3 Data Collection

Based on the information relating to tool path generation from the literature review and the initial findings, a questionnaire was implemented to investigate procedure and factors of tool path generation. The questionnaire and results were sent by email, on which the semi-structured interviews were based and conducted face-to-face or via telephone discussion to collect more detailed information.

4.3.1 Questionnaire

In this project, COMAC, PowerKut and the Welding Centre at Cranfield University were chosen for investigation. The first two companies were the main

case objects, as COMAC generate tool path automatically while PowerKut often generate it manually. The two different methods broaden the spectrum of results to make the questionnaire more relevant to various industries.

The questionnaire, which comprises twenty questions, contains three parts: general information, tool path and manufacturing features, and capturing tool path process capabilities. These questions were timed to be completed in 20 minutes. Figure 4-1 illustrates the questionnaire structure.

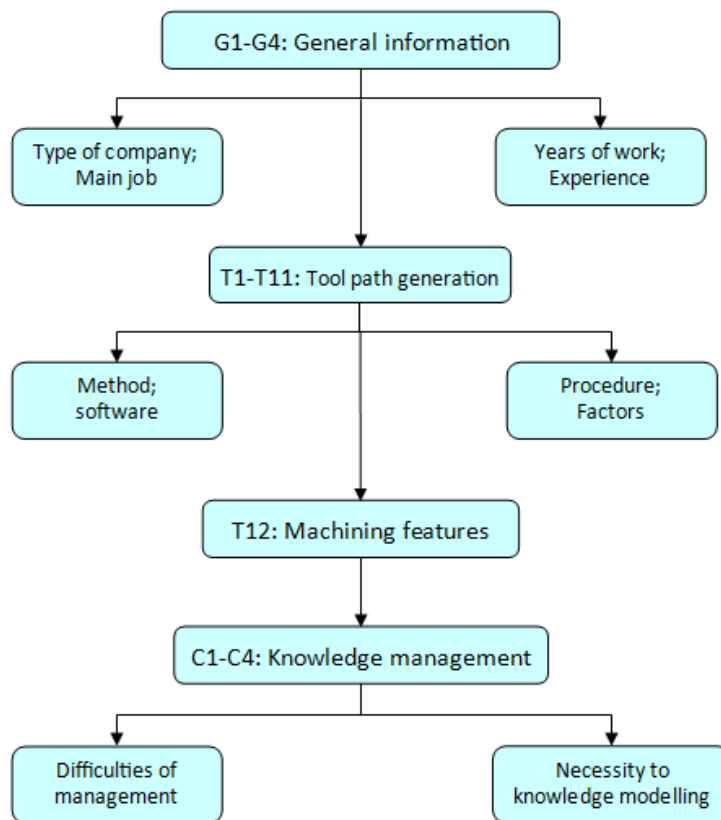

Figure 4-1 Questionnaire structure

Note: G = General information; T = Tool path C = Capturing tool path process capabilities;

Firstly, there are four questions regarding general information about the interviewees, which can verify the quality of the data source. The second section contains twelve questions to obtain basic data of tool path and manufacturing features. Finally, four questions about capturing tool path

process capability are designed to identify the necessity of its development and the difficulty in the procedure.

Because some of the respondents are Chinese, as well as English, the questionnaire was designed in two languages. Appendix B presents the English version of the questionnaire, while the Chinese version is not included in this paper. Figure 4-2 illustrates two examples of the questions in this questionnaire, which aim to identify the common material and the factors in machining.

The results of the questionnaire were collected and analysed using bar/pie charts, which are shown in Appendix C. From the results of the questionnaire, further investigation was indicated. For instance, tool is an important factor according to the results; as a result, it is necessary to design further information about tool in the semi-structured interviews to capture the knowledge of tool path.

T6. From your experience, which material would be used usually? (You can choose as many options as you wish)

- | | |
|--------------|----------|
| A. Aluminium | B. Steel |
| C. Titanium | D. Other |

Other:

T7. From your experience, what are the most important factors in machining a mechanical product? (You can choose four options at most)

- | | |
|---------------|--------------|
| A. machine | B. tool |
| C. speed rate | D. material |
| E. Coolant | F. tool path |
| G. Other | H. Not Sure |

Other:

Figure 4-2 Examples of questionnaire

4.3.2 Semi-structured Interview

According to the above questionnaire and results, a series of semi-structured interviews were conducted to obtain further information about tool path generation and machining features, such as the procedure of manufacturing, tool choice and speed limit. In this stage, the interviewees, including engineers and experts, comes from COMAC (China) and FORMTEC GmbH (Germany), who are working in different departments. The list of interviewees is shown in Table 4-1. Three manufacturing engineers were chosen because they operated CNC tool path, thus they had much experience about tool path. The questions and results of the interview are recorded in Appendix D.

Table 4-1 List of interviewees

Role	Number	Experience
Process Engineer	1	3-5 years
Structure Designer	1	3-5 years
Manufacturing Engineer	3	5-15 years
Tool specialist	1	3-5 years

Thirteen questions were designed for the semi-structured interviews relating to factor, procedure, and choice. For example, the question “Can you give some examples of milling cutters and their applications” was designed for tool factor while the question “How do you decide the path of tool? Is there any special requirement” was designed for the rule of path. The collected information and rules in semi-structure interview as well as in further literature will be discussed in Section 4.4.

4.4 Data Analysis

The answers of the questionnaire are recorded in Appendix C. In this section, the collected data and information from the three sections will be analysed using a bar/pie chart.

4.4.1 General Information

The first part of the questionnaire contains four questions of general information for different interviewees. Three organisations were chosen: COMAC, which is a manufacturing company in China; PowerKut, which is a manufacturing company in UK, and Cranfield University in the UK.

Questions G1 and G2 were designed to find the current occupation of the interviewees; G3 and G4 questions were used to indicate how much the interviewees were familiar with the tool path generation procedure.

Fifteen interviewees participated in this questionnaire. Figure 4-3 illustrates the results of the general information. In this research, different types of organisations were chosen to ensure effectiveness of this questionnaire. Figure 4-3-(b) indicated 73% of the respondents are manufacturing engineers, while others are design engineers because two interviewees from university are manufacturing engineers. All of them have the experience of process planning for tool path generation. Figure 4-3-(c) illustrates that over 60% have more than three years' experience, while only 20% of respondents have less than three years' experience. The results of general information illustrated the results from questionnaire are effective.

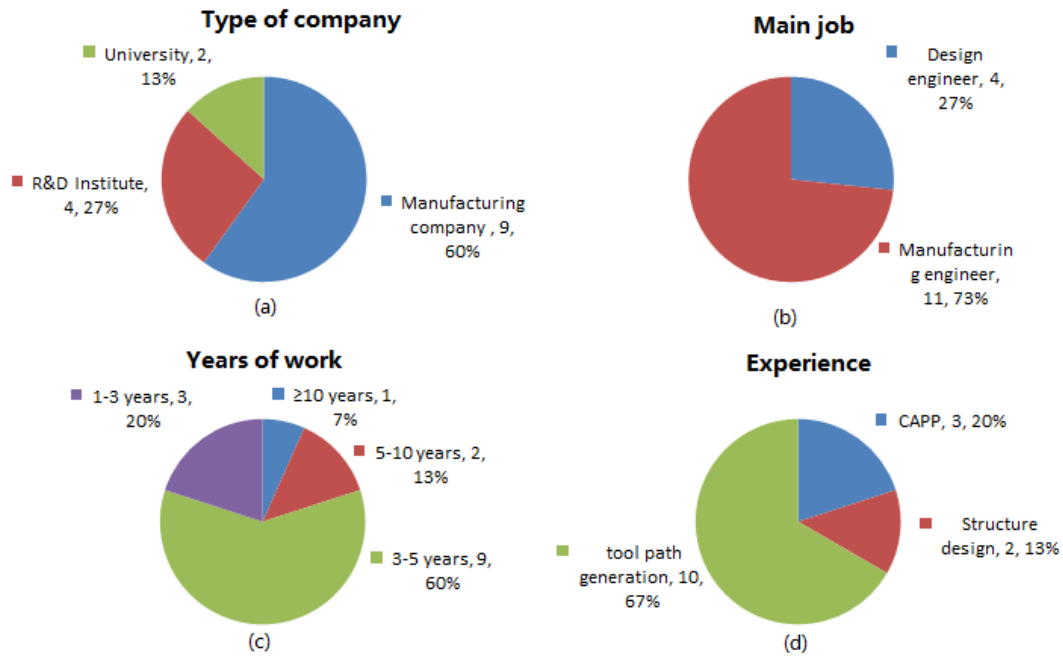

Figure 4-3 Results of general information in questionnaire

4.4.2 Tool Path and Manufacturing Features

4.4.2.1 Methods and Tools

Tool path can be generated manually and automatically. Three questions were designed to identify the methods and tools for tool path generation as well as the advantages of CAM software.

As most of interviewees came from COMAC, which generated tool path automatically, over 60% of interviewees choose the option of automatic generation, as shown in Figure 4-4-(a). In fact, from the questionnaire, the automatic method is the trend of machining without consideration of the simplest part of the product, as the tool path of simplest part was generated manually. Figure 4-4-(c) illustrates the advantages of CAM software. There is no doubt that using CAM system can reduce the time cycle of tool path generation, most interviewees choose “high efficiency” as the most important advantage.

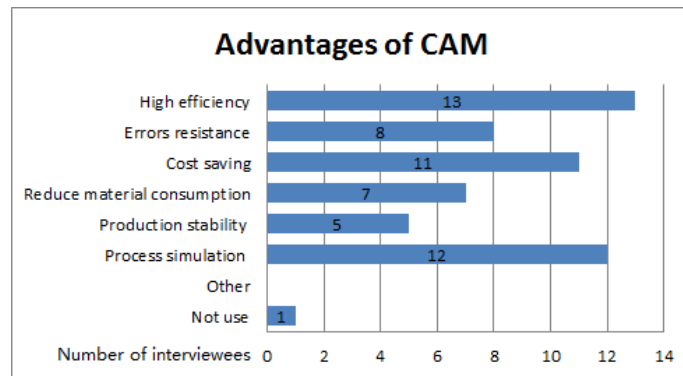
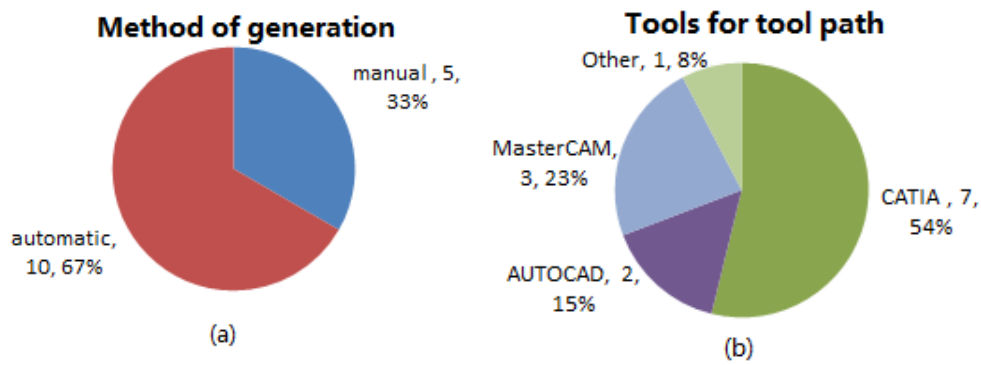

(c)

Figure 4-4 Method and tools for tool path generation

There is much software available for tool path generation. Because COMAC is an aircraft manufacturing company, whose official CAD software is CATIA, most interviewees chose CATIA. Different industries may use different software for different purposes. In general, there is mainstream software in the same industry. For example, CATIA is used in the aviation Industry while UG is predominantly used in the automotive industry.

4.4.2.2 Machine and Material

Two questions were designed to identify the commonly used machine and materials in the interviewees' companies. Fourteen interviewees mentioned the milling machine to be widely used and over 70% of interviewees used typically aluminum and steel, as illustrated in Figure 4-5. In fact, because of the widely used of milling machine, this research choose it as research object.

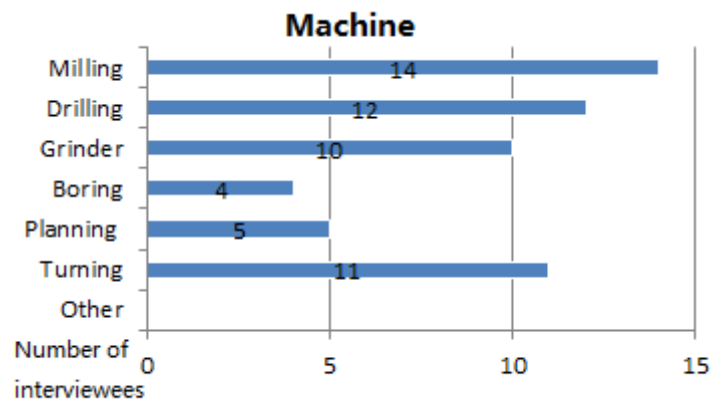

(a)

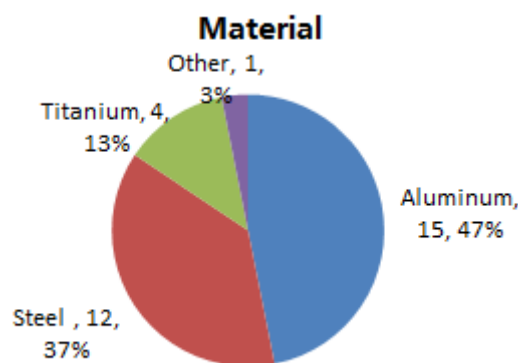

(b)

Figure 4-5 Common machines and materials

4.4.2.3 Procedure of Tool Path Generation

According to the answers to the question “which are the essential stages of manufacturing”, the manufacturing procedure can be presented as shown in Figure 4-6.

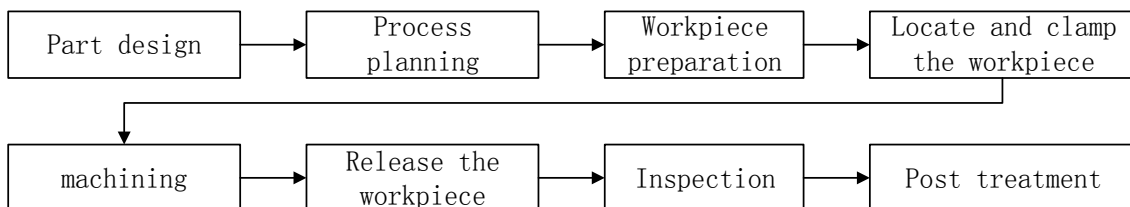

Figure 4-6 Procedure of machining

Workpiece preparation includes process planning and pre-treatment when necessary. For a 4-side pocket milling in Figure 4-7, it cannot begin until the auxiliary hole is finished prior to milling which can facilitate easy cutting.

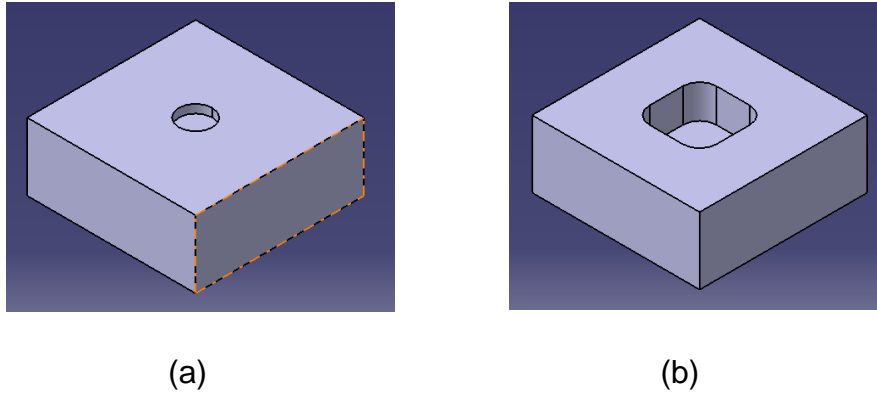

Figure 4-7 Auxiliary hole (a) for a 4-side pocket (b)

After preparation, it is essential to locate and clamp the workpiece accurately and tightly to ensure the result of manufacturing. However, several interviewees provide some comments about machining. Machining usually contains three sections: roughing, semi-finishing and finishing, as shown in Figure 4-8. In general, roughing and finishing are enough to operate. All three sections have the tool path, which can generate by requirements

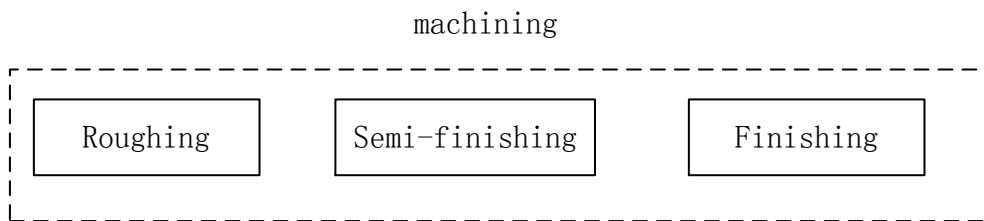

Figure 4-8 Steps of machining

According to the answers of the question “which are the essential stages are of tool path generation”, the tool path generation procedure can be illustrated as shown in Figure 4-9. Model and geometry is fundamental to the whole process as it determines whether the workpiece should be operated by a milling machine. Once the process planners ensure the manufacturing process, the machine, tool and path can be chosen as well as the parameter modification. Then, the tool path can be generated. The generated tool path can be simulated if necessary. Always, post processor is necessary because some tool paths, which are generated by commercial software, cannot be used directly with CNC machine.

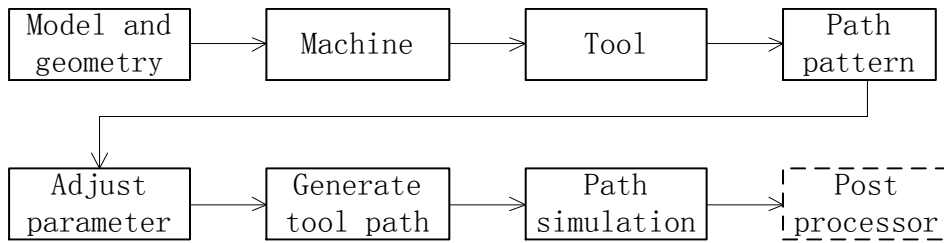

Figure 4-9 Procedure of tool path generation

4.4.2.4 Factors of Tool Path Generation

As illustrated in Section 2.3.4, there are several factors that should be considered in the procedure of tool path generation. Figure 4-10 shows the results of the questionnaire related to this issue. Significantly, the questionnaire illustrated that among these factors, the tool is the most important factor. Certainly, tool path, material and speed rate are also important. Two interviewees suggested that the speed rate can be divided into two: the cutting speed and the spindle speed.

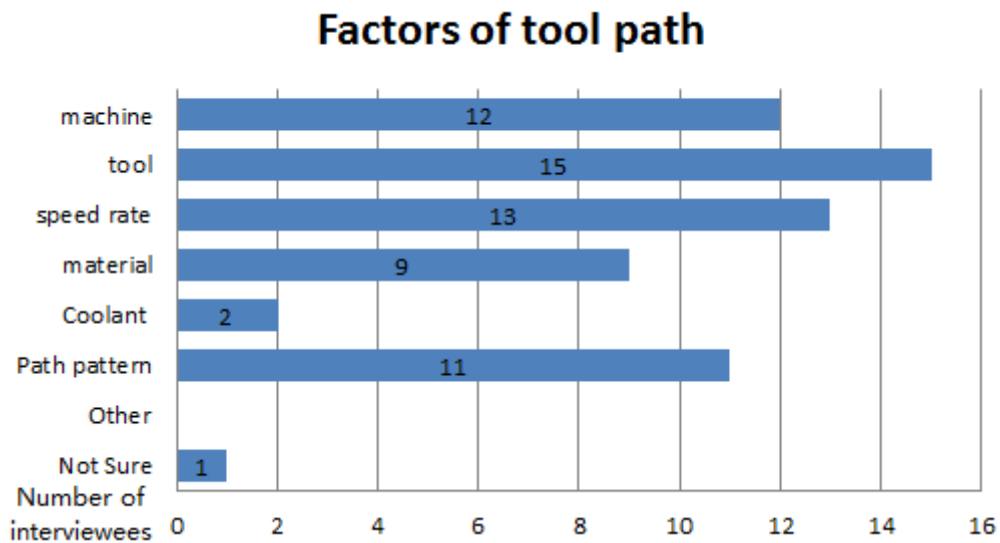

Figure 4-10 Factors of tool path generation

(1) Tool

Milling tool selection is an important issue in the procedure of tool path generation, which not only affects the efficiency of machining, but also directly the quality of product (Zhou et al., 2013) .

From the literature, milling cutters can be divided into many types. Different cutters will be used in different situations. For example, end mill can be used for milling planes, grooves, contours and so on, while metal slitting saw only can be used for slot milling or metal cutting.

However, from the semi-structured interviews, not all types of cutters may be available or used in all companies. Only some common cutters can be used because of the cost. From the questionnaire and semi-structured interviews, different cutters may be available in different occasions. In the choice of cutter dimension, there are also some requirements. For example, for a 4-side pocket in Figure 4-7, the radius of the corner is 5mm; theoretically, the dimension of the cutter cannot exceed 5mm. If the design requirement is much higher, the dimension of the cutter should be smaller than 5mm. The smaller the cutter dimension chosen, the more accurate will be the product.

(2) Tool path pattern

The paths of a cutter also have several typical patterns, such as zigzag, parallel spiral, and one way for facing and pocket milling.

When generating a tool path, the engineer can choose different path patterns, which are also suitable for different features. Different tool path patterns may result in varying accuracy of products. There is a basic rule for tool path, namely keep the cutter constantly engaged, as shown in Figure 4-11. For example, if there are two methods for facing, the second one should be chosen.

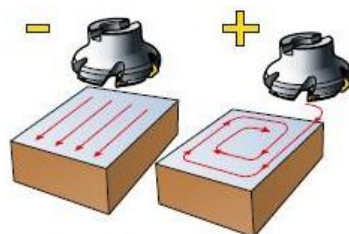

Figure 4-11 Keep cutter constantly engaged (SANDVIK Coromant, 2013)

(3) Material

Many materials can be used for milling, such as aluminium, steel, cast iron, copper and so on. Over 70% of interviewees used aluminium and steel, as illustrated in Figure 4-5-(b).

(4) Speed

Cutting speed is closely related with materials, tools and other factors. The formula is shown as follows.

Cutting speed (m/min):

$$V_C = \frac{D_{cap} \times \Pi \times n}{1000} \text{ (SANDVIK Coromant, 2013)}$$

Where,

D_{cap} (mm), Cutting diameter at actual depth

n (rpm), Spindle speed

Π , Pi

The common cutting speed for different material was shown in Figure 4-12

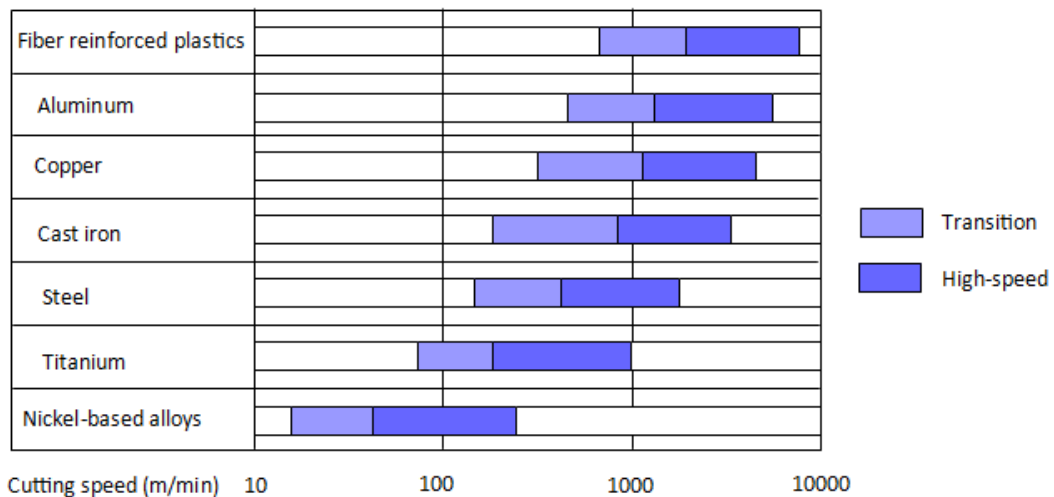

Figure 4-12 Cutting speed with material (Boothroyd and Knight, 2006)

(5) Machine

As illustrated in Figure 4-5-(a), the milling machine was the most common machine cited in the interview. Certainly, it comes in different types. Table 4-2 gives the example of common milling machine as well as comments.

Table 4-2 Examples of milling machine

Classification	Type	Comments
Milling with lift	Include universal, horizontal and vertical	Mainly used for medium and small parts, the most widely used.
gantry	including gantry milling and boring machine, double column milling machines	Used for machining large parts.

4.4.2.5 Manufacturing Features

The aim of the question “which are the usual manufacturing features” is to find the most common milling features on the shop floor. As illustrated in Figure 4-13, facing, 4-side pocket, blind slot, through slot as well as hole are used frequently.

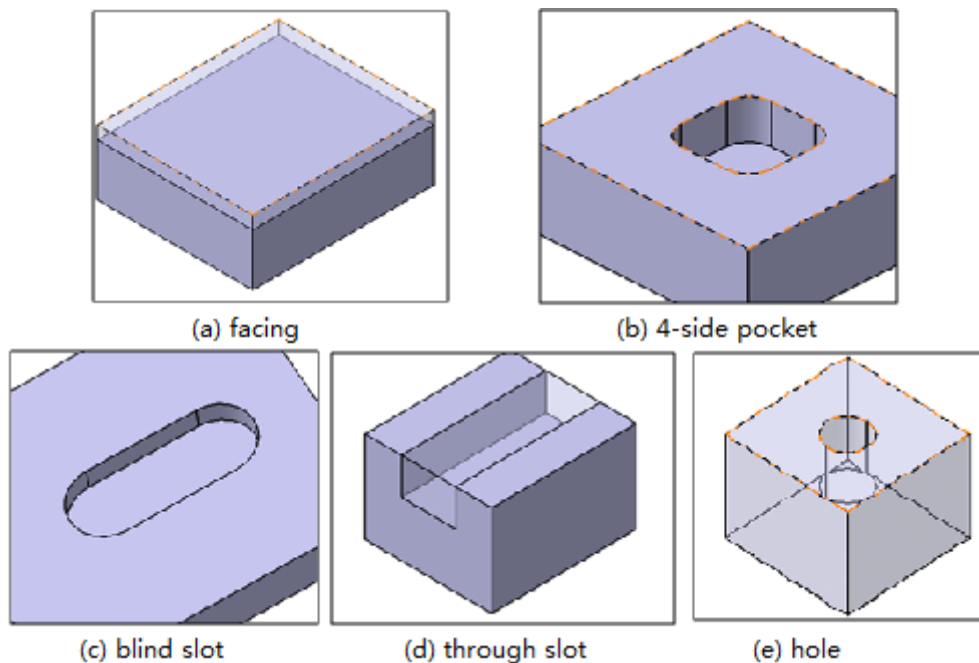

Figure 4-13 Common features

4.4.3 Capturing Tool Path Process Capabilities

Most interviewees mentioned that it is necessary to capture the tool path process capabilities. The question “what are the most important benefits of capturing the tool path process capability” is to identify the advantages of capturing knowledge of tool path generation. The results are illustrated in Figure 4-14, in which, ensuring and promoting tool path capability is the greatest benefit.

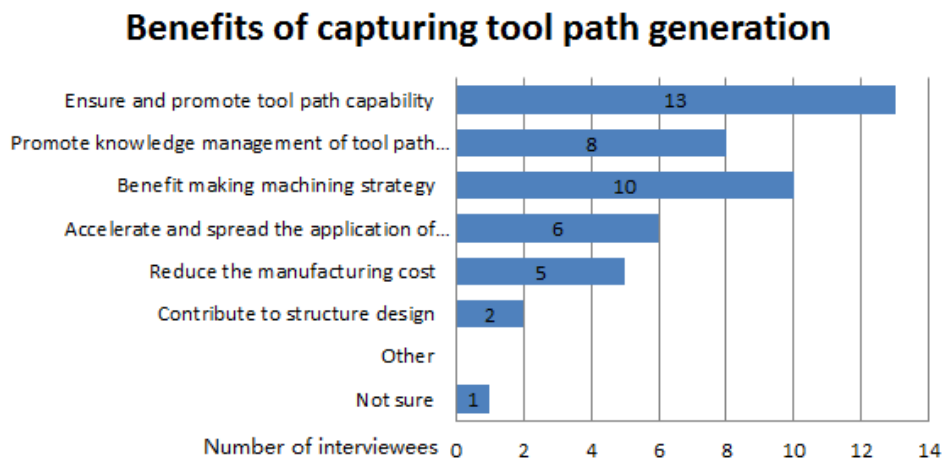

Figure 4-14 Benefits of capture tool path generation

Another question was designed to find the difficulties in the process of capturing tool path generation. Figure 4-15 shows the results, in which, not enough statistics from application is the most significant.

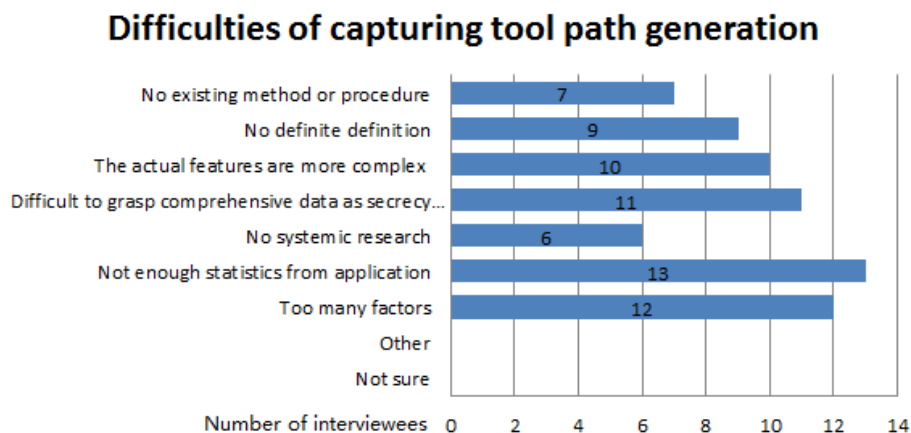

Figure 4-15 Difficulties of capturing tool path generation

4.5 Summary

Based on the collected data and results from the questionnaire, semi-structured interviews and literature review, all the information about CNC tool path generation are identified, i.e. the procedure, the factors, tool or mode of generation. Furthermore, the information about how the factors may affect the CNC tool path as well as how to improve the performance through controlling the factors is also collected. Based on that information, an IDEF0 map including all of this information can be built, which is described in chapter 5.

5 KNOWLEDGE MODEL DEVELOPMENT

5.1 Introduction

A knowledge model for tool path generation in machining is developed in this chapter, based on identified factors from the literature review and acquired data in Chapter 4. This chapter presents how the knowledge model is built and what it contains. Figure 5-1 shows the development flow diagram of tool path generation.

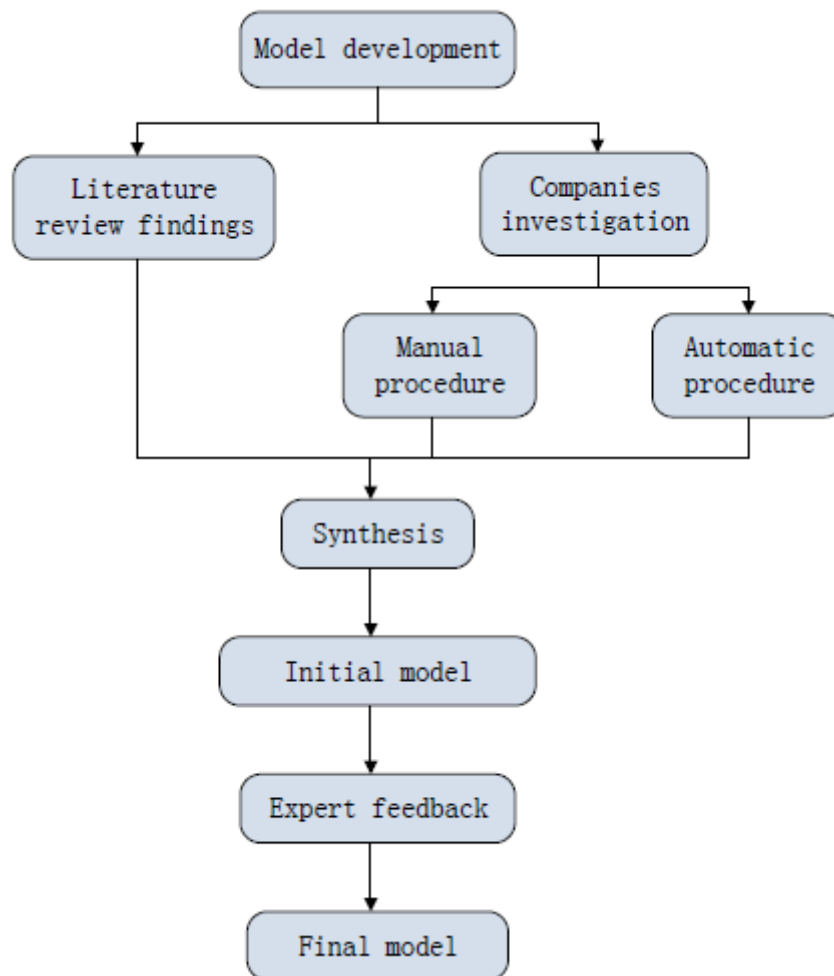

Figure 5-1 Flow diagram of model development

5.2 Literature Review Findings

Figure 5-2 illustrates critical factors influencing tool path generation, for example, tool, speed, machine, material, path pattern. Matching the results from the

questionnaire, the tool and path pattern are deemed the most important factors. Hence the suggested focus of this research are these significant factors (Zhou et al., 2013; Rauch et al., 2009; El-Midany et al., 1993; Smith and Dvorak, 1998; Arezoo et al., 2000; Ge et al., 2013; Lartigue et al., 2003; Yao et al., 2013; Shan et al., 2013; Hsu et al., 2007; Choy and Chan, 2003; Senatore et al., 2012).

Key aspects Authors	Tool	Speed	Machine	Material	Path pattern	Temperature
Zhou et al. (2013)	✓					
VRauch et al. (2009)					✓	
El-Midany et al. (1993)	✓		✓		✓	
Smith and Dvorak (1998)		✓		✓	✓	
Arezoo et.al (2000)	✓					
Ge et al. (2013)						✓
Lartigue et.al (2003)	✓		✓			
Yao et al. (2013)		✓		✓		
Shan et.al (2013)	✓			✓		
Hsu et.al (2007)		✓		✓		✓
Choy and Chan (2003)					✓	
Senatore et.al (2012)	✓		✓			
total	6	3	3	4	4	2

Figure 5-2 Findings from literature

5.3 Investigation Results

5.3.1 Data Analysis Results

The results of the data collection and information in chapter 4 present problems to some manufacturing companies. They are summarised in Table 5-1.

Table 5-1 Problems found in information collection

Problem 1	Different process planners have different ideas.
Problem 2	Regarding to tool path generation knowledge, there are no regulated methods to capture, represent and share it.

5.3.2 IDEF0 Map for Tool Path Generation

Figure 5-3 presents an initial flowchart of a tool path generation procedure. It begins with the model and requirements of the part or product and ends when the CNC file was developed.

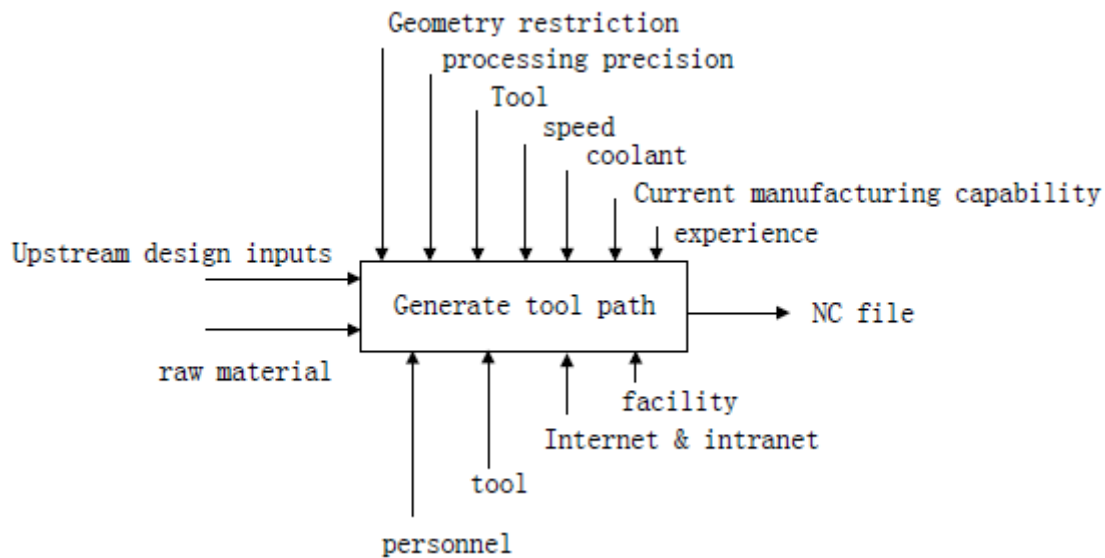

Figure 5-3 Initial IDEF0 map of tool path generation

The main inputs of tool path generation include upstream design inputs, including surface geometry, geometric tolerance and other design requirements, and raw materials, whilst the outputs is the CNC file, which can be recognised by the machine controller. Both control and mechanism are considered in this procedure, including geometry restriction, processing precision, personnel, etc.

However, from the results of interviews, employees cannot follow a clear flow to decide the final tool path which means that process planning engineers and manufacturing engineers cannot make a decision step by step. This illustrates problem 2 in Table 5-1. Therefore, it is necessary to build an efficient work environment to identify every step of tool path generation.

The final IDEF0 map of tool path generation is presented in Figure 5-4. It shows that a tool path is not a separate process. It is related to upstream and downstream processes such as process planning, simulation and quality check. It can be seen from this map that the output of models- O1 (3D model) and O2

(2D drawings) are the inputs of the process planning. In every step, the input, output, control and mechanism are identified. This classification helps show the information and knowledge flow in tool path generation, which also helps to identify rules and recommendations in this procedure.

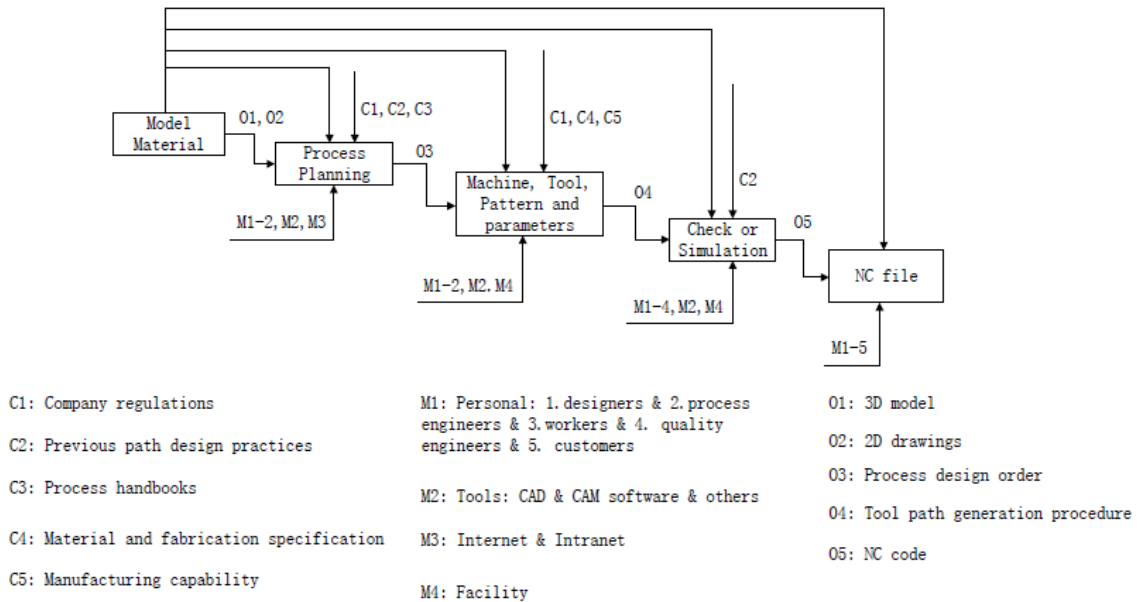

Figure 5-4 Final IDEF0 map of tool path generation

5.4 Knowledge Capture

5.4.1 Rules and Recommendations

Rules check whether the procedure and parameters of tool path generation are available. The condition (“IF”) and statement (“THEN”) comprise a complete rule, as shown in Figure 5-5 (Sun, 2011).

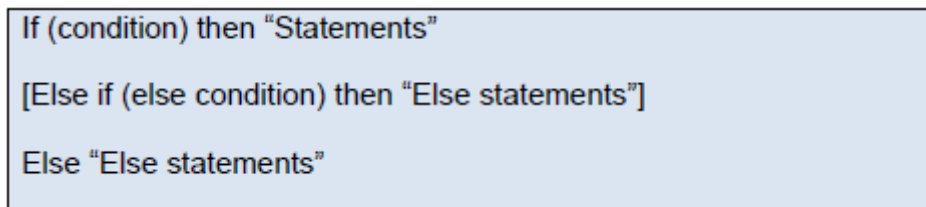

Figure 5-5 Structure of rules (Sun, 2011)

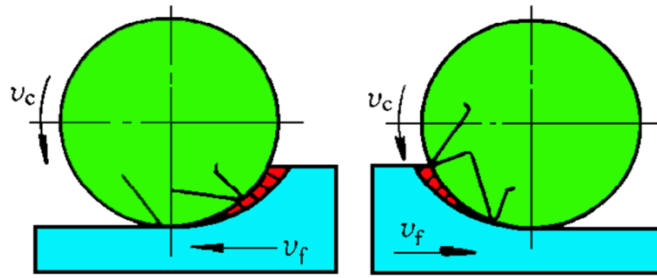

Figure 5-7 Conventional and Climb

5.4.2.2 Factors

(1) Tool Type

Type	Category	Application
Cutter for plane	Cylindrical cutter, including coarse teeth, fine teeth	Roughing and semi-finishing plane
	Face milling cutter	Roughing, semi-finishing and finishing plane
Cutter for groove, steeped	End mill, including coarse teeth, medium teeth, fine teeth, shell and die milling cutter	Groove surface; roughing and semi-finishing plane, stepped and mold surface
	Face and side cutter	Roughing, semi-finishing and finishing groove surface
	Saw-tooth milling cutter, including coarse teeth, medium teeth, fine teeth	Machining narrow groove surface; cutting off
	Screw slotting cutter	Cut the head of screw
	Slot mill, including flat keyway cutter and woodruff keyway milling cutter	Surface of flat keyway; woodruff keyway
	T-slot cutter	Surface of T-slot
	Dovetail cutter	Surface of Dovetail
Cutter for curve	Angular cutter	Groove surface with angular ($18^\circ - 90^\circ$)
	Including convex cutter, concave cutter, pinion type cutter	Convex and concave surface and curve

(2) Tool Selection

In the machining process, it is necessary to arrange the order of the tool. Generally, it should follow several principles: ①The number of tools should be minimised; ②The steps which can be completed should be achieved in one tool clamping; ③ The tools of roughing and finishing should be considered separately, even if they have the same sizes.

(3) Tool Geometry

① When facing by one pass, the recommended tool diameter is $W^{4/3}$. W is the width of face.

② When milling in corners, tool radius cannot exceed $2 * \text{fillet radius (R)}$. The recommended tool radius is $1.5 * \text{fillet radius (R)}$ when roughing while $0.8 * \text{fillet radius (R)}$ when finishing.

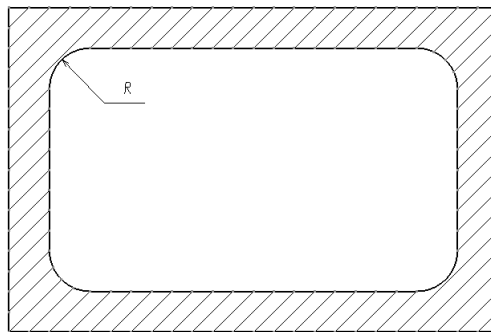

Figure 5-8 Radius of tool

(4) Path pattern

a. Avoid tool idling.

Keeping cutter constantly engaged makes high efficiency and protects the tool. In Figure 5-9, the recommended pattern is (b).

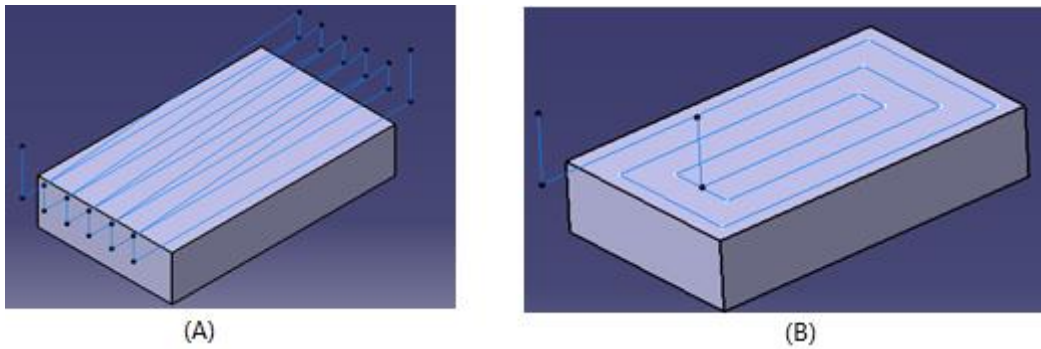

Figure 5-9 Avoid tool idling

b. Zigzag Optimization

In the face milling, based on the principle of avoiding tool idling, the zigzag pattern can be optimization, as shown in Figure 5-10.

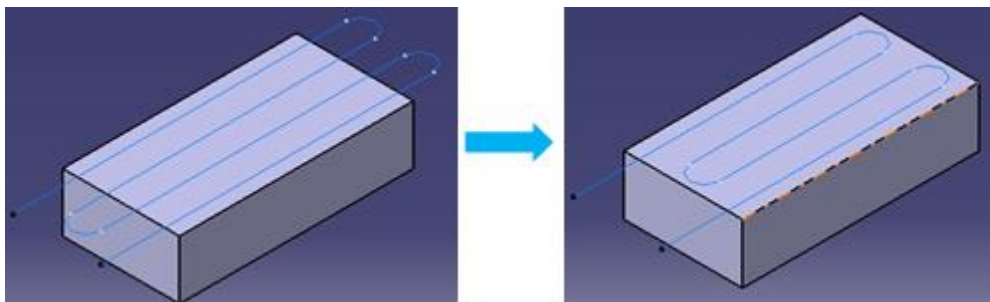

Figure 5-10 Zigzag optimization

(5) Cutting speed and material

a. v_c

For ball nose end mills in Figure 5-11, the formulas were given.

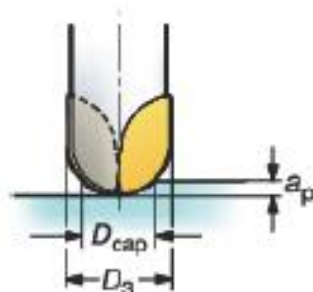

Figure 5-11 Ball nose end mill

$$v_c = \frac{D_{cap} \times \Pi \times n}{1000}$$

$$D_{cap} = \sqrt{D_3^2 - (D_3 - 2 \times a_p)^2}$$

Where: D_3 - diameter of the cutter

If ($a_p \uparrow$ and n keep constant) then $v_c \uparrow$

Else if ($n \uparrow$ and a_p keep constant) then $v_c \uparrow$

Comments: In the premise of quality assurance process, taking into account the necessary productivity, choose the right a_p by machining allowance and n by surface quality requirements, then ensure V_c as large as possible with the consideration of tool durability and the quality of the surface.

b. Material

Different materials mean different characteristics. The cutting speed also depends on the material. Figure 5-12 shows the conventional speed, transition speed and high speed of several materials.

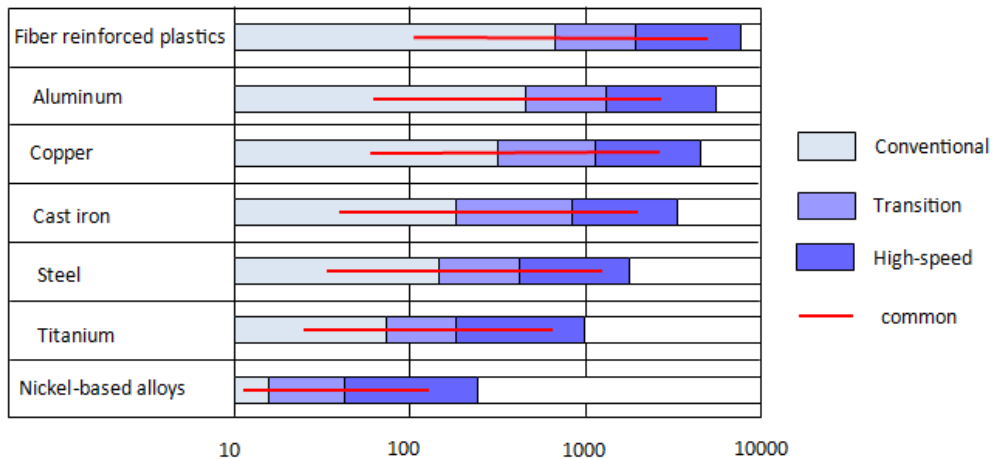

Figure 5-12 Cutting speed of different material (Unit:m/min)

(6) Stepover and stepdown

a. Stepover

$$H_s = D_c - H_a$$

H_a : Overlap of two passes;

H_s : Stepover of two passes.

D_c : Diameter of cutter

The recommended H_a is $25\% \times D_c$. In the Figure 5-13, the green lines represent the edge of part while the blue lines represent the paths.

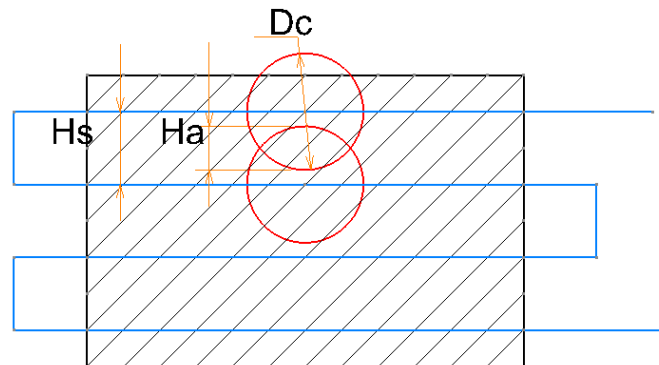

Figure 5-13 Example of stepover

(2) Stepdown

The step of cutting depth depends on the workpiece material, cutter material, and cut speed and so on. In general, the recommended values were shown in Table 5-2.

Table 5-2 The recommended cutting depth

Occasion	Procedure	Stepdown
plane	roughing	25% of tool flute.
	finishing	50% of tool flute.
profile	roughing	20% of tool flute.
	finishing	40% of tool flute.

(7)Cutting fluid

Table 5-3 Cutting fluid comments

Material	Comments
Aluminium	Unlike most other milling applications, cutting fluid should always be used in aluminium to avoid smearing on the insert edges and to improve surface finish.
Steel	Always milling without cutting fluid especially in roughing process. In finishing, cutting fluid, or preferably mist coolant/minimal lubrication, is sometimes necessary to improve the surface finish.
Cast iron	Preferably run dry, without cutting fluid, to minimize problems with thermal cracks.
Titanium	Unlike milling in most other materials, coolant is always recommended to assist in chip removal, to control heat at the cutting edge,

5.4.2.3 Milling features

(1) Facing

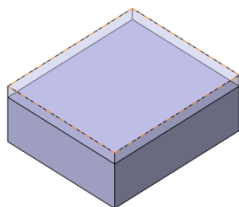

Parameters for function blocks

Origin(X,Y,Z)

Dimensions (length, width, height)

T (tool diameter, tool flute)

CHeight (cutting height)

Feed, Speed. Retract

**Pattern
comments**

and

If roughing, then choose one way or parallel spiral
If finishing, then choose zigzag or zigzag with

loop(high speed milling)

Comments:

One way: reduce milling force, less efficiency

Parallel spiral: protect tool, bad surface roughness

Zigzag: high efficiency

Zigzag with loop: high efficiency, prevent the tool pauses and tremor

(2) 4-side pocket

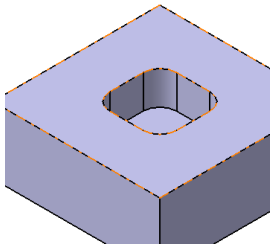

Parameters for function blocks

Origin(X,Y,Z)

Dimensions (length, width, fillet)

T (tool diameter, tool flute)

CHeight (cutting height)

Feed, Speed. Retract

**Pattern
comments**

and

If roughing, then choose zigzag or parallel spiral

If finishing, then choose parallel spiral or one way

Comments:

Zigzag: high efficiency, bad surface roughness

Parallel spiral:

One way: low efficiency

(3) Hole

Parameters for function blocks

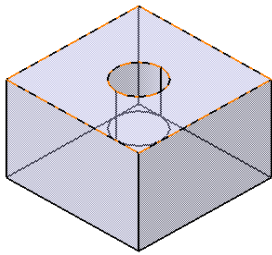

Origin(X,Y,Z)

Dimensions (radius, height.)

T (tool diameter, tool flute)

CHeight (cutting height)

Feed, Speed. Retract

Pattern and comments

One pass

Comments:

Tool diameter is as same as hole diameter

(4)Thru slot

Parameters for function blocks

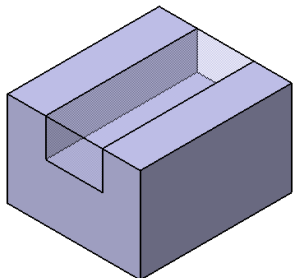

Origin(X,Y,Z)

Dimensions (length, width)

T (tool diameter, tool flute)

CHeight (cutting height)

Feed, Speed. Retract

Pattern and comments

If for roughing, then choose trochoidal strategy

If for finishing, then choose one way (two sides)

Comments:

Trochoidal strategy is special suitable for difficult machining material with high feed and high speed.

(5)Blind Slot

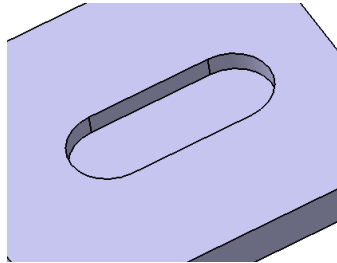

Parameters for function blocks

Origin(X,Y,Z)

Dimensions (length, width, fillet)

T (tool diameter, tool flute)

CHeight (cutting height)

Feed, Speed. Retract

**Pattern
and
comments**

and

If for roughing, then choose layered milling, cut obliquely between layers

If for finishing, choose parallel spiral

5.4.3 Key Rules Selection

As the developed rules and recommendations are categorised as general, factors, i.e. tool, machine and machining features, the selected key rules, should cover all these domains. According to the different number of developed rules and recommendations in these three domains, four key rules were selected as representatives, as shown in Figure 5-14.

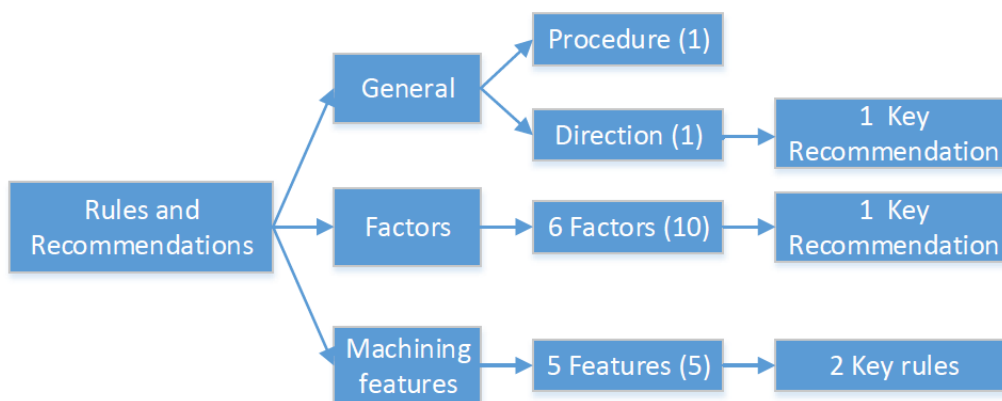

Figure 5-14 Distribution of rules and selection of key rules

Note: (10) represents 10 rules or recommendations

Regarding general rules and recommendations of CNC tool path generation, there are two basic rules about procedure and cutting direction. It is well known that the procedure of CNC tool path was comprised with three steps from the semi-structured interview while the direction is not well known. However, the direction can greatly affect some materials (Vivancos et al., 2004). As a result, one key rule about cutting direction was chosen.

Based on the questionnaire and literature, six factors such as tool and common machining features were identified. Among the factors, the tool is the most important one, as illustrated in Chapter 4.4.2.4. Thus one key rule relate to tools was selected. Machining features are the main research focus. Among all machining features, facing and 4-side pocket were considered as representative. Therefore, two key rules about facing and 4-side pocket as well as path patterns were selected.

The selected key rules and recommendations are demonstrated in Chapter 5.4.4.

5.4.4 Knowledge Representation

The four key rules selected are discussed in this section. The effect of cutting direction was demonstrated through the literature; the effect of tool selection and path pattern were demonstrated through case study; and the effect of path pattern for machining features was demonstrated through case studies and expert results from semi-structured interviews in COMAC.

5.4.4.1 General Direction Recommendation - Effect of Cutting Direction

 **The recommended cutting direction for Roughing, especially for workpieces with a rough initial surface, such as forged components, is Conventional while climb direction should be used for finishing.**

As the selection of cutting direction is the first issue to be decided for tool path generation, it has been chosen as a key recommendation. Climb milling is

characterised by the fact that the direction of cut and rotation of the cutter are the same while for conventional milling the opposite is true.

This recommendation is demonstrated by the information collected from the semi-structured interviews. With conventional milling, the tooth meets the workpiece at the bottom of the cut and creates an upward force to lift the workpiece, so more power is required for conventional milling than climb milling and the surface finish is typically worse (Brezocnik et al., 2004). The situation is different for climb milling. The tooth meets the workpiece at the top of cut and exerts a down force, which makes workholding and fixtures simpler, so less power is required and surface finish is improved. The force of conventional and climb milling are illustrated in Figure 5-15. Vivancos et al. (2004) studied the influence of the cutting direction in high speed milling of hardened steels for injection moulds; it was discovered that climb machining leads to better surface roughness than conventional machining.

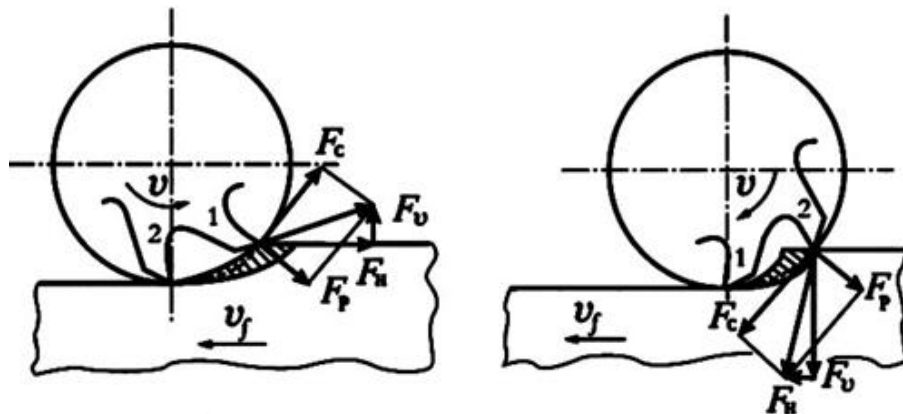

Figure 5-15 Force of different direction (Changchun University of Science and Technology, 2012)

5.4.4.2 Factor Recommendation - Effect of Tool Selection

In the machining process, it is necessary to arrange the order of the tool. Generally, it should follow several principles: ①The number of tools should be minimised; ②The steps which can be completed should be achieved in one tool clamping. ③The tools of roughing and finishing should be considered separately, even if they have the same sizes.

As the tool is the most important factor in the process of tool path generation, the recommendation of tool selection is chosen as a key recommendation. It is demonstrated by the information collected through semi-structured interviews. A tool path sequence for a sample design was examined to test this recommendation through the milling simulation software NCspeed (Formtec GmbH).

The recommendation ② is used to illustrate the importance of tool selection. To complete all the steps which can be completed in one tool clamping implies minimising the change of tool in the machining procedure, which will reduce the time of cutting air with no feed.

Figure 5-16 shows the example with several features, i.e. sunk hole, pocket as well as facing. Figure 5-17 presents the process of the interviewee, in which, sunk hole 1 and sunk hole 2 are completed in sequence. In addition, although pocket 1 and pocket 2 are completed with the same tool, they are operated separately. With the consideration of rules for tool selection, pocket 2 should be followed by pocket 1, the top of sunk hole 2 should be followed with the top of sunk hole 1 and then drill the bottom of the two sunk hole, as shown in Figure 5-18. The result of the simulation was shown in Table 5-4. Obviously, the time of the recommended process (Figure 5-18) is less than that from the interviewee (Figure 5-17).

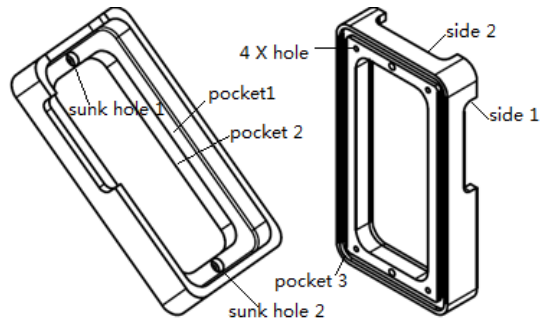

Figure 5-16 Example of part

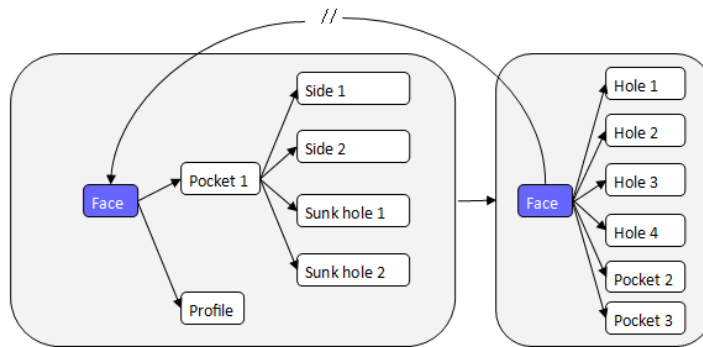

Figure 5-17 Process from interviewee

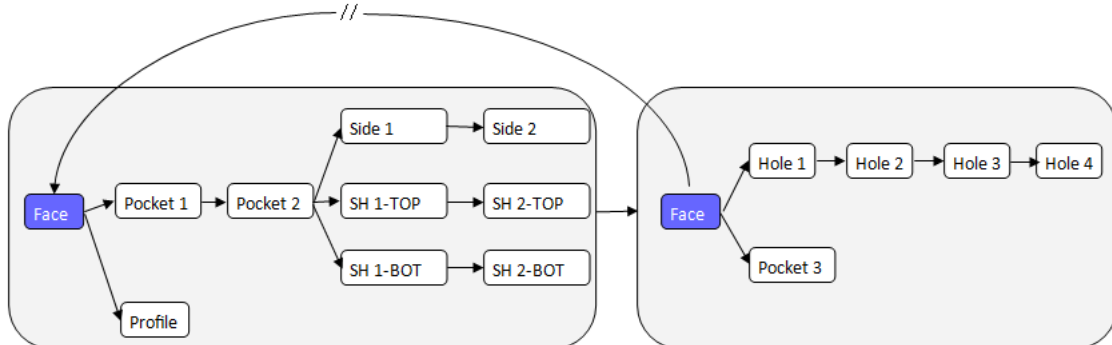

Figure 5-18 Recommend process

Table 5-4 Comparison of two process

	Process from interviewee	Recommend process
Number of tool	9	9
Changes of tool	12	10
Time determined through NCspeed	12:04min	11:13min

5.4.4.3 Feature Rule - Facing

The recommended path pattern for facing is:

If roughing, then choose one way or parallel spiral

If finishing, then choose zigzag or zigzag with loop (high speed milling)

From the interview results and literature, facing is the most common feature in machining. This rule has been created through information collected from the semi-structured interviews. At least four patterns can be used for face milling. These are: one pass, one way, zigzag, parallel spiral.

One pass: the tool cuts the face once along the target direction. This pattern only suits small or medium parts because the size of tool for one pass must over the width of the part.

One way: the tool cuts always following the same target direction. In this way, the tool keeps cutting in conventional milling or climb milling, which will help to ensure uniform forces and stability during the milling process. However, due to increased time for lifting tool while the tool is cutting air, the milling efficiency is low.

Zigzag: the tool cuts back and forth changing the cutting direction 180° after each pass. In this procedure, the tool keep milling without lifting, thus the efficiency is higher. However, conventional milling and climb milling which were conducted alternately impact the quality of the surface. Zigzag with loop is similar with zigzag. The difference is in the corner. Zigzag represents 90° in the corner while zigzag with loop represents and arc. This milling pattern is suitable for high speed milling (Rangarajan and Dornfeld, 2004).

Parallel spiral: the tool cuts from the inside to outside, or outside to inside following a spiral pattern with line. In certain circumstances, this pattern leaves over corner to clean, so it is better to use in the roughing stage. On the other hand, the tool which cuts in and cuts out the part once respectively suffers less

force in the edge compared with one way and zigzag. As a result, this pattern was preferred when milling large planar surfaces.

In summary, the recommended patterns for roughing is one way or parallel spiral while the recommended patterns for finishing is zigzag.

5.4.4.4 Feature Rule - 4-side Pocket

The recommended path pattern for 4-side pocket is:

If roughing, then choose zigzag or parallel spiral

If finishing, then choose parallel spiral or one way

For the same machining features, different tool path patterns may result in different surfaces. This rule is demonstrated by the information collected from the semi-structured interviews and CAM software simulations. For a 4-side pocket, Figure 5-19 illustrated four common path patterns, namely: one way, zigzag, parallel spiral and true spiral. The definition of one way, zigzag and parallel spiral was illustrated in chapter 5.4.4.3. The true spiral is the tool cuts from the inside to outside, or outside to inside following a spiral pattern with arc. For a 4-side pocket, if the width and length are not the same, the arc of spiral will not be continuous. As a result, this pattern may increase the time of cutting air.

Table 5-5 illustrated the common path patterns simulation results as well as the comparison. As illustration, to complete the same size 4-side pocket, zigzag is the fastest pattern; one way, zigzag and true spiral makes burr while parallel spiral does not. Among these four patterns, one way creates the best surface finishing.

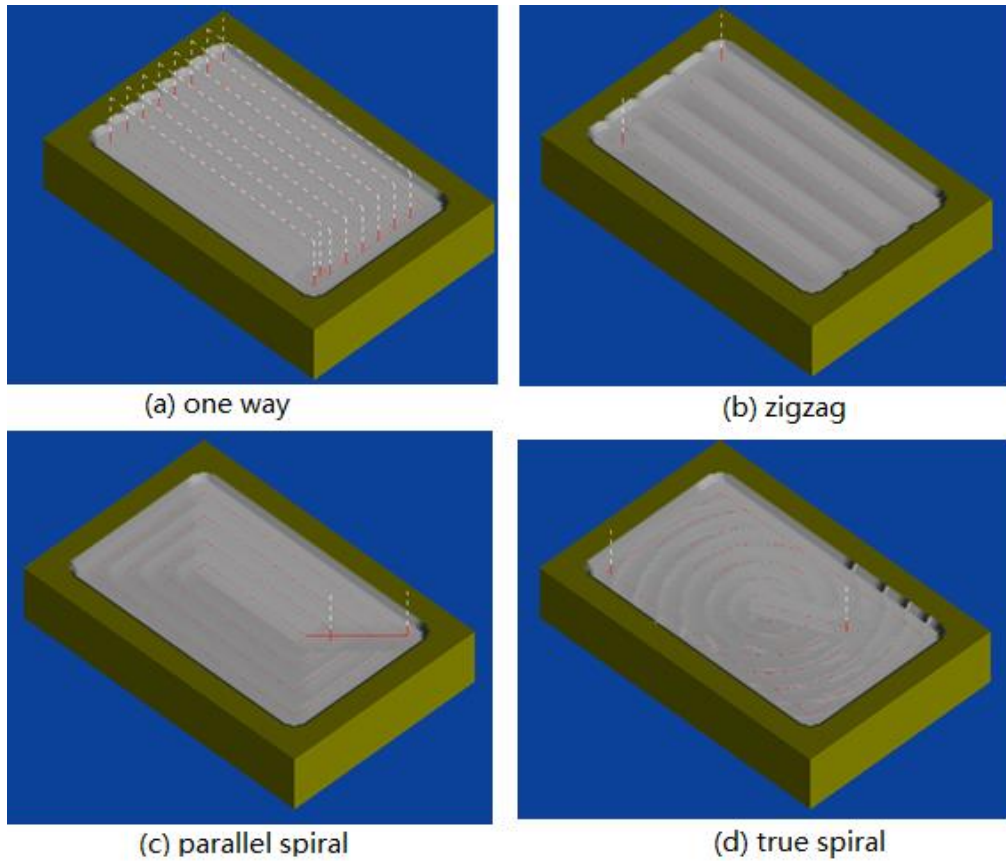

Figure 5-19 Four path pattern of 4-side pocket

Table 5-5 Comparison of different path patterns

Properties	One way	Zigzag	Parallel spiral	True spirial
Time	2:22min	2:11min	2:15min	3:41min
Burr	√	√		√
surface	high	medium	medium	medium

Considering the above factors, the recommended patterns for roughing are zigzag or parallel spiral while the recommended patterns for finishing is parallel spiral or one way.

5.5 Summary

In this chapter, the model development procedure of CNC tool paths was first presented. Based on the literature review findings and investigation results, an IDEF0 map for the process of CNC tool path generation was developed, which

is useful for emulator selection and development of rules and recommendations. The rules and recommendations were then captured for the process and considerations during the procedure. Finally, four key rules and recommendations were selected to demonstrate the final knowledge representation.

6 VALIDATION OF KEY RULES

6.1 Introduction

This chapter introduces the key rules validation process. All the developed rules and recommendations were validated through expert judgment and two key rules were selected for case study. The structure of this chapter is as follows: Section 6.2 introduces the validation process; Section 6.3 and 6.4 introduce the validation through case study and expert judgment for the key rules; finally, Section 6.5 presents the summary of this chapter.

6.2 Validation Process

Three steps were used in the validation process, as shown in Figure 6-1. First, two key rules were chosen from the developed rules and recommendations. Secondly, the methodology of case studies was used to demonstrate the selected key rules. Finally, the key rules were validated through expert judgment. This included two stages, namely initial judgment, whose aim was to check correctness of developed rules and final judgment, whose aim was to identify the usefulness and weakness of the rules.

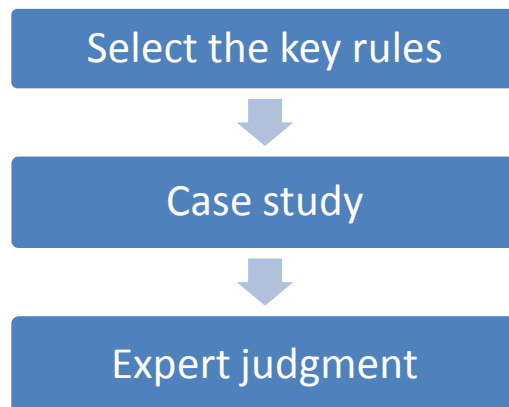

Figure 6-1 Validation process

The author invited two independent experts from Cranfield University and COMAC, to validate the initial rules and recommendations and share comments which could be added in for refinement. Both experts have rich experience of tool path generation. Table 6-1 gives a brief introduction to the two independent

experts. In the process of expert judgment, both a face-to-face interview and questionnaire were conducted. Firstly, a presentation of this research was conducted for expert A as well as the developed rules and recommendations. The expert checked the key rules and thoroughly discussed with the researcher. After the discussion, comments were given for the selected key rules and recorded in the questionnaire. As expert B is in China, it was impossible to conduct face-to-face interview. Therefore, a questionnaire was emailed to expert B for their judgment. A brief introduction to this project and the selected key rules were also sent to the expert by email along with the questionnaire.

Table 6-1 Introduction of experts for validation

Expert	A (from CU)	B (from COMAC)
Position	Research fellow on CAPP-4-SMEs	Director of NC workshop
Experience	Over four years' experience on machining	Over 7 years' experience on machining
Validation method	Structured interview	Questionnaire

6.3 Case Study (remove blank)

6.3.1 Application of One Key Recommendation

✚ The recommended cutting direction for Roughing, especially for workpieces with a rough initial surface, such as forged components, is Conventional while climb direction should be used for finishing.

Figure 6-2 Case study – key recommendation 1

The key recommendation about cutting direction, which is simple but very important, has been chosen to demonstrate knowledge modelling, knowledge representations and its practical application in Function Blocks. The key

recommendation was shown in Figure 6-2. The aim of this case study is to show the characteristic of event-driven as well as value input and output

6.3.1.1 Software Adopted

To generate CNC tool paths for FBs, the first step is to choose a suitable tool, which is essential in IDEF0 map (Figure 5-4). Both FBDK (Function Block Development Kit) and 4DIAC (Framework for Distributed Industrial Automation and Control) can be used to build basic and composite Function Blocks. Much research uses FBDK as basic and initial software tool. Furthermore, compared with 4DIAC, the interface of FBDK is much simpler and easier to operate. In this research, the software tool was used for virtual simulation, whose main aim is to verify the possibility of implementing FBs with developed rules and recommendations. However, the developed models by FBDK for FBs can also be used in 4DIAC. Hence, the adopted software is FBDK.

6.3.1.2 Function Block Design

To demonstrate the two different cutting directions, two different events must be defined, as shown in Figure 6-3, i.e. conventional and climb. The two events are related with the same data input. In this basic Function Block, four data, namely Origin, Dimensions, T, CHeight are set. The “Origin” means the position of the top centre of the part. The “Dimensions” is the length, width and height of the part, which is defined through an array. The “T” represents the diameter and flute of the tool and the “CHeight” is the cutting height.

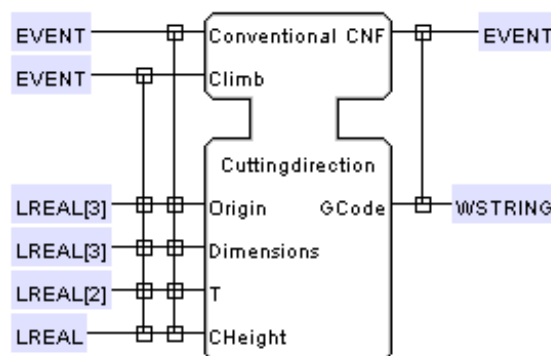

Figure 6-3 Function Block design

For the execution control design, both of the events have their algorithms as demonstrated in Figure 6-4. When the event “Conventional” is triggered, the algorithm “Conventional” is available and operates. The “Conventional” algorithm design is shown in Figure 6-5, which is programmed by XML language.

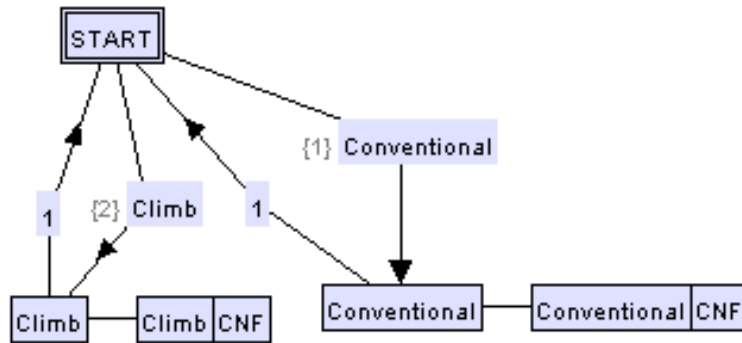

Figure 6-4 ECC design

```

<Algorithm Name="Conventional" Comment="Normally executed algorithm" >
  <Other Language="Java" Text="
  L1.value=((LREAL)Dimensions.value[0]).value;
  W1.value=((LREAL)Dimensions.value[1]).value;
  Passxy.value=Math.ceil((W1.value/ ((LREAL)T.value[0]).value));
  GCode.value=&#34;G20; &#34;;
  GCode.value=GCode.value + &#34;G0 G17 G40 G49 G80 G90;&#34;;
  GCode.value=GCode.value + &#34;G0 Z 50;&#34;;
  GCode.value=GCode.value + &#34;S2000&#34; +&#34; M03;&#34;;
  Y.value=-W1.value*0.5+((LREAL)T.value[0]).value*0.5;
  X.value=-(L1.value*0.5+((LREAL)T.value[0]).value*0.5+5);
  Z.value=-CHeight.value;
  GCode.value=GCode.value +&#34;G0 X&#34; + X.value + &#34; Y&#34; + Y.value +&#34;;&#34;;
  GCode.value=GCode.value + &#34;G01 Z&#34; + Z.value +&#34; F100;&#34;;
  for (j.value=0; j.value&#60;Passxy.value; j.value++)
  {
    GCode.value=GCode.value +&#34;G1 X&#34; + (-X.value) + &#34; Y&#34; + Y.value +&#34;;&#34;;
    Y.value= Y.value + ((LREAL)T.value[0]).value;
    GCode.value=GCode.value +&#34;G1 X&#34; + X.value + &#34; Y&#34; +Y.value +&#34;;&#34;;
  }
  GCode.value=GCode.value + &#34;G0 Z 50 &#34;;
  " />
</Algorithm>
  
```

Figure 6-5 “Conventional Cutting” algorithm design

6.3.1.3 The Simulation and Results

When running the Function Block, a GUI window is displayed as shown in Figure 6-6. Once the data has been input in the right format this trigger an event and the G-code is generated and shown in the right column (see Figure 6-6). The G-code can be validated through simulation by MasterCAM or NCspeed.

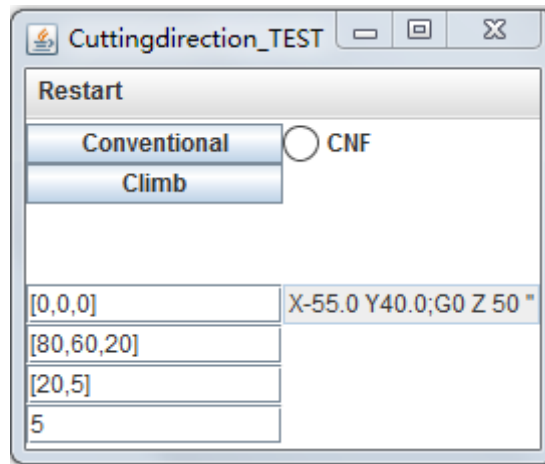

Figure 6-6 Run time of Function Block

In this example, the only difference to the final tool paths is the start point as well as the cutting direction which will be determined by the individual feature properties.

6.3.2 Application to a Simple Part

A simple machining feature is chosen for demonstrating the use and functionality of the knowledge model. Face milling was considered as the most suitable. The material for this part is aluminium. The 3D model and 2D drawing of this part are shown in Figure 6-7 and Figure 6-8 respectively. Both of them show the raw materials. In this case study, the adopted software is FBDK.

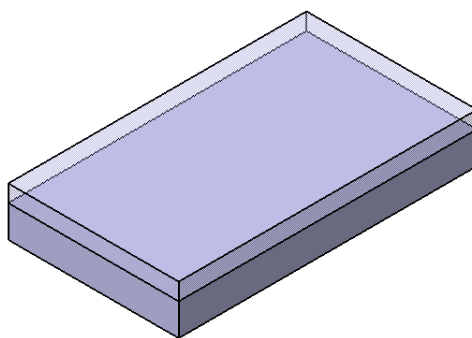

Figure 6-7 3D model of first case study

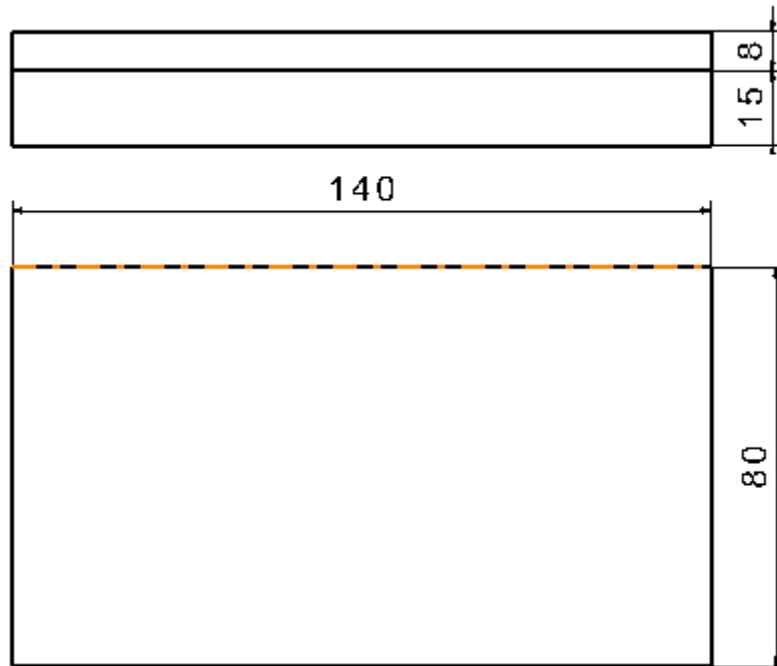

Figure 6-8 2D drawing of face milling part

6.3.2.1 Path Pattern Adopted

The different path patterns for face milling were presented in chapter 5.4.4.3. As illustrated in the rules and recommendations for face milling, one way and parallel spiral are suitable for roughing while zigzag and zigzag with loop are suitable for finishing (see Figure 6-9). In this example, the model was built for finishing with a zigzag pattern, which will be discussed in the next section.

Parameters for the use in function blocks	
	Origin(X,Y,Z)
	Dimensions (length, width, height)
	T (tool diameter, tool flute)
	CHeight (cutting height)
	Feed, Speed, Retract
Pattern and comments	If for roughing, then choose one way or parallel spiral
	If for finishing, then choose zigzag or zigzag with loop(high speed milling)
	Comments:
	One way: reduce milling force, less efficiency
	Parallel spiral: protect tool, bad surface roughness
	Zigzag: high efficiency
	Zigzag with loop: high efficiency, prevent the tool pauses and tremor

Figure 6-9 Rule for face milling

6.3.2.2 Algorithm

Algorithms are the core of the knowledge model. To improve performance of CNC tool path, two essential issues were considered in this algorithm.

First, the direction of the zigzag pattern determines the efficiency. Clearly, the direction of the tool path should follow the longest edge of the part to minimise the time of air cut at the end of each cut. As a result, the length and width of the part to be machine should be considered first. This leads to the algorithm shown in Figure 6-10.

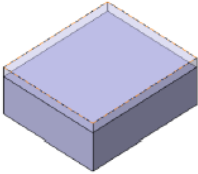
```

Text="if (((LREAL)Dimensions.value[0]).value<#60;((LREAL)Dimensions.value[1]).value)
{
L1.value=((LREAL)Dimensions.value[1]).value;
W1.value=((LREAL)Dimensions.value[0]).value;
X_Y.value=1;
}
else
{
W1.value=((LREAL)Dimensions.value[1]).value;
L1.value=((LREAL)Dimensions.value[0]).value;
X_Y.value=0;
}

```

Figure 6-10 Algorithm of length and width

Second, the stepover and stepdown of the path decides the orbit of the tool. The stepover is the length of two passes of cutting plane while the stepdown is the vertical depth of cutting.

From the semi-structured interviews, the stepover is the same as the diameter of the tool or less traditionally, the stepdown should also be less than the dimension of the flute of the tool. The algorithm resulting from the interviews is shown in Figure 6-11. In this algorithm, the stepover is the same as the diameter of the tool and the stepdown is the same as the dimension of the flute of the tool.

```

Passxy.value=Math.ceil((W1.value/ ((LREAL)T.value[0]).value));
Passz.value=Math.floor(((LREAL)Dimensions.value[2]).value/ ((LREAL)T.value[1]).value));

```

Figure 6-11 Algorithm of stepover and stepdown – common

In this research, the value of stepover and stepdown was recommended. From commercial software (MasterCAM and CATIA) and experience engineers (COMAC and FORMTEC GmbH), the stepover is 75% of the tool diameter while the stepdown is 50% of the tool flute. The judge algorithm for the stepover and stepdown is shown in Figure 6-12.

```

Passxy.value=Math.ceil((W1.value/ ((LREAL)T.value[0]).value*4/3));
Passz.value=Math.floor(((LREAL)Dimensions.value[2]).value/ ((LREAL)T.value[1]).value*2));

```

Figure 6-12 Algorithm of stepover and stepdown - FBs

6.3.2.3 The Final Model

Based on the model introduced in section 6.3.2 and identified considerations in section 5.4, the first design of face milling for FBs is illustrated in Figure 6-13. This model is event-driven and some factors have been simplified for illustration purposes.

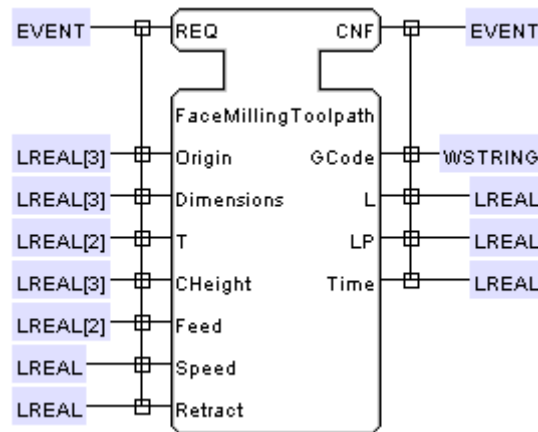

Figure 6-13 Implemented Function Block model for face milling

In this model, one event and seven types of data were defined. The “origin” represents the top 3D centre point on the surface of the raw material, which can be determined from the part. It should be noted that actual feature recognition is out of the scope of this research. The “Dimensions” is the length, width and height of the raw material. “T” shows the diameter and flute of the tool while the “CHeight” represents the height which needs to be cut. The “Retract” is the safe height for the part. As illustrated, there are three kinds of output data. The “Gcode” is the final tool path for the milling while “L” and “LP” represents the number of passes in horizontal and vertical directions.

6.3.2.4 The Simulation and Results

NCspeed is a software system for the simulation of 3- and 5-axis milling processes. The milling process is optimized with regard to machining time and process safety. Furthermore the checking of tool paths is possible (FORMTEC GmbH, 2012). In this case study, the length of part is 140mm, the width is 80mm and the tool diameter is 20mm. Figure 6-14 shows the simulation of tool path generated by Function Blocks while Figure 6-15 shows the manual

simulation from the interviewee. The stepover in Figure 6-14 is 15mm and 20mm in Figure 6-15. The comparison of these two methods was presented in Table 6-2. Although the first method is more time-consuming than the second, the first method ensures no burr nor design and manufacturing change, which is not available for second method.

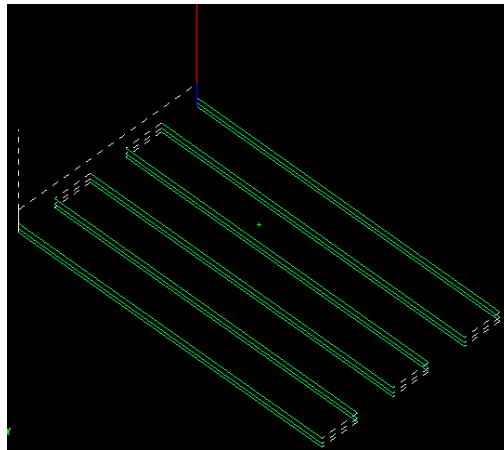

Figure 6-14 NCspeed simulation and visualisation of the optimised tool path generated by the Function Blocks approach

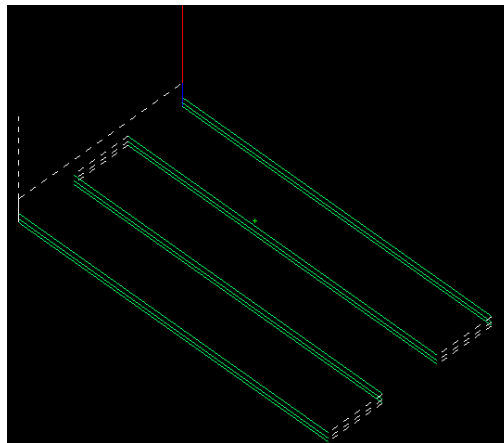

Figure 6-15 NCspeed simulation and visualisation of a typical manual tool path as collected from the interviewees

Table 6-2 comparison of two methods for CNC tool path generation

Properties	FBs	Manual
Time	06:32	04:28
Burr	No	Yes
Response time when design change	Immediately	Fixed, not sure

6.4 Expert Judgement

Response from the two experts, from COMAC and Cranfield University respectively, is detailed in Table 6-1. They participated in two questionnaires and the results were collected and analysed and used to improve or redefine the developed rules and recommendations as well as identify usefulness and weaknesses.

6.4.1 First Validation

In the first validation, three questions were presented, aimed at checking the correctness and necessity for improvements. The questions and answers are represented in Table 6-3.

Table 6-3 Questions and answers of first validation

Question1. Are these rules and recommendations easy to understand?

Expert A: It is understandable. However, some rules and recommendations should expand to be more explicit.

Expert B: Yes, it is easy.

Question2. Is the rule correct or wrong?

Expert A: Most of the rules are correct while some of which have the necessary to improve. For example, the rule “When facing, the recommended tool diameter is 20-80mm” is absolute. If the part is very big, 6000mm* 800mm* 200mm, the biggest recommended tool diameter, 80mm, is smaller relatively.

Expert B: Several rules and recommendations need to improve or redefine. 1. The rule “When milling in corners, tool radius cannot exceed 2* fillet radius” should be changed to “When milling in corners, tool diameter cannot exceed 2* fillet radius”; 2. The rule about steel material always uses cutting fluid or not should check its correctness; 3. The rule about cutting space should change the format of value, which should be percentage not absolute value.

Question3. Which rules should be improved or check further?

Expert A: The rule about coolant may need check more detailed.

Expert B: Value about stepdown was not sure.

According to the answers in Table 6-2, it can be seen that these rules and recommendations can be easily understood and need only slight modifications and extensions to meet full industry requirements. However, the experts agree to the usefulness of the rules in general at this proof-of-concept stage.

6.4.2 Final Validation

In the final validation, another three questions were presented, the aim of which being to illustrate the benefits and further direction of the research. Table 6-4 illustrates the questions and answers of final validation

Table 6-4 Questions and answers of final validation

Question1. Based on your experience, what benefits will be received after implementing Function blocks and rules for tool path generation?

Expert A: Workers don't need to plan the process. It makes simplify and optimal of tool path generation.

Expert B: it is better for less experienced processer.

Question2. What are the weakness of these rules and recommendations?

Expert A: It is a little general rule for tool path. For some rules, it cannot decide which is better or best because it depends on the environment.

Expert B: These rules are general for machining features. In fact, the machining features are complicated.

Question3. Based on your experience, how can these theories will be improved?

Expert A: More results from literature should be analysed to improve and experiments will also increase the correctness of research. Besides, you only choose two rules implemented for use in Function Blocks, more rules and more Function Blocks should be implemented.

Expert B: Machining features should be an important part of further research, like irregular features. Besides, the cutter is the most important factors of tool path generation as illustrated in this research, it also should be the improved.

The questionnaire results illustrate that less experienced workers can take advantage of the implementation the Function Blocks and tool path. Based on

this implementation, they can generate tool paths which are the better than the conventional paths.

Concerning the weakness of the developed rules and recommendations, a consensus that they were general was reached by two experts. There is space for improvement of the rules.

Regarding the question about the method of improvement, two experts gave the suggestion and comments from different aspects. In further research, more results from literature should be used and analysed. Furthermore, more implementation for Function Blocks should be designed and improved.

6.5 Summary

This chapter introduced the validation process of the developed rules and recommendations. During this process, two key rules and recommendations were selected and demonstrated followed by a structured interview and questionnaire with two independent experts from Cranfield University and COMAC. Comments about correctness and usefulness of the rules were gathered and analysed, some of which were adopted to improve or redefine the rules.

7 DISCUSSION AND CONCLUSIONS

7.1 Introduction

Rules and recommendations for CNC tool path generation have been developed as well as prototype models built to implement rules and recommendations for Function Blocks. Further, key rules have been validated for correctness and usefulness. This chapter will discuss the research and the research limitations which are based on the literature review and data collection from the manufacturing industries.

7.2 Research Findings and Discussion

Four main research findings, i.e. literature review, methodology, software tool design and case study will be discussed.

7.2.1 Literature Review

Although there is much research about CNC tool path from different aspects, there exists only little research on implemented FBs and tool paths generation. Function Blocks, as a core of IEC 61499, are designed to distributed control and automation. It is essential to build a knowledge model for FBs with the implementation of rules and recommendations for CNC tool path to meet the requirements for building dynamic distributed control systems.

The literature review assisted the author to get a fundamental knowledge related to the research subject, including knowledge modeling, IEC 61499 and Function Blocks as well as CNC tool path. Firstly, a basic understanding of knowledge modeling was achieved, including knowledge management, source of knowledge as well as methods and tools for knowledge capture and representation. This contributed to developing research methodology of knowledge modelling. The author then gained fundamental knowledge about FBs as well as CNC tool path, including the principles, programming language, methods, advantages and disadvantages. Based on the literature review, a questionnaire and semi-structured interview were conducted to gain information about CNC tool path. Furthermore, the research gap was also identified from

the literature review and driven the author to focus on the establishment of rules and recommendations. In data collection and analysis phase, literature review enable author to identify tacit information. Based on this, rules and recommendations were developed successfully.

However, this research has not covered some important literature. For example, how the function block recognizes the event and how the function blocks embed and control the machine is not reviewed which is essential for the implementation after knowledge modeling. The applications for function blocks in industries were also not reviewed. The developed knowledge which can be applied to industries may need further research.

7.2.2 Research Methodology

It is crucial to adopt an appropriate methodology for research. Due to the aim of this research, a qualitative methodology with the following methods: questionnaire, interviews and IDEF0, was developed. Although these methods were used in four stages, there is a close relationship between them.

The literature review and unstructured interviews undertaken in the first phase helped the author to build a fundamental knowledge of this research topic and scope. It also contributed to the design of the questionnaire, which is used in the second phase.

Questionnaire, semi-structured interviews and a literature review together supported the data collection and information of CNC tool path generation. Although CNC technology has developed over several decades, DPP is the first system implementing Function Blocks and tool path. Although some interviewees have more than ten years' experience, most have only three to five years' experience. Nevertheless, it is no doubt that these people, who come from different departments with different work experiences, have useful tacit knowledge and made the questionnaire more relevant to the research aim.

IDEF0 succeeded in terms of knowledge based on the first and second phase. The procedure of tool path generation in different industries may vary a little, which illustrates the necessity of identifying the procedure. The

recommendations of tool path generation procedure are capable of giving guidance to process planners so that they can choose the most appropriate one. Thus, rules and recommendations are also efficient based on IDEF0. In general, IDEF0 is used to develop diagram of CNC tool path generation to simplify the knowledge and make it suitable for sharing and training.

These methods and tools for knowledge modelling are suitable and adopted for this research, which are also the same for other similar research.

7.2.3 Software Tool Design

As the adopted emulator is FBDK (Function Block Development Kit), some proposed rules and recommendations were implemented in models. In this research, two models were developed using FBDK as emulator. In fact, much research uses FBDK as the basic and initial emulator, and it is the most appropriate for this research. The developed model through FBDK can also be used in other emulators, such as 4DIAC. The designs of models were developed by the rules and recommendations, listed in Appendix E. The models can provide guidance for further researchers to develop more models of tool path generations for more complex features. However, the environment of applying FBDK in real production was not tested, thus, the environment may need to be established and validated in further research.

7.2.4 Case Study and Validation

The integrated software tool was applied in the case study to show the implementation with rules and recommendation for two different purposes. Only two rules and recommendations were chosen for case study. The first case is a sample about conventional and climb milling which is chosen to demonstrate the use and functions of the basic Function Block. The result indicated the simplicity and the ease of use this software. Another case is an actual part which was chosen to demonstrate the value determination of stepover and stepdown for CNC tool path. Function Blocks technique makes better performance. Moreover, it can significantly reduce the time of tool path re-generation. Therefore, using Function Blocks for tool path generation is more

environmental friendly and can meet the requirement of industrial sustainable development.

Two validations from experts were conducted to identify the correctness of developed rules and recommendations as well as the benefits of implementation for Function Blocks through case study. Although experts confirmed the positive answers, some suggestions such as the development of more in-depth rules and recommendations were proposed.

7.3 Research Contribution

The main contributions of this research include the development of knowledge modelling procedure, rules and recommendations for tool path generation as well as applications for Function Blocks.

The rules and recommendation for tool path generation include the general requirements and influence factors of tool path. Furthermore, optimised path patterns for five common features were developed. These rules and recommendations make the milling operation more understandable through structured interviews with experts, especially for less experienced process planners.

Furthermore, the implementation of rules and recommendations for Function Blocks supports Distributed Process Planning. The models, developed by FBDK, can be triggered by events and response. Thus, implementing these models in Distributed Process Planning enable it response immediately in dynamic manufacturing environment, which can be build helping to optimise modern CAPP. Function Blocks, especially after the implemented rules and recommendations, add sense to the DPP.

7.4 Research Limitations

This first limitation is of research scope. Although some systems for Function Blocks have existed, for example, a reconfigurable robotic system which is used at PROFACTOR (4DIAC, 2013), Distributed Process Planning for Function Blocks is still a very challenging research topic, which is the dynamic

manufacturing environment. In this research, the abilities of Function Blocks, of controlling actual machines or doing on-board features recognition are not covered in this research.

The second limitation relates to the rules and recommendations. For machining operation, some in-depth studies about factors and features have enabled progress in tool path generation. The developed rules and recommendations for general, factors and features only identified some basic rules for tool path generation. Rules and recommendations for more complex features or even a comprehensive list of features and rules would need much more time and research. The goal of this research was to provide the necessary fundamental methodological template approaches and proof-of-concept results that can be used in further studies.

7.5 Future Research

Based on the collected comments from academics and experts as well as the discussion, the following three aspects for further development of these rules and recommendations can be presented:

- 1) Study in-depth the effect of tool path generation, such as tool offset and compensation, characteristic of different material.
- 2) Identify complex features to find suitable path patterns as well as implementation for Function Blocks.
- 3) Develop a handbook or manual for process planners.

In order to implement rules and recommendations, further research should be undertaken, namely a collection of comments from academics and experts about rules and recommendations to complete Knowledge Life Cycle.

7.6 Summary

The findings from the literature review, research methodology, software tool design as well as case study and validated have been discussed in this chapter.

Based on the discussion, contribution has been given. Furthermore, research limitations and possible further research were also discussed.

REFERENCES

- 4DIAC (2013), *Reconfigurable Robotic System*, available at: <http://www.fordiac.org/25.0.html> (accessed October, 2013).
- Abdullah, M. S., Benest, I., Evans, A. and Kimble, C. (2002), "Knowledge modelling techniques for developing knowledge management systems", *3rd European Conference on Knowledge Management*, September (2002), Dublin, Ireland, pp. 15-25.
- Abu-Nahleh, I., Mohammad, A. H., Hamdeh, M. A. and Sabri, A. T. (2010), "Developing a Theoretical Framework for Knowledge Acquisition", *European Journal of Science Research*, vol. 42, no. 3, pp. 453-463.
- Addison, O., Cao, X., Sunnar, P. and Fleming, G. J. (2012), "Machining variability impacts on the strength of a 'chair-side' CAD–CAM ceramic", *Dental Materials*, vol. 28, no. 8, pp. 880-887.
- Ammar-Khodja, S. and Bernard, A. (2008), "An overview on knowledge management", in *Methods and Tools for Effective Knowledge Life-Cycle-Management*, Springer, Berlin, pp. 3-21.
- Arezoo, B., Ridgway, K. and Al-Ahmari, A. (2000), "Selection of cutting tools and conditions of machining operations using an expert system", *Computers in Industry*, vol. 42, no. 1, pp. 43-58.
- Benardos, P. and Vosniakos, G. (2003), "Predicting surface roughness in machining: a review", *International Journal of Machine Tools and Manufacture*, vol. 43, no. 8, pp. 833-844.
- Boothroyd, G. and Knight, W. A. (2006), *Fundamentals of machining and machine tools*, CRC Press.
- Boughzala, I. and Ermine, J. (2006), *Trends in enterprise knowledge management*, Iste-Usa, Newport Beach, CA.
- Brezocnik, M., Kovacic, M. and Ficko, M. (2004), "Prediction of surface roughness with genetic programming", *Journal of Materials Processing Technology*, vol. 157, pp. 28-36.
- Cai, Y., Xi, G. and Wang, S. (2003), "Efficient tool path planning for five-axis surface machining with a drum-taper cutter", *International Journal of Production Research*, vol. 41, no. 15, pp. 3631-3644.
- CAPP-4-SMEs (2012a), *Formtec GmbH*, available at: <http://www.formtec.de> (accessed June, 2013).

- CAPP-4-SMEs (2012b), *PowerKut Limited*, available at:
<http://www.powerkut.co.uk> (accessed June, 2013).
- Changchun University of Science and Technology (2012), *Plane and complex surface machining*, available at:
http://jpk.cust.edu.cn/ligong/dzjc_b.asp?pageclass=1190302&id=509
 (accessed October, 2013).
- Chastain, S. (2004), *Metal casting: a sand casting manual for the small foundry*, Stephen Chastain.
- Chen, W., Xie, S., Zeng, F. and Li, B. (2011), "A new process knowledge representation approach using parameter flow chart", *Computers in Industry*, vol. 62, no. 1, pp. 9-22.
- Choy, H. and Chan, K. (2003), "A corner-looping based tool path for pocket milling", *Computer-Aided Design*, vol. 35, no. 2, pp. 155-166.
- Cuenca Tamarit, A., Al-Ashaab, A. and Shehab, E. M. H. (2010), *Knowledge modelling of the joining/welding processes*, Cranfield University, Cranfield, UK.
- D'Souza, R. M. (2006), "On setup level tool sequence selection for 2.5-D pocket machining", *Robotics and Computer-Integrated Manufacturing*, vol. 22, no. 3, pp. 256-266.
- Deng, H. (2000), "Flexible Manufacturing Technology in 21 Century", *China Engineering Science*, vol. 2, no. 9, pp. 12-23.
- El-Midany, T. T., Elkeran, A. and Tawfik, H. (1993), "Toolpath pattern comparison: Contour-parallel with direction-parallel", *Geometric Modeling and Imaging--New Trends, 2006*, IEEE, pp. 77.
- European Commission (2012), *Collaborative and Adaptive Process Planning for Sustainable Manufacturing Environments*, available at:
http://cordis.europa.eu/projects/rcn/105486_en.html (accessed October, 2013).
- FORMTEC GmbH (2012), *NCspeed*, available at:
http://www.formtec.de/fs_ncspeed_en.htm (accessed September, 2013).
- Ge, J. H., Yang, G. Q., Wang, Y. P., Zheng, J. Q. and Wang, H. L. (2013), "Simulation on Cutting Temperature during Milling Aluminum Alloy 7075-T7451", *Applied Mechanics and Materials*, vol. 274, pp. 444-447.
- Groover, M. P. (2007), *Fundamentals of modern manufacturing: materials processes, and systems*, Wiley.

- Henderson, M. R. and Anderson, D. C. (1984), "Computer recognition and extraction of form features: a CAD/CAM link", *Computers in Industry*, vol. 5, no. 4, pp. 329-339.
- Hou, M. and Faddis, T. (2006), "Automatic tool path generation of a feature-based CAD/CAPP/CAM integrated system", *International Journal of Computer Integrated Manufacturing*, vol. 19, no. 4, pp. 350-358.
- Hsu, C., Huang, C. and Wu, C. (2007), "Milling of MAR-M247 nickel-based superalloy with high temperature and ultrasonic aiding", *The International Journal of Advanced Manufacturing Technology*, vol. 34, no. 9-10, pp. 857-866.
- Hussain, T. and Frey, G. (2004), "Developing IEC 61499 compliant distributed systems with network enabled controllers", *Robotics, Automation and Mechatronics, 2004 IEEE Conference on*, Vol. 1, IEEE, pp. 507.
- International Electrotechnical Commission (2005), "IEC 61499-1: Function Blocks-Part 1 Architecture", *International Standard, First Edition, Geneva*, vol. 1.
- James, C., Thomas, S., Antonio, V., Valeriy, V. and Alois, Z. (2012), "The IEC 61499 Function Block Standard: Software Tools and Runtime Platforms", *ISA Automation Week 2012*, 9 January 2012, USA, ISA, pp. 125.
- Kao, Y. and Lin, G. C. (1996), "CAD/CAM Collaboration and remote Machining", *Computer Integrated Manufacturing Systems*, vol. 9, no. 3, pp. 149-160.
- Lartigue, C., Duc, E. and Affouard, A. (2003), "Tool path deformation in 5-axis flank milling using envelope surface", *Computer-Aided Design*, vol. 35, no. 4, pp. 375-382.
- Lewis, R. W. (2001), *Modelling Distributed Control Systems Using IEC 61499: Applying Function Blocks to Distributed Systems*, the Institution of Engineering and Technology, UK.
- Liao, W., Li, Y. G., Fang, T. and Cheng, S. (2008), "Research on feature-based rapid programming for aircraft NC parts", *Applied Mechanics and Materials*, vol. 10, pp. 682-687.
- Lightsey, B. (2001), *System Engineering Fundamentals*, Defense Acquisition University, Fort Belvoir, Virginia.
- Luthardt, R. G., Holzhüter, M. S., Rudolph, H., Herold, V. and Walter, M. H. (2004), "CAD/CAM-machining effects on Y-TZP zirconia", *Dental Materials*, vol. 20, no. 7, pp. 655-662.

- Madison, J. (1996), *CNC Machining Handbook: Basic Theory, Production Data, and Machining Procedures*, Industrial Press Inc.
- Milton, N. (2007), "Overview of the Step-by-step Procedure", in *Knowledge Acquisition in Practice*, Springer, London, pp. 9-22.
- Olsen, S., Wang, J., Ramirez-Serrano, A. and Brennan, R. W. (2005), "Contingencies-based reconfiguration of distributed factory automation", *Robotics and Computer-Integrated Manufacturing*, vol. 21, no. 4, pp. 379-390.
- Overby, A. (2010), *CNC machining handbook: building, programming, and implementation*, McGraw-Hill, Inc.
- Paul, R. (1979), "Manipulator Cartesian path control", *Systems, Man and Cybernetics, IEEE Transactions on*, vol. 9, no. 11, pp. 702-711.
- Pessoles, X. and Tournier, C. (2009), "Automatic polishing process of plastic injection molds on a 5-axis milling center", *Journal of Materials Processing Technology*, vol. 209, no. 7, pp. 3665-3673.
- Rangarajan, A. and Dornfeld, D. (2004), "Efficient tool paths and part orientation for face milling", *CIRP Annals-Manufacturing Technology*, vol. 53, no. 1, pp. 73-76.
- Ranky, P. (1983), *The design and operation of FMS*, Elsevier Science Pub., New York.
- Rauch, M., Duc, E. and Hascoet, J. (2009), "Improving trochoidal tool paths generation and implementation using process constraints modelling", *International Journal of Machine Tools and Manufacture*, vol. 49, no. 5, pp. 375-383.
- SANDVIK Coromant (2013), *Milling*, available at: http://www.sandvik.coromant.com/en-gb/knowledge/milling/getting_started/general_guidelines/keep_cutter_engaged/Pages/default.aspx (accessed October, 2013).
- Senatore, J., Segonds, S., Rubio, W. and Dessen, G. (2012), "Correlation between machining direction, cutter geometry and step-over distance in 3-axis milling: Application to milling by zones", *Computer-Aided Design*, vol. 44, no. 12, pp. 1151-1160.
- Shan, C., Liu, W., Lin, X. and Zhang, D. (2013), "Three half-axis tool orientation optimization for spiral machining of blades", *The International Journal of Advanced Manufacturing Technology*, vol. 68, no. 9-12, pp. 2601-2609.

- Smid, P. (2003), *CNC programming handbook: a comprehensive guide to practical CNC programming*, Industrial Press Inc.
- Smith, S. and Dvorak, D. (1998), "Tool path strategies for high speed milling aluminum workpieces with thin webs", *Mechatronics*, vol. 8, no. 4, pp. 291-300.
- Sun, X. (2011), "*Knowledge modelling for the laser beam welding process in the aircraft industry*", MSc thesis, Cranfield University, Cranfield, uk.
- Swartout, B. and Gil, Y. (1996), *Flexible knowledge acquisition through explicit representation of knowledge roles*, Defense Technical Information Center.
- Thomas, M., Turner, S. and Jackson, M. (2010), "Microstructural damage during high-speed milling of titanium alloys", *Scripta Materialia*, vol. 62, no. 5, pp. 250-253.
- Vernadat, F. B. (2003), *Enterprise modelling and integration*, Springer.
- Vivancos, J., Luis, C., Costa, L. and Ortiz, J. (2004), "Optimal machining parameters selection in high speed milling of hardened steels for injection moulds", *Journal of Materials Processing Technology*, vol. 155, pp. 1505-1512.
- Wang, H. and Li, J. (1993), *Computer-aided process planning*, Elsevier Science.
- Wang, L., Jin, W. and Feng, H. (2006), "Embedding machining features in function blocks for distributed process planning", *International Journal of Computer Integrated Manufacturing*, vol. 19, no. 5, pp. 443-452.
- Wang, L., Zhao, W., Ma'ruf, A. and Hoshi, T. (1996), "Set-up less fabrication technology incorporated with machining feature-based CAD/CAM system for low volume and high product-mix machining center workshop", *Workshop Proceedings of IMEC*, pp. 95.
- Wang, L., Adamson, G., Holm, M. and Moore, P. (2012), "A review of function blocks for process planning and control of manufacturing equipment", *Journal of Manufacturing Systems*, vol. 31, no. 3, pp. 269-279.
- Wang, L., Brennan, R. W., Balasubramanian, S. and Norrie, D. H. (2001), "Realizing holonic control with function blocks", *Integrated Computer-Aided Engineering*, vol. 8, no. 1, pp. 81-93.
- Wang, L., Feng, H. and Cai, N. (2003), "Architecture design for distributed process planning", *Journal of Manufacturing Systems*, vol. 22, no. 2, pp. 99-115.

- Wang, L. and Shen, W. (2003), "DPP: An agent-based approach for distributed process planning", *Journal of Intelligent Manufacturing*, vol. 14, no. 5, pp. 429-439.
- Wang, L., Song, Y. and Gao, Q. (2009), "Designing function blocks for distributed process planning and adaptive control", *Engineering Applications of Artificial Intelligence*, vol. 22, no. 7, pp. 1127-1138.
- Wang, W., Li, Y. and Ma, Y. (2013), "Towards a Feature-based Agent-driven NC Tool Path Generation to Support Design and Process Changes", *Computer-Aided Design & Applications*, vol. 10, no. 4, pp. 603-618.
- Wang, X. and Dong, C. (2009), "Improving Generalization of Fuzzy IF--THEN Rules by Maximizing Fuzzy Entropy", *IEEE Transactions on Fuzzy Systems*, vol. 17, no. 3, pp. 556-567.
- Whiteside, A. (2008), "Developing a current capability design for a manufacture framework in the aerospace industry", MSc thesis, Cranfield University, Cranfield, UK.
- Winch, G. M. and Carr, B. (2001), "Processes, maps and protocols: understanding the shape of the construction process", *Construction Management and Economics*, vol. 19, no. 5, pp. 519-531.
- Xiong, Z., Zhuang, C. and Ding, H. (2011), "Curvilinear tool path generation for pocket machining", *Proceedings of the Institution of Mechanical Engineers, Part B: Journal of Engineering Manufacture*, vol. 225, no. 4, pp. 483-495.
- Xu, X., Wang, L. and Newman, S. T. (2011), "Computer-aided process planning—A critical review of recent developments and future trends", *International Journal of Computer Integrated Manufacturing*, vol. 24, no. 1, pp. 1-31.
- Yao, C. F., Tan, L., Wu, D. X., Ren, J. X. and Zhang, D. H. (2013), "Experimental Study on Surface Integrity in High-Speed End Milling of Titanium Alloy TB6", *Applied Mechanics and Materials*, vol. 328, pp. 867-871.
- Yli - Renko, H., Autio, E. and Sapienza, H. J. (2001), "Social capital, knowledge acquisition, and knowledge exploitation in young technology - based firms", *Strategic Management Journal*, vol. 22, no. 6 - 7, pp. 587-613.
- Yoong, L. H., Roop, P. S., Vyatkin, V. and Salcic, Z. (2009), "A synchronous approach for IEC 61499 function block implementation", *IEEE Transactions on Computers*, vol. 58, no. 12, pp. 1599-1614.
- Zhou, T. R., Zhang, D. L. and Guo, J. L. (2013), "CNC Milling Tool of Choice to Explore", *Advanced Materials Research*, vol. 706, pp. 1246-1249.

APPENDICES

Appendix A Interview questions and Results

This interview lasted for 30 minutes. The questions and answers were collected in the following part.

Question 1: What factors will be considered before manufacturing of mechanical product?

Answer: The academic expert explained process of manufacturing in detail. It can be divided into three stages, Preparation, manufacturing and post-processing. In the preparation stage, process planning was needed, sometimes, as well as process simulation. In the manufacturing stage, the worker will operate according to the documents in the preparation stage. At last but not least, some parts need post-treatments. There are many factors in the manufacturing procedure, for example, the capability of machine, the process of process planning. It maybe affects the tolerance of part if two steps were changed. In addition, the geometry and tolerance of part, the capability of tools will also affect the mechanical product.

Question 2: Based on your experience, what factors will be considered during the tool path generations?

Answer: the capability of tool, the capability of machine, tool path, material, speed rate, coolant, and sequences of machining features and so on should be taken into account in the procedure of tool path generation.

Question 3: What the difference of tool path generation between manual and automatic

Answer: Automatic is the developing trend. However, it also can meet the requirement if the tool path was generated manual for simple part. In general, tool path generation automatically makes the part more accurate. In the stage of maintenance, Manual programming makes advantages. The complicated tool path by CAM software cannot be modified easily

Question 4: I want to develop a knowledge model for tool path generation. Can you give any comments that can help develop this model?

Answer: If you want to build knowledge model, you should find methods to help manage knowledge life cycles, which means considering ways of knowledge identification, capturing, representation and sharing.

Question 5: This is my initial work about aim and objectives. Could you have a look and give me some suggestion?

Answer: (1) there are many methods that can be used to generate tool path, you should find new method.

(2) In the procedure of tool path generation, many factors should be considered. You can do some simplification. Research work is a process from simple to complex, as well as knowledge management.

(3) You should find some methodologies for knowledge modelling, like questionnaire, table or diagram for simplifying knowledge.

Appendix B Questionnaire——Capturing the Machining Features and Tool Path

This questionnaire is part of MSc research project entitled “Knowledge modelling for NC tool paths for Function blocks” aiming to collect information about the process of generating tool path. With the collected information, a knowledge model about the tool path process would be built aiming to guide engineers for designing metal structure and making metal strategy.

Thanks for participating this research. The analysis results can be sent to you if required. And the gathered data will be processed under the confidential protection. The original records will be destroyed when the thesis is completed and not be spread to any other organisation or person.

Background: IEC 61499 is an IEC open standard for distributed control and automation. In this standard, Function block was defined. To encapsulate data and reuse is the most important characteristics of Function block. In recent years, the researches of using function block in process planning are gradually increasing.

Most existing Computer aided Process Planning (CAPP) systems are designed based on sequential information flow, which is static. For example, process engineer generates tool path for manufacturing, once there is something wrong in the manufacturing process, like the tool is damaged, the entire process will be terminated until the operator re-inspection.

Distributed Process Planning (DPP) is to use Function Blocks to control the all resources, devices and applications. In this case, process engineer generates tool path according to the features, which is dynamic.

There must be some databases to support the DPP. The object of this research is the tool path of manufacturing. The goal is to build knowledge system based on manufacturing features. The process engineer can call this system if required.

Note: Please write the letter of your choice(s) (e.g. A, B, or C ...) in the box or write your answer on the line below the question. If other, please list it out.

Name (optioned): _____

Company/Institute (optioned): _____

B.1 General Information

G1. Please choose the type of your company/Institute? (Please choose the most suitable option)

A. Aircraft manufacturing company

B. R&D Institute

C. University

D. Other

Other: _____

G2. What is your job? (Please choose the most suitable option.)

A. Design engineer

B. Manufacturing engineer

C. Research

D. Student

E. Other

Other: _____

G3. How long have you worked at this job?

A. Ten years or more

B. Five to ten years

C. Three to five years

D. one to three years

E. less than one year

G4. Which of the following domains have you ever known about, or have experience on?

A. Computer aided process planning (CAPP)

B. Structure design

C. tool path generation

B.2 Tool path and Manufacturing Features

T1. From your experience, which is the method you use for tool path?

A. manual

B. automatic

C. Other

Other:

T2. From your experience, which software you have used for designing (You can choose three options at most)

A. UG

B. Pro/E

C. CATIA

D. AUTOCAD

E. CAXA

F. SolidWorks

G. Autodesk Inventor

H. Other

I. Not use

Other:

T3. From your experience, which software you have used for manufacturing (CAM) (You can choose three options at most)

- | | |
|--------------|---------------|
| A. UG | B. Pro/E |
| C. CATIA | D. AUTOCAD |
| E. CAXA | F. SolidWorks |
| G. MasterCAM | H. WorkNC |
| I. Other | J. Not use |

Other: _____

T4. From your experience, what are the greatest advantages of NC tool path generation automatically (You can choose four options at most).

- | | |
|-------------------------|--------------------------------|
| A. High efficiency | B. Errors resistance |
| C. cost saving | D. Reduce material consumption |
| E. production stability | F. process simulation |
| G. Other | H. Not Sure |

Other: _____

T5. From your experience, which machine you have used? (You can choose three options at most)

- | | |
|-------------|-------------|
| A. Milling | B. Turning |
| C. Planning | D. Boring |
| E. Grinder | F. Drilling |

G. Other

Other:

T6. From your experience, which material would be used usually? (You can choose as many options as you wish)

A. Aluminium

B. Steel

C. Titanium

D. Other

Other:

T7. From your experience, what are the most important factors in machining a mechanical product? (You can choose four options at most)

A. machine

B. tool

C. speed rate

D. material

E. Coolant

F. tool path

G. Other

H. Not Sure

Other:

T8. From your experience, which are the essential stages of manufacturing? (You can choose as many options as you wish)

A. Workpiece preparation

B. Pre-treatment

C. Locate the workpiece

D. Clamping the workpiece

E. Adjust parameter

F. Manufacturing

- G. Release the workpiece
- I. Inspection
- K. Other

- H. Post-treatment
- J. Process simulation
- L. Not Sure

Other:

T9. From your experience, which are the essential stages of tool path generation? (You can choose as many options as you wish)

- A. Model and geometry
- C. Tool
- E. Adjust parameter
- G. Path simulation

- B. Machine
- D. Path of tool
- F. Generation tool path
- H. Other

Other:

T10. What should be taken into account when designing the machine parts? (You can choose as many options as you wish)

- A. Design requirement
- C. Capability of machine
- E. Manufacturing method
- G. Tolerance
- I. Not sure

- B. Capability of material
- D. Shape of workpiece
- F. Geometry information
- H. Other

Other:

T11. From your experience, which are the usual manufacturing features? If possible, give other usual manufacturing features. (You can choose as many options as you wish)

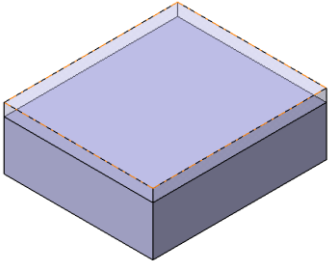
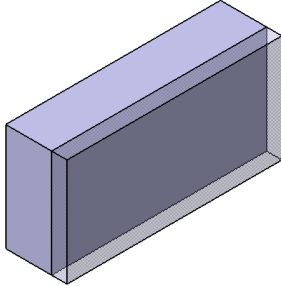
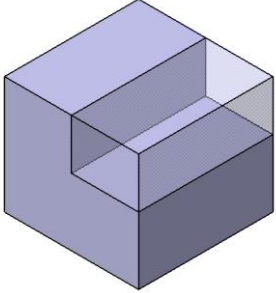
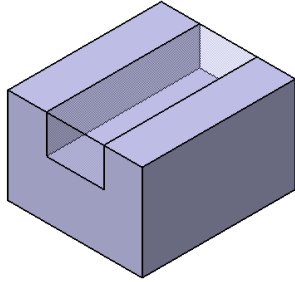
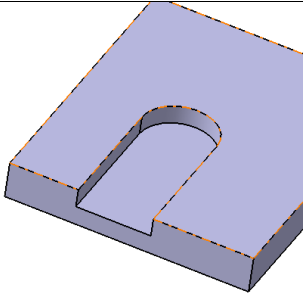
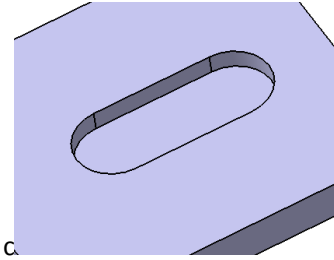
 <p style="text-align: center;">Face</p>	 <p style="text-align: center;">Side</p>
A	B
 <p style="text-align: center;">Step</p>	 <p style="text-align: center;">Thru Slot</p>
C	D
 <p style="text-align: center;">Semi-Blind Slot</p>	 <p style="text-align: center;">Blind Slot</p>
E	F

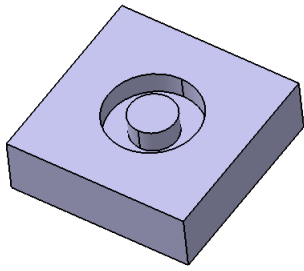
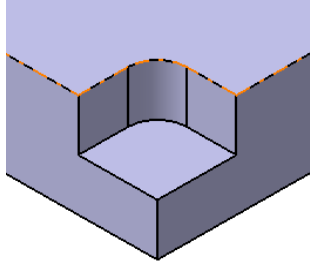
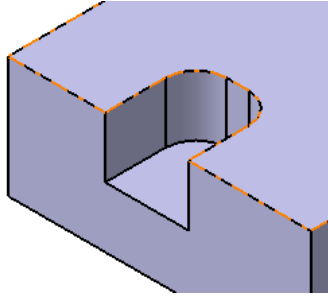
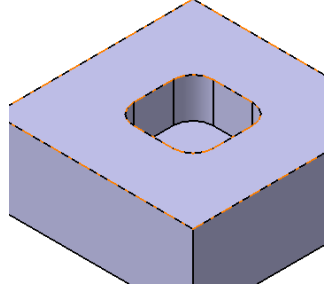
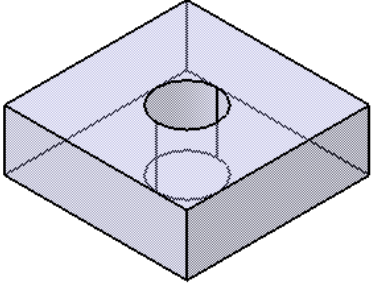
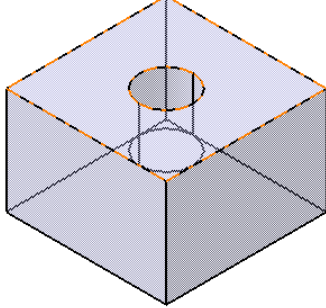
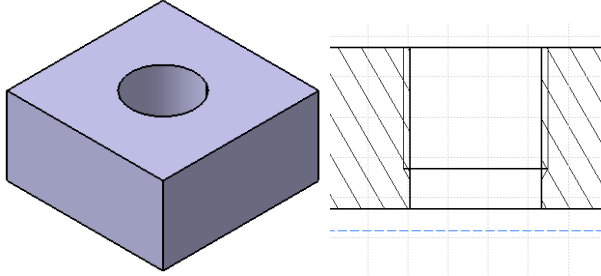
 <p data-bbox="459 544 529 577">Ring</p> <p data-bbox="480 607 509 640">G</p>	 <p data-bbox="962 533 1161 566">2-side Pocket</p> <p data-bbox="1046 607 1075 640">H</p>
 <p data-bbox="395 969 595 1003">3-side Pocket</p> <p data-bbox="488 1037 502 1070">I</p>	 <p data-bbox="962 969 1161 1003">4-side Pocket</p> <p data-bbox="1050 1037 1074 1070">J</p>
 <p data-bbox="419 1473 571 1507">Thru Hole</p> <p data-bbox="475 1529 515 1563">K.</p>	 <p data-bbox="986 1473 1137 1507">Blind Hole</p> <p data-bbox="1042 1529 1082 1563">L.</p>
 <p data-bbox="667 1899 898 1933">M. Tapped Hole</p>	

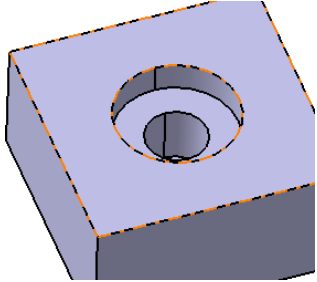
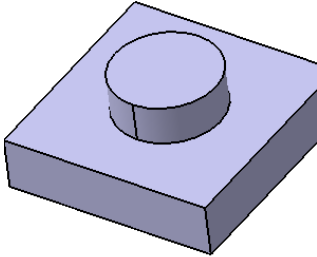
 <p data-bbox="421 539 572 573">Sunk Hole</p>	 <p data-bbox="1027 555 1099 589">Boss</p>
<p data-bbox="483 613 507 647">N</p>	<p data-bbox="1050 613 1074 647">O</p>

Other:

T12. What is your attitude about developing machining? Given reason for your choice, if possible.

A. Very support

B. Support

C. Partial support

D. Non-support

E. Reject

F. Other

Other:

Reason:

B.3 Capturing tool path process capabilities

C1. From your experience, what are the most important benefits of capturing the tool path process capability (You can choose four options at most)? If you choose 'Other', please type it out and give your reason.

A. promote knowledge management of tool path generation

- B. ensure and promote tool path capability
- C. contribute to structure design
- D. reduce the manufacturing cost
- E. accelerate and spread the application of machining
- F. benefit making machining strategy
- G. Other
- H. Not Sure

Other:

C2. Which do you think are the difficulties of capturing the tool path process capabilities? (You can choose four options at most)

- A. No definite definition
- B. No existing method or procedure
- C. Too many factors
- D. Not enough statistics from application
- E. No systemic research
- F. Difficult to grasp comprehensive data as secrecy reason
- G. Other
- H. Not Sure

Other:

C3. Do you think it is necessary to capture the tool path process capabilities? ('Yes' or 'No') Please give your reasons from your experience, if possible.

Reason:

C4. Please write down any words you would like to give this project.
(Suggestion or comment)

Suggestion:

End of questionnaire

Thanks for your time

Email: 5vvv-xiao@163.com

Appendix C Results of questionnaire

C.1 General Information

G1. Please choose the type of your company/Institute? (Please choose the most suitable option)

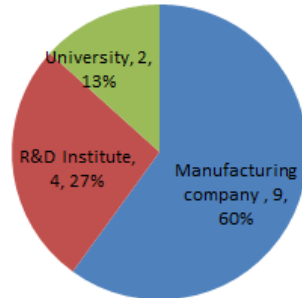

G2. What is your job? (Please choose the most suitable option.)

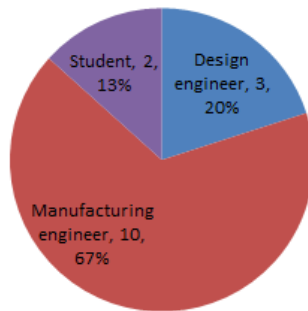

G3. How long have you worked at this job?

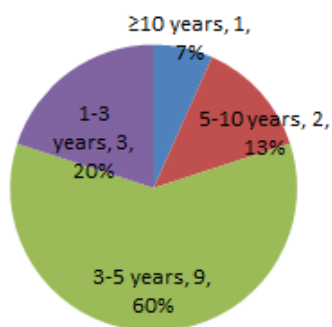

G4. Which of the following domains have you ever known about, or have experience on?

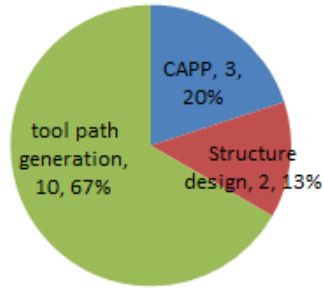

C.2 Tool path and Manufacturing Features

T1. From your experience, which is the method you use for tool path?

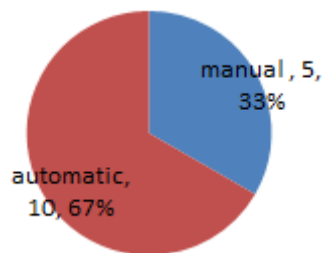

T2. From your experience, which software you have used for designing (You can choose three options at most)

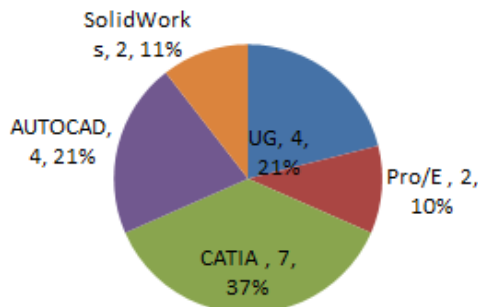

T3. From your experience, which software you have used for manufacturing (CAM) (You can choose three options at most)

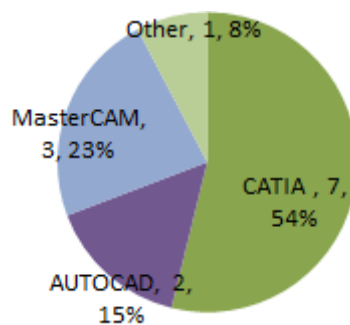

T4. From your experience, what are the greatest advantages of NC tool path generation automatically (You can choose four options at most).

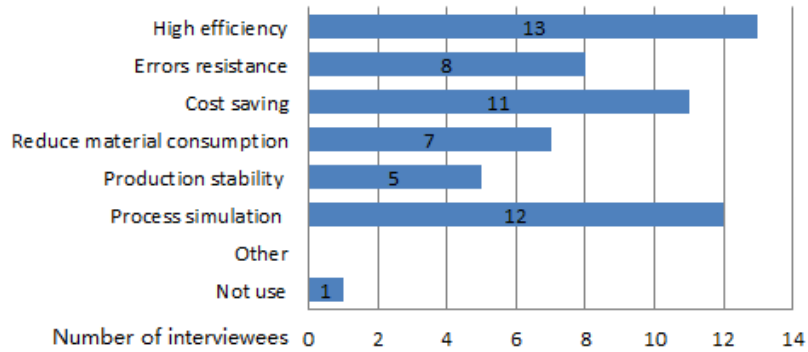

T5. From your experience, which machine you have used? (You can choose three options at most)

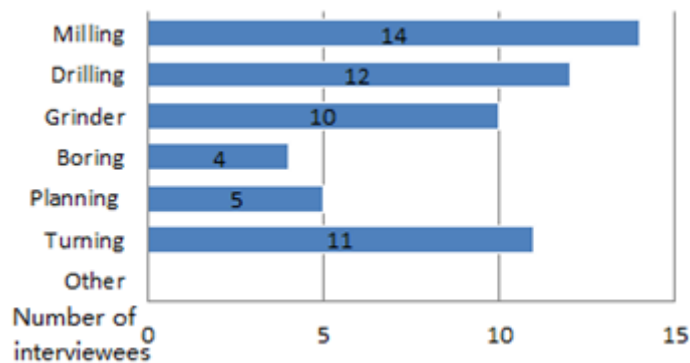

T6. From your experience, which material would be used usually? (You can choose as many options as you wish)

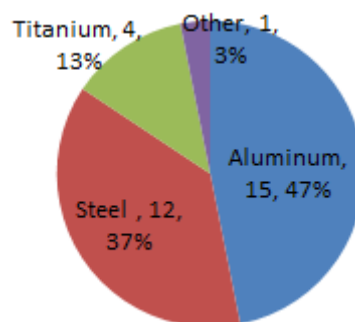

T7. From your experience, what are the most important factors of the mechanical product? (You can choose four options at most)

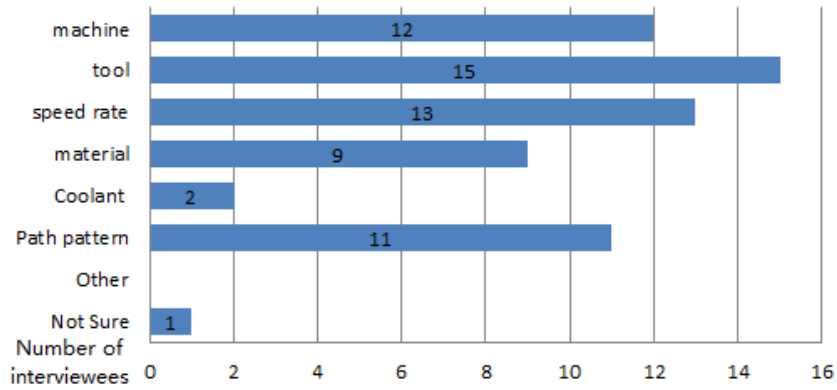

Comments: speed rate contains feed rate and spindle speed

T8. From your experience, which are the essential stages of manufacturing? (You can choose as many options as you wish)

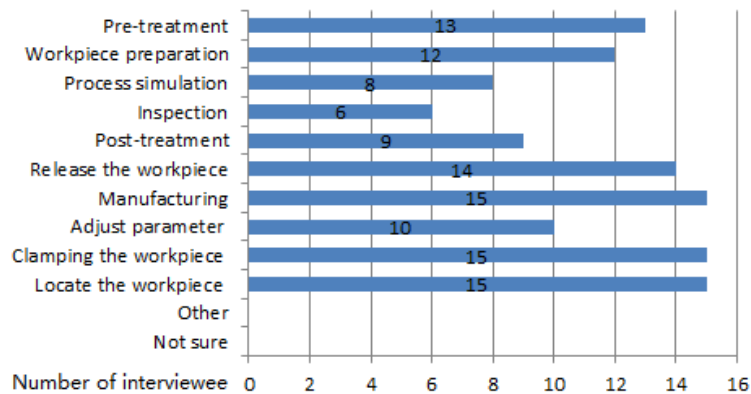

Comments: Machining contains three sections, roughing, semi-finishing and finishing. In general, roughing and finishing are enough to operate. All of these three sections have the tool path, which can generate by requirements

T9. From your experience, which are the essential stages of tool path generation? (You can choose as many options as you wish)

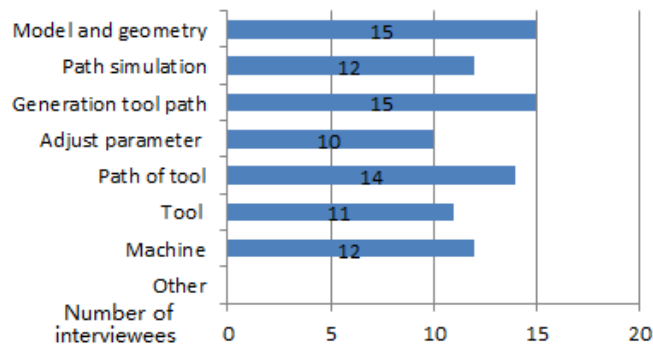

Comments: Model and geometry is the fundamental of the whole process. It decided whether the workpiece should be operated by milling machine. Once the process planners make sure this issue, the machine, tool and path can be chosen as well as the parameter modification. Then, the tool path can be generated. The generated tool path can be simulated if necessary. Sometimes, post processor will be needed because some tool path, which generated by commercial software, cannot be used directly to NC machine.

T10. What should be taken into account when designing the machine parts? (You can choose as many options as you wish)

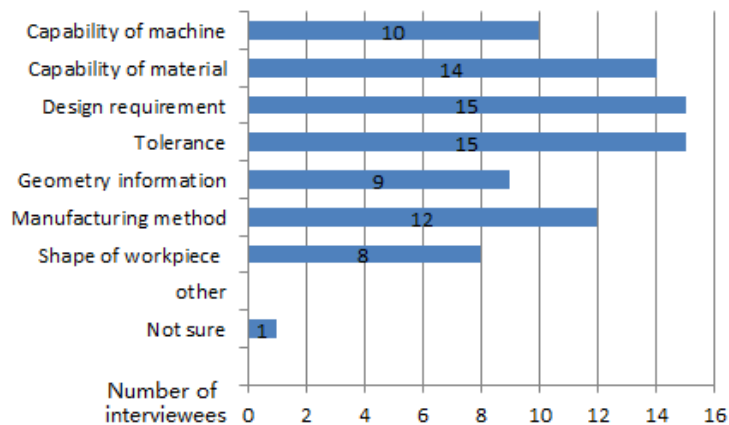

T11. From your experience, which are the usual manufacturing features? If possible, give other usual manufacturing features. (You can choose as many options as you wish)

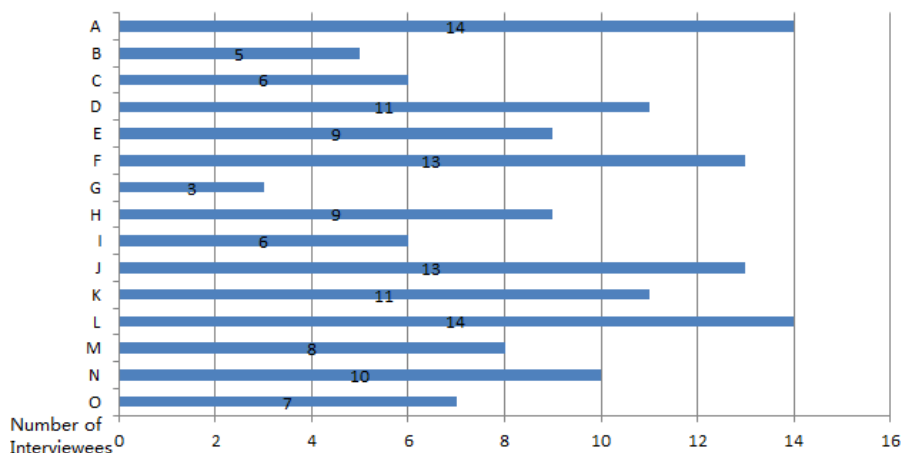

T12. What is your attitude about developing machining? Give reasons for your choice, if possible.

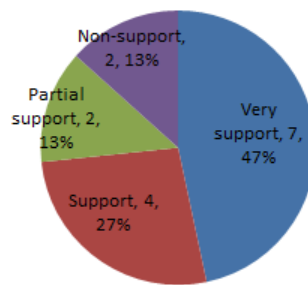

Reasons: ① For the simple parts, there is no necessary to generate by CAM system as well as generated by Function Block.

② The tool path generated by CAM system is better may be better. It can generate different patterns as wish.

C.3 Capturing tool path process capabilities

C1. From your experience, what are the most important benefits of capturing the tool path process capability (You can choose four options at most)? If you choose 'Other', please type it out and give your reason.

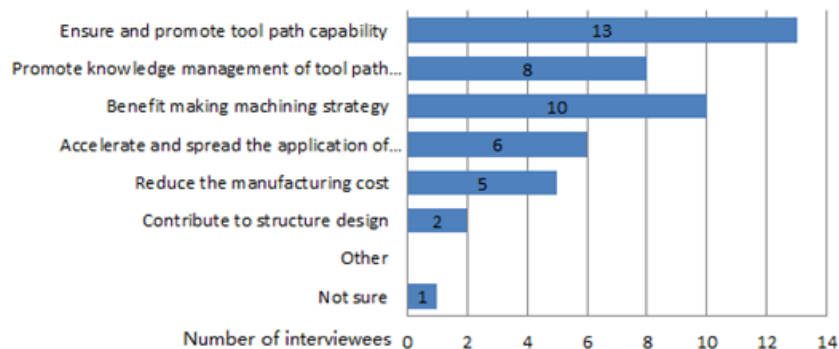

C2. Which do you think are the difficulties of capturing the tool path process capabilities? (You can choose four options at most)

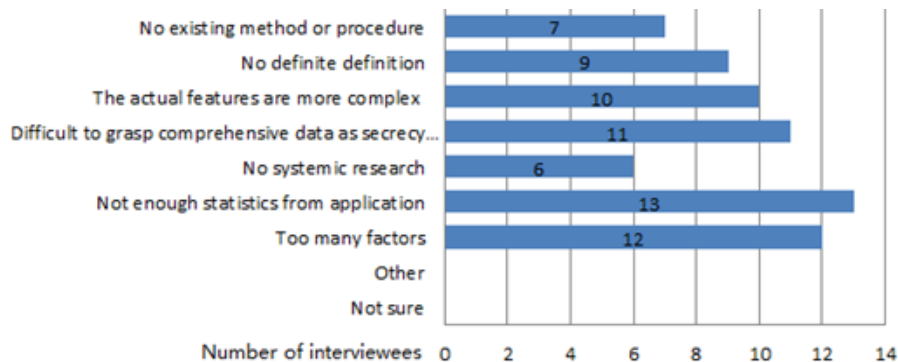

C3. Do you think it is necessary to capture the tool path process capabilities? ('Yes' or 'No') Please give your reasons from your experience, if possible.

Almost everyone thought it is necessary to capture the tool path process capabilities except two people. All the interviewees believe in shop floor, the environment depends. Some thought it would help to further understand the tool path process and its influencing factors and improve the performance of machining. Some thought capture the tool path process capabilities and used in Function block would supply a new technology for manufacturing capabilities. One of the interviewee with 3 years thinks it is enough to generate the path by CAM system or manual.

C4. Please write down any words you would like to give this project. (Suggestion or comment)

Most interviewees thought this research should consider the application of the achievements or developed results. The case study should test or do experiments for the application to validate the rules and recommendations.

Appendix D Questions and answers of semi-structured interviews

Q1. What is the usual procedure of milling? Is every product experienced this procedure?

Answer1. In general, the procedure of milling contains three sections, roughing, semi-finishing and finishing. Not every section is necessary. In most case, semi-finishing is not included.

Q2. What are the usual cutters of milling? Do they have difference?

Answer2. There are many cutters of milling, but not each cutter is used in company. They have different material, dimension and hardness, so they can use in different applications. The companies of tools have their own product manual.

Q3. Can you give some examples of milling cutters and there applications?

Answer3.

Cutter type	occasions
Ball nose cutters	Profile milling of 3D shapes
Round insert cutters	Face milling as well as profiling operations, and have excellent ramping capabilities.
90° shoulder milling cutters	versatile, the most common type of cutter

Q4. In the process of roughing or finishing, what is the usual maximum cutting depth?

Answer4. Maximum chip thickness is the most important parameter for achieving a productive and reliable milling process.

Effective cutting will only take place when this is maintained at a value correctly matched to the milling cutter in use.

For straight cutting insert, $h_{ex} = f_z \times \sin k_r$

k_r Entering angle

f_z Feed per tooth

h_{ex} Maximum cutting depth

Value of h_{ex} that is too high will overload the cutting edge, which can lead to breakage.

This is theoretical calculation methods.

From the experience, for example with aluminium, there is some difference in different occasions.

Occasion	Procedure	Depth
plane	roughing	1mm
	finishing	0.2-0.3mm
profile	roughing	0.5-0.7mm
	finishing	0.1-0.2mm

These data is the usual data, which should modify according to the actual in the machining.

Q5. How do you decide the stepover of tool path?

Answer5. In CAM system, the stepover can modify by process planner. For the people who generate tool path manually, the range of value is smaller compared to CAM system, for the face milling or pocket, for example, the part is 100mmx100mmx100mm, maybe the stepover is only 1-2mm. the value depend on the part. The part is large, the stepover is also large.

Q6. How do you decide the cutter diameter?

Answer6. It depends on different people, demanded efficiency by companies and surface roughness. For the pocket, there is limit of the value. In general, the diameter cannot exceed 2 X fillet radius; it should be smaller, especially in the stage of finishing. It should be smaller than 1X fillet radius

Q7. What is the usual speed of milling? Can you give some example?

Answer7. Cutting speed (m/min):

$$V_c = \frac{D_{cap} \times \Pi \times n}{1000}$$

D_{cap} (mm), cutting diameter at actual depth of cut

n (rpm), spindle speed

Cutting speed is closely related with materials, tools and other factors. In actually experience in general, the higher product requirements are, the slower of cutting speed is. For example, Aluminium, which is the most common used for milling, the spindle speed was set at 400-800rpm generally.

For high-speed milling, it will make difference in spindle speed.

Q8. Cutting margin will be left in the procedure of roughing, which will be cut in the finishing. What about the cutting margin?

Answer8. It cannot be conducted directly about the cutting margin. It depends on the material, speed and other factors. Every engineer can decide different cutting margin. For the aluminium, the cutting margin can be set from 0.5-0.6mm in general.

Q9. How do you decide the path of tool? Is there any special requirement?

Answer9. In fact, there is no special requirement of the path as long as the results meet the requirements. However, different tool path patterns may make different accuracy of product. There is a basic rule for tool path ,that is Keep cutter constantly engaged. For example, there is two method for facing, the second one should be chosen.

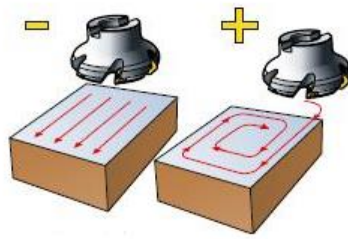

Figure Keep cutter constantly engaged.

From another aspect, to decide where the start point is an issue. Two different direct, conventional and climb. Climb milling is when the direction of cut and rotation of the cutter combine to try to "suck" the mill up over (hence it's called "climb" milling) or away from the work. Conventional is completely opposite

Q10. Can you give some examples of machining features and tool path?

Answer10. The common example is face milling. From experience and CAM system, one pass, one way, zigzag, parallel spiral can be used. They have different characteristics. One pass, the tool must be larger than the face. One way makes more time because it must return to the side of beginning. Zigzag is the typical choice. It saves time and parallel spiral protect tools.

Another example is slot, which is different regarding to the patterns. One way or zigzag is still suitable for thru slot, but not blind slot. It may need layered milling, cut obliquely between layers. If the slot is not regular, it will be different for process planner who generate NC tool path manually.

For the feature of hole, it may be simple. The diameter of tool should be chosen as same as the hole. Another method is to drill a smaller hole than the demanded and at last, using the tool whose diameter is as same as the demand.

Q11. How the material affect the tool path generation?

Answer11. Material is a factor of spindle speed. Sometimes, if the value of spindle speed is higher, the tool may destroy the material. For Aluminium milling, the cutting speed can be defined from 0 – 8000r/min.

Q12. Is there any comments of milling?

Answer12. For the side milling, like the Keystone (see the figure), it has two different methods to generate tool path. The traditional method is similar like face milling, in which the tool path can be generated manual or automatic. The manual method can be done only when is 30° , 45° or 60° , which can be calculated. However, these method is inefficient, which cutting depth must be smaller to prevent to be stepped shape.

The other method is grinding common tool to be special tool, which can be coincided with Keystone. Using milled tool can make sure the accuracy of the product.

Q13. When you determine NC tool path, how will you decide the coolant?

Answer13. Some material or machine may need coolant while some may not. When less experience worker cannot make sure, they will ask more experienced workers or search from the manual. In general, cutting fluid should always be used in aluminium while Cast iron preferred no coolant.