

CIRP 25th Design Conference Innovative Product Creation

Redesign Optimization for Manufacturing Using Additive Layer Techniques

Konstantinos Salonitis*, Saeed Al Zarban

Manufacturing and Materials Department, Cranfield University, Cranfield, MK 10 7DX, UK

* Corresponding author. Tel.: +44 (0)1234 758347; fax: 44 (0) 1234 751172. E-mail address: k.salonitis@cranfield.ac.uk

Abstract

Improvements in additive manufacturing technologies have the potential to greatly provide value to designers that could also contribute towards improving the sustainability levels of products as well as the production of lightweight products. With these improvements, it is possible to eliminate the design restrictions previously faced by manufacturers. This study examines the principles of additive manufacturing, design guidelines, capabilities of the manufacturing processes and structural optimisation using topology optimisation. Furthermore, a redesign methodology is proposed and illustrated through a redesign case study of an existing bracket. The optimal design is selected using multi-criteria decision analysis method. The challenges for using additive manufacturing technologies are discussed.

© 2015 The Authors. Published by Elsevier B.V. This is an open access article under the CC BY-NC-ND license

(<http://creativecommons.org/licenses/by-nc-nd/4.0/>).

Peer-review under responsibility of the scientific committee of the CIRP 25th Design Conference Innovative Product Creation

Keywords: Design for additive manufacturing; desing optimization; additive manufacturing; redesign

1. Introduction

The design process constantly balances the desire to remove material against the need to ensure that component stresses remain acceptable. Conventional manufacturing methods, such as turning and milling, impart limitations on the component geometries that can be produced. These limitations often result in structures that are inefficient, as many areas of a component have excess material that cannot be removed physically or cost effectively through conventional methods.

Additive Layer Manufacturing (ALM) techniques provide the opportunity to address the problem of inefficient structures. ALM enables components to be manufactured with material only where it is required. Components optimised to exploit the benefits provided by ALM can look very different from those designed to suit conventional production methods. It is challenging for engineers accustomed to designing components for conventional techniques to adapt their thinking to exploit the often organic shapes that ALM enables.

ALM technologies allow for the creation of intricate models and products comprise composite materials which can

be customised. ALM consists of methods, which develop 3D object in sequence adding layers over each other. There have been enhancements both in materials and in the methods themselves during the last three decades; nevertheless all methods are based on the layer-by-layer concept.

The aim of the present study is the development of a framework for redesigning existing components in order to exploit the benefits of ALM. This framework is tested and validated through the redesign of an existing component, currently designed to be manufactured using conventional techniques. The objectives set were to present a lightweight design and to develop a component design that remains rugged enough to survive the shock loads applied.

2. Literature review

ALM manufacturing technologies allow for the creation of models and products that are intricate in nature and made of composite materials which can be customised. ALM can be defined as the processes in which physical objects are made through layer by layer selective fusion, polymerisation or

sintering of materials. For every ALM process, the designers begin with 3D computer software and follow a number of general steps that are required to be undertaken for manufacturing a part (Fig. 1); these steps may vary with the technology used. Designers can take advantage of the processes capabilities in order to design complex designs by using unexplored regions of the design space.

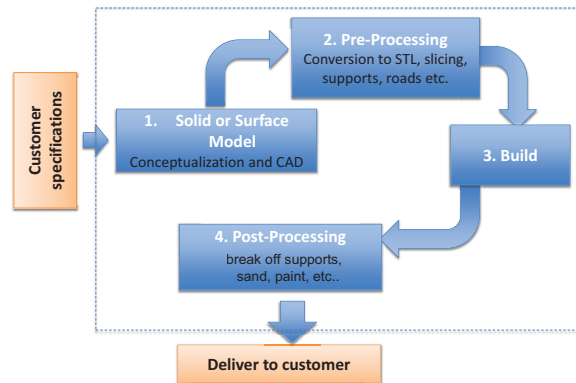

Fig. 1. ALM process steps for manufacturing.

ALM is stated to enhance design optimisation because of the designer's freedom and the fact that the design process is aided by a computer program, which allows layer by layer build-up of the model prototype [1]. Material complexity is another advantage, as ALM allows a wide range of materials to be used in the development of the product, which is not the case with traditional manufacturing.

Design methodologies that have been developed for manufacturing are attempting to constrain designer's imagination based on the manufacturing processes capabilities and limitations. For example limitations due to the use of tooling are no longer needed with ALM processes. A number of methodologies have been presented such as design for manufacturing and design for assembly with a number of variations for specific processes and industrial sectors.

Optimisation methods are also widely used for enhancing design; many different options exist such as multidisciplinary design optimisation (MDO), gradient methods, genetic algorithm optimisation (GA) to name few. Due to the high performance and affordable cost of computers, optimisation using commercial software is easy and reliable. Such software options present friendly interface, giving users the ability to identify variables of the design, constraints, objectives and optimisation results without performing any complicated algorithms or equations.

However, with regards the design frameworks for using ALM, there is a lack of studies. Only few have been published in the last five years. Some indicative studies include Rodrigue and Rivette [2] work on developing a design methodology based on design for assembly notion borrowing ideas from TRIZ analysis with regards the optimization of the alternative designs. Vayre et al. [3] presented a methodology composed of four steps for ALM of metallic components. Podshivalov et al. [4] documented a methodology for design tailored to medical applications. Ponche et al. [5] presented a

methodology for design based on numerical chain taking into consideration the part orientation during building, the functional optimization and the optimization of the manufacturing paths. Adam and Zimmer [6] documented a number of design rules for additive manufacturing that can be integrated in a design framework.

3. Redesign methodology

According to literature review, the research gap identified is the lack of a framework for re-designing existing products for better use of ALM capabilities. A redesign methodology has been developed in order to fulfil the research gap. Fig. 2 presents the proposed methodology for redesigning an existing part designed for conventional manufacturing into an optimised part designed for ALM. The key objective is to take into account the manufacturing constraints, objectives and ALM technology capabilities.

The proposed methodology has five main steps. The first step is analysing the specifications, based on the collection of information about the part in terms of functional specifications, loading requirements, manufacturing process limitations and capabilities, and material to be used in ALM. Within the second step rough shapes (initial concepts) are designed that fulfil the redesign objectives (e.g. maximum strength, minimal weight, stiffness). This step starts with finite element analysis (FEA), which allows the definition of the design problem in terms of the loads applied on the surface of the existing part and prediction of where the maximum deflection and stress will occur.

This step also includes structure optimisation through topology optimisation to achieve the optimal load path rather than a conceptual design. The third step defines a list of manufacturing restrictions that are necessary for deciding the manufacturability. In addition to guidelines for proper fabrication using the chosen ALM machine, such as the minimum slice thickness for each layer and speed of nozzle, process distinctive restrictions, such as the need for support structures and the anisotropic nature of the part strength, should also be considered.

The fourth step evaluates the proposed designs while taking into account all restrictions and guidelines already discussed. Verification and validation of the models may also be part of this step to ensure that the designs meet the load and displacements requirements. Moreover, all final designs that have fulfilled the requirements should be a part of a multi-criteria decision analysis with pre-defined attributes to choose the most suitable optimised design. Each step is detailed in the following sections.

3.1. Analysis of specification

Before the drafting of concepts, a set of functional specifications for the existing part must be agreed with clients. Usually defined by the client, functional specifications are factors that designs must follow relating to how the product will be used and how it will look. These specifications should be considered in the drawing idea stage to ensure that all factors are considered. The specifications can

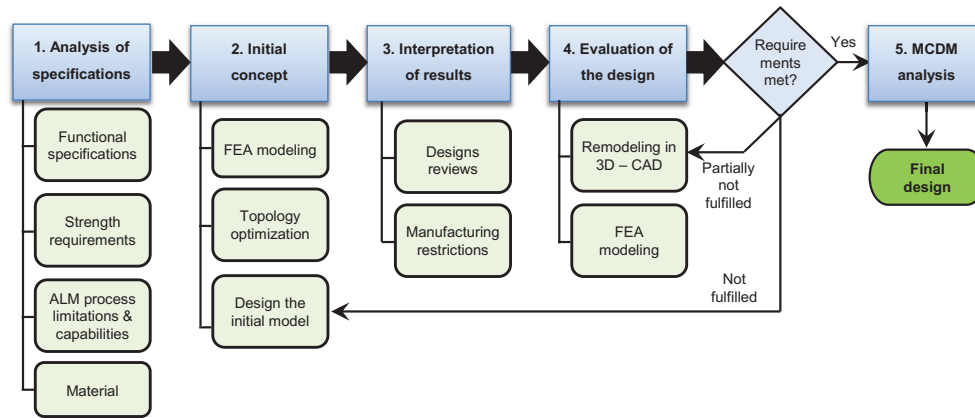

Fig. 2. Proposed methodology for redesign parts for ALM.

differ from one design to another. Requirements may include overall size, maximum weight, material, whether the part will be assembled with another part. In addition, the functional specification determines the surface quality of the product and the minimum durability. This step also considers the loads applied to the surface of the object.

ALM also allows for different shapes depending on how the machine deposits the layers to create the part. Selective laser melting (SLM), stereolithography (SLA), direct metal laser sintering (DMLS), fused deposition modelling (FDM) and selective laser sintering (SLS) are the most common processes available. The main considerations for determining which machine to be used are durability, speed and cost of both fabrication and material. ALM also offers a variety of materials, such as thermoplastics (ABS, PLA), aluminium alloys, titanium alloys, cobalt chrome alloys and papers. Considering both ALM processes and materials provides guidance for the structure of the model and how optimisation will be achieved.

3.2. Initial concept

Since ALM removes most of the limitations of conventional manufacturing, any complex design created by 3D CAD software can be directly transformed into the final product. Conventional manufacturing design constraints, such as avoidance of sharp corners, minimising weld lines, draft angles and constant wall thickness no longer need to be considered [7]. This allows designers to closely adhere to the initial design brief and specification.

FEA can be used for the prediction of stress distribution and deformations by simulating the existing model. Designers can use FEA to perform multiple analysis of the same design under different situations, such as boundary conditions, different materials and mixture of loads. After FEA yields the maximum stress and displacements, changes can be made if necessary. Topology optimisation is a systematic tool to produce a strong part with less waste of material. Topology optimisation builds an organic looking structure only where material is needed. There are several steps for topology optimisation [8]:

- Define the properties of the material, such as yield stress, Young's modulus, density, and poisson ratio.

- Apply single or multiple loads on the model and define where the support will be.
- Specify which region of the model will be optimised by topology and which region will not.
- Optimisation detail parameters such as the percentage of the material to be removed, convergence accuracy and minimum wall thickness.

3.3. Interpretations of results

This step allows the designers to consider and review the optimised model to determine if it can be built on ALM machines. Considering the capability and constraints of ALM, the designs that resulted from the last step may not be able to proceed directly to manufacturing. Major or minor modifications of the designs should be made to satisfy the capability of the chosen technology. Designers should address the specific constraints of the ALM machine. In general, the following constraints (design guidelines) can be applied for most ALM techniques:

- Avoid enclosed hollow volumes: Depending on the selected additive machine, any enclosed hollow volume will be filled with the support material during the building process. Therefore, these materials cannot be removed after the finishing process. This issue can be solved by adding a small hole to allow the support material to be removed. Another possible solution is to design in halves to avoid the enclosed hollow. It is also recommended to keep any open hollows in the part big enough to make it easier to clean and remove any chemical and support material later on.
- Choose proper clearances: Most ALM machines show standard tolerances beginning at $\pm 0.005''$ [9]. Proper clearance should be taken into account for mating assembly parts to avoid merging them together.
- Consider surface finish: The surface finish might be an issue in some ALM machines. Generally, parts manufactured using ALM will not have a smooth surface compared to the fine surface made by CNC-machines or moulding. Post-processes such as grinding and coating can be effective solutions to overcome the surface finish of parts made by ALM.

3.4. Evaluation of the design

Evaluation of the design allows designers to verify the performance aspects of the models. There are a variety of tools to help verify designs in term of performance of the material, model strength and fatigue tests. In the proposed framework FEA are suggested to be used for simulating the forces and loads applied to the part and shows how the part will react to these forces.

If some requirements are not met after verification, designers can make minor changes in the design and remodel it. However, if most of the requirements have not been met, then designers should start again from step 2 to build a new concept. Designs that fulfil all requirements proceed to multi-criteria decision analysis.

3.5. Multi-criteria decision making

The goal of this step is to help the designers choose the optimal design among the final concepts that have been validated. Multi-criteria decision analysis (MCDA) can assist in making this decision. MCDA is concerned with forming and solving decision and planning problems relating different criteria.

Different methods of MCDA can be applied to choose the best design. The graph theory and matrix approach (GTMA), analytic hierarchy process (AHP), and technique for order of preference by similarity to ideal solution (TOPSIS) are some methods used in MCDA.

The following processes are common to MCDA [10]:

- Identification of objectives: Clear objectives are very important to make appropriate decisions.
- Identification of criteria used to compare options: Once the objectives are well-defined, the next step is to decide how to compare options and contributions to meet the objectives. These criteria should be measurable to assess them and how each option will perform in relation to criterion.
- Decision making: The last step is to select the choice among the options.

Within the present study the AHP method is used.

4. Validation of the proposed framework

4.1. Case study

For the verification of the framework, a case study was selected for redesigning an existing part. The chosen bracket (Fig. 3) for this study was machined out of an aluminum alloy 6082-T6 block using CNC milling.

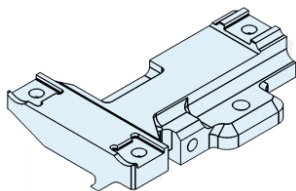

Fig. 3. Case study geometry for the verification of the proposed method

4.2. Analysis of specifications

The bracket is composed of three small recesses on the top surface that are used to position and secure the bracket using three screws. The redesigned bracket must provide the same recess features as in the original design. Moreover, the redesigned bracket must operate using the existing clamping components. It must be also compatible with the interfaces of the existing mounting rail in the bottom of the bracket. The bracket is subject to three orthogonal, non-concurrent shock loads equal to 1200 N.

The objective of the bracket redesign was to reduce the weight of the bracket by at least 20% of the original weight while maintaining the performance and preventing permanent deformation. Therefore, in order to be able to build it from an aluminium alloy (AlSi10Mg) an EOS Direct Metal Laser Sintering (DMLS) machine was selected.

4.3. Initial shape

In order to obtain several rough shapes of the bracket while adhering to the existing design brief and specifications, the following steps were followed:

- i. FEA was applied to the existing design of the bracket. Fig. 4(a) shows the FEA applied in the original design.
- ii. Topology optimization was used to find the optimal organic shape of the bracket. This method helps to determine where the material of the bracket is required and where it is in excess. The result is shown in fig. 4(b).
- iii. Considering both the result of the FEA of existing bracket and the optimised shape using topology, a wide range of models were designed. Creating many designs helps to explore and document concepts. Fig. 5 shows four of the rough shapes designed using the 3D CAD software.
- iv. FEA was used to simulate the shapes and determine whether they can bear the mechanical forces without failure. Fig. 6 shows the FEA results for some of these rough designs.

4.4. Interpretation of results

A set of restrictions were applied to the resulting designs from the previous step. The two main restrictions involved are manufacturing and geometry ones.

The EOSINT M280 was considered to fabricate the bracket using the Metal Laser Sintering (DMLS) technology. This technology allows features as small as 0.015" to be fabricated. The building envelope is 250x250x325mm and the achievable layer thickness is between 20 and 80 μm .

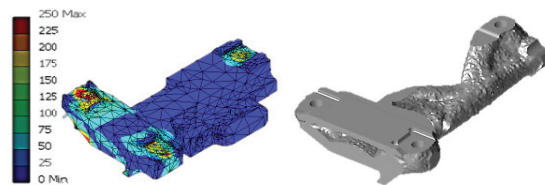

Fig. 4. (a) FEA applied to the original bracket design and (b) Optimised shape using topology optimisation

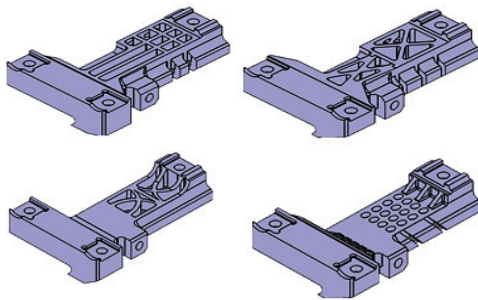

Fig. 5. Rough designs using 3D CAD software

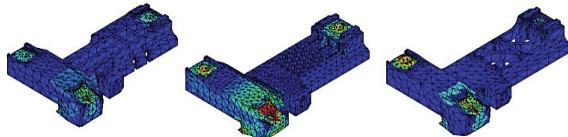

Fig. 6. Example of applying FEA to the initial rough designs

Additionally, the specifications of the selected material, EOS AlSi10Mg, were also considered. AlSi10Mg is an alloy used for products with thin walls and complex shapes. It exhibits good strength, toughness and dynamic properties; thus, it is often used in parts under high loads. Part accuracy is ca. $\pm 100 \mu\text{m}$, with wall thickness about 0.012 to 0.015" and 2.67 g/cm³ density.

The next step is to establish several shapes using 3D CAD software taking into account these constraints and the capabilities of the ALM machine as well as the materials without overlooking the optimized shape seen in Fig. 4(b).

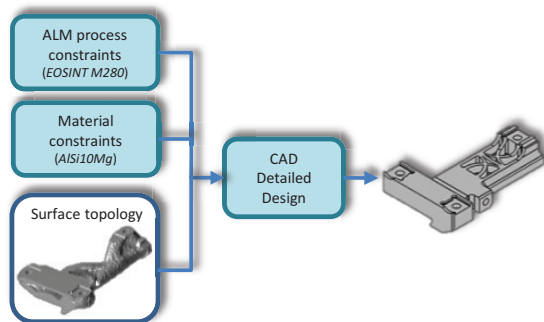

Fig. 7. Example of results interpretation

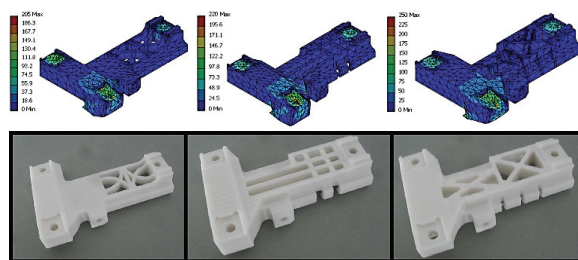

Fig. 8. (up) Verification using FEA and (down) fabricated models using FDM for design verification

Fig. 7 presents an example of a proposed geometry that follows the manufacturing and material constraints while taking the optimized shape into consideration.

4.5. Evaluation of the design

The last step of the proposed methodology is to verify the manufacturability of the designs and to determine if they can be built by ALM technologies. Verification was based on simulating each model using FEA. The results are shown in Fig. 8, indicating that maximum Von Mises stresses do not exceed the strength of the material. Design verification with physical prototypes was also achieved using FDM.

Based on the FEA analysis and the assessment of the physical prototypes, an initial shortlisting of the designs took place. For the case discussed, three designs met all requirements agreed including the functional requirement set by the client, the maximum Von Mises did not exceed the material strength, the manufacturing (EOSINT M280 machine) constraints were met and the designs did not have enclosures.

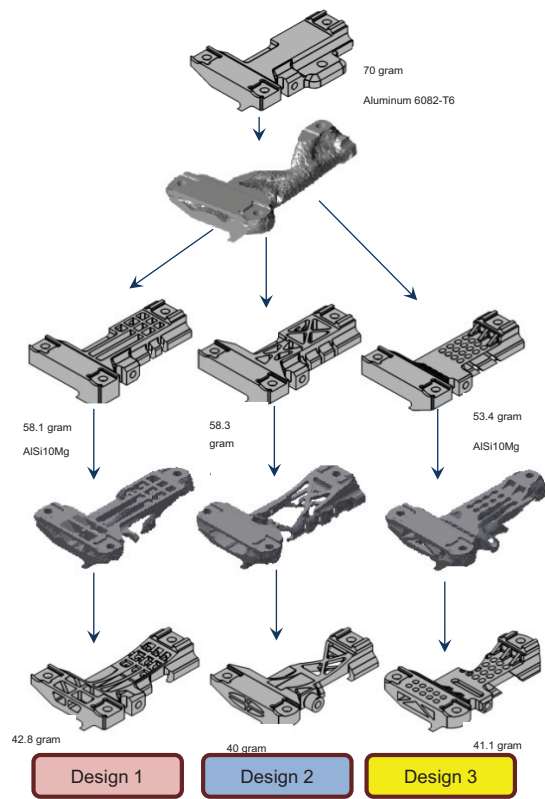

Fig.9. Roadmap optimisation of the three final designs

4.6. Multi-criteria decision making analysis

The designs chosen in the last step were compared using MCDA to choose one final design. The analytical hierarchy process (AHP) was used in this study to decompose the decision problem into a hierarchy of more easily

comprehended sub-problems. The AHP takes into account different parameters for many alternatives and gives the result that best matches these parameters.

The first step is to identify the objective, which is to find the best optimised design. The criteria used for comparison include, Light-weight, Strength, Minimum displacements, Manufacturing cost and Surface quality.

The three alternatives are shown in Fig. 9. AHP method for choosing the best optimised design is schematically presented in Fig. 10. The weighting of the criteria is based on client preferences. The weighting factors were calculated based on a pairwise comparison matrix. This analysis indicated that from customer’s point of view lightweight is the most important factor followed by strength. The weighted average pairwise comparisons between alternatives (Design 1, Design 2, and Design 3) with respect to each criterion (lightweight, strength, min displacement, cost, and surface quality) were reported in tables. The final weighted comparison is shown in Table 1. Fig. 11 graphically presents the results of the AHP analysis. Design 2 presents the most desirable characteristics, followed by Design 3 and Design 1. Manufacturing of Design 2 using EOS Aluminium alloy AlSi10Mg resulted in decreasing the original weight of the bracket from 70g to 40g, a 43% reduction.

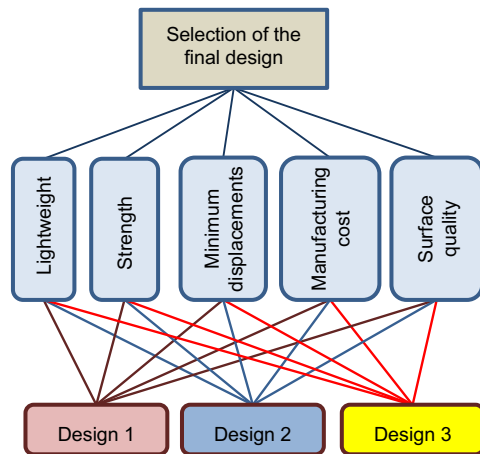

Fig.10. AHP hierarchy for choosing the optimized design

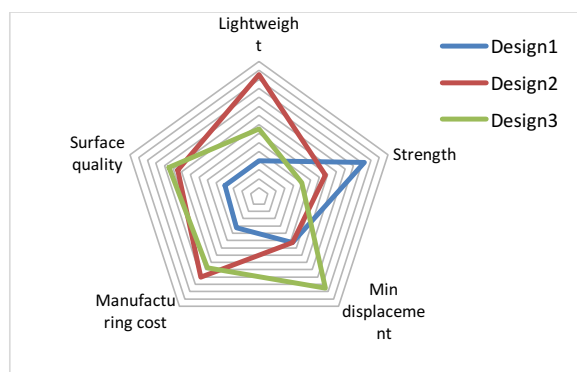

Fig.11. Multi-criteria decision making analysis results

Table 1. Final weighted comparison.

| | Light-weight | Strength | Min Displacement | Cost | Surface finish | Final Weight |
|-------------|--------------|----------|------------------|------|----------------|--------------|
| Rel. Weight | 0.37 | 0.30 | 0.13 | 0.18 | 0.03 | -- |
| Design 1 | 0.16 | 0.49 | 0.25 | 0.17 | 0.16 | 0.27 |
| Design 2 | 0.54 | 0.31 | 0.25 | 0.44 | 0.30 | 0.41 |
| Design 3 | 0.30 | 0.20 | 0.50 | 0.39 | 0.54 | 0.32 |

4. Conclusions

The major driver for this research was the fact that industrial designers do not have a clear methodology enabling them to review, redesign, and optimise existing designs in order to take full advantage of the benefits that ALM can offer. The proposed methodology addressing this challenge is characterised by several advances in how the redesigned and optimised models are approached. These advances are briefly:

- A new way of thinking by starting straight from the characteristics of the chosen ALM technology and the functional specifications of the component to design. Designers can find the geometry that optimises the use of the chosen ALM technology characteristics while meeting the functional specifications of the part.
- The use of topology optimisation to realise and optimised geometry of the model by removing all unstressed material from the part. Designers can compare the existing and the optimised design to find alternatives than can be manufactured by the chosen ALM process.
- MCDA analysis helps designers to choose one final design from the optimised designs. This analysis depends on pre-defined criteria than can be collected from the client.

References

- [1] Dym CL, Agogino O, Eriz DD Frey, Leifer LJ. Engineering design thinking, teaching and learning. Journal of Engineering Education 2005, 95/1:103-120
- [2] Rodrigue H, Rivette M. An assembly-level design for additive manufacturing methodology. Proceedings of IDMME – Virtual concept 2010, P20
- [3] Vayre B, Vignat F, Villeneuve F. Design for additive manufacturing. Procedia CIRP 2012, 3:632-637.
- [4] Podshivalov L, Gomes CM, Zocca A, Guenster J, Bar-Yoseph C, Fisher A. Design, analysis and additive manufacturing of porous structures for biocompatible micro-scale scaffolds. Procedia CIRP 2013, 5:247-252.
- [5] Ponche R, Kerbrat O, Mognol P, Hascoet J-Y. A novel methodology of design for additive manufacturing applied to additive laser manufacturing process. Robotics and Computer-Integrated Manufacturing 2014, 30:389-398
- [6] Adam GAO, Zimmer D. Desing for additive manufacturing – Element transitions and aggregated structured. CIRP Journal of Manufacturing Science and Technology 2014, 7:20-28.
- [7] Hague R, Mansour S, Saleh N. Design opportunities with rapid manufacturing. Assembly Automation 2013,23/4:346-356
- [8] Rozvany G. A critical review of established methods of structural topology optimization. Structural and Multidisciplinary Optimization 2009, 37/3:217-237
- [9] Gibson I, Rosen D, Stucker B. Additive manufacturing technologies. New York: Springer; 2010.
- [10] Wang J, Jing Y, Zhang C, Zhao J. Review on multi-criteria decision analysis aid in sustainable energy decision-making. Renewable and Sustainable Energy Reviews 2009, 13/9: 2263-2278.

2015-09-30

Redesign optimization for manufacturing using additive layer techniques

Salonitis, Konstantinos

Elsevier

Salonitis K, Al Zarban S, Redesign optimization for manufacturing using additive layer techniques, *Procedia CIRP*, Volume 36, 2015, Pages 193-198: CIRP 25th Design Conference Innovative Product Creation, 2-4 March 2015, Haifa, Israel
<http://dx.doi.org/10.1016/j.procir.2015.01.058>

Downloaded from Cranfield Library Services E-Repository