

Optimization of cut surface quality during CNC Plasma Arc Cutting process

Aristidis Tsiolikas¹, John Kechagias^{2*}, Konstantinos Salonitis³, and Nikos Mastorakis⁴

Abstract — Optimization of cut surface quality during CNC plasma-arc cutting (PAC) of mild steel plates is presented. Using design of experiments (DOE) the optimum process parameters are estimated. The process parameters tested include cutting speed, cutting height and arc voltage. Analysis of means (ANOM) and analysis of variances (ANOVA) were used in order for the effect of each parameter on the surface quality to be assessed.

Keywords — Plasma-arc cutting, Carbon steel plates, Design of Experiments, Surface Roughness.

I. INTRODUCTION

PLASMA-arc cutting (PAC) is a non-conventional manufacturing process used for the processing of a variety of electrical conducting materials (such as carbon steel, stainless-steel, aluminium, cast iron and non-ferrous metals) [1] (Fig. 1). PAC process (fig. 1) is characterized by an electric arc established between an electrode and the

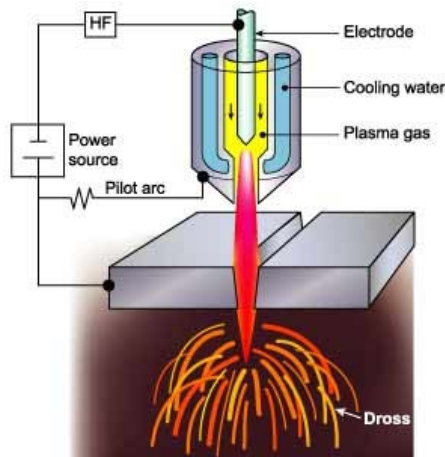

Fig. 1 The Plasma Arc Cutting Process [2]

¹A. Tsiolikas is with the Department of Mechanical Engineering, Technological Educational Institute of Thessaly, Larissa 41110, Greece (email: m5652@teilar.gr).

²J. Kechagias is with the Department of Mechanical Engineering, Technological Educational Institute of Thessaly, Larissa 41110, Greece (corresponding author: phone: 0030 2410684322, fax: 0030 2410684305, email: jkechag@teilar.gr).

³K. Salonitis is with the Manufacturing Department, Cranfield University, UK (e-mail: k.salonitis@cranfield.ac.uk)

⁴N. Mastorakis is with Department of Industrial Engineering, Technical University of Sofia, Sofia, Bulgaria (e-mail: mastor@tu-sofia.bg).

workpiece. The electrode acts as the cathode, and the workpiece material acts as the anode [3].

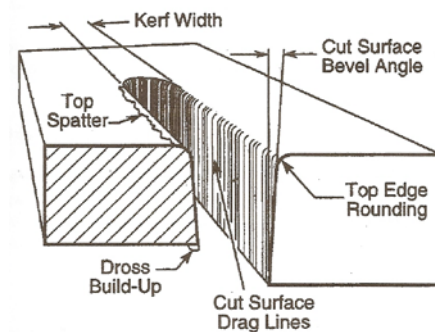

Fig. 2 Quality indicators of plasma-arc cutting [3]

Other thermal processes which are antagonistic with PAC are the laser beam machining process (LMP) and flame cutting. The selection of the most suitable of these processes for industrial applications depends on several factors such as type of material, layer thickness, cutting speed and quality indicators (Fig. 2) of each process as well as cost. PAC can be used in cutting of metal plates from approximately 5 to 40mm thickness [4].

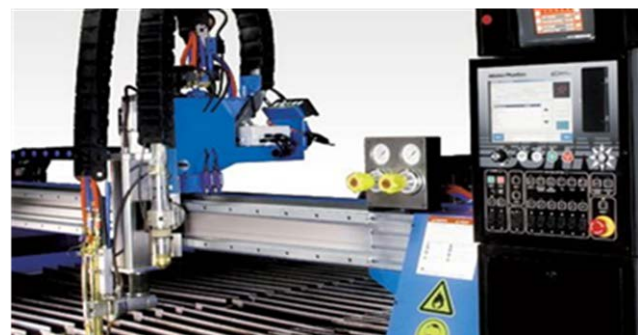

Fig. 3 Yildirim CNC PAC machine

Experimental multi-parameter optimization of the PAC process according to quality indicators such as kerf characteristics, dimensional accuracy and quality of cut surface have been studied by several researchers in several materials and experimental regions [3-11].

The current research work investigates the influence of plasma-arc cut process parameters on surface roughness of



Fig. 4 Experiment setup

St37 mild steel cut surface. A multi-parameter optimization was carried out using the full factorial design of experiments method.

II. EXPERIMENTAL SETUP

For the experiments, St37 carbon steel (mild steel), which is widely used for industrial applications, was used. The Yildirim CNC cutting machine was used having a Burny phantom MCU and HPR 260 air gas torch (Fig. 3). All experiments were performed 16mm thickness sheets (Fig. 4).

A three parameter design was performed. The full factorial design was used (Table 1). Columns A, B, and C, are assigned to cutting speed (mm/min), torch standoff distance (mm) and arc voltage (Volt), respectively.

A 30mmx40mm rectangular cut was performed for all 27 combinations as indicated in the orthogonal matrix experiment (Fig.4). The direction of the cut was clockwise (CW) for all experiments.

The surface texture parameter measured during this study was R_a (μm), and R_z (μm). For the sake of completeness the following definitions are provided.

- R_a is the arithmetical mean of the sums of all profile values. R_a is by far the most commonly used parameter in surface finish measurement and for general quality control. Despite its inherent limitations, it is easy to measure and offers a good overall description of the height characteristics of a surface profile.
- R_z is the mean of 5 maximum peak-to-valley roughness depths in 5 successive sampling lengths

The measurements were taken at the direction of the cut about 14 mm from the top surface of the part (Fig. 5). Mitutoyo Surftest RJ-210 tester (transverse length - 4.8mm) was used.

Table 1: Experimental array.

No	A. Cutting Speed (mm/min)	B. Torch Standoff Distance (mm)	C. Arc Voltage (Volts)	R_a (μm)	R_z (μm)
1	2000	3	145	1.673	12.1
2	2000	3	150	0.988	6.1
3	2000	3	155	0.756	6.0
4	2000	3.6	145	1.268	8.3
5	2000	3.6	150	0.899	6.3
6	2000	3.6	155	0.835	7.7
7	2000	4.2	145	1.231	6.8
8	2000	4.2	150	1.374	9.8
9	2000	4.2	155	0.860	6.3
10	2600	3	145	1.064	8.2
11	2600	3	150	3.795	27.5
12	2600	3	155	1.690	11.5
13	2600	3.6	145	1.058	7.3
14	2600	3.6	150	0.745	5.5
15	2600	3.6	155	1.088	7.1
16	2600	4.2	145	0.901	6.1
17	2600	4.2	150	0.641	5.4
18	2600	4.2	155	0.896	6.3
19	3200	3	145	0.921	7.3
20	3200	3	150	1.425	9.5
21	3200	3	155	1.014	6.1
22	3200	3.6	145	1.130	6.1
23	3200	3.6	150	1.325	8.1
24	3200	3.6	155	0.810	7.0
25	3200	4.2	145	1.0730	7.6
26	3200	4.2	150	10.839	67.6
27	3200	4.2	155	1.052	6.8
mean				1.532	10.4

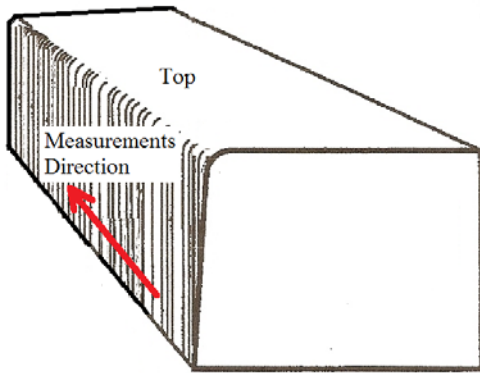

Fig. 5 Measurements Direction

III. ANOM ANALYSIS

After all the experiments were conducted and measured, analysis of means (ANOM) was performed onto the experimental results (Table 2 and 3) and relevant diagrams were exported (Fig. 6, and 7) in order to optimize the process according to the surface roughness performance of the process.

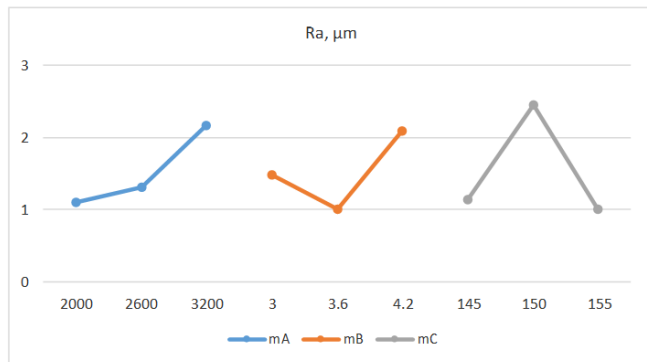

Fig. 6 Ra-Quality indicator of plasma-arc cutting

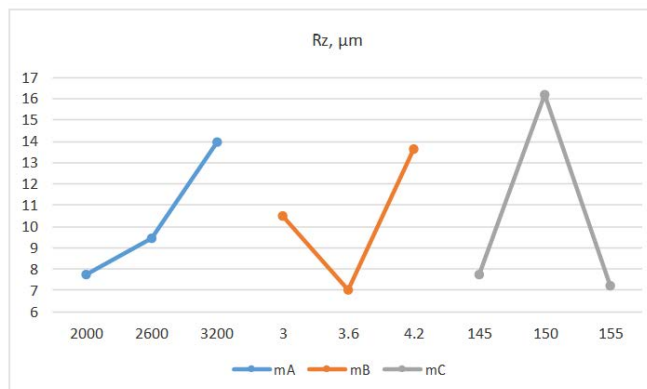

Fig. 7 Rz-Quality indicator of plasma-arc cutting

Table 2: Ra mean values for each process parameter level.

Means	Level 1	Level 2	Level 3
m _A	1.098	1.319	2.176
m _B	1.480	1.017	2.096
m _C	1.146	2.447	1.000

Table 3: Rz mean values for each process parameter level.

Means	Level 1	Level 2	Level 3
m _A	7.73	9.44	14.00
m _B	10.48	7.05	13.64
m _C	7.77	16.20	7.19

According to the ANOM analysis and diagrams, the optimum combination for optimizing both surface roughness quality indicators (Ra and Rz) is; Cutting Speed: 2000 mm/min, Torch standoff distance: 3.6 mm, and Arc Voltage: 155Volt.

IV. ANOVA ANALYSIS

Another way to assess the relative importance of the different parameters onto the performance indicators is by using the Analysis of Variances (ANOVA). ANOVA is also needed for estimating the error variances for the parameters effects and variances of the prediction error [11].

F is the variance ratio which is the ratio of the mean square due to a parameter and the error mean square (calculated in Tables 4 and 5). A parameter with an F ratio greater than 4 is considered as very important. On the other hand, if F ratio is smaller than 1, then it is considered as unimportant.

Finally, ANOVA analysis shows that the variance due to all parameters is about 22 percent of the total error. This indicates that the noise parameters of the process cause bigger variance, than the error caused due to the selected process parameters.

Table 4: Ra ANOVA analysis.

	DoF	SoS	MS	F	%
A	2	5.838	2.919	0.765	5.9
B	2	5.272	2.636	0.691	5.3
C	2	11.433	5.716	1.498	11.6
Total	6	22.543			22.8
Error	20	76.342	3.817		
Total Error (Σe _i)	26	98.884	3.803		

Table 5: Rz ANOVA analysis.

	DoF	SoS	MS	F	%
A	2	189.098	94.549	0.627	4.9
B	2	195.588	97.794	0.649	5.1
C	2	457.605	228.803	1.518	11.9
Total	6	842.291			21.8
Error	20	3013.744	150.687		
Total Error (Σe _i)	26	3856.035	148.309		

V. CONCLUSIONS

Analysis of means and analysis of variances show that all parameters affect about equal the surface roughness of the cut surface. The optimum levels of the process parameters that optimize surface roughness are: Cutting Speed 2000 mm/min, Torch standoff distance 3.6mm, and Arc Voltage 155Volt. The average surface roughness for this combination Ra is 0.835 μ m, and Rz is 7.7 μ m. Finally, ANOVA analysis shows that the noise factors cause bigger variance than that of the three process parameters accumulatively.

REFERENCES

- [1] S. Kalpakjian, *Manufacturing Engineering and Technology*, Addison-Wesley, 1995, pp.844-845.
- [2] S.M. Ilii , M. Coteata, A. Munteanu, "Experimental results concerning the variation of surface roughness parameter (Ra) at plasma arc cutting of a stainless steel workpiece", *International Journal of Modern Manufacturing Technologies*, II/1 (2010) 31-36.
- [3] K. Salonitis, S. Vatousianos, "Experimental Investigation of the Plasma Arc Cutting Process", *Procedia CIRP*, 3 (2012) 287 – 292
- [4] J. Kechagias, M. Billis, S. Maropoulos, "A parameter design of CNC plasma-arc cutting process using robust design", *Int. J. Experimental Design and Process Optimisation*, 2010, 1(4):315-326.
- [5] B. Asiabanpour, D.T. Vejjandla, J. Jimenez, C. Novoa, "Optimising the automated plasma cutting process by design of experiments", *Int. J. Rapid Manufacturing*, 2009, Vol. 1, No. 1, pp.19-40.
- [6] R. Bini, B.M. Colosimo, A.E. Kutlu, M. Monno, "Experimental study of the features of the kerf generated by a 200A high tolerance plasma arc cutting system", *Journal of Materials Processing Technology*, 2008, Vol.196, pp.345–355.
- [7] J.C. Chen, Y. Li, and R.I. Cox, "Taguchi-based Six Sigma approach to optimize plasma cutting process: an industrial case study", *International Journal of Advanced Manufacturing Technology*, 2009, Vol.41, pp.760–769.
- [8] E. Gariboldi, and B. Previtali, "High tolerance plasma arc cutting of commercially pure titanium", *Journal of Materials Processing Technology*, 2005, Vol.160, pp.77–89.
- [9] A. Gullu, and U. Atici, "Investigation of the effects of plasma arc parameters on the structure variation of AISI 304 and St 52 steels", *Materials & Design*, 2006 Vol.27, pp.1157–1162.
- [10] Q. Zhou, H. Li, F. Liu, S. Guo, W. Guo, and P. Xu, "Effects of nozzle length and process parameters on highly constricted oxygen plasma cutting arc", *Plasma Chemistry & Plasma Processing*, 2008, Vol.28, pp.729–747.
- [11] M.S. Phadke, *Quality Engineering using Robust Design*, Prentice-Hall, Englewood Cliffs, NJ, 1989.

Optimization of cut surface quality during CNC Plasma Arc Cutting process

Tsiolikas, Aristidis

2016-08-10

Attribution 4.0 International

Tsiolikas, A. et al. (2016) Optimization of cut surface quality during CNC Plasma Arc Cutting process, International Journal of Systems Applications, Engineering & Development, Volume 10, pp. 305-308

<http://www.naun.org/cms.action?id=12108>

Downloaded from CERES Research Repository, Cranfield University